

Tractor-Setting Type
Deep Aerator

TDA1200

BARONESS
Maintenance Machine

Owner's Handling Manual



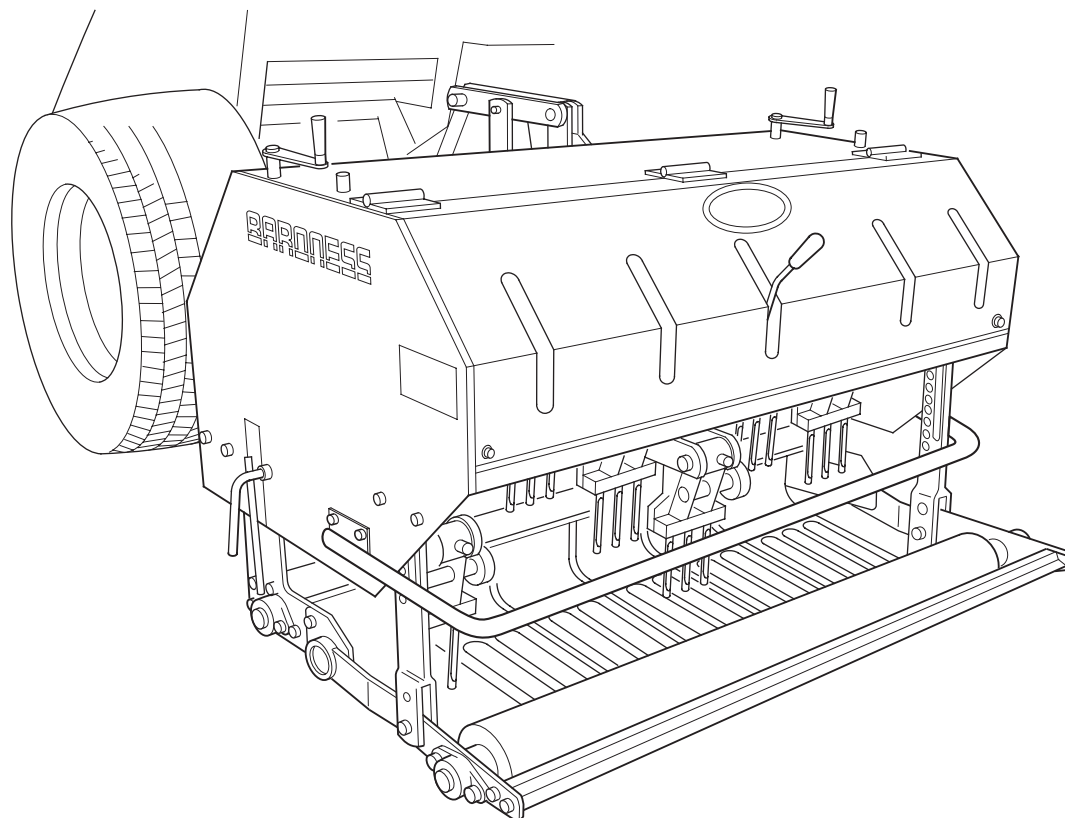



















2011.2~

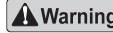

“Required reading” Before using the machine,
please read this manual and the operation manual of the tractor.

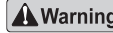
BARONESS[®]
Original Instructions

CONTENTS

CONTENTS	1	5.   Work procedure	13
Safety Warning	2	5-1.  Work procedure and operation	14
Introduction	2	5-2.  Other precautions as to work	14
   Precautions for Safe Work	3	6.  Transportation and transfer	15
Name of Each Part	6	7.   Replacement of each part	15
Location of Label	7	7-1. Tine	15
Features of TDA1200	8	7-2.   Bearing	15
Specifications	8	7-3. Location of machine number plate	15
Handling Instructions	9	7-4. Specification sheet for maintenance	15
1.  Attaching/detaching the maintenance machine	9	8. Long-term storage	16
1-1.    Attaching to the tractor	9	9. Maintenance schedule	16
1-2. Removing from the tractor	10	10. Timing chart	17
2.   Inspection and maintenance	10		
3. Tightening of each part	10		
4.  Appropriate adjustment for work	11		
4-1.   Adjustment of working depth	11		
4-2.  Adjustment of drilling pitch (traveling direction)	12		
4-3. How to use the rear roller	12		
4-4.  Changing the crank rotating speed	13		
4-5. [IMPORTANT] Greasing	13		

Safety Warning

Warning labels with  signs have been attached to this machine to ensure safe operation.

The warning labels indicate items that are particularly important from the point of view of safety, so please work safely and observe the warnings.

Warning labels



Neglect of the warning will result in death or serious injury.



Neglect of the warning will entail the risk of death or serious injury.



Neglect of the warning will result in injury or property damage.



...DANGER mark
(Tine)



...CAUTION mark
(Be careful of
being caught.)



...CAUTION mark
(Flying objects)



...CAUTION mark
(Be careful of
blades.)



...WARNING mark
(Be careful
of exhaust gas.)



...DANGER mark
(Rotating)



...CAUTION mark
(Rotating object)



...Refer to the Owner's
Handling Manual.



...CAUTION mark
(Rotating object)



...Greasing
50h

Introduction

Thank you very much for purchasing Baroness Maintenance Machine, TDA1200. This manual explains the method of correct use, adjustment, and maintenance of the machine. Thoroughly understand the contents of this manual before use of the machine.

Our machines have been tested and inspected sufficiently before shipment from the factory. However, it depends on the handling method, as well as daily inspection, adjustment, and lubrication before operation, whether the machine can display its original performance. Keep the machine well maintained to expect safe operation and the excellent performance for an extended period of time.

Please note

- The models may change sequentially.
When making an inquiry about this machine, please advise us of the model and serial number.
- The contents of this manual are subject to change without notice.

Caution ... About operation

- The warning labels used in this manual and stuck to the machine explain the method to ensure safety operation. Carefully read the operation procedure and safety precautions and thoroughly understand them before operation.
- Keep the labels and accompanying explanations clean, and replace them with new ones when they are lost or damaged. Never peel off the labels that is pasted on to the machine.

Precautions for Safe Work

This machine is equipped with tines (sharp bars) to drill holes in the lawn. Since the location of use, obstacles, and the condition of the lawn differ from place to place, as a manufacturer of the machine, we strongly urge the user, to inspect completely and maintain the machine, master the machine operation, and use the machine correctly in order to ensure the safety of the operator himself and other people, while keeping "safety first" in mind at all times.

Danger

• Thoroughly understand the correct operation procedure and precautions in order to ensure safety before operating the machine. Be sure to read the operation manual of the tractor before operating the tractor or attaching the machine to the tractor.



1) Clothes for safety

Warning

• Wear tight clothes for safety so that you will not get caught in the machine, and wear safety gear, goggles, shoes, helmet, and gloves appropriate for the work. An apron, towel wound around the waist, or long strings is likely to be caught in the machine, possibly causing you to be caught in the machine.



2) Emergency measures

Caution

• Understand the method to stop the engine in an emergency.

3) Do not operate the machine in such cases.

Warning

- Do not operate the machine when you are tired. If you get tired during machine operation, stop the work and take a rest.
- Do not allow any person who is sick, drunk, or under the influence of chemicals to operate the machine. The visual sense, alertness, and judgment are adversely affected.

- When you are unfamiliar with the machine operation, well understand the handling method and safety precautions in advance before use. Do not allow children to operate the machine.

4) When lending the machine to others

Caution

- When lending the machine, the borrower may cause an accident because of the lack of understanding about the safety precautions and handling procedure shown in the manual. Explain the handling method to the borrower. Lead the borrower to read the manual carefully before use.

5) Prohibition of remodeling of the machine

Caution

- Do not remodel the machine. Remodeling of the machine and use of parts other than those specified by our company can cause breakdown of the machine or life accidents.
- Use the parts, as well as oil and grease, specified by our company for replacement.

6) Prohibition of traveling and work at night time

Warning

- Do not operate the machine at night time or in bad weather when the visibility is poor.

7) Safety inspection before work

Danger

- Check up whether all covers are installed neatly at the specified locations and that there is no broken part.
- Check up whether bolts and nuts loosened. If they are loose, tighten them completely.
- Check up whether the brake, levers, and tires work normal.

8) Precautions to take during work



- This machine is designed for maintenance of the putting green. It is very likely to overturn on a slope. Do not use the machine on a slope.
- Do not operate the machine in places in danger of a land subsidence or landslide.
- The machine may overturn on a slope with an irregular surface. Do not operate the machine in such a place.
- The machine is in danger of slipping and overturning on a wet slope. Do not operate the machine in such a condition.
- When the machine is attached to the tractor the total length will increase. Be careful of the people and objects around the machine when turning the tractor. Do not back or turn the tractor when the machine is in the lower position ready for work.
- Do not touch the tines, crank, and other moving sections when the machine is in operation, otherwise your fingers or hands may get injured.
- Check the surroundings for safety (front, back, right, and left, as well as trees, ditches, irregular surface of the green, sprinklers, and cups etc.) during operation. Operate the machine at an appropriate speed so that you can stop the machine any time in an emergency. Avoid sudden acceleration, sudden braking, and abrupt steering. Drive the machine slowly especially when descending a slope.
- Check to see if someone is playing in the vicinity. There is a danger of getting struck with a hit ball.
- This machine is not a riding type. Attach the machine to the three-point hitch of a tractor, and raise the machine to carry it to the work place. Carefully operate the tractor. Be sure to avoid inattentive driving and driving the tractor without holding the steering wheel.
- Never tow the machine on public roads.



- When abnormal vibration, abnormal sound (wire or vinyl coiling around the tines), or other anomaly occurs in the machine during work, stop the engine immediately and investigate the cause. Completely repair the machine before operating it again.
- When stone or rock is expected to exist under the ground, lower the speed of PTO rotation.
- Remove stone, wire, sticks, and other obstacles before work, otherwise not only machine trouble but also an accident due to the scattering of such objects may result.
- When leaving the machine, park the machine on a flat ground, stop the engine, remove the key, put on the park brake, and put a chock block under the tire. Lower the machine to the ground.
- Lower the machine slowly so that the lawn and machine will not be damaged.
- When colliding with some obstacle, stop the engine and check each part for damage.
- Do not lower the machine and move forward without turning the PTO shaft, otherwise the lawn and machine will be damaged heavily.
- Do not move backward when the machine has lowered and touched on the ground, otherwise the lawn and machine will be damaged heavily.

9) Precautions as to inspection and maintenance

- Thoroughly understand the method of maintenance and inspection.
- Do not feed oil, maintain, or inspect the machine when it is in operation.
- Do not bring your hands or feet near the driving and operating sections.
- Attach all parts in a good condition.
- Repair or replace damaged parts immediately.
- Replace worn or damaged parts with new ones.
- Do not remodel the machine. Use genuine parts to ensure safety.
- Remove dust, grease, and oil adhering to the machine.



Warning

- Maintain and inspect the machine after parking it on a clean, dry, flat ground where the machine is not in danger of overturning or where there is no risk of traffic danger. Put a chock block under the front wheel of the tractor.
- When inspecting, maintaining, repairing, or cleaning the machine while it is being attached to the tractor, be sure to put on the parking brake of the tractor and stop the engine. Set the PTO speed change lever in the “NEUTRAL” position and wait until all the rotating parts stops before work. Do not run the engine indoors or in poorly ventilated place. The exhaust gas contains hazardous carbon monoxide.



- Do not enter or put your foot in the space under the machine.
- When holding tines for attaching or detaching, wear thick gloves.
- Check up whether all covers are installed neatly in the specified places and that they are not broken.
- When the tines are loose or damaged, they will be broken and scattered around. Check up whether they are not loose before work. If they are loose, tighten them completely.
- When disassembling the machine to replace the bearing, exercise care so that your fingers or hand will not be caught in the parts.



Caution

- Completely close the hydraulic stop valve to prevent the machine from falling. Be sure to put wooden blocks or other supporting tools under the frame for safe operation.
- Check up whether bolts and nuts loosened. If they are loose, tighten them completely.
- Keep the labels and accompanying explanations clean, and replace them with new ones when they are lost or damaged.
- When storing the machine alone, secure it on a flat ground.



10) Attaching/detaching the machine to/from the tractor

Warning

- Attach and detach the machine on a flat stable ground.
- When moving the tractor to attach/detach the machine, exercise care so that no one is around the tractor or at a location between the tractor and machine.
- Stop the engine of the tractor to ensure safety before work.
- Do not enter or put your foot in the space under the machine.
- Attach five balance weights to the front of the tractor. The absence or insufficiency of weights will cause the machine to lose balance, and the machine will overturn.

Caution

- Do not raise the machine when the lower link of the tractor has been attached on one side only.
- Do not keep rotating the drive shaft while the machine has been raised, otherwise the drive shaft and machine may break.
- When raising the machine after attaching it to the tractor, check that the upper link (top link) and lower link have been attached completely.

11) Storage

- Let the transmission section and rotating parts of the machine cool before covering the machine with a sheet.

Name of Each Part

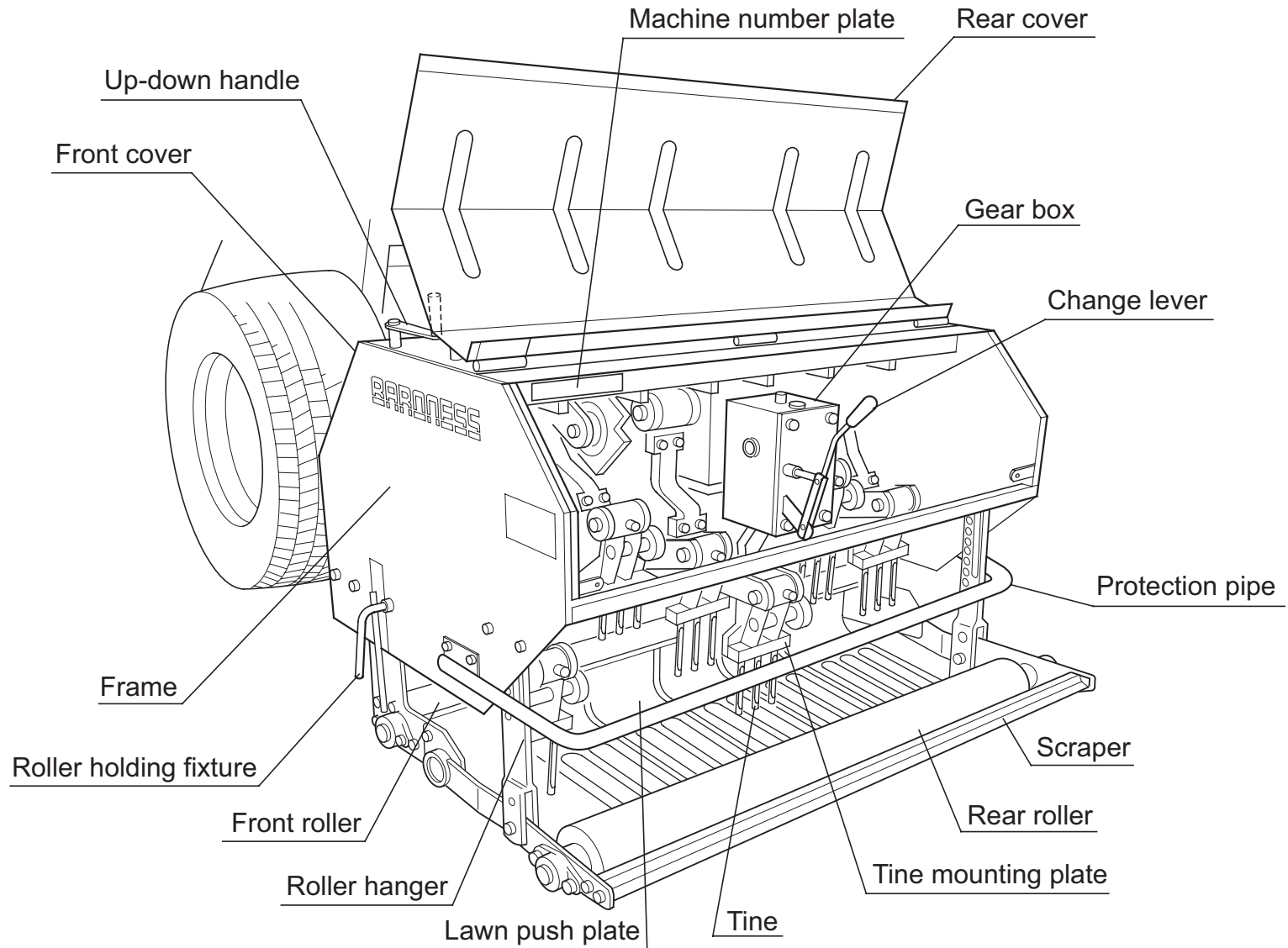

Location of Label

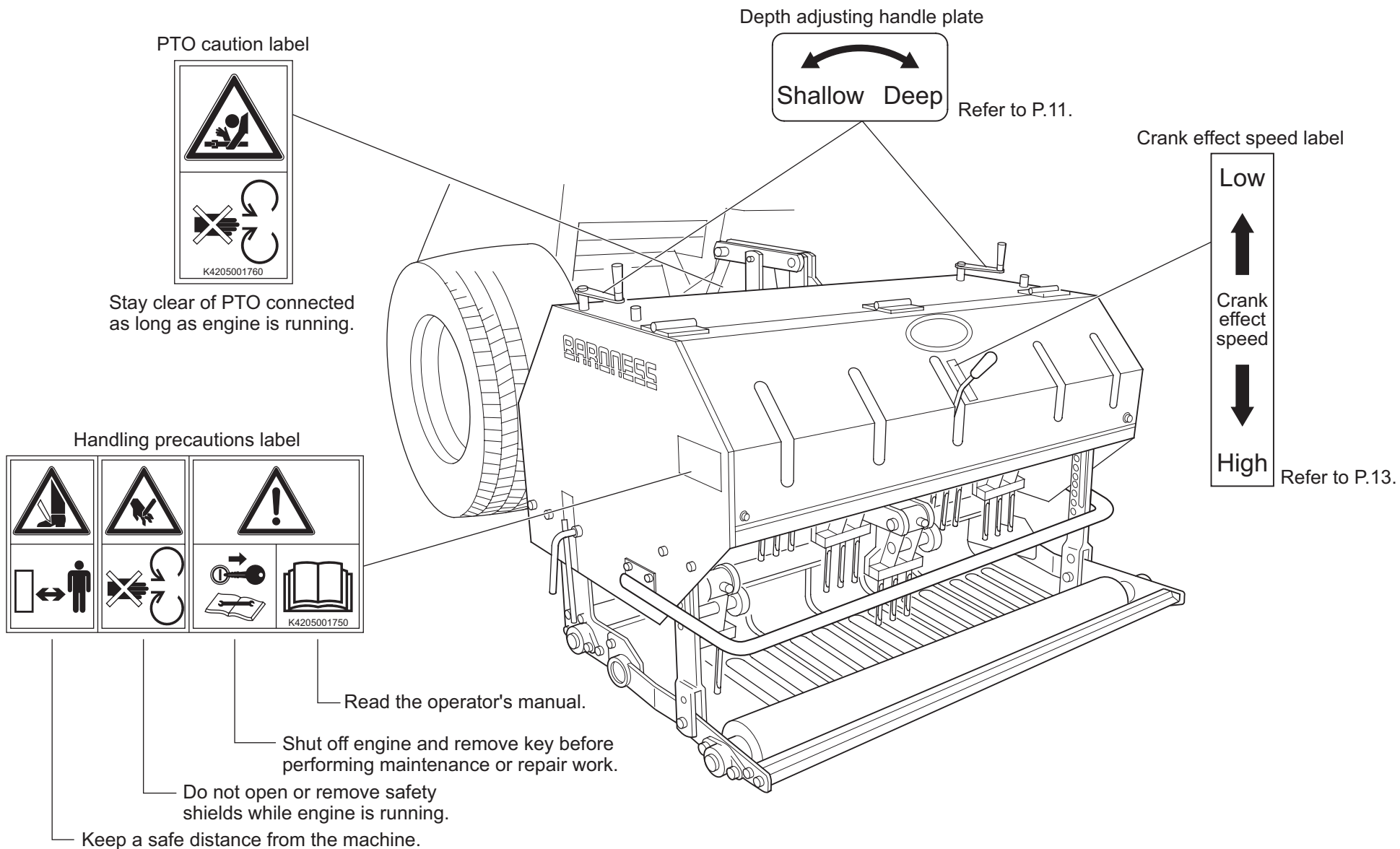

Features of TDA1200

- The maximum coring depth is 250 mm.
- The depth can be adjusted by turning the up-down handle without using any tool.
- The machine is equipped with a two-stage speed changer. Speed change with a lever permits easy change of the working speed.
- Use of the various optional tine-mounting holders permit attachment of desired tines according to the nature of work.

Specifications

Machine	Total length	97cm
	Total width	142cm
	Total height	85cm
	Total weight	495kg
Applicable tractor	13.2 kW (18 PS) or more	
Driving method	PTO driving	
Transportation	Tractor ; 3-point link lifting type	
Number of tines	18 pcs (Various options available)	
Working width	117cm	
Pitch (Traveling direction)	Refer to "Table: Relationship between working speed and pitch."	
Interval	6.5•10cm	
Working depth	Max. 25 cm (depending on the condition)	
Working speed	Refer to "Table: Relationship between working speed and pitch."	
Transmission	Slow/high speed one-touch change lever	
Speed of PTO rotation	Max. 400 rpm	
Efficiency	1,872 m ² /h (at 1.6km/h)	

Table: Relationship between working speed and pitch

Tractor EF222S; engine speed ... 1,800 rpm

Auxiliary speed change	Main speed change	Speed	PTO rotation	Crank rotation	Pitch (mm)
1	1	0.52km/h	1st speed	Slow speed	53mm
				High speed	42mm
1	2	0.75km/h	1st speed	Slow speed	75mm
				High speed	60mm
1	3	1.06km/h	1st speed	Slow speed	108mm
				High speed	86mm
1	4	1.60km/h	1st speed	Slow speed	163mm
				High speed	130mm

Caution



- The engine speed is 1,600-2,000 rpm during tractor operation. The maximum PTO rotation speed is 400 rpm. Be sure to understand the operation manual of the tractor.

Handling Instructions

1. Attaching/detaching the maintenance machine



- Attach and detach the machine on a flat compacted ground.
- When moving the tractor in order to attach/detach the machine, exercise care so that no one is around the tractor or at a location between the tractor and machine. Stop the engine of the tractor to ensure safety before work.
- Do not enter or put your foot in the space under the machine.



1-1 Attaching to the tractor

1) Attaching the balance weight



- Attach five balance weights to the front of the tractor. The absence or insufficiency of weights will cause the machine to lose balance, and the machine will overturn.
- Add balance weights as necessary when operating the machine on the ground with many slopes.

2) Attaching the machine to the 3-point link of the tractor



- Respective parts of the machine are very heavy. Two or more workers should carefully handle the machine.



- ① Lower the 3-point link of the tractor to the lowest position, and stop the engine. Check that the parking brake of the tractor has been applied and chock blocks are put under the tires.
- ② Attach the machine to the right and left lower links of the tractor with “22 hardened flat head pin 145 (1-21).”

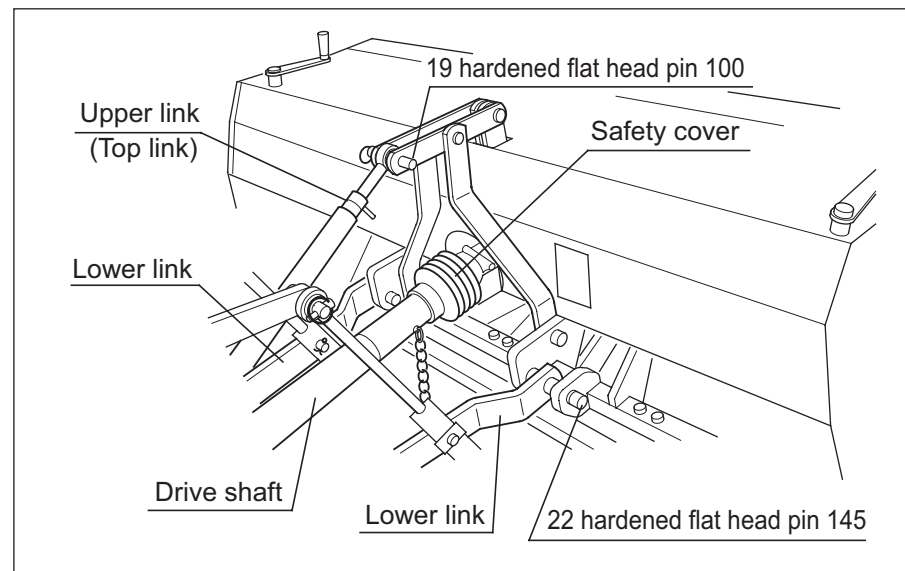

- ③ Attach the upper link (top link) of the tractor to the machine with “19 flat head pin 100 (1-3),” and adjust the upper link so that the machine will be almost horizontal.

[IMPORTANT]

Adjust the deflection of the right and left lower links of the 3-point link of the tractor.

④ Attaching the drive shaft

- Attach the “drive shaft (3-39)” to the PTO of the tractor and the transmission “drive shaft A (3-34)” on the machine side. Check that the lock pins of the “drive shaft” are set in the groove in the respective shafts.
- Attach the whirl-stop chain of the safety cover to the hook of the lower link.

[IMPORTANT]

Be sure to attach the clutch of the drive shaft to the tractor side.

- ⑤ Make sure there is no one near the machine, start the tractor engine, and then raise the attached machine slightly.

Danger

- Be sure to stop the tractor engine before making adjustment.

[IMPORTANT]

If the sliding section of the “drive shaft (3-39)” is too long when the machine is raised, cut it to an appropriate length.

- ⑥ Make sure the tines is not attached to the machine, lower the machine (so that the front roller will be in contact with the ground), rotate the PTO shaft, and confirm that the drive shaft and machine are not generating abnormal vibration or sound. If there is any abnormal vibration or sound , adjust the mounting location of each link etc.

[IMPORTANT]

- Do not raise the machine when the lower link of the tractor is attached on one side only.
- Do not keep rotating the drive shaft while the machine is raised, otherwise the drive shaft and machine may break.

1-2 Removing from the tractor

Reverse the procedure of [1-1](#) Attaching to the tractor.

2. Inspection and maintenance

Warning



- Completely tighten the hydraulic stop valve to prevent the machine from falling. Put wooden blocks or appropriate substitutes under the frame for safe operation.
- Do not enter or put your foot in the space under the machine.
- Park the tractor on the flat stable ground where the tractor will not be in danger of overturning or moving and where there is no risk of traffic danger. Put a chock block under the front wheel of the tractor.
- When inspecting, maintaining, repairing, or cleaning the machine while it is being attached to the tractor, be sure to put on the parking brake of the tractor and stop the engine. Set the PTO speed change lever in the “NEUTRAL” position and wait until all the rotating parts stops before work. Do not run the engine indoors or in poorly ventilated place. The exhaust gas contains hazardous carbon monoxide.



- 1) Check the following locations and take corrective measures immediately when nonconformance is found.

Warning



- Check up whether all covers are installed neatly in the specified places and they are not broken or missing.
- When holding tines to attach or detach them, wear thick gloves.

Caution

- Check up whether respective tines are attached correctly and mounting bolts are not loose. When tines are loose or damaged, they will be broken and scattered around. If they are loose, tighten them completely.
- Keep the labels and accompanying explanations clean, and replace them with new ones when they are lost or damaged.
- Check up whether bolts and nuts loosened. If they are loose, tighten them completely.

- ① Check up the condition of installation of the drive shaft (PTO shaft on the tractor side and drive shaft A on the machine side).
- ② Check up the quantity of the gearbox oil.
- ③ Be sure to clean the machine after work. When using a washer, the water pressure should be low and the water temperature should not exceed 60°C.
- ④ Check up whether tines dont crack and warp.

3. Tightening of each part

Many bolts are used in this machine. Bots and nuts may get loose for some time after initial use. Inspect respective pants and tighten them correctly.

Appropriate tightening torque N•m (kgf•cm)

	Ordinary bolt	Hardened bolt
M8	18(180)	36(360)
M10	36(360)	72(720)
M12	60(600)	120(1200)
M14	90(900)	180(1800)
M16		260(2600)
M20		370(3700)

4. Appropriate adjustment for work

Warning

- Check that the front roller is in contact with the ground before work. When coring too deep at once, the roller may be lifted according to the condition of the soil, possibly breaking the PTO of the tractor or the machine.
- Large tines and attachments may cause the tine holder to be lifted. Slow down the PTO speed or stop the machine before the tine holder overturns.
- When the machine is vibrating, the vibration may damage the lawn, tractor, or machine. Check the attaching condition of the machine and tine holder, and make adjustment to remove the vibration.
- Be sure to stop the rotation of the PTO of the tractor before changing the rotating speed of the crank of the machine.

4-1 Adjustment of working depth

Danger • Be sure to stop the tractor engine before adjustment.

Turn the up-down handle to adjust the working depth.

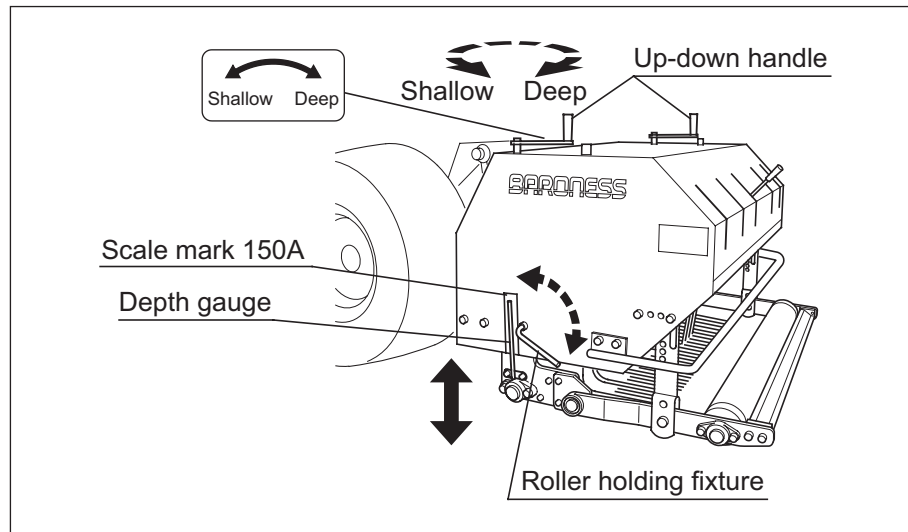

Warning

- When moving the front roller up and down, move the right and left up-down handles two turns alternately. When one side alone is moved up and down, the scraper and lawn push plate will be deformed.

[Adjustment of tine depth]

- ① Loosen the right and left “roller holding fixtures (2-4).”
- ② Turn the right and left “up-down handles (2-38)” to adjust the working depth. (Approx. 4 mm/turn)
 - Turn the up-down handle clockwise to increase the coring depth. (The roller rises and the machine lowers.)
 - Turn the up-down handle counter clockwise to decrease the coring depth. (The roller lowers and the machine rises.)
 - A depth gauge and scale mark 150A are provided on both sides of the machine. One scale corresponds to 1cm. When the tip of the depth gauge is at the uppermost edge of the scale, it shows the maximum depth of standard tine.
- ③ Tighten the right and left “roller holding fixtures.”

[IMPORTANT]

The scale does not indicate the actual depth. It is just a rough indication. Judge the depth by actual work.

Danger

- Do not adjust the coring depth during operation. It is very dangerous.
- Select an appropriate coring depth in consideration of the working condition. Work without taking the working condition into consideration may apply excessive force to the machine, possibly damaging the tines and machine. Pay special attention to the transmission parts of the machine. When working depth is deeper, slow down the working speed as necessary.

4-2 Adjustment of coring pitch (traveling direction)

- The coring pitch changes according to working speed and the position of the change lever. Refer to the table below.

Table: Relationship between working speed and pitch

Tractor EF222S; engine speed ... 1,800 rpm

Auxiliary speed change	Main speed change	Speed	PTO rotation	Crank rotation	Pitch (mm)
1	1	0.52km/h	1st speed	Slow speed	53mm
				High speed	42mm
1	2	0.75km/h	1st speed	Slow speed	75mm
				High speed	60mm
1	3	1.06km/h	1st speed	Slow speed	108mm
				High speed	86mm
1	4	1.60km/h	1st speed	Slow speed	163mm
				High speed	130mm

Caution



- The engine speed is 1,600-2,000 rpm during tractor operation. The maximum PTO rotation speed is 400 rpm. Be sure to understand the operation manual of the tractor.

4-3 How to use the rear roller

- If the rear roller is equipped, when using spike tines for coring, it functions to trample the lawn surface, so golfers will be possible to play immediately.
- When using side open tines for coring, keep the rear roller raised, to avoid to trample the grass and soil removed by the side open tines.

When using the rear roller

- Remove the "12 hardened flat head pin 40 (2-1)" that is securing the rear roller.
- Insert the "12 hardened flat head pin 40" into the hole adjacent to the roller holding plate to prevent it from being lost, and insert the "10KS snap pin (2-10)."
- The rear roller will be released. Do the same operation on the opposite side.

When not using the rear roller

- Disconnect the "10KS snap pin" of the "12 hardened flat head pin 40," and remove the "12 hardened flat head pin 40."
- Raise the roller hanger and insert the "12 hardened flat head pin 40." Then insert the "10KS snap pin."
- Raise the opposite side in the same way.
- Secure the rear roller at a certain height so that it will not trample the grass and soil removed by side open tines.
- Secure the opposite side in the same way.

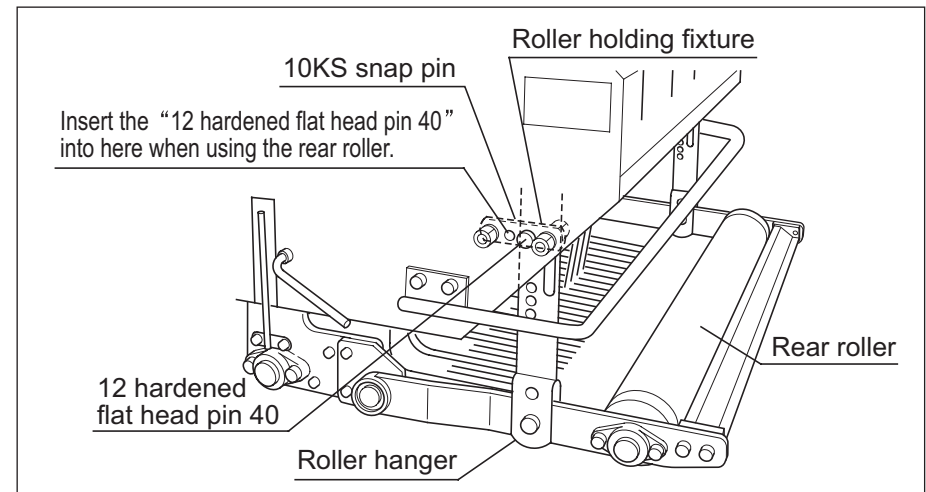

4-4 Changing the crank rotating speed

- Operate the “change lever (3-2)” for switching over crank rotation speed to change high and low speed.

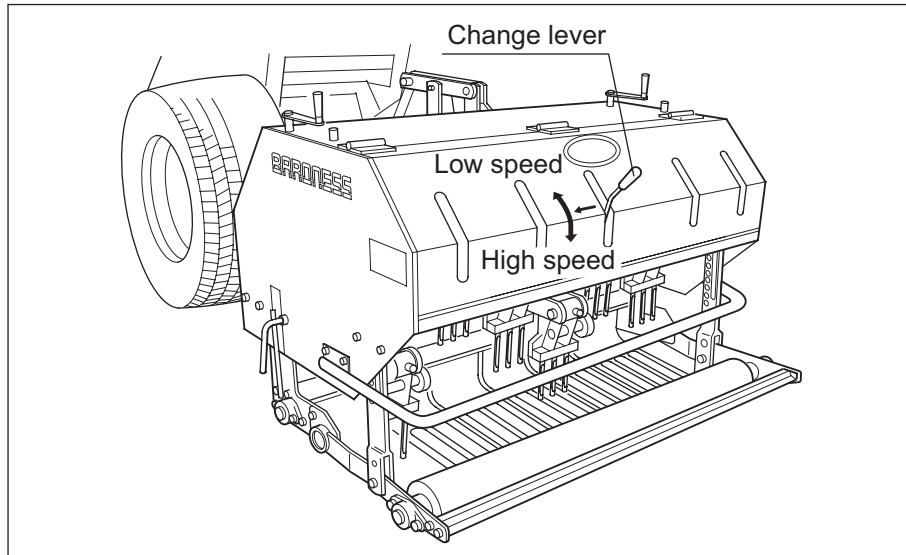

- Caution**
- Stop the PTO rotation before switching over the speed.
 - When the “change lever” for switching cannot be engaged easily, step on the catch pedal of the tractor once again, then the change lever will be engaged easily. If you operate the change lever forcibly, the transmission and change lever can be damaged.

4-5 [IMPORTANT] Greasing



Periodically fill up the respective grease nipples with approx.1 mg (1-2 times operation with a compact manual grease pump) of grease (Xcelite EPNO2).

5. Work procedure

- Warning**
- Do not operate the machine in places in danger of a land subsidence or landslide.
 - The machine may overturn on a slope with an irregular surface. Do operate use the machine in such a place.
 - Avoid operation on slopes.
 - The machine is in danger of slipping and overturning on a wet slope. Do not operate the machine in such a condition.
 - Check to see if someone is playing in the vicinity. There is a danger of getting struck with a hit ball.
 - Check the surroundings for safety (front, back, right, and left, as well as trees, ditches, irregular surface of the green, sprinklers, and cups etc.) during operation. Operate the machine at an appropriate speed so that you can stop the machine any time in an emergency. Avoid sudden acceleration, sudden braking, and abrupt steering. Drive the machine slowly especially when descending a slope.
 - When the machine is attached, the total length will increase. Be careful of the people and objects around the machine when turning the machine. Do not back or turn the machine when the machine is in the lower position ready for work.
 - Do not touch the tines, crank, and other moving sections when the machine is in operation, otherwise your fingers or hands may get injured.
 - Do not operate the machine at night time or in bad weather when the visibility is poor.



- Caution**
- Do not move forward when lowering the machine and without turning the PTO shaft, otherwise the lawn and machine will be damaged heavily.
 - Lower the machine slowly so that the lawn and machine will not be damaged.
 - Do not move backward when the machine has lowered and touched on the ground, otherwise the lawn and machine will be damaged heavily.

- When stone or rock is expected to exist under the ground, lower the speed of PTO rotation.
- When abnormal vibration, abnormal sound (wire or vinyl coiling tangled in the tines), or other anomaly occurs in the machine during work, stop the engine immediately and investigate into the cause. Completely repair the machine before operating it again.
- When colliding with some obstacle, stop the engine and check up whether respective parts are not damaged.
- Remove stone, wire, sticks, and other obstacles before work, otherwise not only machine trouble but also an accident due to the scattering of such objects may result.
- When leaving the machine, park the machine on a flat ground, stop the engine, remove the key, put on the brake, and put a chock block under the tire. Lower the machine to put it on the ground.



5-1 Work procedure and operation

The following procedure presupposes that the machine has been attached, the coring depth has been adjusted, and the crank rotation speed has been switched over properly.

⚠ Danger

- Select an appropriate coring depth in consideration of the working condition. Work without taking the working condition into consideration may apply excessive force to the machine, possibly damaging the tines and machine. Pay special attention to the transmission parts of the machine. When coring depth gets deeper, slow down the working speed as necessary.
 - Be sure to stop the tractor engine, apply the parking brake, and put chock blocks under the wheels, than remove the tines from the machine, and then lower the machine onto the ground before adjustment and maintenance.
- ① Transfer the machine with raising position to the location in front of the working point. Select an appropriate speed so that the machine will not vibrate. Although it depends on the topography, drive the tractor at a slow speed because the machine is wide.
 - ② Select the crank rotation speed using the change lever.

- ③ Select an appropriate working speed by combining the main transmission and auxiliary transmission of the tractor. (Refer to **4-2** "Table: Relationship between working speed and pitch.")
- ④ Lower the machine slowly.
- ⑤ Raise the engine speed up to the preset PTO rotation speed.
- ⑥ Move the machine back and forth during work.
 - Keep the front roller in contact with the ground at all times during work. If the machine becomes unstable, change the PTO rotation speed to stabilize the machine. If it does not stabilize, change the coring depth, change the size of tines, or change the tines with new ones.
- ⑦ When the work is finished, stop the tractor, operate the tractor up-down lever to raise the machine.
- ⑧ When all tines get off the ground, stop the PTO rotation immediately.
- ⑨ Move to the next work place, and continue the work following the above procedure.

5-2 Other precautions as to work

⚠ Caution

- Check that the front roller is in contact with the ground before work. When the coring depth is too deep, the roller may be lifted according to the condition of the soil, it possibly cause to damage the PTO of the tractor or the machine.
- Large tines or attachments may cause the tine holder to be lifted. Slow down the PTO speed or stop the machine before the tine holder overturns.
- Do not rotate the drive shaft at an angle exceeding 30 degrees.
- Carefully select the coring depth according to the condition of the putting green. If the coring surface is too hard it will apply excessive force to the driving system of the machine, causing breakage. Decrease the coring depth in such a condition.
- Excessively high PTO rotation speed (more than 400 rpm) will apply excessive force to the machine, causing breakage of the machine or spouting of oil from the gearbox.
- High-speed operation will lower the work effectiveness. Select an appropriate working speed according to the condition.
- Meandering operation is likely to damage the putting green. Move the machine straight.
- Do not turn the PTO in the reverse direction, otherwise the machine can be broken.

6. Transportation and transfer

⚠ Danger

- Traveling at a maximum speed is likely to cause bounce and jounce, damaging the machine.
- Load the machine on a truck for transportation.
- Never drive a tractor equipped with the machine on public roads.
- When the machine is attached to a tractor for transportation, drive the tractor so that the traveling speed will not exceed 10 km/h, which depends on the geographical features. When moving up and down on a slope, exercise special care to drive the tractor at a speed that will permit emergency stop at any time.
- When you feel that the front of the tractor is lifted on a slope, it is very likely that the steering wheel will not function or the tractor may be overturned. Be sure to add some balance weights in that case.

7. Replacement of each part

⚠ Danger

- Rotating tines and cranks are dangerous. Be sure to stop the tractor engine unless it is necessary to raise or lower the machine.



⚠ Caution

- Tines are dangerous. Wear thick gloves when handling them.
- Replace all tines with new ones at a time. Mixed use of old and new tines will cause abnormal vibration.
- Use genuine tines to ensure safety.



7-1 Tine

- ① Loosen the “10 stainless steel hexagon socket head special bolt 30” (4-55) that is securing the tine to the tine mounting plate, and remove the tines.
- ② Insert new tines, and tighten the “10 stainless steel hexagon socket head special bolt 30” to completely secure the tines.

7-2 Bearing

⚠ Warning

- When disassembling the crank section to replace bearings, exercise care so as not to have your fingers or hands caught in the crank metal fittings. Right after the crank section is separated, the respective crank metal fittings will rotate by their own weight.

⚠ Caution

- When crank metal fittings are set out of position, vibration and noise will be generated, possibly damaging the machine.
- Respective crank metal fittings are attached in a 60-degree turned state to ensure right timing. Follow the assembling timing ① - ⑥ shown in “10. Timing chart. (P.17)”

7-3 Location of machine number plate

The model and serial number are punched on the machine number plate. The plate is attached to the front of the left side of the frame.

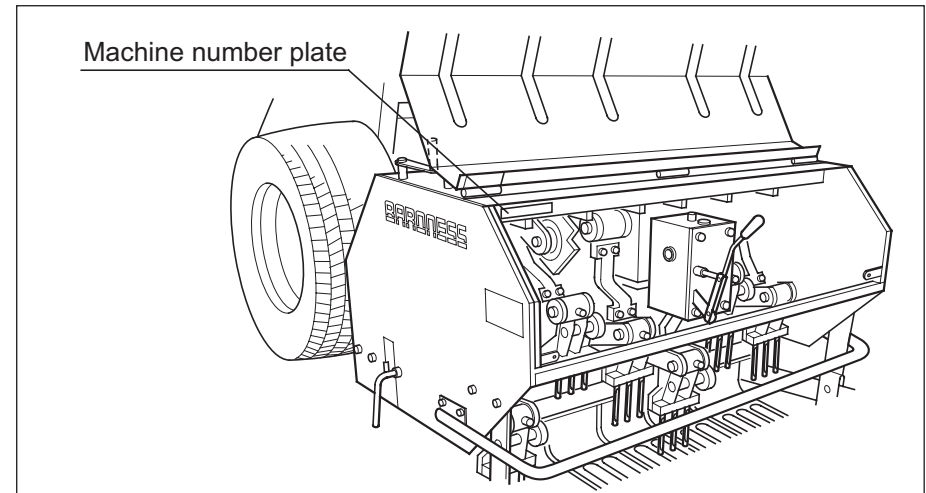

7-4 Specification sheet for maintenance

Qty of oil in gearbox	3.8 L (dm ³) (Gear oil VG680)
-----------------------	---

8. Long-term storage



① For the storage of the tractor, refer to the operation manual of the tractor.

- ② Clean the machine, and apply grease and oil to respective sliding sections.
- ③ Check the machine for loose or missing bolts and nuts. If they are loose, tighten them or repair the part.
- ④ Repair nonconforming sections and other sections where the paint has come off.
- ⑤ Cover the machine and put it in a dry place not exposed to the rain.

9. Maintenance schedule



Refer to the operation manual of the tractor for maintenance of the tractor.

- ...Inspection, adjustment, replenishment, and cleaning
- ...Replacement

Maintenance item	Before use	Every 50 hours	Every 300 hours	Remarks
Condition of tines	○			(*)
Loose screws in respective sections	○			
Greasing		○		
Change of oil in gearbox			●	100 hours after initial operation
Removal of dust, etc.	○			

*When cracks, damage, or abrasion is found in some part before use, replace it immediately.

Use appropriate maintenance tools.

Be sure to observe the precautions for inspection and maintenance (p.4 and p.9).

10. Timing chart

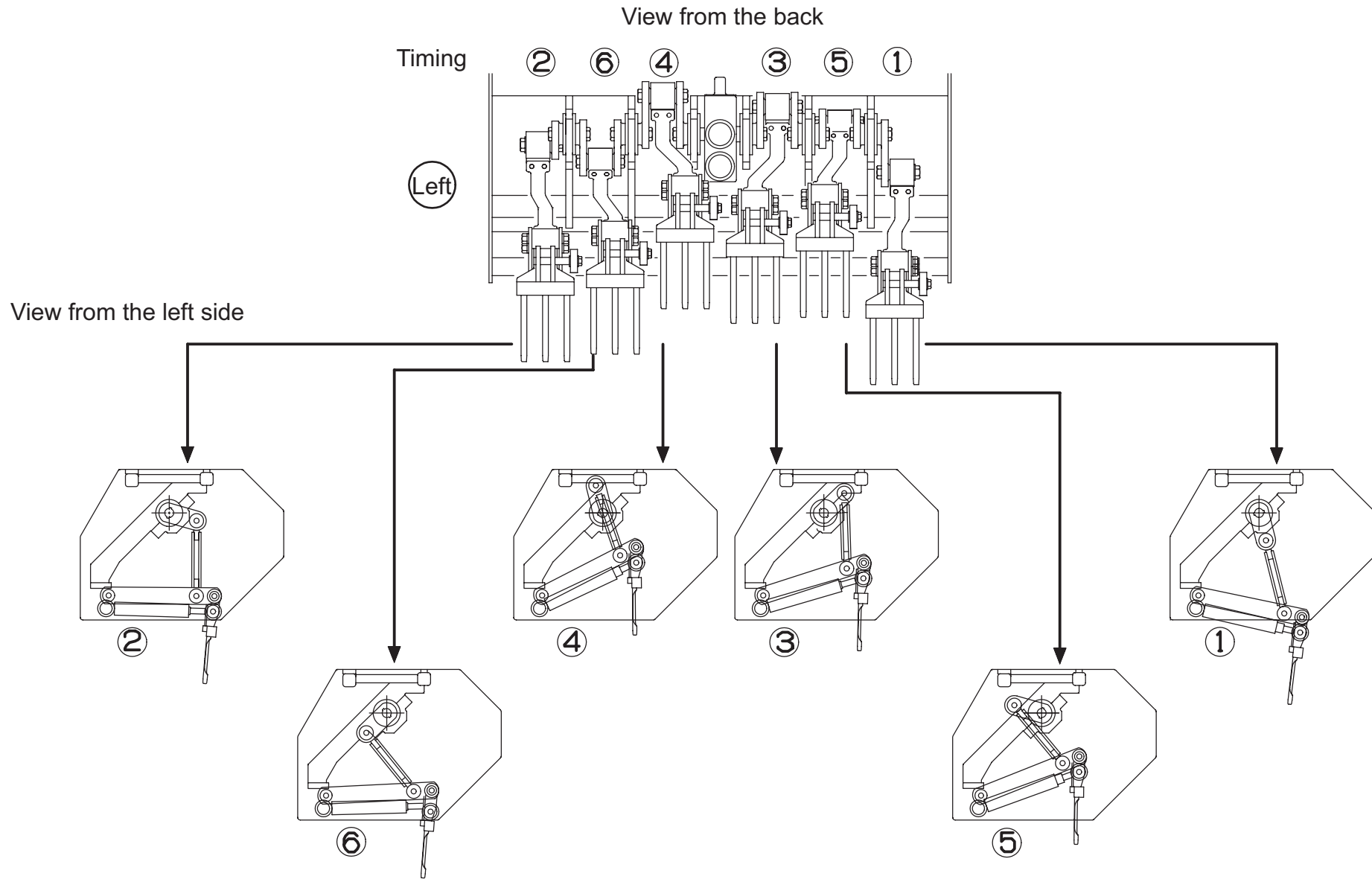

 **KYOEISHA CO., LTD.**
Head Office 1-26, Miyuki-cho, Toyokawa,
Aichi-Pref. 442-8530 Japan.

BARONESS
Turf Care Machinery
Tel : (0533)84-1221
Fax : (0533)84-1220