

LS62 · LS66

Standard Mower Unit

Owner's Operating Manual

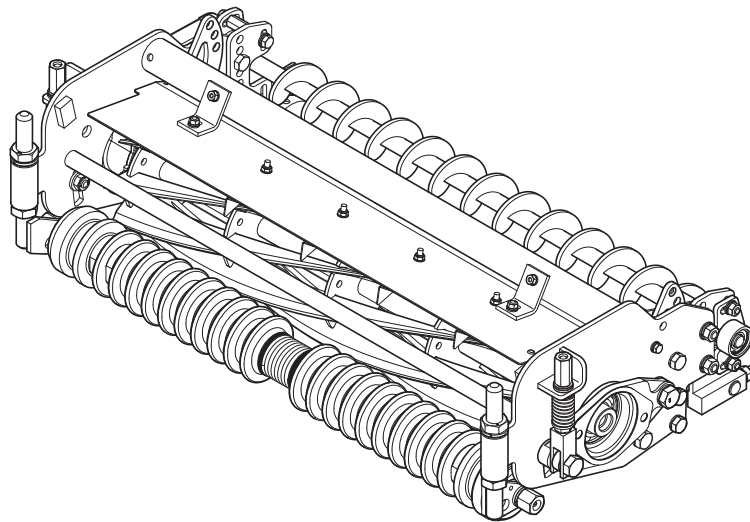

Serial No. LS62 : 10221- · LS66 : 10757-

"Required reading"
Read this manual before using the machine.

BARONESS[®]
Quality on Demand

Original Instructions Ver.1.4

Greeting

Thank you for purchasing the Baroness product. This manual describes the proper handling, adjustment, and inspection of your product. We hope you will use the product safely, and take advantage of its best performance. For details on the handling, adjustment and inspection of the main vehicle, refer to the Owner's Operating Manual for the main vehicle.

Read this manual carefully to ensure that you thoroughly understand how to properly operate and maintain the product, and to avoid causing injury to yourself or others.

The operator is responsible for operating the product properly and safely.

Maintenance service for this machine should be performed by a mechanic with expertise.

If you have any questions concerning maintenance or genuine parts, please contact a Baroness dealer or Kyoisha.





When making inquiries about the product, please specify the product's model designation and serial number.

When loaning or transferring the product, please also provide this manual together with the product.

Kyoisha Co., Ltd.

Warning Symbols

This manual uses the following warning symbols for handling precautions that are important for your safety.

 <p style="text-align: center;">696cq5-001</p>	<p>Warning symbol</p>
<p>This symbol indicates the articles regarding “Danger,” “Warning,” or “Caution.” Those articles describe important safety precautions and so read them carefully to understand completely before operating the machine.</p> <p>Failure to adequately follow these safety precautions may cause an accident.</p>	
<p> Danger</p> <p>This symbol indicates that serious injury or death will occur if the warning is ignored.</p> <p> Warning</p> <p>This symbol indicates that serious injury or death may occur if the warning is ignored.</p> <p> Caution</p> <p>This symbol indicates that injury or damage to property may occur if the warning is ignored.</p> <p>Important</p> <p>This symbol indicates precautions on the mechanism of the machine.</p>	

Introduction

Precautionary Statement

 Caution

The information described in this manual is subject to change for improvement without prior notice.

When replacing parts, be sure to use genuine Baroness parts or parts designated by Kyoisha.

Note that the Baroness product warranty may not apply to defects caused by the use of parts from other companies.

Prior to use, carefully read the following manuals to thoroughly understand the contents for safe and correct operation.

- Baroness Owner's Operating Manual

Purpose

This mower unit is intended for cutting turf grass at golf courses.

Do not use this machine in any way other than its intended purpose, and do not modify the machine.

Operating this mower unit for other purposes and modifying it may be very dangerous and may cause damage to the machine.

Safety	Page 1-1
Safe Operating Practices	Page 1-2
Disposal	Page 2-1
Recycle and Waste Disposal	Page 2-2
Product Overview	Page 3-1
Specifications	Page 3-2
Names of Each Section	Page 3-3
Regulation Decals	Page 3-3
Safety Signs and Instruction Signs	Page 3-4
Handling Instructions	Page 4-1
Handling Precautions	Page 4-2
Inspections	Page 4-2
Tightening Torques	Page 4-4
Adjustment before Work	Page 4-7
Storage	Page 4-12
Maintenance	Page 5-1
Maintenance Precautions	Page 5-2
Maintenance Schedule	Page 5-2
Greasing	Page 5-4
Maintenance Work	Page 5-5

Contents

Safe Operating Practices Page 1-2

Safety

Safety

Failure to adequately follow these safety precautions may cause an accident resulting in injury or death.

⚠ Danger

This product is designed to ensure safe operation and has been tested and inspected thoroughly before shipment from the factory. The product is equipped with safety devices to prevent accidents.

However, whether the product demonstrates its original performance level depends on the manner in which it is operated and handled, as well as the manner in which it is managed on a daily basis.

Inappropriate use or management of the product may result in injury or death.

Observe the following safety instructions to ensure safe operation.

Safe Operating Practices

Read Safe Operating Practices described in the Owner's Operating Manual of Baroness main vehicle equipped with this mower unit thoroughly.

Recycle and Waste Disposal Page 2-2

About RecyclePage 2-2

About Waste Disposal Page 2-2

Disposal

Disposal

Recycle and Waste Disposal

About Recycle

Recycling battery etc. is recommended for environmental conservation and economical use of resources.

It may be required by local laws.

About Waste Disposal

Make sure that waste generated when servicing or repairing the machine is disposed of in accordance with local regulations. (e.g. waste oil, antifreeze, rubber products, and wires etc.)

Specifications Page 3-2

Specifications List Page 3-2

Features of the STD Mower Unit Page 3-3

Names of Each Section Page 3-3

Regulation DecalsPage 3-3

Positions of Regulation Decals Page 3-3

Description of Regulation Decals Page 3-3

Safety Signs and Instruction Signs Page 3-4

About Safety Decals and Instruction
DecalsPage 3-4

Positions of Safety Decals and
Instruction Decals Page 3-4

Description of Safety Decals and
Instruction Decals Page 3-4



Product Overview

Specifications

Specifications List

LS62

Model		LS62			
Type		Base unit (incl. one weight)		With CR brush	
Dimensions	Total length	16.54 in	420 mm	16.54 in	420 mm
	Total width	29.72 in	755 mm	30.55 in	776 mm
	Total height	9.17 in	233 mm	9.17 in	233 mm
Weight	Mower Unit	110.23 lb	50.0 kg	114.64 lb	52.0 kg
	Weight (one piece)	4.41 lb	2.0 kg	—	—
	CR brush	—	—	11.02 lb	5.0 kg
Operating height (Mowing height)		0.394 - 1.811 in	10.0 - 46.0 mm	0.394 - 1.811 in	10.0 - 46.0 mm
Operating width (Mowing width)		22 in	557.5 mm	22 in	557.5 mm
Diameter of the reel cutter		6.4 in	163 mm	6.4 in	163 mm
Blades		9		9	

LS66

Model		LS66			
Type		Base unit (incl. one weight)		With CR brush	
Dimensions	Total length	16.54 in	420 mm	16.54 in	420 mm
	Total width	33.74 in	857 mm	34.61 in	879 mm
	Total height	9.17 in	233 mm	9.17 in	233 mm
Weight	Mower Unit	116.84 lb	53.0 kg	123.46 lb	56.0 kg
	Weight (one piece)	4.41 lb	2.0 kg	—	—
	CR brush	—	—	11.02 lb	5.0 kg
Operating height (Mowing height)		0.394 - 1.811 in	10.0 - 46.0 mm	0.394 - 1.811 in	10.0 - 46.0 mm
Operating width (Mowing width)		26 in	660 mm	26 in	660 mm
Diameter of the reel cutter		6.4 in	163 mm	6.4 in	163 mm
Blades		5 • 7 • 9		5 • 7 • 9	

Product Overview

Features of the STD Mower Unit

1. Equipped with a 6.4-inch (163 mm) - diameter reel cutter (cutting cylinder).
2. Blade engagement can be adjusted by changing the reel cutter (cutting cylinder) position without changing the position and angle of the bed knife (bottom blade), and therefore the bed knife attitude does not change due to wear of the reel cutter.
3. The front roller is a grooved roller that will not press down the lawn.
4. Grass clippings can be discharged either forward or backward.
5. The grass catcher can be installed.
6. The CR brush can be installed onto the rear roller.
7. The scraper can be installed on the front and rear roller.

1	Reel cover
2	Reel cutter
3	Bed knife
4	Front roller
5	Rear roller
6	CR brush

Regulation Decals

Positions of Regulation Decals

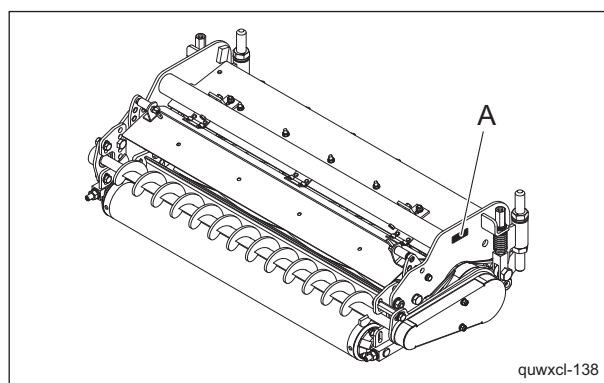

Positions of Regulation Decals_001

A	Serial number plate
---	---------------------

Description of Regulation Decals

Serial Number Plate

The serial number plate indicates the model and serial number of the machine.

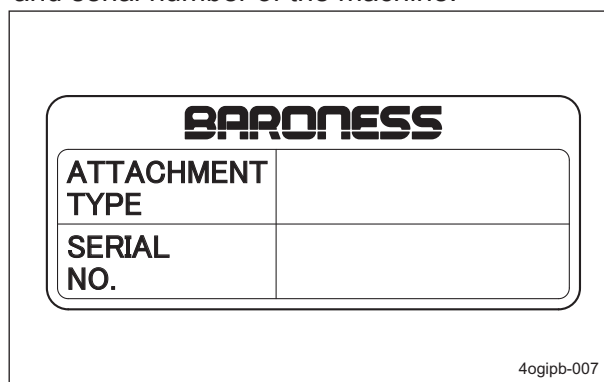

Serial Number Plate_001

Names of Each Section

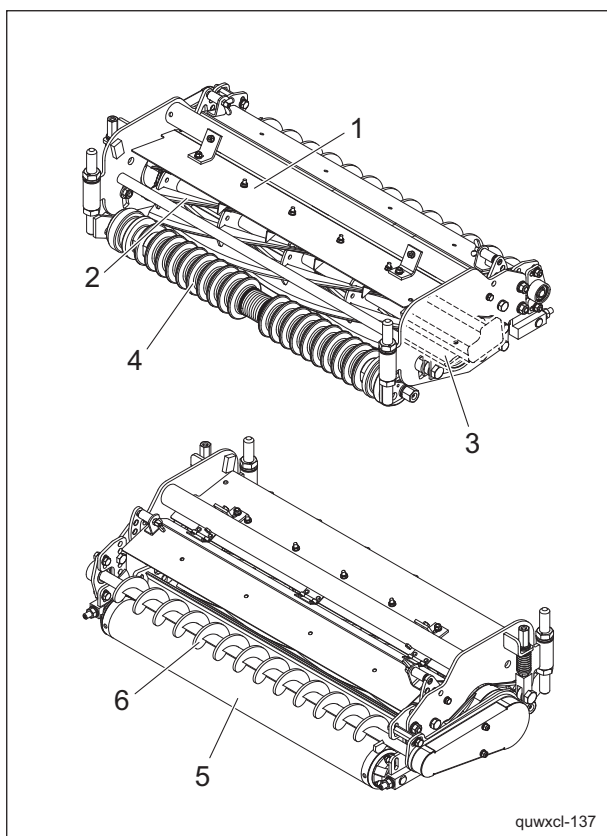

Names of Each Section_001

Product Overview

Safety Signs and Instruction Signs

About Safety Decals and Instruction Decals

Important

Safety decals and instruction decals are attached to this mower unit. Make sure that decals are preserved in their entirety. If they are damaged, become dirty, or peel off, replace them with new ones.

Part numbers for decals that need to be replaced are listed in the parts catalog. Order them from a Baroness dealer or Kyoeshia.

Positions of Safety Decals and Instruction Decals

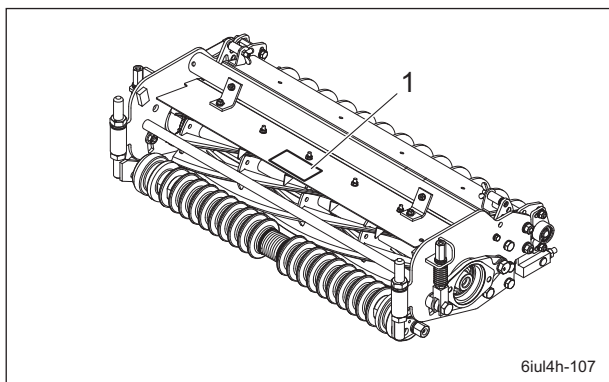

Positions of Safety Decals and Instruction Decals_001

1	Caution to mutilation decal
---	-----------------------------

Description of Safety Decals and Instruction Decals

Caution to Mutilation Decal

K4205001600
DECAL, CAUTION TO MUTILATION

Warning

May cut your hand or leg - Stop the cutter rotation and engine. Otherwise you may get injured.

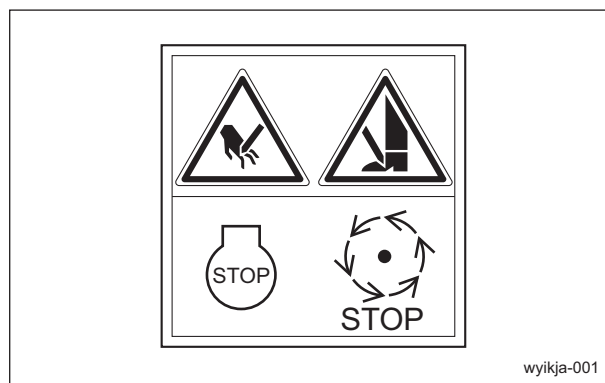

Caution to Mutilation Decal_001

Handling Precautions Page 4-2

Inspections Page 4-2

Reel Cutter (Cutting Cylinder) and Bed Knife (Bottom Blade)	Page 4-2
Cover	Page 4-2
Belt	Page 4-2
Roller	Page 4-3
CR brush	Page 4-3
Scraper	Page 4-3

Tightening Torques Page 4-4

Standard Tightening Torques	Page 4-4
Principal Tightening Torques	Page 4-6

Adjustment before Work Page 4-7

Adjustment of Blade Engagement	Page 4-7
Adjustment of Cutting Height	Page 4-8
Adjustment of Cutter Adjustment Spring	Page 4-9
Adjustment of Reel Cover (Variable Type)	Page 4-9
Adjustment of Reel Cover (Variable Easy Latch Type)	Page 4-10
Adjustment of CR Brush	Page 4-10
Adjustment of Scraper	Page 4-11

Storage Page 4-12

Before Long-Term Storage	Page 4-12
--------------------------------	-----------

Handling Instructions

Handling Precautions

Important

This manual contains descriptions for handling the mower unit.

For details on handling the main vehicle, refer to this manual and the Owner's Operating Manual for the main vehicle.

Inspections

Inspect the machine according to the maintenance schedule so that you will be able to take advantage of its optimum performance for a long period of time.

Reel Cutter (Cutting Cylinder) and Bed Knife (Bottom Blade)

Inspection of Reel Cutter (Cutting Cylinder) and Bed Knife (Bottom Blade)

Caution

Wear gloves when touching edged tools to avoid cutting your hands.

The reel cutter (cutting cylinder) and bed knife (bottom blade) may become dull due to frequent use, objects crushed during mowing, or damage caused during transportation. Inspect the reel cutter (cutting cylinder) and bed knife (bottom blade), and if necessary, adjust the blade engagement, perform back lapping, or sharpen or replace the reel cutter (cutting cylinder) and the bed knife (bottom blade).

1. Check to see whether or not the edge of the reel cutter (cutting cylinder) and the bed knife (bottom blade) are too blunt to cut.
2. Make sure that the reel cutter (cutting cylinder) and the bed knife (bottom blade) are not cracked.
3. Check to see how much the reel cutter (cutting cylinder) and the bed knife (bottom blade) are worn.
4. Make sure that the reel cutter (cutting cylinder) and the bed knife (bottom blade) have not changed color due to heat from grinding.
5. Check to see whether or not the second edge face (relief) remains at the point of reel cutter (cutting cylinder).

6. Make sure that the welding between the reel cutter (cutting cylinder) and the disc has not come off.

Cover

Inspection of Covers

Warning

If you have removed the covers during inspection, be sure to securely install them in their original positions.

If a cover remains removed, the operator may come into contact with rotating parts or belts and foreign objects may fly off, possibly resulting in injuries.

1. Make sure that there is no wear or deterioration of the reel cover and all other covers.
2. Make sure that there is no damage to the reel cover and all other covers.
3. Make sure that there is no interference with moving parts due to deformation of the reel cover and all other covers.
4. Make sure that the reel cover and all other covers are installed in their appropriate positions.

Belt

Inspection of Belt

Caution

The engine must be stopped when the belt is inspected.

Caution

If you have removed the cover during inspection, make sure that you replace it in the original position securely.

If the cover remains removed, the operator may come in contact with the rotating objects or belt, possibly resulting in injuries.

1. Press the middle of the belt with your finger to check the belt tension.
2. Make sure that there are no cracks, damage or abnormal wear.

Handling Instructions

Roller

Inspection of Rollers

Bearing wear due to frequent use or bearing damage caused by water infiltration may prevent the roller from rotating smoothly. Inspect the roller and, if necessary, replace parts such as oil seals and bearings.

1. Make sure that there is no abrasion nor adhesion of the roller.
2. Make sure that there is no wear of the roller shaft.
3. Make sure that there is no wear nor damage of the oil seal.
4. Make sure that there is no wear nor rust of the bearing.
5. Make sure that there is no play in the roller shaft.

CR brush

Inspection of CR Brush

Note:

Depending on the specifications, this function may not be available.

Bearing wear due to frequent use or bearing damage caused by water infiltration may prevent the brush from rotating smoothly. Inspect the brush and, if necessary, replace parts such as bearings.

1. Make sure that there is no abrasion nor adhesion of the brush.
2. Make sure that there is no wear of the brush shaft.
3. Make sure that there is no abnormality in the brush.
4. Make sure that there is no play in the fit of the bearing and the housing.
5. Make sure that there is no play in the brush shaft.

Scraper

Inspection of Scraper

■ Inspection of Front Scraper

Note:

Depending on the specifications, this function may not be available.

The operating efficiency may be reduced due to frequent use, objects crushed during operation, or damage during transportation. Inspect the scraper, and replace any parts if necessary.

1. Make sure that there is no damage nor deformation of the scraper.
2. Make sure that there is no contact between the scraper and roller.

■ Inspection of Rear Scraper (Wire Type)

Note:

Depending on the specifications, this function may not be available.

The operating efficiency may be reduced due to frequent use, objects crushed during operation, or damage during transportation. Inspect the scraper, and replace any parts if necessary.

1. Make sure that there are no breaks nor sagging in the scraper (wire).
2. Make sure that there is no contact between the scraper and roller.

Handling Instructions

Tightening Torques

Important

Refer to the Tightening Torque table.
Note that the Baroness product warranty may not apply to defects caused by incorrect or overtorque tightening, etc.

Standard Tightening Torques

Bolts and Nuts

Important

A number of bolts are used in each part of this machine.
Be sure to re-tighten the bolts and nuts, because they may be loosened at the earlier stage of the use.

As to the bolts and nuts without any special instruction, tighten them in appropriate tightening torque with proper tool.

Too much tightening may cause the looseness or damage of the screw.

The strength of tightening is determined by types of screws, strength, the friction of thread face or base face and others.

The table below is for the galvanized or parkerized bolts.

In case that the strength of internal thread is weak, it is not applied.

Do not use rusty or sand attached "screw."

Otherwise, it may cause insufficient tightening even if you apply the specified tightening torque.

The friction of the screw face becomes higher and the tightening torque is canceled out by the friction, therefore sufficient tightening cannot be applied.

If "screw" is wet by water or oil, do not tighten it with normal tightening torque.

If the screw is wet, the torque coefficient will get smaller and it may result in too much tightening.

Too much tightening may cause looseness by the screw stretched or result in damage.



Do not use a bolt experienced too much burden.

Using the impact wrench requires the skill.

Do exercise as much as possible for steady tightening.

Handling Instructions

Nominal diameter	General bolt		
	Strength classification 4.8		
	 tib3yb-001		
	N-m	kgf-cm	lb-in
M5	3 - 5	30.59 - 50.99	26.55 - 44.26
M6	7 - 9	71.38 - 91.77	61.96 - 79.66
M8	14 - 19	142.76 - 193.74	123.91 - 168.17
M10	29 - 38	295.71 - 387.49	256.68 - 336.34
M12	52 - 67	530.24 - 683.20	460.25 - 593.02
M14	70 - 94	713.79 - 958.52	619.57 - 831.99
M16	88 - 112	897.34 - 1142.06	778.89 - 991.31
M18	116 - 144	1,182.85 - 1,468.37	1,026.72 - 1,274.54
M20	147 - 183	1,498.96 - 1,866.05	1,301.10 - 1,619.73
M22	295	3,008.12	2,611.05
M24	370	3,772.89	3,274.87
M27	550	5,608.35	4,868.05
M30	740	7,545.78	6,549.74

Nominal diameter	Heat-treated bolt					
	Strength classification 8.8			Strength classification 10.9		
	 tib3yb-002			 tib3yb-003		
	N-m	kgf-cm	lb-in	N-m	kgf-cm	lb-in
M5	5 - 7	50.99 - 71.38	44.26 - 61.96	7 - 10	71.38 - 101.97	61.96 - 88.51
M6	8 - 11	81.58 - 112.17	70.81 - 97.36	14 - 18	142.76 - 183.55	123.91 - 159.32
M8	23 - 29	234.53 - 295.71	203.57 - 256.68	28 - 38	285.52 - 387.49	247.83 - 336.34
M10	45 - 57	458.87 - 581.23	398.30 - 504.51	58 - 76	591.43 - 774.97	513.36 - 672.68
M12	67 - 85	683.20 - 866.75	593.02 - 752.34	104 - 134	1,060.49 - 1,366.40	920.50 - 1186.03
M14	106 - 134	1,080.88 - 1,366.40	938.21 - 1,186.03	140 - 188	1,427.58 - 1,917.04	1,239.14 - 1,663.99
M16	152 - 188	1,549.94 - 1,917.04	1,345.35 - 1,663.99	210 - 260	2,141.37 - 2,651.22	1,858.71 - 2,301.26
M18	200 - 240	2,039.40 - 2,447.28	1,770.20 - 2,124.24	280 - 340	2,855.16 - 3,466.98	2,478.28 - 3,009.34
M20	245 - 295	2,498.27 - 3,008.12	2,168.50 - 2,611.05	370 - 450	3,772.89 - 4,588.65	3,274.87 - 3,982.95
M22	-	-	-	530	5,404.41	4,691.03
M24	-	-	-	670	6,831.99	5,930.17
M27	-	-	-	1,000	10,197.00	8,851.00
M30	-	-	-	1,340	14,628.78	11,860.34

Note:
The same values are applied to "fine screw thread."

Handling Instructions

Principal Tightening Torques

Tightening Torque by Model

LS66/LS62

Tighten the following bolts and nuts at the torque specified in the table.

For thread locking adhesive, apply a middle strength thread locker (ThreeBond 1322 or equivalent anaerobic sealant).

Location	Code	Part name	Tightening torque			Thread locking adhesive
			N-m	kgf-cm	lb-in	
Bed knife	K0071001182	SCREW, HT FLAT HEAD M10-16	29 - 38	295.71 - 387.49	256.68 - 336.34	-

Handling Instructions

Adjustment before Work

Adjustment of Blade Engagement

Warning

Make sure that the parking brake is firmly applied before performing the operation.

Caution

Be sure to perform this operation on your own.

Caution

When handling the reel cutter (cutting cylinder) or bed knife (bottom blade), wear gloves to protect your hands. However, pay attention not to let the reel cutter (cutting cylinder) catch your gloves, etc. Otherwise, you may injure your hand or fingers.

Important

If the CR brush is installed, loosen the left and right bolts and nuts used to install the CR brush before adjusting the blade engagement. After adjusting the blade engagement, adjust the CR brush, and then firmly tighten the loosened bolts and nuts.

1. Stop the engine.
2. Shift the reel rotation/stop switching lever to the "Stop" position.

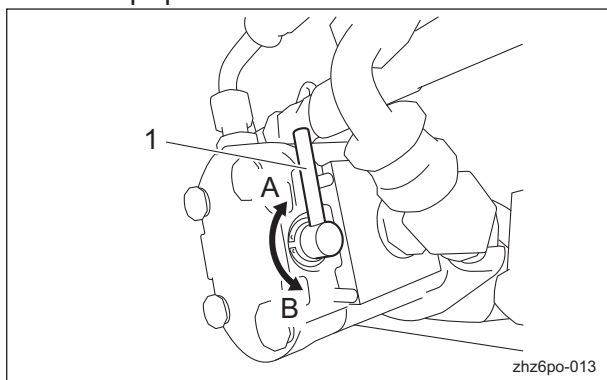

Adjustment of Blade Engagement_001

1	Reel rotation/stop switching lever
A	Rotation
B	Stop

3. With the cutter adjustment nut, adjust the engagement between the reel cutter (cutting cylinder) and the bed knife (bottom blade) so that newspaper (two to three sheets) will be cut by the edge of both blades when the blades in their entirety come slightly into contact with each other.
4. Insert two or three strips of newspaper into the space between the reel cutter (cutting cylinder) and the bed knife (bottom blade) at an angle of 90 degrees. Then, rotate the reel cutter (cutting cylinder) counterclockwise (as seen from the left side of the mower unit) by hand to check the sharpness. Check the sharpness of the entire range (at three or four points) of the reel cutter (cutting cylinder).

- If there is a gap between the blade edges: Loosen (rotate counter-clockwise) the cutter adjustment nut to apply more contact pressure between the reel cutter (cutting cylinder) and the bed knife (bottom blade).
- If the reel cutter (cutting cylinder) is too tight to turn: Tighten (rotate clockwise) the cutter adjustment nut to reduce the contact pressure between the reel cutter (cutting cylinder) and the bed knife (bottom blade).
- If the blades still cannot cut well: Perform back lapping of the reel cutter (cutting cylinder) and the bed knife (bottom blade).

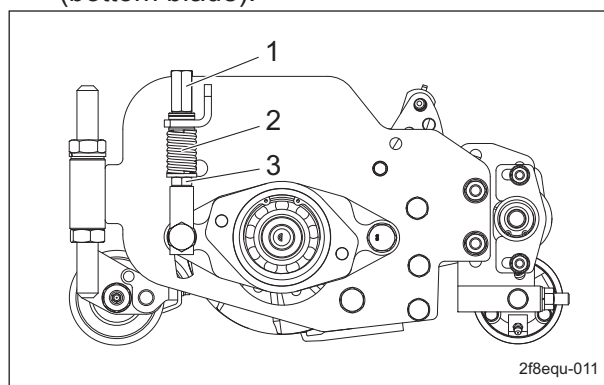

Adjustment of Blade Engagement_002

1	Cutter adjustment nut
2	Spring
3	Pipe with cutter adjustment screw

Handling Instructions

Adjustment of Cutting Height

Cutting Height Adjustment

⚠ Caution

Do not perform the operation with any other persons.

Adjust the cutting height to fit your cutting work.
The rear roller can be adjusted to one of four settings.

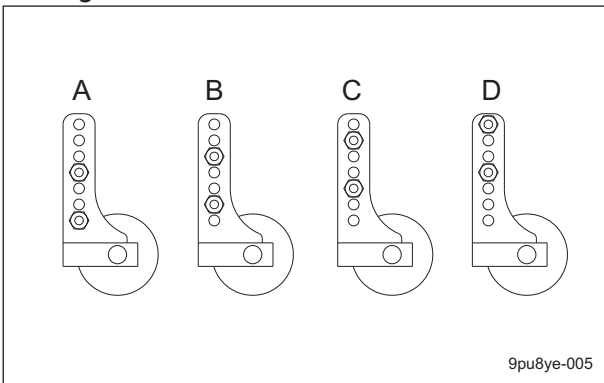

9pu8ye-005

Cutting Height Adjustment_001

A	10 - 17 mm (0.39 - 0.67 in)
B	10 - 33 mm (0.39 - 1.30 in)
C	21 - 39 mm (0.83 - 1.54 in)
D	28 - 46 mm (1.10 - 1.81 in)

Note:

With the same cutting height for settings A and B, the clippings volume with B will be larger since the offset distance is longer. The same goes for settings B and C and settings C and D.

1. Attach the rear roller in a position that suits your work requirements within the cutting height range.

2. Set the slide caliper to the required cutting height, adjust the neck position of the small screw for cutting height setup of the cutting height gauge and securely lock with a fly nut.

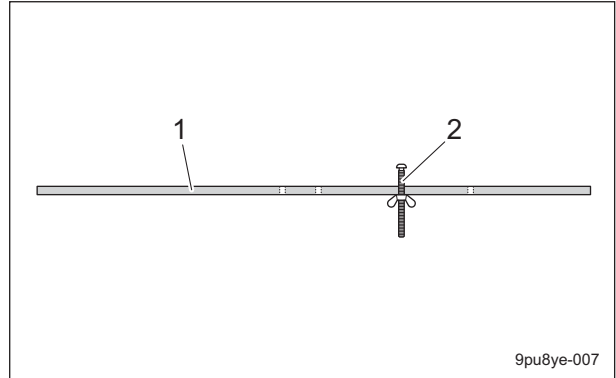

9pu8ye-007

Cutting Height Adjustment_002

1	Cutting height gauge
2	Small screw for cutting height setup

- Loosen the nut which fixes the roller bracket of the front roller.
- Apply the cutting height gauge to the front and rear rollers at each edge of left and right of the mower unit.
- Adjust the front roller up and down by the roller adjuster to determine the position of the front roller, in order not to have a gap with the neck position of the small screw for cutting height setup of the cutting height gauge, at the edge of the bed knife.

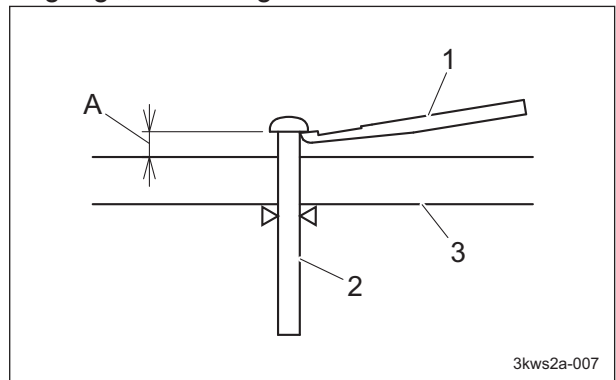

3kws2a-007

Cutting Height Adjustment_003

1	Bed knife (bottom blade)
2	Small screw for cutting height setup
3	Cutting height gauge
A	Cutting height

Handling Instructions

- To increase cutting height:
 - [1] Loosen cutting height adjustment nut A, tighten cutting height adjustment nut B, and then lower the front roller.
 - [2] Use the cutting height gauge to determine the cutting position, and then firmly tighten cutting height adjustment nut A.
- To decrease cutting height:
 - [1] Loosen cutting height adjustment nut B, tighten cutting height adjustment nut A, and then raise the front roller.
 - [2] Use the cutting height gauge to determine the cutting position, and then firmly tighten cutting height adjustment nut B.

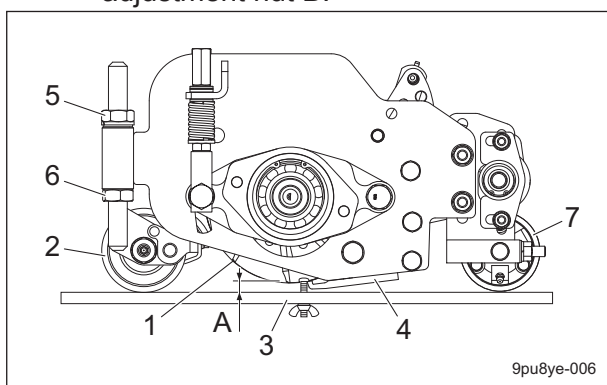

Cutting Height Adjustment_004

1	Reel cutter (cutting cylinder)
2	Front roller
3	Cutting height gauge
4	Bed knife (bottom blade)
5	Cutting height adjustment nut A
6	Cutting height adjustment nut B
7	Rear roller
A	Cutting height

6. Repeat the same process at the opposite side for the adjustment of cutting height.
7. Again, make sure that the cutting height is at the required position by applying the cutting height gauge to the front and rear rollers at each edge of right and left of the mower unit.

Adjustment of Cutter Adjustment Spring

If the diameter of the reel cutter (cutting cylinder) becomes smaller, adjust the cutter adjustment spring.

1. Adjust the blade engagement.
2. Loosen the pipe with cutter adjusting screw, and then adjust the length of the spring coil to approximately 40 mm (1.575 in.).

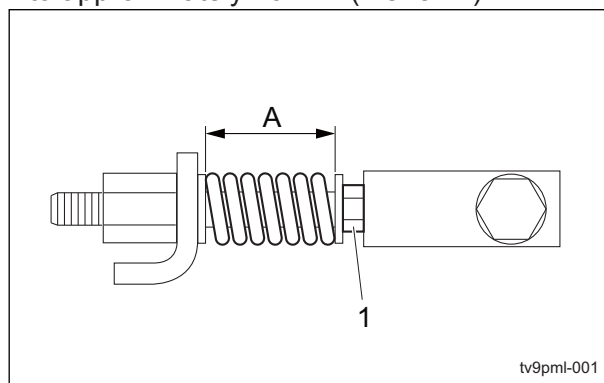

Adjustment of Cutter Adjustment Spring_001

1	Pipe with cutter adjusting screw
A	40 mm (1.575 in.)

Adjustment of Reel Cover (Variable Type)

Note:

Depending on the specifications, this function may not be available. The angle of the reel cover can be adjusted. The opening angle of the reel cover can be set to one of three positions in 15-degree increments.

1. Pull the left and right knobs securing the reel cover in order to release it.
2. Secure the reel cover to a different hole in the cover adjustment plate.

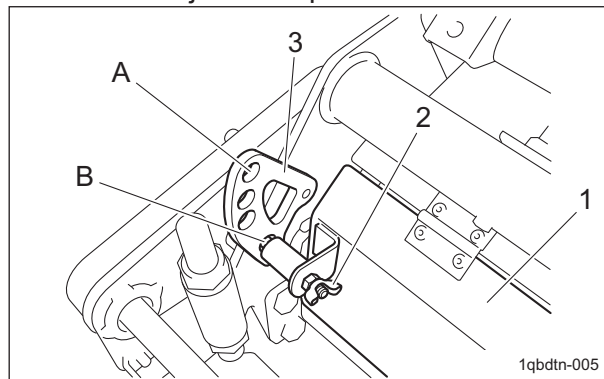

Adjustment of Reel Cover (Variable Type)_001

Handling Instructions

1	Reel cover
2	Knob
3	Cover adjustment plate
A	Fully open
B	Fully closed

Adjustment of Reel Cover (Variable Easy Latch Type)

Note:

Depending on the specifications, this function may not be available.
 The angle of the reel cover can be adjusted.
 The opening angle of the reel cover can be set to one of six positions in 12.5-degree increments.

1. Pull the rod connecting the left and right knobs securing the reel cover in order to release the cover.

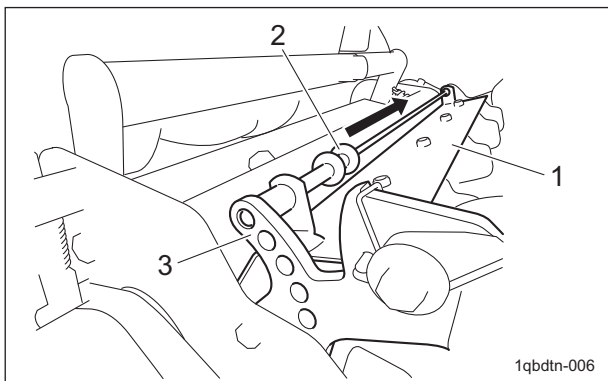

Adjustment of Reel Cover (Variable Easy Latch Type)_001

1	Reel cover
2	Rod
3	Cover adjustment plate

2. Secure the reel cover to a different hole in the cover adjustment plate.

Note:

If the fin is installed, the reel cover cannot be fully closed.

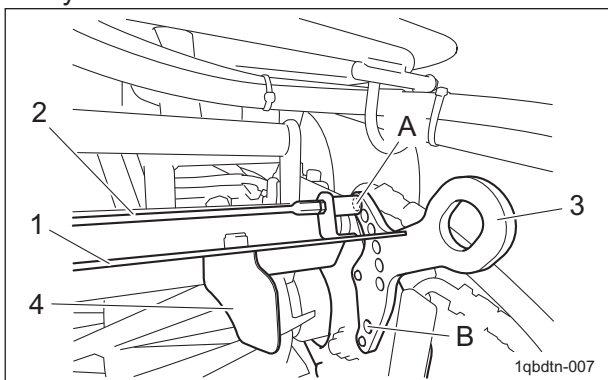

Adjustment of Reel Cover (Variable Easy Latch Type)_002

1	Reel cover
2	Rod
3	Cover adjustment plate
4	Fin
A	Fully open
B	Fully closed

Adjustment of CR Brush

Note:

Depending on the specifications, this function may not be available.

Important

Do not place the brush in contact with the rear roller too tightly. It will cause belt slip and break.

Important

The rotating CR brush prevents grass clippings, etc., from attaching to the rear roller.

1. Loosen the bolts A, bolts B and nuts used to install the CR brush.
2. Adjust the CR brush so that there is a clearance of 0 to 1.0 mm (0 to 0.039 in) between it and the rear roller, and then firmly tighten the loosened bolts and nuts.

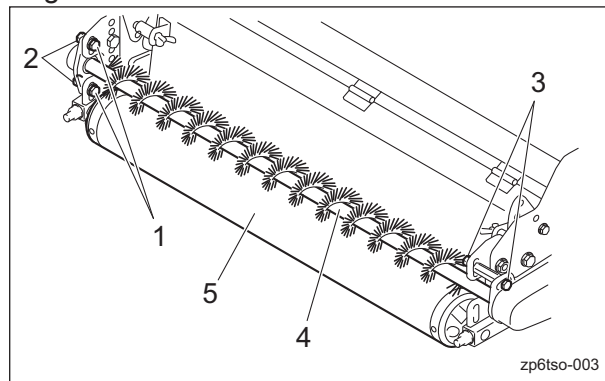

Adjustment of CR Brush_001

1	Bolt A
2	Nut
3	Bolt B
4	Brush
5	Rear roller

Handling Instructions

Adjustment of Scraper

Adjustment of Front Scraper

Note:
Depending on the specifications, this function may not be available.

Important

Do not place the scraper in contact with the front roller too tightly. It will cause deformation of the scraper and damage of the front roller.

The scraper prevents grass clippings, etc., from attaching to the front roller.

1. Loosen the left and right bolts of the scraper.

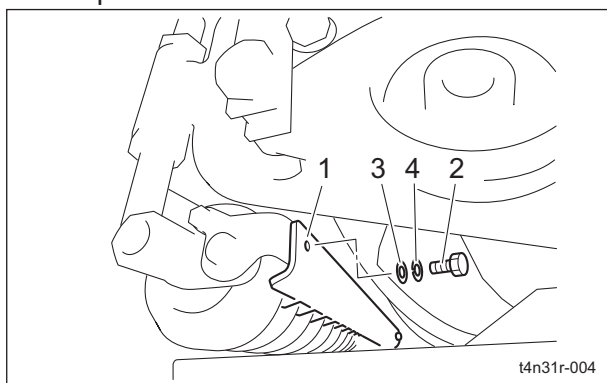

Adjustment of Front Scraper_001

1	Scraper
2	Bolt
3	Washer
4	Spring washer

2. Adjust the scraper so that there is a clearance of 2.0 to 3.0 mm (0.079 to 0.118 in) between it and the outer diameter surface of the front roller, and then firmly tighten the loosened bolts and nuts.

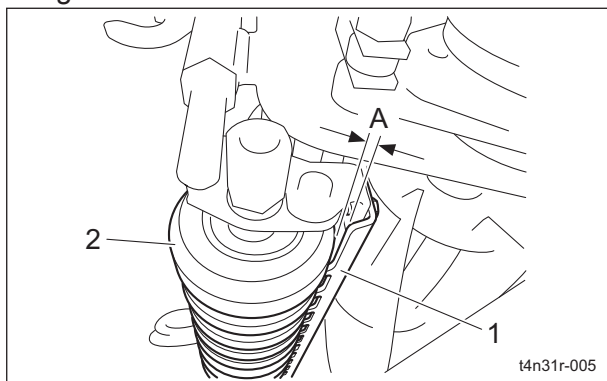

Adjustment of Front Scraper_002

1	Scraper
2	Front roller
A	2.0 - 3.0 mm (0.079 - 0.118 in)

Adjustment of Rear Scraper (Wire Type)

Note:
Depending on the specifications, this function may not be available.

Important

Do not place the scraper in contact with the rear roller too tightly. It will cause the scraper break and slack.

The scraper prevents grass clippings, etc., from attaching to the rear roller.

1. Loosen the left and right lock nuts and nuts of the scraper.
2. Adjust the scraper so that there is a clearance of 2.0 to 3.0 mm (0.079 to 0.118 in) between it and the rear roller, and then secure it with the lock nuts.

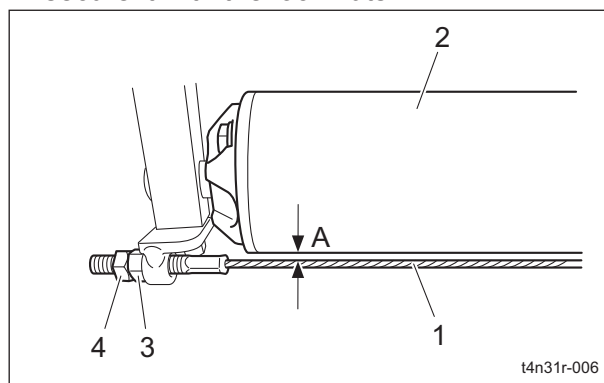

Adjustment of Rear Scraper (Wire Type)_001

1	Scraper
2	Rear roller
3	Nut
4	Lock nut
A	2.0 - 3.0 mm (0.079 - 0.118 in)

Handling Instructions

Storage

Before Long-Term Storage

1. Cleaning
 - Remove dirt, grass clippings, oil stains etc. completely.
2. Oil filling
 - Grease and lubricate the appropriate points.
3. Storage location
 - Cover the machine and store it in a dry place where it will not be exposed to rain.

Maintenance Precautions	Page 5-2
Maintenance Schedule	Page 5-2
Adjusted Values	Page 5-3
Greasing	Page 5-4
About Greasing	Page 5-4
Greasing Points	Page 5-4
Maintenance Work	Page 5-5
Cleaning of Mower Unit	Page 5-5
Back Lapping	Page 5-5
Sharpening of Reel Cutter (Cutting Cylinder)	Page 5-7
Replacement of Reel Cutter (Cutting Cylinder)	Page 5-8
Replacement of Bed Knife (Bottom Blade)	Page 5-9
Adjustment of Belt Tension	Page 5-10

Maintenance

Maintenance Precautions

Warning

The chapter "Maintenance" in this manual describes practical measures which should be performed by a mechanic with expertise. The owner should instruct the mechanic with expertise to perform maintenance service for this machine.

Caution

First, learn well the maintenance operations you plan to perform.

Important

Use tools appropriate for each maintenance operation.

Important

For the safe and best performance of your machine, use Baroness genuine parts for replacement and accessories. Please note that our product warranty may be void if you use non-genuine parts for replacement or accessories.

Maintain the machine according to the maintenance schedule so that you will be able to take advantage of its optimum performance for a long period of time.

Maintenance Schedule

LS62 • LS66

Follow the maintenance schedule below.

- . . . Inspect, adjust, supply, clean
- . . . Replace (first time)
- △ . . . Replace

Maintenance Item	Before Work	After Work	Every 10 hrs.	Every 50 hrs.	Every 250 hrs.	Every 500 hrs.	When Required	Remarks
Check blade condition (Reel cutter and Bed knife)	○							
Check cover condition	○							
Check roller condition	○							
Check CR brush condition	○							

Maintenance

Maintenance Item	Before Work	After Work	Every 10 hrs.	Every 50 hrs.	Every 250 hrs.	Every 500 hrs.	When Required	Remarks
Check scraper condition	<input type="radio"/>							
Check belt condition	<input type="radio"/>							
Check damaged parts	<input type="radio"/>							
Check tightening bolts and nuts	<input type="radio"/>							
Engage blades	<input type="radio"/>							
Check mowing height	<input type="radio"/>							
Adjust reel cover (Variable type)	<input type="radio"/>							
Adjust CR brush	<input type="radio"/>							
Adjust scraper	<input type="radio"/>							
Clean mower unit		<input type="radio"/>						
Backlap blades							<input type="radio"/>	
Grease				<input type="radio"/>				
Clean inside of CR brush belt cover				<input type="radio"/>				
Grease hydraulic motor shaft of mower unit					<input type="radio"/>			
Grease spindle bolt of reel housing						<input type="radio"/>		
Adjust cutter adjustment spring							<input type="radio"/>	
Adjust belt tension of CR brush							<input type="radio"/>	
Regrind blades (Reel cutter)							<input type="radio"/>	Grind/Replace blades as and when required

• The values for consumables are not guaranteed.

Adjusted Values

Cutter adjustment spring	40.0 mm (1.575 in.)	Length of spring coil
CR brush	0 - 1.0 mm (0 - 0.039 in)	Gap between brush and rear roller
Front scraper	2.0 - 3.0 mm (0.079 - 0.118 in)	Gap between scraper and outer diameter surface of roller
Rear scraper	2.0 - 3.0 mm (0.079 - 0.118 in)	Gap between scraper and roller
CR brush drive belt	5.0 - 6.0 mm (0.197 - 0.236 in)	Slack when belt pressed with 10.0 N (1.0 kgf) at the middle point between pulleys

Maintenance

Greasing

About Greasing

Since there may be adhesion or damage due to lack of grease on moving parts, they must be greased.

Add urea-based No. 2 grease in accordance with the Maintenance Schedule.

Other locations where the specified grease or lubricant is used are indicated in "Greasing Points".

Add grease using the specified grease or lubricant.

Greasing Points

Grease nipples are installed in the following locations.

Add grease every 50 hours of operation.

However, for locations where a time is specified, add grease according to that schedule.

	Location	No. of greasing points
1	Front roller shaft	2
2	Housing	2
3	Rear roller shaft	2

1. Front roller shaft

There is one point each on the left and right of the front roller shaft.

Left end of front roller

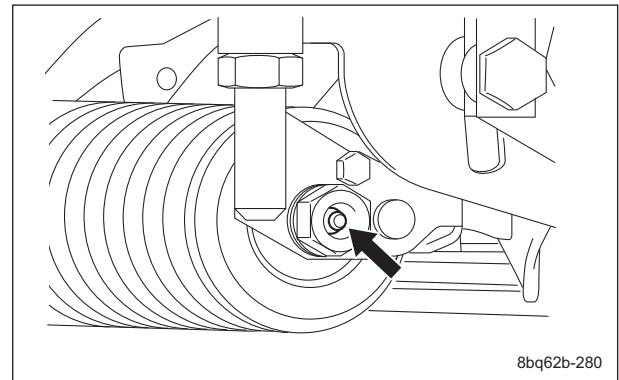

Greasing Points_002

Right end of front roller

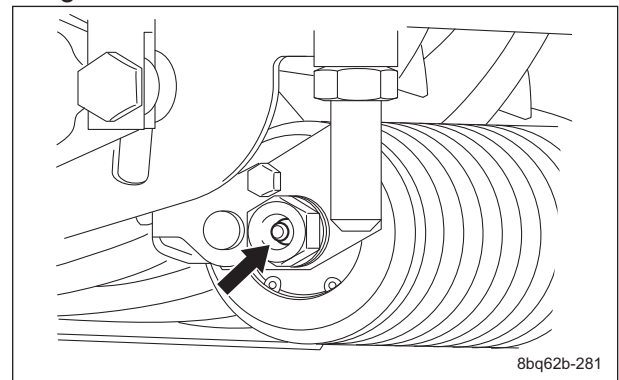

Greasing Points_003

2. Housing

There is one point each on the left and right of the housing.

Hydraulic motor housing side

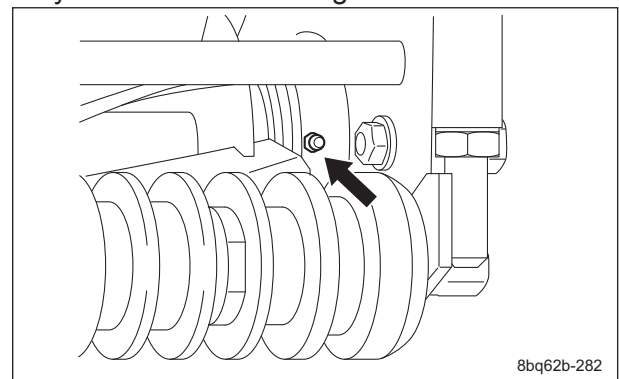

Greasing Points_004

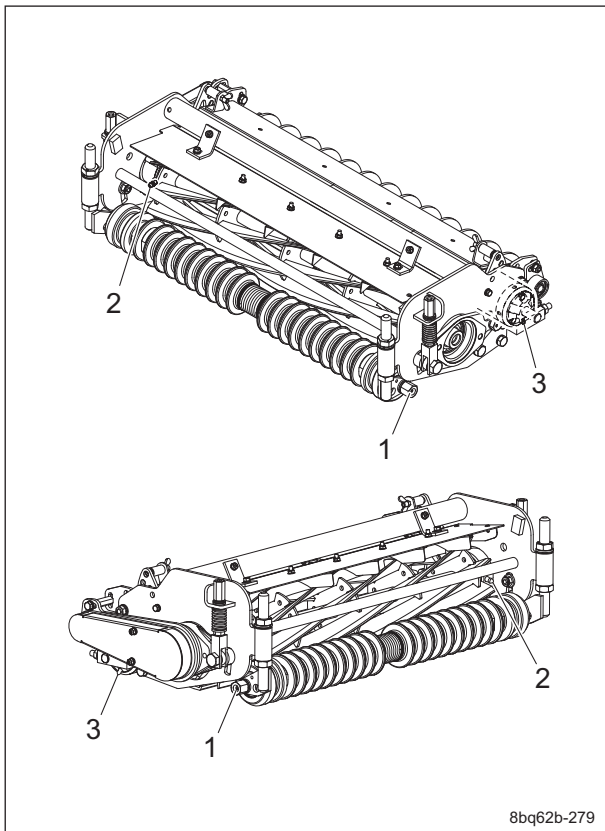

Greasing Points_001

Reel housing side

Important

Always use a hand operated grease gun and only add a maximum of 2 pumps of grease every 50 hours.

Using a power assisted grease gun should be avoided.

The grease capacity inside the reel housing on the CR brush mount side is approximately 25 g (0.05 lb).

If you repeat greasing by 2 g (0.004 lb) twelve times for 600 hours of operation, the grease amount inside the housing will almost reach its full capacity.

In case that the grease exceeds its capacity, the brush frame may project outward.

Therefore, remove the brush frame and discard the grease inside the reel housing when it reaches the capacity.

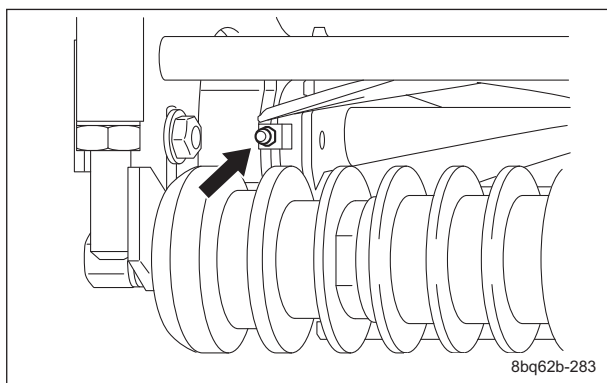

Greasing Points_005

3. Rear roller shaft

There is one point each on the left and right of the rear roller shaft.

Left end of rear roller

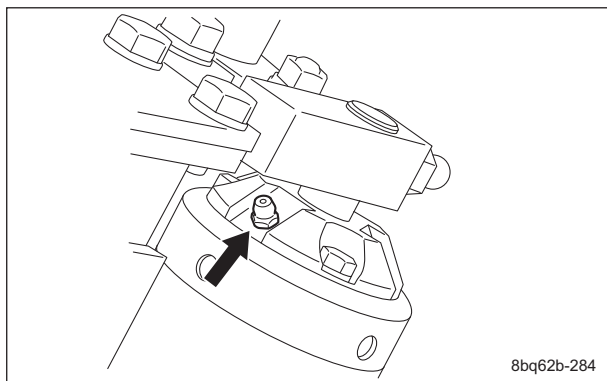

Greasing Points_006

Right end of rear roller

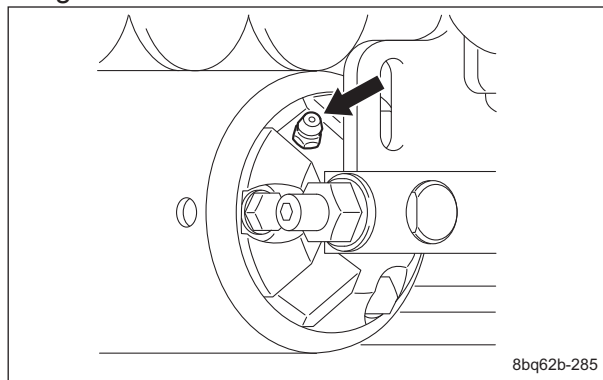

Greasing Points_007

Maintenance Work

Cleaning of Mower Unit

Important

While cleaning, do not allow water on the sealed parts of the reel shaft. (Avoid high-pressure water cleaning.)

Otherwise, it may cause damage to the machine.

Be sure to clean the mower unit after use.

1. Stop the engine, and then remove the key.
2. Carefully clean the front and back of the mower unit with water or compressed air.
3. Remove any grass wrapped around the reel cutter (cutting cylinder).

Back Lapping

Back lapping is work similar to sharpening a cooking knife. If the edges of the reel cutter (cutting cylinder) and the bed knife (bottom blade) become blunt and make cutting difficult, both the reel cutter (cutting cylinder) and the bed knife (bottom blade) should be simultaneously sharpened by reversing the reel cutter (cutting cylinder) with an abrasive paste applied.

However, back lapping is a temporary measure and would not restore the sharpness completely.

If the edges of the reel cutter (cutting cylinder) and the bed knife (bottom blade) become blunt and make cutting difficult, perform back lapping in the following procedure.

Maintenance

Warning

The reel cutter rotates during back lapping work.
Keep hands and feet away from moving parts.

Caution

Be careful not to inhale exhaust gas during back lapping.

Caution

Do not perform back lapping work with any other persons.

1. Prepare newspaper cut into strip, abrasive with back lapping powder mixed with oil or gel compound (Baroness genuine abrasive), and a brush.

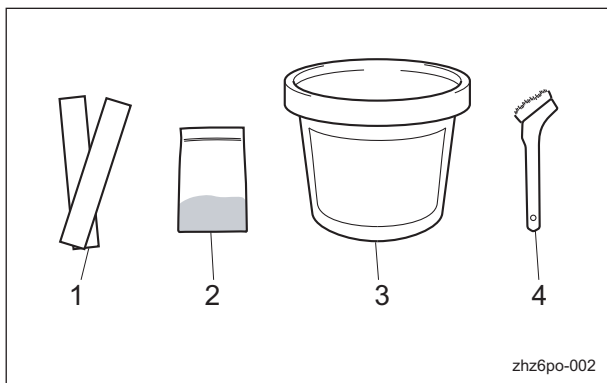

Back Lapping_001

1	Newspaper
2	Back lapping powder
3	Gel compound
4	Brush

Note:

The mixture ratio of the abrasive is 1 part back lapping powder (#150 - #200) : 3-4 parts oil.

Caution

When handling the reel cutter or bed knife, wear gloves to protect your hands. Pay attention not to let the reel cutter catch your gloves, etc. Otherwise, your hand or fingers may be injured.

Important

Check sharpness with the blade engagement condition after cutting.

2. Raise all mower units.
3. Stop the engine, and then apply the parking brake.
4. Set the reel rotation/stop switching lever to the "Stop" position.

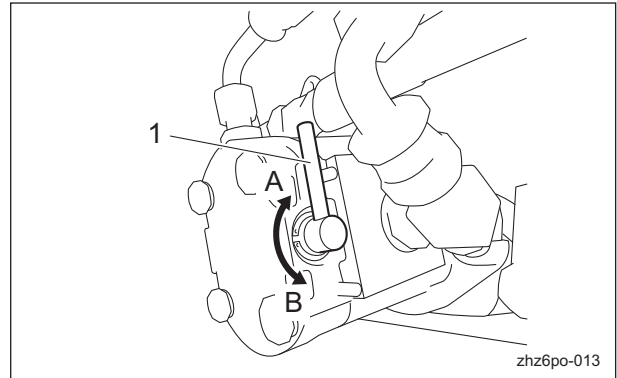

Back Lapping_002

1	Reel rotation/stop switching lever
A	Rotate
B	Stop

5. Insert two or three strips of newspaper into the space between the reel cutter and the bed knife at an angle of 90 degrees. Then, rotate the reel cutter counterclockwise (as seen from the left side of the mower unit) by hand to check the sharpness.
6. Check the sharpness along the entire reel cutter surface (around 3 to 4 positions).
7. Check the sharpness and mark areas that are sharp with chalk or similar.
8. Set the reel rotation/stop switching lever of the hydraulic motors for the mower units that require back lapping to the "Rotation" position.
For mower units that do not require back lapping, set the lever to the "Stop" position.
9. Start the engine.
Note:
The engine will not start if the reel is set to rotate on the main vehicle side.
10. Lower all mower units to the ground.
11. Set the reel rotation to "Back lapping rotation (reverse)."
12. Run the engine at low speed.
13. Rotate the reel cutter for back lapping.

14. Adjust the rotation speed of the reel cutter with the reel rotation/stop switching lever.
15. Apply abrasive to a brush, and apply evenly to areas of the reel cutter that are sharp using the chalk markings as a guide. (Never apply it to areas that have poor sharpness.)
16. Keep the engine rotating for a while until there is no contact noise, and then stop the rotation of the reel cutter.
17. Raise all mower units.
18. Stop the engine.
19. Wash off the abrasive applied to the reel cutter or wipe it clean with waste cloth or similar, and check the sharpness.
20. Repeat the procedures from 4 through 19 for back lapping until the entire reel cutter surface (around 3 to 4 positions) is even.
21. Lower all mower units to the ground.
22. Next, apply abrasive across the entire reel cutter blade edge for final back lapping.
23. Stop the reel rotation.
24. Stop the engine.
25. Carefully wash off all the remaining abrasive completely.
26. Set the reel rotation to "Mowing rotation (normal)."
27. Return the reel rotation/stop switching lever to the "Stop" position.
28. Adjust the blade engagement while checking the sharpness.

Sharpening of Reel Cutter (Cutting Cylinder)

The sharpening of the reel cutter (cutting cylinder) consists in maintaining its roundness and creating a relief (second edge face). This work should be performed if the sharpness cannot be restored, even after back lapping, or if the relief (second edge face) has worn away.

Sharpen the reel cutter (cutting cylinder) when the sharpness cannot be restored, even after back lapping, or when the relief (second edge face) has worn away, there is full contact or back lapping takes too much time.

In addition, if the reel cutter (cutting cylinder) becomes worn and its shape conical, perform cylindrical grinding to return it to a cylindrical shape.

For sharpening the reel cutter (cutting cylinder), contact your dealer or Baroness unless you have a grinding machine.

⚠ Caution

Both the reel cutter (cutting cylinder) and the bed knife (bottom blade) are edged tools. Handle them carefully, since they could cut your hands and feet.

⚠ Caution

Wear gloves when touching edged tools to avoid cutting your hands.

The criteria for sharpening the reel cutter (cutting cylinder) are described below. However, these criteria are only a reference and do not guarantee performance of a reel cutter (cutting cylinder).

1. If the outer diameter of the reel cutter (cutting cylinder) after sharpening is more than the usage limit, the reel cutter (cutting cylinder) can be sharpened.

New		Usage limit	
Dimension A (Outer diameter of reel cutter (cutting cylinder))	Dimension B (Distance from blade edge to outer edge of reel cutter (cutting cylinder) shaft)	Dimension A (Outer diameter of reel cutter (cutting cylinder))	Dimension B (Distance from blade edge to outer edge of reel cutter (cutting cylinder) shaft)
163 mm (6.42 in)	68.8 mm (2.71 in)	143 mm (5.63 in)	58.8 mm (2.31 in)

Note:

The outer diameter of the reel cutter (cutting cylinder) shaft is 25.4 mm (1.00 in).

Maintenance

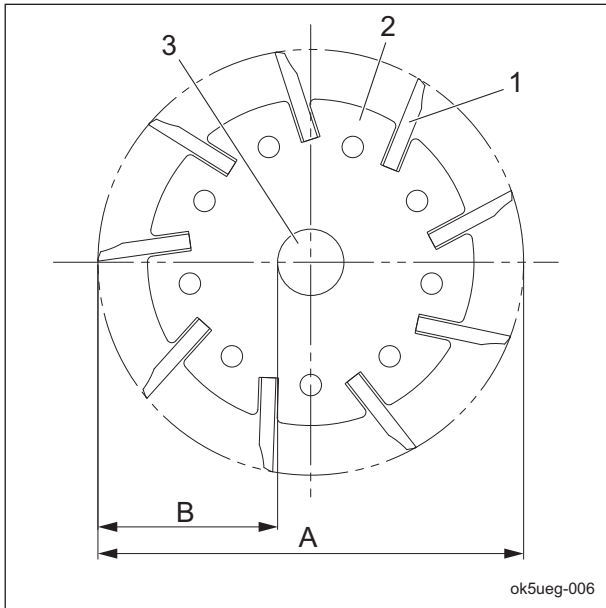

Sharpening of Reel Cutter (Cutting Cylinder)_001

1	Reel cutter (cutting cylinder) blade
2	Reel cutter (cutting cylinder) disc
3	Reel cutter (cutting cylinder) shaft
A	Outer diameter of reel cutter (cutting cylinder)
B	Distance from blade edge to outer edge of reel cutter (cutting cylinder) shaft

2. Sharpening is necessary when the reel cutter (cutting cylinder) reaches a condition described below.

[1] When the sharpening width (length of contacting surface of bed knife (bottom blade)) for the outer diameter of the reel cutter (cutting cylinder) is greater than the usage limit.

Outer diameter of reel cutter (cutting cylinder) (new part)	Usage limit of sharpening width for outer diameter of reel cutter (cutting cylinder)
163 mm (6.42 in)	3.0 mm (0.12 in) (factory-recommended)

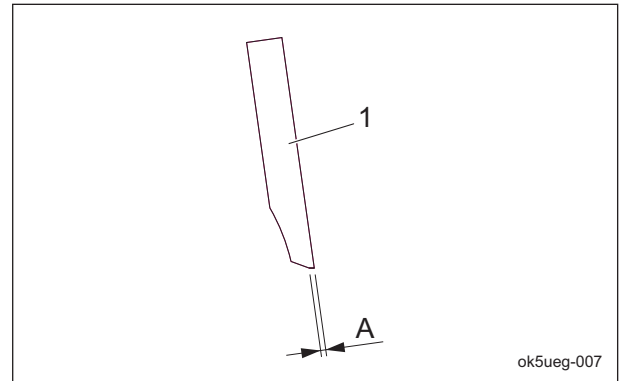

Sharpening of Reel Cutter (Cutting Cylinder)_002

1	Reel cutter (cutting cylinder) blade
A	Sharpening width for outer diameter of reel cutter (cutting cylinder)

[2] When the edges become blunt or the blade edge cannot be formed with back lapping

[3] When the reel cutter (cutting cylinder) becomes worn and its shape conical, or when blade engagement adjustment cannot be performed

Replacement of Reel Cutter (Cutting Cylinder)

⚠ Caution

Both the reel cutter (cutting cylinder) and the bed knife (bottom blade) are edged tools. Handle them carefully, since they could cut your hands and feet.

⚠ Caution

Wear gloves when touching edged tools to avoid cutting your hands.

The criteria for replacing the reel cutter (cutting cylinder) are described below.

However, these criteria are only a reference and do not guarantee performance like that of a new reel cutter (cutting cylinder).

1. When the outer diameter of the reel cutter (cutting cylinder) is less than the usage limit

New		Usage limit	
Dimension A (Outer diameter of reel cutter (cutting cylinder))	Dimension B (Distance from blade edge to outer edge of reel cutter (cutting cylinder) shaft)	Dimension A (Outer diameter of reel cutter (cutting cylinder))	Dimension B (Distance from blade edge to outer edge of reel cutter (cutting cylinder) shaft)
163 mm (6.42 in)	68.8 mm (2.71 in)	143 mm (5.63 in)	58.8 mm (2.31 in)

Note:
The outer diameter of the reel cutter (cutting cylinder) shaft is 25.4 mm (1.00 in).

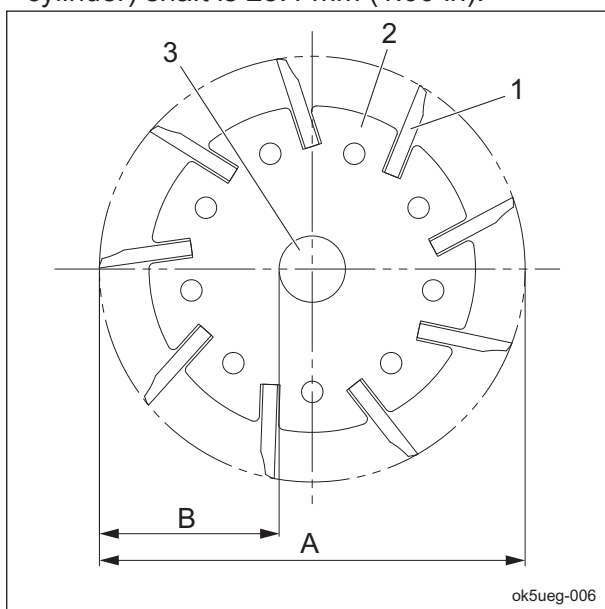

Replacement of Reel Cutter (Cutting Cylinder)_001

1	Reel cutter (cutting cylinder) blade
2	Reel cutter (cutting cylinder) disc
3	Reel cutter (cutting cylinder) shaft
A	Outer diameter of reel cutter (cutting cylinder)
B	Distance from blade edge to outer edge of reel cutter (cutting cylinder) shaft

Replacement of Bed Knife (Bottom Blade)

⚠ Caution

Both the reel cutter (cutting cylinder) and the bed knife (bottom blade) are edged tools. Handle them carefully, since they could cut your hands and feet.

⚠ Caution

Wear gloves when touching edged tools to avoid cutting your hands.

The criteria for replacing the bed knife (bottom blade) are described below.

1. When the reel cutter (cutting cylinder) is ground
2. When the reel cutter (cutting cylinder) is replaced
3. When the bed knife (bottom blade) is worn High-speed-steel-tipped blade
Replace the bed knife (bottom blade) before it no longer has a tip.

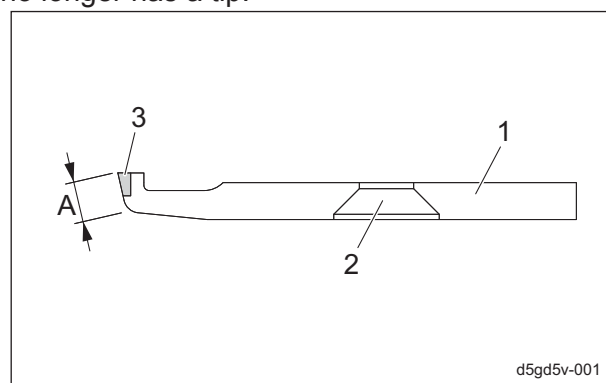

Replacement of Bed Knife (Bottom Blade)_001

1	Bed knife (bottom blade)
2	Mounting hole
3	Tip
A	Front face

Maintenance

Adjustment of Belt Tension

1	Tension pulley adjustment bolt
2	Belt

Warning

Be sure to stop the engine before adjusting the belts.

Caution

If you have removed covers, etc., be sure to securely install them in their original positions. If covers, etc., remain removed, the operator may come in contact with rotating parts or belts, or foreign objects may fly off, possibly resulting in injuries.

Important

For the specified value of belt tension, refer to Adjusted Values.
After rotating the belt several times, check that it has the specified tension.

The belt tension is appropriate when the belt slacks by approximately 5.0 to 6.0 mm (0.197 to 0.236 in) when you apply a force of 10.0 N (1.0 kgf) with your finger to the belt at the middle point between the pulleys.

If the belt becomes slack due to frequent use, it may jump or slip.
In addition, if it is overtightened, it may wear prematurely.
If necessary, adjust it, and always check the belt for appropriate tension.

CR Brush Drive Belt

Note:

Depending on the specifications, this function may not be available.

1. Remove the belt cover.
2. Check the belt tension.
3. If the belt tension is inappropriate, adjust the belt tension with the tension pulley adjustment bolt.

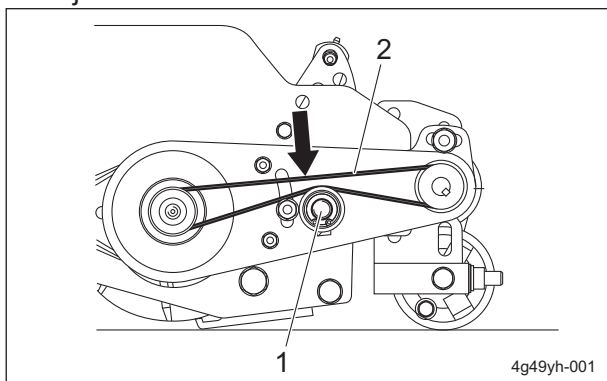

CR Brush Drive Belt_001

BARONESS[®]
Quality on Demand

 **KYOEISHA CO., LTD.**
Head Office 1-26, Miyuki-cho, Toyokawa-city, Tel :+81-533-84-1390
Aichi-pref, 442-8530 JAPAN Fax:+81-533-84-1220