

LM531

5-Unit Reel Mower

Owner's Operating Manual

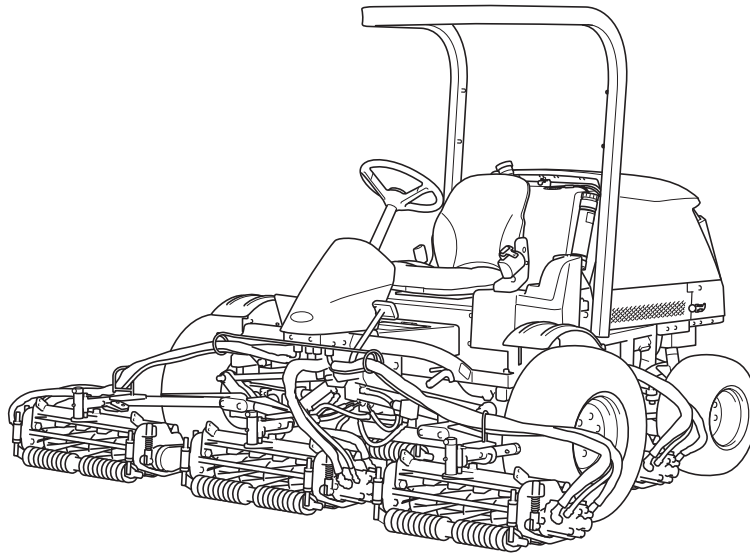

Serial No. LM531 : 10041-

"Required reading"
Read this manual before using the machine.

BARONESS[®]
Quality on Demand

Original Instructions Ver.1.3

Regulations

California Proposition 65

(For California, USA)

WARNING:

Operating, servicing and maintaining a passenger vehicle or off-road vehicle can expose you to chemicals including engine exhaust, carbon monoxide, phthalates, and lead, which are known to the State of California to cause cancer and birth defects or other reproductive harm. To minimize exposure, avoid breathing exhaust, do not idle the engine except as necessary, service your vehicle in a well-ventilated area and wear gloves or wash your hands frequently when servicing your vehicle. For more information go to www.P65Warnings.ca.gov/passenger-vehicle.

318yi8-005

California Proposition 65_001

California Spark Arrester

(For California, USA)

Warning

Operation of this equipment may create sparks that can start fires around dry vegetation.

A spark arrester may be required.

The operator should contact local fire agencies for laws or regulations relating to fire prevention requirements.

The engine of this machine is not equipped with a spark arrester.

In some areas there are local, state, or federal regulations requiring that a spark arrester be used on the engine of this machine.

The recommended spark arrester for this machine is Part No.49028N Spark Arrester made by Nelson Global Products.

Thank you for purchasing the Baroness product.
This manual describes the proper handling,
adjustment, and inspection of your product.
We hope you will use the product safely, and take
advantage of its best performance.

Keeping the Owner's Operating Manual

Keep this Manual in the box on the left side of
the fuel tank.

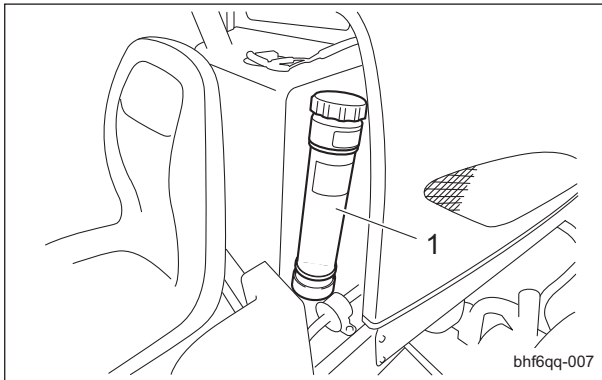

Keeping the Owner's Operating Manual_001

1	Box
---	-----

Introduction

Read this manual carefully to ensure that you thoroughly understand how to properly operate and maintain the product, and to avoid causing injury to yourself or others.

The operator is responsible for operating the product properly and safely.

Maintenance service for this machine should be performed by a mechanic with expertise.

If you have any questions concerning maintenance or genuine parts, please contact a Baroness dealer or Kyoisha.

When making inquiries about the product, please specify the product's model designation and serial number.

When loaning or transferring the product, please also provide this manual together with the product.

Kyoisha Co., Ltd.

Warning Symbols

This manual uses the following warning symbols for handling precautions that are important for your safety.



696cq5-001

Warning symbol

This symbol indicates the articles regarding “Danger,” “Warning,” or “Caution.”

Those articles describe important safety precautions and so read them carefully to understand completely before operating the machine.

Failure to adequately follow these safety precautions may cause an accident.

Danger

This symbol indicates that serious injury or death will occur if the warning is ignored.

Warning

This symbol indicates that serious injury or death may occur if the warning is ignored.

Caution

This symbol indicates that injury or damage to property may occur if the warning is ignored.

Important

This symbol indicates precautions on the mechanism of the machine.

Precautionary Statement

 Caution

The information described in this manual is subject to change for improvement without prior notice.

When replacing parts, be sure to use genuine Baroness parts or parts designated by Kyoisha.

Note that the Baroness product warranty may not apply to defects caused by the use of parts from other companies.

Prior to use, carefully read the following manuals to thoroughly understand the contents for safe and correct operation.

- Baroness Owner's Operating Manual
- The Engine's Owner's Manual
- The Battery's Owner's Manual

Purpose

This product is intended for cutting turf grass at golf courses.

Do not use this product in any way other than its intended purpose, and do not modify this product.

Operating this product for other purposes and modifying it may be very dangerous and may cause damage to the product.

In addition, this product is not authorized for operation as a special motor vehicle. Do not operate it on public roads.

LM531

Introduction

Safety	Page 1-1
Safe Operating Practices	Page 1-2
Disposal	Page 2-1
Recycle and Waste Disposal	Page 2-2
Product Overview	Page 3-1
Specifications	Page 3-2
Names of Each Section	Page 3-4
Regulation Decals	Page 3-5
Safety Signs and Instruction Signs	Page 3-9
Handling Instructions	Page 4-1
Inspections	Page 4-2
Tightening Torques	Page 4-14
Adjustment before Work	Page 4-18
Procedure to Start/Stop Engine	Page 4-20
Operation Method	Page 4-22
Instruments	Page 4-33
Move	Page 4-35
Cutting Work	Page 4-36
Transporting	Page 4-37
Storage	Page 4-38
Maintenance	Page 5-1
Maintenance Precautions	Page 5-2
Maintenance Schedule	Page 5-3
Jacking Up The Machine	Page 5-8
Greasing	Page 5-9
Lubrication	Page 5-12
Maintenance Work	Page 5-13

LM531

Contents

Safe Operating Practices Page 1-2

Training Page 1-2

Preparation Page 1-2

Operation Page 1-3

Maintenance Page 1-4

Storage Page 1-5

Safety

Failure to adequately follow these safety precautions may cause an accident resulting in injury or death.

Danger

This product is designed to ensure safe operation and has been tested and inspected thoroughly before shipment from the factory. The product is equipped with safety devices to prevent accidents.

However, whether the product demonstrates its original performance level depends on the manner in which it is operated and handled, as well as the manner in which it is managed on a daily basis.

Inappropriate use or management of the product may result in injury or death.

Observe the following safety instructions to ensure safe operation.

Safe Operating Practices

Training

1. Read this manual and other training material carefully.

Be familiar with the controls, safety signs, and the proper use of the equipment.

2. If the operator or mechanic can not read the language used in this manual, it is the owner's responsibility to explain this material to them.

3. All operators and mechanics should seek and obtain professional and practical instruction.

The owner is responsible for training the users.

Such instruction should emphasize:

- [1] The need for care and concentration when working with ride-on machines.

- [2] Control of a ride-on machine sliding on a slope will not be regained by the application of the brake.

The main reasons for loss of control are

- Insufficient wheel grip
- Being driven too fast
- Inadequate braking
- The type of machine is unsuitable for its task
- Lack of awareness of the effect of ground conditions, especially slopes
- Incorrect hitching and load distribution

4. Never allow children or people unfamiliar with these instructions to use or service the machine.

Local regulations may restrict the age of the operator.

5. The owner/user can prevent and is responsible for accidents or injuries occurring to themselves, other people, or property.
6. Keep in mind that the owner, operator, and mechanic are responsible for accidents or hazards occurring to other people or their property.
7. The ROPS is an integral and effective safety device.
Do not remove or alter the ROPS.
8. Replace a damaged ROPS.
Do not repair or alter.
9. You can find additional safety information where needed throughout this manual.
10. Determine the left and right sides of the machine from the normal operating position.

Preparation

1. Evaluate the terrain to determine what accessories and attachments are needed to properly and safely perform the job.
Only use accessories and attachments approved by the manufacturer.
2. While operating, always wear substantial footwear, long trousers, hard hat, safety glasses, mask, and ear protection.
Long hair, loose clothing, or jewelry may get tangled in moving parts.
Do not operate the equipment when barefoot or wearing open sandals.
3. Inspect the area where the equipment is to be used and remove all objects such as rocks, toys and wire which can be thrown by the machine.
4. Keep children out of the operating area and under the watchful care of a responsible adult other than the operator.

5. Exercise care in the handling of fuel.

 Warning

Fuel is highly flammable.
Take the following precautions:

- [1] Store fuel in containers specifically designed for this purpose.
 - [2] Add fuel before starting the engine.
Never remove the cap of the fuel tank or add fuel while the engine is running or when the engine is hot.
 - [3] Refuel outdoors only and do not smoke while refueling.
 - [4] If fuel is spilled, do not attempt to start the engine but move the machine away from the area of spillage and avoid creating any source of ignition until petrol vapours have dissipated;
 - [5] Replace all fuel tanks and container caps securely.
6. Check that operator's presence controls, safety switches and shields are attached and functioning properly.
Do not operate unless they are functioning properly.
 7. If the brake operation is faulty, be sure to adjust or repair them before operating the machine.
 8. Replace faulty mufflers.
 9. On multi-cylinder/multi-reel machines, take care as rotating one cylinder/reel can cause other cylinders/reels to rotate.

Operation

1. Do not operate the machine under the influence of alcohol or drugs.
2. Do not operate the engine in a confined space where dangerous carbon monoxide fumes can collect.
3. Be sure all drives and shift are in neutral and parking brake is engaged before starting engine.
Only start engine from the operator's position.
Use seat belts if provided.
4. Do not change the engine governor settings or overspeed the engine.
Operating the engine at excessive speed may increase the hazard of personal injury.

5. Never operate the machine with damaged guards, shields, or without safety protective devices in place.

Be sure all interlocks are attached, adjusted properly, and functioning properly.

6. Keep hands and feet away from the rotating parts.
7. Do not carry passengers.
8. Never operate while people, especially children, or pets are nearby.
9. Only operate in good light, keeping away from holes and hidden hazards.
10. Do not operate the machine when there is the risk of lightning.
11. Do not stop or start suddenly.
12. Look behind and down before backing up to be sure of a clear path.
13. Slow down and use caution when making turns and crossing roads and sidewalks.
14. Use care when approaching blind corners, shrubs, trees, or other objects that may obscure vision.
15. Do not take your eyes off the road ahead.
Do not operate the machine with no hands.
16. Remember there is no such thing as a safe slope.
Travel on grass slopes requires particular care.
To guard against overturning, follow these instructions.
 - [1] Do not stop or start suddenly when going up or downhill.
 - [2] Engage clutch slowly, always keep machine in gear, especially when traveling downhill.
 - [3] Machine speeds should be kept low on slopes and during turns.
 - [4] Stay alert for humps and hollows and other hidden hazards.
17. Never use the machine on a slope with an angle of gradient that is greater than that specified or in a place where there is a danger of the machine slipping.
18. Use extra care while operating machine with a grass catcher or other attachments.
They can affect the stability of the machine.
19. Disengage drive to the cutting unit(s), when other than operating.

Safety

20. Do the following before leaving the operator's position.
 - [1] Stop on level ground.
 - [2] Disengage the all drives.
 - [3] Set the parking brake.
 - [4] Stop the engine.
 - [5] Remove the ignition key.
 21. Stop the engine in the following conditions.
 - [1] Before refuelling.
 - [2] Before removing the grass catcher.
 - [3] Before making height or depth adjustment unless adjustment can be made from the operator's position.
 - [4] Before clearing blockages.
 - [5] Before checking, cleaning or working on the machine.
 - [6] After striking a foreign object or if an abnormal vibration occurs.
Inspect the machine for damage and make repairs before restarting and operating the equipment.
 22. Reduce the throttle setting during engine run-out.
 23. Do not direct discharge material toward anyone.
Avoid discharging material against a wall or obstruction.
Material may ricochet back toward the operator.
 24. Take care when loading or unloading the machine into a trailer or a truck.
Load or unload the machine in a flat and safe place.
Before loading or unloading, set the parking brake on the truck or trailer, stop the engine, and chock the wheels.
When transporting the machine on a truck or a trailer, set the parking brake, stop the engine, and fasten the machine to the truck with a rope or other suitable restraining device that has sufficient strength.
When using a running board, select one with sufficient strength, length, and width and that will not cause the machine to slip.
 25. Close the fuel valve before transporting the machine.
2. Implement the following work before adjusting, cleaning or repairing.
 - [1] Stop the machine on level ground.
 - [2] Disengage drive to the cutting unit(s).
 - [3] Lower the cutting unit(s) and attachment(s) if installed.
 - [4] Set the parking brake.
 - [5] Stop the engine.
 - [6] Remove the ignition key.
 - [7] Wait for all movement to stop.
 3. Allow the engine/muffler to cool before checking/maintenance.
 4. To reduce the fire hazard, keep hot parts such as the engine and silencer/muffler, battery compartment and fuel storage area free of grass, leaves, or excessive grease. Clean up oil or fuel spillage.
 5. Appropriately manage and correctly use the tools necessary for servicing or adjusting the machine.
 6. Disconnect battery before making any repairs.
Disconnect the negative terminal first and the positive last.
Reconnect positive first and negative last.
 7. Use jack stands to support components when required.
 8. Keep hands and feet away from moving parts.
If possible, do not make adjustments with the engine running.
 9. Make sure that parts such as wires are not touching each other and that their covers have not come off.
 10. Keep all parts in good working condition and all hardware tightened.
Replace all worn or damaged decals.
 11. Keep all nuts, bolts and screws tight to be sure the equipment is in safe working condition.
 12. Carefully release pressure from components with stored energy.
 13. Be sure to depressurize the hydraulic system before performing maintenance operations on it such as removing hydraulic equipment.
 14. Check whether line connectors in the hydraulic system are properly tightened.
Before applying hydraulic pressure, check the connections of the hydraulic pressure lines and the condition of the hoses.

Maintenance

1. Never allow untrained personnel to service machine.

15. When checking the hydraulic circuit for pinhole leaks or oil leakage from nozzles, do not use your hands.
Use items such as paper or corrugated cardboard to find leakage points.
Be extremely careful with high-pressure oil as it may pierce your skin, resulting in an injury.
If fluid is injected into the skin it must be surgically removed within a few hours by a doctor familiar with this form of injury or gangrene may result.
 16. Use care when checking the cylinders/reels and bed knives.
Wear gloves and use caution when servicing them.
 17. Be careful during adjustment of the machine to prevent entrapment of the fingers between moving blades and fixed parts of the machine.
 18. On multi-cylinder/multi-reel machines, take care as rotating one cylinder/reel can cause other cylinders/reels to rotate.
 19. Check the grass catcher frequently for wear or deterioration.
 20. Charge batteries in an open well ventilated area, away from spark and flames.
Unplug charger before connecting or disconnecting from battery.
Wear protective clothing and use insulated tools.
 21. If the fuel tank has to be drained, do this outdoors.
7. Swallowing engine coolant can cause injury or death; keep out of reach from children and pets.

Storage

1. When machine is to be parked, stored, or left unattended, lower the cutting unit(s) and attachment(s) if installed unless a positive mechanical lock is provided.
2. Allow the engine to cool before storing in any enclosure.
3. Only cover the machine with a sheet after hot parts have sufficiently cooled down.
4. Never store the equipment with fuel in the tank inside a building where fumes may reach an open flame or spark.
5. If the engine is provided with a shut-off valve, shut off valve while storing or transporting.
6. Do not store fuel near flames.

Recycle and Waste Disposal Page 2-2

About RecyclePage 2-2

About Waste Disposal Page 2-2



Disposal

Recycle and Waste Disposal

About Recycle

Recycling battery etc. is recommended for environmental conservation and economical use of resources.

It may be required by local laws.

About Waste Disposal

Make sure that waste generated when servicing or repairing the machine is disposed of in accordance with local regulations. (e.g. waste oil, antifreeze, rubber products, and wires etc.)

Specifications Page 3-2

SpecificationsPage 3-2

Mower UnitsPage 3-3

Sound Pressure Level Page 3-3

Sound Power Level Page 3-3

Vibration LevelPage 3-3

Carbon Dioxide (CO₂) Emissions
MeasurementPage 3-3**Names of Each Section Page 3-4****Regulation DecalsPage 3-5**

Positions of Regulation Decals Page 3-5

Description of Regulation Decals Page 3-5

Safety Signs and Instruction Signs Page 3-9About Safety Signs and Instruction
SignsPage 3-9Positions of Safety Decals and
Instruction Decals Page 3-9Description of Safety Decals and
Instruction Decals Page 3-10

Product Overview

Specifications

Specifications

Model		LM531	
Dimensions	Total length		119.29 in 303 cm
	Total width	During operation	116.5 in 296 cm
		During transport	86.6 in 220 cm
	Total height	Steering wheel	52.4 in 133 cm
Weight	Machine (empty fuel tank)	with Slight lift and ROPS	2755.7 lb 1,250 kg
Minimum turning radius		110.2 in 280 cm	
Engine	Model		Kubota D1105-E4B (Diesel)
	Type		Vertical Water-cooled 4-cycle diesel engine
	Total displacement		68.52 cu.in. 1,123 cm ³ (1.123 L)
	Maximum output		18.5 kW (25.2 PS)/3,000 rpm
Fuel tank capacity		Diesel 10.04 U.S.gal. Diesel 38.0 dm ³ (38.0 L)	
Fuel consumption		213 g/PS · h (rated output) 289 g/kW · h (rated output)	
Engine oil capacity		0.82 U.S.gal. 3.1 dm ³ (3.1 L)	
Coolant volume		1.59 U.S.gal. 6.0 dm ³ (6.0 L)	
Hydraulic tank capacity		9.25 U.S.gal. 35.0 dm ³ (35.0 L)	
Operating width (Mowing width)		99.2 in 252 cm	
Operating height (Mowing height)		0.394 - 2.362 in 10 - 60 mm	
Blades		9	
Drive	Traveling		HST (Full time 4WD)
	Mowing		Hydraulic
Speed (HST)	Forward		0 - 9.63 mph 0 - 15.5 km/h
	Reverse		0 - 4.97 mph 0 - 8.0 km/h
Speed (Mechanical)		-	
Efficiency		4.98 acres/hour (6.22 mph x mowing width x 0.8)	20,160 m ² /h (10.0 km/h x mowing width x 0.8)
Maximum inclination for operation		15 degrees	
Tire size	Front wheel		26.0 x 12.00 - 12
	Rear wheel		20 x 10.00 - 10
Tire pneumatic pressure	Front wheel		20.30 psi 140 kPa (1.4 kgf/cm ²)
	Rear wheel		14.50 psi 100 kPa (1.0 kgf/cm ²)
Battery		75D23L	
Engine plug		-	

The factory default maximum engine rpm is 3,100 rpm.

Mower Units

Baroness mower unit that can fit this machine is the model marked with a circle in the "Attachable unit" column.

LM531

Baroness mower unit	Model		Attachable unit	Remarks
Small diameter mower unit	LH52	22 in	-	
Multi configuration mower unit	LH62	22 in	-	
	LH66	26 in	-	
Standard mower unit	LS62	22 in	○	
	LS66	26 in	-	

Sound Pressure Level

Sound Pressure Level

This machine was confirmed to have a continuous A-weighted sound pressure level of 88 dB by measuring identical machines in accordance with the procedure specified in ISO5395-1:2013.

Sound Power Level

Sound Power Level

This machine was confirmed to have a sound power level of 105dB by measuring identical machines in accordance with the procedure specified in ISO5395-1:2013.

Vibration Level

Hand-Arm Vibration

This machine was confirmed not to exceed a vibration level of 2.5 m/s² to hands and arms by measuring identical machines in accordance with the procedure specified in ISO 5395-1:2013.

Whole Body Vibration

This machine was confirmed not to exceed a vibration level of 0.5 m/s² to the whole body by measuring identical machines in accordance with the procedure specified in ISO 5395-1:2013.

Carbon Dioxide (CO₂) Emissions Measurement

For CO₂ emissions measurement on the engine of this machine, refer to the engine's owner's manual.

Product Overview

Names of Each Section

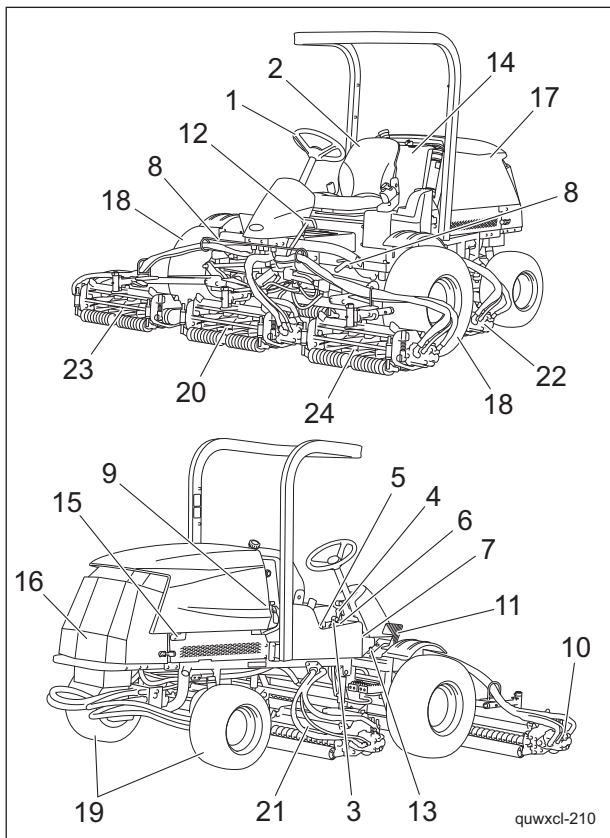

Names of Each Section_001

1	Steering wheel
2	Seat
3	Throttle lever
4	Mower unit up/down lever
5	Reel rotation switch
6	Light switch
7	Stop valve
8	Mower lock lever (Latch)
9	Reel reverse switch
10	Reel rotation/stop switching lever
11	Traveling pedal
12	Brake pedal
13	Parking brake lock lever
14	Fuel tank
15	Muffler
16	Battery
17	Hood
18	Front tire
19	Rear tire
20	Mower unit #1
21	Mower unit #2
22	Mower unit #3
23	Mower unit #4
24	Mower unit #5

Regulation Decals

Positions of Regulation Decals

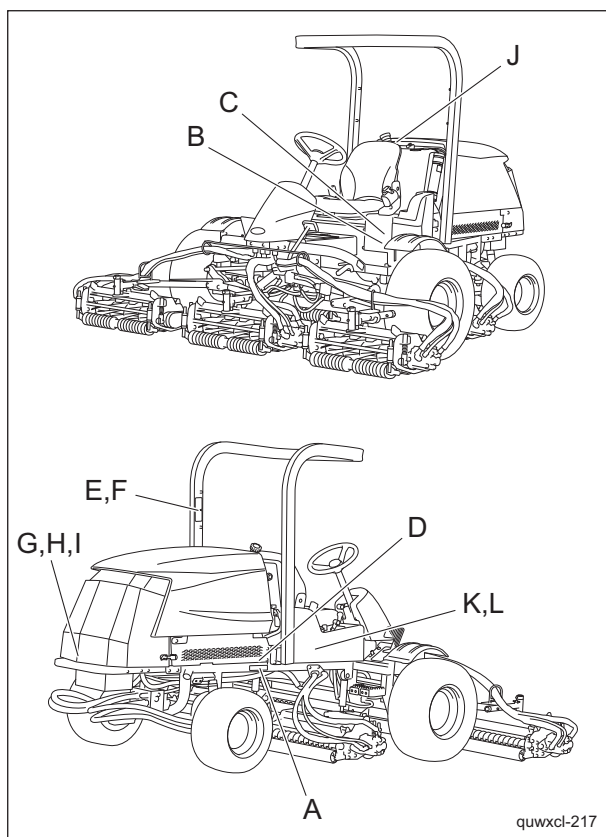

Positions of Regulation Decals_001

A	Serial number plate
B	Specification decal
C	Noise emission decal
D	Year of manufacture decal
E	ROPS compliance decal
F	ROPS caution decal
G	Battery capacity decal
H	Recycle decal
I	Battery danger decal
J	Diesel instruction decal
K	California Proposition 65 decal (riding type)
L	Spark arrester warning decal

Description of Regulation Decals

Serial Number Plate

The serial number plate indicates the model and serial number of the machine.

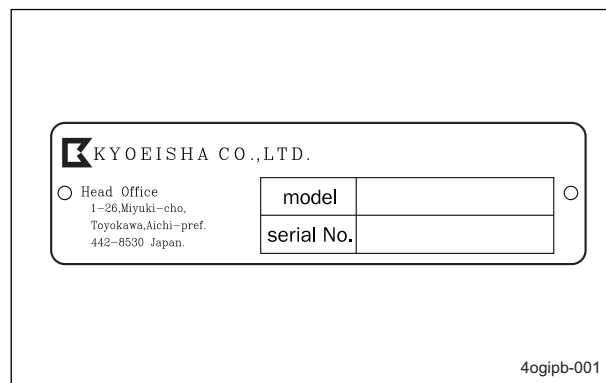

Serial Number Plate_001

Specification Decal

(For Europe)
 CE mark indicates that the machine sold in the EU nations complies with the EU requirements.
 The Specification decal indicates the CE marking, model, and weight, etc.

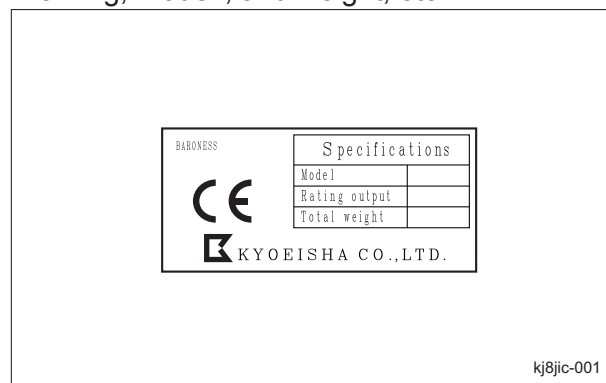

Specification Decal_001

Product Overview

Noise Emission Decal

(For Europe)

The noise emission decal indicates the sound power level determined by measuring identical machines in accordance with the procedure specified in the EC directives.

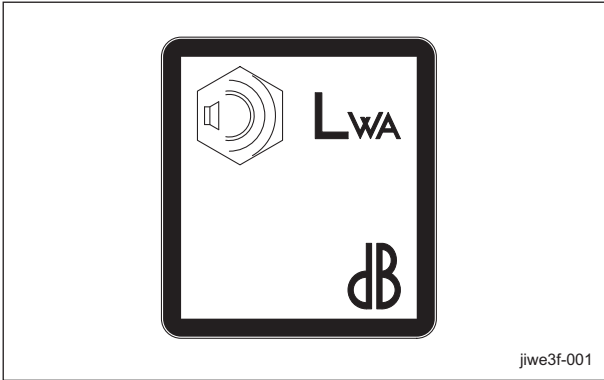

Noise Emission Decal_001

ROPS Caution Decal

ROPS caution decal describes the following caution messages.

- Replace damaged ROPS.
- Do not repair or revise.



ROPS Caution Decal_001

Year of Manufacture Decal

(For Europe)

The year of manufacture decal indicates the year when this machine was manufactured.

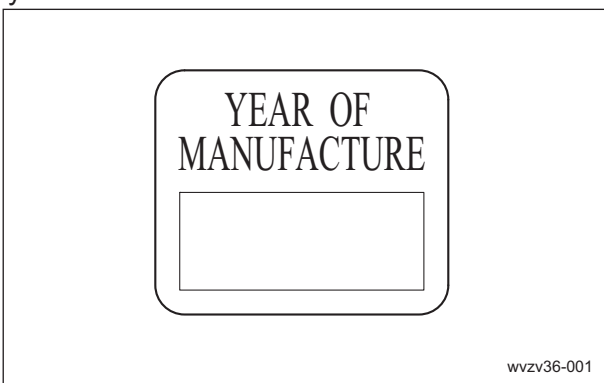

Year of Manufacture Decal_001

Battery Capacity Decal

(For Europe)

The battery capacity decal indicates the capacity by 20HR and CCA.

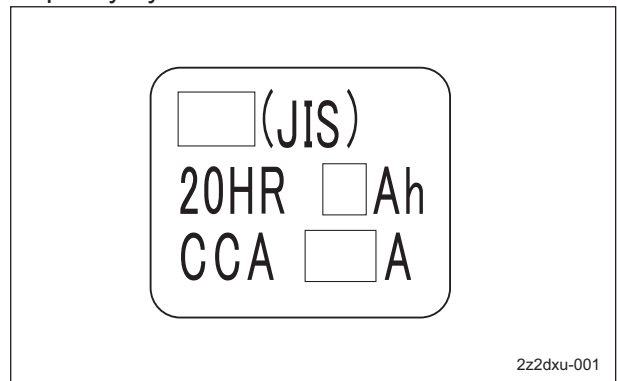

Battery Capacity Decal_001

ROPS Compliance Decal

The ROPS compliance decal indicates the manufacturer, model, etc., in accordance with International Standard ISO 21299:2009.

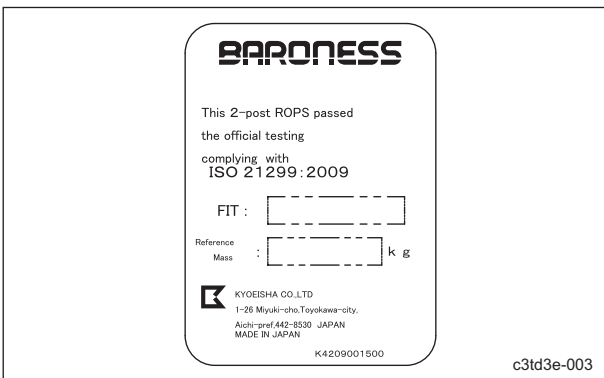

ROPS Compliance Decal_001

Product Overview

Recycle Decal

Recycle Decal illustrates Recycle Mark in accordance with local regulation.
(For Europe)

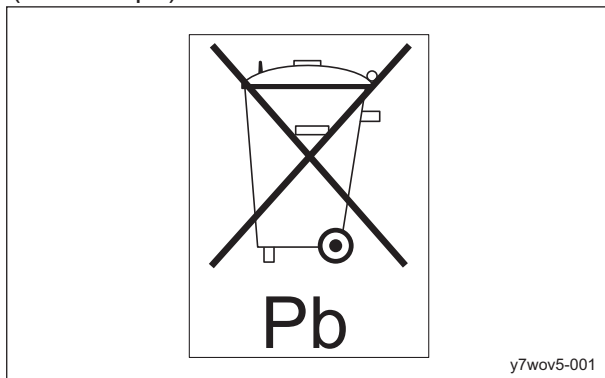

Recycle Decal_001

(For USA)



Recycle Decal_002

Battery Danger Decal

(For USA)
Battery Danger Decal describes handling precautions for battery.

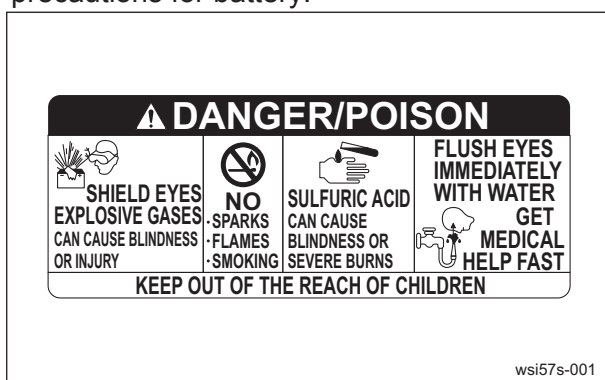

Battery Danger Decal_001

Indicating Diesel Fuel Decal

(for USA)
It indicates the fuel to be used.
Use low sulfur or ultra-low sulfur diesel fuel (sulfur-free diesel fuel).

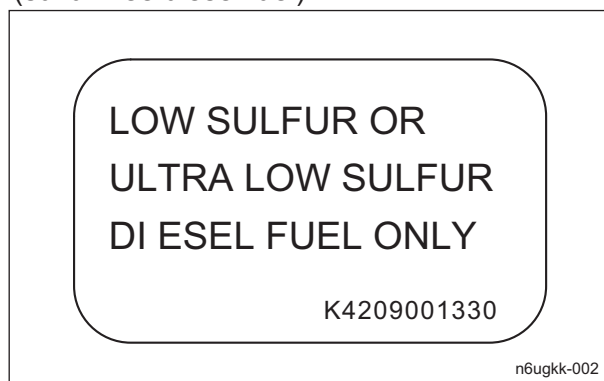

Indicating Diesel Fuel Decal_001

California Proposition 65 Decal (Riding Type)

(For the State of California, USA)
California Proposition 65 decal describes the warning messages as required by California Proposition 65.

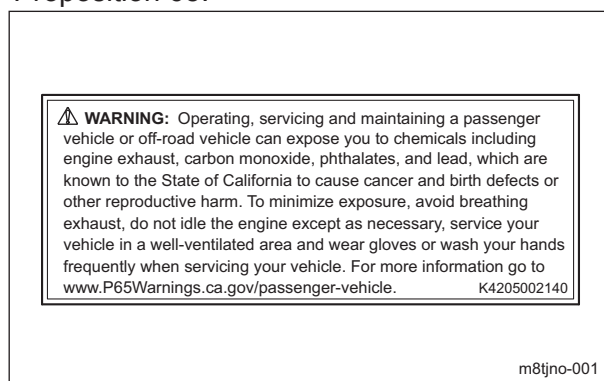

California Proposition 65 Decal (Riding Type)_001

Product Overview

Spark Arrester Warning Decal

(For the State of California, USA)

Spark arrester warning decal describes the warning messages as required by California Public Resources Code.

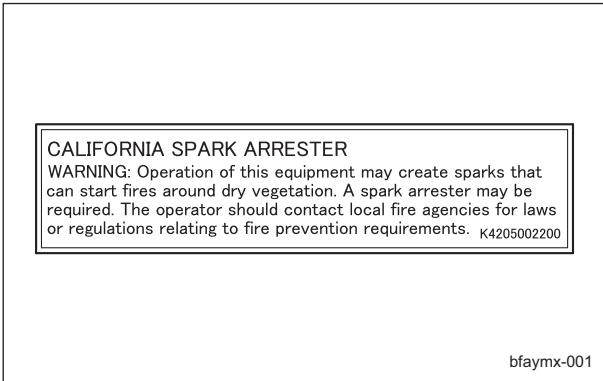

Spark Arrester Warning Decal_001

Safety Signs and Instruction Signs

About Safety Signs and Instruction Signs

Important

Safety decals and instruction decals are attached to this product. Make sure that they are preserved in their entirety. If they are damaged, become dirty, or peel off, replace them with new ones.

Part numbers for decals that need to be replaced are listed in the parts catalog. Order them from a Baroness dealer or Kyoisha.

Positions of Safety Decals and Instruction Decals

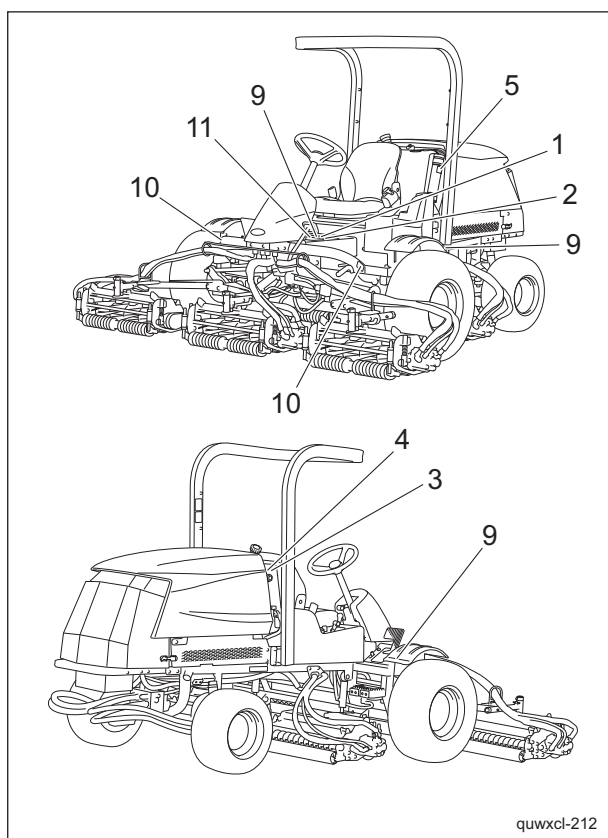

Positions of Safety Decals and Instruction Decals_001

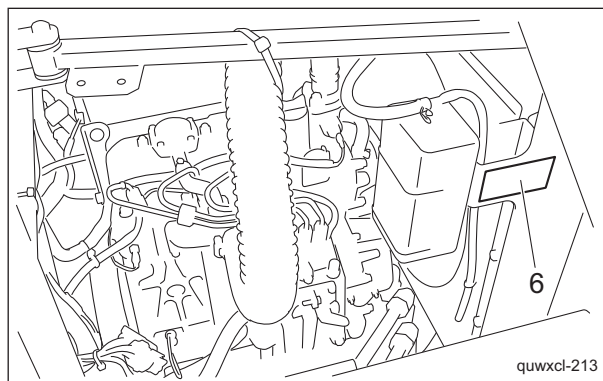

Positions of Safety Decals and Instruction Decals_002

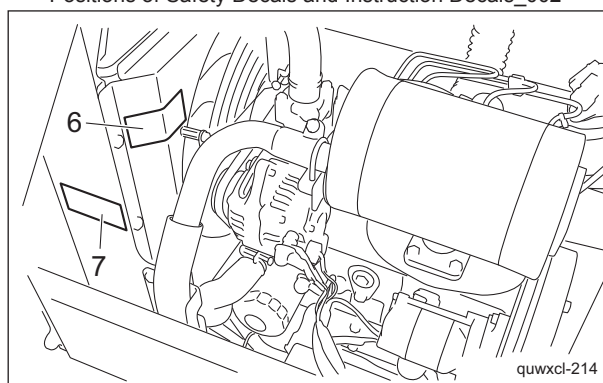

Positions of Safety Decals and Instruction Decals_003

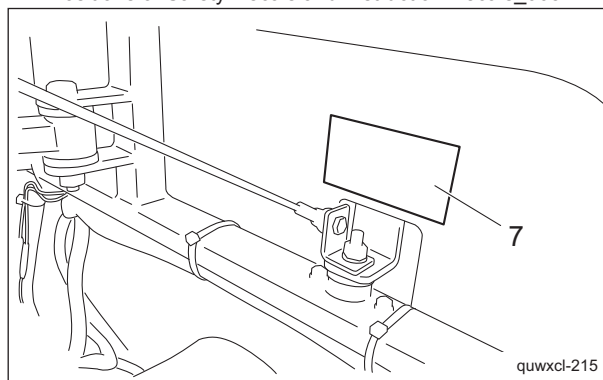

Positions of Safety Decals and Instruction Decals_004

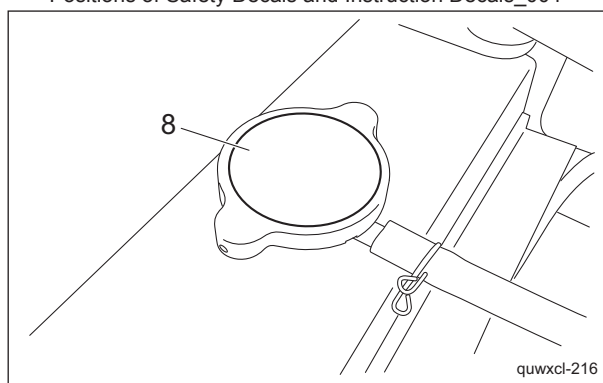

Positions of Safety Decals and Instruction Decals_005

Product Overview

1	Decal for operation 2
2	Hydraulic oil icon
3	Diesel fuel icon
4	Fire prohibited decal
5	Decal on reading owner's operating manual
6	Caution to rotating object decal
7	Caution to hot parts decal
8	Caution for spouting coolant decal
9	DO NOT STEP caution decal
10	Caution for mower lock decal
11	Caution to noise decal

Description of Safety Decals and Instruction Decals

Decal for Operation 2

Decal for operation 2
LM2400-0918Z0

1.

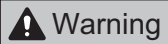

Warning

Read the Owner's Operating Manual.

2.

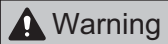

Warning

Apply the parking brake, stop the engine, remove the ignition key, and then leave the machine.

3.



Caution

Flying objects - Be sure that people around the machine keep a safe distance away.

4.

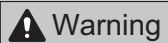

Warning

May cut your hand or leg - Keep hands and feet away from moving parts.

5.

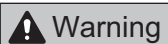

Warning

Be careful of exhaust emissions.

6.



Caution

Rollover - Do not work on slopes of 15 degrees or more.

When you descend a slope, lower the mower units and then drive at low speed.

For ROPS equipped machine, fasten your seatbelt.

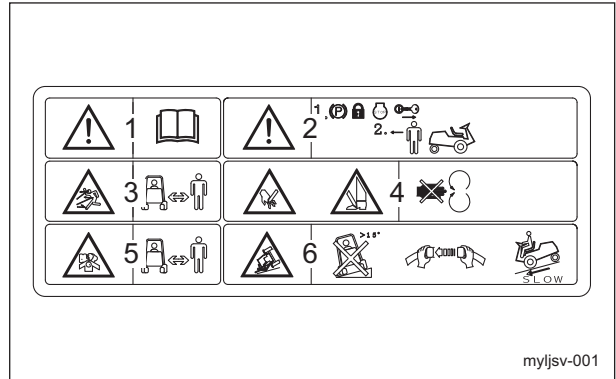

Decal for Operation 2_001

Product Overview

Hydraulic Oil Icon

K4209000980
Hydraulic oil icon
Read the Owner's Operating Manual.

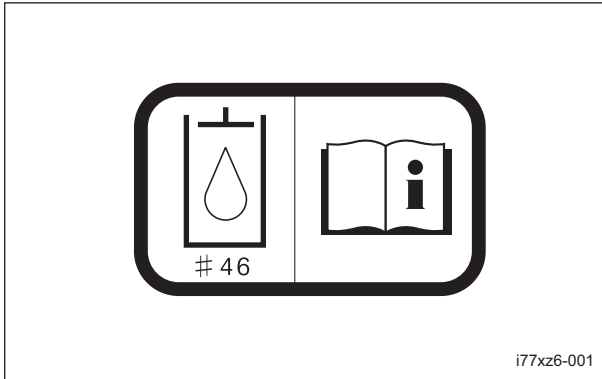

Hydraulic Oil Icon_001

Diesel Fuel Icon

K4209001000
Diesel fuel icon
Use diesel fuel.

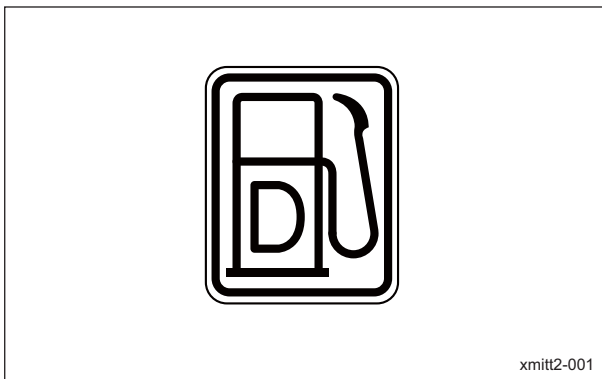

Diesel Fuel Icon_001

Fire Prohibited Decal

K4205001940
Decal, fire prohibited

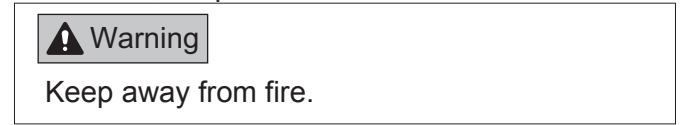

Fire Prohibited Decal_001

Decal on Reading Owner's Operating Manual

K4205001560
Decal, read Owner's Operating Manual

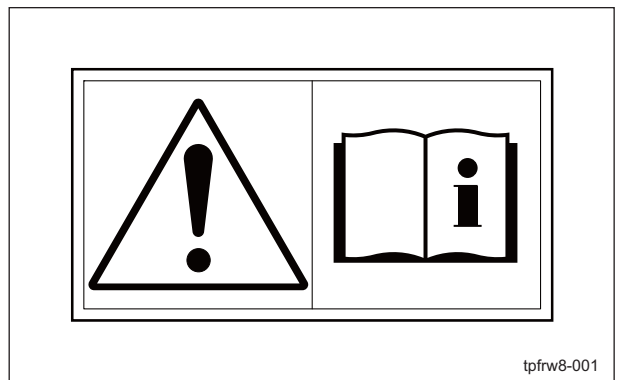
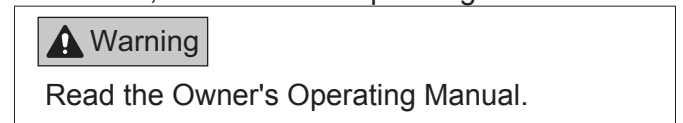

Decal on Reading Owner's Operating Manual_001

Product Overview

Caution to Rotating Object Decal

K4205001530

Decal, caution to rotating object

Warning

Watch for rotating parts - Keep your hands away from the belts while the engine is running.

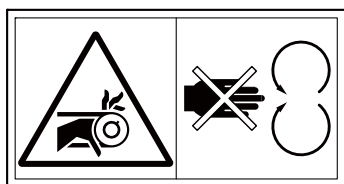

qwsqzx-001

Caution to Rotating Object Decal_001

Caution for Spouting Coolant Decal

K4205001970

Decal, caution for spouting coolant

Caution

Caution for spouting coolant - Do not open while hot.
High temperature - Do not touch. Otherwise, you will get burned.



pwb8d2-001

Caution for Spouting Coolant Decal_001

Caution to Hot Parts Decal

K4205001540

Decal for caution to hot parts

Caution

High temperature - Do not touch. Otherwise, you will get burned.



xekv4l-001

Caution to Hot Parts Decal_001

DO NOT STEP Caution Decal

K4209001340

Decal, caution "DO NOT STEP"

Caution

Do not step.



tg45gw-001

DO NOT STEP Caution Decal_001

Caution for Mower Lock Decal

K4205001900

Decal, caution for mower lock

Lock the mower units when traveling or storing with the mower units #4 and 5 raised.



Caution for Mower Lock Decal_001

Caution to Noise Decal

K4205001330

DECAL, CAUTION TO NOISE



Caution to Noise Decal_001

Product Overview

Handling Instructions

Inspections	Page 4-2	Light Switch	Page 4-27
Radiator Cover	Page 4-2	Throttle Lever	Page 4-27
Radiator	Page 4-2	Mower Unit Up/Down Lever	Page 4-28
Coolant	Page 4-3	Stop Valve	Page 4-28
Oil Cooler	Page 4-4	Mower Lock Lever (Latch)	Page 4-29
Hydraulic Oil	Page 4-4	Reel Rotation Switch	Page 4-29
Hydraulic Hoses	Page 4-6	Reel Reverse Switch	Page 4-30
Air Cleaner	Page 4-6	Reel Rotation/Stop Switching Lever	Page 4-30
Battery	Page 4-7	Traveling Pedal	Page 4-30
Electrical Wiring	Page 4-8	Pedal Stopper	Page 4-31
Tire	Page 4-8	Brake Pedal	Page 4-31
Brake	Page 4-8	Parking Brake Lock Lever	Page 4-31
Belt	Page 4-8	Hood	Page 4-32
Wire	Page 4-8	Underseat Cover	Page 4-32
Safety Device	Page 4-8	Instruments	Page 4-33
Around The Engine	Page 4-9	Instruments on the Operation Panel	Page 4-33
Engine Oil	Page 4-9	Water Temperature Gauge	Page 4-33
Fuel	Page 4-10	Fuel Gauge	Page 4-33
Water Separator	Page 4-11	Pilot Lamps	Page 4-34
Fuel Filter	Page 4-13	Overheat Warning Buzzer	Page 4-34
Oil Leakage	Page 4-13	Hour Meter	Page 4-35
Grass Catcher	Page 4-13	Move	Page 4-35
Tightening Torques	Page 4-14	Traveling Procedure	Page 4-35
Standard Tightening Torques	Page 4-14	Towing the Machine	Page 4-35
Principal Tightening Torques	Page 4-17	Cutting Work	Page 4-36
Adjustment before Work	Page 4-18	Cutting Operation	Page 4-36
Adjustment of Steering Wheel	Page 4-18	Removal/Installation of Grass Catcher	Page 4-37
Adjustment of Seat	Page 4-18	Transporting	Page 4-37
Adjustment of Mower Stopper Pin	Page 4-19	Transporting Procedure	Page 4-37
Procedure to Start/Stop Engine	Page 4-20	Storage	Page 4-38
Start/Stop of Engine	Page 4-20	Before Long-Term Storage	Page 4-38
Safety Mechanisms	Page 4-21		
Warning Mechanisms	Page 4-22		
Operation Method	Page 4-22		
Cautions for when You Leave The Machine	Page 4-22		
Positions of Operation Decals	Page 4-22		
Description of Operation Decals	Page 4-23		

Handling Instructions

Inspections

Inspect the machine according to the maintenance schedule so that you will be able to take advantage of its optimum performance for a long period of time.

Radiator Cover

Inspection of Radiator Cover

1. Make sure that there is no damage to the radiator cover.
2. Make sure that the radiator cover is not contaminated.

Cleaning of Radiator Cover

Important

An unclean radiator cover may cause overheating or damage to the engine. It may also cause malfunction of the hydraulic system.

If the radiator cover has been contaminated with dust, be sure to clean it. Especially after operating the machine in a dusty environment, it is important to remove dust as soon as possible.

1. Unlock the rubber hooks on the left and right sides.

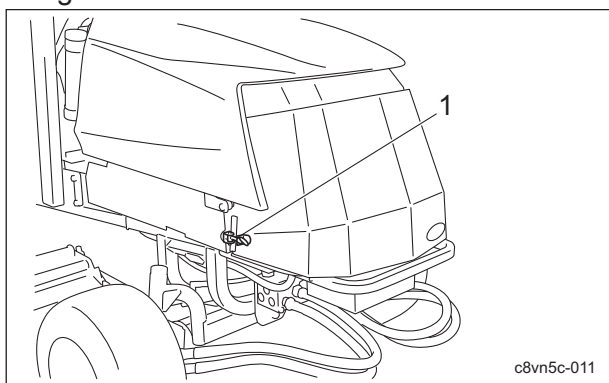

Cleaning of Radiator Cover_001

1	Rubber hook
---	-------------

2. Pull the radiator cover to the back to open it.

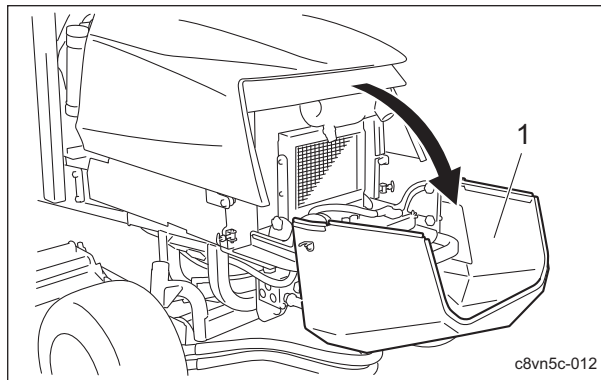

Cleaning of Radiator Cover_002

1	Radiator cover
---	----------------

3. Carefully clean the front and back of the radiator cover with water or compressed air.

Radiator

Inspection of Radiator

1. Make sure that there is no damage to the radiator.
2. Make sure that the radiator is not contaminated.

Cleaning of Radiator

Important

An unclean radiator may cause overheating or damage to the engine. It may also cause malfunction of the hydraulic system.

Important

Do not use solid objects, such as a spatula or screwdriver, or high-pressure water to clean the radiator or oil cooler. Otherwise, special fins or tubes may be damaged, possibly resulting in reduced cooling performance or coolant leakage.

If the radiator has been contaminated with dust, be sure to clean it. After operating the machine in a dusty environment, it is important to remove dust as soon as possible.

1. Open the radiator cover.

Handling Instructions

- Loosen the knobs on the left and right of the oil cooler, and then tilt the oil cooler.

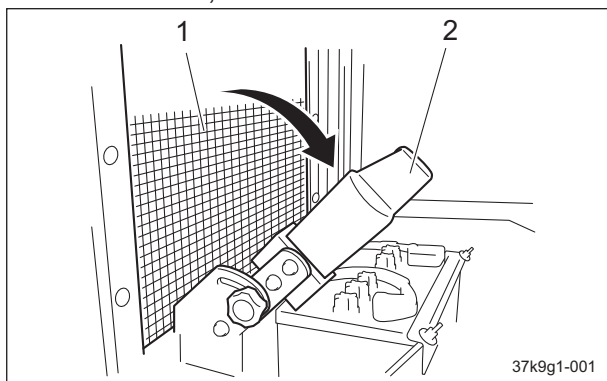

Cleaning of Radiator_001

1	Radiator
2	Oil cooler

- Carefully clean the front and back of the radiator with water or compressed air.

Coolant

Inspection of Coolant

Caution

Do not touch the radiator or coolant during engine operation or immediately after the engine has been turned off. Otherwise, you may get burned.

Caution

Inspection should take place after the engine has well cooled down.

- Make sure that the coolant level in the reserve tank is between "FULL" and "LOW".

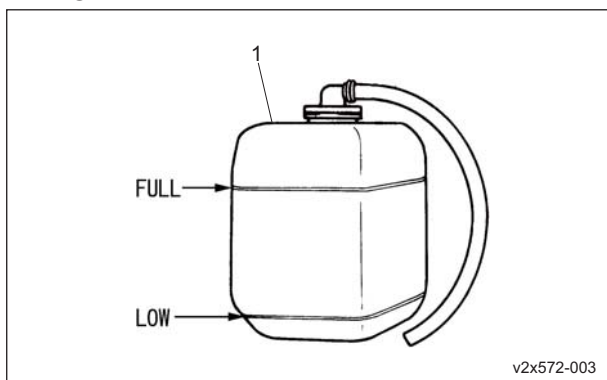

Inspection of Coolant_001

1	Reserve tank
---	--------------

Coolant Supply

Caution

Do not touch the radiator or coolant during engine operation or right after the engine has been turned off. Due to high temperatures, doing so could cause burns.

Caution

Supply coolant after the engine has well cooled down.

Caution

The radiator cap is pressurized. If you remove the radiator cap while the engine is overheated, hot steam will burst out, possibly resulting in burns. Make sure that the water temperature and pressure are reduced, and then grab the cap with a thick cloth and gradually open the cap.

Important

When you supply coolant, be sure to use clean water, such as tap water.

Important

Tightly close the radiator cap. If the cap is loose or incorrectly installed, the engine will be overheated due to water leakage, resulting in engine damage.

- If the coolant level in the reserve tank is lower than the "LOW" mark, open the reserve tank cap and fill the tank with clean water up to the "FULL" mark.

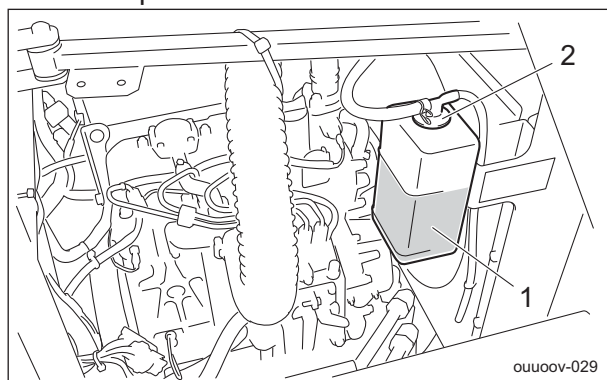

Coolant Supply_001

Handling Instructions

1	Reserve tank
2	Reserve tank cap

2. If no coolant is in the reserve tank, follow the steps below to fill the tank with clean water.

[1] Open the radiator cap, and then supply clean water up to the opening.

[2] Open the reserve tank cap, and then supply clean water up to the "FULL" mark.

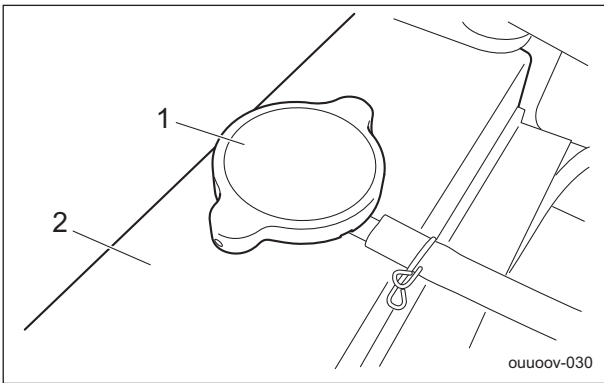

Coolant Supply_002

1	Radiator cap
2	Radiator

Oil Cooler

Inspection of Oil Cooler

1. Make sure that there is no damage to the oil cooler.
2. Make sure that the oil cooler is not contaminated.

Cleaning of Oil Cooler

⚠ Caution

An unclean oil cooler may cause malfunction of the hydraulic system.

Important

Do not use solid objects, such as a spatula or screwdriver, or high-pressure water to clean the radiator or oil cooler. Otherwise, special fins or tubes may be damaged, possibly resulting in reduced cooling performance or coolant leakage.

If the oil cooler has been contaminated with dust, be sure to clean it.

After operating the machine in a dusty environment, it is important to remove dust as soon as possible.

1. Open the radiator cover.
2. Loosen the knobs on the left and right of the oil cooler, and then tilt the oil cooler.

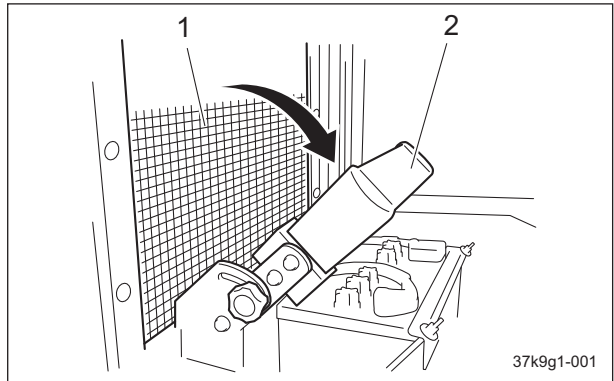

Cleaning of Oil Cooler_001

1	Radiator
2	Oil cooler

3. Carefully clean the front and back of the oil cooler with water or compressed air.

Hydraulic Oil

Inspection of Hydraulic Oil

The oil gauge is on the side of the hydraulic tank.

1. Lower the mower units and maintain that position on a level surface.
2. Make sure that the oil level is at the middle of the oil gauge.

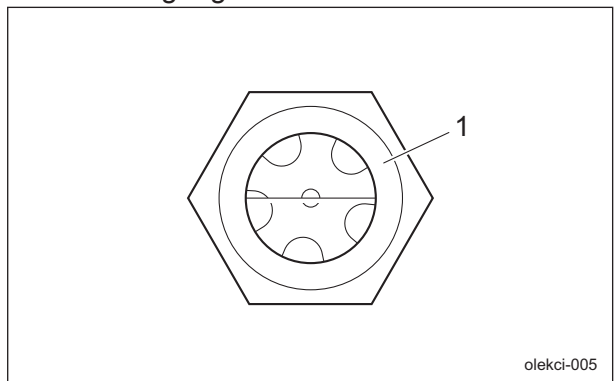

Inspection of Hydraulic Oil_001

1	Oil gauge
---	-----------

3. Check underneath the machine for oil leakage.

Handling Instructions

Hydraulic Oil Supply

Important

Do not mix different types of oil.

Important

Use Shell Tellus S2M46 (or equivalent) as hydraulic oil. In case of an equivalent, consult Characteristics of Hydraulic Oil and use hydraulic oil whose characteristics are superior to those of the specific hydraulic oil. Especially regarding kinematic viscosity and viscosity index, use of hydraulic oil whose figures are less than those of the specified hydraulic oil will cause a malfunction in the hydraulic circuit.

Note:

Characteristics of Hydraulic Oil

Specified Hydraulic Oil		Shell Tellus S2M46
ISO Viscosity Grade		ISO VG46
Density	15 °C (59 °F)	0.873 g/cm ³ (0.0315 lb/in ³)
API Gravity		30.6
Flash Point (Open Cup)		230 °C (446 °F)
Pour Point		-30 °C (-22 °F)
Kinematic	40 °C (104 °F)	46 mm ² /s (46 cSt)
Viscosity	100 °C (212 °F)	7 mm ² /s (7 cSt)
Viscosity Index		109

1. Follow the steps below to supply hydraulic oil if the oil level is low.

[1] Release the catch clip and open the center cover.

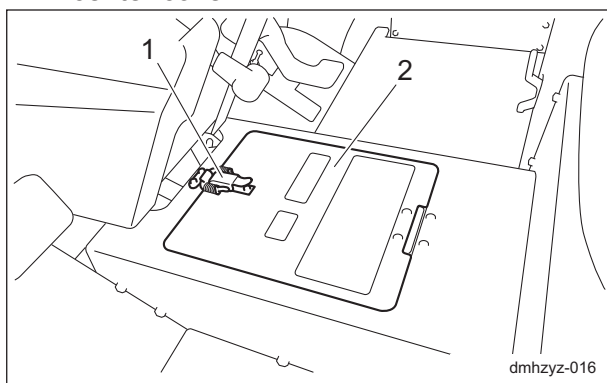

Hydraulic Oil Supply_001

1	Catch clip
2	Center cover

[2] Open the tank cap and pour hydraulic oil from the fill port until the oil level reaches the middle of the oil gauge on the hydraulic tank.

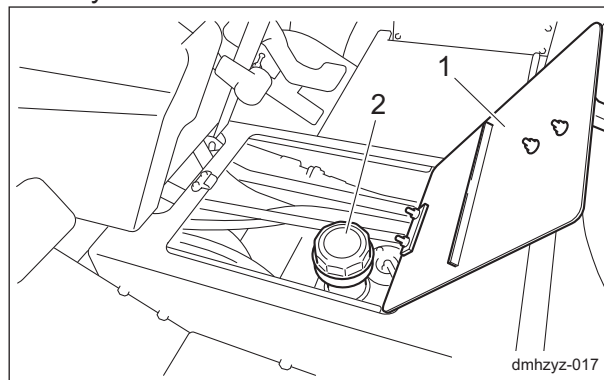

Hydraulic Oil Supply_002

1	Center cover
2	Tank cap

[3] Tighten the tank cap securely.

[4] Close the center cover and fasten with the catch clip.

2. Start the engine, raise and lower the mower units, and turn the steering wheel left and right. Move forward and reverse repeatedly several times.
3. Lower the mower units and maintain that position on a level surface, and then check to see if the oil level is at the middle of the oil gauge. If necessary, supply oil.
4. Check underneath the machine for oil leakage.

Handling Instructions

Hydraulic Hoses

Inspection of Hydraulic Hoses

Warning

When checking the hydraulic circuit for pinhole leaks or oil leakage from nozzles, do not use your hands. Use items such as paper or corrugated cardboard to find leakage points.

Be extremely careful with high-pressure oil as it may pierce your skin, resulting in personal accidents.

If fluid is injected into the skin it must be surgically removed within a few hours by a doctor familiar with this form of injury or gangrene may result.

Check the pipes and hoses to make sure that there is no oil leakage, circuit damage, looseness, wear, connector looseness, weather deterioration and chemical deterioration.

Make any necessary repairs before operating the machine.

Air Cleaner

Inspection of Air Cleaner

For details on handling the engine, please refer to the separate Engine Handling Manual. The air cleaner is a component that removes dirt from the intake air to prevent wear of the cylinder liners and piston rings so that the engine will always operate smoothly. A contaminated air cleaner element may cause malfunction of the engine.

1. Make sure that there is no damage to the air cleaner.
2. Make sure that the air cleaner element is not contaminated.

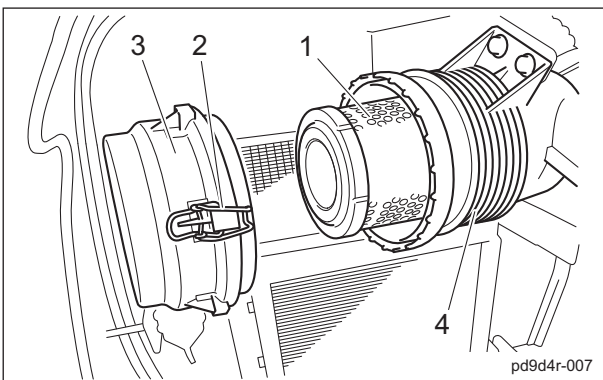

Inspection of Air Cleaner_001

1	Air cleaner element
2	Clip
3	Air cleaner cap
4	Air cleaner body

Cleaning of Air Cleaner

For details on handling the engine, please refer to the separate Engine Handling Manual. A contaminated air cleaner element may cause malfunction of the engine.

To maximize the life of the engine, clean the air cleaner properly.

1. Follow the steps below to clean the air cleaner.

[1] Remove the clips from the two locations, remove the air cleaner cap, and then remove the air cleaner element.

[2] While paying close attention not to damage the air cleaner element, tap a solid portion of the air cleaner element or blow compressed air from its inside to remove dust and dirt.

If the air cleaner element is extremely contaminated, replace it with a new one.

[3] Attach the air cleaner element to the air cleaner body.

[4] Replace the air cleaner cap, and then fix it securely with the clips.

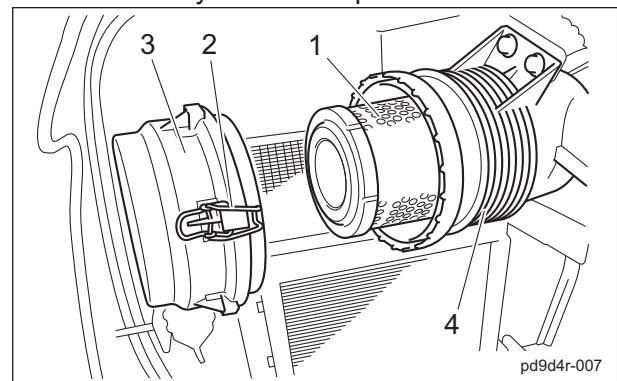

Cleaning of Air Cleaner_001

1	Air cleaner element
2	Clip
3	Air cleaner cap
4	Air cleaner body

Handling Instructions

Battery

Inspection of Battery

! Danger

Keep fire away while inspecting or charging the battery.
The battery may explode.

! Warning

Do not allow the battery fluid level to become lower than the LOWER LEVEL (minimum fluid level line).
The battery may explode if it is used or charged while the battery fluid level is at the LOWER LEVEL (minimum fluid level line).

! Caution

Implement after the engine and muffler etc. have well cooled down.
Otherwise you may get burned.

1. Clean the areas around the battery fluid level lines using a cloth dampened with water.
2. Make sure that the battery fluid level is between the UPPER LEVEL (maximum fluid level line) and the LOWER LEVEL (minimum fluid level line).

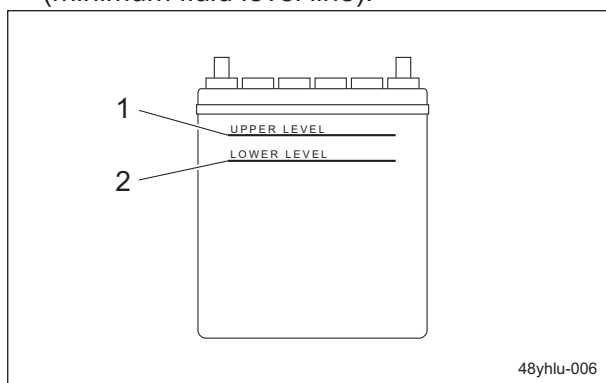

Inspection of Battery_001

1	UPPER LEVEL
2	LOWER LEVEL

Supply of Battery Fluid

! Danger

Be careful not to let your skin, eyes or clothes, etc., come into contact with the battery fluid or accidentally swallow the fluid.
Should your skin or clothes come into contact with the battery fluid, immediately wash them away with water.

! Danger

When you supply battery fluid, wear protective garments and safety glasses, etc.

! Caution

Implement after the engine and muffler etc. have well cooled down.
Otherwise you may get burned.

1. If the battery fluid level is lower than halfway between the UPPER LEVEL (maximum) line and LOWER LEVEL (minimum) line, add purified water up to the UPPER LEVEL (maximum) line.

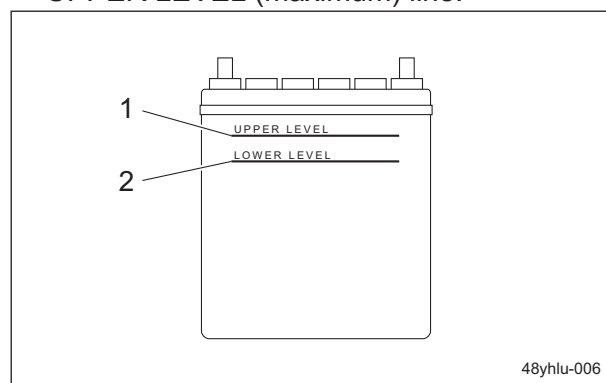

Supply of Battery Fluid_001

1	UPPER LEVEL
2	LOWER LEVEL

Handling Instructions

Electrical Wiring

Inspection of Electrical Wiring

Important

Electrical short circuit will cause fire, electrical leakage and malfunction of electrical equipments.

Inspect electrical wiring for poor terminal connections, damaged wiring or terminals, loose connections, weather-related deterioration and chemical-related deterioration.

If necessary, repair before operating the machine.

Tire

Inspection of Tires

1. Check the pneumatic pressure of the tires.
2. Make sure that there are no cracks, damage or abnormal wear.

	Tire size	Pneumatic pressure
Front wheel	(26.0 x 12.00 - 12)	140 kPa (1.4 kgf/cm ²)
Rear wheel	(20 x 10.00 - 10)	100 kPa (1.0 kgf/cm ²)

Brake

Inspection of Brake Pedal

1. When depressing the brake pedal fully, make sure that there is appropriate clearance between the floorboard and the pedal or pedal reserve distance.
2. When depressing the brake pedal fully, make sure that the pedal reaction is not spongy and that there is no noise.
3. When depressing the brake pedal during traveling, make sure that the machine stops smoothly and the braking is sufficiently effective.

Inspection of Parking Brake

1. Make sure that the parking brake is applied after depressing the brake pedal and moving the parking brake lock lever forward.

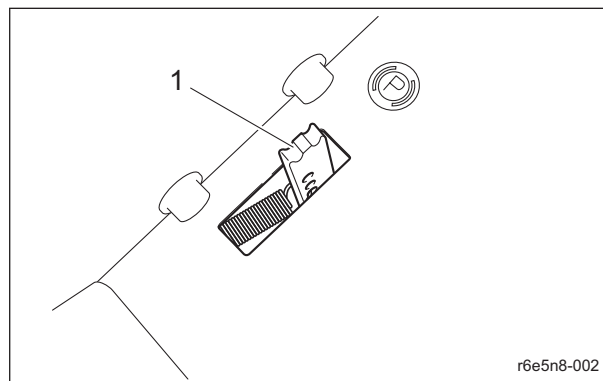

Inspection of Parking Brake 001

1 Parking brake lock lever

2. Make sure that the brake is not applied even slightly after you depress the brake pedal to release it.

Belt

Inspection of Belt

Warning

The engine must be stopped when the belt is inspected.

Important

A slacking or damaged belt or damaged fan may cause overheating or lack of a battery charge.

1. Press the middle of the belt with your finger to check the belt tension.
2. Make sure that there are no cracks, damage or abnormal wear.

Wire

Inspection of Wire

1. Make sure that the wire is not cracked or damaged.
2. If the wire is cracked or damaged, replace it with a new one immediately.

Safety Device

Inspection of Safety Device

Make sure that the safety device operates correctly.

"Safety Mechanisms" (Page 4-21)

Handling Instructions

Around The Engine

Inspection of Engine-Associated Parts

1. Check the fuel system parts for loosened or cracked joints and leakage. Replace the parts if necessary.
2. Blow compressed air to clean any grass or flammable materials that may be attached on or around the muffler.

Engine Oil

Inspection of Engine Oil

For details on handling the engine, please refer to the Owner's Manual for the engine.

Important

Securely tighten the oil level gauge and oil filler cap.

1. Stop the engine, wait for 10 to 20 minutes for the engine to cool down, then check the oil level.
2. Position the machine so that the engine will be level, then insert the oil gauge all the way to check the oil level.

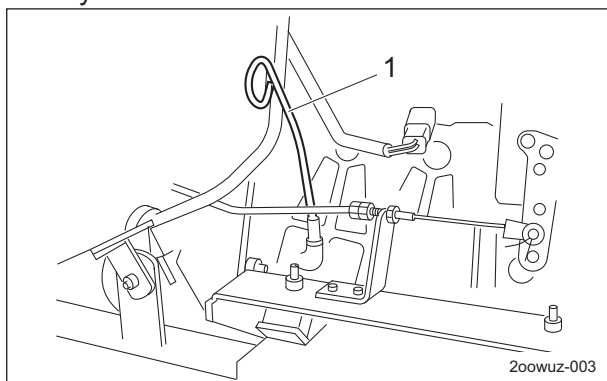

Inspection of Engine Oil_001

1	Oil gauge
---	-----------

3. The appropriate oil level should be between the upper and lower limit lines on the gauge.

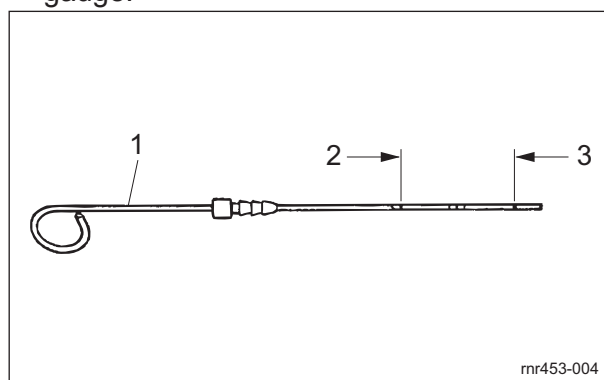

Inspection of Engine Oil_002

1	Oil gauge
2	Upper limit
3	Lower limit

Supply of Engine Oil

For details on handling the engine, please refer to the Owner's Manual for the engine.

Important

Do not supply too much engine oil. Otherwise, the engine may be damaged.

Important

Do not mix different types of engine oil.

Important

Be sure to use engine oil that is classified as API Service Grade CF or higher, with an SAE Viscosity that is appropriate for the operating environment (ambient temperature).

Important

Securely tighten the oil level gauge and oil filler cap.

1. Engine oil is supplied through the oil filling port.
Remove the oil filler cap, and then supply new engine oil until the oil reaches a level in between the upper and lower limit lines on the oil level gauge.

Handling Instructions

2. Securely install the oil filler cap.

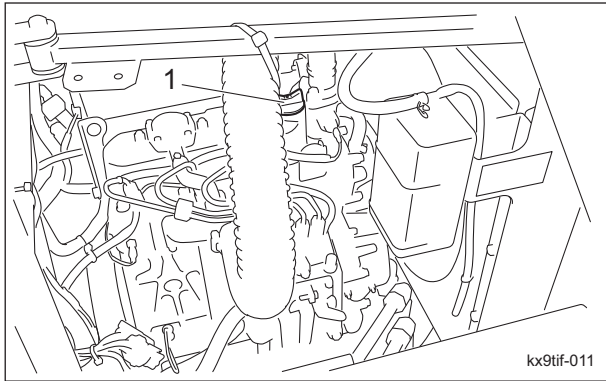

Supply of Engine Oil_001

1	Oil filler cap
---	----------------

3. It will take a while for the supplied engine oil to descend into the oil pan. Check the oil level again 10 to 20 minutes after supplying the oil.

Fuel

Inspection of Fuel Quantity

With the machine on a level surface, observe the fuel gauge in the operation panel to check the fuel level.

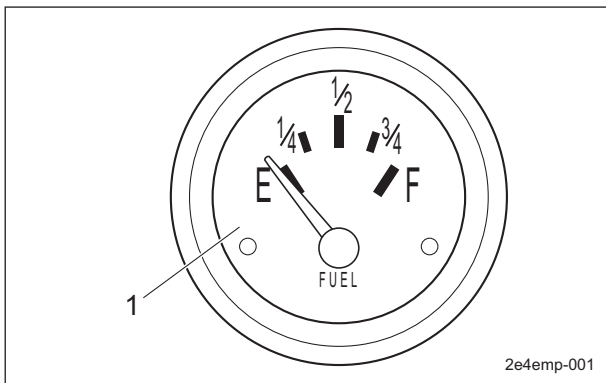

Inspection of Fuel Quantity_001

1	Fuel gauge
---	------------

Fuel Supply

Warning

Do not supply fuel above the middle (marked in red) of the fuel gauge. If you supply too much fuel, it might overflow from the fuel cap when you travel or work on a slope.

Warning

Keep fire away while refueling. Do not smoke while refueling.

If the fuel gauge located in the operation panel indicates a level close to E (EMPTY), supply fuel (diesel) at your earliest convenience.

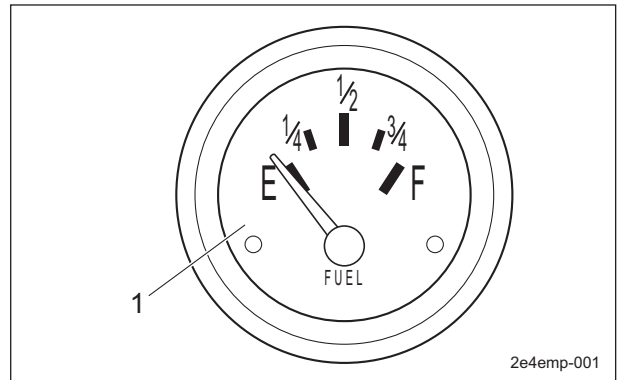

Fuel Supply_001

1	Fuel gauge
---	------------

Refuel up to the middle (marked in red) of the fuel gauge. The fuel tank capacity is approximately 38.0 dm³ (38.0 L).

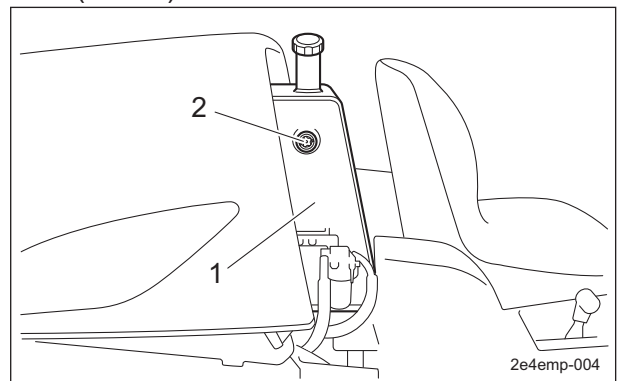

Fuel Supply_002

1	Fuel tank
2	Fuel gauge

Handling Instructions

Water Separator

Inspection of Water Separator

For details on handling the engine, please refer to the Engine's Owner's Manual.

Important

Water contamination in the fuel may decrease the engine starting performance and power output and may result in breakage of engine parts.

The water separator removes water from the fuel.

1. Make sure that debris and water have not accumulated in the cup.
With the float raised, water incorporation is confirmed.
When the float reaches the discharge level, discharge water.

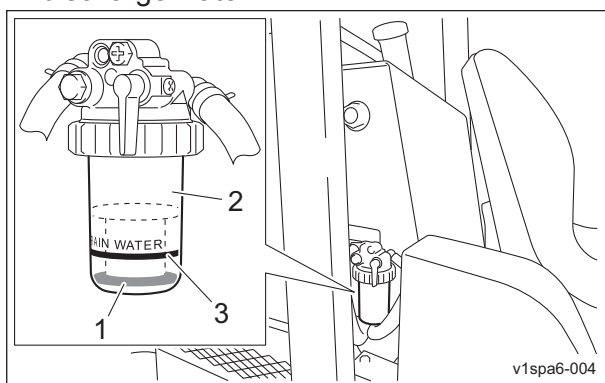

Inspection of Water Separator_001

1	Float
2	Cup
3	Discharge level

Draining of Water Separator

Important

Water contamination in the fuel may decrease the engine starting performance and power output and may result in breakage of engine parts.

Drain water from the water separator according to the maintenance schedule. And drain water whenever the float is raised by water.

1. Stop the engine, and then turn the key switch to the "OFF" position.
2. Place a container under the water separator.

3. Close the fuel filter cock.
4. Close the fuel cock of water separator.

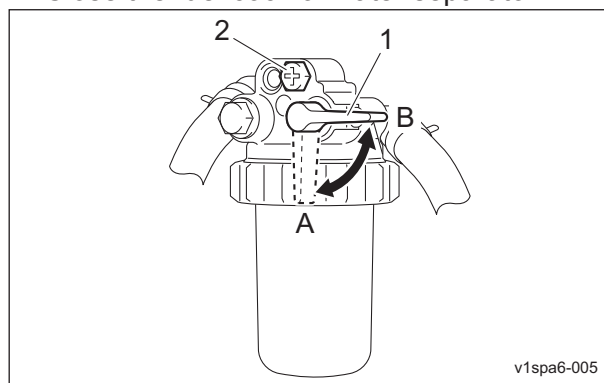

Draining of Water Separator_001

1	Fuel cock
2	Air-bleeding plug
A	ON (Open)
B	OFF (Close)

5. Remove the retaining ring and then remove the cup.

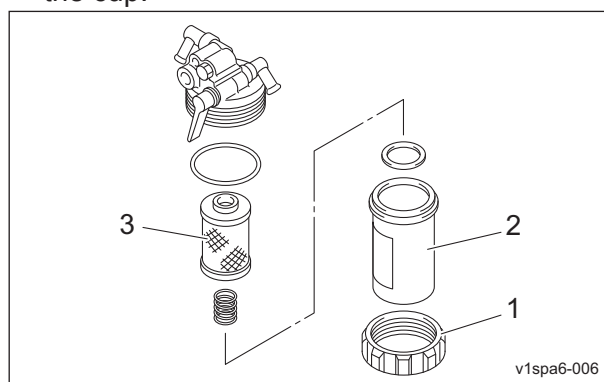

Draining of Water Separator_002

1	Retaining ring
2	Cup
3	Element

6. Discharge water from the cup.

Important

When installed, be careful that it is not contaminated with dirt or dust. If the fuel is contaminated with dirt or dust etc., the fuel injection pump and injection nozzle will become worn.

7. Put the parts back together.
8. Fill up the fuel tank with fuel and open the fuel cock.

Handling Instructions

9. Open the fuel cock of water separator.

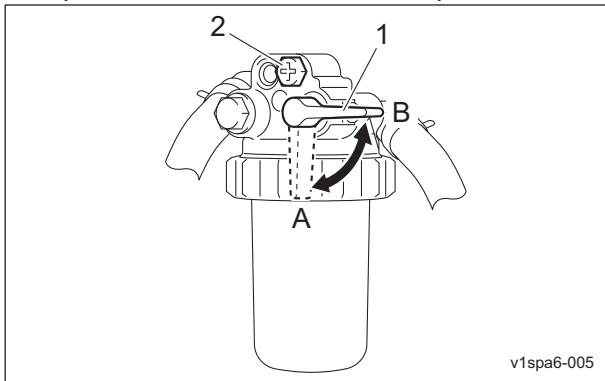

Draining of Water Separator_003

1	Fuel cock
2	Air-bleeding plug
A	ON (Open)
B	OFF (Close)

10. Loosen the air-bleeding plug by one turn.

11. Set the ignition key to the "ON" position.

After the fuel pump operated, the cup becomes filled with fuel and air bleeding occurs automatically.

12. Turn the key to the "START" position and remove air out of the fuel line.

13. In the case that there are still air bubbles in the fuel from air-bleeding plug even after 15 seconds or more pass after setting the ignition key to "START", pause for 30 seconds or more and then repeat the same steps.

14. Tighten the air-bleeding plug.

Cleaning of Water Separator

Important

Water contamination in the fuel may decrease the engine starting performance and power output and may result in breakage of engine parts.

Clean the water separator according to the maintenance schedule.

And clean it whenever debris has accumulated in the cup.

1. Stop the engine, and then turn the ignition key to the "OFF" position.
2. Place a container under the water separator.
3. Close the fuel filter cock.

4. Close the fuel cock of water separator.

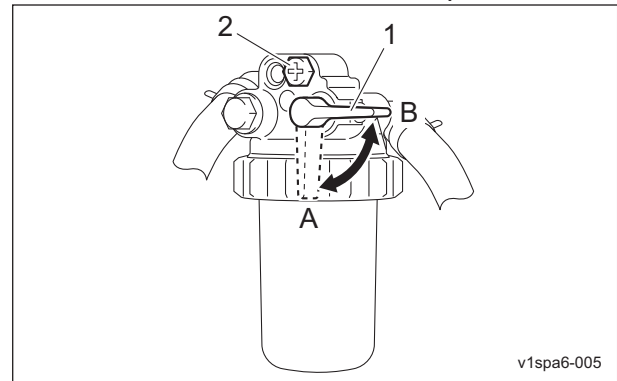

Cleaning of Water Separator_001

1	Fuel cock
2	Air-bleeding plug
A	ON (Open)
B	OFF (Close)

5. Remove the retaining ring and then remove the cup.

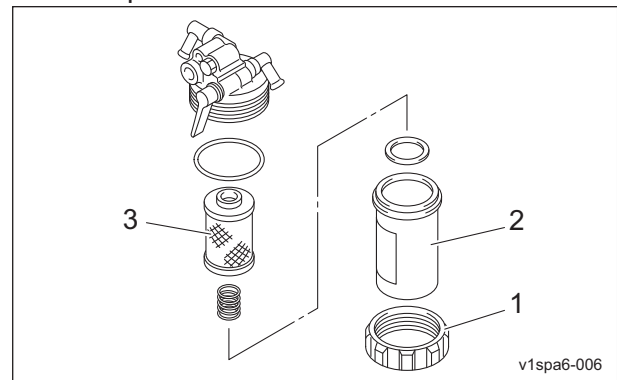

Cleaning of Water Separator_002

1	Retaining ring
2	Cup
3	Element

6. Discharge water from the cup.

7. Clean the cup and element with light oil.

Replace the element with new one as necessary.

Important

When installed, be careful that it is not contaminated with dirt or dust.

If the fuel is contaminated with dirt or dust etc., the fuel injection pump and injection nozzle will become worn.

8. Put the parts back together.

9. Fill up the fuel tank with fuel and open the fuel cock.

Handling Instructions

10. Open the fuel cock of water separator.

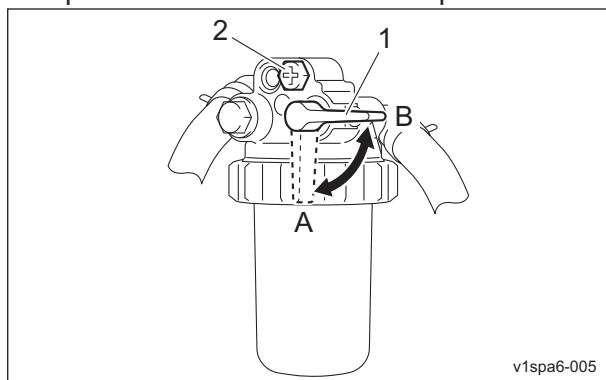

Cleaning of Water Separator_003

1	Fuel cock
2	Air-bleeding plug
A	ON (Open)
B	OFF (Close)

11. Loosen the air-bleeding plug by one turn.
12. Set the ignition key to the "ON" position.
After the fuel pump operated, the cup becomes filled with fuel and air bleeding occurs automatically.
13. Turn the key to the "START" position and remove air out of the fuel line.
14. In the case that there are still air bubbles in the fuel from air-bleeding plug even after 15 seconds or more pass after setting the ignition key to "START", pause for 30 seconds or more and then repeat the same steps.
15. Tighten the air-bleeding plug.

Fuel Filter

Inspection of Fuel Filter

The fuel filter works to remove foreign objects mixed into the fuel.

When the fuel flow becomes insufficient, replace the fuel filter if necessary.

1. Make sure that there is no fuel leakage.
2. Make sure that the fuel filter is not damaged or dirty.

Oil Leakage

Inspection of Oil Leakage

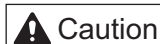

When performing maintenance on the hydraulic system, lower the mower units.

After approximately 50 hours of operation, some tightened portions may be loosened and oil and grease may leak.

Be sure to retighten the parts.

Check the bottom of the machine for oil and grease leakage.

Grass Catcher

Inspection of Grass Catcher

The grass catcher may no longer correctly collect grass clippings due to its wear, damage, deformation, etc., caused by frequent use.

1. Make sure that there is no wear or deterioration of the grass catcher.
2. Make sure that there is no damage to the grass catcher.
3. Make sure that there is no interference to moving parts due to deformation of the grass catcher.

Handling Instructions

Tightening Torques

Important

Refer to the Tightening Torque table.
Note that the Baroness product warranty may not apply to defects caused by incorrect or overtorque tightening, etc.

Standard Tightening Torques

Bolts and Nuts

Important

A number of bolts are used in each part of this machine.
Be sure to re-tighten the bolts and nuts, because they may be loosened at the earlier stage of the use.

As to the bolts and nuts without any special instruction, tighten them in appropriate tightening torque with proper tool.

Too much tightening may cause the looseness or damage of the screw.

The strength of tightening is determined by types of screws, strength, the friction of thread face or base face and others.

The table below is for the galvanized or parkerized bolts.

In case that the strength of internal thread is weak, it is not applied.

Do not use rusty or sand attached "screw."

Otherwise, it may cause insufficient tightening even if you apply the specified tightening torque.

The friction of the screw face becomes higher and the tightening torque is canceled out by the friction, therefore sufficient tightening cannot be applied.

If "screw" is wet by water or oil, do not tighten it with normal tightening torque.

If the screw is wet, the torque coefficient will get smaller and it may result in too much tightening.

Too much tightening may cause looseness by the screw stretched or result in damage.



Do not use a bolt experienced too much burden.

Using the impact wrench requires the skill.

Do exercise as much as possible for steady tightening.

Handling Instructions

Nominal diameter	General bolt		
	Strength classification 4.8		
	 tib3yb-001		
	N-m	kgf-cm	lb-in
M5	3 - 5	30.59 - 50.99	26.55 - 44.26
M6	7 - 9	71.38 - 91.77	61.96 - 79.66
M8	14 - 19	142.76 - 193.74	123.91 - 168.17
M10	29 - 38	295.71 - 387.49	256.68 - 336.34
M12	52 - 67	530.24 - 683.20	460.25 - 593.02
M14	70 - 94	713.79 - 958.52	619.57 - 831.99
M16	88 - 112	897.34 - 1142.06	778.89 - 991.31
M18	116 - 144	1,182.85 - 1,468.37	1,026.72 - 1,274.54
M20	147 - 183	1,498.96 - 1,866.05	1,301.10 - 1,619.73
M22	295	3,008.12	2,611.05
M24	370	3,772.89	3,274.87
M27	550	5,608.35	4,868.05
M30	740	7,545.78	6,549.74

Nominal diameter	Heat-treated bolt					
	Strength classification 8.8			Strength classification 10.9		
	 tib3yb-002			 tib3yb-003		
	N-m	kgf-cm	lb-in	N-m	kgf-cm	lb-in
M5	5 - 7	50.99 - 71.38	44.26 - 61.96	7 - 10	71.38 - 101.97	61.96 - 88.51
M6	8 - 11	81.58 - 112.17	70.81 - 97.36	14 - 18	142.76 - 183.55	123.91 - 159.32
M8	23 - 29	234.53 - 295.71	203.57 - 256.68	28 - 38	285.52 - 387.49	247.83 - 336.34
M10	45 - 57	458.87 - 581.23	398.30 - 504.51	58 - 76	591.43 - 774.97	513.36 - 672.68
M12	67 - 85	683.20 - 866.75	593.02 - 752.34	104 - 134	1,060.49 - 1,366.40	920.50 - 1186.03
M14	106 - 134	1,080.88 - 1,366.40	938.21 - 1,186.03	140 - 188	1,427.58 - 1,917.04	1,239.14 - 1,663.99
M16	152 - 188	1,549.94 - 1,917.04	1,345.35 - 1,663.99	210 - 260	2,141.37 - 2,651.22	1,858.71 - 2,301.26
M18	200 - 240	2,039.40 - 2,447.28	1,770.20 - 2,124.24	280 - 340	2,855.16 - 3,466.98	2,478.28 - 3,009.34
M20	245 - 295	2,498.27 - 3,008.12	2,168.50 - 2,611.05	370 - 450	3,772.89 - 4,588.65	3,274.87 - 3,982.95
M22	-	-	-	530	5,404.41	4,691.03
M24	-	-	-	670	6,831.99	5,930.17
M27	-	-	-	1,000	10,197.00	8,851.00
M30	-	-	-	1,340	14,628.78	11,860.34

Note:

The same values are applied to "fine screw thread."

Handling Instructions

Hydraulic Hose

The tightening torques for union joints and union adaptors with parallel pipe threads (G, PF) are shown in the table below.

A union joint or adaptor will not become loose or leak as long as it is tightened by the specified torque.

If fluid leaks from the sealed portion, do not attempt to tighten the union joint or adaptor forcibly.

Examine whether any foreign matter or scratches are present on the seat surface.

Tightening a union joint or adaptor forcibly could damage the connection of the joints.

When tightening a union joint or adaptor, use a torque wrench where possible and firmly tighten it by an appropriate torque.

Nominal diameter of the hose size	Nominal diameter of the parallel pipe threads (PF)	Tightening torque		
		N-m	kgf-cm	lb-in
6	1/4	24.50	250	221.28
9	3/8	49.03	500	564.91
12	1/2	58.84	600	677.89
15	3/4	117.68	1200	1,355.78
19	3/4	117.68	1200	1,355.78
25	1	137.30	1400	1,581.74
32	1-1/4	166.72	1700	1,920.69
38	1-1/2	205.94	2100	2,372.61
50	2	245.17	2500	2,824.54

Fittings with Parallel Threads (O-Ring Seal Type)

The tightening torques for fittings with parallel threads (O-ring seal method) are shown in the table below.

Tightening the fitting forcibly with a spanner or other such tool to secure it to a set position could damage the fitting, its washers, and other parts. Be sure to tighten the fitting to the torque appropriate to its size.

Nominal diameter of thread	Tightening torque		
	N-m	kgf-cm	lb-in.
1/4	34.32 - 49.03	350 - 500	309.79 - 442.55
3/8	68.65 - 78.45	700 - 800	619.57 - 708.08
1/2	98.07 - 117.68	1000 - 1200	885.10 - 1,062.12
3/4	147.10 - 176.52	1500 - 1800	1,327.65 - 1,593.18
1	245.17 - 274.59	2500 - 2800	2,212.75 - 2,478.28
1-1/4	294.20	3000	2,655.30
1-1/2	294.20	3000	2,655.30
2	392.27	4000	3,540.40

Handling Instructions

Principal Tightening Torques

Tightening Torque by Model

LM531

Tighten the following bolts and nuts to the torque specified in the table.

For thread locking adhesive, apply a medium strength thread locker (ThreeBond 1322 anaerobic adhesive or equivalent).

Location	Code	Part name	Tightening torque			Thread locking adhesive	
			N-m	kgf-cm	lb-in		
Front wheel	Motor	K0010120902	Bolt, heat-treated M12-90	104 - 134	1,060.49 - 1,366.40	920.50 - 1,186.03	—
	Wheel mounting base	-	Slotted nut attached to hydraulic motor 1-20UNEF	280 - 300	2,855.16 - 3,059.10	2,478.28 - 2,655.30	—
	Wheel	K0011120352	Bolt, heat-treated M12-35P1.5	110	1121.69	973.61	—
Rear wheel	Motor	K0013120702	Bolt, heat-treated M12-70	104 - 134	1,060.49 - 1,366.40	920.50 - 1,186.03	—
	Wheel mounting base	-	Slotted nut attached to hydraulic motor 1-20UNEF	280 - 300	2,855.16 - 3,059.10	2,478.28 - 2,655.30	—
	Wheel	K0011120352	Bolt, heat-treated M12-35P1.5	110	1121.69	973.61	—
Engine	K0017100252	Bolt, small, heat-treated M10-25P1.25	45 - 57	458.87 - 581.23	398.30 - 504.51	—	
		Bolt, small, heat-treated M10-25P1.25 (Top left front of engine)	29 - 38	295.71 - 387.49	256.68 - 336.34	—	
	K3680000030	M3.5 screw (accessories)	0.78 - 1.18	7.95 - 12.03	6.90 - 10.44	—	
Tie rod	(K1610000020)	Slotted nut (Tie rod end right Assy)	45	158.87	98.3	—	
	(K1611000020)	Slotted nut (Tie rod end left Assy)	45	158.87	98.3	—	
Kingpin stopper	K0000100252	Bolt, M10-25	29 - 38	295.71 - 387.49	256.68 - 336.34	—	
Cross-valve	K0013101252	Bolt, heat-treated M10-125	29 - 38	295.71 - 387.49	256.68 - 336.34	—	
Universal joint	K001A100401	Bolt, w/hexagon hole, M10-40	62 - 72	632.21 - 734.18	548.76 - 637.27	○	
	K0011100252	Bolt, heat-treated M10-25P1.25	58 - 76	591.43 - 774.97	513.36 - 672.68	—	
ROPS	K0010120402	Bolt, heat-treated M12-40	104 - 134	1,060.49 - 1,366.40	920.50 - 1,186.03	—	
Mower stopper	K0041060122	Screw, + flat head M6-12	—	—	—	○	

Handling Instructions

Adjustment before Work

Adjustment of Steering Wheel

Warning

Since it is dangerous, do not adjust the steering wheel while traveling.

Caution

Be sure the steering wheel position is securely locked. It may result in an unexpected accident if it becomes loose while traveling.

The steering wheel can be adjusted up or down. Adjust the position according to the operator's body size. Shift the tilt lever to the "FREE" position, move the steering wheel to the position that suits your work requirements, and then shift the tilt lever to the "LOCK" position to secure the steering wheel in place. The tilt lever is located at the left in front of the driver's seat.

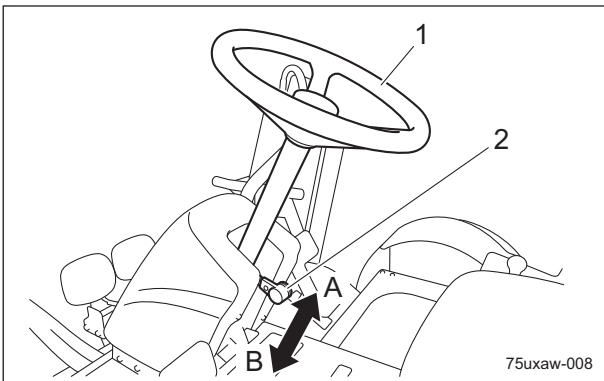

Adjustment of Steering Wheel_001

1	Steering wheel
2	Tilt lever
A	FREE (released)
B	LOCK (locked)

Adjustment of Seat

Use the seat adjustment levers to adjust the seat.

Adjust the position to fit the operator.

1. Use the forward/backward adjustment lever to adjust the seat back and forth.
2. Use the backrest tilt adjustment lever to adjust the angle of the backrest.
3. Pull out the suspension adjustment handle and move it up or down to adjust the firmness of the seat suspension. Observe the suspension adjustment scale while making adjustments. [50 - 160 kg (110.2 - 352.7 lb)]

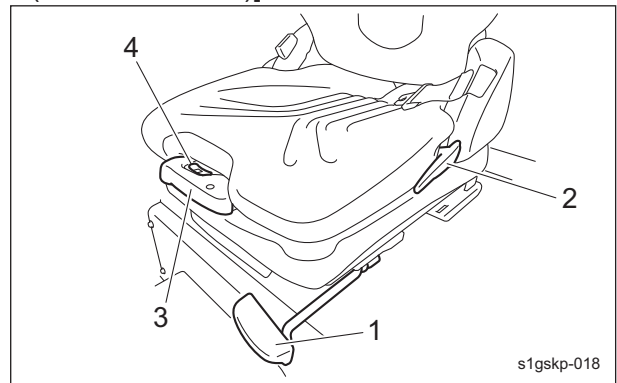

Adjustment of Seat_001

1	Forward/backward adjustment lever
2	Angle adjustment lever
3	Suspension adjustment handle
4	Suspension adjustment scale

Handling Instructions

Adjustment of Mower Stopper Pin

Note:

Depending on the specifications, this function may not be available.

The mower stopper pin can prevent or allow tilting of the mower units.

Adjust according to the operating conditions.

Fixed:

- The mowing line while traveling straight ahead is a straight line. (The mowing line is easy to see.)
- The mower units do not tilt while operating on slopes, and incomplete mowing can be reduced.

Released:

- It is appropriate when turning while mowing or it is easy to follow undulations.
1. With the machine on a level surface, lower all mower units.
 2. Apply the parking brake, and then stop the engine.
 3. Adjust the position of the mower stopper pin, and then insert the cotter pin.

To fix:

Insert the cotter pin into the upper hole in the mower stopper pin.

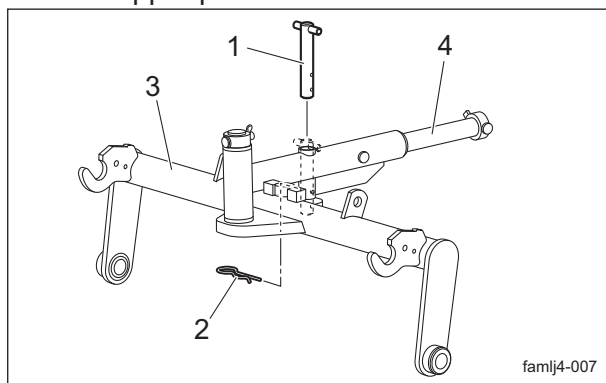

Adjustment of Mower Stopper Pin_001

1	Mower stopper pin
2	Cotter pin
3	Mower arm
4	Mower coupling

To release:

Insert the cotter pin into the lower hole in the mower stopper pin.

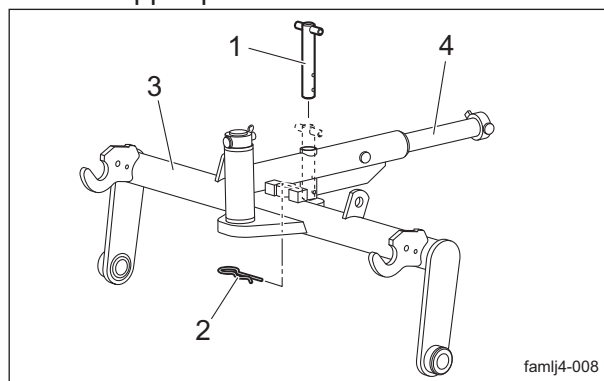

Adjustment of Mower Stopper Pin_002

1	Mower stopper pin
2	Cotter pin
3	Mower arm
4	Mower coupling

Handling Instructions

Procedure to Start/Stop Engine

Start/Stop of Engine

Procedure to Start Engine

1	Fuel cock
A	ON (Open)
B	OFF (Close)

Caution

Before starting the engine, make sure that there are no other people or obstacles around the machine.

Important

Starter operation must take 15 seconds or less.
If the engine still does not start, stop using the battery for 30 to 60 seconds to avoid exhausting the battery.

1. Open the fuel cock of the water separator.
The water separator is located on the right side of the fuel tank.

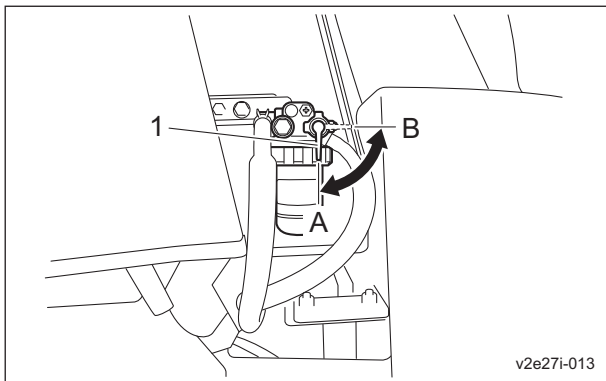

Procedure to Start Engine_001

1	Fuel cock
A	ON (Open)
B	OFF (Close)

2. Open the fuel cock of the fuel filter.
The fuel filter is located on the left under the hood.

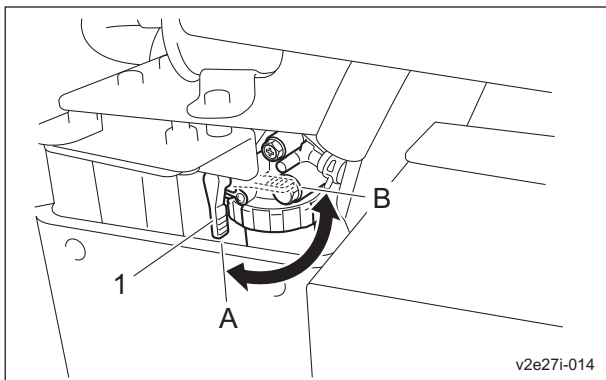

Procedure to Start Engine_002

3. Sit on the seat.
4. Depress the brake pedal and make sure that the parking brake is applied.
5. Make sure that the reel rotation switch is set to the "Stop" position.
6. Make sure that the mower unit up/down lever is set to the "Neutral" position.
7. Make sure that the traveling pedal is in the neutral position.
8. Move the throttle lever halfway from the "Low speed" position toward the "High speed" position.

Important

The thermo-start lamp turns off at the specified time. However, the lamp turning off is not related to the glow plug generating heat. If the ignition key is left in the "GLOW" position after the lamp is turned off, the plug will still generate heat. The thermo-start lamp will stay illuminated for five seconds.

9. Switch the ignition key to the "GLOW" position.
10. Make sure that the glow plug is generating heat and the thermo-start lamp is turned on.
11. After the thermo-start lamp turns off, immediately set the ignition key to the "START" position.

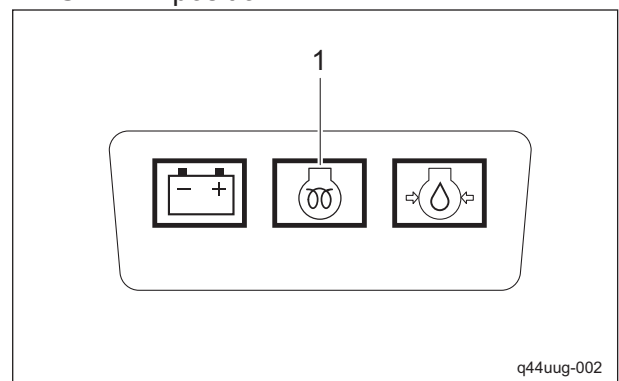

Procedure to Start Engine_003

1	Thermo-start lamp
---	-------------------

Handling Instructions

Important

Quickly returning the ignition key from the "START" position to the "ON" position may result in damage to the machine.

12. When the starter starts rotating and the engine starts, return the ignition key to the "ON" position slowly.
13. Make sure that the charge lamp and oil pressure lamp turn off. If they do not turn off, stop the engine and inspect the machine.

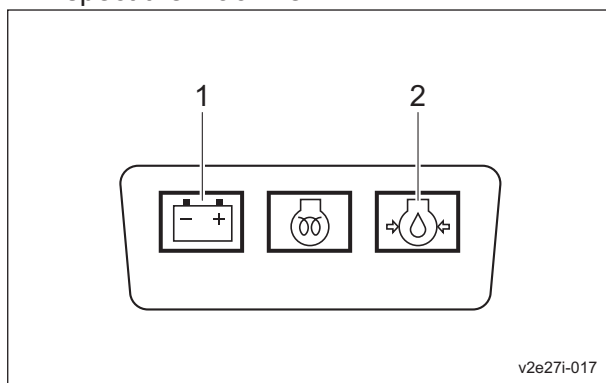

Procedure to Start Engine_004

1	Charge lamp
2	Oil pressure lamp

14. Shift the throttle lever to the "Low speed" position, and then warm up the engine for 1-2 minutes.
15. Gradually move the throttle lever toward the "High speed" position.

Procedure to Stop Engine

1. Set the traveling pedal to the neutral position.
2. Depress the brake pedal and move the parking brake lock lever forward to lock the brake.
3. Set the reel rotation switch to the "Stop" position.
4. Raise all the mower units.
5. Shift the throttle lever to the "Low speed" position, and then idle the machine for 1-2 minutes.
6. Switch the ignition key to the "OFF" position.
7. Make sure that the engine has stopped.
8. Set the anti-falling stop valve to the "Stop" position.

9. Hook the mower lock levers (latches) for the mower units #4 and #5.
10. Remove the ignition key.
11. Leave the driver's seat.
12. Close the fuel cock of the fuel filter.
13. Close the fuel cock of the water separator.

Safety Mechanisms

This machine features a safety device for starting/stopping the engine.

1. As for starting the engine, the safety device prevents the engine from starting unless it meets each of the following four conditions.
 - An operator is sitting on the seat.
 - The parking brake is applied.
 - The reel rotation switch is set to the "OFF" position.
 - The traveling pedal is set to the neutral position.
2. In the event the operator leaves the seat with the parking brake applied and the engine running, the safety device will be activated and will stop the engine under any of the following conditions:
 - The traveling pedal is not set to the neutral position. (The operator has depressed the traveling pedal.)
 - The reel rotation switch is set to the "Rotate" position. However, when the reel reverse switch is set to the "ON" position (reverse rotation), the engine does not stop.

Handling Instructions

Warning Mechanisms

⚠ Caution

When the buzzer (intermittent tone) sounds, be sure to stop operation since the engine is overheated.

Do not stop the engine without idling. Allow the engine to cool down, first. Keep the engine idling for about 5 minutes before stopping. Remove dust that is jamming in the radiator, air cleaner, and etc.

This machine features warning mechanisms for overheating and for the hydraulic oil level.

1. If water temperature inside the engine exceeds 105 °C (221 °F), a buzzer will sound. (intermittent tone)
2. If the oil level in the hydraulic tank declines from the specified level by approximately 4.2 dm³ (4.2 L), a buzzer will sound. (intermittent tone)

Operation Method

Cautions for when You Leave The Machine

⚠ Caution

If the brakes are not sufficiently effective, use the wheel stoppers to secure the machine.

⚠ Caution

Never park the machine on a slope.

1. Park the machine on level ground.
2. Apply the parking brake.
3. Stop the engine.
4. Remove the ignition key.
5. Leave the machine.

Positions of Operation Decals

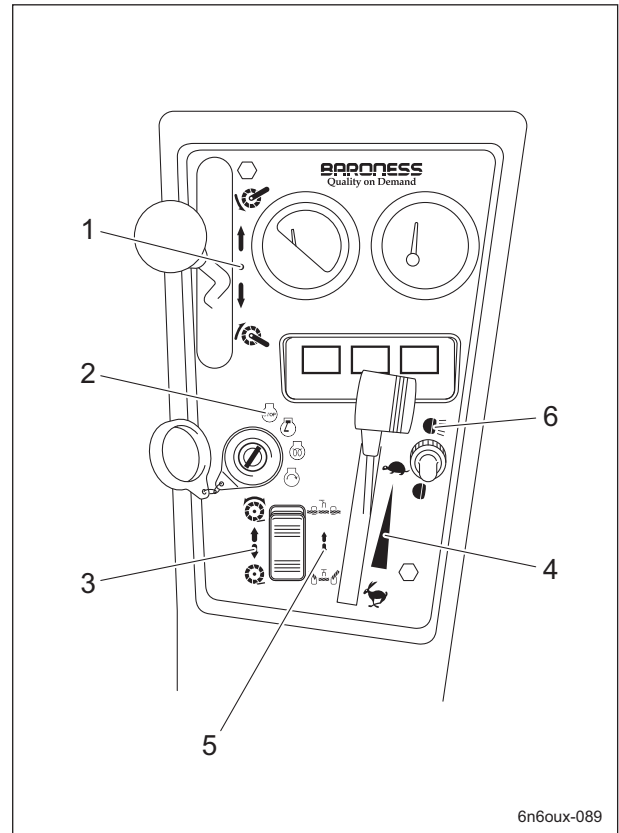

6n6oux-089

Positions of Operation Decals_001

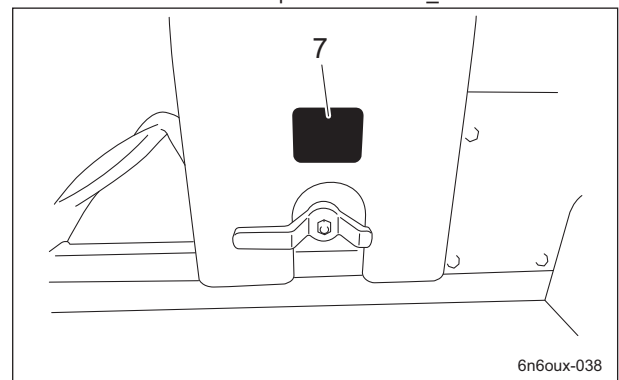

6n6oux-038

Positions of Operation Decals_002

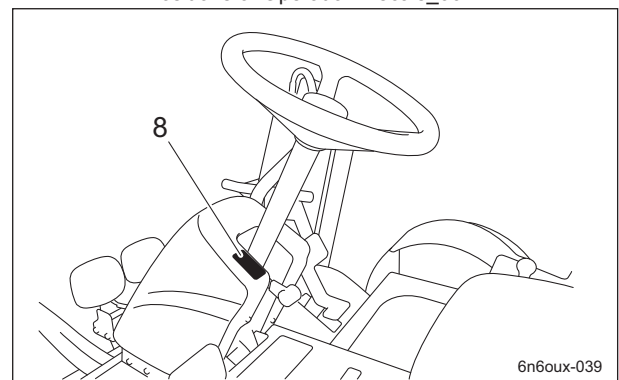

6n6oux-039

Positions of Operation Decals_003

Handling Instructions

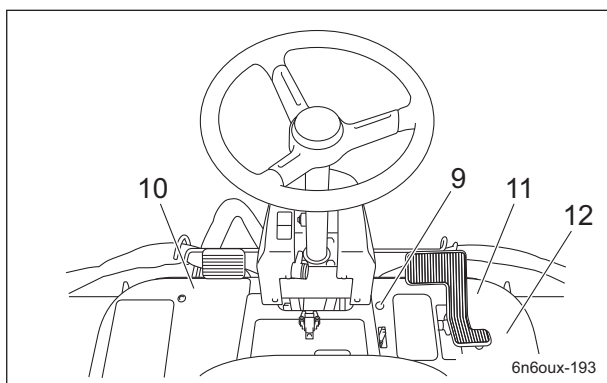

Positions of Operation Decals_004

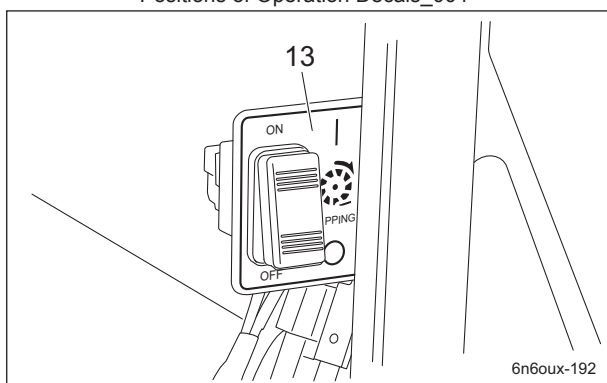

Positions of Operation Decals_005

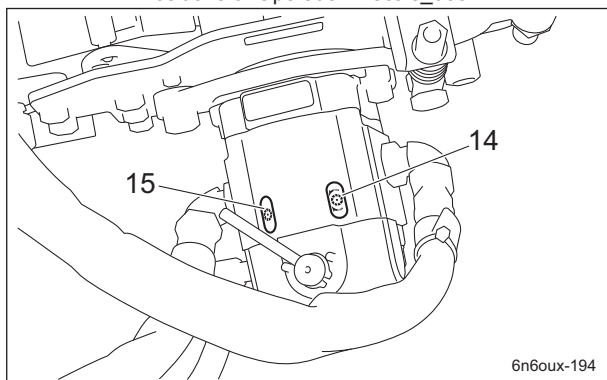

Positions of Operation Decals_006

1	Mower unit up/down decal
2	Key switch decal
3	Reel rotation mark
4	Engine rotation mark
5	Traveling/working selector mark
6	Light switch mark
7	Stop valve operation decal
8	Tilt steering decal
9	Brake mark
10	BRAKE decal
11	FORWARD decal
12	BACKWARD decal
13	Lapping switch decal
14	Reel rotation decal
15	Reel stop decal

Description of Operation Decals

Mower Unit Up/Down Decal

Decal, mower unit up/down
This indicates the Up/Down positions of the mower unit.

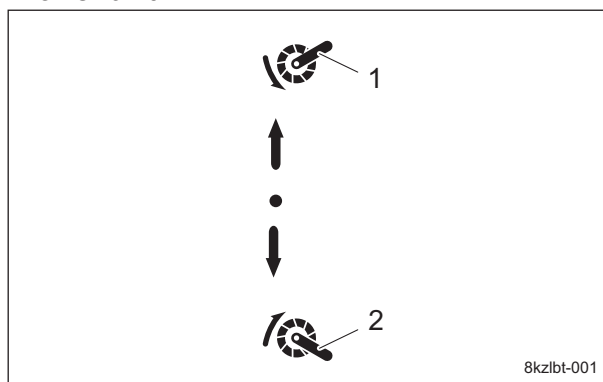

Mower Unit Up/Down Decal_001

1	Down
2	Up

Key Switch Mark

Key switch mark
This indicates the key switch positions.

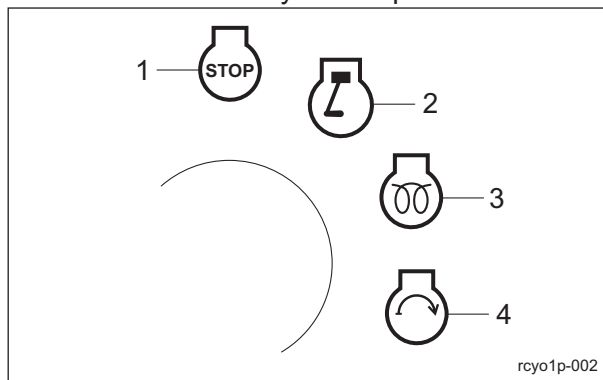

Key Switch Mark_001

1	OFF
2	ON
3	GLOW
4	START

Handling Instructions

Reel Rotation Mark

Reel rotation mark
It illustrates Rotation/Stop of the reel cutter (cutting cylinder).

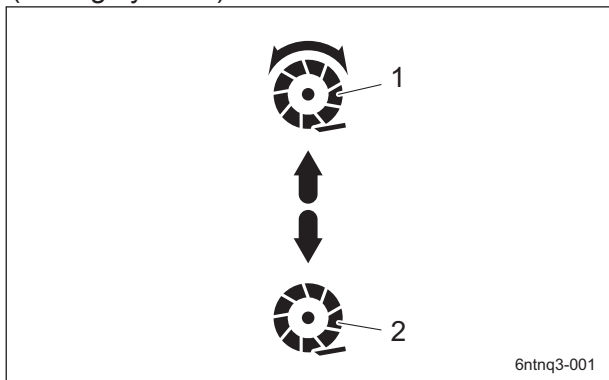

Reel Rotation Mark_001

1	Rotation
2	Stop

Traveling/Working Selector Mark

Traveling/working selector mark
It illustrates the positions where mower units #4 and #5 stop when they are raised. (ON/OFF of slight lift function)

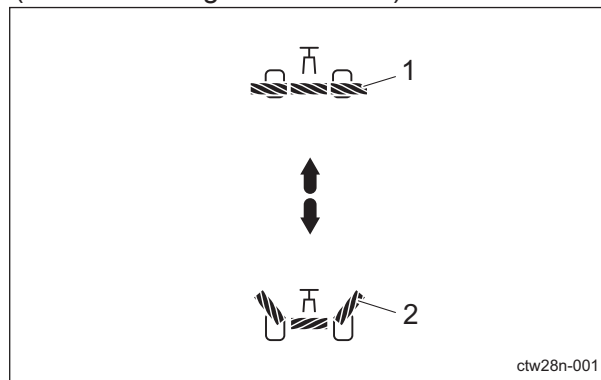

Traveling/Working Selector Mark_001

1	Working
2	Traveling

Engine Rotation Mark

Engine rotation mark
This indicates high/low speed of the engine rotation.

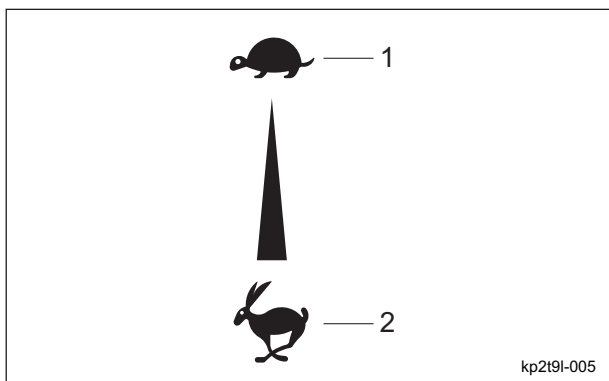

Engine Rotation Mark_001

1	Low speed
2	High speed

Light Switch Mark

Note:
Depending on the specifications, this function may not be available.
Light switch mark
It illustrates ON/OFF of the light.

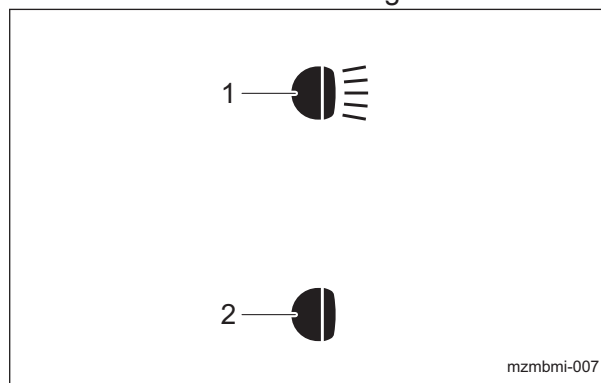

Light Switch Mark_001

1	ON
2	OFF

Handling Instructions

Stop Valve Operation Decal

K4203001290
 Stop valve operation decal
 It illustrates Stop/Open of the stop valve.

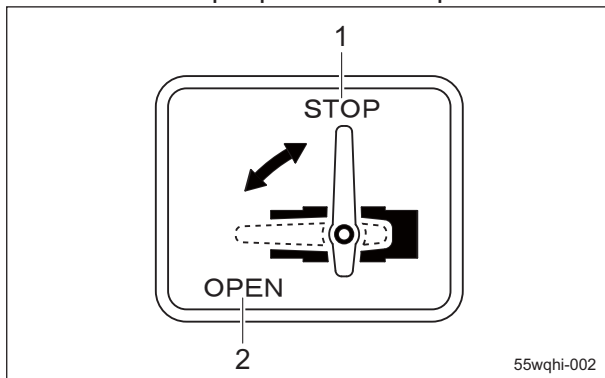

Stop Valve Operation Decal_001

1	Stop
2	Open

Brake Mark

K4209001200
 DECAL, BRAKE
 It illustrates the locking position for the parking brake.

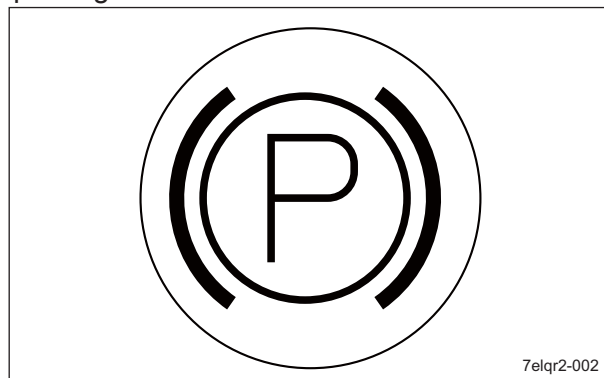

Brake Mark_001

Tilt Steering Decal

K4203001560
 Decal, tilt steering
 This illustrates the tilt directions of the steering wheel and the locked/free positions.

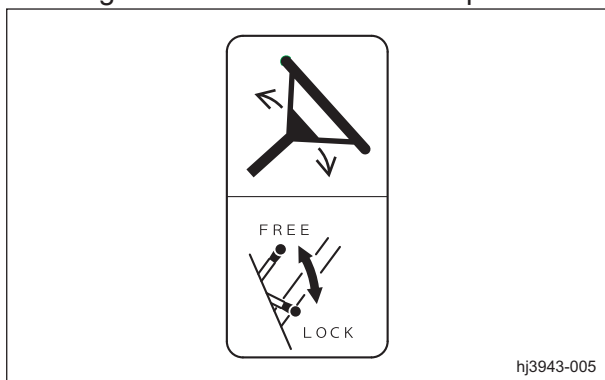

Tilt Steering Decal_001

BRAKE Decal

K4203001450
 Decal, BRAKE
 This indicates brake.

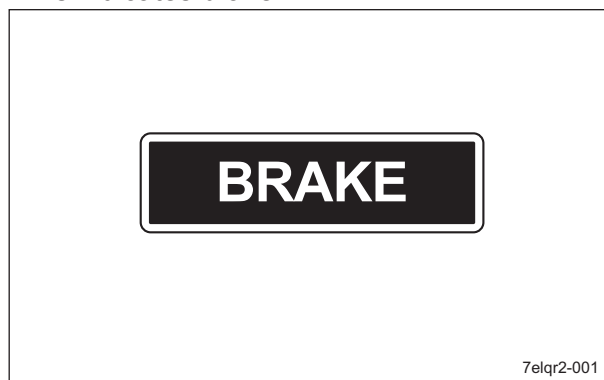

BRAKE Decal_001

FORWARD Decal

K4203001430
 Decal, FORWARD
 This indicates forward travel.

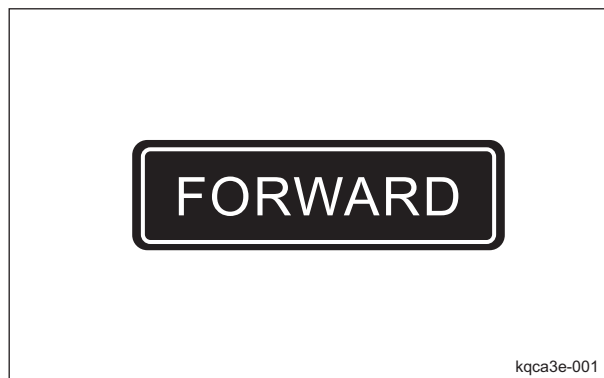

FORWARD Decal_001

Handling Instructions

BACKWARD Decal

K4203001440
Decal, BACKWARD
This indicates backward travel.



BACKWARD Decal_001

Reel Rotation Decal

K4203001300
Decal, reel rotation
This indicates rotation of the reel cutter (cutting cylinder).

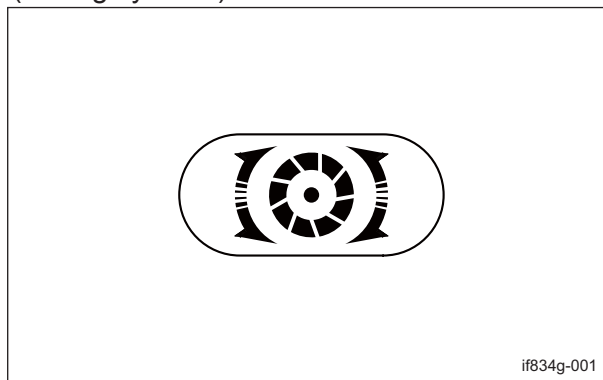

Reel Rotation Decal_001

Lapping Switch Decal

K4203001580
Decal, lapping switch
This indicates ON/OFF switching of back lapping operation.

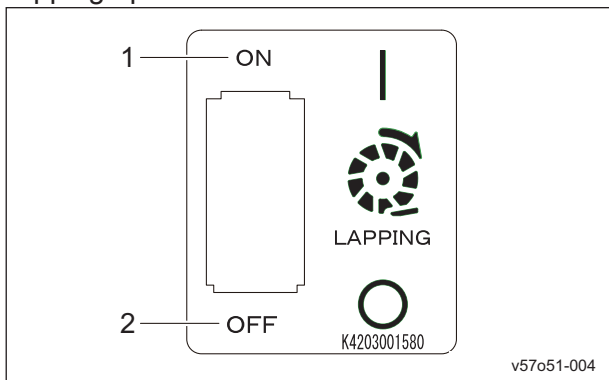

Lapping Switch Decal_001

1	Reverse rotation (back lapping rotation)
2	Normal rotation (cutting rotation)

Reel Stop Decal

K4203001310
Decal, reel stop
This indicates stop of the reel cutter (cutting cylinder).

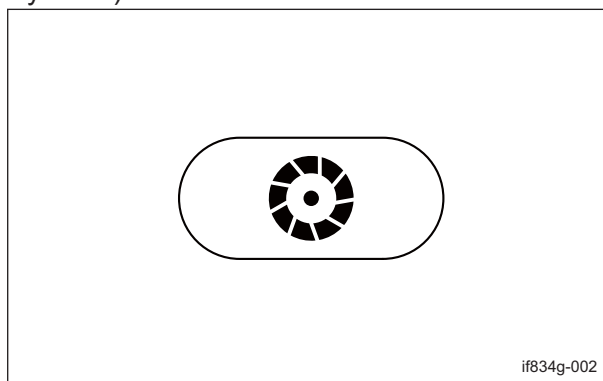

Reel Stop Decal_001

Handling Instructions

Light Switch

⚠ Caution

The lights provide auxiliary lighting.
Do not travel or operate the machine at night or under poor visibility.

Note:

Depending on the specifications, this function may not be available.

The light switch is located in the operation panel.

When the switch is set to the "ON" position, the lights turn on. When it is set to the "OFF" position, the lights turn off.

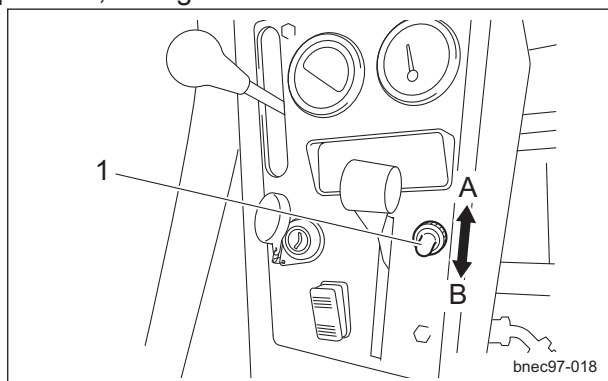

Light Switch_001

1	Light switch
A	ON
B	OFF

Note:

The lights will not turn on when the ignition key is switched to the "OFF" position.

Throttle Lever

The throttle lever is located in the operation panel and enables you to adjust the engine rpm.

Move the throttle lever toward the "High speed" position to increase the engine rpm, and toward the "Low speed" position to reduce the rpm.

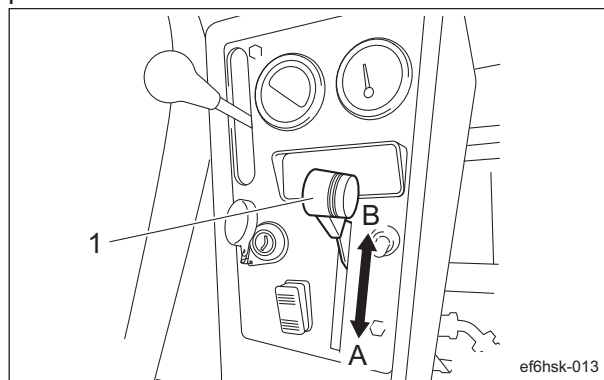

Throttle Lever_001

1	Throttle lever
A	High speed
B	Low speed

Handling Instructions

Mower Unit Up/Down Lever

Caution

Before raising or lowering the mower units, make sure that there are no people around the machine.

Caution

Be careful since shifting the mower unit up/down lever to the "DOWN" position lowers the mowers, even while the engine is stopped.

Important

Before operating the mower unit up/down lever, be sure to set the stop valve to the "Open" position.

Important

When the mower lock levers (latches) are engaged, do not operate the mower unit up/down lever.

The mower unit up/down lever is located in the operation panel and raises or lowers the mower units.

Shift the lever to the "DOWN" position to lower all the mower units, and shift it to the "UP" position to raise all the mower units.

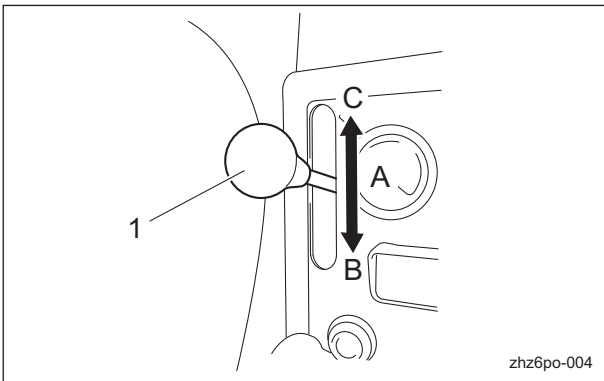

Mower Unit Up/Down Lever_001

1	Mower unit up/down lever
A	Neutral
B	Up
C	Down

Note:

Even if the reel rotation switch is set to the "Rotate" position, the reel cutter (cutting cylinder) stops rotating when the mower unit up/down lever is moved to the neutral position or the mower units are raised.

Stop Valve

Caution

When you move the machine, or if you stop the engine with the mower units raised, be sure to set the stop valve to the "Stop" position.

The stop valve is located underneath the right side of the driver's seat. This valve prevents all raised mower units from falling.

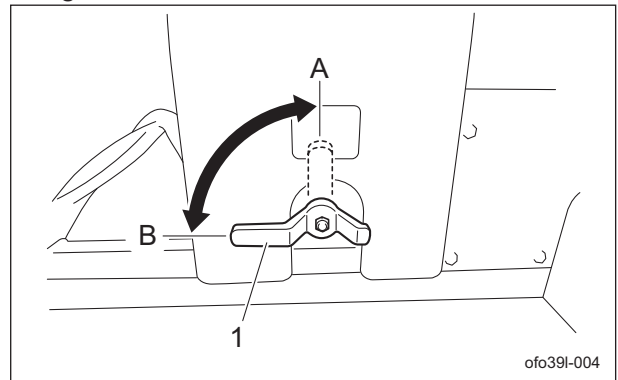

Stop Valve_001

1	Stop valve
A	Stop
B	Open

Handling Instructions

Mower Lock Lever (Latch)

The mower lock levers (latches) are located in the foot area on the left and right sides and are used when traveling or storing the machine with mower units #4 and #5 raised.

When storing the machine, secure the mower lock levers (latches).

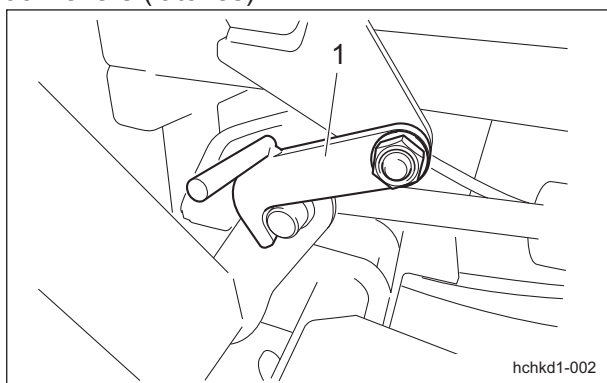

Mower Lock Lever (Latch)_001

1	Mower lock lever (latch)
---	--------------------------

Reel Rotation Switch

⚠ Caution

The reel rotation switch must be set just before you start cutting work. In cases other than those cases, it must be returned to the "Stop" position.

The reel rotation switch is located in the operation panel and operates rotation of the reel cutters (cutting cylinders) of the mower units.

If you set the reel rotation switch to the "Rotate" position, the reel cutters (cutting cylinders) of all mower units will rotate for cutting work. If you set the reel rotation switch to the "Stop" position, the reel cutters (cutting cylinders) will stop.

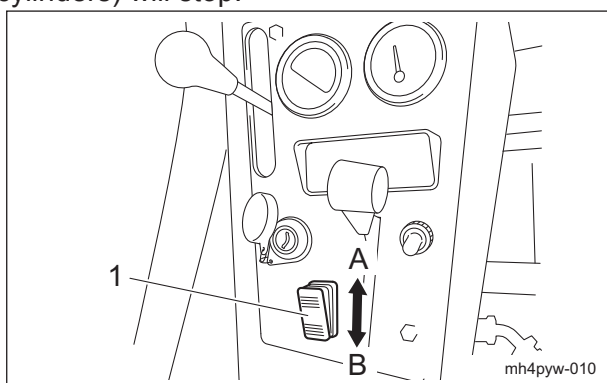

Reel Rotation Switch_001

1	Reel rotation switch
A	Rotate
B	Stop

Slight Lift Function

When the reel rotation switch is shifted to the "Rotate" side, the slight lift becomes functional and the mower units are raised only to a fixed height when the mower units are raised with the mower unit up/down lever.

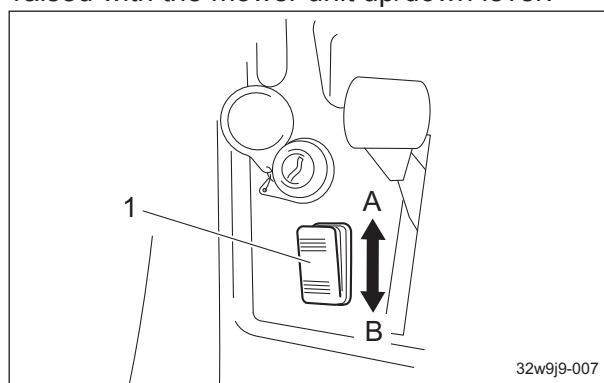

Slight Lift Function_001

1	Reel rotation switch
A	Rotate (Slight lift function "ON")
B	Stop (Slight lift function "OFF")

Handling Instructions

Reel Reverse Switch

Important

Do not switch the reel reverse switch to the "ON" or "OFF" position while the reel cutter (cutting cylinder) is rotating. Otherwise, a hydraulic system will malfunction.

Important

If the reel rotation switch is not set to the "Rotate" position, the reel cutter (cutting cylinder) will not rotate.

The reel reverse switch is located under the hood. This switches the rotation direction of the reel cutter (cutting cylinder). When the reel reverse switch is set to the "Reverse rotation" position, the reel cutters (cutting cylinders) of all mower units rotate in reverse (back lapping rotation). When the reel reverse switch is set to the "Normal rotation" position, the reel cutters (cutting cylinders) rotate for mowing.

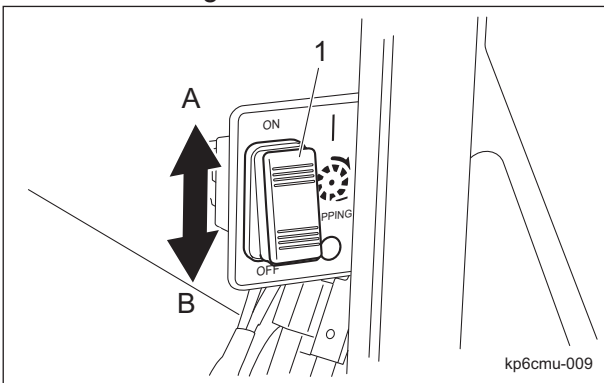

Reel Reverse Switch_001

1	Reel reverse switch
A	Reverse rotation
B	Normal rotation

Reel Rotation/Stop Switching Lever

Caution

Before operating the reel rotation/stop switching lever, be sure to shift the reel rotation switch to the "Stop" position.

The reel rotation/stop switching lever is located on the reel motor attached to each mower unit. It is used during cutting and back lapping. You must shift only the lever(s) for the mower unit(s) that you plan to use for cutting or back lapping to the "Rotate" position. Leave the lever(s) for other mower units in the "Stop" position.

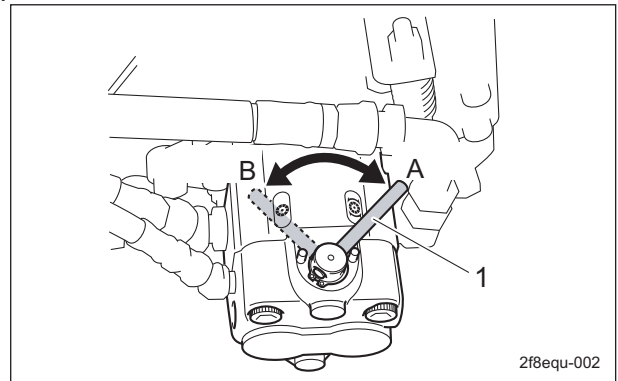

Reel Rotation/Stop Switching Lever_001

1	Reel rotation/stop switching lever
A	Rotate
B	Stop

Traveling Pedal

The traveling pedal is located in the right foot area. When the forward side depressed, the machine travels forward. When the backward side depressed, the machine travels backward.

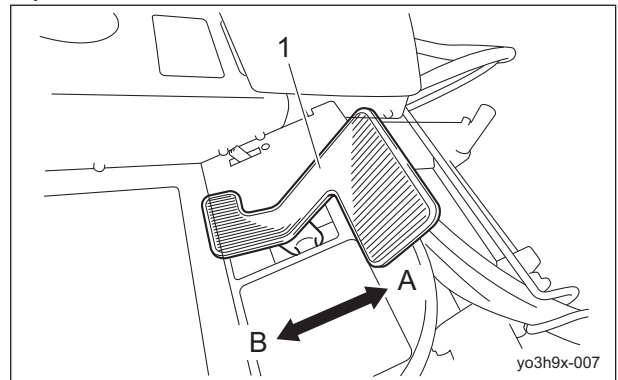

Traveling Pedal_001

1	Traveling pedal
A	Forward
B	Backward

Handling Instructions

Pedal Stopper

The pedal stopper is located in the right foot area.
 This lever changes the amount that the forward pedal can be depressed.
 Be sure to set the pedal stopper to the "Working" position during operation.

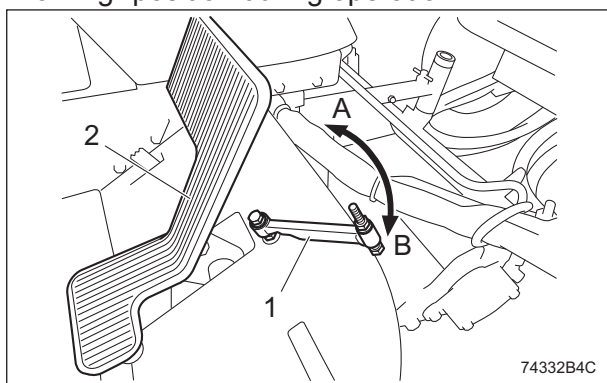

Pedal Stopper_001

1	Pedal stopper
2	Traveling pedal
A	Working
B	Traveling

Brake Pedal

The brake pedal is located in the left foot area.
 To stop the machine, depress the brake pedal all the way firmly.

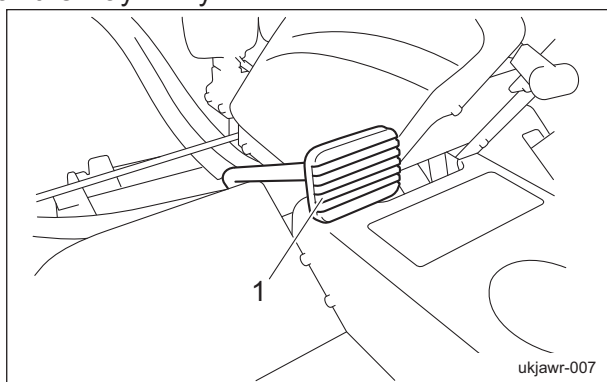

Brake Pedal_001

1	Brake pedal
---	-------------

Parking Brake Lock Lever

Caution

Never park the machine on a slope.

Important

Be sure to release the parking brake before traveling.
 Otherwise, the brake and hydraulic systems will malfunction.

The parking brake lock lever is located in the right foot area.
 When parking, depress the brake pedal and move the parking brake lock lever forward.
 To release the parking brake, depress the brake pedal.

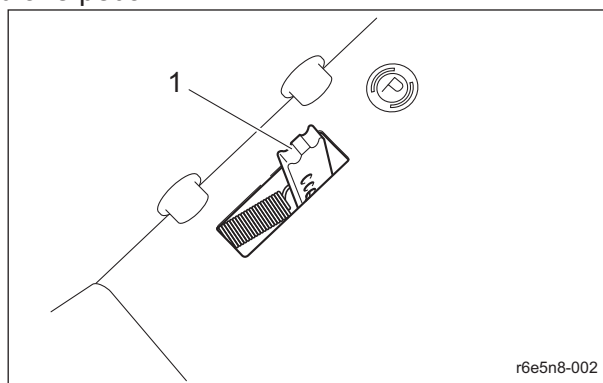

Parking Brake Lock Lever_001

1	Parking brake lock lever
---	--------------------------

Handling Instructions

Hood

⚠ Caution

Do not open the hood in strong winds.

⚠ Caution

Be careful not to pinch your fingers when you open or close the hood.

1. Remove the pin, then the washer.

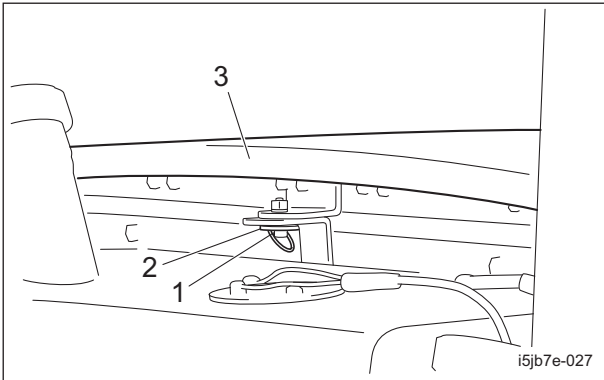

Hood_001

1	Pin
2	Washer
3	Hood

2. Lift up the hood.

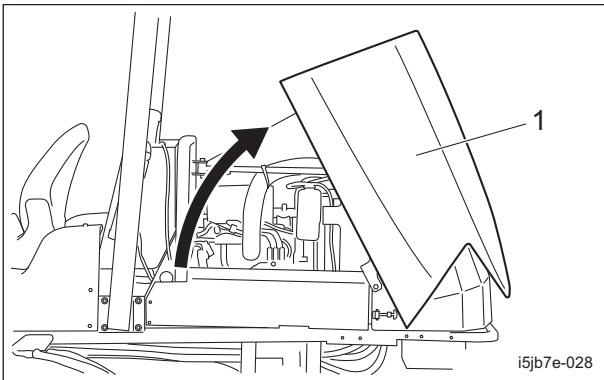

Hood_002

1	Hood
---	------

3. When closing the hood, do the operation slowly.

4. Insert the washer, then the pin.

Underseat Cover

⚠ Caution

Be careful not to pinch your fingers when you open or close the underseat cover.

1. Bring the seat to the most front position.
2. Remove two bolts located on the rear of the seat.

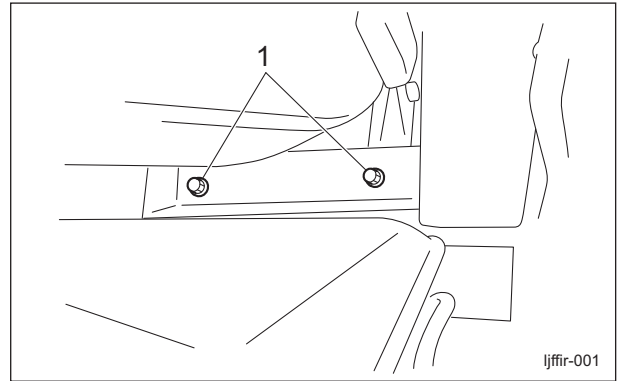

Underseat Cover_001

1	Bolt
---	------

3. Bring the seat to the backmost position.
4. Lift the seat.
Securely support the underseat cover with the seat support rod.

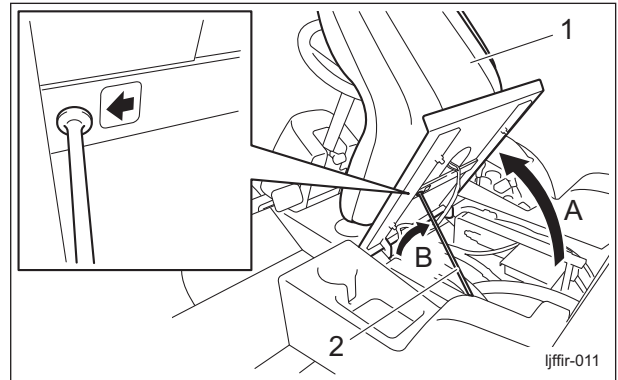

Underseat Cover_002

1	Seat
2	Seat support rod
A	Step 1
B	Step 2

Handling Instructions

Instruments

Instruments on the Operation Panel

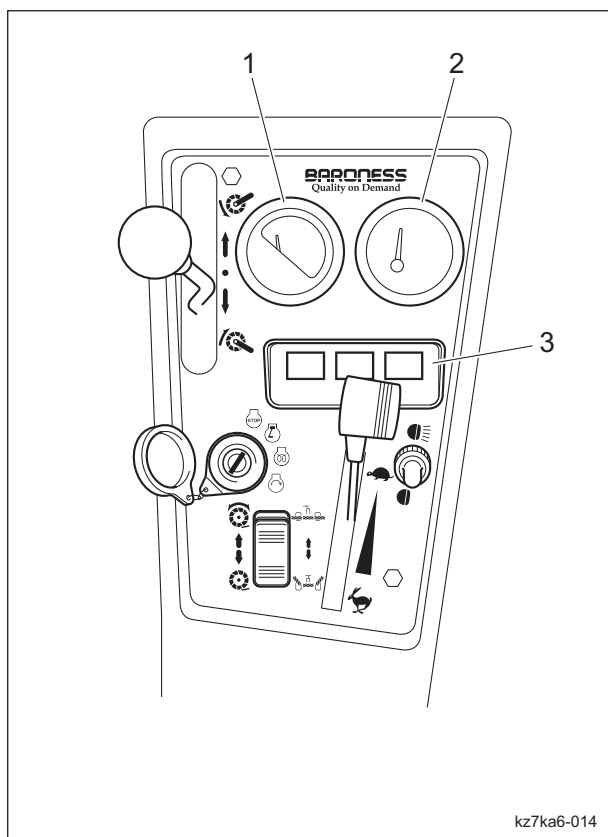

Instruments on the Operation Panel_001

1	Water temperature gauge
2	Fuel gauge
3	Pilot lamps (charge lamp, thermo-start lamp, oil pressure lamp)

Water Temperature Gauge

The water temperature gauge is located in the operation panel.

This instrument indicates the water temperature inside the engine.

If the water temperature gauge indicates a level close to "H" during operation, the machine is overheated.

Remove the load from the engine, idle the machine for five minutes, stop the engine, and then inspect the machine and perform any necessary maintenance.

If the water temperature exceeds 105 °C (221 °F), a buzzer will sound. (Intermittent tone)

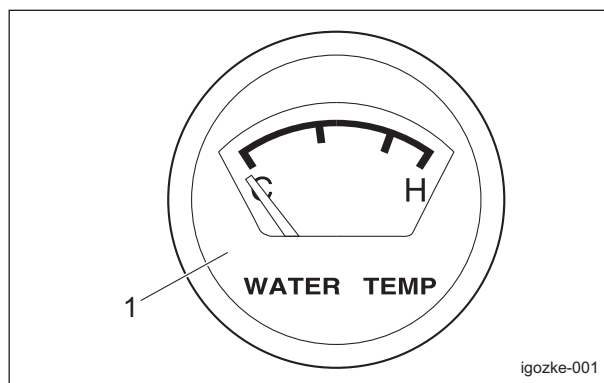

Water Temperature Gauge_001

1	Water temperature gauge
---	-------------------------

Fuel Gauge

The fuel gauge is located in the operation panel.

This instrument indicates the quantity of fuel inside the fuel tank.

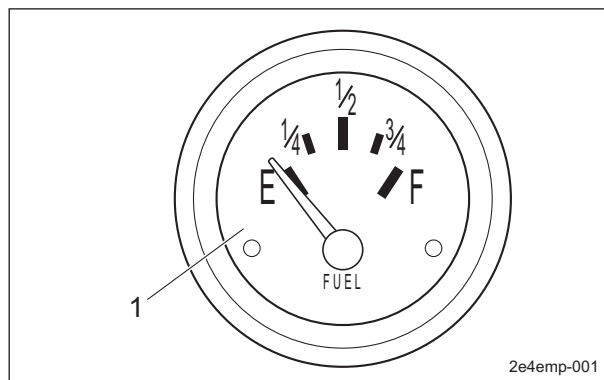

Fuel Gauge_001

1	Fuel gauge
---	------------

Handling Instructions

Pilot Lamps

Charge Lamp

The charge lamp is the left pilot lamp located in the operation panel. It turns on when the ignition key is set to the "ON" position before the engine starts. It turns off when the engine starts and the alternator starts operating properly. If this lamp illuminates while you are operating the machine, stop the engine immediately, and then inspect the machine and perform any necessary maintenance.

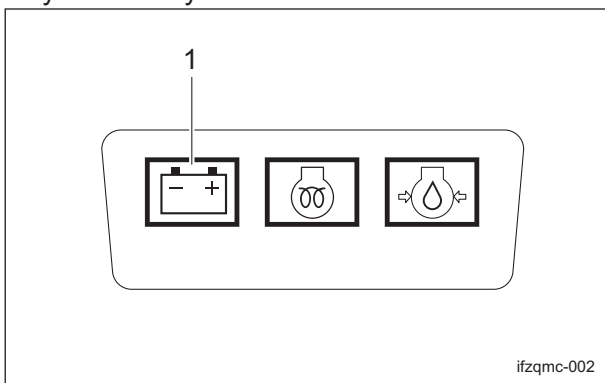

Charge Lamp_001

1	Charge lamp
---	-------------

Oil Pressure Lamp

The oil pressure lamp is the right pilot lamp located in the operation panel. It turns on when the ignition key is set to the "ON" position before the engine starts. It turns off when the engine starts and engine oil pressure is generated properly. If this lamp illuminates while you are operating the machine, stop the engine immediately, and then inspect the machine and perform any necessary maintenance.

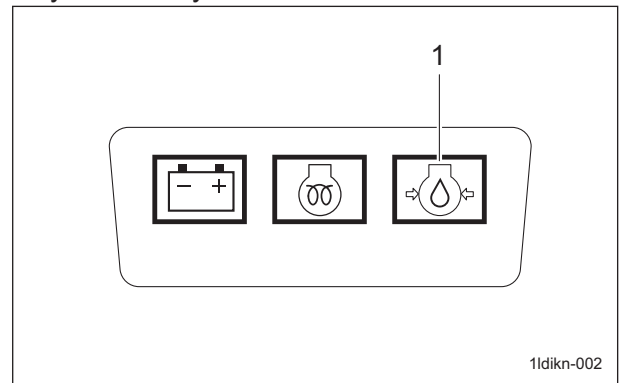

Oil Pressure Lamp_001

1	Oil pressure lamp
---	-------------------

Thermo-Start Lamp

The thermo-start lamp is the middle pilot lamp located in the operation panel. When the ignition key is set to the "GLOW" position, it illuminates as the glow plug generates heat. Illumination of the thermo-start lamp is controlled by the glow lamp timer, and the lamp is turned off after a specified amount of time passes. The duration of illumination indicates an approximate period of time required for warm-up, and has been fixed at five seconds.

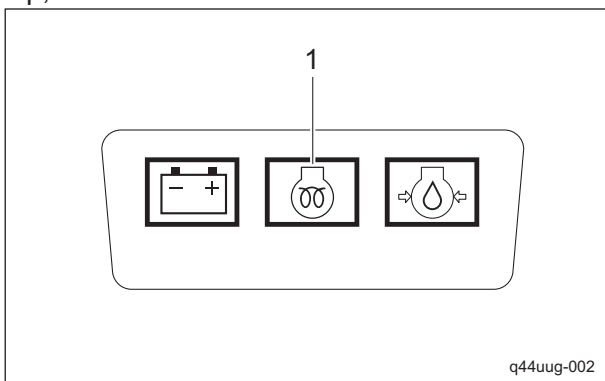

Thermo-Start Lamp_001

Overheat Warning Buzzer

If the water temperature inside the engine exceeds 105 °C (221 °F), a buzzer will sound. (intermittent tone) Remove the load from the engine, idle the machine for five minutes, stop the engine, and then inspect the machine and perform any necessary maintenance.

Handling Instructions

Hour Meter

The hour meter indicates the accumulated operation time of the engine.

The number in red figures on a white background is incremented every thirty-six seconds.

The number in white figures on a black background is incremented every hour.

1/100 wheel ... red figures on a white background

Hour wheel ... white figures on a black background

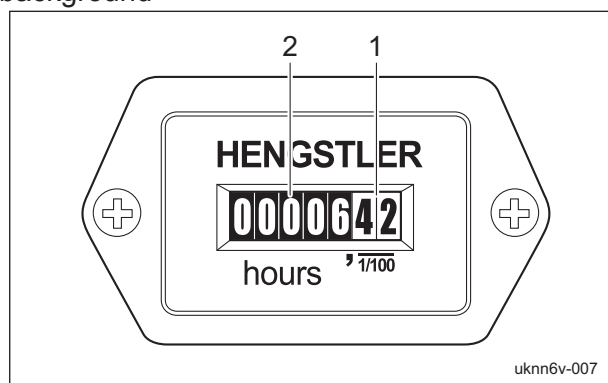

Hour Meter_001

1	1/100 wheel
2	Hour wheel

Move

Traveling Procedure

Caution

Under any circumstances drive the machine at such a speed that you can stop it immediately for emergencies.

Important

Do NOT start to move or stop the machine abruptly. It will damage the hydraulic system or result in oil leakage.

1. Start the engine.
"Procedure to Start Engine" (Page 4-20)
2. Make sure that all the mower units are raised.
3. Make sure that the anti-falling stop valve is set to the "Stop" position.
4. Make sure that the mower lock levers (latches) for mower units #4 and #5 are engaged.

5. Depress the brake pedal to release the parking brake.
6. Slowly depress the traveling pedal.
7. The machine starts traveling.
8. Release the traveling pedal and depress the brake pedal to stop the machine.

Towing the Machine

If the machine does not travel due to engine trouble, etc., you can move it in the following ways:

Caution

Before restarting the engine, be sure to tighten the unload valve.

Important

Do not touch the unload valve except when towing the machine.

Important

When towing the machine, travel at a speed no more than 3.0 km/h.

In addition, do not tow the machine for more than 3 minutes.

If the towing speed is too fast or the machine is towed too much, the pump or motor will be damaged.

Important

Do not loosen the unload valve three turns or more.

1. Stop the engine.
"Procedure to Stop Engine" (Page 4-21)
2. Apply the parking brake.
3. Chock the wheels.

Handling Instructions

4. Secure the machine with ropes.

Front side

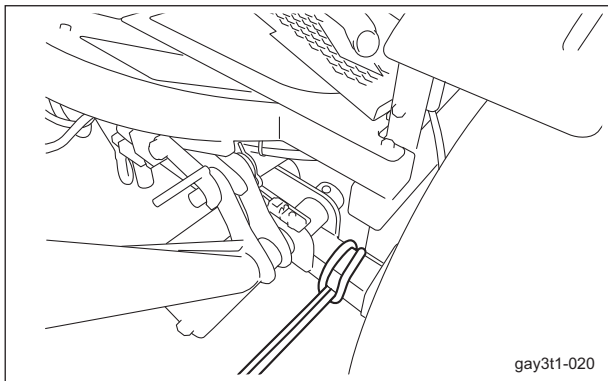

gay3t1-020

Towing the Machine_001

Rear side

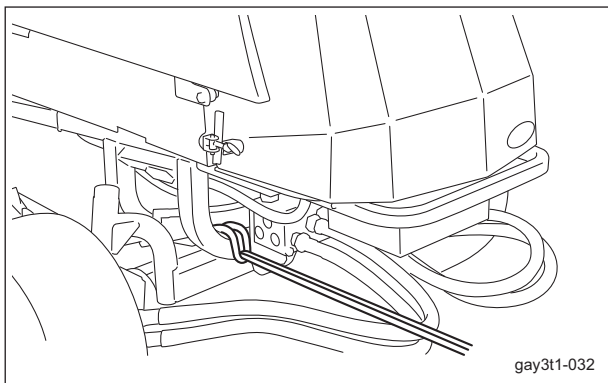

gay3t1-032

Towing the Machine_002

5. Lift up the underseat cover.

"Underseat Cover" (Page 4-32)

6. Rotate the unload valve under the seat 1 to 1.5 turns counterclockwise.

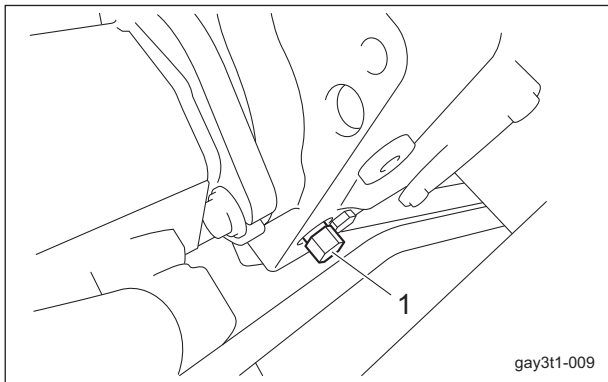

gay3t1-009

Towing the Machine_003

1	Unload valve
---	--------------

7. Close the underseat cover.

8. Remove the wheel stoppers.

9. Depress the brake pedal to release the parking brake.

Warning

While towing, always keep your foot on the brake pedal and depress the brake pedal at any time to stop.

10. Tow the machine slowly.

Cutting Work

Cutting Operation

Caution

Cutting work must be performed at an appropriate speed for the site and location. When cutting bumpy surfaces, keep the engine rpm steady, and slow down the cutting speed.

Caution

Please note that if you stop operating the mower unit up/down lever before the mower units are raised completely, reel rotation may not stop. Reel rotation will be turned on or off based on the sensor-detected position of the mower units.

Important

Perform cutting work with the mower unit up/down lever shifted to the "DOWN" position. Reel rotation will be turned off if the mower unit up/down lever shifted to the "NEUTRAL" or "UP" position.

Important

Do NOT start to move or stop the machine abruptly. It will damage the hydraulic system or result in oil leakage.

1. Shift the reel rotation/stop switching levers of all mower units to the "Rotate" position.
2. Start the engine.
"Procedure to Start Engine" (Page 4-20)
3. Depress the brake pedal to release the parking brake.

Handling Instructions

4. Shift the throttle lever to the "High speed" position, and rev up the engine to MAX.
5. Right before starting cutting work, set the anti-falling stop valve to the "Open" position.
6. Release the mower lock levers (latches) for mower units #4 and #5.
7. Shift the mower unit up/down lever to the "DOWN" position to lower the mower units.
8. Set the reel rotation switch to the "Rotate" position to rotate the reel cutters (cutting cylinders) for all mower units.
9. Depress the traveling pedal to start cutting work.

Removal/Installation of Grass Catcher

⚠ Caution

Stop the engine before removing or installing the grass catcher.

1. Set the reel rotation switch to the "Stop" position.
2. Lower the mower units.
3. Apply the parking brake.
4. Stop the engine.

5. Remove or install the grass catcher.

Removal of grass catcher:

Lift up the grass catcher, and remove the mounting pins on the left and right of the grass catcher from the grass catcher mounting brackets.

Installation of grass catcher:

Install the mounting pins on the left and right sides of the grass catcher into the grass catcher mounting brackets.

Mower units #2 & 3

Note :

The illustration shows the mower unit #3. Right and left positions of the grass catcher mounting brackets differ according to the location of a mower unit.

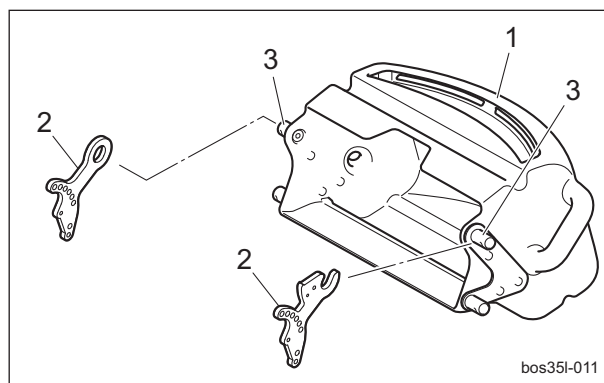

Removal/Installation of Grass Catcher_001

1	Grass catcher
2	Grass catcher mounting bracket
3	Mounting pin

Mower units #1, 4 & 5

Note :

The illustration shows the mower units #1 & 5. Right and left positions of the grass catcher mounting brackets differ according to the location of a mower unit.

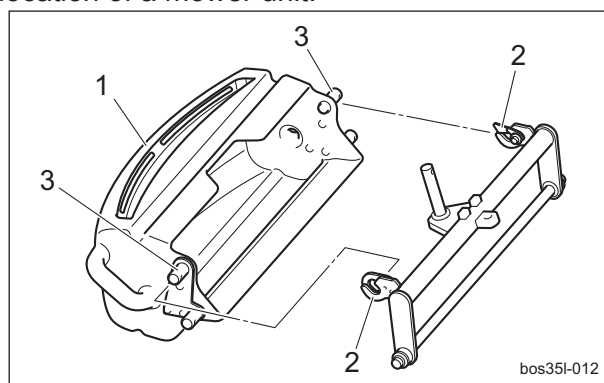

Removal/Installation of Grass Catcher_002

1	Grass catcher
2	Grass catcher mounting bracket
3	Mounting pin

Transporting

Transporting Procedure

When loading this machine into a trailer or a truck to transport it, drive the machine in reverse. When unloading, drive the machine forward.

If the roof is installed on the machine, remove it.

The roof may be damaged by wind pressure.

Handling Instructions

Storage

Before Long-Term Storage

- Remove dirt, grass clippings, debris, oil stains etc. completely.
- Supply oil and apply grease to appropriate parts.
- Remove the negative terminal of the battery.

Maintenance Precautions	Page 5-2
Maintenance Schedule	Page 5-3
Adjusted Value	Page 5-7
Jacking Up The Machine	Page 5-8
About Jacking Up The Machine	Page 5-8
Jack-Up Points	Page 5-8
Greasing	Page 5-9
About Greasing	Page 5-9
Greasing Points	Page 5-9
Lubrication	Page 5-12
About Lubrication	Page 5-12
Lubricating Points	Page 5-12
Maintenance Work	Page 5-13
Removing/Installing Tires	Page 5-13
Adjustment of Belt Tension	Page 5-14
Adjustment of Parking Brake	Page 5-14
Adjustment of Brake	Page 5-15
Adjusting the Neutral Position of the Piston Pump	Page 5-16
Change of Coolant	Page 5-17
Change of Hydraulic Oil Filter	Page 5-18
Change of Hydraulic Oil	Page 5-20
Change of Air Cleaner	Page 5-21
Change of Engine Oil	Page 5-21
Change of Engine Oil Filter	Page 5-22
Change of Fuel Filter Element	Page 5-23
Change of Fuse	Page 5-24

Maintenance

Maintenance Precautions

Warning

The chapter "Maintenance" in this manual describes practical measures which should be performed by a mechanic with expertise. The owner should instruct the mechanic with expertise to perform maintenance service for this machine.

Caution

First, learn well the maintenance operations you plan to perform.

Important

Use tools appropriate for each maintenance operation.

Important

For the safe and best performance of your machine, use Baroness genuine parts for replacement and accessories. Please note that our product warranty may be void if you use non-genuine parts for replacement or accessories.

Maintain the machine according to the maintenance schedule so that you will be able to take advantage of its optimum performance for a long period of time.

Maintenance Schedule

LM531

Follow the maintenance schedule below.

○ . . . Inspect, adjust, supply, clean

● . . . Replace (first time)

△ . . . Replace

Maintenance Item		Before Work	After Work	Every Week	Every 50 hrs.	Every 100 hrs.	Every 200 hrs.	Every 250 hrs.	Every 400 hrs.	Every 500 hrs.	Every 800 hrs.	Every 1000 hrs.	Every 1500 hrs.	Every 3000 hrs.	every month	Every year	Every 2 years	Every 4 years	When Required	Remarks
*3	Check engine oil level and contamination	○																		
*3	Check fuel level	○																		
*3	Check coolant level	○																		
*3	Check fan belt	○																		
	Check hydraulic oil level	○																		
	Check hydraulic hoses condition (Moving part)	○																		
	Check tire pressures and condition	○																		
	Check cover condition	○																		
	Check traveling pedal motion	○																		
	Check brake function	○																		
	Check brake wire	○																		
	Check brake pedal play	○																		
	Check oil or water leaks	○																		
	Check damaged parts	○																		
	Check tightening bolts and nuts	○																		
	Check light illumination	○																		
	Check meters and lamps	○																		By starting the engine
	Check interlock system safety function	○																		By starting the engine

Maintenance

Maintenance Item		Before Work	After Work	Every Week	Every 50 hrs.	Every 100 hrs.	Every 200 hrs.	Every 250 hrs.	Every 400 hrs.	Every 500 hrs.	Every 800 hrs.	Every 1000 hrs.	Every 1500 hrs.	Every 3000 hrs.	every month	Every year	Every 2 years	Every 4 years	When Required	Remarks
	Clean radiator screen		○																	
	Clean radiator core		○																	
	Clean oil cooler core		○																	
	Clean machine exterior		○																	
	Clean engine area		○																	
	Grease and Lubricate all moving parts				○															
*3	Check fuel hoses and clamp bands				○															
*3	Check electrical wiring condition (Damage, defacement and joint looseness)				○	○														50 hours first check, every 100 hours thereafter
	Check looseness of wheel mounting bolt				○	○														50 hours first check, every 100 hours thereafter
*3.*5	Change engine oil				●	△														50 hours first check, every 100 hours thereafter
*2	Replace oil filter cartridge				●		△													50 hours first check, every 200 hours thereafter
	Replace hydraulic oil					●			△											100 hours first change, every 500 hours thereafter
*2	Clean air cleaner element (Replace the element after 6-time cleaning)					○										△				Replace every 6 cleanings or every year whichever comes earlier Air cleaner should be cleaned more often in dusty conditions than

Maintenance

Maintenance Item		Before Work	After Work	Every Week	Every 50 hrs.	Every 100 hrs.	Every 200 hrs.	Every 250 hrs.	Every 400 hrs.	Every 500 hrs.	Every 800 hrs.	Every 1000 hrs.	Every 1500 hrs.	Every 3000 hrs.	every month	Every year	Every 2 years	Every 4 years	When Required	Remarks
*2	Clean air cleaner element (Replace the element after 6-time cleaning)					○										△				in normal conditions
*3	Check cracks in cooling fan					○														
	Draining of water separator					○														
*3	Adjust fan belt tension				○	○														50 hours first change, every 100 hours thereafter
*4	Check exterior of battery					○									○					Check every 100 hours or every month whichever comes earlier
*4	Clean exterior of battery					○									○					Check every 100 hours or every month whichever comes earlier
*4	Check mounting bracket of battery					○									○					Check every 100 hours or every month whichever comes earlier
*4	Check looseness and corrosion of battery terminals					○									○					Check every 100 hours or every month whichever comes earlier
*3	Check battery fluid level					○									○					Check every 100 hours or every month whichever comes earlier
	Replace hydraulic oil filter					●				△										100 hours first change, every 500 hours thereafter
	Replace hydraulic suction filter					●				△										100 hours first change, every 500 hours thereafter

Maintenance

Maintenance

Maintenance Item		Before Work	After Work	Every Week	Every 50 hrs.	Every 100 hrs.	Every 200 hrs.	Every 250 hrs.	Every 400 hrs.	Every 500 hrs.	Every 800 hrs.	Every 1000 hrs.	Every 1500 hrs.	Every 3000 hrs.	every month	Every year	Every 2 years	Every 4 years	When Required	Remarks
	Check hydraulic hoses condition (Fixed part)						○									○				Check every 200 hours or every year whichever comes earlier
*3	Check radiator hoses and clamp bands						○													
*2	Check intake air line (air cleaner hose)						○													
	Check closed breather hoses						○													
	Grease mower unit hydraulic motor shafts							○												
*3	Clean water separator								○											
*3	Replace fuel filter cartridge								△											
*3	Clean water jacket and radiator interior									○										
*3	Clean fuel tank interior									○										
*3	Replace fan belt									△							△			Replace every 500 hours or 2 years whichever comes earlier
	Replace antivibration rubber for engine											△						△		Replace every 1000 hours or 4 years whichever comes earlier
	Adjust valve clearance										○									
*1.*2	Check injection nozzle												○							
*1.*2	Check injection pump													○						
	Replace hydraulic hoses (Moving part)																	△		
*6	Replace hydraulic hoses (Moving part) relating to steering																	△		

Maintenance

Maintenance Item		Before Work	After Work	Every Week	Every 50 hrs.	Every 100 hrs.	Every 200 hrs.	Every 250 hrs.	Every 400 hrs.	Every 500 hrs.	Every 800 hrs.	Every 1000 hrs.	Every 1500 hrs.	Every 3000 hrs.	every month	Every year	Every 2 years	Every 4 years	When Required	Remarks
*3	Replace radiator hoses and clamp bands																△			
	Replace fuel hoses and clamps																△			
	Replace intake air line (air cleaner hose)																△			
	Replace closed breather hoses																△			
*3	Change radiator coolant (L.L.C.)																△			
*3	Replace battery																△			
	Replace hydraulic hoses (Fixed part)																	△		
	Adjust brake cables																		○	
	Replace brake cables																		△	
	Replace cables for traveling																		△	
	Replace brake pads																		△	

Maintenance

- *1: Consult your local Barones Dealer or local KUBOTA Dealer for this service.
- The items above (*2 marked) are registered as emission related critical parts by KUBOTA in the U.S. EPA nonroad emission regulation.
As the engine owner, you are responsible for the performance of the required maintenance on the engine according to the above instruction.
Please see the Engine's Warranty Statement in detail.
- *3: Refer to the Engine's Owner's Manual.
- *4: Refer to the Battery's Owner's Manual.
- *5: The replacement period of engine oil is scheduled shorter than the engine factory-recommended period according to the features of this machine.
- The values for consumables are not guaranteed.
- *6: Be sure to replace hydraulic hoses for steering cylinder and hydraulic hoses for hydraulic motor of wheel relating to steering every two years.

Adjusted Value

Fan belt	10 mm (0.39 in)	Belt slack
----------	-----------------	------------

Maintenance

Jacking Up The Machine

About Jacking Up The Machine

Warning

When replacing a tire or beginning any other maintenance or repairs, be sure to chock the wheels to prevent the machine from moving. Before jacking up the machine, park it on a hard, flat surface such as a concrete floor and remove any obstacles that could prevent you from performing the work safely. When necessary, use an appropriate chain block, hoist, or jack. Support the machine securely with jack stands or appropriate blocks. Failure to do so may cause the machine to move or fall, resulting in injury or death.

Important

Only place a jack under the jack-up points specified. Placing a jack at any other point will result in damage to the frame or other parts.

Use the jack-up points identified in this manual when jacking up the machine.

Jack-Up Points

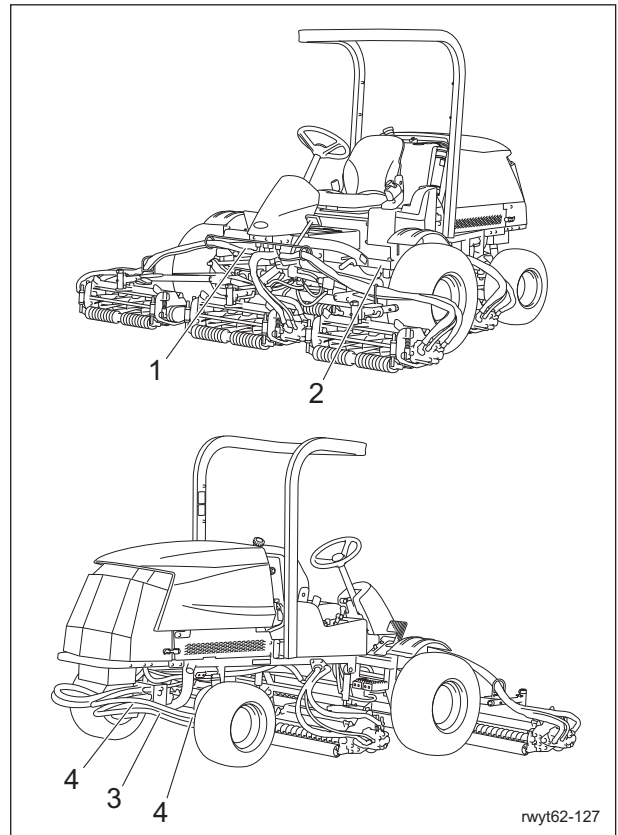

Jack-Up Points_001

	Jack-up Points
1	Front right frame
2	Front left frame
3	Rear frame
4	Pivot

1. Front right frame

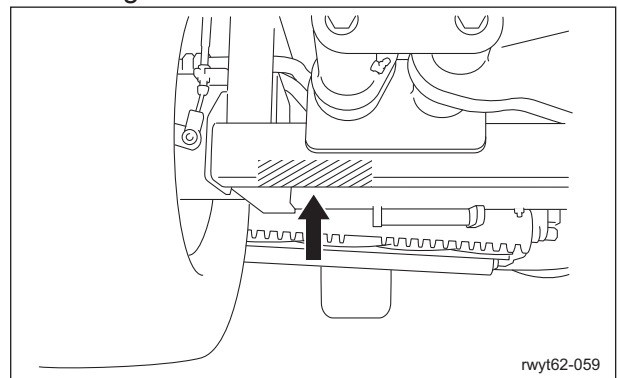

Jack-Up Points_002

2. Front left frame

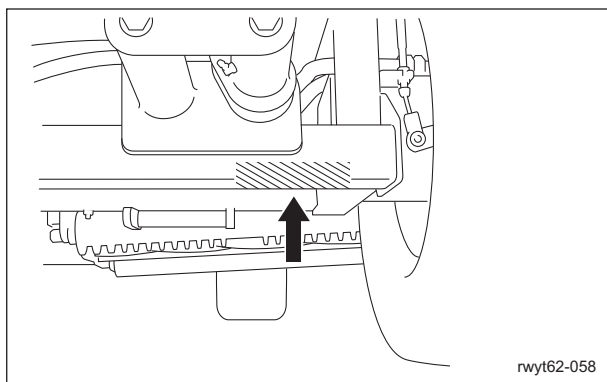

Jack-Up Points_003

3. Rear frame

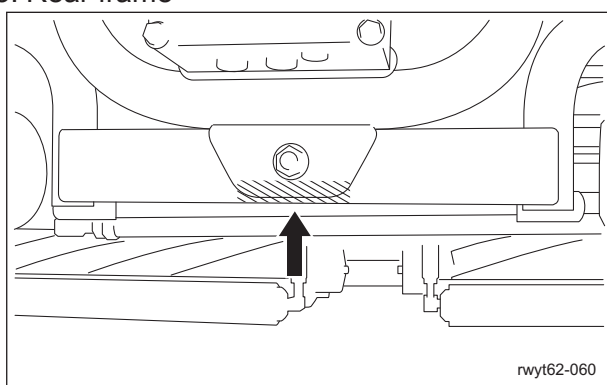

Jack-Up Points_004

4. Pivot

There are two locations.

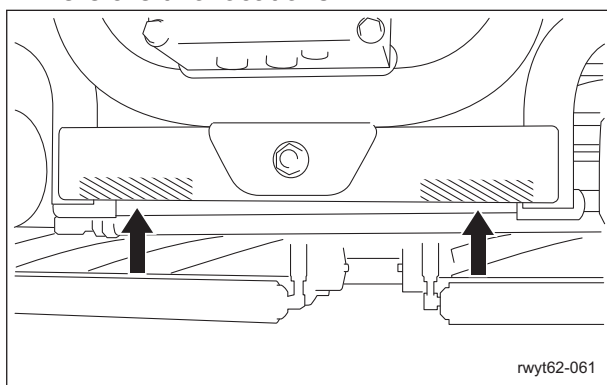

Jack-Up Points_005

Other locations where the specified grease or lubricant is used are indicated in "Greasing Points".

Add grease using the specified grease or lubricant.

Greasing Points

Grease nipples are installed in the following locations.

Add grease every 50 hours of operation. If specified locations, periods and grease are additionally described below, follow the instructions.

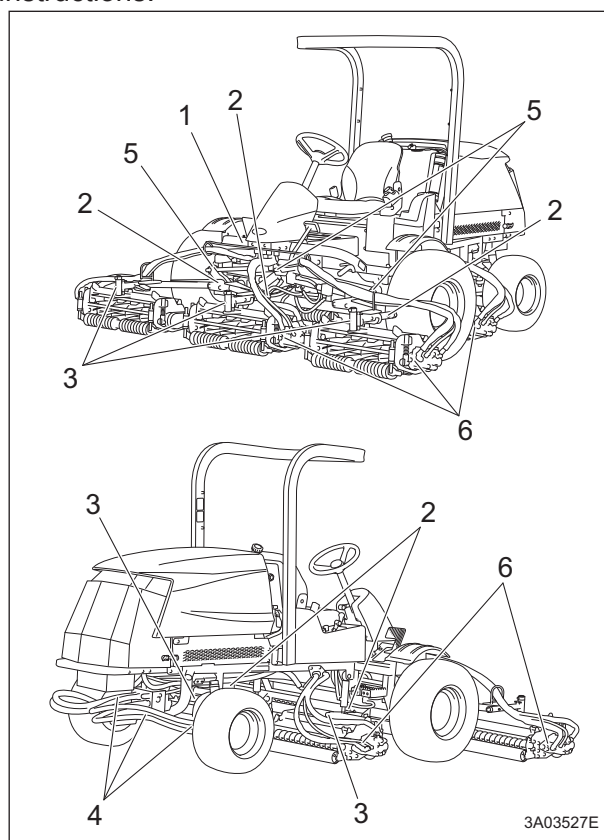

Greasing Points_001

	Location	No. of greasing points
1	Pedal shaft fulcrum	2
2	Lift arm fulcrum	5
3	Mower unit fulcrum	5
4	Pivot	3
5	Cylinder shaft	4
6	Reel motor shaft	5

Greasing

About Greasing

Since there may be adhesion or damage due to lack of grease on moving parts, they must be greased.

Add urea-based No. 2 grease in accordance with the Maintenance Schedule.

Maintenance

1. Pedal shaft fulcrum

There are two greasing points.

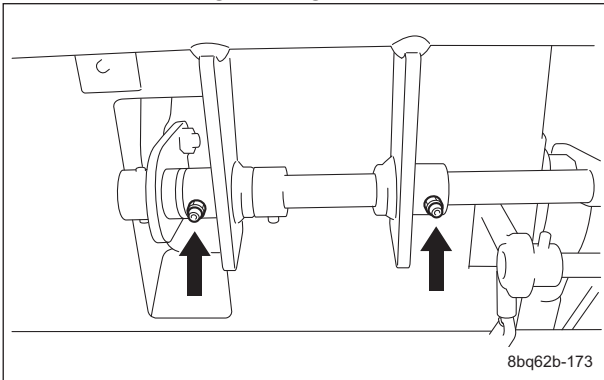

Greasing Points_002

2. Lift arm fulcrum

There is one greasing point on each lift arm fulcrum connected to the mower unit.
Before greasing a lift arm fulcrum, lower the mower unit.

Mower units #1 and 4

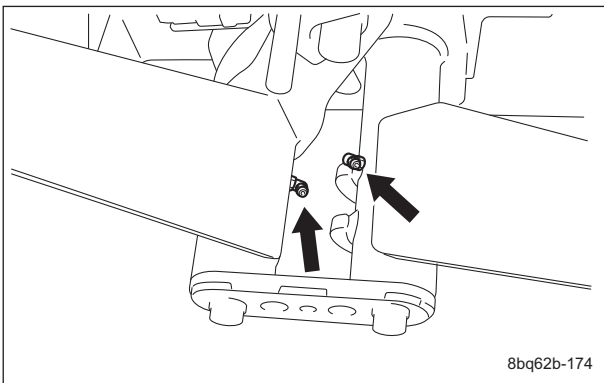

Greasing Points_003

Mower unit #5

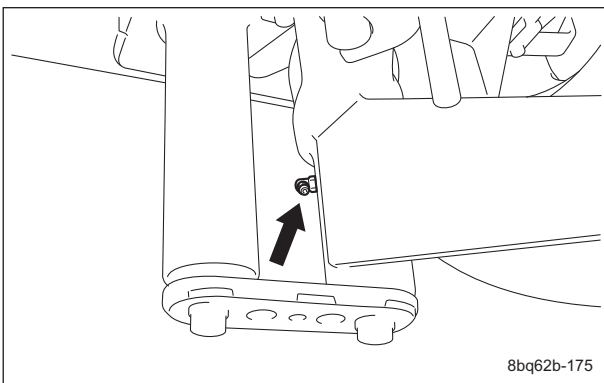

Greasing Points_004

Mower unit #2 and 3

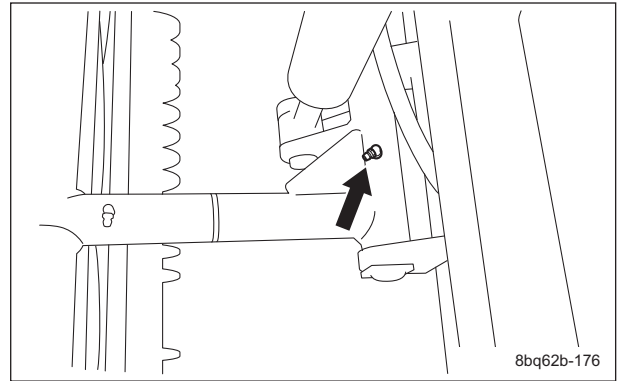

Greasing Points_005

3. Mower unit fulcrum

There is one greasing point on each mower unit.

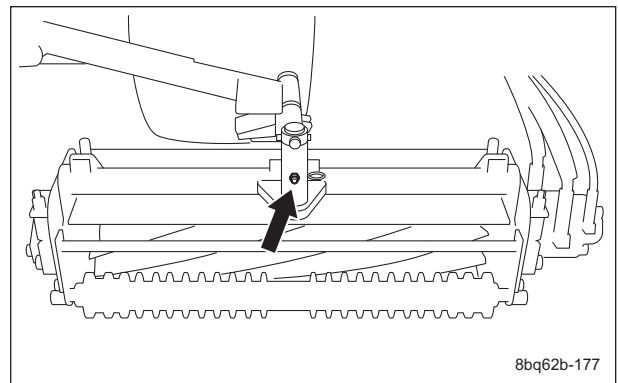

Greasing Points_006

4. Pivot

There are three greasing points.
Middle between rear wheels

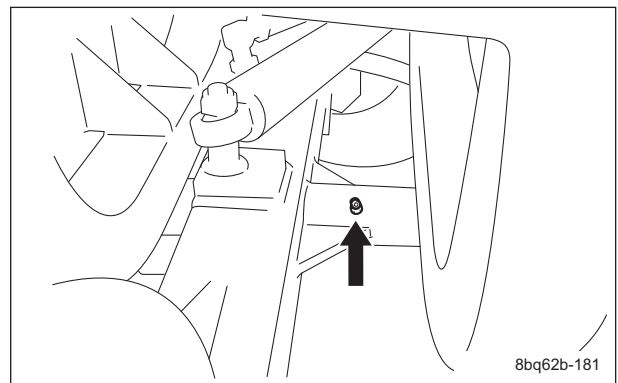

Greasing Points_007

Rear left wheel

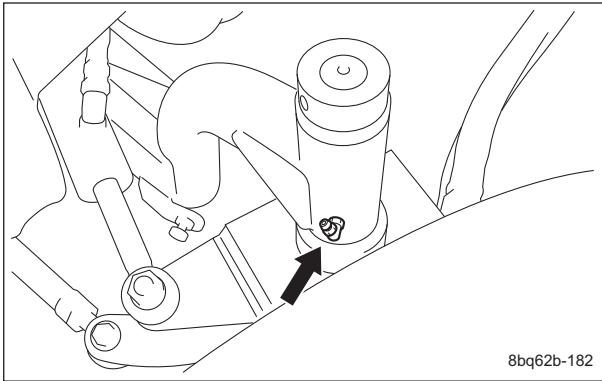

Greasing Points_008

8bq62b-182

Rear right wheel

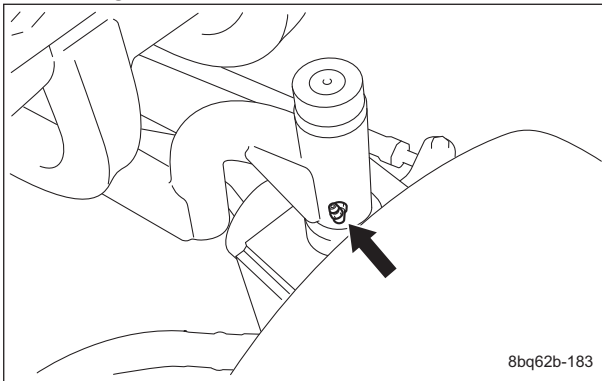

Greasing Points_009

8bq62b-183

5. Cylinder shaft

Cylinder shaft #1

There are two greasing points on the cylinder shaft.

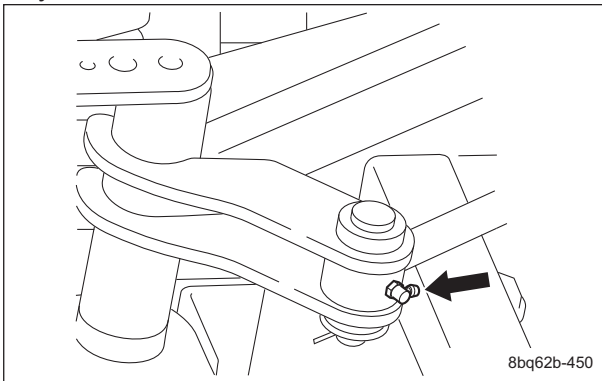

Greasing Points_010

8bq62b-450

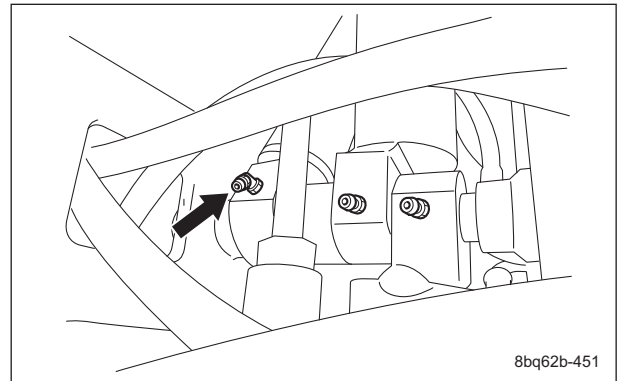

8bq62b-451

Greasing Points_011

Cylinder shafts #4 and 5

There is one greasing point each on the cylinder shafts.

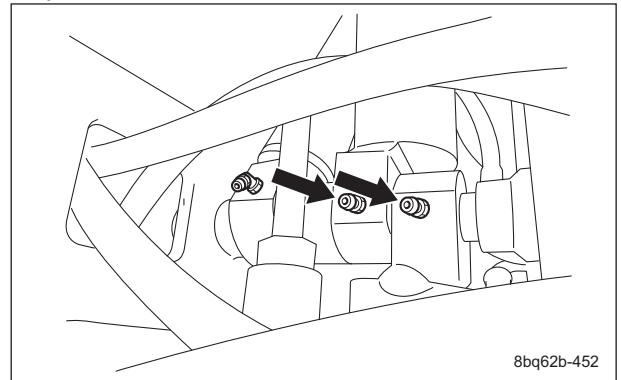

8bq62b-452

Greasing Points_012

6. Reel motor shaft

Apply 2 g (0.004 lb) of MORI SPEED GREASE NO.2 to the reel mower shaft mounted on each mower unit every 250 hours.

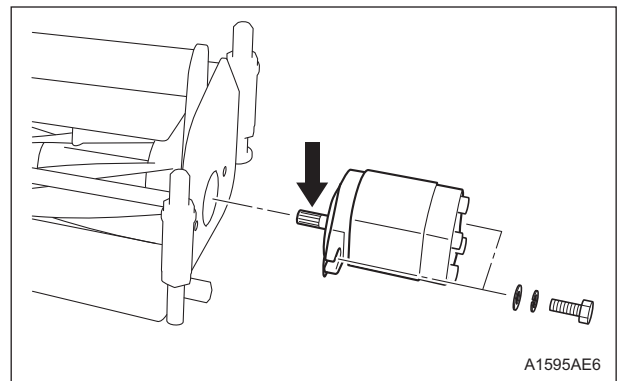

A1595AE6

Greasing Points_013

Maintenance

Lubrication

About Lubrication

It is necessary to lubricate moving parts so that they will not become stuck or damaged. The locations where lubricant is used are indicated in "Lubricating Points". Apply the lubricant.

Lubricating Points

Apply lubricant at the following locations every 50 hours of operation.

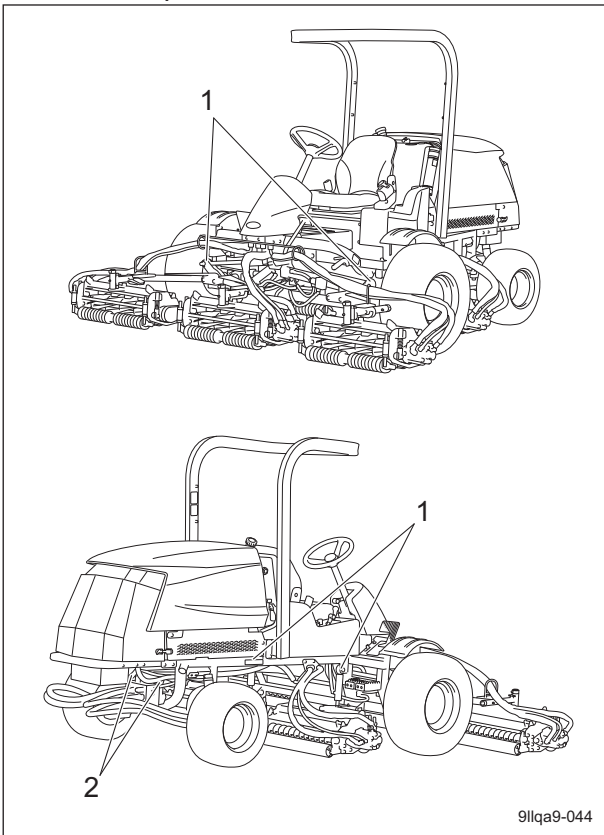

Lubricating Points_001

	Location	No. of greasing points
1	Mower cylinder spherical bearing	4
2	Steering cylinder spherical bearing	2

1. Mower cylinder spherical bearing
There is one point on each mower cylinder. Mower cylinder #2 and 3

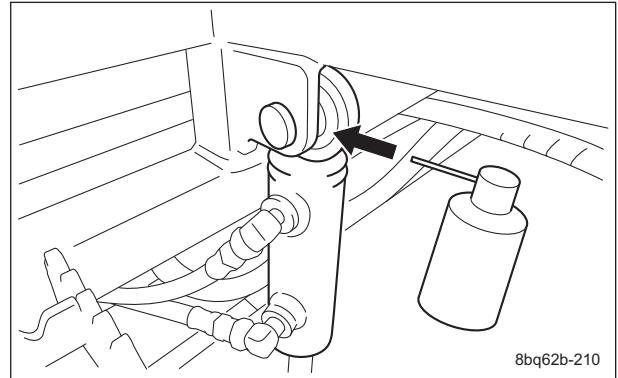

Lubricating Points_002

- Mower cylinder #4 and 5

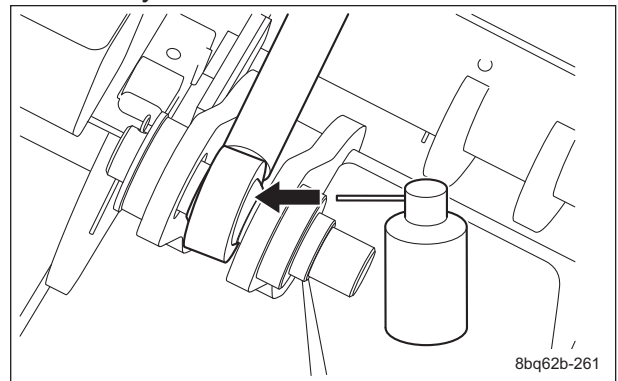

Lubricating Points_003

2. Steering cylinder spherical bearing
Middle between rear wheels

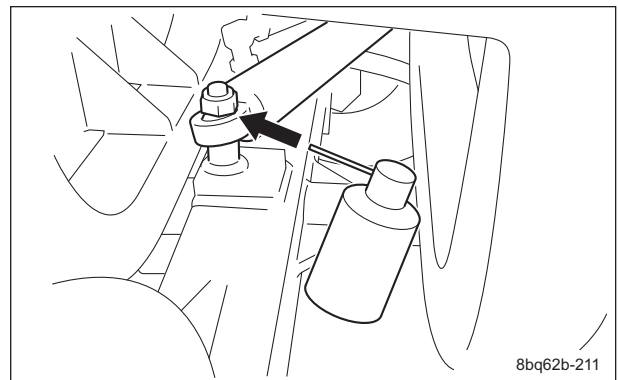

Lubricating Points_004

Rear left wheel

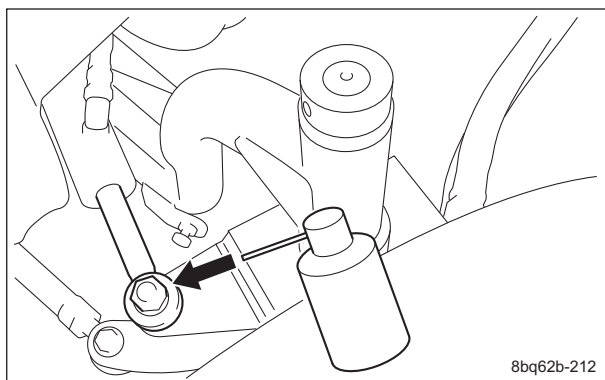

Lubricating Points_005

Maintenance Work

Removing/Installing Tires

Front Tires

Follow the steps below to remove the front tires:

1. Loosen the bolts.

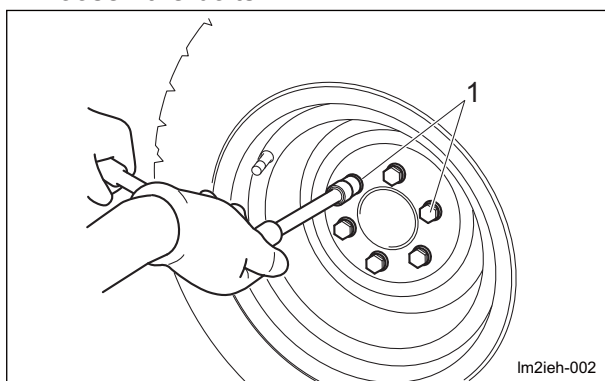

Front Tires_001

1	Heat-treated bolt
---	-------------------

2. Securely place the jack beneath the jack-up point of the front left/right frame area, and then raise it until the tire lifts off the ground. "Jack-Up Points" (Page 5-8)
3. Remove the bolts.
4. Remove the tire from the wheel mounting seat.

Important

Tighten the bolts in the tightening order (diagonally).

For installing the front tires, reverse the removing procedure.

Rear Tire

Follow the steps below to remove the rear tires:

1. Loosen the bolts.

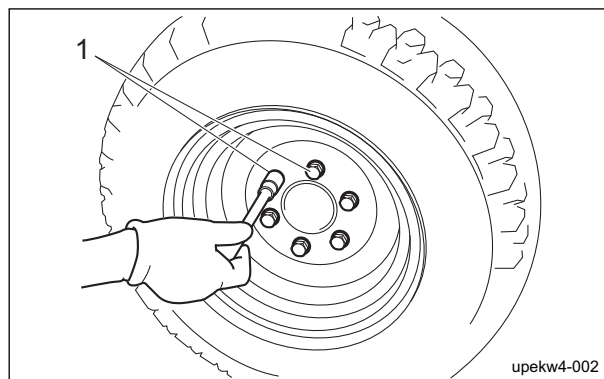

Rear Tire_001

1	Heat-treated bolt
---	-------------------

2. Securely place the jack beneath the jack-up point of the rear frame area, and then raise it until the tire lifts off the ground. "Jack-Up Points" (Page 5-8)
3. Remove the bolts.
4. Remove the tire from the wheel mounting seat.

Important

Tighten the bolts in the tightening order (diagonally).

For installing the rear tires, reverse the removing procedure.

Maintenance

Adjustment of Belt Tension

Warning

Be sure to stop the engine before adjusting the belts.

Important

Before making sure of belt tension, rotate the belt several times.

If the belt becomes slack due to frequent use, it may jump or slip.

In addition, if it is overtightened, it may wear prematurely.

If necessary, adjust it, and always check the belt for appropriate tension.

Fan Belt

1. Press the middle of the belt with your finger to check the belt tension.

The belt tension is appropriate when the belt slacks by approximately 10.0 mm (0.39 in) when you apply a force of 98 N (10 kgf) to the belt at the middle point between the pulleys.

2. If the belt tension is incorrect, loosen bolt A and bolt B (securing the alternator), and then move the alternator to adjust the tension.

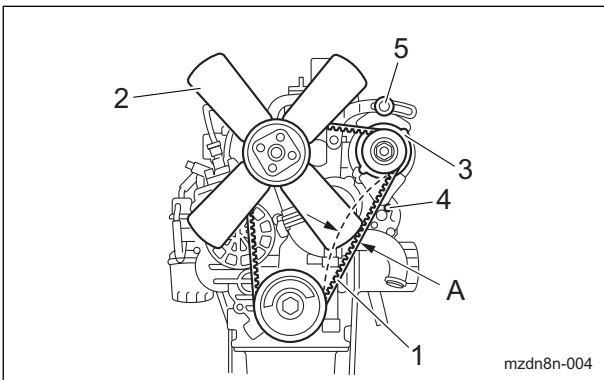

Fan Belt_001

1	Fan Belt
2	Blade
3	Alternator
4	Bolt A
5	Bolt B
A	10 mm (0.39 in)

Adjustment of Parking Brake

Danger

If the brake wire is cut, the machine will be unable to stop. This would be extremely dangerous.

If the brake wire is cracked or damaged, replace it with a new one immediately.

If the brake is not sufficiently effective, adjust the brake wire.

1. Check position of the notch of the parking brake.
2. Depressing the brake pedal firmly, move the parking brake lock lever forward with a foot. Make adjustments with the adjustment bolt inside of the tire so that the latch of the parking brake lock lever is positioned at arrow A (fourth notch from the bottom). "Adjustment of Brake" (Page 5-15)

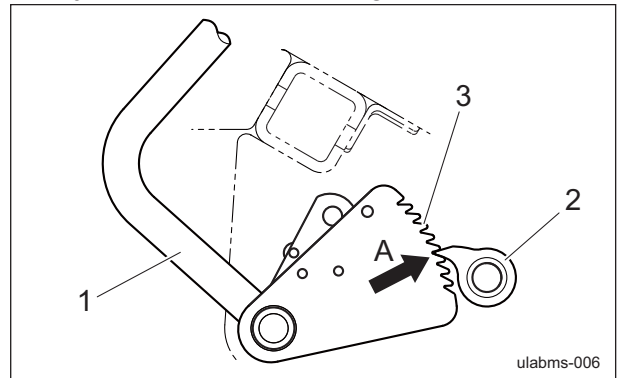

Adjustment of Parking Brake_001

1	Brake pedal
2	Latch
3	Notch

Adjustment of Brake

⚠ Danger

If the brake wire is cut, the machine will be unable to stop. This would be extremely dangerous.
If the brake wire is cracked or damaged, replace it with a new one immediately.
If the brake is not sufficiently effective, adjust the brake wire.

Important

Adjust to reduce the play in the brake lever as much as possible so that the brake does not drag when the lever is released.

- Adjust the brake by tightening the brake wire adjustment bolt.
 - If there is too much play in the brake lever, the braking power is reduced and the brake pedal feel is light.
 - If there is too little play in the brake lever, the braking power is increased and the brake pedal feel is heavy.

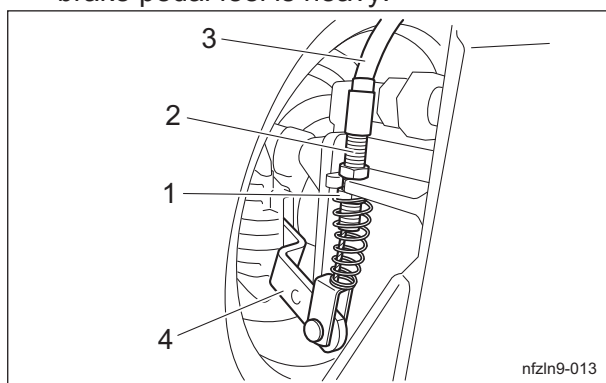

Adjustment of Brake_001

1	Lock nut
2	Adjustment bolt
3	Brake wire
4	Brake lever

- Start the engine and drive to check the following.
 - Make sure that heat is not generated in the brake area.
 - Make sure that the left and right brakes are equally effective.

⚠ Danger

It would be extremely dangerous and may result in an unexpected accident if the left and right brakes are not equally effective.

- If the left and right brakes are not equally effective, make fine adjustments with the adjustment bolt on the brake wire.

Break-In of Brakes

If the brake shoes or brake pads are worn, replace them with new ones.
Immediately after replacement, drive to break in the brakes if the effectiveness of the brakes is low.
While driving, lightly operate the brakes to break in the contact areas.

Maintenance

Adjusting the Neutral Position of the Piston Pump

⚠ Caution

Make sure not to touch rotating tires.

⚠ Caution

When adjusting the neutral position, pay close attention to abrupt start of the machine. Place the jacks beneath the jack-up points, and then lift the machine until all the tires get off the ground.

If the machine moves forward or backward while the traveling pedals are released, they are not set to the neutral position.

Follow the steps below to make adjustments.

1. Stop the engine.
2. Place the jacks beneath the jack-up points, and then lift the machine off the ground. "Jack-Up Points" (Page 5-8)
3. Make sure that no tires get contact with the jack stand.
4. Start the engine, and rev it up to the maximum rpm.
5. Adjust the neutral position.

[1] Loosen the lock nuts.

[2] Rotate the traction adjusting cam slowly until all wheels stop.

- If the tires move in the direction of forward travel, rotate the traction adjusting cam clockwise.
 - If the tires move in the direction of backward travel, rotate the traction adjusting cam counterclockwise.
- Find the position where all tires stop, and then, while holding the traction adjusting cam in place, secure it with the lock nut.

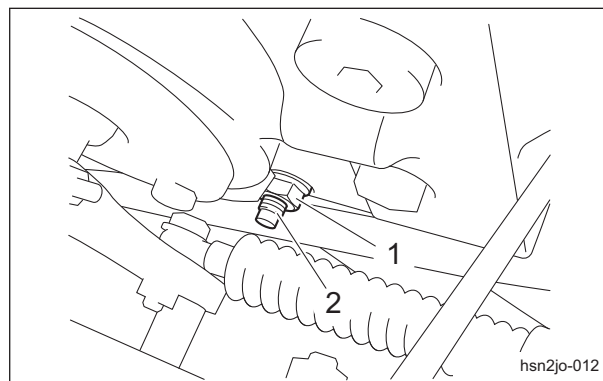

Adjusting the Neutral Position of the Piston Pump_001

1	Lock nut
2	Traction adjusting cam

6. Check that the tires do not move.

Change of Coolant

Caution

Do not touch the radiator or coolant during engine operation or immediately after the engine has been turned off. Otherwise, you may get burned.

Caution

Change coolant after the engine has well cooled down.

Caution

The radiator cap is pressurized. If you remove the radiator cap while the engine is overheated, hot steam will burst out, possibly resulting in burns. Make sure that the water temperature and pressure are reduced, and then grab the cap with a thick cloth and gradually open the cap.

Important

When changing the coolant, be sure to drain it into a container and discard it in accordance with local laws and regulations.

Important

When changing the coolant, be sure to mix clean water (soft water) and antifreeze (long-life coolant), and then pour it into the radiator and reserve tank.

Important

Tightly close the radiator cap. If the cap is loose or incorrectly installed, the engine will be overheated due to water leakage, resulting in engine damage.

When mixing antifreeze and clean water (soft water), refer to "Relationship between concentration of long-life coolant (LLC) and freezing temperature" below for the mixing ratio.

Relationship between concentration of long-life coolant (LLC) and freezing temperature

Freezing temperature	LLC concentration (volume %)
Down to -10 °C (14 °F)	20 %
Down to -15 °C (5 °F)	30 %
Down to -20 °C (-4 °F)	35 %
Down to -25 °C (-13 °F)	40 %

1. Stop the engine, and then allow the radiator to cool.
2. Open the hood.
3. Follow the steps below to drain the coolant.
 - [1] Position a container to drain the coolant into.
 - [2] Loosen the drain cock of the radiator.

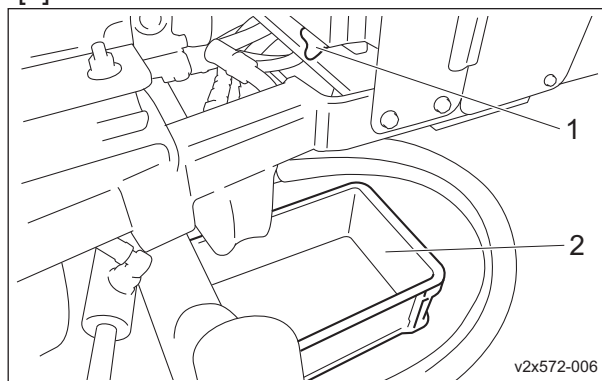

Change of Coolant_001

1	Radiator drain cock
2	Container

- [3] Remove the radiator cap and drain the coolant.

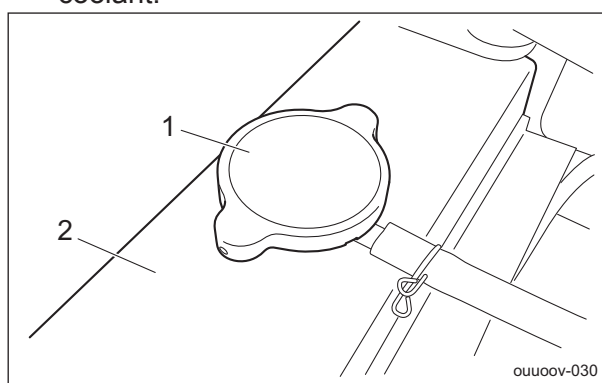

Change of Coolant_002

1	Radiator cap
2	Radiator

Maintenance

[4] Remove the reserve tank.

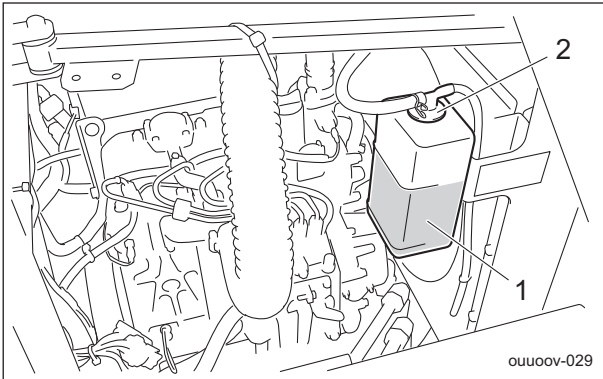

Change of Coolant_003

1	Reserve tank
2	Reserve tank cap

[5] Open the reserve tank cap, and then drain the coolant.

4. Install the reserve tank.
5. Clean the radiator with clean water (soft water) to remove any debris or rust.
6. Drain all water from the radiator.
7. Follow the steps below to fill with coolant. The coolant quantity, including the reserve tank, is 6.0 dm³ (6.0 L).
 - [1] Install the drain plug.
 - [2] Supply clean water (soft water) and antifreeze into the radiator up to the radiator cap opening.
 - [3] Close the radiator cap.
 - [4] Supply clean water (soft water) and antifreeze into the reserve tank up to the "FULL" mark.
 - [5] Close the reserve tank cap.
8. Start the engine, and then idle for several minutes to bleed air from the system.
9. Stop the engine, and then allow the radiator to cool.
10. Check if the coolant level in the reserve tank is between "FULL" and "LOW", and then supply coolant if necessary.
11. Close the hood.

Change of Hydraulic Oil Filter

Change of Hydraulic Oil Line Filter

⚠ Caution

Be careful with hot oil, which could cause burns if it contacts your skin.

Important

When replacing the hydraulic oil filter, be sure to drain the oil into a container and discard it in accordance with local laws and regulations.

Important

If the hydraulic oil emulsifies or if it becomes even slightly less transparent, change the oil immediately.

Important

Use Shell Tellus S2M46 (or equivalent) as hydraulic oil.

1. On a level surface, lower the mower units, and then stop the engine.
2. Remove the old filter cartridge.
3. Lightly coat the packing of the new filter cartridge with hydraulic oil, and then install the cartridge.
4. Firmly tighten the filter cartridge by hand so that the packing contacts the mounting surface. Then, tighten it an additional 1/2 turn.

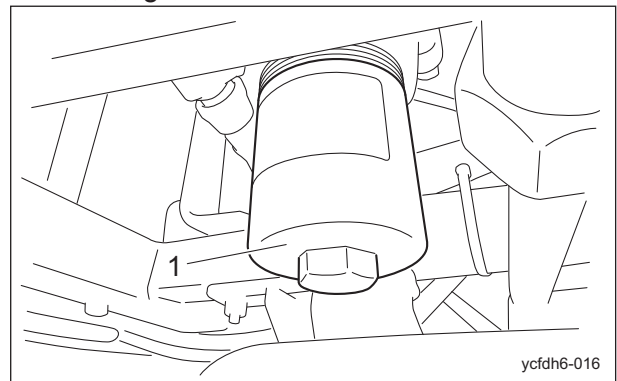

Change of Hydraulic Oil Line Filter_001

1	Cartridge filter
---	------------------

5. Supply hydraulic oil until it reaches the specified level. "Hydraulic Oil Supply" (Page 4-5)
6. Start the engine, and then after the hydraulic oil has warmed up, stop the engine.
7. Check underneath the machine for hydraulic oil leakage.

Change of Hydraulic Suction Filter

Caution

Be careful with hot oil, which could cause burns if it contacts your skin.

Important

When replacing the hydraulic oil filter, be sure to drain the oil into a container and discard it in accordance with local laws and regulations.

Important

If the hydraulic oil emulsifies or if it becomes even slightly less transparent, change the oil immediately.

Important

Use Shell Tellus S2M46 (or equivalent) as hydraulic oil.

Important

Replace the intake port packing with a new one.

1. On a level surface, lower the mower units, and then stop the engine.
2. Remove the center cover.
3. Remove bolts, spring washers and washers, and then remove the intake hose joint fitting.
4. Remove the old suction filter and intake port packing.
5. Remove all of the old liquid gasket from the hydraulic tank.
6. Remove all of the old liquid gasket and the intake port packing from the intake hose joint fitting.
7. Wash and clean the intake hose joint fitting.
8. Apply liquid gasket to the new intake port packing and then install it to the intake hose joint fitting.
9. Install the new suction filter to the intake hose joint fitting.

10. Install the intake hose joint fitting.

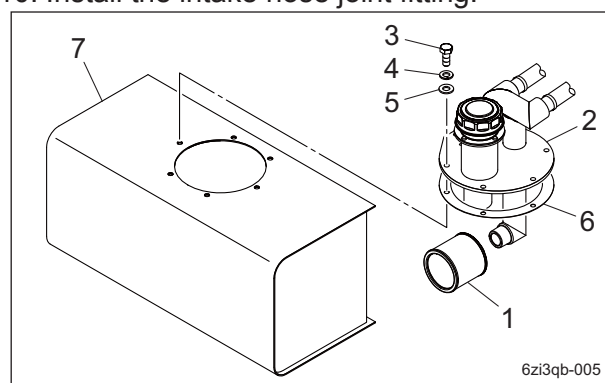

Change of Hydraulic Suction Filter_001

1	Suction filter
2	Intake hose joint fitting
3	Bolt
4	Spring washer
5	Washer
6	Intake port packing
7	Hydraulic tank

11. Install the center cover.
12. Supply hydraulic oil until it reaches the specified level.
"Hydraulic Oil Supply" (Page 4-5)
13. Start the engine and stop it after hydraulic oil warmed.
14. Check underneath the machine for hydraulic oil leakage.

Maintenance

Change of Hydraulic Oil

⚠ Caution

When you change the hydraulic oil, be sure to drain it into a bowl and discard it in accordance with local laws and regulations.

⚠ Caution

If the oil emulsifies or if it becomes even slightly less transparent, change the oil immediately.

⚠ Caution

Be careful with hot oil, which could cause burns if it contacts your skin.

Important

Use Shell Tellus S2M46 (or equivalent) as hydraulic oil.
In case of an equivalent, consult Characteristics of Hydraulic Oil and use hydraulic oil whose characteristics are superior to those of the specific hydraulic oil. Especially regarding kinematic viscosity and viscosity index, use of hydraulic oil whose figures are less than those of the specified hydraulic oil will cause a malfunction in the hydraulic circuit.

Note:

Characteristics of Hydraulic Oil

Specified Hydraulic Oil		Shell Tellus S2M46
ISO Viscosity Grade		ISO VG46
Density	15 °C (59 °F)	0.873 g/cm ³ (0.0315 lb/in ³)
API Gravity		30.6
Flash Point (Open Cup)		230 °C (446 °F)
Pour Point		-30 °C (-22 °F)
Kinematic	40 °C (104 °F)	46 mm ² /s (46 cSt)
Viscosity	100 °C (212 °F)	7 mm ² /s (7 cSt)
Viscosity Index		109

1. Follow the steps below to remove the old oil.

[1] Start and run the engine to warm up the oil.

[2] On a level surface, lower the mower units, and then stop the engine.

[3] Remove the drain plug of the hydraulic tank, and then drain the old oil into a container.

[4] Wind new sealing tape on the drain plug, and then attach it to the hydraulic tank.

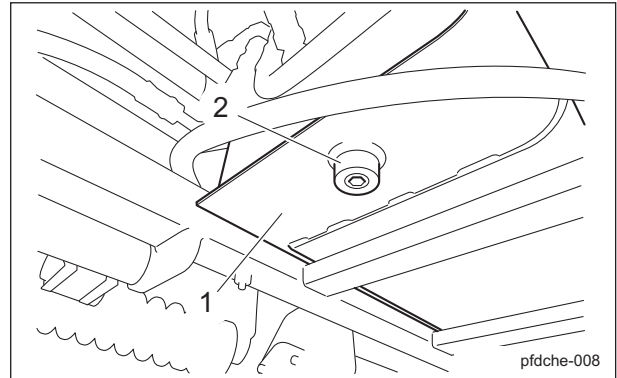

Change of Hydraulic Oil_001

1	Hydraulic tank
2	Drain plug

2. Follow the steps below to pour new oil.

The hydraulic tank capacity is approximately 35.0 dm³ (35.0 L).

[1] Release the catch clip and open the center cover.

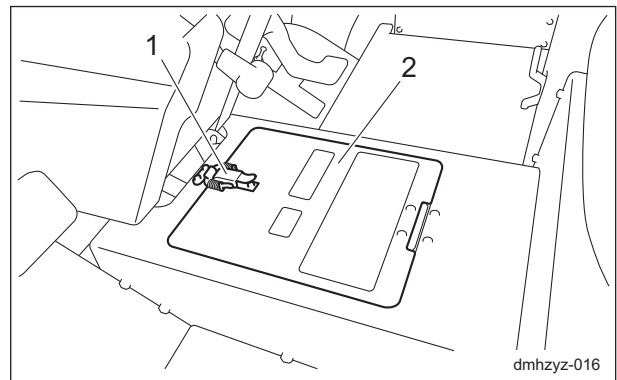

Change of Hydraulic Oil_002

1	Catch clip
2	Center cover

- [2] Open the tank cap and pour hydraulic oil from the fill port until the oil level reaches the middle of the oil gauge on the hydraulic tank.

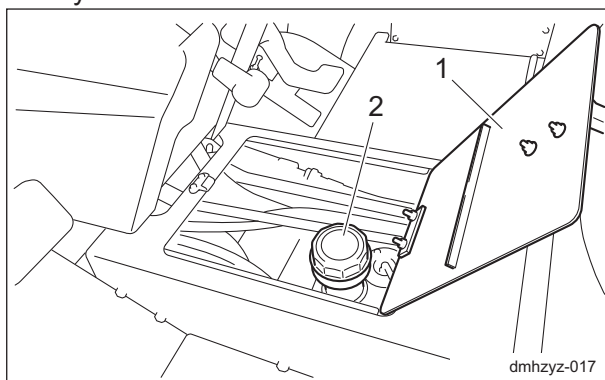

Change of Hydraulic Oil_003

1	Center cover
2	Tank cap

- [3] Tighten the tank cap securely.
 [4] Close the center cover and fasten with the catch clip.
- Start the engine, raise and lower the mower units, and turn the steering wheel left and right. Move forward and reverse repeatedly several times.
 - Lower the mower units and maintain that position on a level surface, and then check to see if the oil level is at the middle of the oil gauge. If necessary, supply oil.
 - Check underneath the machine for oil leakage.

Change of Air Cleaner

A contaminated air cleaner element may cause malfunction of the engine.

To maximize the life of the engine, replace the air cleaner element at the appropriate times.

- The timing for replacing the air cleaner element is described below.
 - Replace the air cleaner element in accordance with the Maintenance Schedule.
 - If it is significantly contaminated, replace it, even if the hours of operation do not exceed the specified time.
- Replace the air cleaner element by following the same steps as for cleaning the air cleaner. "Cleaning of Air Cleaner" (Page 4-6)

Change of Engine Oil

Warning

When you change the engine oil, be sure to drain it into a bowl and discard it in accordance with local laws and regulations.

Caution

Be careful with hot oil, which could cause burns if it contacts your skin.

Important

Be sure to use engine oil that is classified as API Service Grade CF or higher, with an SAE Viscosity that is appropriate for the operating environment (ambient temperature).

Important

Securely tighten the oil level gauge and oil filler cap.

Change the engine oil more frequently if the engine oil is contaminated, and especially if you use the machine in dusty areas or operate the engine at high loads or in high temperatures.

- Follow the steps below to remove the old engine oil.

[1] Start and run the engine to warm up the engine oil.

[2] Stop the engine on a level place.

[3] Remove the drain plug and then drain the old engine oil into a container.

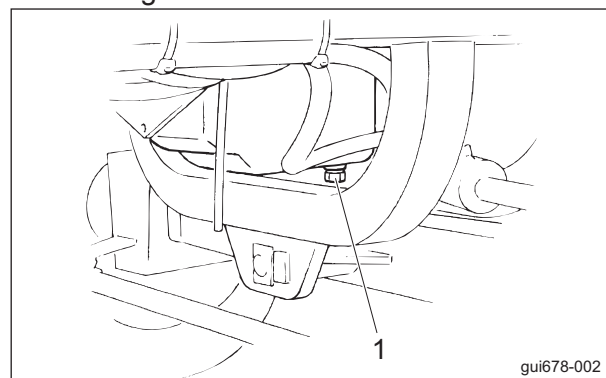

Change of Engine Oil_001

1	Drain plug
---	------------

- Re-place the drain plug.

Maintenance

- Remove the oil filler cap, and then supply new engine oil until the oil reaches a level in between the upper and lower limit lines on the oil level gauge.

Engine oil quantity is approximately 3.1 dm³ (3.1 L).

- Securely install the oil filler cap.

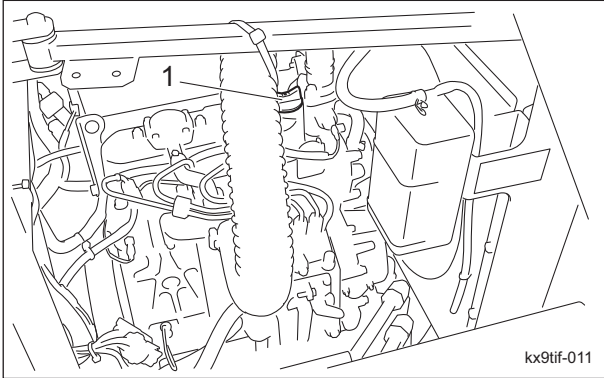

Change of Engine Oil_002

1	Oil filler cap
---	----------------

- It will take a while for the supplied engine oil to descend into the oil pan.
Check the oil level again 10 to 20 minutes after supplying the oil.
- Check underneath the machine for hydraulic oil leakage.

Change of Engine Oil Filter

⚠ Caution

Be careful with hot oil, which could cause burns if it contacts your skin.

Important

When replacing the engine oil filter, be sure to drain the engine oil into a container and discard it in accordance with local laws and regulations.

Important

Be sure to use engine oil that is classified as API Service Grade CF or higher, with an SAE Viscosity that is appropriate for the operating environment (ambient temperature).

Important

Securely tighten the oil level gauge and oil filler cap.

- With the filter wrench, remove the old filter cartridge.

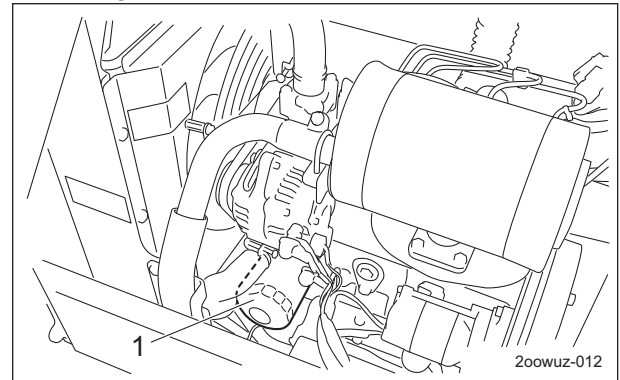

Change of Engine Oil Filter_001

1	Filter cartridge
---	------------------

- Lightly coat the packing of the new filter cartridge with engine oil.
- Hand-tighten the filter cartridge until the packing contacts the sealing surface, and then firmly hand-tighten (without using a filter wrench).
- Supply engine oil until it reaches the specified level.
"Supply of Engine Oil" (Page 4-9)
- Start the engine, and then stop it after 10 to 20 minutes.
- Make sure that there is no oil leakage at the sealing surface of the filter cartridge.
- Check the engine oil level.
If it is low, supply engine oil until it reaches the specified level.

Change of Fuel Filter Element

If dust or dirt accumulates in the fuel filter, the fuel flow will become insufficient. Replace the fuel filter at the appropriate times. The fuel filter is located on the left under the hood.

1. Close the fuel filter cock.

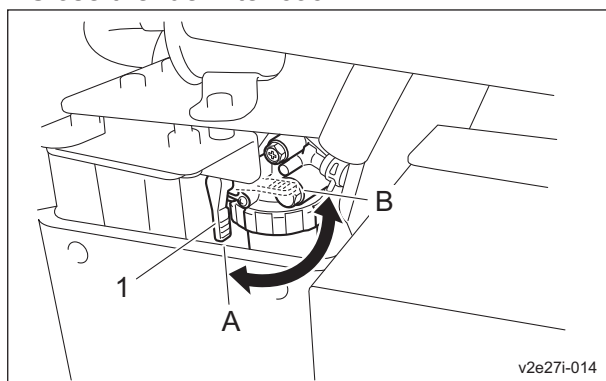

Change of Fuel Filter Element_001

1	Fuel cock
A	ON (Open)
B	OFF (Close)

2. Remove the retaining ring and then remove the cup.

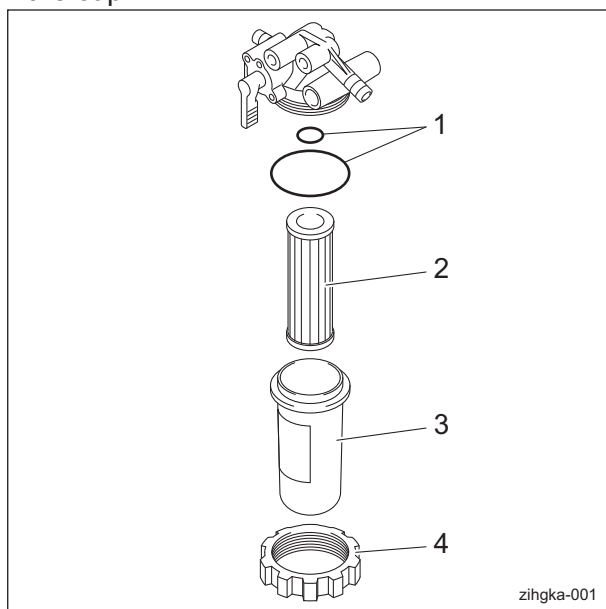

Change of Fuel Filter Element_002

1	O-ring
2	Element
3	Cup
4	Retaining ring

3. Clean the inside of the cup with light oil.

Important

When installed, be careful that it is not contaminated with dirt or dust. If the fuel is contaminated with dirt or dust etc., the fuel injection pump and injection nozzle will become worn.

4. Install a new element and put the parts back together.
5. Fill up the fuel tank with fuel and open the fuel cock.

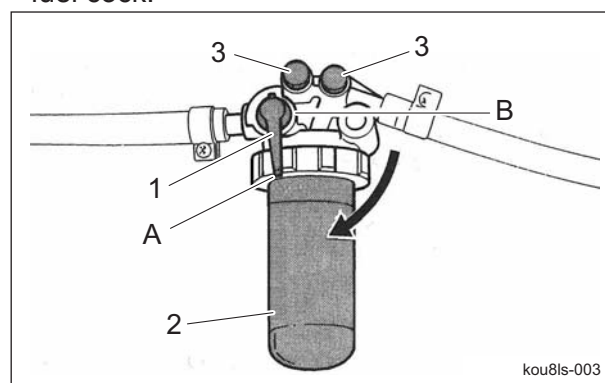

Change of Fuel Filter Element_003

1	Fuel cock
2	Fuel filter
3	Air-bleeding plug
A	ON (Open)
B	OFF (Close)

6. The key is turned to the "ON" position. The fuel pump is operated after replacement, air bleeding will occur automatically.
7. Turn the key to the "START" position and remove air out of the fuel line.
8. In the case that there are still air bubbles in the fuel from air-bleeding plug even after 15 seconds or more pass after setting the ignition key to "START", pause for 30 seconds or more and then repeat the same steps.

Maintenance

Change of Fuse

Important

When performing maintenance on the electrical system, be sure to remove the negative battery wire.

Important

If a fuse blows, a short may have occurred within the electrical circuit. Check for the cause, such as faulty terminal connections, damaged wiring or terminals, or incorrect wiring.

Important

For fuse replacement, clean the fuse mounting area with use of compressed air before mounting the fuse.

Fuse Box

The fuse box includes spare fuses and tools.

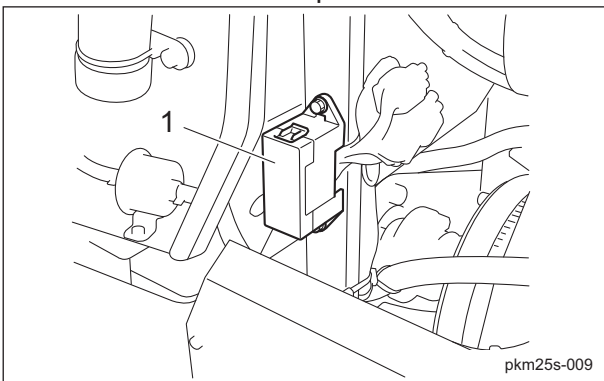

Fuse Box_001

1	Fuse box
---	----------

The fuses are standard mini fuses for automobiles. Replace them with fuses of the rated capacity.

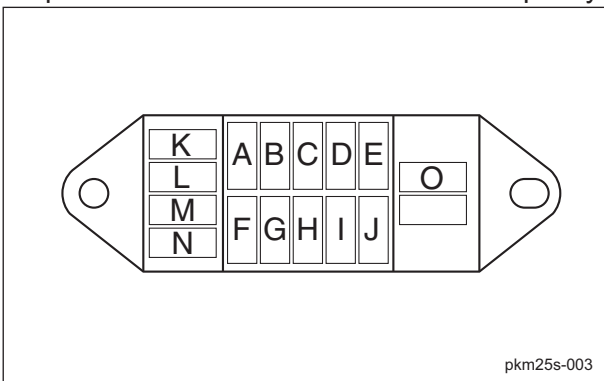

Fuse Box_002

A	5 A	Glow lamp timer
B	5 A	Glow lamp
C	5 A	Fuel pump
D	5 A	Charge lamp, oil pressure (engine oil pressure) lamp, water temperature gauge, buzzer, hour meter, fuel gauge
E	15 A	Reel normal rotation solenoid, reel reverse rotation solenoid, slight lift check valve
F	15 A	Light
G	5 A	Relay (starter motor)
H	5 A	Alternator (IG)
I	5 A	#4/#5 proximity switch relay, #4/#5 proximity switch, stop solenoid (when back lapping), relay box
J	5 A	Starter relay, safety relay, stop solenoid, reel rotation ON relay, lower lever relay, forward/reverse relay, unit down proximity switch, pump neutral proximity switch, brake proximity switch
K	5 A	Spare
L	5 A	Spare
M	15 A	Spare
N	15 A	Spare
O		Tool

Fusible Link

Fuse capacities of the fusible links are 30 A and 50 A.

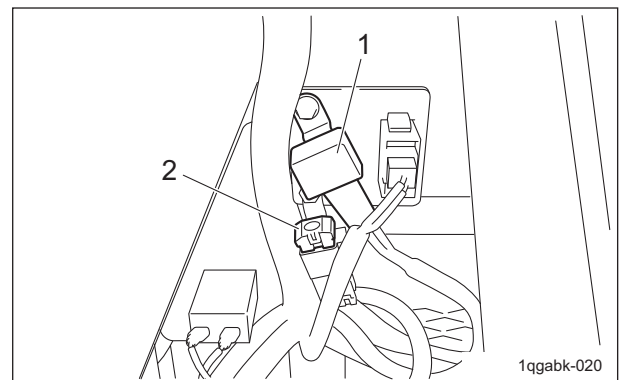

Fusible Link_001

1	Fusible link (30 A)
2	Fusible link (50 A)

EU Declaration of Conformity

Product Identification

Product : Lawnmower
Brand-Name : BARONESS
Type : LM531
Starting Serial No. : **10031**
Measured Sound Power Level : LWA 102.38 dB
Guaranteed Sound Power Level : LWA 105 dB
Manufacturer Name : Kyoisha Co., Ltd.
Address : 1-26 Miyuki-cho, Toyokawa, Aichi-pref., Japan

Conforms to the following Directives

2006/42/EC Machinery (MD)
2014/30/EU Electromagnetic compatibility (EMC)
2000/14/EC Noise emissions from outdoor equipment

We have been designed and manufactured under the following specifications

ISO 12100 : 2010 (2006/42/EC)
ISO 5395-1 : 2013 (2006/42/EC)
ISO 5395-3 : 2013 (2006/42/EC)
ISO 14982 : 1998 (2014/30/EU)

Keeper of Technical Documentation

Name : Kyoisha Co., Ltd.
Address : 1-26 Miyuki-cho, Toyokawa, Aichi-pref., Japan

Compiler of the technical file (2006/42/EC)

Name : Friedrich E. Barthels Nachf. Glockzin KG (GmbH & Co.)
Address : Gerhard-Falk-Str. 1 21035 Hamburg Germany

Conformity assessment procedures

Internal production control : Module A (2006/42/EC).
EC-type examination : Module B (2014/30/EU)
Internal control of production with assessment of technical documentation and periodical checking (2000/14/EC)

Involved Notified Body (2000/14/EC)

Name : TÜV SÜD Industrie Service GmbH
Address : Westendstraße 199 80686 München
Certificate : Notified Body NB0036 according 2000/14/EC

Place : Japan

Date : 20 January 2022 (20 / 1 / 2022)

Signature :



Name : Akio Hayashi

Position : Quality Dept. Director

Traduction de la Déclaration de Conformité originale (fr)

Déclaration de conformité UE

Identification du produit

Produit : Tondeuse à gazon
Fabriquant : BARONESS
Type : LM531
Numéro de série de début : **10031**
Niveau de puissance acoustique mesuré : LwA 102.38 dB
Niveau de puissance acoustique garanti : LwA 105 dB
Fabricant Nom : Kyoisha Co., Ltd.
Adresse : 1-26, Miyuki-cho, Toyokawa, préfecture d'Aichi, Japon

Conforme aux directives suivantes :

2006/42/CE Machine (MD)
2014/30/UE Compatibilité électromagnétique (CEM)
2000/14/CE Émissions sonores de l'équipement de plein air

Conception et fabrication en respect des spécifications suivantes :

ISO 12100 : 2010 (2006/42/CE)
ISO 5395-1 : 2013 (2006/42/CE)
ISO 5395-3 : 2013 (2006/42/CE)
ISO 14982 : 1998 (2014/30/UE)

Fiche technique

Marque : Kyoisha Co., Ltd.
Adresse de la marque : 1-26, Miyuki-cho, Toyokawa, préfecture d'Aichi, Japon

Compilateur de la fiche technique (2006/42/CE)

Nom : Friedrich E. Barthels Nachf. Glockzin KG (GmbH & Co.)
Adresse : Gerhard-Falk-Str. 1 21035 Hamburg Allemagne

Procédures d'évaluation de la conformité

Contrôle de production interne : module A (2006/42/CE)
Examen de type CE : module B (2014/30/UE)
Contrôle interne de la production avec évaluation de la fiche technique et vérification périodique (2000/14/CE)

Organisme notifié impliqué (2000/14/CE)

Nom : TÜV SÜD Industrie Service GmbH
Adresse : Westendstraße 199 80686 München
N° de certificat : Notified Body NB0036 according 2000/14/EC

Declaración de conformidad de la UE

Identificación del producto

Producto: Cortacésped
 Marca: BARONESS
 Tipo: LM531
 N.º de serie inicial: **10031**
 Nivel de potencia sonora medido: LWA 102.38 dB
 Nivel de potencia sonora garantizado: LWA 105 dB
 Fabricante Nombre: Kyoeshia Co., Ltd.
 Dirección: 1-26 Miyuki-cho, Toyokawa, Aichi-pref., Japón

Cumple las siguientes Directivas

2006/42/CE Maquinaria (MD)
 2014/30/UE Compatibilidad electromagnética (EMC)
 2000/14/CE Emisiones sonoras de máquinas de uso al aire libre

Se ha diseñado y fabricado utilizando las siguientes especificaciones

ISO 12100 : 2010 (2006/42/CE)
 ISO 5395-1 : 2013 (2006/42/CE)
 ISO 5395-3 : 2013 (2006/42/CE)
 ISO 14982 : 1998 (2014/30/UE)

Documentación técnica

Nombre del responsable: Kyoeshia Co., Ltd.
 Dirección del responsable: 1-26 Miyuki-cho, Toyokawa, Aichi-pref., Japón

Compilador del archivo técnico (2006/42/CE)

Nombre: Friedrich E. Barthels Nachf. Glockzin KG (GmbH & Co.)
 Dirección: Gerhard-Falk-Str. 1 21035 Hamburgo Alemania

Procedimientos de evaluación de conformidad

Control de fabricación interno: Módulo A (2006/42/CE)
 Examen de tipo CE: Módulo B (2014/30/UE)
 Control interno de fabricación con evaluación de documentación técnica y comprobaciones periódicas (2000/14/CE)

Organismo notificado implicado (2000/14/CE)

Nombre: TÜV SÜD Industrie Service GmbH
 Dirección: Westendstraße 199 80686 München
 Certificado: Notified Body NB0036 according 2000/14/EC

EU-Konformitätserklärung

Produktbeschreibung

Produkt: Rasenmäher
 Marke: BARONESS
 Modell: LM531
 Startseriennummer: **10031**
 Gemessener Schalleistungspegel: LWA 102.38 dB
 Garantierter Schalleistungspegel: LWA 105 dB
 Hersteller Name: Kyoeshia Co., Ltd.
 Adresse: 1-26 Miyuki-cho, Toyokawa, Aichi-pref., Japan

Entspricht den folgenden Richtlinien

2006/42/EG Maschinenrichtlinie
 2014/30/EU Elektromagnetische Verträglichkeit (EMV)
 2000/14/EG Geräuschemission von im Freien betriebenen Geräten

Unter Anwendung der folgenden Bestimmungen entwickelt und hergestellt

ISO 12100 : 2010 (2006/42/EG)
 ISO 5395-1 : 2013 (2006/42/EG)
 ISO 5395-3 : 2013 (2006/42/EG)
 ISO 14982 : 1998 2014/30/EU)

Technische Dokumentation

Name des Halters: Kyoeshia Co., Ltd.
 Adresse des Halters: 1-26 Miyuki-cho, Toyokawa, Aichi-pref., Japan

Technische Unterlagen erstellt von (2006/42/EG)

Name: Friedrich E. Barthels Nachf. Glockzin KG (GmbH & Co.)
 Adresse: Gerhard-Falk-Str. 1 21035 Hamburg Deutschland

Konformitätsbewertungsverfahren

Interne Produktionskontrolle : Modul A (2006/42/EG)
 EG-Baumusterprüfung : Modul B (2014/30/EU)
 Interne Produktionskontrolle mit Bewertung der technischen Unterlagen und regelmäßiger Überprüfung (2000/14/EG)

Beteiligte benannte Stelle (2000/14/EG)

Name: TÜV SÜD Industrie Service GmbH
 Adresse : Westendstraße 199 80686 München
 Bescheinigung : Notified Body NB0036 according 2000/14/EC

EU-försäkran om överensstämmelse

Produktidentifikation

Produkt : Gräsklippare
 Märke: BARONESS
 Typ: LM531
 Serienummer startar på: **10031**
 Uppmätt ljudeffektnivå: LWA 102.38 dB
 Garanterad ljudeffektnivå: LWA 105 dB
 Tillverkare Namn: Kyoisha Co., Ltd.
 Adress: 1-26 Miyuki-cho, Toyokawa, Aichi-pref., Japan

Uppfyller följande direktiv

2006/42/EG Maskindirektivet
 2014/30/EU Elektromagnetisk kompatibilitet (EMC)
 2000/14/EG Bulleremission från utomhusutrustning

Följande kravspecifikationer har följts vid konstruktion och tillverkning

ISO 12100 : 2010 (2006/42/EG)
 ISO 5395-1 : 2013 (2006/42/EG)
 ISO 5395-3 : 2013 (2006/42/EG)
 ISO 14982 : 1998 (2014/30/EU)

Teknisk dokumentation

Innehavarens namn: Kyoisha Co., Ltd.
 Innehavarens adress: 1-26 Miyuki-cho, Toyokawa, Aichi-pref., Japan

Den tekniska filen(2006/42/EG) har tagits fram av

Namn: Friedrich E. Barthels Nachf. Glockzin KG (GmbH & Co.)
 Adress: Gerhard-Falk-Str. 1 21035 Hamburg Tyskland

Förfarande för bedömning av överensstämmelse

Intern produktionskontroll: Modul A (2006/42/EG)
 EG-typprovning: Modul B (2014/30/EU)
 Intern kontroll av produktion med fastställande av teknisk dokumentation och periodiska kontroller (2000/14/EG)

Anmält organ (2000/14/EG)

Namn: TÜV SÜD Industrie Service GmbH
 Adress: Westendstraße 199 80686 München
 Certifikat : Notified Body NB0036 according 2000/14/EC

EU-overensstemmelseserklæring

Produktidentificering

Produkt : Plæneklipper
 Mærkenavn: BARONESS
 Type: LM531
 Startende serienr.: **10031**
 Målt lydtekniveau: LWA 102.38 dB
 Garanteret lydtekniveau: LWA 105 dB
 Producent Navn: Kyoisha Co., Ltd.
 Adresse: 1-26 Miyuki-cho, Toyokawa, Aichi-præf., Japan

Er i overensstemmelse med følgende direktiver

2006/42/EF Maskineri (MD)
 2014/30/EU Elektromagnetisk kompatibilitet (EMC)
 2000/14/EF Støjmissioner fra udendørs udstyr

Vi har designet og produceret under følgende specifikationer

ISO 12100 : 2010 (2006/42/EF)
 ISO 5395-1 : 2013 (2006/42/EF)
 ISO 5395-3 : 2013 (2006/42/EF)
 ISO 14982 : 1998 (2014/30/EU)

Indehaver af teknisk dokumentation

Navn: Kyoisha Co., Ltd.
 Adresse: 1-26 Miyuki-cho, Toyokawa, Aichi-præf., Japan

Kompilator af den tekniske fil (2006/42/EF)

Navn: Friedrich E. Barthels Nachf. Glockzin KG (GmbH & Co.)
 Adresse: Gerhard-Falk-Str. 1 21035 Hamburg Tyskland

Procedurer for overensstemmelsesvurdering

Intern produktionskontrol : Modul A (2006/42/EF)
 EF-typeafprøvning : Modul B (2014/30/EU)
 Intern fabrikationskontrol med vurdering af teknisk dokumentation og periodisk kontrol (2000/14/EF)

Berørt bemyndiget organ (2000/14/EF)

Navn: TÜV SÜD Industrie Service GmbH
 Adresse: Westendstraße 199 80686 München
 Certifikat: Bemyndiget organ NB0036 ifølge 2000/14/EF

BARONESS[®]
Quality on Demand

 **KYOEISHA CO., LTD.**
Head Office 1-26, Miyuki-cho, Toyokawa-city, Tel :+81-533-84-1390
Aichi-pref, 442-8530 JAPAN Fax:+81-533-84-1220