

# TR50

EZ Carry

## Parts catalog

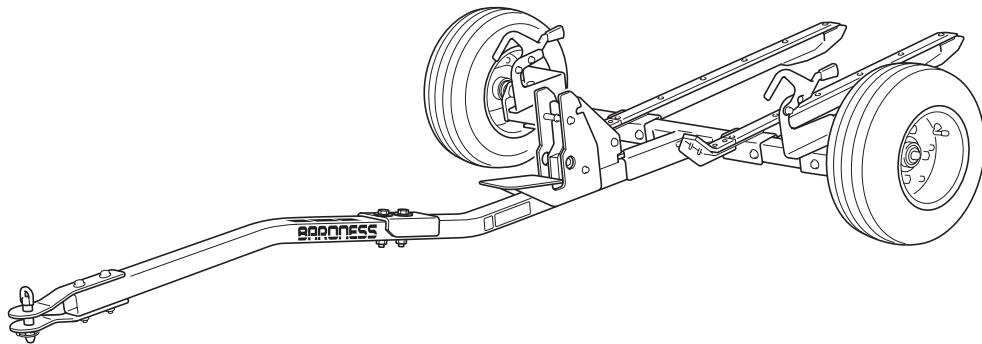

**BARONNESS**<sup>®</sup>  
Quality on Demand

## Greetings

---

Thank you for purchasing Baroness product.

This brochure contains the information needed for ordering BARONESS parts.

Search the number indicating the figure of your desired part in the illustration area, and find the same number from among the latter parts of the hyphenated Cat Nos. in the listing area to obtain the individual Code No.

## Notes

---

### 1) For inquiries of parts

Inform us of the model and the serial number of your machine or attachment.

The model and the serial number are indicated on the serial number plate of your machine or attachment.

\* Consult the Owner's Operating Manual for the position where the serial number plate is affixed.

### 2) For ordering parts

- Inform us of the Code No., Part name and order quantity.
- We do not accept returns unless our company is responsible for the issue.
- Use genuine Baroness parts and accessories. The Baroness product warranty may not apply if parts or accessories from other companies are used.

### 3) The information described in this brochure is subject to change without prior notice.

# Description of the content of Parts catalog

## 1) Illustration area

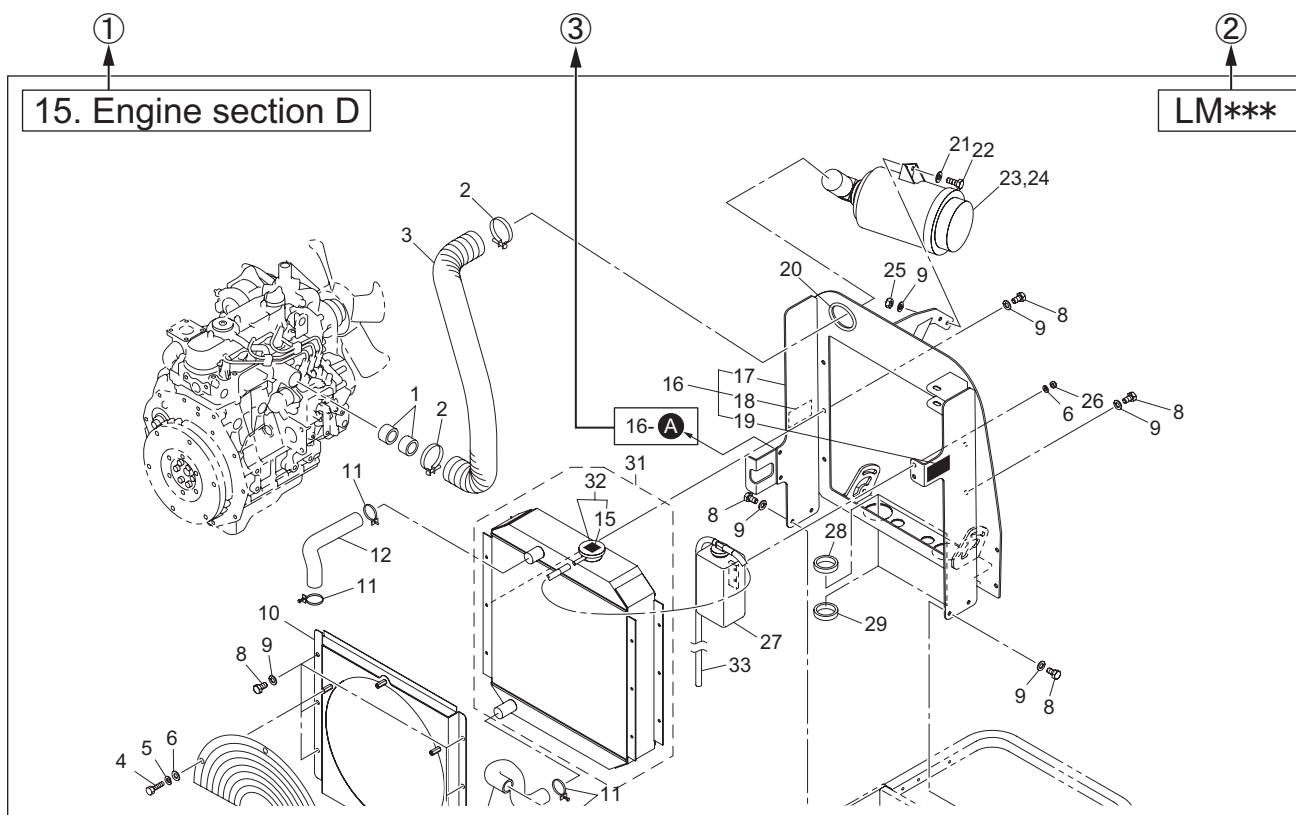

- ① Section No. /Section name
- ② Model
- ③ Indication of the connecting point

The following indication shows the connecting point of the part shown on the other page.

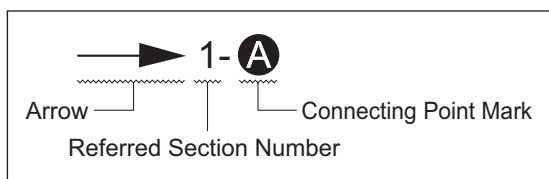

- 1- **A** :  
Refer to the point **A** in the illustration of the section No.1
- 2- **B** :  
Refer to the point **B** in the illustration of the section No.2

Note :

The figures of assembled components or isolated parts do not always show their accurate shapes. The figures are supposed to be used for obtaining the correct code numbers.

## 2) Listing area

① Cat No.	② Code No.	③ Part name	④ ⑤ Qty			⑥ Remark	⑦ SN of application
1 - 1	K0000080152	BOLT, M8-15	2	2	2		
1 - 2	K0185160002	NUT, LEFT-HANDED P1.5 M16-3	2	2	2		
1 - 3	K3650000100	HOUR METER, HH2AS	1	1	1		10001-10023
1a- 3	K3650000130	HOUR METER, 636DC	1	1	1		10024-
1 - 4	K0100060002	NUT, M6	2	2	2		
1 - 5	K0003080702	BOLT, M8-70	1	1	1		
1 - 7	K0830000020	OIL SEAL, 254210	2	2	2		

### ① Cat No. or Catalog No.

Find the same number as the number indicating the figure of your desired part in the illustration area from among the latter parts of the hyphenated Cat Nos. to obtain the individual Code No.

### ② Code No.

Identification code of an individual part

### ③ Part name

### ④ Qty

Quantity needed per Cat No.

### ⑤ Model

When the quantity differs by models, the models are indicated.

### ⑥ Remark

Specification or description, etc. of the part may be indicated.

### ⑦ SN of application

In case of part alteration, the serial number ranges of machines to which the alteration is applied will be indicated.

## 3) Indication in case of part alteration

- When a new part and an old one are interchangeable with each other, indication of the old part code No. is discontinued and the new part code No. is solely indicated.
- When a new part and an old one are not interchangeable, the serial number ranges of both machines where the new part is used and those where the old one is used are indicated in the SN of application column.
- When a part is newly added, the serial number range of machines where the part is used is indicated in the SN of application column.
- When a part was previously used but the part is not used in the machine any longer, the serial number range of machines where the part was used is indicated in the SN of application column.

# Contents

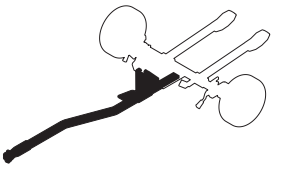
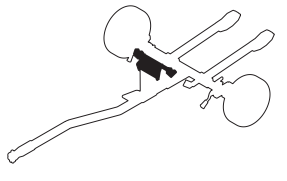
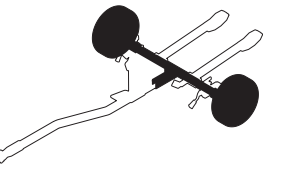
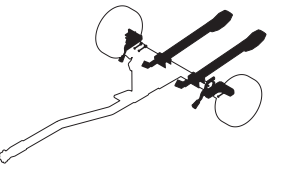
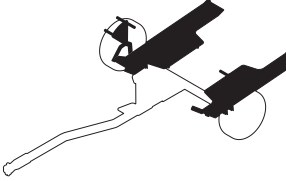
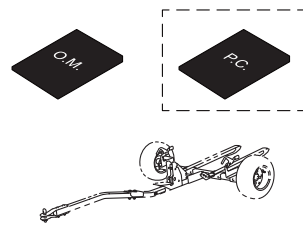
<p>1.Towing section A.....1</p>  A line drawing of a towing section A, showing a long, angled tow bar connected to a hitch mechanism with a ball and a receiver.	<p>2.Towing section B.....3</p>  A line drawing of a towing section B, showing a hitch mechanism with a ball and a receiver, similar to section A but with a different tow bar design.	<p>3.Wheel &amp; Axle section.....4</p>  A line drawing of a wheel and axle assembly, showing a solid black wheel mounted on a central axle with a hub.	<p>4.Tilting table section A for Mower without wheels .....5</p>  A line drawing of a tilting table section A, showing a platform with a hitch and a tilting mechanism.
<p>5.Tilting table section B for Mower with wheels .....6</p>  A line drawing of a tilting table section B, showing a platform with a hitch and a tilting mechanism, designed for a mower with wheels.	<p>6.Accessories .....7</p>  A diagram showing two accessories: a black rectangular plate labeled 'O.M.' and another labeled 'P.C.' which is enclosed in a dashed rectangular box. Below these plates is a line drawing of a wheel and axle assembly.		

# 1.Towing section A

TR50

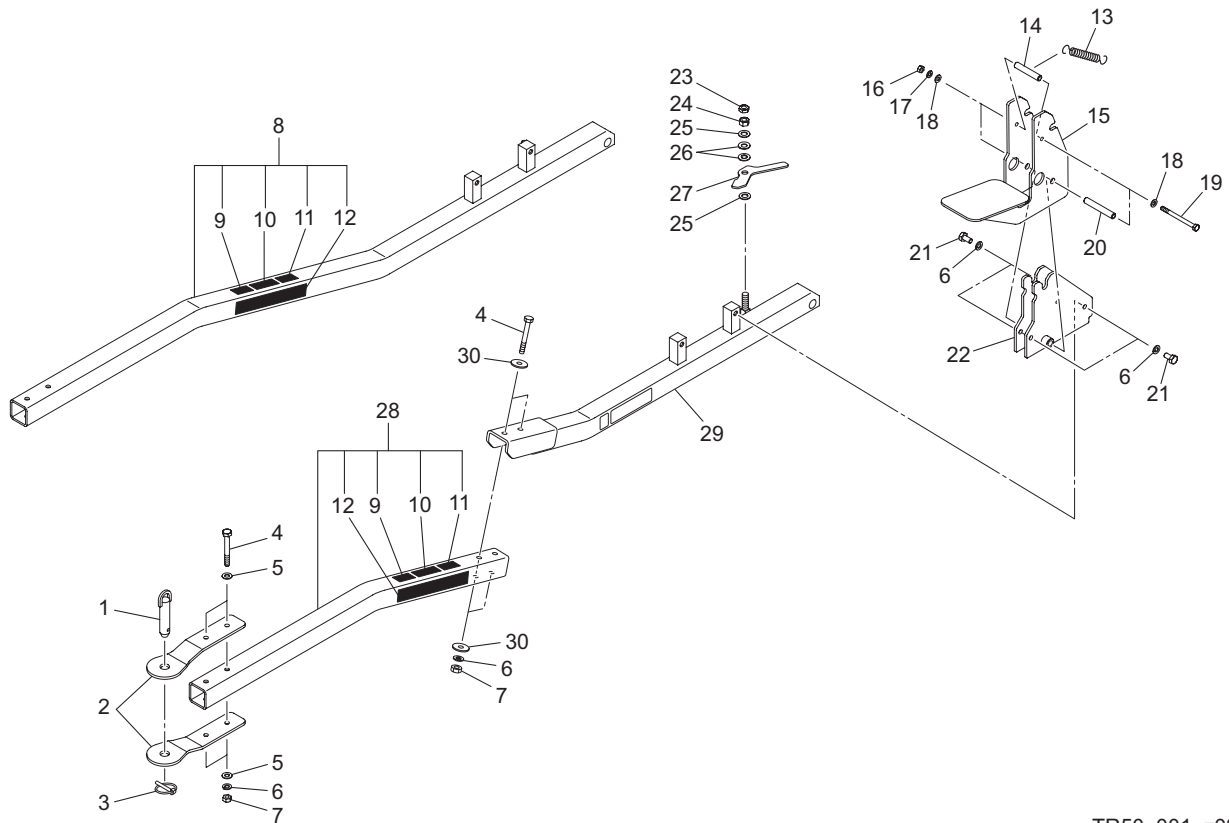

TR50\_001\_z03

Cat No.	Code No.	Part name	Qty	Remark	SN of application
1-1	K7147000288	HOOK, W/ PIN 20-83	1		
1-2	TR50---0105ZR	HITCH, FIXING TRAILER	2		
1-3	K6061060002	PIN, CLIP M6	1		
1-4	K0000100802	BOLT, M10-80	2		10066-10375
1a-4	K0000100802	BOLT, M10-80	4		10376-
1-5	K5000100002	WASHER, M10	4		
1-6	K0200100002	WASHER, SPRING M10	6		10066-10375
1a-6	K0200100002	WASHER, SPRING M10	8		10376-
1-7	K0100100002	NUT, M10	2		
1-8	TR50---0150Z0	BAR, TOWING W/DECAL	1		10066-10375
1-9	K4205002160	DECAL, READ OWNERS MANUAL	1		
1-10	K4205002170	DECAL, CAUTION AT SLOPE	1		
1-11	K4205002180	DECAL, PROHIBITED TO RIDE ON	1		
1-12	K4201000180	STICKER, BARONESS 36	2		
1-13	K1020000088	SPRING, W/ROUND HOOK M2.3-17-78	1		
1-14	K6212004362	COLLAR, STKM 8.8-12-71	1		
1-15	TR50---0103AD	HOOK, LOCKING	1		
1-16	K0100080002	NUT, M8	2		
1-17	K0200080002	WASHER, SPRING M8	2		
1-18	K5000080002	WASHER, M8	4		
1-19	K0003081002	BOLT, M8-100	2		
1-20	K6212004342	COLLAR, STKM M8.2-12.7-84	1		
1-21	K0000100202	BOLT, M10-20	4		
1-22	TR50---0107ZR	RETAINER, HOOK	1		
1-23	K0102120002	NUT, M12-3	1		
1-24	K0100120002	NUT, M12	1		
1-25	K5000120002	WASHER, M12	2		
1-26	K0211120002	SPRING, CONICAL DISC H M12	2		
1-27	TR50---0112ZD	HOOK, SECURING AXLE	1		
1-28	TR50---0152Z0	BAR, TOWING W/DECAL	1		10376-

# 1.Towing section A

TR50

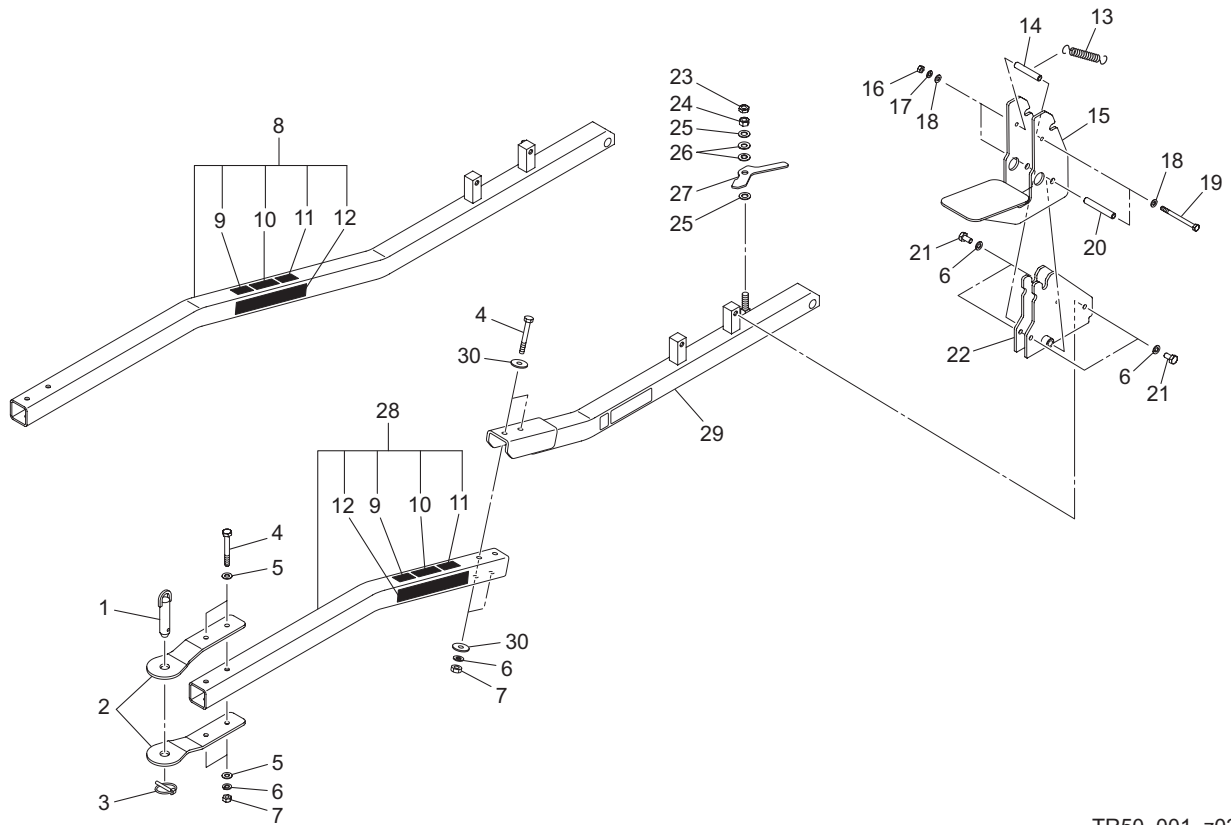

TR50\_001\_z03

Cat No.	Code No.	Part name	Qty	Remark	SN of application
1-29	TR50---0113ZR	BAR, TOWING (REAR)	1		10376-
1-30	K5073210352	WASHER, SPHC 3.2-10-35	4		10376-

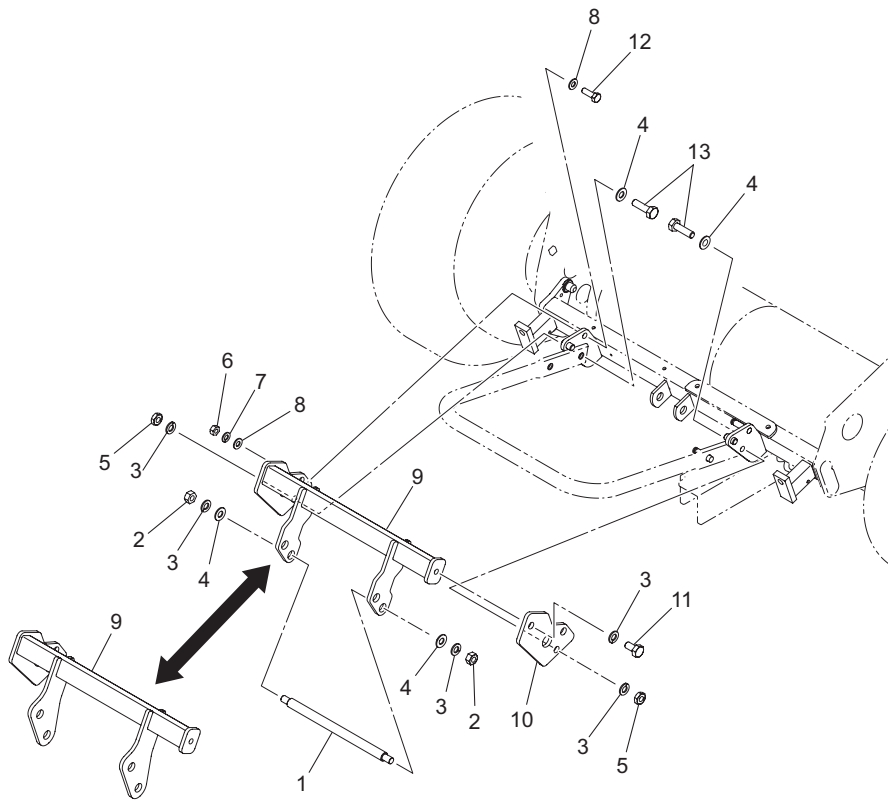

TR50\_002\_z01

Cat No.	Code No.	Part name	Qty	Remark	SN of application
2-1	TR50---0110Z2	BAR, ROUND W/M10 14-230	1		
2-2	K0100100002	NUT, M10	2		
2-3	K0200100002	WASHER, SPRING M10	5		
2-4	K5000100002	WASHER, M10	4		
2-5	K0102100002	NUT, M10-3	2		
2-6	K0100080002	NUT, M8	1		
2-7	K0200080002	WASHER, SPRING M8	1		
2-8	K5000080002	WASHER, M8	2		
2-9	TR50---0108ZD	FIXTURE, MOWER	1		10066-10115
2a-9	TR50---0108AD	FIXTURE, G MOWER	1		10116-
2-10	TR50---0109ZD	PLATE, SIDE	1		
2-11	K0000100202	BOLT, M10-20	1		
2-12	K0000080252	BOLT, M8-25	1		
2-13	K0000100352	BOLT, M10-35	2		



### 3.Wheel & Axle section

TR50

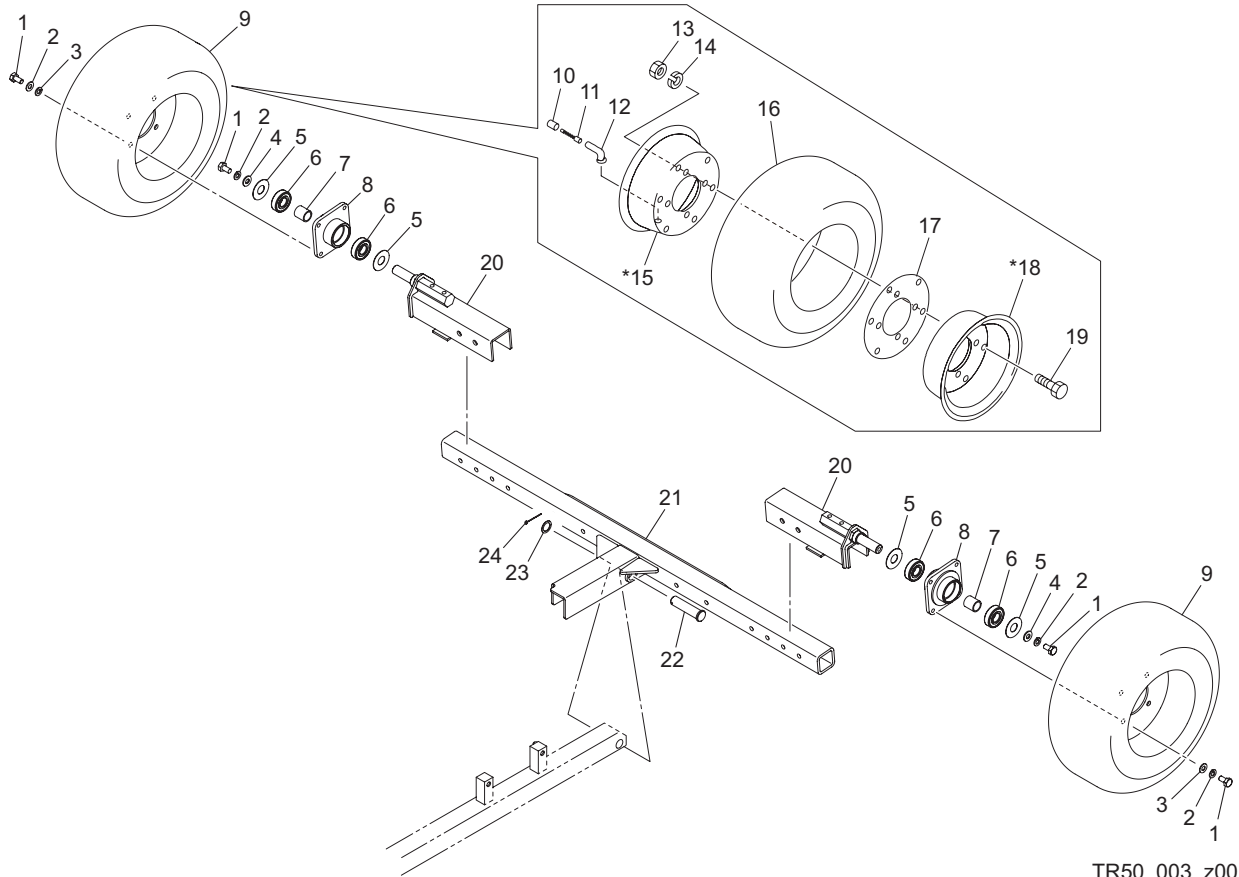

TR50\_003\_z00

Cat No.	Code No.	Part name	Qty	Remark	SN of application
3-1	K0000100202	BOLT, M10-20	10		
3-2	K0200100002	WASHER, SPRING M10	10		
3-3	K5000100002	WASHER, M10	8		
3-4	K5073210352	WASHER, SPHC 3.2-10-35	2		
3-5	K5011020472	WASHER, SPCC 1-20-47	4		
3-6	K0612062040	BEARING, BALL SEAL 2RD 6204	4		
3-7	K6212000210	COLLAR, STKM 20.2-25.4-27	2		
3-8	GM950-0409Z2	HOUSING, FOR FRONT WHEEL	2		
3-9	K2070000040	TIRE ASSY, 16*6.50-8	2		
3-10	K2093000010	CAP, VALVE	2		
3-11	K2092000010	CORE, VALVE NO.8000	2		
3-12	K2097000040	VALVE, RIM PVR70	2		
3-13	K0100080002	NUT, M8	12		
3-14	K0200080002	WASHER, SPRING M8	12		
3-15	K209000012L	WHEEL, 5.50-8 W/VALVE HOLE	2	Order w/3-18	
3-16	K2071000030	TIRE, 16*6.50-8 R810APR4	2		
3-17	K2095000010	PACKING, F-8P-D	2		
3-18	K209000011L	WHEEL, 5.50-8	2	Order w/3-15	
3-19	K0000080152	BOLT, M8-15	12		
3-20	TR50---0301AR	BRACKET, WHEEL SHAFT	2		
3-21	TR50---0201ZR	AXLE	1		
3-22	K6031200822	PIN, FLAT HEAD HT M20-82	1		
3-23	K5011020282	WASHER, SPCC 1-20-28	1		
3-24	K0300032402	PIN, COTTER M3.2-40	1		

# 4. Tilting table section A for Mower without wheels

TR50

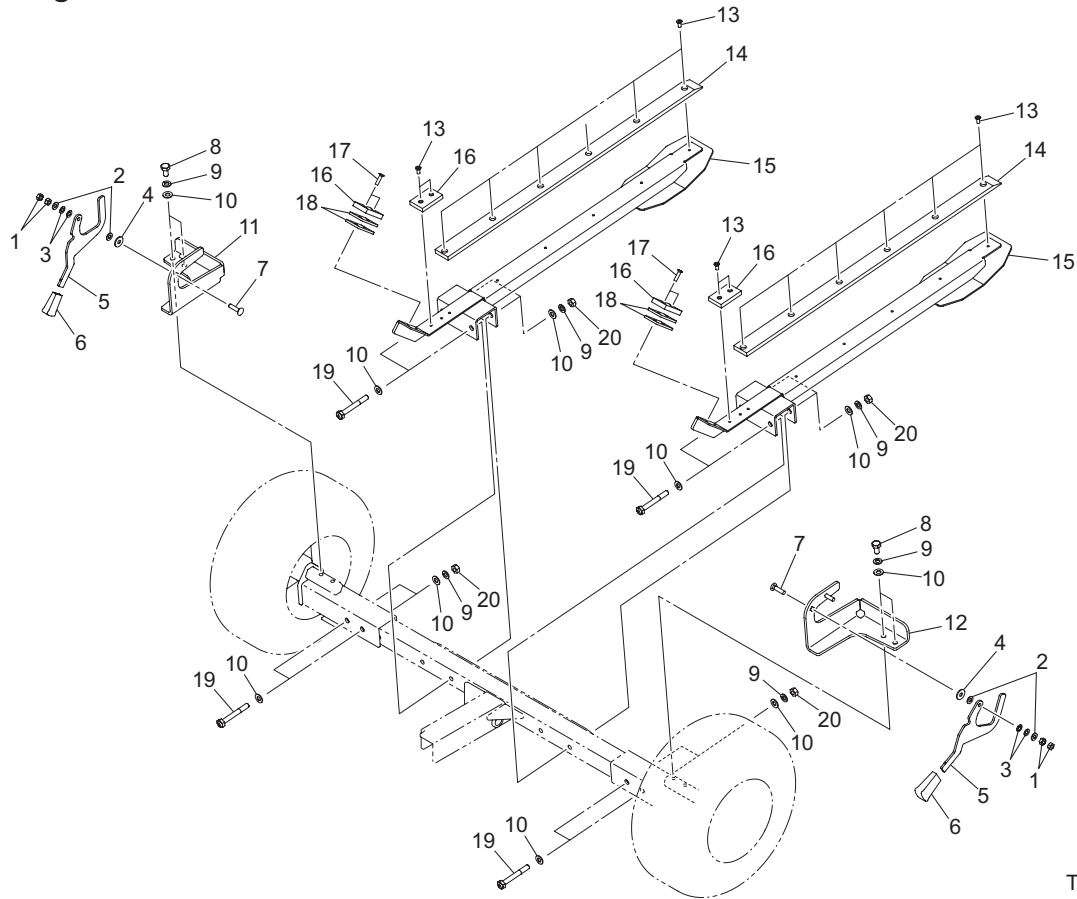

TR50\_004\_z00

Cat No.	Code No.	Part name	Qty	Remark	SN of application
4-1	K0100080002	NUT, M8	4		
4-2	K5000080002	WASHER, M8	4		
4-3	K0210080002	SPRING, CONICAL DISC L M8	4		
4-4	K5073208202	WASHER, SPHC 3.2-8-20	2		
4-5	TR50---0404Z2	LEVER, LOCKING DRUM SHAFT	2		
4-6	K1301000130	GRIP, PLASTIC SQUARE	2		
4-7	K0025080352	BOLT, CARRIAGE M8-35	2		
4-8	K0000100202	BOLT, M10-20	4		
4-9	K0200100002	WASHER, SPRING M10	12		
4-10	K5000100002	WASHER, M10	20		
4-11	TR50---0409ZD	LOCK, DRUM SHAFT (LH)	1		
4-12	TR50---0408ZD	LOCK, DRUM SHAFT (RH)	1		
4-13	K0041060152	SCREW, + FLAT HEAD M6-15	16		
4-14	TR50---0410Z0	RUBBER, CR 10-40-795C	2		
4-15	TR50---0401AR	TILTING TABLE, DRUM	2		
4-16	K4033000380	STOPPER, URETHAN RUBBER	4		
4-17	K0041060252	SCREW, + FLAT HEAD M6-25	4		
4-18	K511700036R	PLATE, SPHC 4.5-40-63 W/HOLE	0-4	for adjustment	
4-19	K0013100802	BOLT, HT M10-80	8		
4-20	K0100100002	NUT, M10	8		

# 5. Tilting table section B for Mower with wheels

TR50

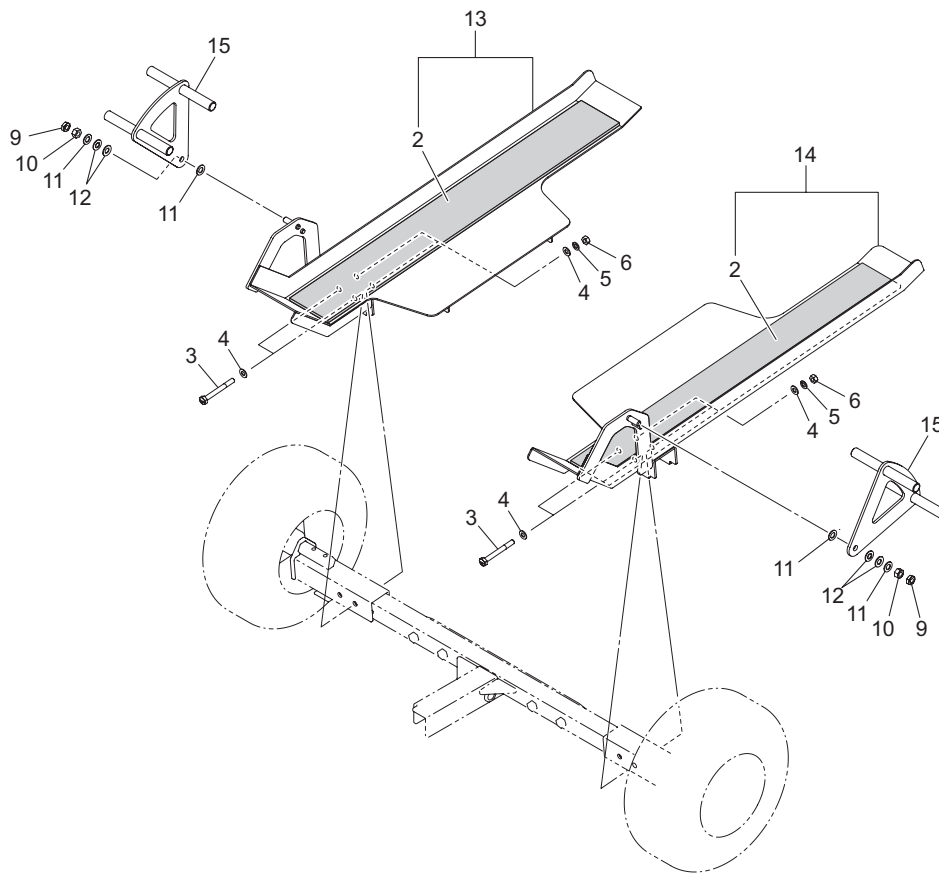

TR50\_005\_z01

Cat No.	Code No.	Part name	Qty	Remark	SN of application
5-1					
5-2	K4400000110	SHEET, NONSKID 910100	2		
5-3	K0013100902	BOLT, HT M10-90	4		
5-4	K5000100002	WASHER, M10	8		
5-5	K0200100002	WASHER, SPRING M10	4		
5-6	K0100100002	NUT, M10	4		
5-7					
5-8					
5-9	K0102120002	NUT, M12-3	2		
5-10	K0100120002	NUT, M12	2		
5-11	K5000120002	WASHER, M12	4		
5-12	K0211120002	SPRING, CONICAL DISC H M12	4		
5-13	TR50---0512Z0	TILTING TABLE, TIRE W/MARK (RH)	1		
5-14	TR50---0513Z0	TILTING TABLE, TIRE W/MARK (LH)	1		
5-15	TR50---0511ZD	LEVER, LOCKING TIRE	2		

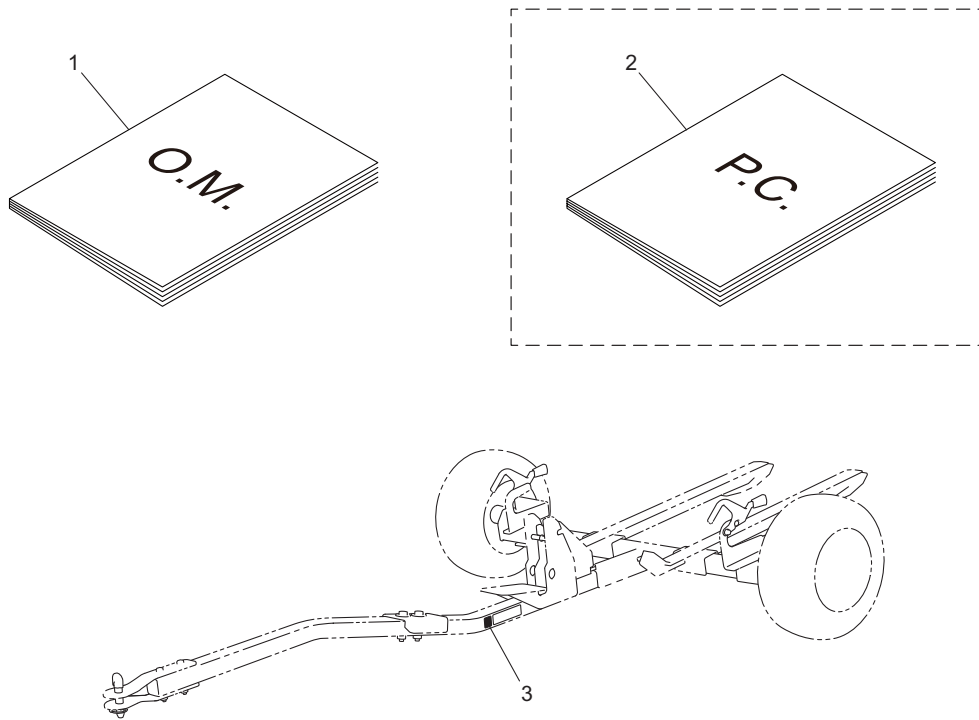

TR50\_006\_z01

Cat No.	Code No.	Part name	Qty	Remark	SN of application
6a-1	750103-122-A	OWNERS OPERATING MANUAL, TR50	1		
6a-1	750103-122-B	PARTS CATALOG, TR50	1	Available for sale	11101-
6-3	TR50---0701Z0	LABEL, QR CODE TR50	1		11101-

# MEMO

# MEMO

# MEMO

**BARONESS**<sup>®</sup>  
Quality on Demand

 **KYOEISHA CO., LTD.**  
Head Office 1-26, Miyuki-cho, Toyokawa-city, Tel :+81-533-84-1390  
Aichi-pref, 442-8530 JAPAN Fax :+81-533-84-1220