

LM180E

3-Unit Reel Mower

Owner's Operating Manual

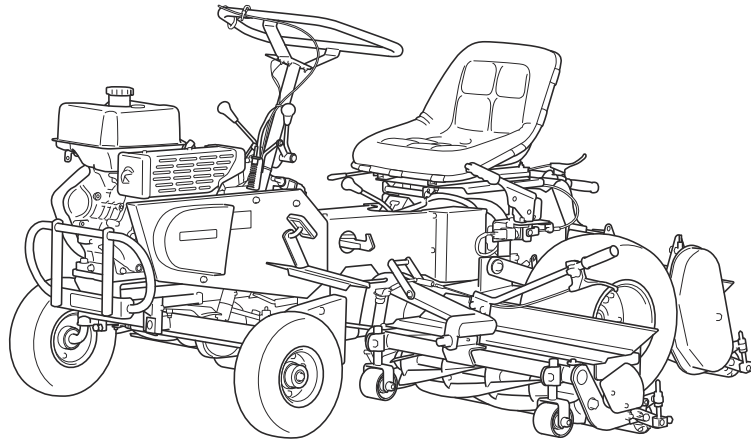

Serial No. LM180E : 21056-

"Required reading"
Read this manual before using the machine.

BARONESS[®]
Quality on Demand

Original Instructions Ver.1.6

LM180E

Regulations

EU Regulations

(For EU)

This product complies with all relevant EU Regulations.

For more information, please refer to the Declaration of Conformity attached.

Thank you for purchasing the Baroness product. This manual describes the proper handling, adjustment, and inspection of your product. We hope you will use the product safely, and take advantage of its best performance.

Keeping the Owner's Operating Manual

Keep this manual in the box on the right side of the seat.

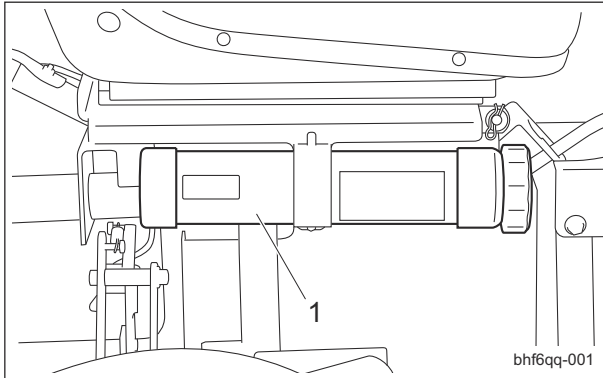

Keeping the Owner's Operating Manual_001

1	Box
---	-----

QR Code

A QR code label is affixed on the machine.

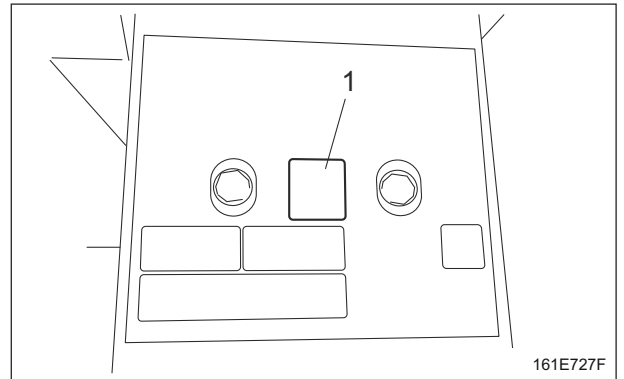

QR Code_001

1	QR code label
---	---------------

Scan the QR code with your smartphone for easy access to Baroness Manual Reference Service where you can browse Owner's Operating Manual and Parts Catalog.
<https://doc.baroness-international.com/manuals/LM180E>



QR Code_002

Introduction

Read this manual carefully to ensure that you thoroughly understand how to properly operate and maintain the product, and to avoid causing injury to yourself or others.

The operator is responsible for operating the product properly and safely.

Maintenance service for this machine should be performed by a mechanic with expertise.

If you have any questions concerning maintenance or genuine parts, please contact a Baroness dealer or Kyoisha.





When making inquiries about your product, please specify the model and serial number.

When loaning or transferring the product, please also provide this manual together with the product.

Kyoisha Co., Ltd.

Warning Symbols

This manual uses the following warning symbols for handling precautions that are important for your safety.

 <small>696cq5-001</small>	Warning symbol
<p>This symbol indicates the articles regarding “Danger,” “Warning,” or “Caution.” Those articles describe important safety precautions and so read them carefully to understand completely before operating the machine.</p> <p>Failure to adequately follow these safety precautions may cause an accident.</p>	
<p> Danger</p> <p>This symbol indicates that serious injury or death will occur if the warning is ignored.</p>	
<p> Warning</p> <p>This symbol indicates that serious injury or death may occur if the warning is ignored.</p>	
<p> Caution</p> <p>This symbol indicates that injury or damage to property may occur if the warning is ignored.</p>	
<p>Important</p> <p>This symbol indicates precautions on the mechanism of the machine.</p>	

Precautionary Statement

 Caution

The information described in this manual is subject to change for improvement without prior notice.

When replacing parts, be sure to use genuine Baroness parts or parts designated by Kyoeshia.

Note that the Baroness product warranty may not apply to defects caused by the use of parts from other companies.

Prior to use, carefully read the following manuals to thoroughly understand the contents for safe and correct operation.

- Baroness Owner's Operating Manual
- The Engine's Owner's Manual

Purpose

This product is intended for cutting turf grass at golf courses.

Do not use this product in any way other than its intended purpose, and do not modify this product.

Operating this product for other purposes and modifying it may be very dangerous and may cause damage to the product.

In addition, this product is not authorized for operation as a special motor vehicle. Do not operate it on public roads.

LM180E

Introduction

Safety	Page 1-1	Replace	Page 6-18
Safe Operating Practices	Page 1-2	Storage	Page 6-21
Disposal	Page 2-1	Repair	Page 7-1
Recycle and Waste Disposal	Page 2-2	Precautions for Repair	Page 7-2
Product Overview	Page 3-1	Adjustment	Page 7-2
Specifications	Page 3-2	Towing	Page 7-5
Names of Each Section	Page 3-4	Appended Table	Page 8-1
Regulation Decals	Page 3-4	Tightening Torques	Page 8-2
Safety Signs and Instruction Signs	Page 3-6	Daily Check List	Page 8-5
Operation Decals	Page 3-8	Maintenance Schedule	Page 8-6
Description of Functions	Page 4-1	List of Adjusted Values	Page 8-7
Engine Switch	Page 4-2		
Throttle Lever	Page 4-2		
Change Lever	Page 4-2		
Traveling Clutch Lever	Page 4-3		
Reel Rotation Lever	Page 4-3		
Mower Unit Lifting lever	Page 4-4		
Brake Pedal	Page 4-5		
Diff-lock Pedal	Page 4-5		
Parking Brake Lever	Page 4-5		
Safety Device	Page 4-6		
Handling Instructions	Page 5-1		
Operations Before Service	Page 5-2		
Inspection Before Use	Page 5-2		
Adjustment before Work	Page 5-7		
Mounting/Dismounting	Page 5-8		
Start/Stop of Engine	Page 5-8		
Parking and Stopping	Page 5-8		
Move	Page 5-9		
Cutting Work	Page 5-9		
Transporting	Page 5-9		
Cleaning After Use	Page 5-9		
Maintenance	Page 6-1		
Precautions for Maintenance	Page 6-2		
Jacking Up The Machine	Page 6-2		
Inspection and Cleaning	Page 6-4		
Supplying Fluids	Page 6-6		
Greasing	Page 6-7		
Lubrication	Page 6-9		
Adjustment	Page 6-10		

LM180E

Contents

Safe Operating Practices Page 1-2

Training Page 1-2

Preparation Page 1-2

Operation Page 1-3

Maintenance Page 1-4

Storage Page 1-4



Safety

Failure to adequately follow these safety precautions may cause an accident resulting in injury or death.

Danger

This product is designed to ensure safe operation and has been tested and inspected thoroughly before shipment from the factory. The product is equipped with safety devices to prevent accidents.

However, whether the product demonstrates its original performance level depends on the manner in which it is operated and handled, as well as the manner in which it is managed on a daily basis.

Inappropriate use or management of the product may result in injury or death.

Observe the following safety instructions to ensure safe operation.

Safe Operating Practices

Training

1. Read this manual and other training material carefully.

Be familiar with the controls, safety signs, and the proper use of the equipment.

2. If the operator or mechanic can not read the language used in this manual, it is the owner's responsibility to explain this material to them.

3. All operators and mechanics should seek and obtain professional and practical instruction.

The owner is responsible for training the users.

Such instruction should emphasize:

- [1] The need for care and concentration when working with ride-on machines.

- [2] Control of a ride-on machine sliding on a slope will not be regained by the application of the brake.

The main reasons for loss of control are

- Insufficient wheel grip
- Being driven too fast
- Inadequate braking
- The type of machine is unsuitable for its task
- Lack of awareness of the effect of ground conditions, especially slopes
- Incorrect hitching and load distribution

4. Never allow children or people unfamiliar with these instructions to use or service the machine.

Local regulations may restrict the age of the operator.

5. The owner/user can prevent and is responsible for accidents or injuries occurring to themselves, other people, or property.
6. Keep in mind that the owner, operator, and mechanic are responsible for accidents or hazards occurring to other people or their property.
7. You can find additional safety information where needed throughout this manual.
8. Determine the left and right sides of the machine from the normal operating position.

Preparation

1. Evaluate the terrain to determine what accessories and attachments are needed to properly and safely perform the job. Only use accessories and attachments approved by the manufacturer.
2. While operating, always wear substantial footwear, long trousers, hard hat, safety glasses, mask, and ear protection. Long hair, loose clothing, or jewelry may get tangled in moving parts. Do not operate the equipment when barefoot or wearing open sandals.
3. Inspect the area where the equipment is to be used and remove all objects such as rocks, toys and wire which can be thrown by the machine.
4. Keep children out of the operating area and under the watchful care of a responsible adult other than the operator.
5. Exercise care in the handling of fuel.

Warning

Fuel is highly flammable.

Take the following precautions:

- [1] Store fuel in containers specifically designed for this purpose.
- [2] Add fuel before starting the engine. Never remove the cap of the fuel tank or add fuel while the engine is running or when the engine is hot.
- [3] Refuel outdoors only and do not smoke while refueling.

- [4] If fuel is spilled, do not attempt to start the engine but move the machine away from the area of spillage and avoid creating any source of ignition until petrol vapours have dissipated;
- [5] Replace all fuel tanks and container caps securely.
6. Check that operator's presence controls, safety switches and shields are attached and functioning properly.
Do not operate unless they are functioning properly.
7. If the brake operation is faulty, be sure to adjust or repair them before operating the machine.
8. Replace faulty mufflers.
9. On multi-cylinder/multi-reel machines, take care as rotating one cylinder/reel can cause other cylinders/reels to rotate.
12. Do not stop or start suddenly.
13. Look behind and down before backing up to be sure of a clear path.
14. Slow down and use caution when making turns and crossing roads and sidewalks.
15. Use care when approaching blind corners, shrubs, trees, or other objects that may obscure vision.
16. Do not take your eyes off the road ahead.
Do not operate the machine with no hands.
17. Remember there is no such thing as a safe slope.
Travel on grass slopes requires particular care.
To guard against overturning, follow these instructions.

Operation

1. Do not operate the machine under the influence of alcohol or drugs.
2. Do not operate the engine in a confined space where dangerous carbon monoxide fumes can collect.
3. Be sure all drives and shift are in neutral and parking brake is engaged before starting engine.
Only start engine from the operator's position.
Use seat belts if provided.
4. Do not change the engine governor settings or overspeed the engine.
Operating the engine at excessive speed may increase the hazard of personal injury.
5. Pay attention not to touch hot parts.
6. Never operate the machine with damaged guards, shields, or without safety protective devices in place.
Be sure all interlocks are attached, adjusted properly, and functioning properly.
7. Keep hands and feet away from the rotating parts.
8. Do not carry passengers.
9. Never operate while people, especially children, or pets are nearby.
10. Only operate in good light, keeping away from holes and hidden hazards.
11. Do not operate the machine when there is the risk of lightning.
- [1] Do not stop or start suddenly when going up or downhill.
- [2] Engage clutch slowly, always keep machine in gear, especially when traveling downhill.
- [3] Machine speeds should be kept low on slopes and during turns.
- [4] Stay alert for humps and hollows and other hidden hazards.
18. Never use the machine on a slope with an angle of gradient that is greater than that specified or in a place where there is a danger of the machine slipping.
19. Disengage drive to the cutting unit(s), when other than operating.
20. Do the following before leaving the operator's position.
 - [1] Stop on level ground.
 - [2] Disengage the all drives.
 - [3] Set the parking brake.
 - [4] Stop the engine.
21. Stop the engine in the following conditions.
 - [1] Before refuelling.
 - [2] Before making height or depth adjustment unless adjustment can be made from the operator's position.
 - [3] Before clearing blockages.
 - [4] Before checking, cleaning or working on the machine.
 - [5] After striking a foreign object or if an abnormal vibration occurs.
Inspect the machine for damage and make repairs before restarting and operating the equipment.

Safety

22. Reduce the throttle setting during engine run-out.
23. Do not direct discharge material toward anyone.
Avoid discharging material against a wall or obstruction.
Material may ricochet back toward the operator.
24. Take care when loading or unloading the machine into a trailer or a truck.
Load or unload the machine in a flat and safe place.
Before loading or unloading, set the parking brake on the truck or trailer, stop the engine, and chock the wheels.
When transporting the machine on a truck or a trailer, set the parking brake, stop the engine, and fasten the machine to the truck with a rope or other suitable restraining device that has sufficient strength.
When using a running board, select one with sufficient strength, length, and width and that will not cause the machine to slip.
25. Close the fuel valve before transporting the machine.
7. Keep hands and feet away from moving parts.
If possible, do not make adjustments with the engine running.
8. Make sure that parts such as wires are not touching each other and that their covers have not come off.
9. Keep all parts in good working condition and all hardware tightened.
Replace all worn or damaged decals.
10. Keep all nuts, bolts and screws tight to be sure the equipment is in safe working condition.
11. Carefully release pressure from components with stored energy.
12. Use care when checking the cylinders/reels and bed knives.
Wear gloves and use caution when servicing them.
13. Be careful during adjustment of the machine to prevent entrapment of the fingers between moving blades and fixed parts of the machine.
14. On multi-cylinder/multi-reel machines, take care as rotating one cylinder/reel can cause other cylinders/reels to rotate.
15. If the fuel tank has to be drained, do this outdoors.

Maintenance

1. Never allow untrained personnel to service machine.
2. Implement the following work before adjusting, cleaning or repairing.
 - [1] Stop the machine on level ground.
 - [2] Disengage drive to the cutting unit(s).
 - [3] Lower the cutting unit(s) and/or attachment(s).
 - [4] Set the parking brake.
 - [5] Stop the engine.
 - [6] Disconnect spark plug wire.
 - [7] Wait for all movement to stop.
3. Allow the engine/muffler to cool before checking/maintenance.
4. To reduce the fire hazard, keep hot parts such as the engine and silencer/muffler, and fuel storage area free of grass, leaves, or excessive grease.
Clean up oil or fuel spillage.
5. Appropriately manage and correctly use the tools necessary for servicing or adjusting the machine.
6. Use jack stands to support components when required.

Storage

1. When machine is to be parked, stored, or left unattended, lower the cutting unit(s) and/or attachment(s) unless a positive mechanical lock is provided.
2. Allow the engine to cool before storing in any enclosure.
3. Only cover the machine with a sheet after hot parts have sufficiently cooled down.
4. Never store the equipment with fuel in the tank inside a building where fumes may reach an open flame or spark.
5. If the engine is provided with a shut-off valve, shut off valve while storing or transporting.
6. Do not store fuel near flames.

Recycle and Waste Disposal Page 2-2

About RecyclePage 2-2

About Waste Disposal Page 2-2

Disposal

Disposal

Recycle and Waste Disposal

About Recycle

Recycling battery etc. is recommended for environmental conservation and economical use of resources.

It may be required by local laws.

About Waste Disposal

Make sure that waste generated when servicing or repairing the machine is disposed of in accordance with local regulations. (e.g. waste oil, antifreeze, rubber products, and wires etc.)

Specifications Page 3-2

Specifications	Page 3-2
Sound Pressure Level	Page 3-3
Sound Power Level	Page 3-3
Vibration Level	Page 3-3
Carbon Dioxide (CO ₂) Emissions	Page 3-3

Names of Each Section Page 3-4

Regulation Decals Page 3-4

Positions of Regulation Decals	Page 3-4
Description of Regulation Decals	Page 3-4

Safety Signs and Instruction Signs Page 3-6

About Safety Signs and Instruction Signs	Page 3-6
Positions of Safety Decals and Instruction Decals	Page 3-6
Description of Safety Decals and Instruction Decals	Page 3-6

Operation Decals Page 3-8

Positions of Operation Decals	Page 3-8
Description of Operation Decals	Page 3-8

Product Overview

Specifications

Specifications

Model		LM180E	
Name		3-Unit Reel Mower	
Dimensions	Total length	215 cm	84.65 in
	Total width	During operation	208 cm 81.89 in
		During transport	185 cm 72.83 in
	Total height	Steering wheel	102 cm 40.16 in
Weight	Machine (empty fuel tank)	381 kg	839.95 lb
Minimum turning radius		230 cm	90.55 in
Engine	Model	MITSUBISHI GB300LN	
	Type	Air-Cooled, 4-Cycle, Slant Single-Cylinder, Horizontal P.T.O. Shaft, OHC Gasoline Engine	
	Total displacement	296 cm ³ (0.296 L)	18.06 cu.in.
	Maximum output	7.3 kW (10.0 PS)/2,000 rpm	
	Rated output	5.5 kW (7.5 PS)/1,800 rpm	
Fuel tank capacity	Gasoline 6.0 dm ³ (6.0 L)	Gasoline 1.59 U.S.gals	
Fuel consumption	315 g/kW · h (rated output)	428 g/PS · h (rated output)	
Engine oil capacity	1.0 dm ³ (1.0 L)	0.26 U.S.gals	
Coolant volume	-		
Hydraulic tank capacity	-		
Transmission oil capacity	2.0 dm ³ (2.0 L)	0.53 U.S.gals	
Operating width (Mowing width)	188 cm	74.02 in	
Operating height (Mowing height)	13.0 - 15.0 mm	0.51 - 1.97 in	
Number of Blades	5,7		
Drive	Traveling	Mechanical	
	Mowing	Mechanical	
Speed (HST)	-		
Speed (Mechanical)	Forward	1st	3.1 km/h 1.93 mph
		2nd	6.4 km/h 3.98 mph
		3rd	9.4 km/h 5.84 mph
	Reverse	1st	3.1 km/h 1.93 mph
Efficiency	9,630 m ² /h (6.4 km/h x Mowing width x 0.8)	2.38 acres/hour (3.98 mph x Mowing width x 0.8)	
Maximum inclination for operation	15 degrees		
Tire size	Front wheel	4.00-5	
	Rear wheel	18 x 8.50-8	
Tire pneumatic pressure	Front wheel	200 kPa (2.0 kgf/cm ²)	29 psi
	Rear wheel	80 kPa (0.8 kgf/cm ²)	12 psi
Battery	-		
Engine plug	BR5ES		

The factory default maximum engine rpm is 1,800 rpm.

Sound Pressure Level

Sound Pressure Level

This machine was confirmed to have a continuous A-weighted sound pressure level of 89dB by measuring identical machines in accordance with the procedure specified in ISO 5395-1:2013.

Sound Power Level

Sound Power Level

This machine was confirmed to have a sound power level of 103 dB by measuring identical machines in accordance with the procedure specified in ISO 5395-1:2013.

Vibration Level

Hand-Arm Vibration

This machine was confirmed to transmit a vibration level of 2.86 m/s² to hands and arms by measuring identical machines in accordance with the procedure specified in ISO 5395-1:2013.

Whole Body Vibration

This machine was confirmed to transmit a vibration level of 0.65 m/s² to the whole body by measuring identical machines in accordance with the procedure specified in ISO 5395-1:2013.

Carbon Dioxide (CO₂) Emissions

The CO₂ value on the engine of this machine is 930 g/kWh.

This CO₂ measurement results from testing over a fixed test cycle under laboratory conditions of a(an) (parent) engine representative of the engine type (engine family) and shall not imply or express any guarantee of the performance of a particular engine.

Product Overview

Names of Each Section

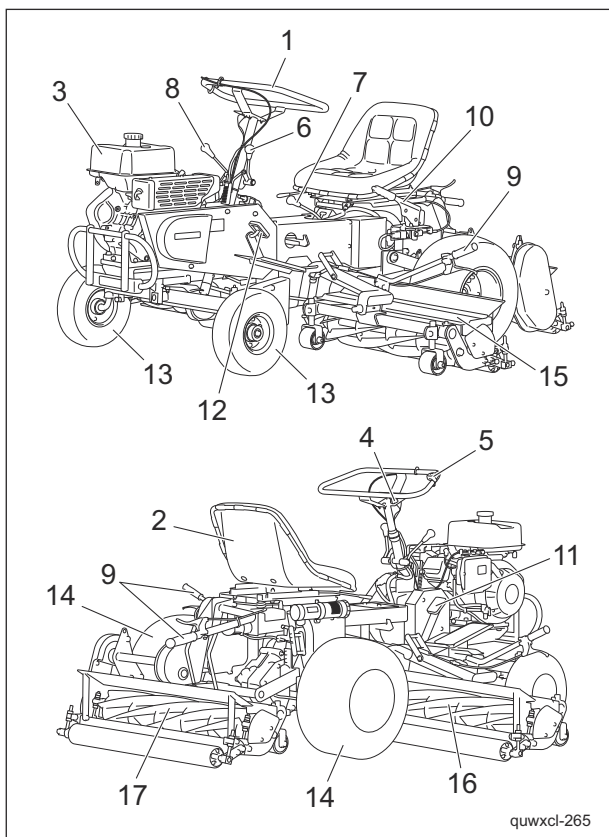

Names of Each Section_001

1	Steering handle
2	Seat
3	Engine
4	Engine switch
5	Throttle lever
6	Traveling clutch lever
7	Change lever
8	Reel rotation lever
9	Mower unit lifting lever
10	Parking brake lever
11	Brake pedal
12	Diff-lock pedal
13	Front tire
14	Rear tire
15	Left mower unit
16	Right mower unit
17	Rear mower unit

Regulation Decals

Positions of Regulation Decals

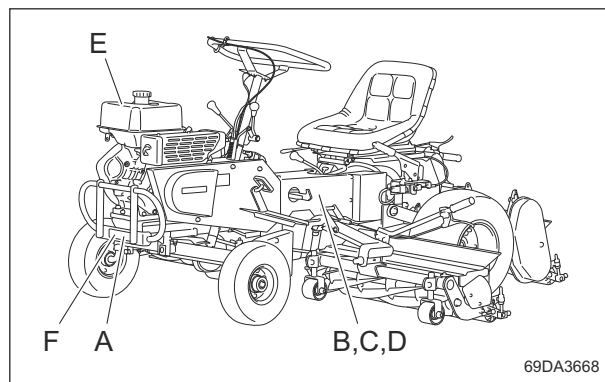

Positions of Regulation Decals_001

A	Serial number plate
B	Specification decal
C	CE mark
D	UKCA mark (- #21081)
E	Noise emission decal
F	Year of manufacture decal

Description of Regulation Decals

Serial Number Plate

The serial number plate indicates the model and serial number of the machine.

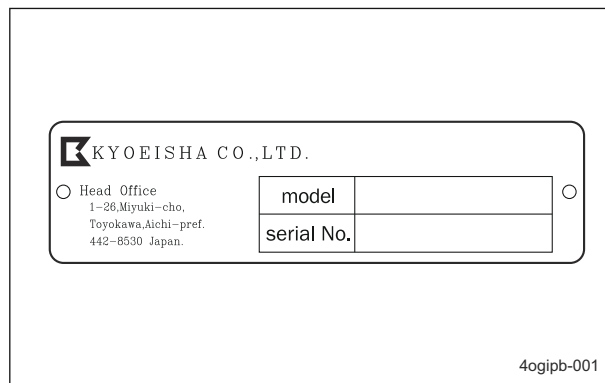

Serial Number Plate_001

Specification Decal

(For EU)
The Specification decal indicates the model and weight, etc.

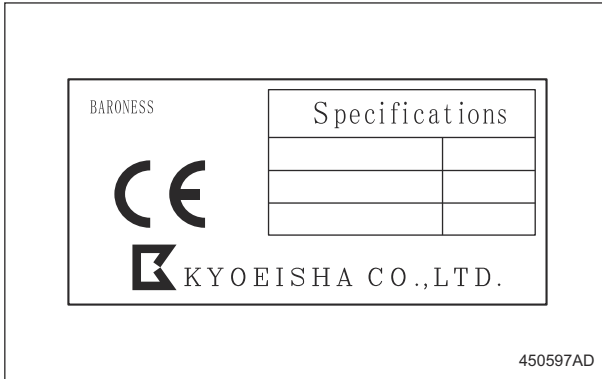

Specification Decal_001

Noise Emission Decal

(For EU)
The noise emission decal indicates the sound power level determined by measuring identical machines in accordance with the procedure specified in the regulations of EU.

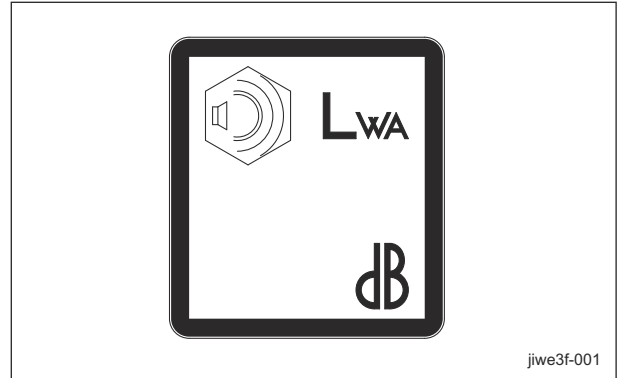

Noise Emission Decal_001

CE Mark

(For EU)
CE mark indicates that the machine sold in the EU nations complies with the EU requirements.

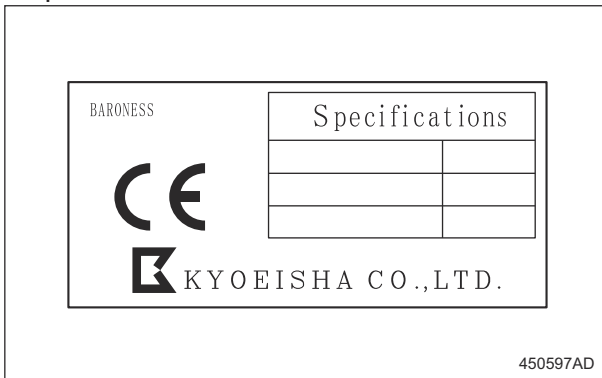

CE Mark_001

Year of Manufacture Decal

(For EU)
The year of manufacture decal indicates the year when this machine was manufactured.

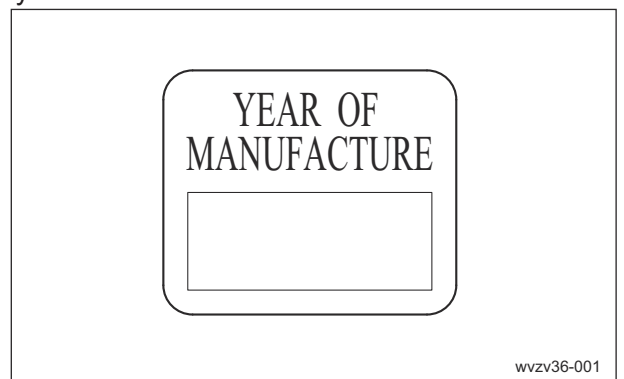

Year of Manufacture Decal_001

UKCA Mark

(For UK)
UKCA mark indicates that the machine sold in the UK complies with the UK requirements.



UKCA Mark_001

Product Overview

Safety Signs and Instruction Signs

About Safety Signs and Instruction Signs

Important

Safety decals and instruction decals are attached to this product. Make sure that they are preserved in their entirety. If they are damaged, become dirty, or peel off, replace them with new ones.

Part numbers for decals that need to be replaced are listed in the parts catalog. Order them from a Baroness dealer or Kyoeshia.

Positions of Safety Decals and Instruction Decals

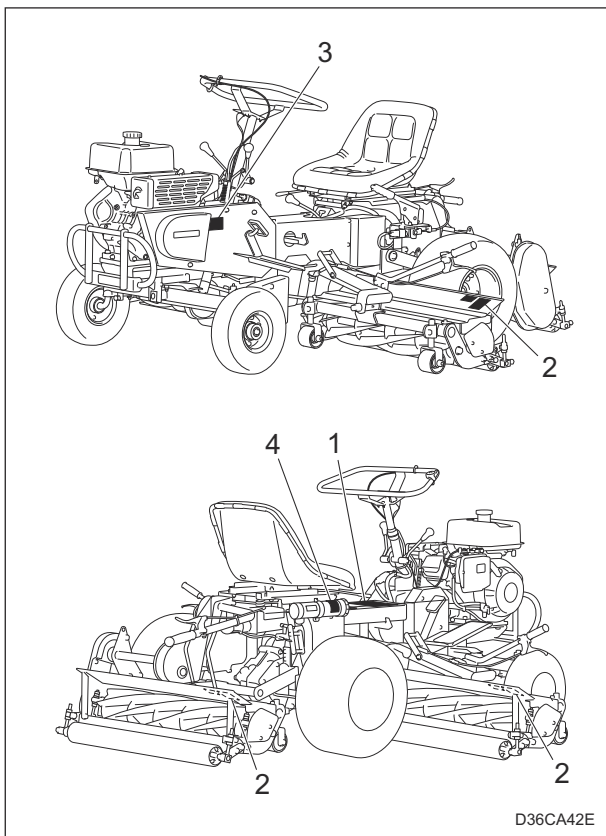

Positions of Safety Decals and Instruction Decals_001

1	Operation decal
2	Caution to mutilation decal
3	Caution to rotating object decal
4	Decal on reading owner's operating manual (- #21081)

Description of Safety Decals and Instruction Decals

Operation Decal

LM180E-1001Z0
STICKER, OPERATION

1.

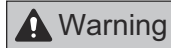

Read the Owner's Operating Manual.

2.



Flying objects - Be sure that people around the machine keep a safe distance away.

3.

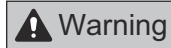

Rollover - Do not work on slopes of 15 degrees or more. When you descend a slope, lower the mower units and drive at low speed.

4.

Noise - Wear ear protection.

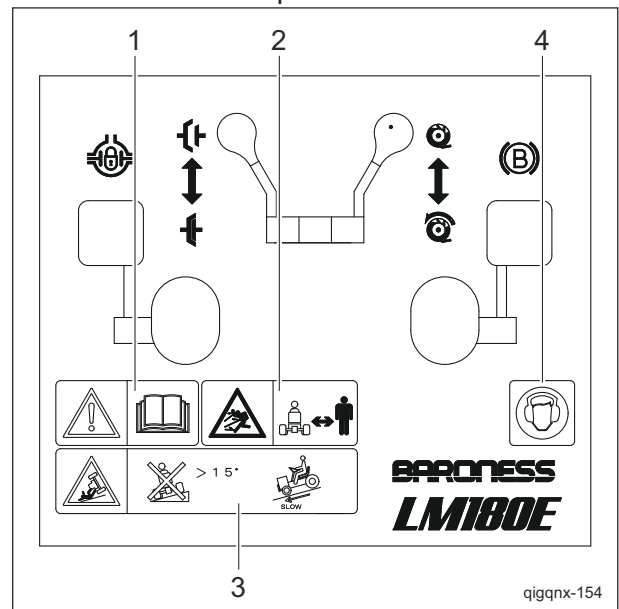

Operation Decal_001

Caution to Mutilation Decal

K4205001600
DECAL, CAUTION TO MUTILATION

 Warning

May cut your hand or leg - Stop the cutter rotation and engine. Otherwise you may get injured.

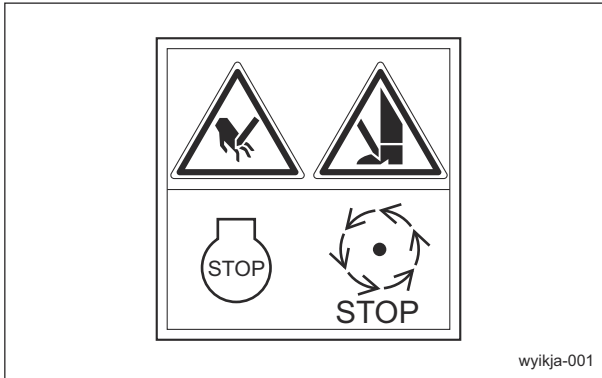

Caution to Mutilation Decal_001

Decal on Reading Owner's Operating Manual

K4205001560
Decal, read Owner's Operating Manual

 Warning

Read the Owner's Operating Manual.

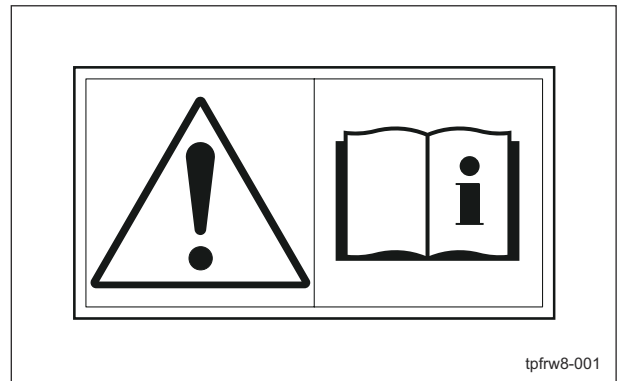

Decal on Reading Owner's Operating Manual_001

Caution to Rotating Object Decal

K4205001530
Decal, caution to rotating object

 Warning

Watch for rotating parts - Keep your hands away from the belts while the engine is running.

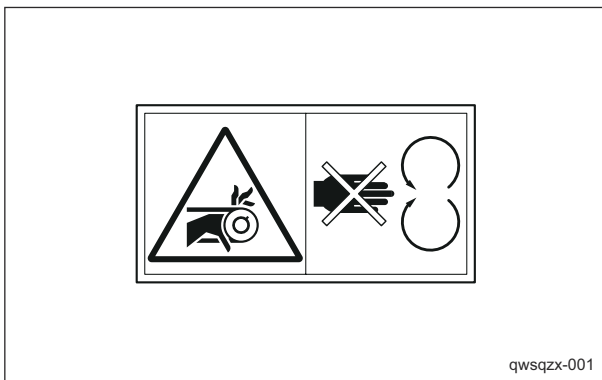

Caution to Rotating Object Decal_001

Product Overview

Operation Decals

Positions of Operation Decals

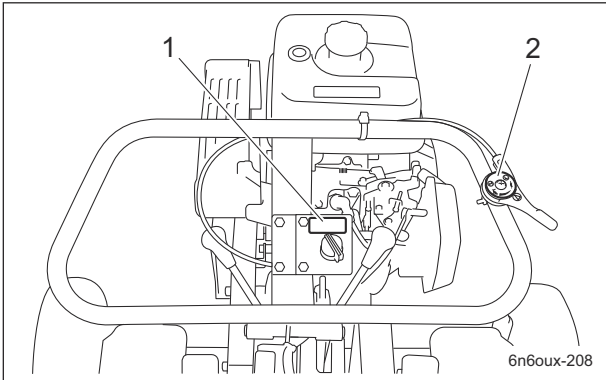

Positions of Operation Decals_001

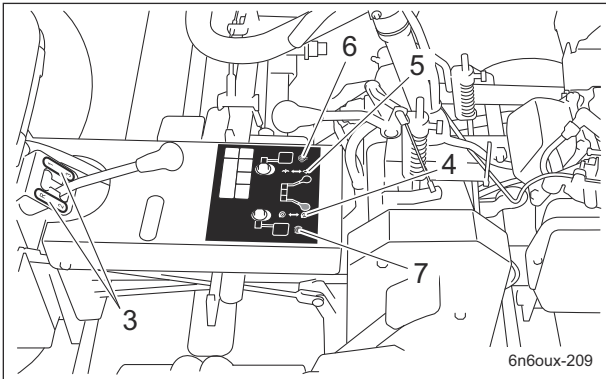

Positions of Operation Decals_002

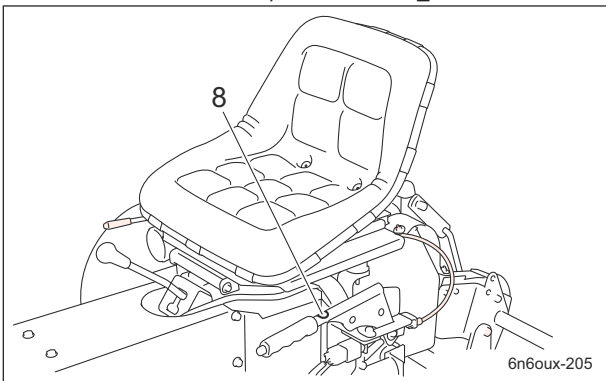

Positions of Operation Decals_003

1	Engine switch mark
2	Engine rotation mark
3	Change mark
4	Reel rotation mark
5	Clutch operation mark
6	Differential lock mark
7	Brake mark
8	Brake mark

Description of Operation Decals

Engine Switch Mark

K4203000670

Decal, engine switch

This indicates the engine switch positions.

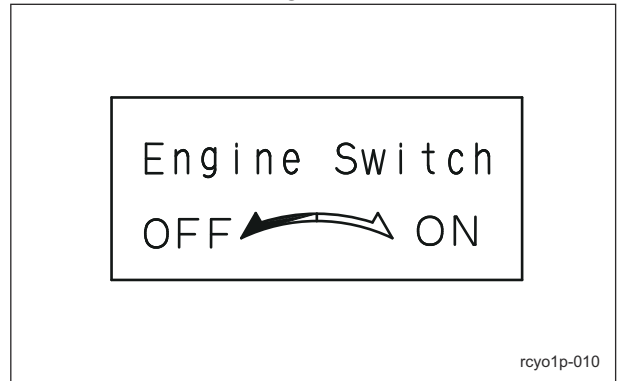

Engine Switch Mark_001

Engine Rotation Mark

-

Engine rotation mark

This indicates low/high speed of engine rotation.

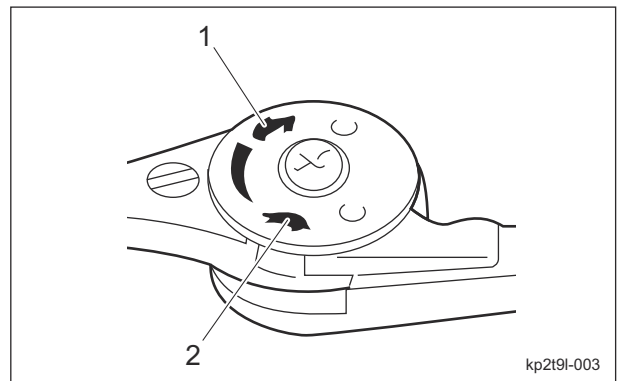

Engine Rotation Mark_001

1	High speed
2	Low speed

Change Mark

LM180E-0802Z0
 DECAL, SHIFTING
 This indicates the positions of the change lever.

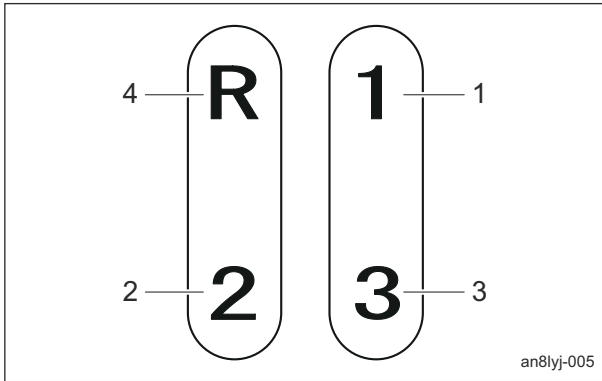

Change Mark_001

1	Forward (1st speed)
2	Forward (2nd speed)
3	Forward (3rd speed)
4	Reverse

Reel Rotation Mark

Reel rotation mark
 It illustrates Rotation/Stop of the reel cutter (cutting cylinder).

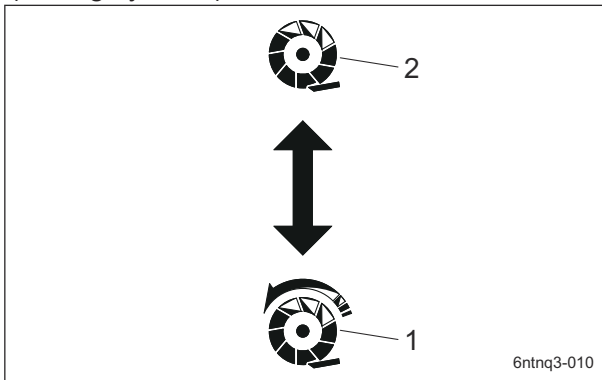

Reel Rotation Mark_001

1	Rotation
2	Stop

Clutch Operation Mark

Clutch operation mark
 This illustrates "Engage/Disengage" of the traveling clutch.

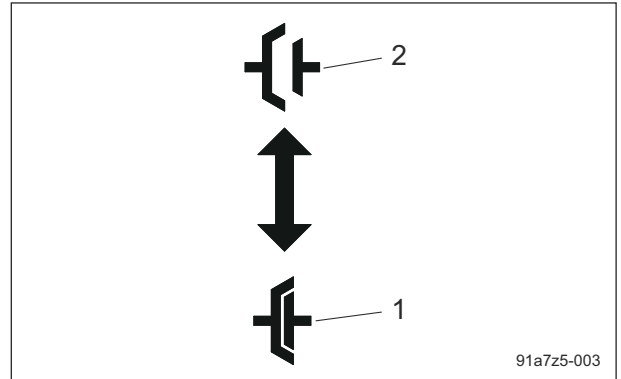

Clutch Operation Mark_001

1	Engage
2	Disengage

Brake Mark

Brake mark
 This indicates brake pedal.

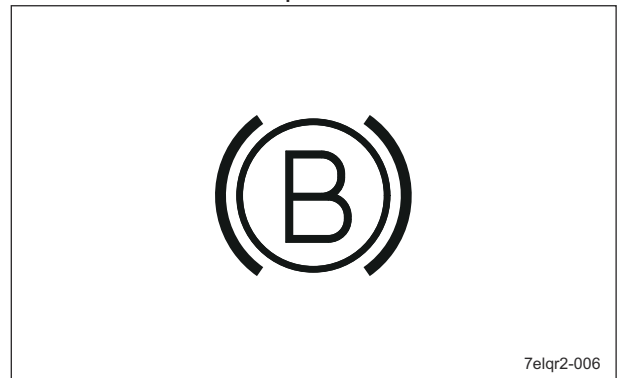

Brake Mark_001

Differential Lock Mark

Differential Lock Mark
 This indicates the differential lock pedal.

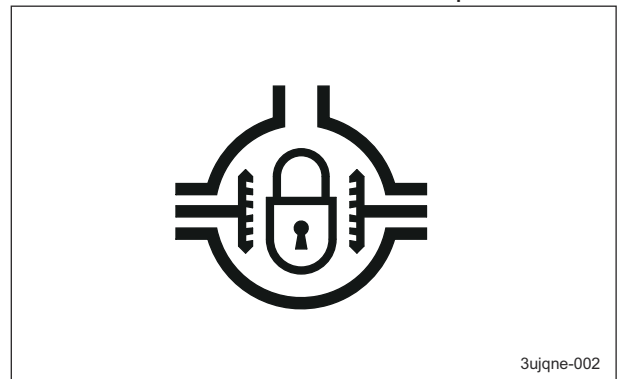

Differential Lock Mark_001

Product Overview

Brake Mark

K4209001200

DECAL, BRAKE

It illustrates the locking position for the parking brake.



Brake Mark_001

Description of Functions

Engine Switch	Page 4-2
Throttle Lever	Page 4-2
Change Lever	Page 4-2
Traveling Clutch Lever	Page 4-3
Reel Rotation Lever	Page 4-3
Mower Unit Lifting lever	Page 4-4
Left and Right Mower Units	Page 4-4
Rear Mower Unit	Page 4-4
Brake Pedal	Page 4-5
Diff-lock Pedal	Page 4-5
Parking Brake Lever	Page 4-5
Safety Device	Page 4-6
Interlock System	Page 4-6

Description of Functions

Engine Switch

The engine switch is located in the handle. To start the engine, set the engine switch to the "ON" position, and to stop it, set to the "OFF" position.

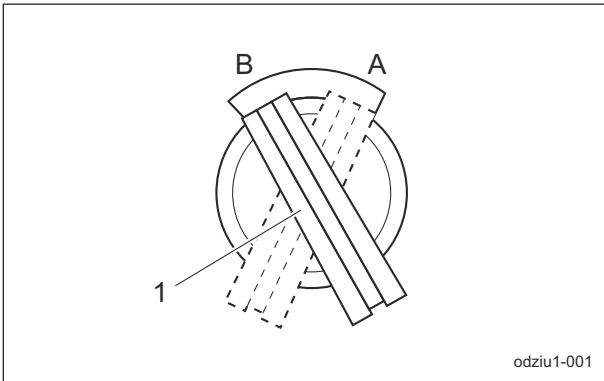

Engine Switch_001

1	Engine switch
A	ON
B	OFF

Throttle Lever

The throttle lever is located to the right of the steering handle and enables you to adjust the engine rpm. Move the throttle lever toward the "High speed" position to increase the engine rpm, and toward the "Low speed" position to reduce the rpm.

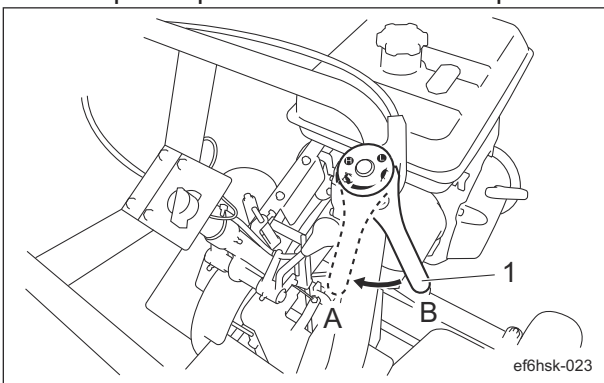

Throttle Lever-001

1	Throttle lever
A	High speed
B	Low speed

Change Lever

Important

Do not change the lever position during traveling. Otherwise, the transmission will be damaged.

The change lever is a transmission device. It was adapted from a direct change system. To change the speed, park the machine on level ground, and then engage the lever in the desired position. When the lever is not tilted to engage, it is in neutral.

Forward	1	3.1 km/h
	2	6.4 km/h
	3	9.4 km/h
Backward	R	3.1 km/h

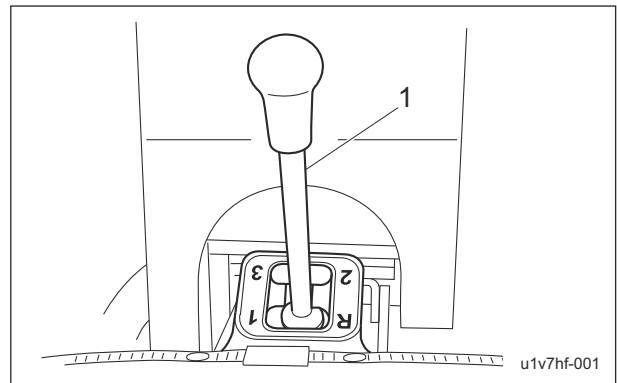

Change Lever_001

1	Change lever
---	--------------

Description of Functions

Traveling Clutch Lever

Warning

Be careful of the machine suddenly accelerating when the machine starts to travel if the throttle lever is set to the "High speed" position.

Warning

The machine may suddenly accelerate if the clutch is abruptly operated.

To prevent sudden acceleration, tilt the traveling clutch lever back slowly. Start the machine while allowing the belt to slip in the same way as clutch-slipping. When the traveling clutch is set to the "ON" position, the reel cutter automatically rotates when the mower unit is lowered. When the traveling clutch is set to the "OFF" position, the reel cutter does not rotate, even if the mower unit is lowered.

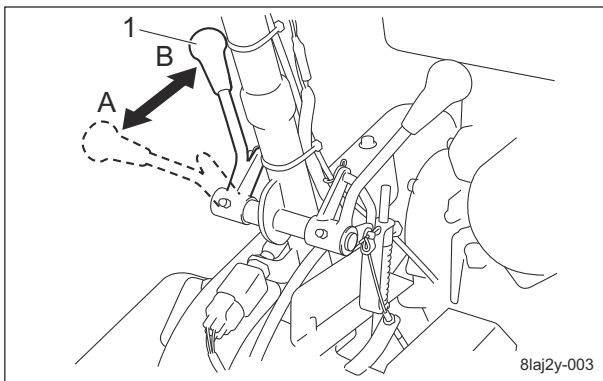

Traveling Clutch Lever_001

1	Traveling clutch lever
A	ON
B	OFF

Important

Slowly set the reel rotation lever to the engaged position. If the clutch is quickly engaged, the engine may stall.

Important

Unless both left and right mower units have been lowered all the way, you are not able to operate the reel rotation lever.

When the reel rotation lever is tilted back, the reel cutter (cutting cylinder) rotates. When the reel rotation lever is tilted forward, the reel cutter (cutting cylinder) stops rotating.

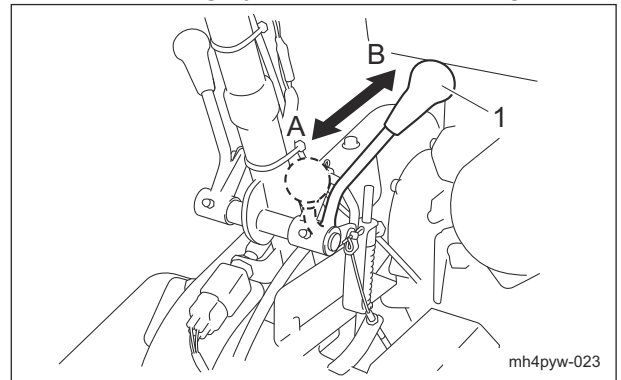

Reel Rotation Lever_001

1	Reel rotation lever
A	Rotation
B	Stop

Reel Rotation Lever

Caution

Set the reel rotation lever to the engaged position immediately before mowing. At all other times, be sure to leave the reel clutch lever in the disengaged position.

Description of Functions

Mower Unit Lifting lever

Left and Right Mower Units

⚠ Caution

Before raising or lowering the mower units, make sure that there are no people around the machine.

Important

If the reel rotation lever is set to "Rotation," you will be unable to raise the mower units.

To lower the left and right mower units, squeeze the clutch lever and slowly move the mower unit lifting lever down.

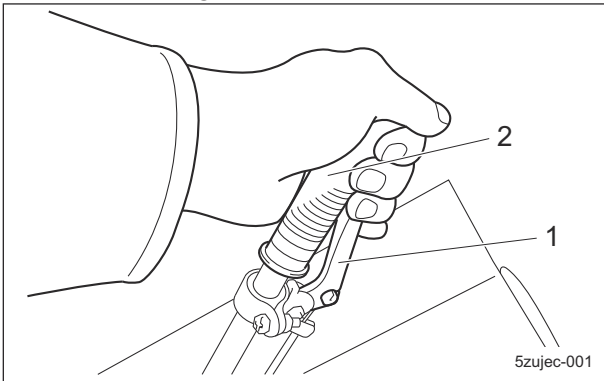

Left and Right Mower Units_001

1	Clutch lever
2	Mower unit lifting lever

To raise the left and right mower units, raise the mower unit lifting lever slowly until the hook metal fitting is secured by the hook.

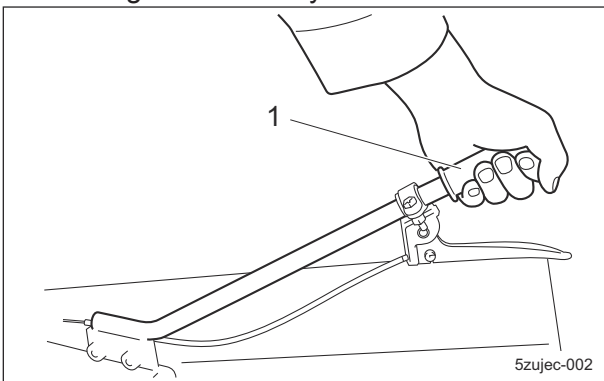

Left and Right Mower Units_002

1	Mower unit lifting lever
---	--------------------------

Rear Mower Unit

Important

Before raising or lowering the mower units, make sure that there are no people around the machine.

To lower the rear mower unit, squeeze the clutch lever and slowly move the mower unit lifting lever down.

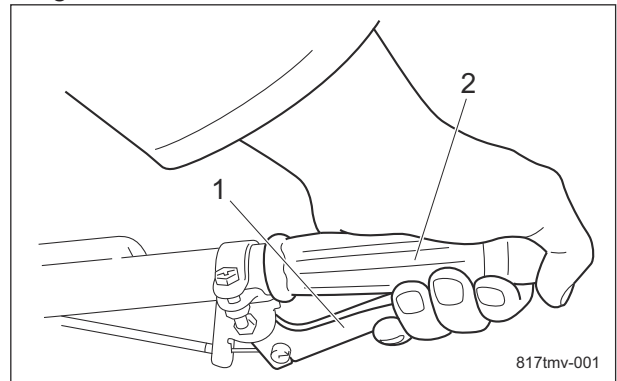

Rear Mower Unit_001

1	Clutch lever
2	Mower unit lifting lever

To raise the rear mower units, raise the mower unit lifting lever slowly, and then tilt it fully forward.

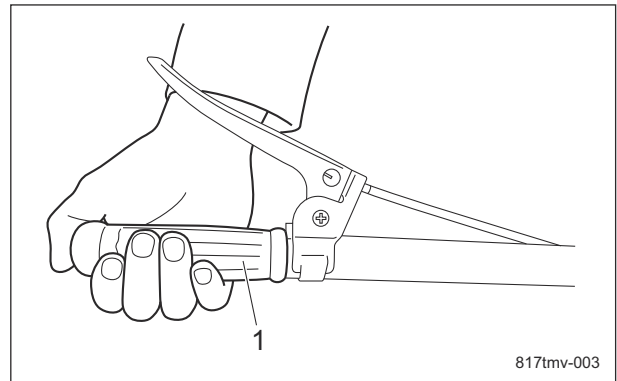

Rear Mower Unit_002

1	Mower unit lifting lever
---	--------------------------

Description of Functions

Brake Pedal

The brake pedal is located in the right foot area. In order to stop the machine, depress the brake pedal with your right foot until the pedal hits the pedal stopper.

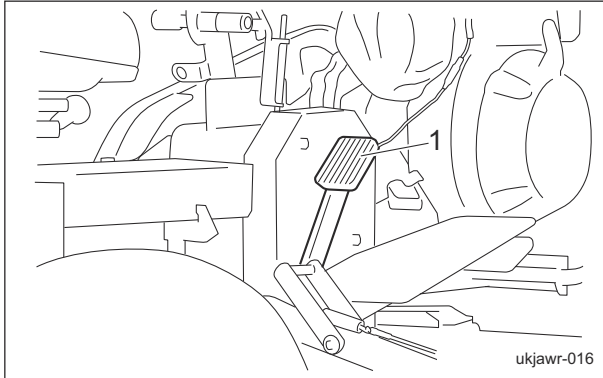

Brake Pedal_001

1	Brake pedal
---	-------------

Diff-lock Pedal

The diff-lock pedal is located in the left foot area. If you press the diff-lock pedal, the differential device is locked to enhance linearity, thus preventing slipping.

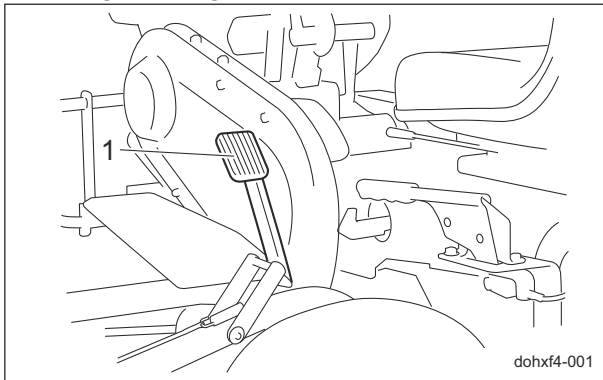

Diff-lock Pedal_001

1	Diff-lock pedal
---	-----------------

Parking Brake Lever

Caution

Never park the machine on a slope.

Important

Be sure to release the parking brake before driving. It will result in the brakes malfunctioning.

The parking brake lever is located on the left side of the seat.

To park the machine, pull the parking brake lever completely.

To release the parking brake, press the push button while lowering the parking brake lever all the way to its resting position.

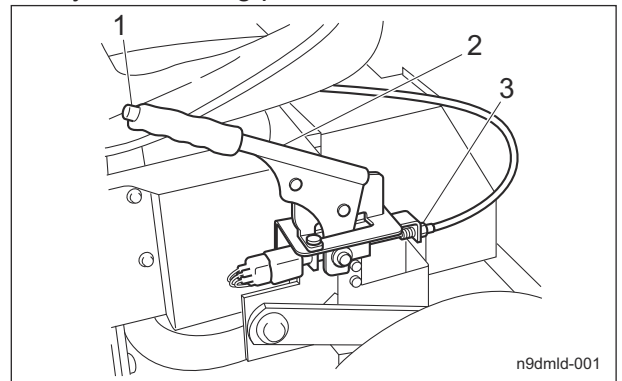

Parking Brake Lever_001

1	Push button
2	Parking brake lever
3	Adjustment bolt

Description of Functions

Safety Device

Interlock System

This machine has the safety device for starting and stopping the engine.

1. As for starting the engine, the safety device prevents the engine from starting unless it meets each of the following three conditions.
 - An operator is sitting on the seat.
 - The parking brake lever is pulled.
 - The traveling clutch lever is in the "OFF" position.
2. In the event the operator leaves the seat with the parking brake not applied and the engine running, the safety device will be activated and will stop the engine.
3. In the event the operator leaves the seat with the parking brake applied and the engine running, the safety device will be activated and will stop the engine under the following condition.
 - The traveling clutch lever is in the "ON" position.

Operations Before ServicePage 5-2

Opening and Closing of Seat
Mounting PlatePage 5-2

Inspection Before UsePage 5-2

EnginePage 5-2
Main Vehicle Page 5-4
Mower UnitPage 5-6

Adjustment before Work Page 5-7

Main Vehicle Page 5-7

Mounting/DismountingPage 5-8

Mounting/Dismounting Procedure Page 5-8

Start/Stop of Engine Page 5-8

Procedure to Start Engine Page 5-8
Procedure to Stop Engine Page 5-8

Parking and StoppingPage 5-8

Leaving the machine Page 5-8

MovePage 5-9

Traveling Operation Page 5-9

Cutting Work Page 5-9

Cutting Operation Page 5-9

TransportingPage 5-9

Transporting Procedure Page 5-9

Cleaning After UsePage 5-9

EnginePage 5-10
Mower UnitPage 5-10

Handling Instructions

Operations Before Service

The following sections describe the preparatory works required before performing the services including inspection, adjustment, cleaning, maintenance and repair.

Opening and Closing of Seat Mounting Plate

⚠ Caution

When opening and closing the seat mounting plate, be careful not to pinch your hands.

1. Bring the seat to the backmost position.
2. Tilt the seat forward to open the seat mounting plate.

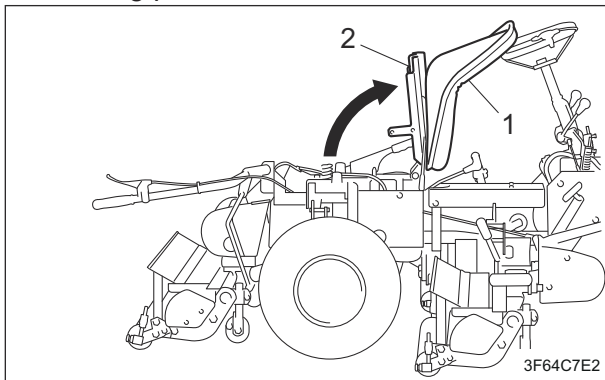

Opening and Closing of Seat Mounting Plate_001

1	Seat
2	Seat mounting plate

3. For closing, lower the seat slowly.

Inspection Before Use

The purpose of the machine inspection is to:

- Prevent accidents
- Prevent damage to the machine
- Maintain machine performance

Detecting machine malfunctions early helps prevent unexpected problems from occurring. If you detect any abnormalities with the machine, immediately perform maintenance or repairs.

Engine

Inspection of Engine Oil

Important

Securely tighten the oil level gauge.

1. Stop the engine, wait 10 to 20 minutes for the engine to cool down, and then check the oil level.
2. Position the machine so that the engine is level, and then check the engine oil level without tightening the oil level gauge in the oil filling port.

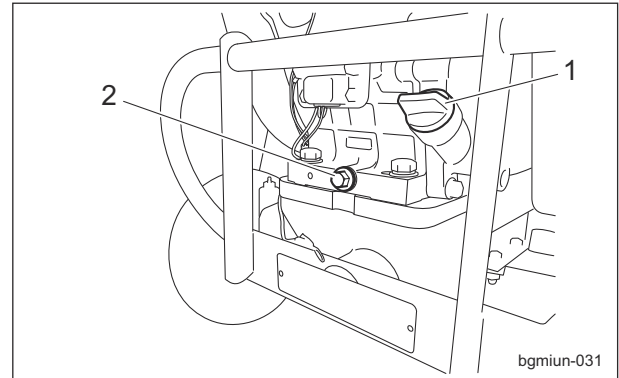

Inspection of Engine Oil_001

1	Oil level gauge (oil filling port)
2	Drain plug

3. The appropriate engine oil level should be between the upper and lower limit lines on the gauge.

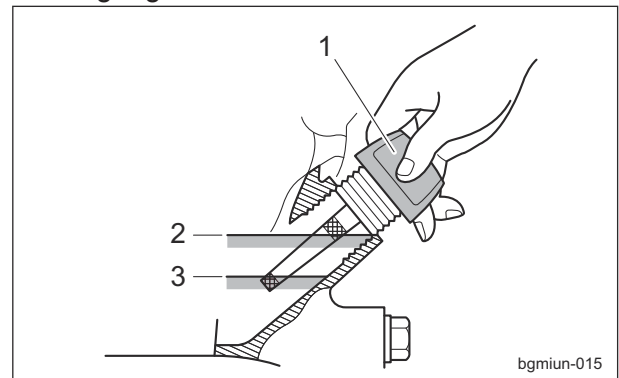

Inspection of Engine Oil_002

1	Oil level gauge
2	Upper limit
3	Lower limit

Handling Instructions

Inspection of Fuel Quantity

With the machine on a level surface, observe the fuel gauge on the fuel tank to check the fuel level.

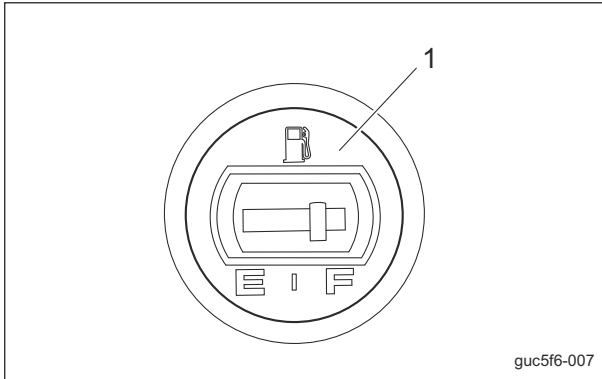

Inspection of Fuel Quantity_001

1	Fuel gauge
---	------------

Supply of Fuel

Warning

Do not supply fuel above the FULL level of the fuel gauge.
If you supply too much fuel, it might overflow from the tank cap when you travel or work on a slope.

Warning

Keep away from fire while refueling.
Do not smoke while refueling.

Warning

Supply fuel after stopping the engine and allowing it to cool down completely.

Caution

Be sure not to touch hot surfaces.

If the fuel gauge, located on the fuel tank, indicates a level close to EMPTY, supply fuel (gasoline) at your earliest convenience. The fuel tank capacity is approximately 6.0 dm³ (6.0 L).

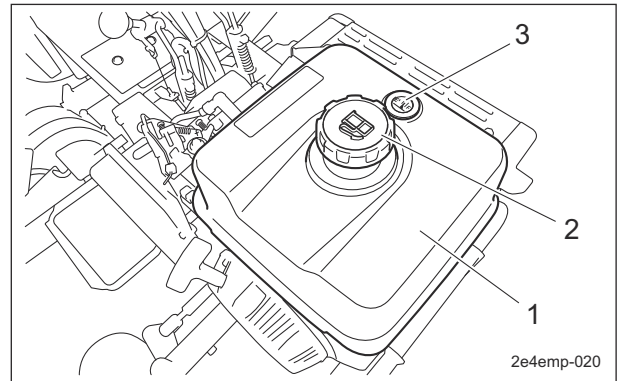

Supply of Fuel_001

1	Fuel tank
2	Tank cap
3	Fuel gauge

Inspection of Air Cleaner

1. Make sure that there is no damage to the air cleaner.
2. Make sure that the air cleaner element is not contaminated.

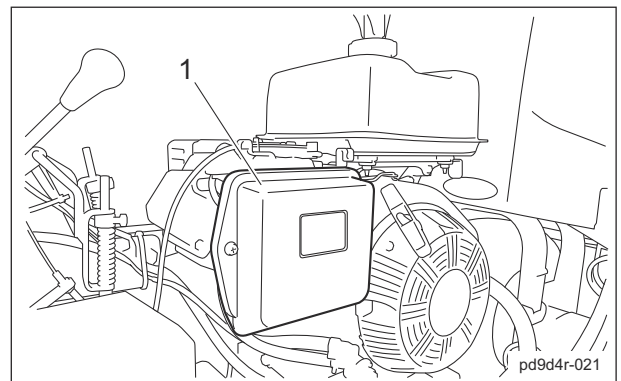

Inspection of Air Cleaner_001

1	Air cleaner
---	-------------

Inspection of Fuel Strainer

1. Make sure that there is no fuel leakage.
2. Make sure that the fuel strainer is not damaged or dirty.

Handling Instructions

Inspection of Liquid Leakage

Important

After approximately 50 hours of operation, some tightened portions may be loosened and liquid such as oil may leak. Be sure to retighten the parts.

Important

If liquid leakage found, repair it before operation. Ignoring leakage will cause further trouble.

1. Check the bottom of the machine for leakage of liquid such as oil, water, etc.
2. Locate the leakage and identify the type of liquid.

Inspection of Engine-Associated Parts

Caution

Perform operations after the engine and other parts have sufficiently cooled. Otherwise, you may suffer burns.

1. Check for damages and dirt.
2. Check the mount for looseness and cracks.
3. Check for liquid leakage.
4. Check on and around the muffler for grass clippings and flammable materials.
5. Check on and around the cooling fins and recoil starter for grass clippings and flammable materials.

Inspection of Bolts and Nuts

Important

The bolts and nuts may be loosened at the earlier stage of the use. Be sure to retighten or replace before operating the machine whenever there is any abnormality.

1. Check the bolts and nuts for looseness and coming off.
2. Check the bolts and nuts for cracks and damages.
3. Check the bolts and nuts for rust.
4. Check around the bolts and nuts for traces of rust fluid.

5. Check for unequal bolt length.
6. Check the bolts and nuts for stripped threads and abrasion.

Main Vehicle

Inspection of Tires

1. Check the pneumatic pressure of the tires.
2. Make sure that there are no cracks, damage or abnormal wear on the tires.

Tire size	Pneumatic pressure	
Front wheel (4.00 - 5)	200 kPa (2.0 kgf/cm ²)	29 psi
Rear wheel (8.50 - 8)	80 kPa (0.8 kgf/cm ²)	12 psi

Inspection of Covers

Warning

If you have removed the covers during inspection, be sure to securely install them in their original positions.

If a cover remains removed, the operator may come into contact with rotating parts or belts and foreign objects may fly off, possibly resulting in injuries.

1. Make sure that there is no wear or deterioration of the reel cover and all other covers.
2. Make sure that there is no damage to the reel cover and all other covers.
3. Make sure that there is no interference with moving parts due to deformation of the reel cover and all other covers.
4. Make sure that the reel cover and all other covers are installed in their appropriate positions.

Inspection of Wire

1. Make sure that the wire is not cracked or damaged.
2. Make sure that the wire is not worn.
3. Make sure that the wire is not crushed.
4. Make sure that the wire is not bent.
5. Make sure that the wire is not corroded or rusted.

Handling Instructions

Inspection of Brake Pedal

1. Make sure that there is no play in the pedal.
2. Make sure that the pedal moves smoothly.
3. Make sure that there is no abnormal sound when the pedal is depressed.
4. Make sure that the pedal does not touch the floorboard when the pedal is depressed.

Inspection of Brake Lever

1. Check the brake lever moves smoothly.
 - [1] Pull the brake lever.
 - [2] Press the push button and release the brake lever.
2. Check there is no abnormal sound when the brake lever is moved.
3. Check the brake is applied when you pull the brake lever.

Inspection of Brake

1. Apply the parking brake.
2. Set the change lever to the "Neutral" position.
3. Make sure that the machine does not move (brake is applied) when the machine is pushed back and forth.

Inspection of Diff-Lock Pedal

1. Make sure that there is no play in the pedal.
2. Make sure that the pedal moves smoothly.
3. Make sure that there is no abnormal sound when the pedal is depressed.

Inspection of Clutch Lever

1. Make sure that there is no play in the lever.
2. Make sure that the lever moves smoothly.
3. Make sure that there is no abnormal sound when the lever is moved.

Inspection of Reel Rotation Lever

1. Make sure that there is no play in the lever.
2. Make sure that the lever moves smoothly.
3. Make sure that there is no abnormal sound when the lever is moved.

Inspection of Mower Stopper

1. Lower the left and right mower units.

2. Make sure that the mower stopper moves to the appropriate position when the reel rotation lever is set to the "ON" position.

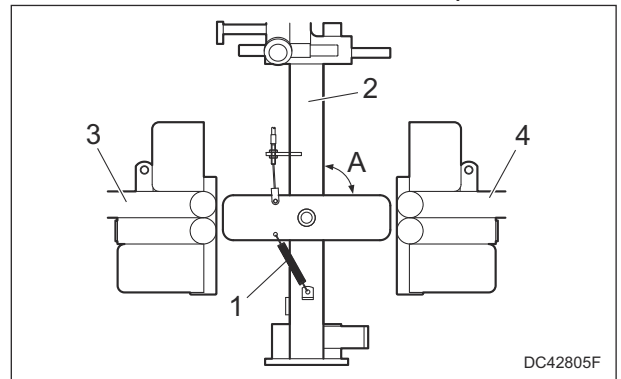

Inspection of Mower Stopper_001

1	Mower stopper
2	Frame
3	Left mower lifting arm
4	Right mower lifting arm
A	90 degrees

Inspection of Change Lever

1. Make sure that there is no play in the lever.
2. Make sure that the lever moves smoothly.
3. Make sure that there is no abnormal sound when the lever is moved.

Inspection of Steering Handle

1. Make sure that there is no play in the steering handle.
2. Make sure that the steering handle turns smoothly when it is turned.
3. Make sure that there is no abnormal sound when the steering handle is turned.
4. Check the direction of tires when the steering handle is turned.
 - [1] Start the engine.
 - [2] Make sure that the rear tire turns left when the steering handle is turned right.
 - [3] Make sure that the rear tire turns right when the steering handle is turned left.
 - [4] Stop the engine.

Handling Instructions

Inspection of Safety Device

Repair the machine before operation whenever there is any abnormality.

1. Interlock system

Make sure that the interlock system operates correctly.
(Refer to "Interlock System")

2. ROPS

(If the machine is equipped with ROPS and a seat belt)

Make sure that the ROPS is not damaged or broken.

3. Seat belt

(If the machine is equipped with ROPS and a seat belt)

Make sure that the seat belt is not damaged or broken.

Inspection of Liquid Leakage

Important

After approximately 50 hours of operation, some tightened portions may be loosened and liquid such as oil may leak.
Be sure to retighten the parts.

Important

If liquid leakage found, repair it before operation.
Ignoring leakage will cause further trouble.

1. Check the bottom of the machine for leakage of liquid such as oil, water, etc.
2. Locate the leakage and identify the type of liquid.

Inspection of Bolts and Nuts

Important

The bolts and nuts may be loosened at the earlier stage of the use.
Be sure to retighten or replace before operating the machine whenever there is any abnormality.

1. Check the bolts and nuts for looseness and coming off.
2. Check the bolts and nuts for cracks and damages.
3. Check the bolts and nuts for rust.

4. Check around the bolts and nuts for traces of rust fluid.
5. Check for unequal bolt length.
6. Check the bolts and nuts for stripped threads and abrasion.

Mower Unit

Inspection of Reel Cutter (Cutting Cylinder) and Bed Knife (Bottom Blade)

Caution

Wear gloves when touching edged tools to avoid cutting your hands.

1. Check to see whether or not the edge of the reel cutter (cutting cylinder) and the bed knife (bottom blade) are too blunt to cut.
2. Make sure that the reel cutter (cutting cylinder) and the bed knife (bottom blade) are not cracked.
3. Check to see how much the reel cutter (cutting cylinder) and the bed knife (bottom blade) are worn.
4. Make sure that the reel cutter (cutting cylinder) and the bed knife (bottom blade) have not changed color due to heat from grinding.
5. Check to see whether or not the second edge face (relief) remains at the point of reel cutter (cutting cylinder).
6. Make sure that the welding between the reel cutter (cutting cylinder) and the disc has not come off.

Inspection of Rollers

1. Make sure that there is no abrasion nor adhesion of the roller.
2. Make sure that there is no wear of the roller shaft.
3. Make sure that there is no wear nor damage of the oil seal.
4. Make sure that there is no wear nor rust of the bearing.
5. Make sure that there is no play in the roller shaft.

Handling Instructions

Inspection of Covers

Warning

If you have removed the covers during inspection, be sure to securely install them in their original positions.
If a cover remains removed, the operator may come into contact with rotating parts or belts and foreign objects may fly off, possibly resulting in injuries.

1. Make sure that there is no wear or deterioration of the reel cover and all other covers.
2. Make sure that there is no damage to the reel cover and all other covers.
3. Make sure that there is no interference with moving parts due to deformation of the reel cover and all other covers.
4. Make sure that the reel cover and all other covers are installed in their appropriate positions.

Inspection of Mower Hook Metal Fitting

1. Make sure that the mower hook metal fitting moves when the clutch lever is gripped.
2. Make sure that the mower hook metal fitting is secured to the frame hook when the mower unit is raised.

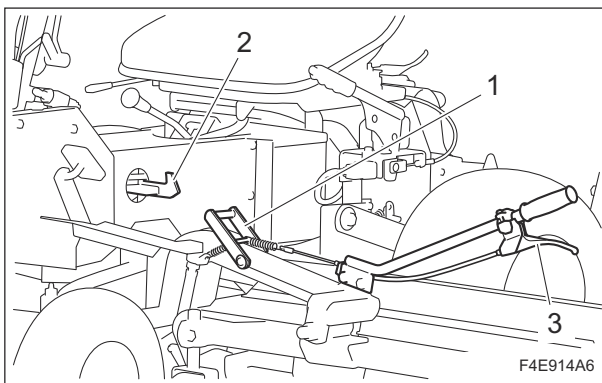

Inspection of Mower Hook Metal Fitting_001

1	Mower hook metal fitting
2	Frame hook
3	Clutch lever

Inspection of Bolts and Nuts

Important

The bolts and nuts may be loosened at the earlier stage of the use.
Be sure to retighten or replace before operating the machine whenever there is any abnormality.

1. Check the bolts and nuts for looseness and coming off.
2. Check the bolts and nuts for cracks and damages.
3. Check the bolts and nuts for rust.
4. Check around the bolts and nuts for traces of rust fluid.
5. Check for unequal bolt length.
6. Check the bolts and nuts for stripped threads and abrasion.

Adjustment before Work

Main Vehicle

Adjustment of Seat Position

Use the seat adjustment lever to adjust the seat back and forth.
Adjust the position according to the operator's body size.
The adjustment lever is located under the front side of the seat.

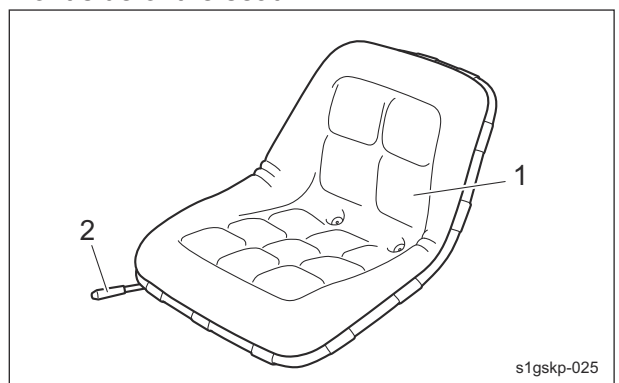

Adjustment of Seat Position_001

1	Seat
2	Adjustment lever

Handling Instructions

Mounting/Dismounting

Mounting/Dismounting Procedure

⚠ Caution

Do not step on the mower unit and tire when mounting/dismounting.

Place your foot on the step on the frame when mounting and dismounting the machine.

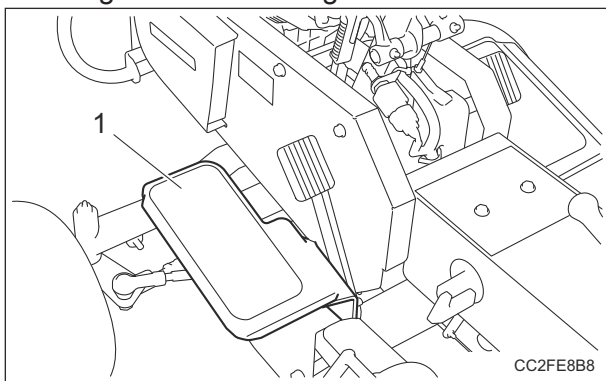

Mounting/Dismounting Procedure

1 Step

Start/Stop of Engine

Procedure to Start Engine

⚠ Caution

Before starting the engine, make sure that there are no other people or obstacles around the machine.

1. Set the fuel cock to the "Open" position.
2. Sit on the seat.
3. Make sure that the parking brake is applied.
4. Make sure that the traveling clutch lever is set to the "OFF" position.
5. Make sure that the reel rotation lever is set to the "Stop" position.
6. Make sure that the change lever is set to the neutral position.
7. Shift the throttle lever from the "Low speed" position halfway to the "High speed" position.
8. Pull the choke knob.
Pull the knob half way for restarting, as necessary.
9. Set the engine switch to the "ON" position.

10. Pull the starter grip swiftly, and the engine will start.

Important

Return the starter grip slowly to its original position after the engine starts.
Do not let go of the pulled starter grip since it may cause damage to the machine.

11. Make sure that the engine has started, and then slowly return the choke knob to its original position.
12. Shift the throttle lever to the "Low speed" position, and then warm up the engine for 1 to 2 minutes.

Procedure to Stop Engine

1. Set the reel rotation lever to the "Stop" position.
2. Shift the traveling clutch lever to the "OFF" position.
3. Depress the brake pedal.
4. Apply the parking brake.
5. Shift the change lever to the neutral position.
6. Shift the throttle lever to the "Low speed" position and continue idling for 1 to 2 minutes.
7. Set the engine switch to the "OFF" position.
8. Make sure that the engine has stopped.

Parking and Stopping

Leaving the machine

⚠ Caution

If the brakes are not sufficiently effective, use the wheel stoppers to secure the machine.

⚠ Caution

Never park the machine on a slope.

1. Park the machine on level ground.
2. Apply the parking brake.
3. Stop the engine.
4. Leave the driver's seat.
5. Set the fuel cock to the "Close" position.
6. Raise all the mower units.

Handling Instructions

Move

Traveling Operation

Danger

If the machine stops on a slope and the engine can not restart, keep the change lever set in the arbitrary position and use the foot brake to move to a flat place. Shifting the change lever to the "Neutral" position will result in the machine running out of control.

Caution

Under any circumstances drive the machine at such a speed that you can stop it immediately for emergencies.

Caution

Make sure not to touch rotating tires with your hands or legs.

1. Make sure that all the mower units are raised.
2. Start the engine.
(Refer to "Procedure to Start Engine")
3. Move the throttle lever toward the "High speed" side.
4. Shift the change lever in arbitrary position.
5. Depress the brake pedal, and release the parking brake.
6. Release the brake pedal.
7. Slowly tilt the traveling clutch lever back to set the "ON" position in the same way as half clutch.
8. The machine starts traveling.
9. Slowly tilt the traveling clutch lever forward to set to the "OFF" position.
10. The machine stops with the brake pedal depressed.

Cutting Work

Cutting Operation

Caution

Cutting work must be performed at an appropriate speed for the site and location. When cutting bumpy surfaces, keep the engine rpm steady, and slow down the cutting speed.

1. Lower all the mower units.
2. Start the engine.
"Procedure to Start Engine" (Page 5-8)
3. Move the throttle lever to the "High speed" position.
4. Shift the change lever in arbitrary position.
5. Slowly pull the reel rotation lever in the same way as clutch-slipping to rotate the reel cutters (cutting cylinders) of the left and right mower units.
6. Slowly pull the traveling clutch lever in the same way as clutch-slipping to move the machine forward while rotating the reel cutter (cutting cylinder) of the rear mower unit.
7. Shift the traveling clutch lever to the "ON" position, and then start the operation.

Transporting

Transporting Procedure

When loading the machine into a trailer or a truck to transport it, drive the machine in reverse. When unloading, drive the machine forward.

Cleaning After Use

The purpose of the machine cleaning is to:

- Prevent accidents
- Prevent damage to the machine
- Maintain machine performance

Properly clean the machine to maintain its functionality and performance.

If you detect any abnormalities with the machine, immediately perform maintenance or repairs.

Handling Instructions

Engine

Cleaning of Air Cleaner

A contaminated air cleaner element may cause malfunction of the engine. To maximize the life of the engine, clean the air cleaner properly.

1. Remove the air cleaner cover.
2. Remove the urethane element from the paper element.

Important

Do not use petroleum solvents to clean the paper element.

Important

If the air cleaner element is damaged or dirty, replace it.

3. Clean the urethane element with a solvent, such as a hardly flammable kerosene, and then soak it in the engine oil and wring out.
4. Remove dirt and dust from the paper element with blowing air or patting.
5. Install the urethane element into the paper element.
6. Install the air cleaner cover.

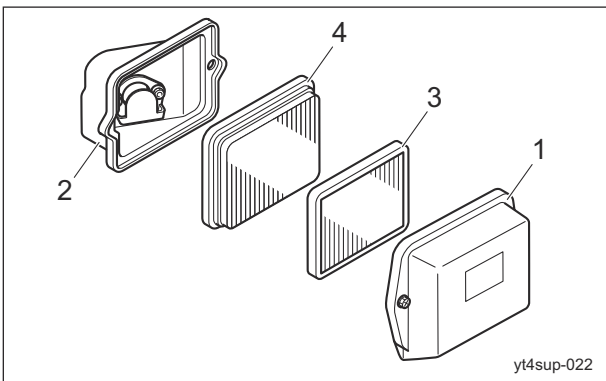

Cleaning of Air Cleaner_001

1	Air Cleaner Cover
2	Air cleaner case
3	Urethane element
4	Paper element

Cleaning Engine-Associated Parts

Caution

Perform operations after the engine and other parts have sufficiently cooled. Otherwise, you may suffer burns.

1. Clean clippings and remove dirt.
2. Blow compressed air to clean any grass or flammable materials that may be attached on or around the muffler.
3. Blow compressed air to clean any grass or flammable materials that may be attached on or around the cooling fins and recoil starter.

Mower Unit

Cleaning of Mower Unit

Important

While cleaning, do not allow water on the sealed parts of the reel shaft. (Avoid high-pressure water cleaning.) Otherwise, it may cause damage to the machine.

- Be sure to clean the mower unit after use.
1. Stop the engine.
 2. Carefully clean the front and back of the mower unit with water or compressed air.
 3. Remove any grass wrapped around the reel cutter (cutting cylinder).

Precautions for Maintenance	Page 6-2
Jacking Up The Machine	Page 6-2
About Jacking Up The Machine	Page 6-2
Jack-up Points	Page 6-2
Inspection and Cleaning	Page 6-4
Engine	Page 6-4
Main Vehicle	Page 6-4
Supplying Fluids	Page 6-6
Engine	Page 6-6
Main Vehicle	Page 6-6
Greasing	Page 6-7
About Greasing	Page 6-7
Greasing Points	Page 6-7
Lubrication	Page 6-9
About Lubrication	Page 6-9
Lubricating Points	Page 6-10
Adjustment	Page 6-10
Main Vehicle	Page 6-10
Mower Unit	Page 6-14
Replace	Page 6-18
Engine	Page 6-18
Main Vehicle	Page 6-19
Replacement of Tires	Page 6-19
Mower Unit	Page 6-20
Storage	Page 6-21
Long-Term Storage	Page 6-21

Maintenance

Precautions for Maintenance

Warning

The chapter "Maintenance" in this manual describes practical measures which should be performed by a mechanic with expertise. The owner should instruct the mechanic with expertise to perform maintenance service for this machine.

Caution

First, learn well the operations you plan to perform.

Important

Use tools appropriate for each operation.

Important

Use Baronsess genuine parts for replacement and accessories. Our product warranty may be void if you use non-genuine parts for replacement or accessories.

Jacking Up The Machine

About Jacking Up The Machine

Warning

When replacing a tire or beginning any other maintenance or repairs, be sure to chock the wheels to prevent the machine from moving. Before jacking up the machine, park it on a hard, flat surface such as a concrete floor and remove any obstacles that could prevent you from performing the work safely. When necessary, use an appropriate chain block, hoist, or jack. Support the machine securely with jack stands or appropriate blocks. Failure to do so may cause the machine to move or fall, resulting in injury or death.

Important

Only place a jack under the jack-up points specified. Placing a jack at any other point will result in damage to the frame or other parts.

Use the jack-up points identified in this manual when jacking up the machine.

Jack-up Points

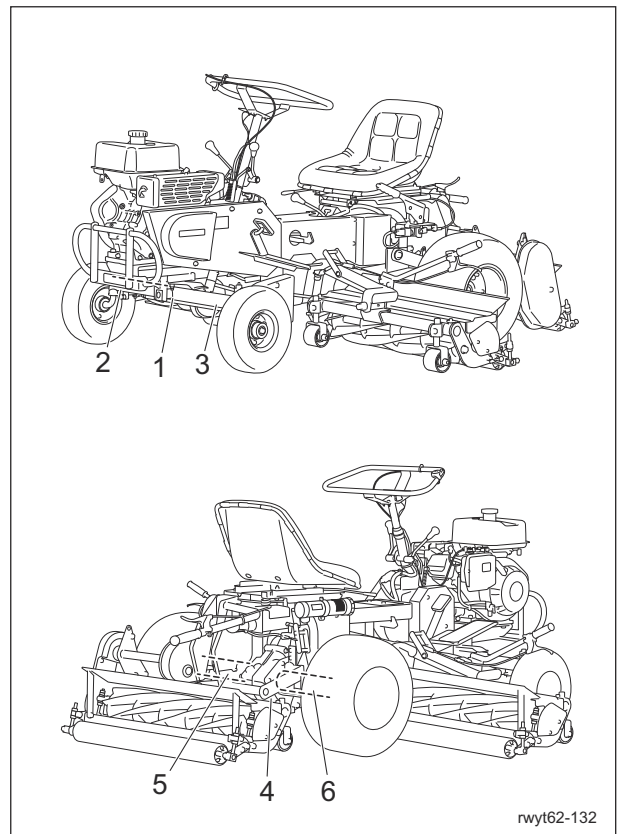

Jack-up Points_001

	Jack-up Points
1	Front axle, center
2	Front axle, right
3	Front axle, left
4	Transmission case, lower
5	Transmission axle case, left
6	Transmission axle case, right

1. Front axle, center

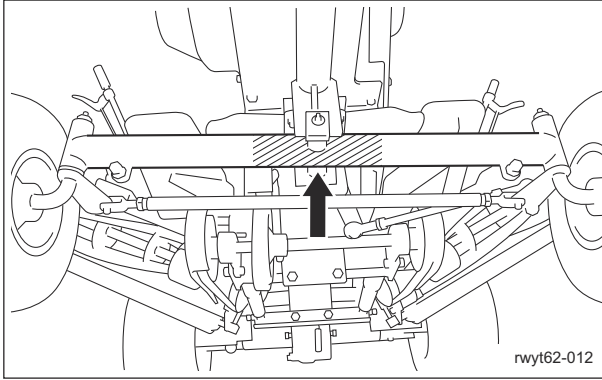

Jack-up Points_002

5. Transmission axle case, left

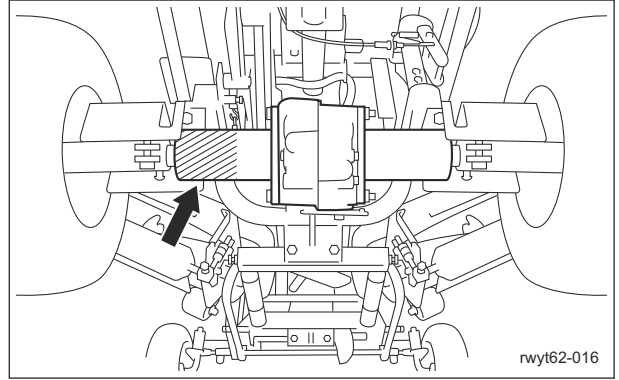

Jack-up Points_006

2. Front axle, right

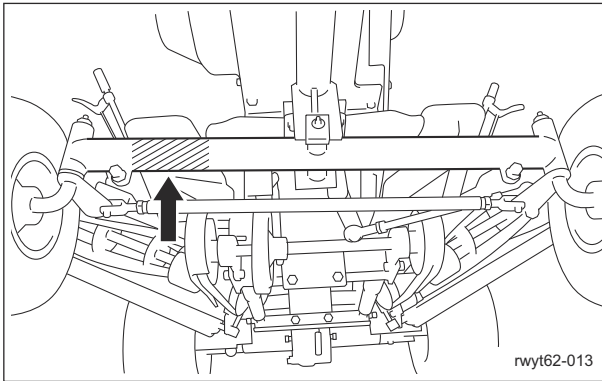

Jack-up Points_003

6. Transmission axle case, right

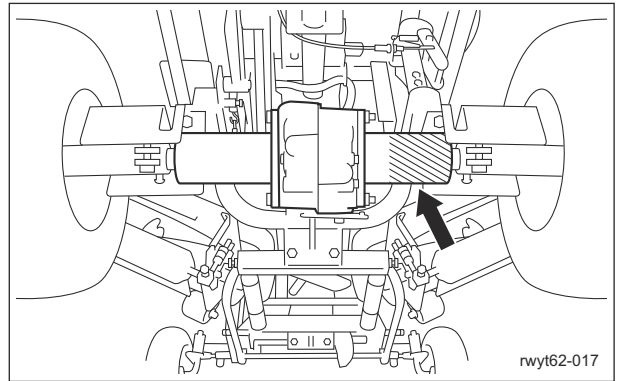

Jack-up Points_007

3. Front axle, left

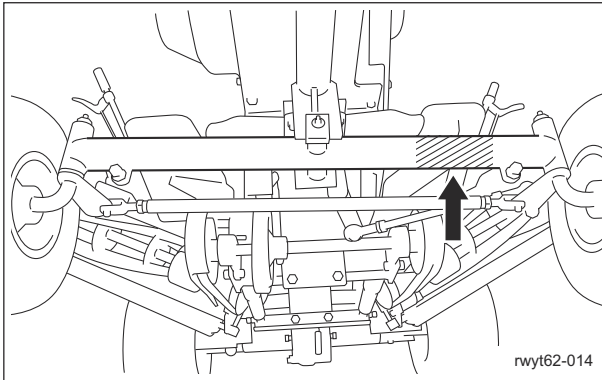

Jack-up Points_004

4. Transmission case, lower

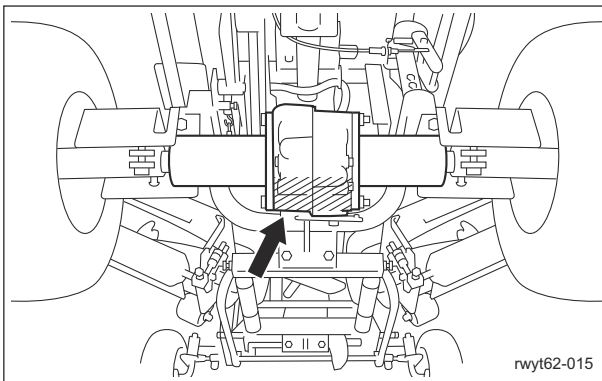

Jack-up Points_005

Maintenance

Inspection and Cleaning

Inspect and clean the machine with the goals of the followings.

- Accident prevention
- Failure prevention
- Performance retention

Make efforts for early detection of the machine failure and prevention of the sudden occurrence of trouble.

Perform maintenance and repair works immediately if any abnormality is found in the machine.

Engine

Cleaning of Fuel Strainer

If dust or dirt accumulates in the fuel strainer, the fuel flow will become insufficient. Periodically clean it.

Important

Clean the fuel strainer in a clean location, free of dust and dirt.

1. Close the fuel cock of the fuel strainer.
2. Remove the strainer cup from the fuel strainer.
3. Clean the filter and the inside of the strainer cup with a solvent, such as hardly flammable kerosene.
4. Dry with compressed air.

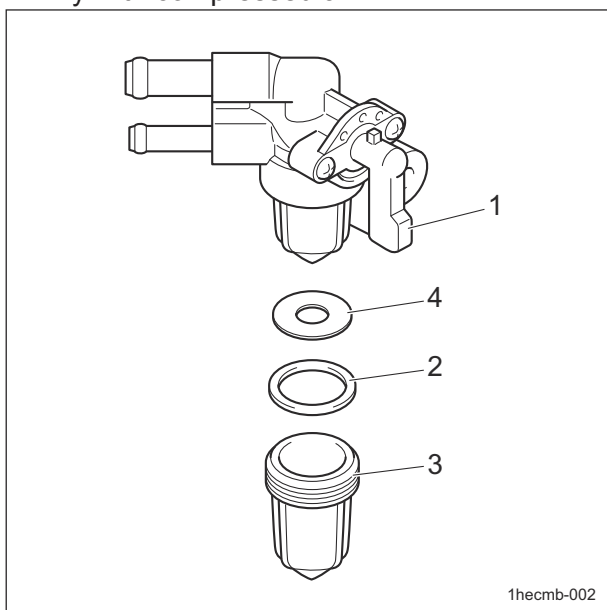

Cleaning of Fuel Strainer_001

1	Fuel cock
2	Packing
3	Strainer cup
4	Filter

Important

During installation, prevent contamination with dirt or dust.

If the fuel is contaminated with dirt, dust, etc., the fuel flow will become insufficient.

5. Correctly install all parts in their original positions.
6. Fill up the fuel tank with fuel, and then open the fuel cock.
7. Make sure that there is no fuel leakage.

Main Vehicle

Inspection of Belt

Warning

The engine must be stopped when the belt is inspected.

Warning

If you have removed the covers, etc., during inspection, be sure to securely install them in their original positions.

If covers, etc., remain removed, the operator may come in contact with rotating parts or belts, possibly resulting in injuries.

Important

A slacking or damaged belt may cause the cutter rotation speed or operation speed to be insufficient for operation.

Inspect belts. If necessary, adjust belt tension or replace.

1. Press the middle of the belt with your finger to check the belt tension.
2. Make sure that there are no cracks, damage or abnormal wear.

Inspection of Electrical Wiring

Important

Electrical short circuit will cause fire, electrical leakage and malfunction of electrical equipments.

1. Make sure that there is no defacement in wires and terminals.
2. Make sure that there is no deterioration or damage in wires and terminals.
3. Make sure that there is no looseness in wiring connections.
4. Make sure that there is no poor terminal connection.

Inspection of Wheel Mounting Bolt

Important

Tighten the wheel mounting bolts on the specified torque by using a torque wrench.

1. Check the wheel mounting bolts and wheel nuts for looseness and coming off.
2. Check the wheel mounting bolts and wheel nuts for cracks and damages.
3. Check the wheel mounting bolts and wheel nuts for rust.
4. Check around the wheel mounting bolts and wheel nuts for traces of rust fluid.
5. Check the wheel mounting bolts for unequal bolt length.
6. Check the wheel mounting bolts and wheel nuts for stripped threads and abrasion.

Inspection of Transmission Oil

1. Place the machine so that its frame will be level, and then make sure that the transmission oil level is at the oil level plug at any time.
The oil level plug is located on the right side of the transmission.

2. Check underneath the machine for oil leakage.

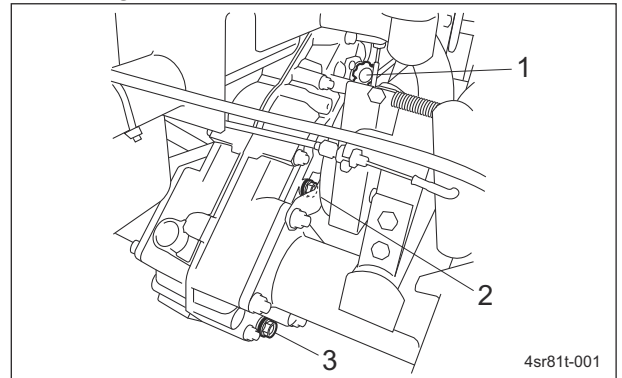

Inspection of Transmission Oil_001

1	Oil filling port
2	Oil level plug
3	Drain plug

Maintenance

Supplying Fluids

Engine

Supply of Engine Oil

Important
Do not supply too much engine oil. Otherwise, the engine may be damaged.

Important
Do not mix different types of engine oil.

Important
Be sure to use engine oil that is classified as API Service Grade SE or higher, with an SAE viscosity that is appropriate for the operating environment (ambient temperature).

Important
Securely tighten the oil level gauge.

1. Remove the oil level gauge.
2. Supply new engine oil from the oil filling port until it reaches the upper limit line on the oil level gauge.
3. Position the machine so that the engine is level, and then check the engine oil level without tightening the oil level gauge in the oil filling port.
4. Securely tighten the oil level gauge.

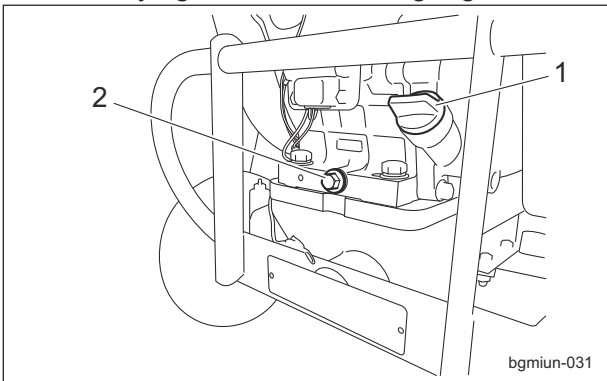

Supply of Engine Oil_001

1	Oil level gauge (oil filling port)
2	Drain plug

5. It will take a while for the supplied engine oil to descend into the oil pan. Check the oil level again 10 to 20 minutes after replenishment.

Main Vehicle

Filling of Transmission Oil

Important
Do not mix different types of transmission oil.

Important
Be sure to pour automobile gear oil that is classified as SAE Viscosity Grade #90 into the transmission.

1. Remove the oil filler cap.
2. Supply transmission oil through the oil filling port.

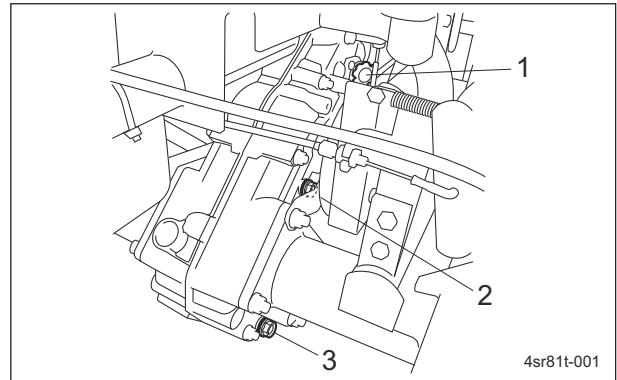

Filling of Transmission Oil_001

1	Oil filling port
2	Oil level plug
3	Drain plug

3. Check the oil level again 10 to 20 minutes after filling the oil.
4. Check underneath the machine for oil leakage.

Greasing

About Greasing

Since there may be adhesion or damage due to lack of grease on moving parts, they must be greased.

Add urea-based No. 2 grease in accordance with the Maintenance Schedule.

Other locations where the specified grease or lubricant is used are indicated in "Greasing Points".

Add grease using the specified grease or lubricant.

Greasing Points

Grease nipples are installed in the following locations.

Add grease every 50 hours of operation.

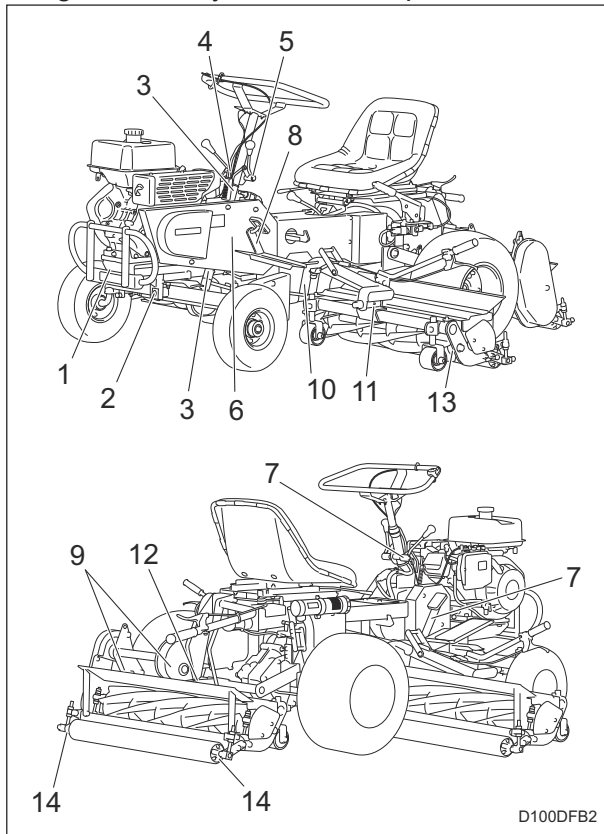

Greasing Points_001

	Location	No. of Greasing Points
1	Front wheel shaft	2
2	Front wheel front pin	1
3	Handle shaft	2
4	Reel rotation lever	1
5	Traveling clutch lever	1
6	Reel rotation tension lever	1
7	Brake pedal	1
8	Diff-lock pedal	1
9	Rear mower tension lever	2
10	Mower lifting arm	2
11	Mower frame	2
12	Rear mower oscillating metal part	1
13	Reel housing	6
14	Rear roller	6

1. Front wheel shaft
There is one point each on the left and the right wheels.

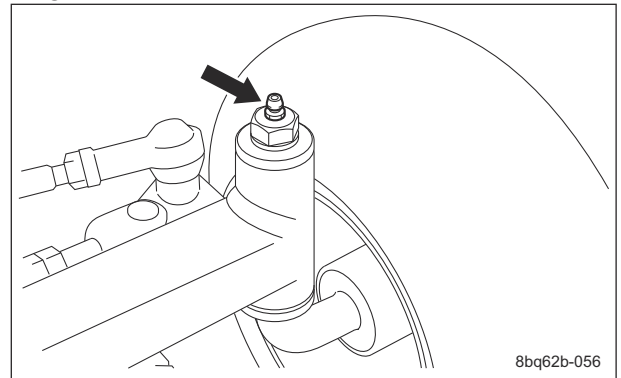

Greasing Points_002

2. Front wheel front pin

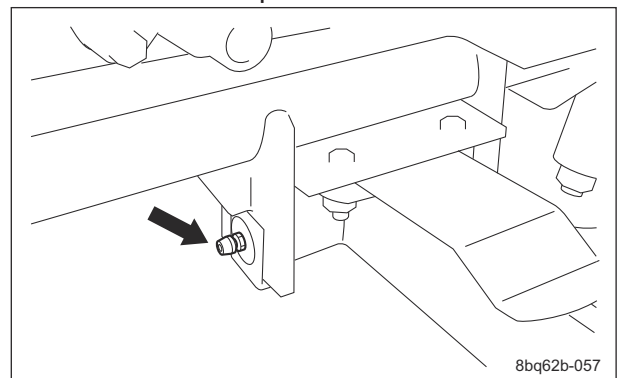

Greasing Points_003

Maintenance

3. Handle shaft

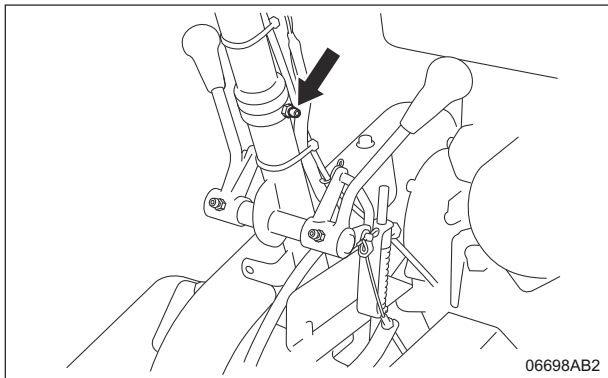

Greasing Points_004

6. Reel rotation tension lever

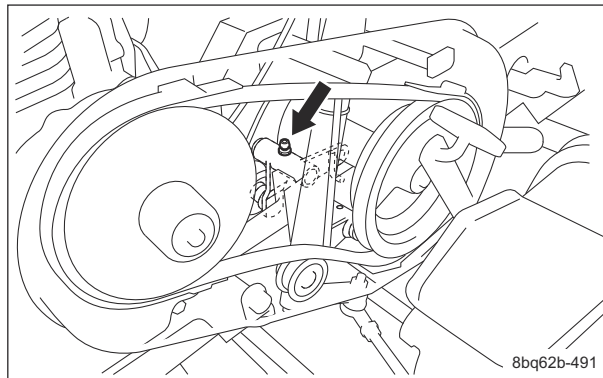

Greasing Points_008

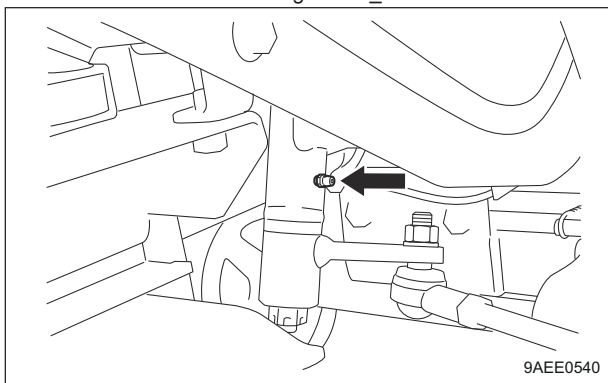

Greasing Points_005

7. Brake pedal

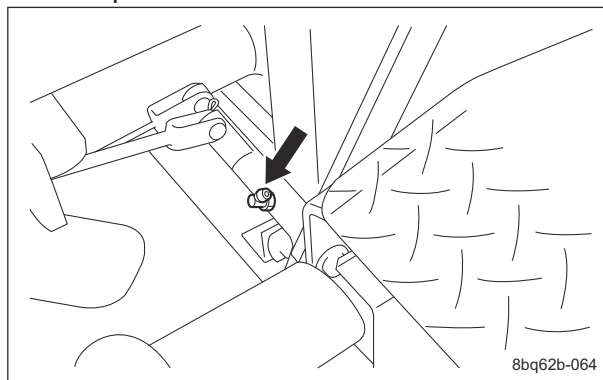

Greasing Points_009

4. Reel rotation lever

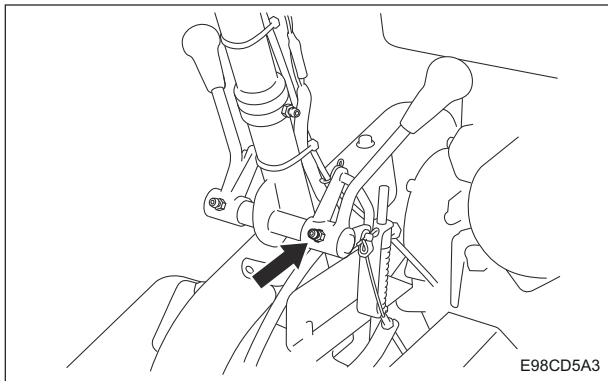

Greasing Points_006

8. Diff-lock pedal

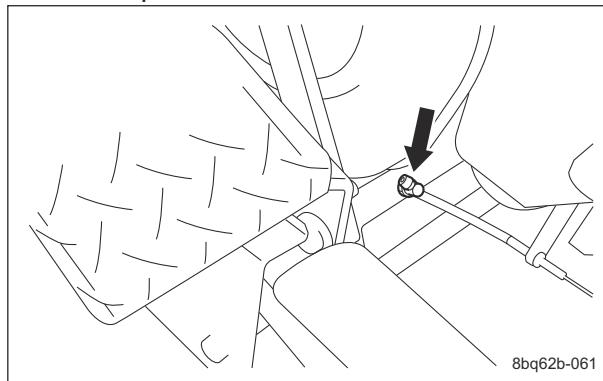

Greasing Points_010

5. Traveling clutch lever

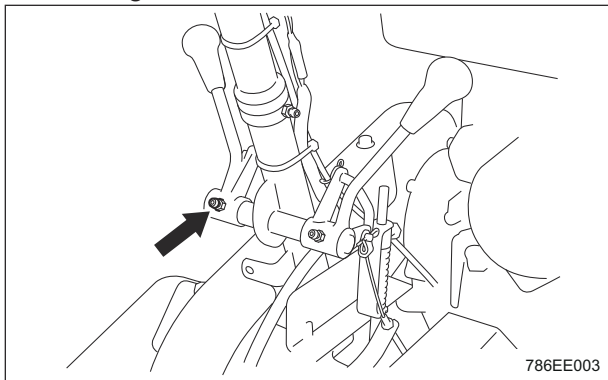

Greasing Points_007

9. Rear mower tension lever

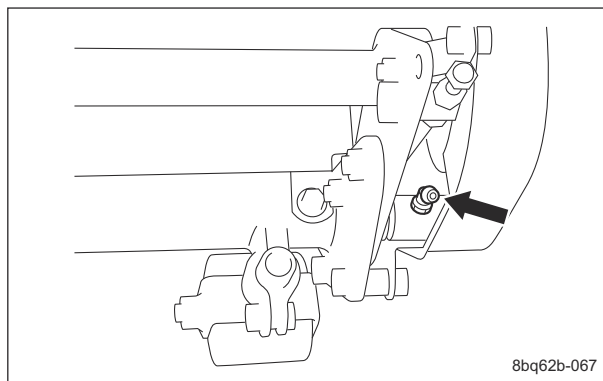

Greasing Points_011

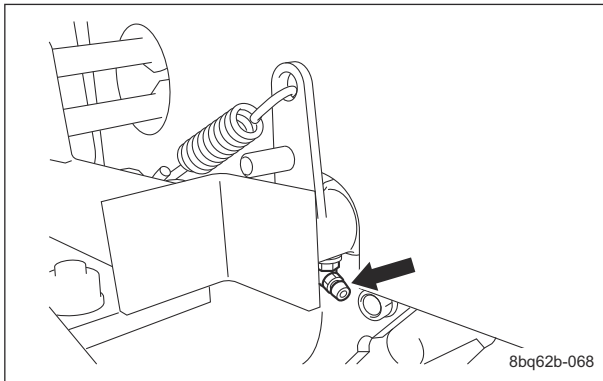

Greasing Points_012

10. Mower lifting arm

There is one point each on the left and the right mower units.

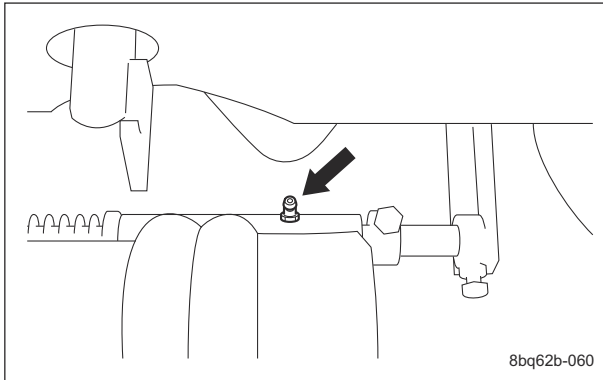

Greasing Points_013

11. Mower frame

There is one point each on the left and the right mower units.

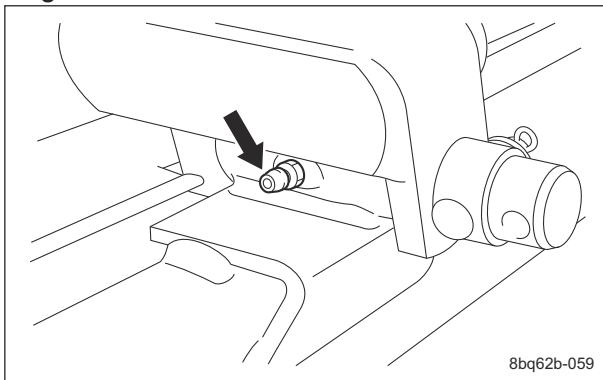

Greasing Points_014

12. Rear mower oscillating metal part

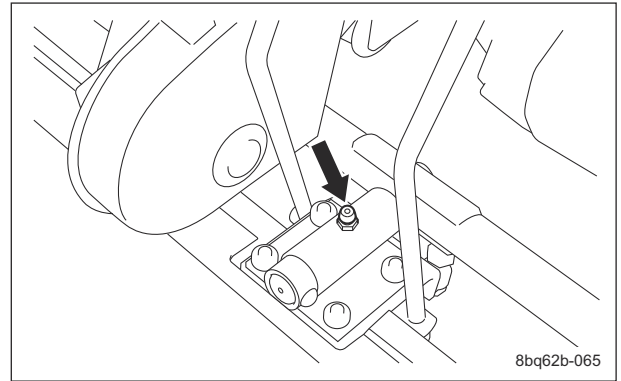

Greasing Points_015

13. Reel housing

There is one point each on the left and the right of each unit.

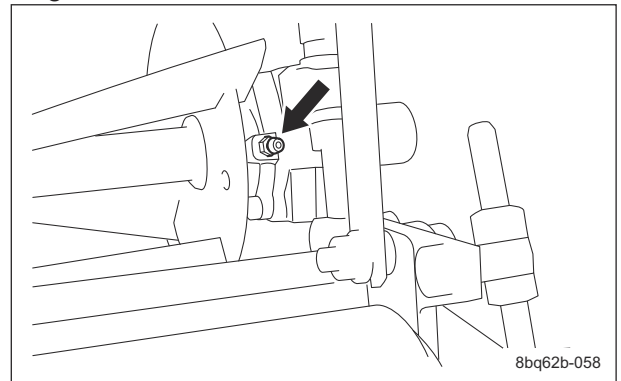

Greasing Points_016

14. Rear roller

There is one point each on the left and the right of each unit.

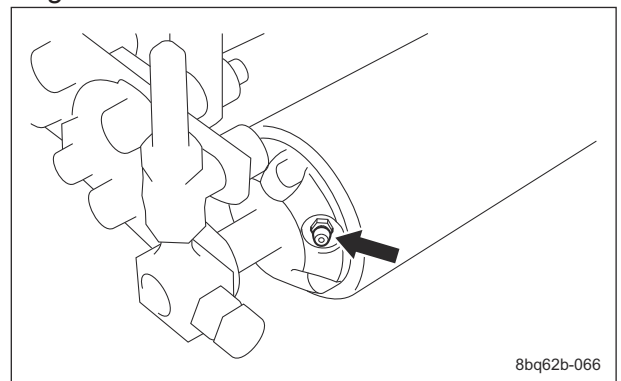

Greasing Points_017

Lubrication

About Lubrication

It is necessary to lubricate moving parts so that they will not become stuck or damaged. The locations where lubricant is used are indicated in "Lubricating Points". Apply the lubricant.

Maintenance

Lubricating Points

Apply lubricant at the following locations every 50 hours of operation.

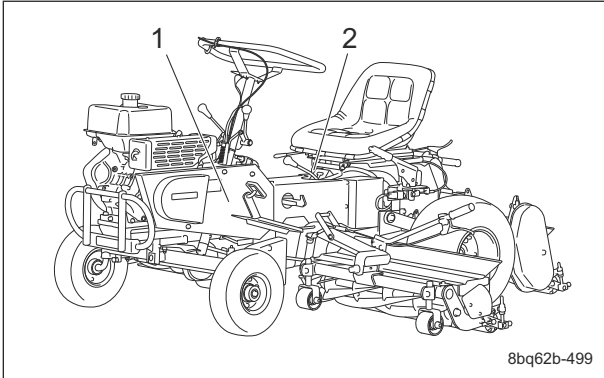

Lubricating Points_001

	Location	No. of lubricating points
1	Traveling tension lever	1
2	Brake intermediate lever	1

1. Traveling tension lever
There is one point.

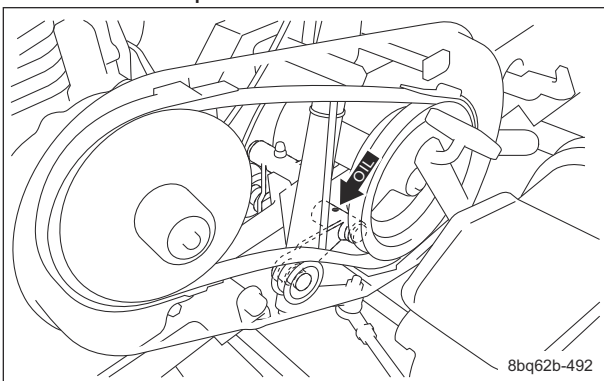

Lubricating Points_002

2. Brake intermediate lever
There is one point.

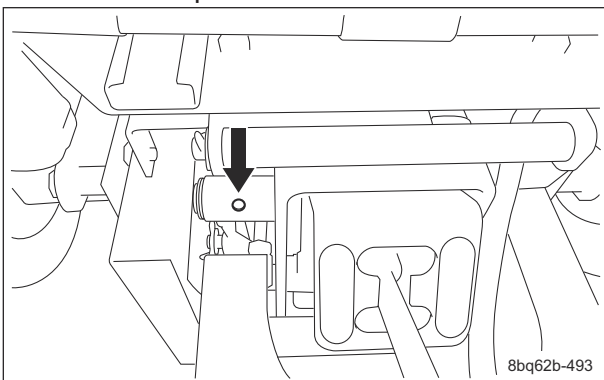

Lubricating Points_003

Adjustment

Main Vehicle

Adjustment of Belt Tension

Warning

Be sure to stop the engine before adjusting the belts.

Warning

If you have removed covers, etc., be sure to securely install them in their original positions. If covers, etc., remain removed, the operator may come in contact with rotating parts or belts, or foreign objects may fly off, possibly resulting in injuries.

Important

Check the belt tension after rotating the belt several times.

If the belt becomes slack due to frequent use, it may jump or slip. In addition, if it is overtightened, it may wear prematurely. If necessary, adjust it, and always check the belt for appropriate tension.

■ Belt Installation Locations

Belts are installed in this machine at the following locations.

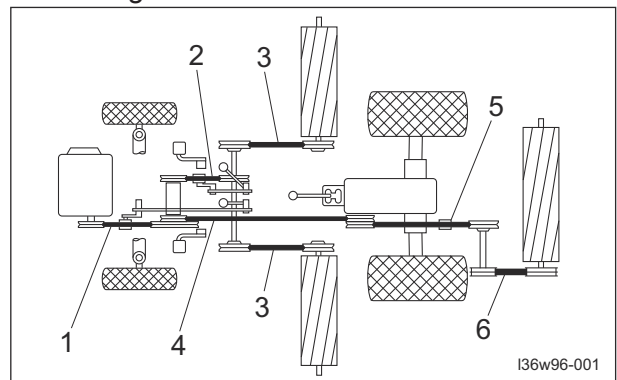

Belt Installation Locations_001

1	Traveling clutch
2	Reel rotation lever
3	Left and Right Mower Units
4	Transmission
5	Rear mower tension
6	Rear Mower Unit

Traveling Clutch

Adjust the tension of the belt installed on the traveling clutch section (Engine - Intermediate Shaft) by shortening or extending the adjustment rod.

1. Set the traveling clutch lever to the "ON" position.
2. Check the belt tension.

The belt tension is appropriate if the gap between the rod-tension metal fitting and the collar is 7 - 8 mm (0.28 - 0.31 in) with the belt tensioned.

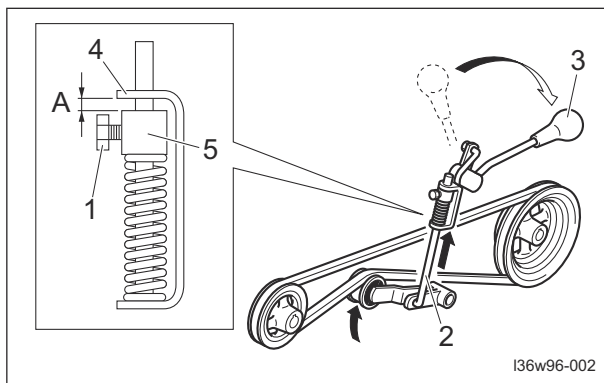

Traveling Clutch_001

1	Adjustment bolt
2	Rod
3	Traveling clutch lever
4	Rod-tension metal fitting
5	Collar
A	7 - 8 mm (0.28 - 0.31 in)

3. If the belt tension is inappropriate, follow the steps below to adjust it.

[1] Loosen the adjustment bolt.

[2] Adjust the gap between the rod-tension metal fitting and the collar.

[3] Tighten the adjustment bolt to fix the collar securely.

Reel Rotation Lever

Adjust the tension of the belt installed on the transmission section (Intermediate shaft - Transmission) by shortening or extending the adjustment rod.

1. Set the reel rotation lever to the "Rotation" position.
2. Check the belt tension.

The belt tension is appropriate if the gap between the rod-tension metal fitting and the collar is 7 - 8 mm (0.28 - 0.31 in) with the belt tensioned.

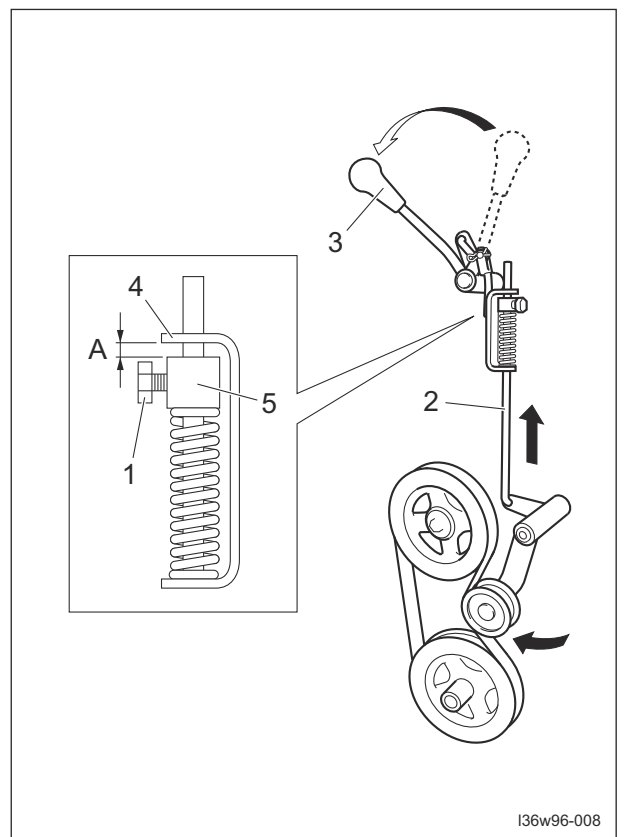

Reel Rotation Lever_001

1	Adjustment bolt
2	Rod
3	Reel rotation lever
4	Rod-tension metal fitting
5	Collar
A	7 - 8 mm (0.28 - 0.31 in)

3. If the belt tension is inappropriate, follow the steps below to adjust it.

[1] Loosen the adjustment bolt.

[2] Adjust the gap between the rod-tension metal fitting and the collar.

[3] Tighten the adjustment bolt to fix the collar securely.

Maintenance

■Left and Right Mower Units

The tension of the belt installed on the left and right mower units section (Under intermediate shaft – Mower units) is always stretched at a constant tension by the springs.

1. Check the belt tension.

The belt tension is appropriate if the gap between the collar and the mower lifting arm is 1 mm (0.04 in).

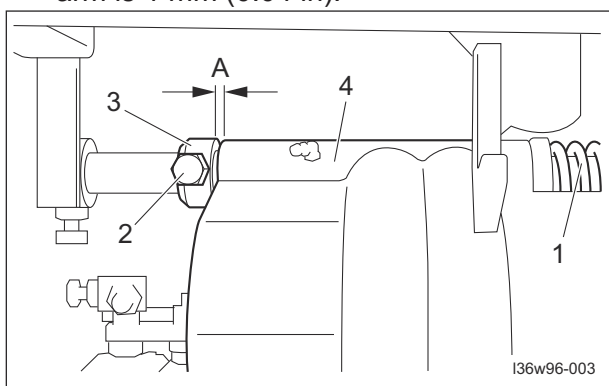

Left and Right Mower Units_001

1	Spring
2	Adjustment bolt
3	Collar
4	Mower lifting arm
A	1 mm (0.04 in)

2. If the belt tension is inappropriate, follow the steps below to adjust it.

- [1] Loosen the adjustment bolt.
- [2] Adjust the gap between the collar and the mower lifting arm.
- [3] Tighten the adjustment bolt to fix the collar securely.
- [4] Follow the same steps to adjust the belts of the mower units section on the opposite side.

■Transmission

The tension of the belt installed on the transmission section (Intermediate shaft – Transmission) is always stretched at a constant tension by the springs.

1. Check the belt tension.

The belt tension is appropriate when the belt slacks by approximately 10 mm (0.39 in) when you apply a force of 98 N (10 kgf) with your finger to the belt at the middle point.

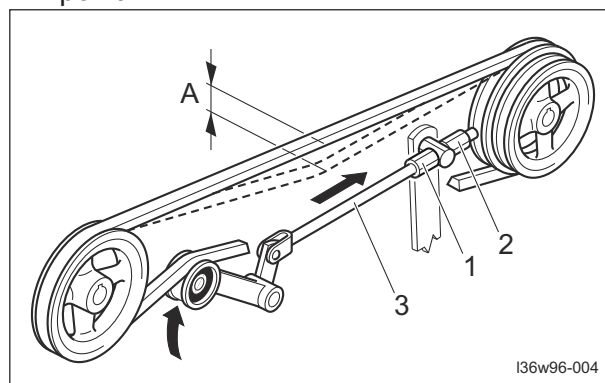

Transmission_001

1	Adjustment nut A
2	Adjustment nut B
3	Rod
A	10 mm (0.39 in)

2. If the belt tension is inappropriate, follow the steps below to adjust it.

- [1] Loosen the adjustment nut A.
- [2] Tighten the adjustment nut B so that the belt tension is as specified, and then adjust the length of the rod.
- [3] Tighten the adjustment nut A and make sure that the rod is fixed securely.

■Rear Mower Tension

Adjust the tension of the belt installed on the rear mower tension section (Transmission – Rear mower shaft) by shortening or extending the adjustment rod.

1. Lower the rear mower unit on a level surface.
2. Check the belt tension.
The belt tension is appropriate if the gap in the spring is approximately 1 mm (0.04 in).

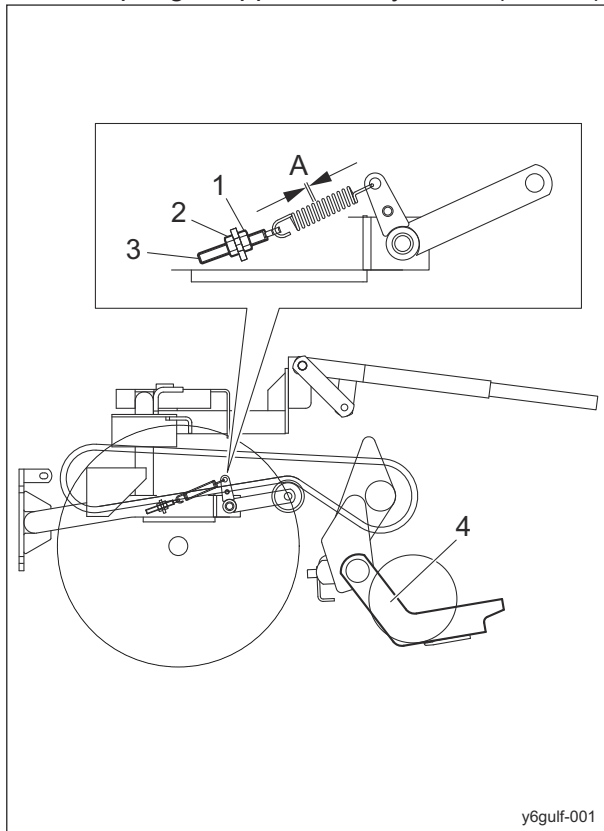

Rear Mower Tension_001

1	Adjustment nut A
2	Adjustment nut B
3	Rod
4	Rear mower unit
A	1 mm (0.04 in)

3. If the belt tension is inappropriate, follow the steps below to adjust it.
 - [1] Loosen the adjustment nut A.
 - [2] Tighten the adjustment nut B to adjust the gap in the spring.
 - [3] Tighten the adjustment nut A and make sure that the rod is fixed securely.
 - [4] Raise the rear mower unit.

- [5] Make sure that the reel cutter (cutting cylinder) does not rotate when the machine travels.

■Rear Mower Unit

Adjust tension of the belt installed on the rear mower unit section (Under intermediate shaft – Rear mower unit) by shortening or extending the adjustment rod.

1. Check the belt tension.
The belt tension is appropriate when the belt slacks by approximately 10 mm (0.39 in) when you apply a force of 98 N (10 kgf) with your finger to the belt at the middle point.

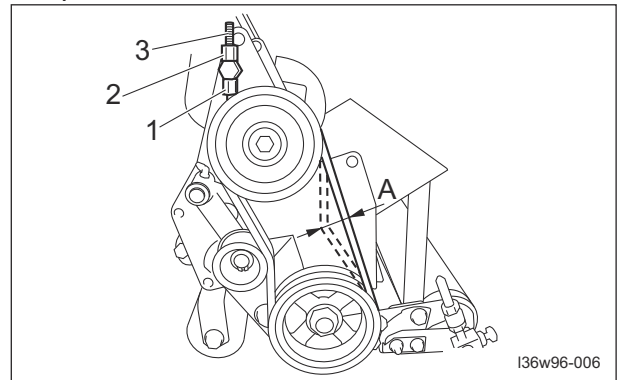

Rear Mower Unit_001

1	Adjustment nut A
2	Adjustment nut B
3	Rod
A	10 mm (0.39 in)

2. If the belt tension is inappropriate, follow the steps below to adjust it.
 - [1] Loosen the adjustment nut A.
 - [2] Tighten the adjustment nut B so that the belt tension is as specified, and then adjust the length of the rod.
 - [3] Tighten the adjustment nut A and make sure that the rod is fixed securely.

Maintenance

Mower Unit

Adjustment of Blade Engagement

Warning

Make sure that the parking brake is firmly applied before performing the operation.

Caution

Be sure to perform this operation on your own.

Caution

When handling the reel cutter (cutting cylinder) or bed knife (bottom blade), wear gloves to protect your hands. Pay attention not to let the reel cutter (cutting cylinder) catch your gloves. Otherwise, you may injure your hand or fingers.

1. Stop the engine.
2. Raise all the mower units.
3. Remove the belts in the right, left and rear mower units.
4. With the nuts A and B, adjust the engagement between the reel cutter (cutting cylinder) and the bed knife (bottom blade) so that Takumi Paper (Baroness genuine paper strips) or two to three strips of newspaper will be cut by the edge of both blades when the blades in their entirety come slightly into contact with each other.
5. Insert Takumi Paper or two to three strips of newspaper into the space between the reel cutter (cutting cylinder) and the bed knife (bottom blade) at an angle of 90 degrees. Then, rotate the reel cutter (cutting cylinder) counter-clockwise (when you face the mower unit from the left) by hand to check the sharpness of the blades.
Check the sharpness of the entire range (three or four points) of the reel cutter (cutting cylinder).
 - If a gap is created between edges:
 - [1] Loosen the lock nut and slightly loosen nut B.
 - [2] Contact the reel cutter (cutting cylinder) and bed knife (bottom blade) slightly, then tighten nut A.

- If the reel cutter (cutting cylinder) is too tight to turn:
 - [1] Loosen the lock nut and slightly loosen nut A.
 - [2] Reduce the contact pressure between the reel cutter (cutting cylinder) and bed knife (bottom blade), then tighten nut B.
- If the blades still cannot cut well:
Perform back lapping of the reel cutter (cutting cylinder).

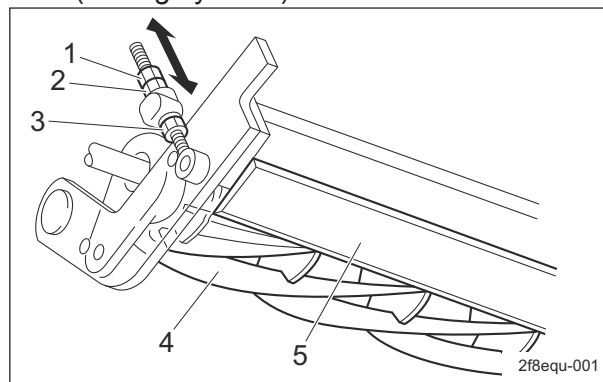

Adjustment of Blade Engagement_001

1	Lock nut
2	Nut A
3	Nut B
4	Reel cutter (Cutting cylinder)
5	Bed knife (Bottom blade)

6. Install the belts for left and right mower units and for rear mower unit.

Adjustment of Cutting Height

Important

The front wheel is provided to prevent the reel cutter (cutting cylinder) from damaging a convex portion of the lawn surface. Adjust the height so that the front wheel will not be grounded but raised by 10 - 20 mm (0.39 - 0.79 in) off the ground.

The cutting height is adjusted by moving the roller up or down. Refer to the cutting height scale plate to decide the height.

1. To increase cutting height:
Loosen nut A, lower the roller, then tighten nut B.

2. To decrease cutting height:
Loosen nut B, raise the roller, then tighten nut A.

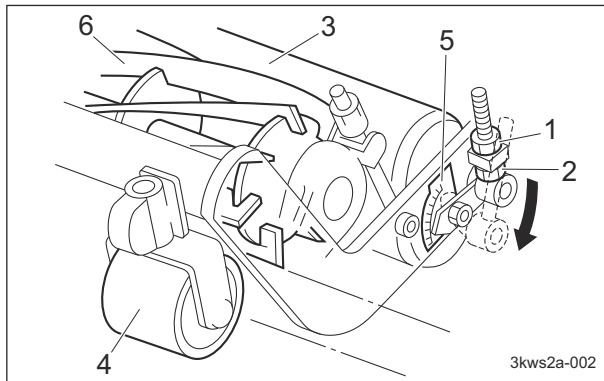

Adjustment of Cutting Height_001

1	Nut A
2	Nut B
3	Roller
4	Front wheel
5	Cutting height scale plate
6	Reel cutter (cutting cylinder)

Back Lapping

Back lapping is work similar to sharpening a cooking knife. If the edges of the reel cutter (cutting cylinder) and the bed knife (bottom blade) become blunt and make cutting difficult, both the reel cutter (cutting cylinder) and the bed knife (bottom blade) should be simultaneously sharpened by reversing the reel cutter (cutting cylinder) with an abrasive paste applied.

However, back lapping is a temporary measure and would not restore the sharpness completely.

If the edges of the reel cutter (cutting cylinder) and the bed knife (bottom blade) become blunt and difficult to cut, follow the steps below to perform back lapping.

Warning

During back lapping, the reel cutter (cutting cylinder) rotates. Keep hands and feet away from moving parts.

Caution

Do not perform back lapping with any other persons.

1. Have the following items ready: Back lapping machine, Takumi Paper (Baroness genuine paper strips) or two to three strips of newspaper, Abrasive [Back lapping powder mixed with oil; or gel compound (Baroness genuine abrasive)], Brush, Socket (opposite side 27).

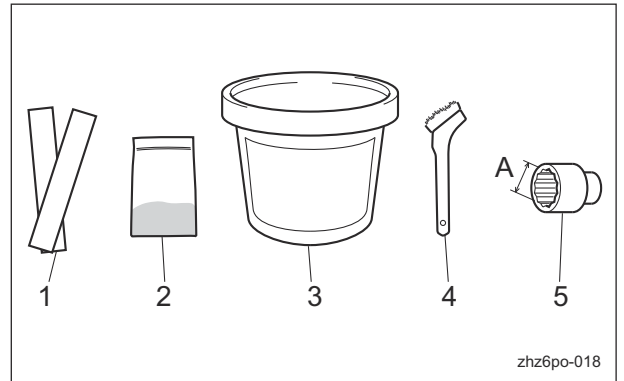

Back Lapping_001

1	Takumi Paper or newspaper
2	Back lapping powder
3	Gel compound
4	Brush
5	Socket (opposite side 27)
A	27 mm (1.06 in)

Note:

Mixing ratio for abrasive in volume is one part back lapping powder (#150 - #200) to three or four parts oil.

Caution

When handling the reel cutter (cutting cylinder) or bed knife (bottom blade), wear gloves to protect your hands. Pay attention not to let the reel cutter (cutting cylinder) catch your gloves, etc. Otherwise, you may injure your hand or fingers.

Important

After cutting grass, adjust the engagement of the blades, before checking the sharpness of the blade.

2. Stop the engine.
3. Apply the parking brake.
4. Raise the mower unit that requires back lapping.
5. Remove the belt for the mower unit that requires back lapping.

Maintenance

6. Insert Takumi Paper or two to three strips of newspaper into the space between the reel cutter (cutting cylinder) and the bed knife (bottom blade) at an angle of 90 degrees, then rotate the reel cutter (cutting cylinder) counter-clockwise (when you face the mower unit from the left) by hand to check the sharpness.
7. Check the sharpness at entire range (three or four points from left edge to right one) of the reel cutter (cutting cylinder).
8. Using a piece of chalk, mark locations on the blade that are sharp.
9. Lower the mower unit that requires back lapping to the ground.
10. Connect the lapping machine and the shaft of reel cutter (cutting cylinder) with the socket (opposite side 27).
11. Turn on the switch of the lapping machine to rotate the reel cutter (cutting cylinder) in the direction opposite to the cutting direction.
12. Apply the abrasive evenly with the brush on the top side of reel cutter (cutting cylinder) where the newspaper was cut well or of chalk-marked locations. (Never apply to blunt areas.)
13. Idle the machine for a while, and then switch off the lapping machine to stop rotation of the reel cutter (cutting cylinder) when contact noise is no longer heard.
14. Raise the mower unit that requires back lapping.
15. Wash off or wipe off with cloth etc. the abrasive from the reel cutter (cutting cylinder), then check it for sharpness.
16. Repeat steps 6 to 15 until the entire range (three or four points) of the reel cutter (cutting cylinder) will be uniformly sharpened.
17. Lower the mower unit that requires back lapping to the ground.
18. Finally, apply the abrasive on the entire blade width of the reel cutter (cutting cylinder) and perform final back lapping.
19. Stop the rotation of the reel cutter (cutting cylinder), and then carefully and thoroughly wash off any remaining abrasive.
20. While checking the blade for sharpness, adjust blade engagement.
21. Raise the mower unit.

22. Install the belt for the mower unit.

Sharpening of Reel Cutter (Cutting Cylinder)

The sharpening of the reel cutter (cutting cylinder) consists in maintaining its roundness and creating a relief (second edge face). This work should be performed if the sharpness cannot be restored, even after back lapping, or if the relief (second edge face) has worn away.

Sharpen the reel cutter (cutting cylinder) when the sharpness cannot be restored, even after back lapping, or when the relief (second edge face) has worn away, there is full contact or back lapping takes too much time.

In addition, if the reel cutter (cutting cylinder) becomes worn and its shape conical, perform cylindrical grinding to return it to a cylindrical shape.

For sharpening the reel cutter (cutting cylinder), contact your dealer or Baroness unless you have a grinding machine.

Caution

Both the reel cutter (cutting cylinder) and the bed knife (bottom blade) are edged tools. Handle them carefully, since they could cut your hands and feet.

Caution

Wear gloves when touching edged tools to avoid cutting your hands.

The criteria for sharpening the reel cutter (cutting cylinder) are described below. However, these criteria are only a reference and do not guarantee performance of a reel cutter (cutting cylinder).

1. If the outer diameter of the reel cutter (cutting cylinder) after sharpening is more than the usage limit, the reel cutter (cutting cylinder) can be sharpened.

New		Usage limit	
Dimension A (Outer diameter of reel cutter (cutting cylinder))	Dimension B (Distance from blade edge to outer edge of reel cutter (cutting cylinder) shaft)	Dimension A (Outer diameter of reel cutter (cutting cylinder))	Dimension B (Distance from blade edge to outer edge of reel cutter (cutting cylinder) shaft)
163 mm (6.42 in)	68.8 mm (2.71 in)	143 mm (5.63 in)	58.8 mm (2.31 in)

Note:
The outer diameter of the reel cutter (cutting cylinder) shaft is 25.4 mm (1.00 in).

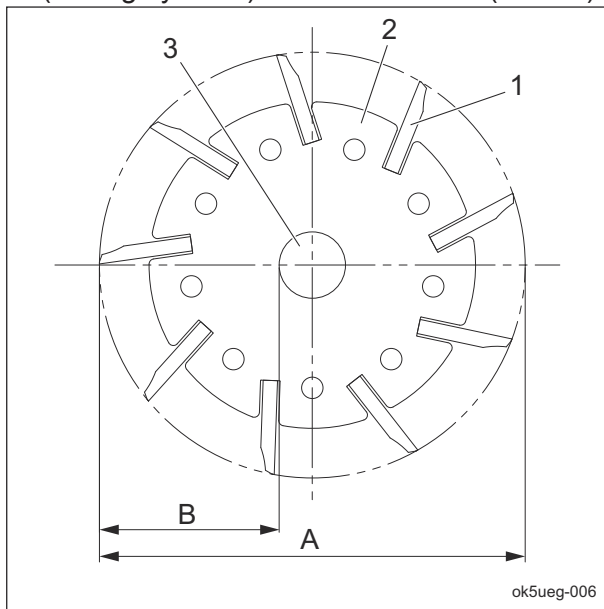

Sharpening of Reel Cutter (Cutting Cylinder)_001

1	Reel cutter (cutting cylinder) blade
2	Reel cutter (cutting cylinder) disc
3	Reel cutter (cutting cylinder) shaft
A	Outer diameter of reel cutter (cutting cylinder)
B	Distance from blade edge to outer edge of reel cutter (cutting cylinder) shaft

2. Sharpening is necessary when the reel cutter (cutting cylinder) reaches a condition described below.

[1] When the sharpening width (length of contacting surface of bed knife (bottom blade)) for the outer diameter of the reel cutter (cutting cylinder) is greater than the usage limit.

Outer diameter of reel cutter (cutting cylinder) (new part)	Usage limit of sharpening width for outer diameter of reel cutter (cutting cylinder)
163 mm (6.42 in)	3.0 mm (0.12 in) (factory-recommended)

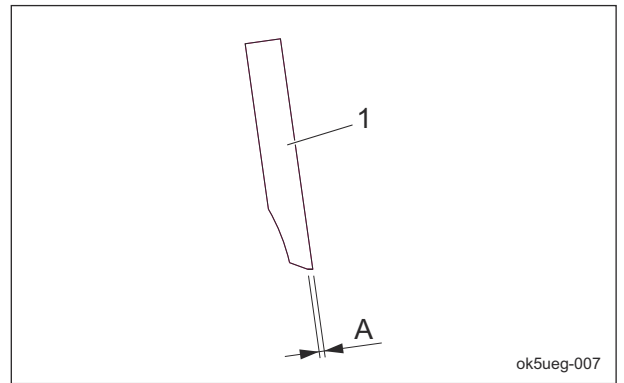

Sharpening of Reel Cutter (Cutting Cylinder)_002

1	Reel cutter (cutting cylinder) blade
A	Sharpening width for outer diameter of reel cutter (cutting cylinder)

[2] When the edges become blunt or the blade edge cannot be formed with back lapping

[3] When the reel cutter (cutting cylinder) becomes worn and its shape conical, or when blade engagement adjustment cannot be performed

Maintenance

Replace

Engine

Change of Engine Oil

Caution

Be careful with hot oil, which could cause burns if it contacts your skin.

Important

When changing the engine oil, be sure to drain it into a container and discard it in accordance with local laws and regulations.

Important

Be sure to use engine oil that is classified as API Service Grade SE or higher, with an SAE viscosity that is appropriate for the operating environment (ambient temperature).

Important

Securely tighten the oil level gauge.

Change the engine oil more frequently if it is contaminated and especially if you use the machine in dusty areas or operate the engine at high loads or in high temperatures.

1. Move the machine onto a level surface, and then stop the engine.
2. Install the drain gutter (accessory).
3. Remove the drain plug while the engine oil is warm, and then drain the oil into a container.

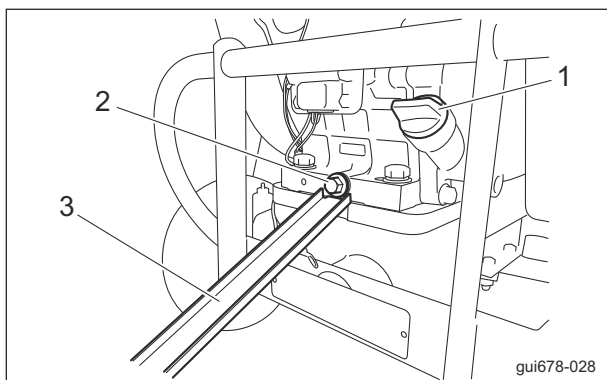

Change of Engine Oil_001

1	Oil level gauge (oil filling port)
2	Drain plug
3	Drain gutter

4. Install the drain plug on the engine.
5. Remove the oil level gauge.
6. Supply new engine oil through the oil filling port.
The engine oil quantity is 1.0 dm³ (1.0 L).
7. Position the machine so that the engine is level, and then check the engine oil level without tightening the oil level gauge in the oil filling port.
8. After checking the oil level with the oil level gauge, add more engine oil if it is insufficient.
9. Securely tighten the oil level gauge.
10. It will take a while for the supplied engine oil to descend into the oil pan.
Check the oil level again 10 to 20 minutes after replenishment.
11. Check underneath the machine for oil leakage.

Replacement of Air Cleaner Element

Important

A contaminated air cleaner element may cause malfunction of the engine.

1. The timing for replacing the air cleaner element is described below.
 - [1] Replace the air cleaner element in accordance with the Maintenance Schedule.
 - [2] If it is significantly contaminated, replace it, even if the hours of operation do not exceed the specified time.
2. Replace the air cleaner element by following the same steps as for cleaning the air cleaner.
"Cleaning of Air Cleaner" (Page 5-10)

Main Vehicle

Change of Transmission Oil

⚠ Caution

Be careful with hot oil, which could cause burns if it contacts your skin.

Important

When you change the transmission oil, be sure to drain it into a bowl and discard it in accordance with regional laws and regulations.

Important

Be sure to pour automobile gear oil that is classified as SAE Viscosity Grade #90 into the transmission.

Change the entire transmission oil according to the maintenance schedule.

1. Move the machine onto a level surface and stop the engine.
2. Remove the drain plug while the transmission oil is warm, and then drain the oil into a bowl.
3. Attach the drain plug to the transmission.
4. Remove the oil filling port cap and oil level plug.
5. Pour new transmission oil through the oil filling port.
The transmission oil quantity is 2.0 dm³ (2.0 liters).
6. Make sure that the transmission oil level is filled up to the tip of the oil level opening.
7. Attach the oil filling port cap and oil level plug.

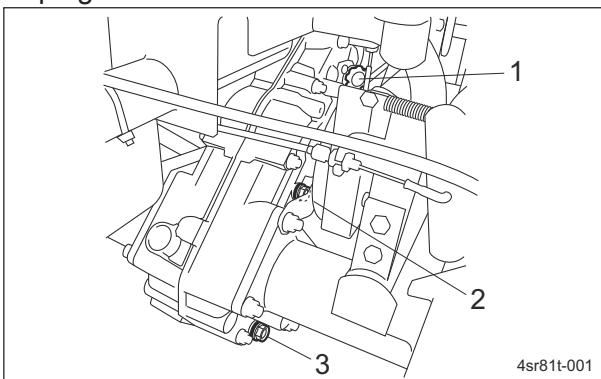

Change of Transmission Oil_001

1	Oil filling port
2	Oil level plug
3	Drain plug

8. Check underneath the machine for oil leakage.

Replacement of Tires

Replacement of Front Tires

1. Removing front tires

Follow the steps below to remove the front tires:

- [1] Loosen the bolts.

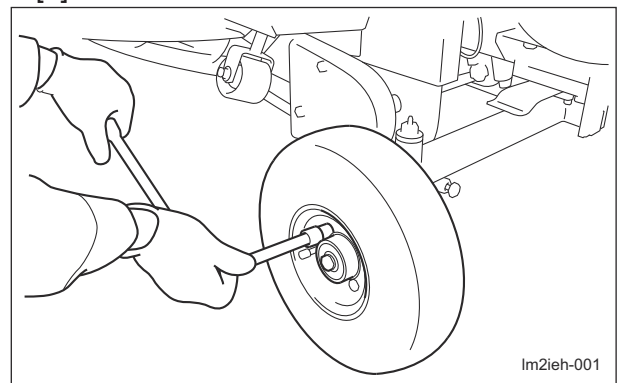

Replacement of Front Tires_001

- [2] Place the tire jack beneath the jack-up point of the front axle area securely, then raise it until the tire lifts off the ground.
"Jack-up Points" (Page 6-2)
- [3] Remove the bolts.
- [4] Remove the tire from the wheel mounting base.

2. Installing front tires

Important

Tighten the bolts in the tightening order (diagonally).

Important

Tighten the wheel mounting bolts on the specified torque by using a torque wrench.

For installing the front tires, reverse the removing procedure.

Maintenance

Replacement of Rear Tires

1. Removing rear tires

Follow the steps below to remove the rear tires:

[1] Loosen the bolts.

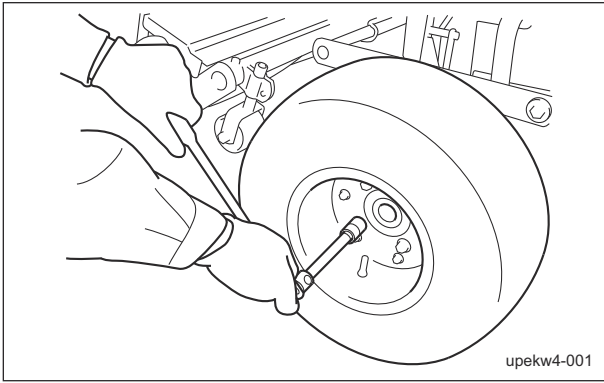

Replacement of Rear Tires_001

[2] Place the tire jack beneath the jack-up point of the rear wheel transmission area securely, then raise it until the tire lifts off the ground.

"Jack-up Points" (Page 6-2)

[3] Remove the bolts.

[4] Remove the tire from the wheel mounting base.

2. Installing rear tires

Important

Tighten the bolts in the tightening order (diagonally).

Important

Tighten the wheel mounting bolts on the specified torque by using a torque wrench.

For installing the rear tires, reverse the removing procedure.

Mower Unit

Replacement of Reel Cutter (Cutting Cylinder)

Caution

Both the reel cutter (cutting cylinder) and the bed knife (bottom blade) are edged tools. Handle them carefully, since they could cut your hands and feet.

Caution

Wear gloves when touching edged tools to avoid cutting your hands.

The criteria for replacing the reel cutter (cutting cylinder) are described below. However, these criteria are only a reference and do not guarantee performance like that of a new reel cutter (cutting cylinder).

1. When the outer diameter of the reel cutter (cutting cylinder) is less than the usage limit

New		Usage limit	
Dimension A (Outer diameter of reel cutter (cutting cylinder))	Dimension B (Distance from blade edge to outer edge of reel cutter (cutting cylinder) shaft)	Dimension A (Outer diameter of reel cutter (cutting cylinder))	Dimension B (Distance from blade edge to outer edge of reel cutter (cutting cylinder) shaft)
163 mm (6.42 in)	68.8 mm (2.71 in)	143 mm (5.63 in)	58.8 mm (2.31 in)

Note:

The outer diameter of the reel cutter (cutting cylinder) shaft is 25.4 mm (1.00 in).

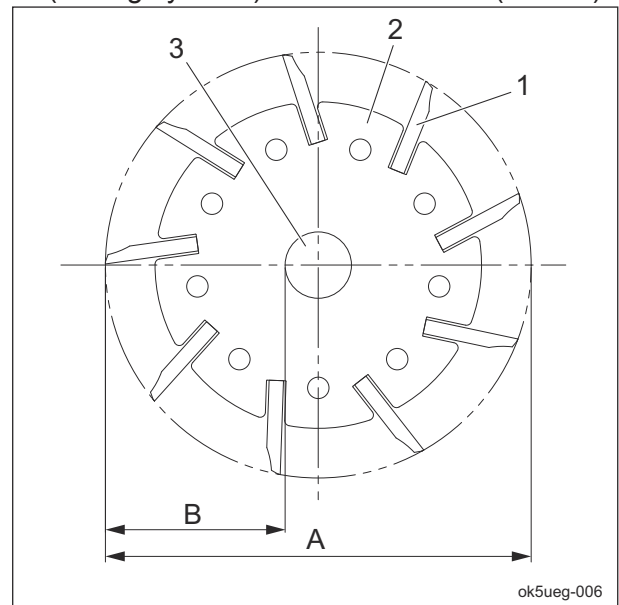

Replacement of Reel Cutter (Cutting Cylinder)_001

1	Reel cutter (cutting cylinder) blade
2	Reel cutter (cutting cylinder) disc
3	Reel cutter (cutting cylinder) shaft
A	Outer diameter of reel cutter (cutting cylinder)
B	Distance from blade edge to outer edge of reel cutter (cutting cylinder) shaft

Replacement of Bed Knife (Bottom Blade)

⚠ Caution

Both the reel cutter (cutting cylinder) and the bed knife (bottom blade) are edged tools. Handle them carefully, since they could cut your hands and feet.

⚠ Caution

Wear gloves when touching edged tools to avoid cutting your hands.

The criteria for replacing the bed knife (bottom blade) are described below.

1. When the reel cutter (cutting cylinder) is ground
2. When the reel cutter (cutting cylinder) is replaced
3. When the bed knife (bottom blade) is worn
High-speed-steel-tipped blade
Replace the bed knife (bottom blade) before it no longer has a tip.

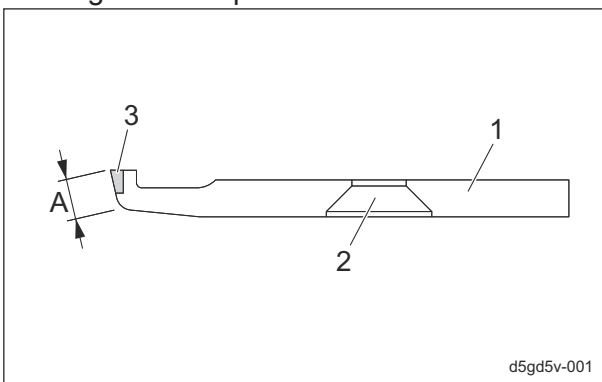

Replacement of Bed Knife (Bottom Blade)_001

1	Bed knife (bottom blade)
2	Mounting hole
3	Tip
A	Front face

Storage

Long-Term Storage

Follow the instructions below for long-term storage of the machine.

1. Cleaning

- Remove dirt, grass clippings, oil stains etc. completely from the main vehicle and engine.

2. Replacing oil

- Inspect and replace the engine oil and element.

3. Greasing and lubricating

- Supply oil and apply grease to appropriate parts.

4. Fuel

- Remove the fuel from the fuel tank.

5. Tire pneumatic pressure

- Set the tire air pressure slightly higher than normal, and then place the machine on a board to avoid humidity.

6. Mower units

- When storing this machine, lower all the mower units unless a positive mechanical lock is provided.

7. Storage location

- Cover the machine and store it in a dry place where it will not be exposed to rain.

Precautions for Repair Page 7-2

Adjustment Page 7-2

Adjustment of Parking Brake Page 7-2

Adjustment of Brake Page 7-3

Adjustment of Diff-lock Page 7-4

Adjustment of Mower Stopper Page 7-4

Adjustment of Mower Hook Page 7-4

Towing Page 7-5

Towing The Machine in An
Emergency Page 7-5

Repair

Precautions for Repair

Warning

The chapter "Repair" in this manual describes practical measures which should be performed by a mechanic with expertise. The owner should instruct the mechanic with expertise to perform repair service for this machine.

Caution

First, learn well the operations you plan to perform.

Important

Use tools appropriate for each operation.

Important

Use Baronesse genuine parts for replacement and accessories. Our product warranty may be void if you use non-genuine parts for replacement or accessories.

Adjustment

Adjustment of Parking Brake

Caution

If the brake wire is cut, the machine will be unable to stop. If the brake wire is cracked or damaged, replace it with a new one immediately.

Caution

If the parking brake is not sufficiently effective when you pull the parking brake lever, adjust the brake wire.

Important

Make sure that the brake is effective on slopes and that it is not applied any longer when you release it. Adjust the parking brake system whenever there is any abnormality.

Adjust the parking brake by the brake wire adjustment bolt.

1. While pressing the push button, return the parking brake lever to its resting position to release the parking brake.
2. Loosen the nut on the parking brake lever side.
3. Move the adjustment bolt toward the rear to increase the wire tension.
4. Tighten the nut securely to fix the adjustment bolt.
5. Make sure that the brake is applied properly when you pull the parking brake lever, and that there is no brake dragging when you release the parking brake lever.

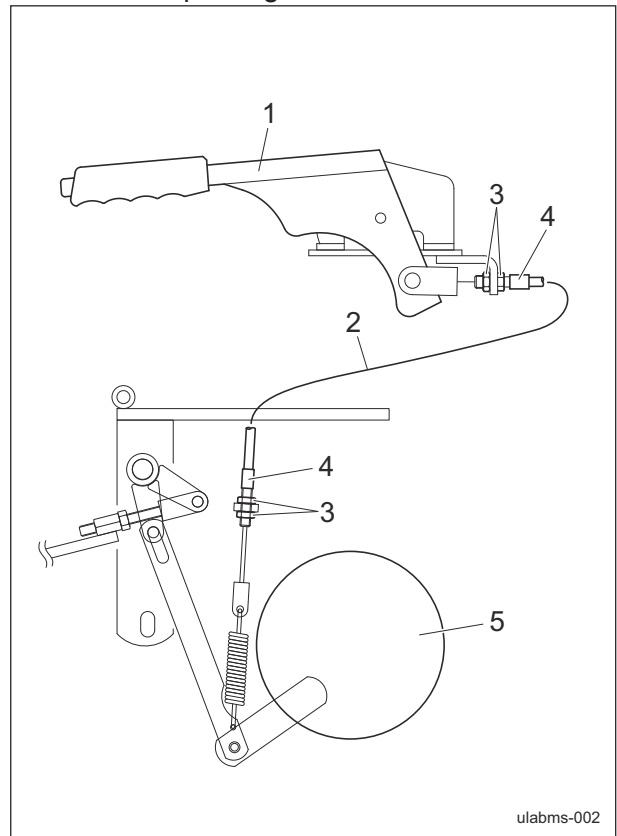

Adjustment of Parking Brake_001

1	Parking brake lever
2	Brake wire
3	Nut
4	Adjustment bolt
5	Brake drum

Note:

You can also adjust the brake wire on the transmission side.

Adjustment of Brake

⚠ Caution

If the brake is not applied effectively even if you depress the pedal up to the stopper, adjust the brake rod.

1. Pull the parking brake lever completely and make sure that the brake is effectively applied.
2. Loosen the lock nut.
3. Remove the cotter pin, washer and pin that affix the brake pedal to the front of the brake rod.
4. Screw in the nut on the front of the brake rod, then temporarily affix the brake pedal to the front of the brake rod using the pin.
5. Depress the brake pedal lightly, and adjust the clearance between the pedal stopper and brake pedal to 5 - 7 mm (0.20 - 0.28 in). (If the clearance is larger than 7 mm (0.28 in), the brake may be damaged.)
6. Affix the brake pedal to the front of the brake rod securely using the pin.
7. Tighten the lock nut to secure the front of the brake rod firmly.
8. Make sure that the brake is not applied any longer when you release the brake pedal.

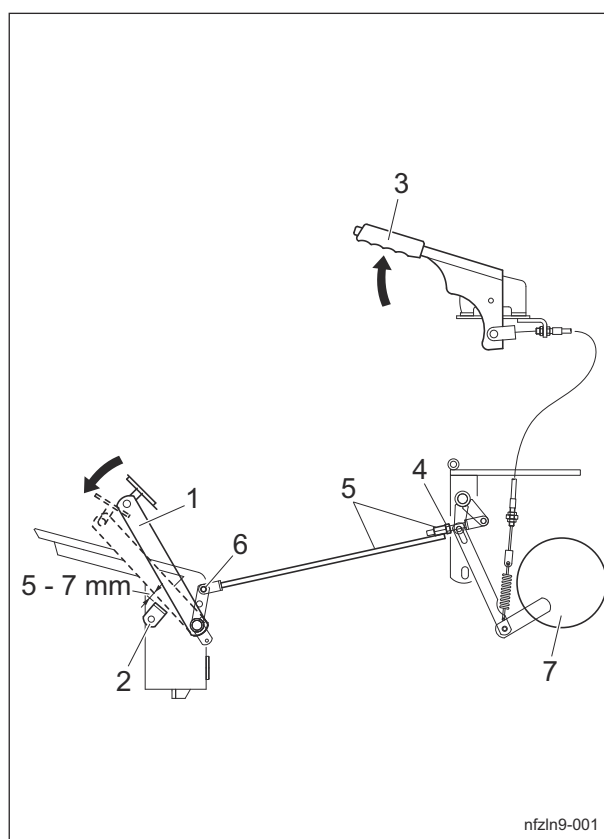

Adjustment of Brake_001

1	Brake pedal
2	Pedal stopper
3	Parking brake lever
4	Lock nut
5	Brake rod (front)
6	Cotter pin, washer, pin
7	Brake drum

Repair

Adjustment of Diff-lock

Important

If the diff-lock seems ineffective when you depress the diff-lock pedal, adjust the diff-lock wire.

1. Make sure that the diff-lock pedal has completely returned to its resting position.
2. Loosen the nut on the transmission side.
3. Loosen the adjustment bolt upward to increase the wire tension.
4. Adjust the wire so that the diff-lock wire and the diff-lock lever show a little play when the lever returns to its resting position under spring tension.
5. Tighten the nut and fix the adjustment bolt completely.

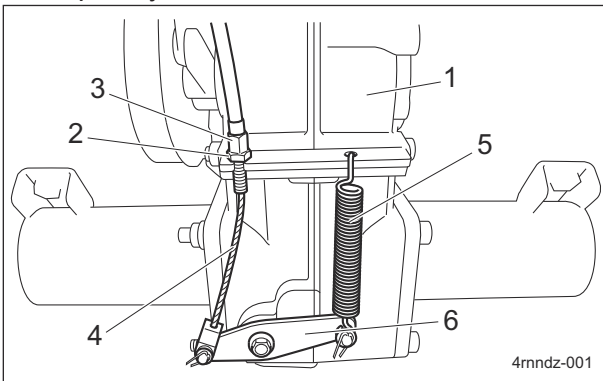

Adjustment of Diff-lock_001

1	Transmission
2	Nut
3	Adjustment bolt
4	Wire
5	Spring
6	Diff-lock lever

Note:

You can also adjust the diff-lock wire on the pedal side.

Adjustment of Mower Stopper

1. Lower the left and right mower units, then engage the reel rotation lever.
2. Loosen the nut, then adjust the position of the adjustment bolt so that the mower stopper will be positioned at 90 degrees against the frame.
3. Tighten the nut securely to fix the adjustment bolt.

4. Make sure that the mower stopper will spring back when you release the reel rotation lever.

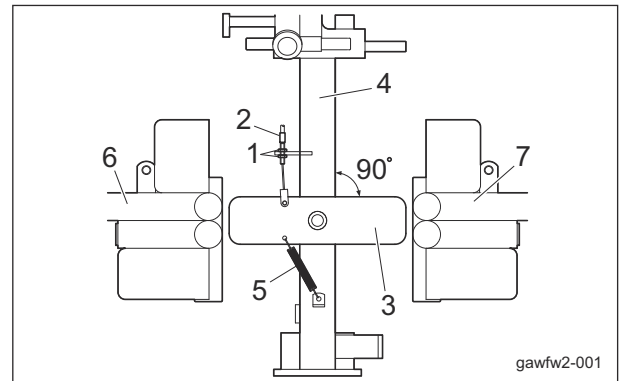

Adjustment of Mower Stopper_001

1	Nut
2	Adjustment bolt
3	Mower stopper
4	Frame
5	Spring
6	Left mower lifting arm
7	Right mower lifting arm

Adjustment of Mower Hook

Adjustment of Right and Left Mower Hooks

1. Loosen the nuts and move the adjustment bolt toward the outside of the machine to increase the wire tension.
2. Without gripping the clutch lever, raise the right mower unit, then make adjustment so that the hook metal fitting will be in touch with the bottom of the hook and the wire will have a small play.
3. Tighten the nuts and fix the adjustment bolt securely.
4. Follow the same steps to adjust the hook wire of left mower.

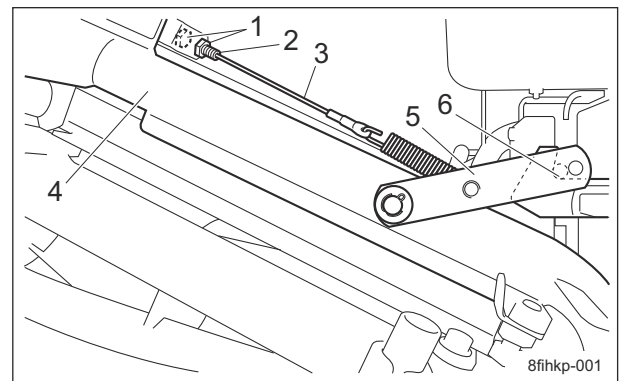

Adjustment of Right and Left Mower Hooks_001

1	Nut
2	Adjustment bolt
3	Wire (to hook the mower)
4	Right mower unit
5	Hook metal fitting
6	Bottom of the hook

Adjustment of Rear Mower Hook

1. Loosen the nuts and move the adjustment bolt toward the center of the machine to increase the wire tension.
2. Lower the rear mower unit, then adjust the hook metal fitting to come into contact slightly with the lever mounting bracket when you grip the clutch lever completely.
3. Tighten the nuts and fix the adjustment bolt securely.

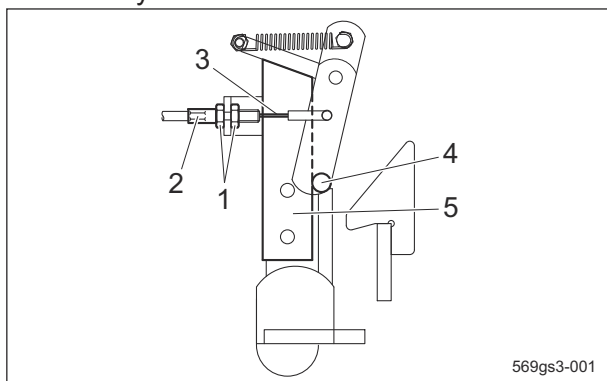

Adjustment of Rear Mower Hook_001

1	Nut
2	Adjustment bolt
3	Wire
4	Hook metal fitting
5	Lever mounting bracket

4. When the hook metal fitting returns to its original position by spring tension as soon as you release the lever, raise the rear mower lifting arm and make sure that the hook metal fitting is located closer to the center of the machine than the upper tip of the hook.

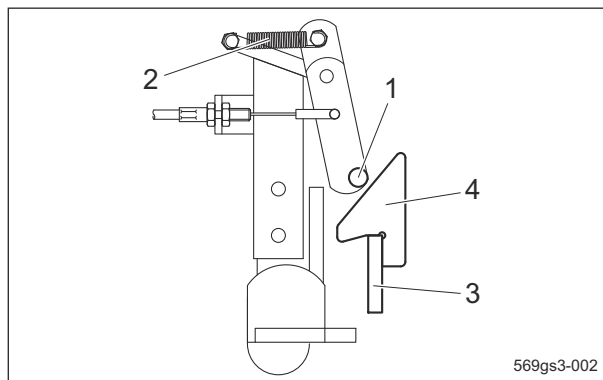

Adjustment of Rear Mower Hook_002

1	Hook metal fitting
2	Spring
3	Rear mower lifting arm
4	Hook

Towing

Towing The Machine in An Emergency

If the machine does not travel due to engine trouble, etc., you can move it in the following ways:

- Pushing by hand
- Towing (See the following instruction.)

1. Stop the engine.
2. Apply the parking brake.
3. Chock the wheels.
4. Secure the rope to the front part of the frame.

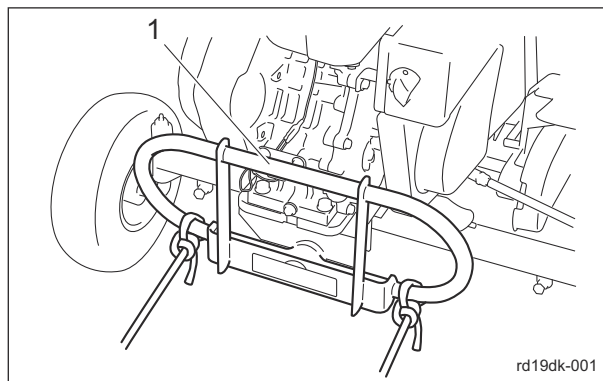

Towing The Machine in An Emergency_001

1	Frame
---	-------

5. Raise all mower units.

Repair

6. Set the change lever to the "Neutral" position.
7. Remove the wheel stoppers.
8. Release the parking brake.

 **Warning**

While towing, always keep your foot on the brake pedal and depress the brake pedal at any time to stop.

9. Tow the machine slowly.

Appended Table

Tightening TorquesPage 8-2
 Standard Tightening TorquesPage 8-2
 Principal Tightening Torques Page 8-4

Daily Check List Page 8-5

Maintenance Schedule Page 8-6

List of Adjusted Values Page 8-7

Appended Table

Appended Table

Tightening Torques

Important

Refer to the Tightening Torque table.
Note that the Baroness product warranty may not apply to defects caused by incorrect or overtorque tightening, etc.

Standard Tightening Torques

Bolts and Nuts



Important

A number of bolts are used in each part of this machine.
Be sure to re-tighten the bolts and nuts, because they may be loosened at the earlier stage of the use.

- As to the bolts and nuts without any special instruction, tighten them in appropriate tightening torque with proper tool.
Too much tightening may cause the looseness or damage of the screw.
- The strength of tightening is determined by types of screws, strength, the friction of thread face or base face and others.
The table below is for the galvanized or parkerized bolts.
In case that the strength of internal thread is weak, it is not applied.
- Do not use rusty or sand attached "screw."
Otherwise, it may cause insufficient tightening even if you apply the specified tightening torque.
The friction of the screw face becomes higher and the tightening torque is canceled out by the friction, therefore sufficient tightening cannot be applied.
- If "screw" is wet by water or oil, do not tighten it with normal tightening torque.
If the screw is wet, the torque coefficient will get smaller and it may result in too much tightening.
Too much tightening may cause looseness by the screw stretched or result in damage.
- Do not use a bolt experienced too much burden.
- Using the impact wrench requires the skill.
Do exercise as much as possible for steady tightening.

Appended Table

Nominal diameter	General bolt		
	Strength classification 4.8		
	 tib3yb-001		
	N-m	kgf-cm	lb-in
M5	3 - 5	30.59 - 50.99	26.55 - 44.26
M6	7 - 9	71.38 - 91.77	61.96 - 79.66
M8	14 - 19	142.76 - 193.74	123.91 - 168.17
M10	29 - 38	295.71 - 387.49	256.68 - 336.34
M12	52 - 67	530.24 - 683.20	460.25 - 593.02
M14	70 - 94	713.79 - 958.52	619.57 - 831.99
M16	88 - 112	897.34 - 1142.06	778.89 - 991.31
M18	116 - 144	1,182.85 - 1,468.37	1,026.72 - 1,274.54
M20	147 - 183	1,498.96 - 1,866.05	1,301.10 - 1,619.73
M22	295	3,008.12	2,611.05
M24	370	3,772.89	3,274.87
M27	550	5,608.35	4,868.05
M30	740	7,545.78	6,549.74

Nominal diameter	Heat-treated bolt					
	Strength classification 8.8			Strength classification 10.9		
	 tib3yb-002			 tib3yb-003		
	N-m	kgf-cm	lb-in	N-m	kgf-cm	lb-in
M5	5 - 7	50.99 - 71.38	44.26 - 61.96	7 - 10	71.38 - 101.97	61.96 - 88.51
M6	8 - 11	81.58 - 112.17	70.81 - 97.36	14 - 18	142.76 - 183.55	123.91 - 159.32
M8	23 - 29	234.53 - 295.71	203.57 - 256.68	28 - 38	285.52 - 387.49	247.83 - 336.34
M10	45 - 57	458.87 - 581.23	398.30 - 504.51	58 - 76	591.43 - 774.97	513.36 - 672.68
M12	67 - 85	683.20 - 866.75	593.02 - 752.34	104 - 134	1,060.49 - 1,366.40	920.50 - 1186.03
M14	106 - 134	1,080.88 - 1,366.40	938.21 - 1,186.03	140 - 188	1,427.58 - 1,917.04	1,239.14 - 1,663.99
M16	152 - 188	1,549.94 - 1,917.04	1,345.35 - 1,663.99	210 - 260	2,141.37 - 2,651.22	1,858.71 - 2,301.26
M18	200 - 240	2,039.40 - 2,447.28	1,770.20 - 2,124.24	280 - 340	2,855.16 - 3,466.98	2,478.28 - 3,009.34
M20	245 - 295	2,498.27 - 3,008.12	2,168.50 - 2,611.05	370 - 450	3,772.89 - 4,588.65	3,274.87 - 3,982.95
M22	-	-	-	530	5,404.41	4,691.03
M24	-	-	-	670	6,831.99	5,930.17
M27	-	-	-	1,000	10,197.00	8,851.00
M30	-	-	-	1,340	14,628.78	11,860.34

Note:
The same values are applied to "fine screw thread."

Appended Table

Principal Tightening Torques

Tightening Torque by Model

LM180E

Tighten the following bolts and nuts at the torque specified in the table.

For thread locking adhesive, apply a mild to high-strength thread locker (ThreeBond 1322 or equivalent anaerobic sealant).

Portion		Code	Part name	Tightening Torque			Thread locking adhesive
				N-m	kgf-cm	lb-in	
Front wheel	Front wheel shaft	K0071000082	Bolt, with nipple hole M12-15	36 - 40	371.13 - 407.92	318.64 - 354.04	—
	Wheel mounting shaft	K0000100252	Bolt, M10-25	29 - 38	295.71 - 387.49	256.68 - 336.34	—
	Wheel	K0000080202	Bolt, M8-20	14 - 19	142.76 - 193.74	123.91 - 168.17	—
Rear wheel	Wheel	K0010100252	Bolt, heat-treated M10-25	58 - 76	591.43 - 774.97	513.36 - 672.68	—
Steering		K1604120000	Rod end, spherical bearing LHSA12	52 - 67	530.24 - 683.20	460.25 - 593.02	○
Handle		K0010060202	Bolt, heat-treated M6-20	7 - 9	71.38 - 91.77	61.96 - 79.66	—
Transmission pulley		K0010060152	Bolt, heat-treated M6-15	7 - 9	71.38 - 91.77	61.96 - 79.66	○
Mower unit	Bed knife (Bottom blade)	K0071001182	Screw, heat-treated flathead M10-16	29 - 38	295.71 - 387.49	256.68 - 336.34	—
	Front roller	K0010100252	Bolt, heat-treated M10-25	58 - 76	591.43 - 774.97	513.36 - 672.68	—

Daily Check List

LM180E

- . . . Inspect, adjust, supply, clean (first time)
- . . . Inspect, adjust, supply, clean
- ▲ . . . Replace (first time)
- △ . . . Replace

Maintenance Item		Before Work	After Work	Remarks
Engine	*1	Check engine oil	○	
	*1	Check fuel	○	
	*1	Check air cleaner	○	
	*1	Check fuel strainer (fuel cock)	○	
	*1	Check liquid leakage	○	
	*1	Check engine area	○	
	*1	Check bolts and nuts	○	
	*1	Clean air cleaner		○
Main vehicle		Check tire	○	
		Check cover	○	
		Check wire	○	
		Check brake pedal	○	
		Check brake lever	○	
		Check brake	○	
		Check diff-lock pedal	○	
		Check clutch lever	○	
		Check reel rotation lever	○	
		Check mower stopper	○	
		Check change lever	○	
		Check steering handle	○	
		Check safety device	○	
		Check liquid leakage	○	
		Check machine exterior	○	
		Check bolts and nuts	○	
	Clean machine exterior		○	
Mower unit		Check reel cutter and bed knife	○	
		Check roller	○	
		Check cover	○	
		Check mower unit exterior	○	
		Check mower hook metal fitting	○	
		Check bolts and nuts	○	
		Clean mower unit		○

· *1: Refer to the Engine's Owner's Manual.

Appended Table

Maintenance Schedule

LM180E

● . . . Inspect, adjust, supply, clean (first time)

○ . . . Inspect, adjust, supply, clean

▲ . . . Replace (first time)

△ . . . Replace

Maintenance Item		Before Work	After Work	Every 25 hrs.	Every 50 hrs.	Every 100 hrs.	Every 300 hrs.	Every 500 hrs.	Every year	When Required	Remarks
Engine	*2	Check spark plug				○					
	*2	Clean sediment cup				○					
	*1	Clean fuel tank & filter					○				
	*1	Check valve clearance					○				
	*1	Remove carbon in combustion chamber					○				
		Check fuel hoses and clamp bands							○		
	*2	Replace engine oil			▲	△					
		Check fuel hoses and clamp bands									△
	*2	Clean air cleaner element									△
Main vehicle		Check spark plug									△
		Check belt	○								
		Check electrical wiring				●	○				
		Check wheel mounting bolt				●	○				
		Check transmission oil								○	When leakage found
		Grease and Lubricate				○					
		Replace transmission oil					▲		△		
		Replace belt									△
		Check brake wire									△
		Check diff-lock wire									△
		Check mower stopper wire									△
		Check throttle wire									△
Mower unit		Replace brake shoe									△
		Check engage blades	○								
		Check mowing height	○								
		Grease and Lubricate				○					
		Engage blades									○
		Adjust mowing height									○
		Backlap blades									○
	Regrind blades (Reel cutter)									○	

- *1: Consult your local Baroness Dealer for this service.

- *2: Refer to the Engine's Owner's Manual.

- The values for consumables are not guaranteed.

List of Adjusted Values

Diff-lock wire		Create a slight play	
Brake pedal		5 - 7 mm (0.20 - 0.28 in)	Clearance between pedal stopper and brake pedal
Belt	Traveling clutch	7 - 8 mm (0.28 - 0.31 in)	Clearance between rod-tension metal fitting and collar
	Reel rotation lever	7 - 8 mm (0.28 - 0.31 in)	Clearance between rod-tension metal fitting and collar
	Left and Right Mower Units	1 mm (0.04 in)	Clearance between collar and mower lifting arm
	Transmission	Approximately 10 mm (0.39 in)/98 N (10 kgf)	Belt slack
	Rear mower tension	1 mm (0.04 in)	Clearance of spring
	Rear Mower Unit	Approximately 10 mm (0.39 in)/98 N (10 kgf)	Belt slack
Left / right mower stopper		90°	Angle against the frame
Wire to hook the rear mower		The hook metal fitting should contact with the lever mounting bracket slightly.	
Wire to hook the left / right mower		Create a slight play	The hook metal fitting should contact with the bottom of the hook.

Appended Table

BARONESS[®]
Quality on Demand

 **KYOEISHA CO., LTD.**
Head Office 1-26, Miyuki-cho, Toyokawa-city, Tel :+81-533-84-1390
Aichi-pref, 442-8530 JAPAN Fax:+81-533-84-1220