

APB311

Push Brush Unit

Parts catalog

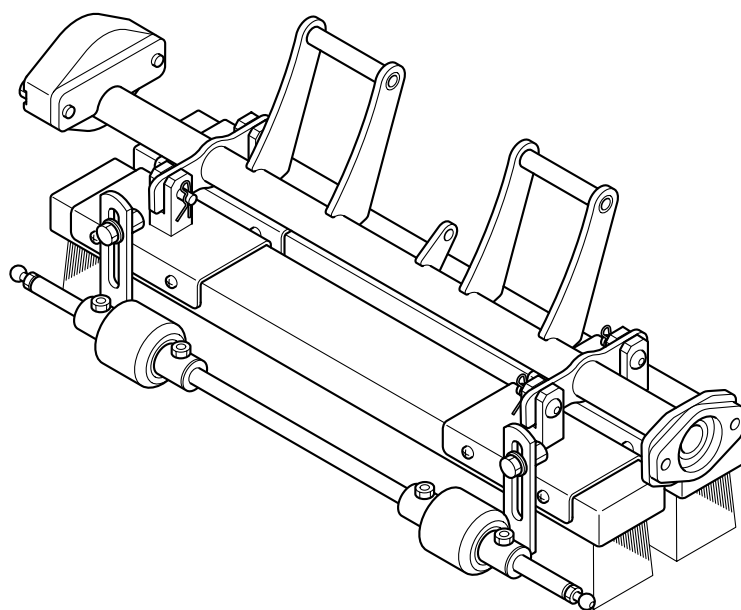

BARONESS[®]
Quality on Demand

Serial No. APB311 : 10001-

Ver.1.0

Greetings

Thank you for purchasing Baroness product.

This brochure contains the information needed for ordering BARONESS parts.

Search the number indicating the figure of your desired part in the illustration area, and find the same number from among the latter parts of the hyphenated Cat Nos. in the listing area to obtain the individual Code No.

Notes

1) For inquiries of parts

Inform us of the model and the serial number of your machine or attachment.

The model and the serial number are indicated on the serial number plate of your machine or attachment.

* Consult the Owner's Operating Manual for the position where the serial number plate is affixed.

2) For ordering parts

- Inform us of the Code No., Part name and order quantity.
- We do not accept returns unless our company is responsible for the issue.
- Use genuine Baroness parts and accessories. The Baroness product warranty may not apply if parts or accessories from other companies are used.

3) The information described in this brochure is subject to change without prior notice.

Description of the content of Parts catalog

1) Illustration area

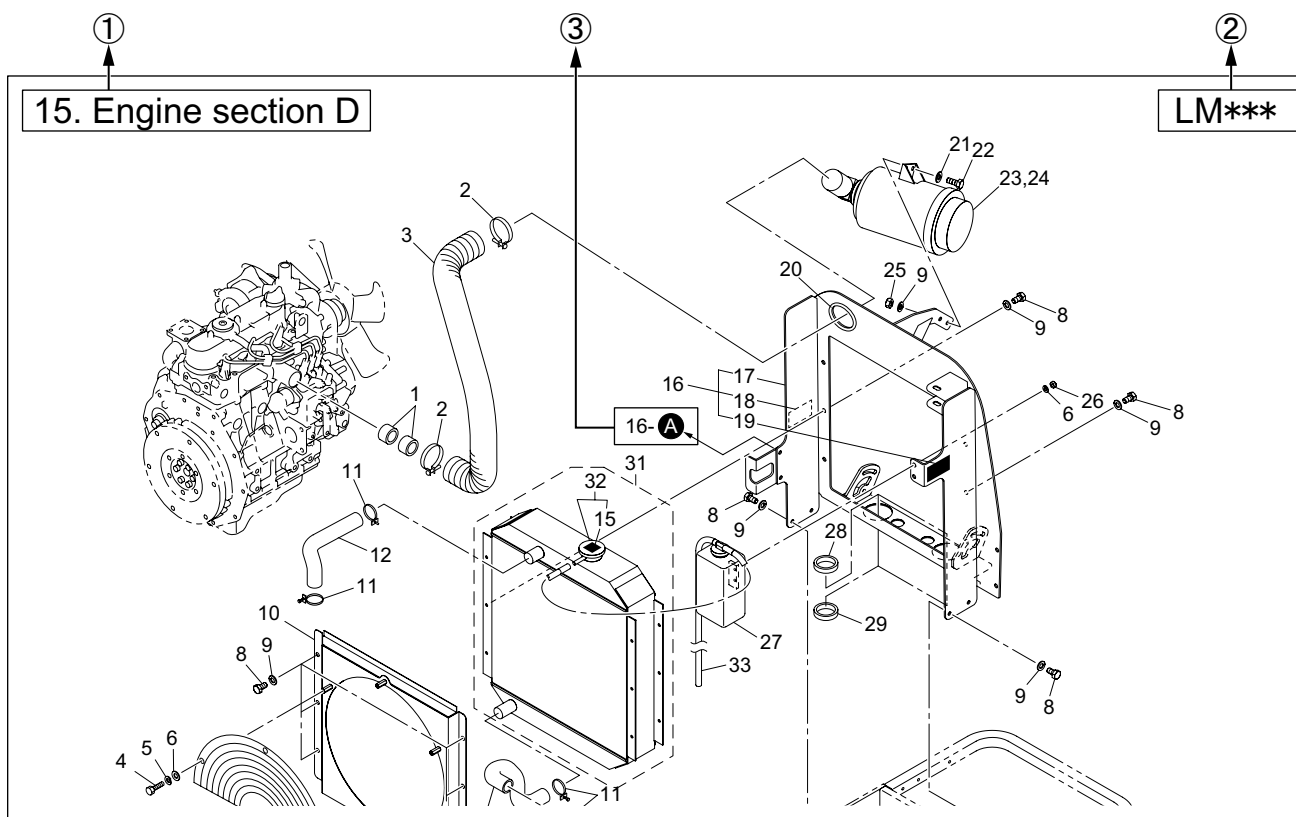

- ① Section No. /Section name
- ② Model
- ③ Indication of the connecting point

The following indication shows the connecting point of the part shown on the other page.

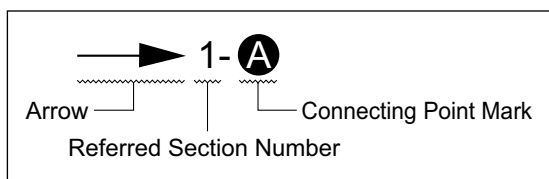

- 1- **A** :
Refer to the point **A** in the illustration of the section No.1
- 2- **B** :
Refer to the point **B** in the illustration of the section No.2

Note :

The figures of assembled components or isolated parts do not always show their accurate shapes. The figures are supposed to be used for obtaining the correct code numbers.

2) Listing area

Cat No.	Code No.	Part name	Qty			Remark	SN of application
1 - 1	K0000080152	BOLT, M8-15	2	2	2		
1 - 2	K0185160002	NUT, LEFT-HANDED P1.5 M16-3	2	2	2		
1 - 3	K3650000100	HOUR METER, HH2AS	1	1	1		10001-10023
1a- 3	K3650000130	HOUR METER, 636DC	1	1	1		10024-
1 - 4	K0100060002	NUT, M6	2	2	2		
1 - 5	K0003080702	BOLT, M8-70	1	1	1		
1 - 7	K0830000020	OIL SEAL, 254210	2	2	2		

① Cat No. or Catalog No.

Find the same number as the number indicating the figure of your desired part in the illustration area from among the latter parts of the hyphenated Cat Nos. to obtain the individual Code No.

② Code No.

Identification code of an individual part

③ Part name

④ Qty

Quantity needed per Cat No.

⑤ Model

When the quantity differs by models, the models are indicated.

⑥ Remark

Specification or description, etc. of the part may be indicated.

⑦ SN of application

In case of part alteration, the serial number ranges of machines to which the alteration is applied will be indicated.

3) Indication in case of part alteration

- When a new part and an old one are interchangeable with each other, indication of the old part code No. is discontinued and the new part code No. is solely indicated.
- When a new part and an old one are not interchangeable, the serial number ranges of both machines where the new part is used and those where the old one is used are indicated in the SN of application column.
- When a part is newly added, the serial number range of machines where the part is used is indicated in the SN of application column.
- When a part was previously used but the part is not used in the machine any longer, the serial number range of machines where the part was used is indicated in the SN of application column.

Contents

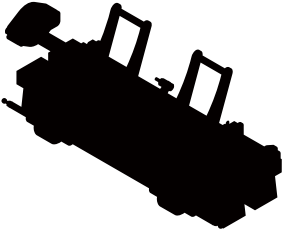
1. Push brush Unit section.....1 	2. Accessories2
---	-----------------------

1. Push brush Unit section

APB311

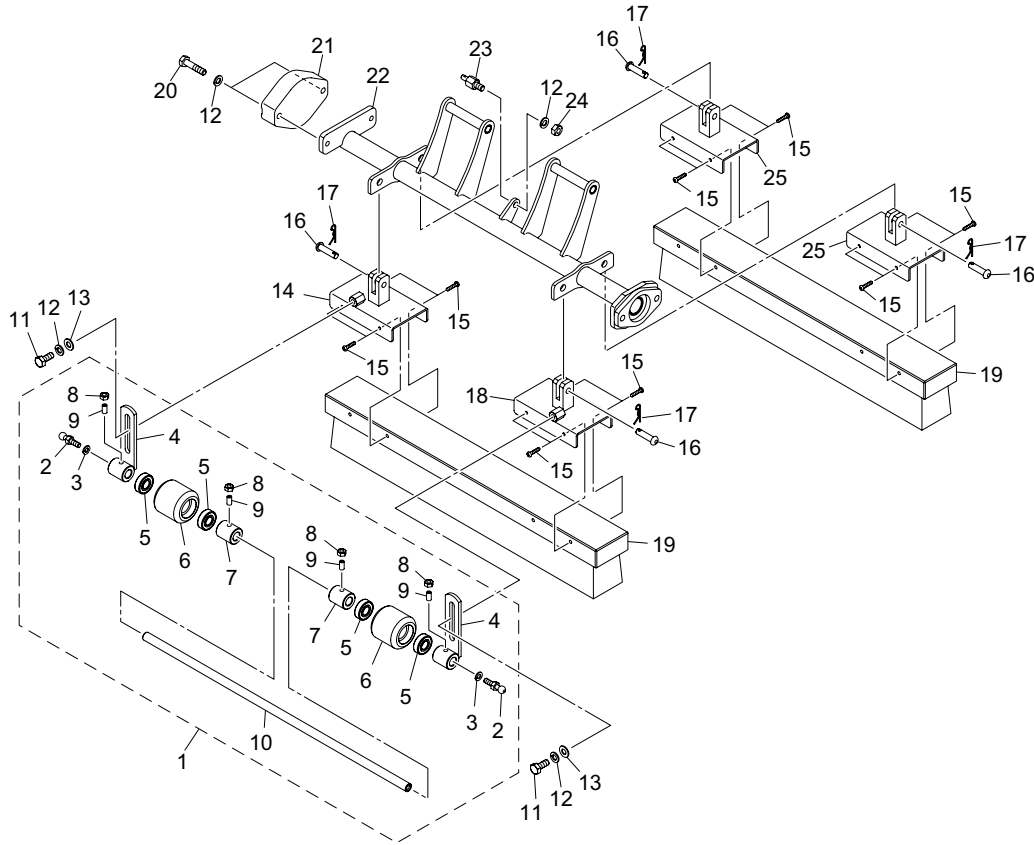

APB311_001_z00

Cat No.	Code No.	Part name	Qty	Remark	SN of application
1-1	LM315GB4306Z0	ROLLER COMP, FRONT	1		
1-2	LM315GA1841Z2	BOLT, MOUNTING MOWER	2		
1-3	K0200080002	WASHER, SPRING M8	2		
1-4	LM315GB4308ZD	FITTING, HOISTING ROLLER	2		
1-5	K0612062020	BEARING, BALL SEAL 2RD 6202	4		
1-6	K2100000040	ROLLER, ALUMINUM 60-60	2		
1-7	K6218000722	COLLAR, TAPPED 15.1-30-35	2		
1-8	K0100080002	NUT, M8	4		
1-9	K0023080151	SETSCREW, M8-15	4		
1-10	LM315GB4307Z2	SHAFT, ROLLER	1		
1-11	K0000100252	BOLT, M10-25	2		
1-12	K0200100002	WASHER, SPRING M10	5		
1-13	K5000100002	WASHER, M10	2		
1-14	LM315GB4305ZD	CLAMPER, BRUSH (RH)	1		
1-15	K0069000232	SCREW, TAPPNIG PAN-HEAD 5-25	16		
1-16	K6041100392	PIN, ROUND HEAD HT M10-39	4		
1-17	K0331000008	PIN, SNAP M10	4		
1-18	LM315GB4304ZD	CLAMPER, BRUSH (LH)	1		
1-19	K4150000240	BRUSH, 65-0.6-5	2		
1-20	K0000100452	BOLT, M10-45	2		
1-21	K690300017D	COVER, REEL HOUSING	1		
1-22	APB311-0103ZD	BRACKET, BRUSH FOOKING	1		
1-23	LM54G--0614Z3	BOLT, HOLDING CHAIN	1		
1-24	K0100100002	NUT, M10	1		
1-25	LM315GB4303ZD	CLAMPER, BRUSH	2		

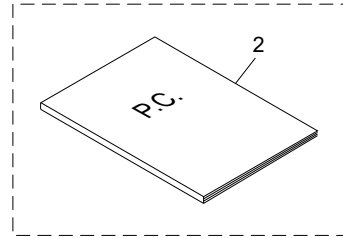
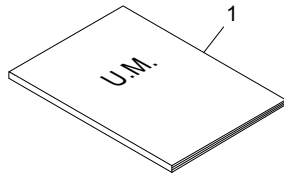

APB311_002_z00

Cat No.	Code No.	Part name	Qty	Remark	SN of application
2a-1	APB311--UM--00Z	O-MANUAL, APB311 JP-EN	1		
2a-2	APB311--PC--00Z	P-CATALOG, APB311 JP-EN	1	Available for sale	

BARONESS[®]
Quality on Demand

 **KYOEISHA CO., LTD.**
Head Office 1-26, Miyuki-cho, Toyokawa-city, Tel :+81-533-84-1390
Aichi-pref, 442-8530 JAPAN Fax :+81-533-84-1220