

GM1700

Mid-Mount Rotary Mower

Owner's Operating Manual

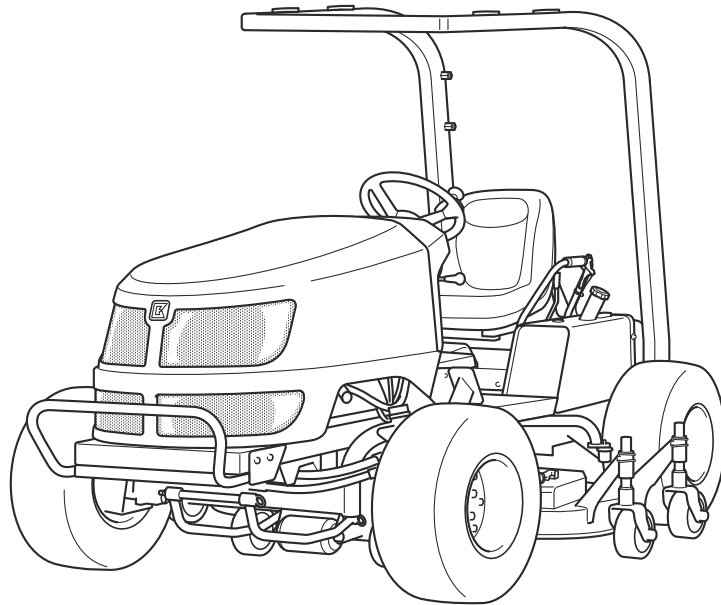

Serial No. GM1700 : 21241-

"Required reading"
Read this manual before using the machine.

BARONESS[®]
Quality on Demand

Original Instructions Ver.1.9

Regulations

California Proposition 65

(For California, USA)

WARNING:

Operating, servicing and maintaining a passenger vehicle or off-road vehicle can expose you to chemicals including engine exhaust, carbon monoxide, phthalates, and lead, which are known to the State of California to cause cancer and birth defects or other reproductive harm. To minimize exposure, avoid breathing exhaust, do not idle the engine except as necessary, service your vehicle in a well-ventilated area and wear gloves or wash your hands frequently when servicing your vehicle. For more information go to www.P65Warnings.ca.gov/passenger-vehicle.

318yi8-005

California Proposition 65_001

California Spark Arrester

(For California, USA)

Warning

Operation of this equipment may create sparks that can start fires around dry vegetation.
A spark arrester may be required.
The operator should contact local fire agencies for laws or regulations relating to fire prevention requirements.

It is a violation of California Public Resource Code Section 4442 or 4443 to use or operate the engine on any forest-covered, brush-covered, or grass-covered land unless the engine is equipped with a spark arrester, as defined in Section 4442, maintained in effective working order or the engine is constructed, equipped, and maintained for the prevention of fire pursuant to Section 4443.

The engine of this machine is not equipped with a spark arrester.

In some areas there are local, state, or federal regulations requiring that a spark arrester be used on the engine of this machine.

The recommended spark arrester for this machine is Part No.49024N Spark Arrester made by Nelson Global Products.

EU Regulations

(For EU)

This product complies with all relevant EU Regulations.

For more information, please refer to the Declaration of Conformity attached.

Thank you for purchasing the Baroness product. This manual describes the proper handling, adjustment, and inspection of your product. We hope you will use the product safely, and take advantage of its best performance. For details on the handling, adjustment and inspection of the attachments, refer to the Owner's Operating Manual for the attachments.

Keeping the Owner's Operating Manual

Keep this Manual in the box on the hydraulic tank.

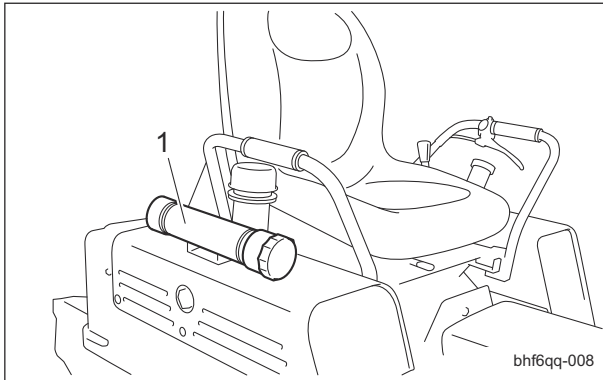

Keeping the Owner's Operating Manual_001

1	Box
---	-----

QR Code

A QR code label is affixed on the machine.

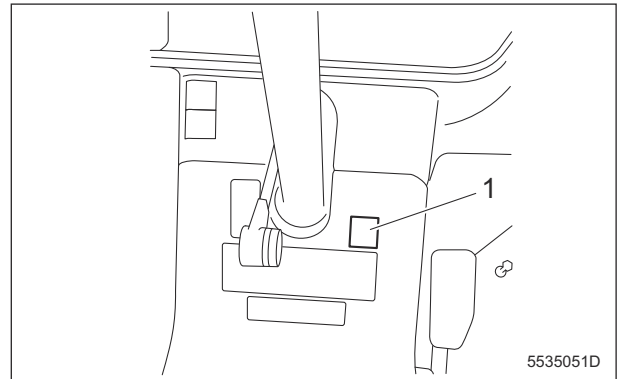

QR Code_001

1	QR code label
---	---------------

Scan the QR code with your smartphone for easy access to Baroness Manual Reference Service where you can browse Owner's Operating Manual and Parts Catalog.
<https://doc.baroness-international.com/manuals/GM1700>



QR Code_002

Introduction

Read this manual carefully to ensure that you thoroughly understand how to properly operate and maintain the product, and to avoid causing injury to yourself or others.

The operator is responsible for operating the product properly and safely.

Maintenance service for this machine should be performed by a mechanic with expertise.

If you have any questions concerning maintenance or genuine parts, please contact a Baroness dealer or Kyoisha.

When making inquiries about your product, please specify the model and serial number.

When loaning or transferring the product, please also provide this manual together with the product.

Kyoisha Co., Ltd.

Warning Symbols

This manual uses the following warning symbols for handling precautions that are important for your safety.



696cq5-001

Warning symbol

This symbol indicates the articles regarding “Danger,” “Warning,” or “Caution.”

Those articles describe important safety precautions and so read them carefully to understand completely before operating the machine.

Failure to adequately follow these safety precautions may cause an accident.

Danger

This symbol indicates that serious injury or death will occur if the warning is ignored.

Warning

This symbol indicates that serious injury or death may occur if the warning is ignored.

Caution

This symbol indicates that injury or damage to property may occur if the warning is ignored.

Important

This symbol indicates precautions on the mechanism of the machine.

Precautionary Statement

 Caution

The information described in this manual is subject to change for improvement without prior notice.

When replacing parts, be sure to use genuine Baroness parts or parts designated by Kyoeshia.

Note that the Baroness product warranty may not apply to defects caused by the use of parts from other companies.

Prior to use, carefully read the following manuals to thoroughly understand the contents for safe and correct operation.

- Baroness Owner's Operating Manual
- The Engine's Owner's Manual
- The Battery's Owner's Manual

Purpose

This product is intended for cutting turf grass at golf courses.

Do not use this product in any way other than its intended purpose, and do not modify this product.

Operating this product for other purposes and modifying it may be very dangerous and may cause damage to the product.

In addition, this product is not authorized for operation as a special motor vehicle. Do not operate it on public roads.

GM1700

Introduction

Safety	Page 1-1	Lubrication	Page 6-6
Safe Operating Practices	Page 1-2	Adjustment and Replacement	Page 6-8
Disposal	Page 2-1	Storage	Page 6-19
Recycle and Waste Disposal	Page 2-2	Repair	Page 7-1
Product Overview	Page 3-1	Precautions for Repair	Page 7-2
Specifications	Page 3-2	Adjustment and Replacement	Page 7-2
Sound Pressure Level	Page 3-3	Towing	Page 7-6
Sound Power Level	Page 3-3	Appended Table	Page 8-1
Vibration Level	Page 3-3	Tightening Torques	Page 8-2
Carbon Dioxide (CO ₂) Emissions	Page 3-3	Maintenance Schedule	Page 8-6
Names of Each Section	Page 3-4	List of Adjusted Values	Page 8-7
Regulation Decals	Page 3-6	Records	Page 9-1
Safety Signs and Instruction Signs	Page 3-10	Maintenance Records	Page 9-2
Operation Decals	Page 3-15		
Description of Functions	Page 4-1		
Key Switch	Page 4-2		
Throttle Lever	Page 4-2		
Mower Deck Up/Down Switch	Page 4-2		
Knife Rotation Lever	Page 4-3		
2WD/4WD Selector Lever	Page 4-3		
Traveling Pedal	Page 4-3		
Brake Pedal	Page 4-4		
Parking Brake Lever	Page 4-4		
Instruments on the Operation Panel	Page 4-4		
Safety Mechanisms	Page 4-6		
Warning Buzzer	Page 4-6		
Handling Instructions	Page 5-1		
Pre-installation Adjustments	Page 5-2		
Operations Before Service	Page 5-2		
Inspection and Cleaning	Page 5-5		
Adjustment before Work	Page 5-16		
Start/Stop of Engine	Page 5-17		
Parking and Stopping	Page 5-18		
Move	Page 5-18		
Cutting Work	Page 5-19		
Transporting	Page 5-19		
Maintenance	Page 6-1		
Precautions for Maintenance	Page 6-2		
Jacking Up The Machine	Page 6-2		
Greasing	Page 6-3		

GM1700

Contents

Safe Operating Practices Page 1-2

Training Page 1-2

Preparation Page 1-2

Operation Page 1-3

Maintenance Page 1-4

Storage Page 1-5



Safety

Failure to adequately follow these safety precautions may cause an accident resulting in injury or death.

Danger

This product is designed to ensure safe operation and has been tested and inspected thoroughly before shipment from the factory. The product is equipped with safety devices to prevent accidents.

However, whether the product demonstrates its original performance level depends on the manner in which it is operated and handled, as well as the manner in which it is managed on a daily basis.

Inappropriate use or management of the product may result in injury or death.

Observe the following safety instructions to ensure safe operation.

Safe Operating Practices

Training

1. Read this manual and other training material carefully.

Be familiar with the controls, safety signs, and the proper use of the equipment.

2. If the operator or mechanic can not read the language used in this manual, it is the owner's responsibility to explain this material to them.

3. All operators and mechanics should seek and obtain professional and practical instruction.

The owner is responsible for training the users.

Such instruction should emphasize:

- [1] The need for care and concentration when working with ride-on machines.

- [2] Control of a ride-on machine sliding on a slope will not be regained by the application of the brake.

The main reasons for loss of control are

- Insufficient wheel grip
- Being driven too fast
- Inadequate braking
- The type of machine is unsuitable for its task
- Lack of awareness of the effect of ground conditions, especially slopes
- Incorrect hitching and load distribution

4. Never allow children or people unfamiliar with these instructions to use or service the machine.

Local regulations may restrict the age of the operator.

5. The owner/user can prevent and is responsible for accidents or injuries occurring to themselves, other people, or property.
6. Keep in mind that the owner, operator, and mechanic are responsible for accidents or hazards occurring to other people or their property.
7. The ROPS is an integral and effective safety device.
Do not remove or alter the ROPS.
8. Replace a damaged ROPS.
Do not repair or alter.
9. You can find additional safety information where needed throughout this manual.
10. Determine the left and right sides of the machine from the normal operating position.

Preparation

1. Evaluate the terrain to determine what accessories and attachments are needed to properly and safely perform the job.
Only use accessories and attachments approved by the manufacturer.
2. While operating, always wear substantial footwear, long trousers, hard hat, safety glasses, mask, and ear protection.
Long hair, loose clothing, or jewelry may get tangled in moving parts.
Do not operate the equipment when barefoot or wearing open sandals.
3. Inspect the area where the equipment is to be used and remove all objects such as rocks, toys and wire which can be thrown by the machine.
4. Keep children out of the operating area and under the watchful care of a responsible adult other than the operator.
5. Exercise care in the handling of fuel.

Warning

Fuel is highly flammable.

Take the following precautions:

- [1] Store fuel in containers specifically designed for this purpose.

- [2] Add fuel before starting the engine.
Never remove the cap of the fuel tank or add fuel while the engine is running or when the engine is hot.
- [3] Refuel outdoors only and do not smoke while refueling.
- [4] If fuel is spilled, do not attempt to start the engine but move the machine away from the area of spillage and avoid creating any source of ignition until petrol vapours have dissipated;
- [5] Replace all fuel tanks and container caps securely.
6. Check that operator's presence controls, safety switches and shields are attached and functioning properly.
Do not operate unless they are functioning properly.
7. If the brake operation is faulty, be sure to adjust or repair them before operating the machine.
8. If the handlebar has noticeable play, be sure to adjust or repair them before operating the machine.
9. Replace faulty mufflers.
10. Before using, always visually inspect to see that the rotary knives, rotary knife bolts, and cutter assembly are not worn or damaged. Replace worn or damaged rotary knives and bolts in sets to preserve balance.
11. On multi-rotary knife machines, take care as rotating one rotary knife can cause other rotary knives to rotate.
5. Never operate the machine with damaged guards, shields, or without safety protective devices in place.
Be sure all interlocks are attached, adjusted properly, and functioning properly.
6. Keep hands and feet away from the rotating parts.
7. Do not carry passengers.
8. Never operate while people, especially children, or pets are nearby.
9. Only operate in good light, keeping away from holes and hidden hazards.
10. Do not operate the machine when there is the risk of lightning.
11. Do not stop or start suddenly.
12. Look behind and down before backing up to be sure of a clear path.
13. Slow down and use caution when making turns and crossing roads and sidewalks.
14. Use care when approaching blind corners, shrubs, trees, or other objects that may obscure vision.
15. Do not take your eyes off the road ahead.
Do not operate the machine with no hands.
16. Remember there is no such thing as a safe slope.
Travel on grass slopes requires particular care.
To guard against overturning, follow these instructions.
- [1] Do not stop or start suddenly when going up or downhill.
- [2] Engage clutch slowly, always keep machine in gear, especially when traveling downhill.
- [3] Machine speeds should be kept low on slopes and during turns.
- [4] Stay alert for humps and hollows and other hidden hazards.

Operation

1. Do not operate the machine under the influence of alcohol or drugs.
2. Do not operate the engine in a confined space where dangerous carbon monoxide fumes can collect.
3. Be sure all drives and shift are in neutral and parking brake is engaged before starting engine.
Only start engine from the operator's position.
Use seat belts if provided.
4. Do not change the engine governor settings or overspeed the engine.
Operating the engine at excessive speed may increase the hazard of personal injury.
17. Never use the machine on a slope with an angle of gradient that is greater than that specified or in a place where there is a danger of the machine slipping.
18. Use extra care while operating machine with a grass catcher or other attachments.
They can affect the stability of the machine.
19. Disengage drive to the cutting unit(s), when other than operating.

Safety

20. Do the following before leaving the operator's position.
 - [1] Stop on level ground.
 - [2] Disengage the all drives.
 - [3] Lower the bucket.
 - [4] Set the parking brake.
 - [5] Stop the engine.
 - [6] Remove the ignition key.
21. Stop the engine in the following conditions.
 - [1] Before refuelling.
 - [2] Before removing the grass catcher.
 - [3] Before making height or depth adjustment unless adjustment can be made from the operator's position.
 - [4] Before clearing blockages.
 - [5] Before checking, cleaning or working on the machine.
 - [6] After striking a foreign object or if an abnormal vibration occurs.
Inspect the machine for damage and make repairs before restarting and operating the equipment.
22. Reduce the throttle setting during engine run-out.
23. Never operate with the discharge deflector raised, removed or altered, unless using a grass catcher.
24. Never raise mower deck with the rotary knives running.
25. Do not mow in reverse unless absolutely necessary.
26. Do not direct discharge material toward anyone.
Avoid discharging material against a wall or obstruction.
Material may ricochet back toward the operator.

27. Take care when loading or unloading the machine into a trailer or a truck.
Load or unload the machine in a flat and safe place.
Before loading or unloading, set the parking brake on the truck or trailer, stop the engine, and chock the wheels.
When transporting the machine on a truck or a trailer, set the parking brake, stop the engine, and fasten the machine to the truck with a rope or other suitable restraining device that has sufficient strength.
When using a running board, select one with sufficient strength, length, and width and that will not cause the machine to slip.
28. Close the fuel valve before transporting the machine.

Maintenance

1. Never allow untrained personnel to service machine.
2. Implement the following work before adjusting, cleaning or repairing.
 - [1] Stop the machine on level ground.
 - [2] Disengage drive to the cutting unit(s).
 - [3] Lower the cutting unit(s) and/or attachment(s).
 - [4] Set the parking brake.
 - [5] Stop the engine.
 - [6] Remove the ignition key.
 - [7] Wait for all movement to stop.
3. Allow the engine/muffler to cool before checking/maintenance.
4. To reduce the fire hazard, keep hot parts such as the engine and silencer/muffler, battery compartment and fuel storage area free of grass, leaves, or excessive grease.
Clean up oil or fuel spillage.
5. Appropriately manage and correctly use the tools necessary for servicing or adjusting the machine.
6. Disconnect battery before making any repairs.
Disconnect the negative terminal first and the positive last.
Reconnect positive first and negative last.
7. Use jack stands to support components when required.

8. Keep hands and feet away from moving parts.
If possible, do not make adjustments with the engine running.
9. Make sure that parts such as wires are not touching each other and that their covers have not come off.
10. Keep all parts in good working condition and all hardware tightened.
Replace all worn or damaged decals.
11. Keep all nuts, bolts and screws tight to be sure the equipment is in safe working condition.
12. Carefully release pressure from components with stored energy.
13. Be sure to depressurize the hydraulic system before performing maintenance operations on it such as removing hydraulic equipment.
14. Check whether line connectors in the hydraulic system are properly tightened.
Before applying hydraulic pressure, check the connections of the hydraulic pressure lines and the condition of the hoses.
15. When checking the hydraulic circuit for pinhole leaks or oil leakage from nozzles, do not use your hands.
Use items such as paper or corrugated cardboard to find leakage points.
Be extremely careful with high-pressure oil as it may pierce your skin, resulting in an injury.
If fluid is injected into the skin it must be surgically removed within a few hours by a doctor familiar with this form of injury or gangrene may result.
16. Use care when checking the rotary knives.
Wrap the rotary knives or wear gloves, and use caution when servicing them.
Only replace rotary knives.
Never straighten or weld them.
17. On multi-rotary knife machines, take care as rotating one rotary knife can cause other rotary knives to rotate.
18. Check the grass catcher frequently for wear or deterioration.
19. Charge batteries in an open well ventilated area, away from spark and flames.
Unplug charger before connecting or disconnecting from battery.
Wear protective clothing and use insulated tools.

20. If the fuel tank has to be drained, do this outdoors.

Storage

1. When machine is to be parked, stored, or left unattended, lower the cutting unit(s) and/or attachment(s) unless a positive mechanical lock is provided.
2. Allow the engine to cool before storing in any enclosure.
3. Only cover the machine with a sheet after hot parts have sufficiently cooled down.
4. Never store the equipment with fuel in the tank inside a building where fumes may reach an open flame or spark.
5. If the engine is provided with a shut-off valve, shut off valve while storing or transporting.
6. Do not store fuel near flames.
7. Swallowing engine coolant can cause injury or death; keep out of reach from children and pets.

Recycle and Waste Disposal Page 2-2

About RecyclePage 2-2

About Waste Disposal Page 2-2

Disposal

Disposal

Recycle and Waste Disposal

About Recycle

Recycling battery etc. is recommended for environmental conservation and economical use of resources.

It may be required by local laws.

About Waste Disposal

Make sure that waste generated when servicing or repairing the machine is disposed of in accordance with local regulations. (e.g. waste oil, antifreeze, rubber products, and wires etc.)

Specifications Page 3-2
 SpecificationsPage 3-2

Sound Pressure Level Page 3-3
 Sound Pressure Level Page 3-3

Sound Power LevelPage 3-3
 Sound Power Level Page 3-3

Vibration Level Page 3-3
 Hand-Arm Vibration Page 3-3
 Whole Body Vibration Page 3-3

Carbon Dioxide (CO2) Emissions Page 3-3

Names of Each Section Page 3-4

Regulation DecalsPage 3-6
 Positions of Regulation Decals Page 3-6
 Description of Regulation Decals Page 3-6

Safety Signs and Instruction Signs ... Page 3-10
 About Safety Signs and Instruction
 SignsPage 3-10
 Positions of Safety Decals and
 Instruction Decals Page 3-10
 Description of Safety Decals and
 Instruction Decals Page 3-11

Operation Decals Page 3-15
 Positions of Operation Decals Page 3-15
 Description of Operation DecalsPage 3-15

Product Overview

Specifications

Specifications

Model		GM1700	
Name		Mid-Mount Rotary Mower	
Dimensions	Total length		255 cm 100.39 in
	Total width		154 cm 60.63 in
	Total height	Roof	197 cm 77.56 in
		Steering wheel	121 cm 47.64 in
Weight	Machine (empty fuel tank) with ROPS	730 kg 1609.35 lb	
Minimum turning radius		298 cm 117.32 in	
Engine	Model		Kubota D1105
	Type		Vertical Water-cooled 4-cycle diesel engine
	Total displacement		1,123 cm ³ (1.123 L) 68.52 cu.in.
	Maximum output		-
	Rated output		18.1 kW (24.6 PS)/2,800 rpm
Fuel tank capacity		Diesel 23.0 dm ³ (23.0 L) Diesel 6.08 U.S.gal.	
Fuel consumption		280 g/kW · h (rated output) 206 g/PS · h (rated output)	
Engine oil capacity		3.0 dm ³ (3.0 L) 0.79 U.S.gal.	
Coolant volume		6.0 dm ³ (6.0 L) 1.59 U.S.gal.	
Hydraulic tank capacity		22.0 dm ³ (22.0 L) 5.81 U.S.gal.	
Transmission oil capacity		0.45 dm ³ (0.45 L) 0.12 U.S.gal.	
Operating width (Mowing width)		See the mower deck's specifications.	
Operating height (Mowing height)		See the mower deck's specifications.	
Number of Blades		See the mower deck's specifications.	
Drive	Traveling		HST (2WD/4WD selectable)
	Mowing		Mechanical
Speed (HST)	Forward	2WD	0 - 16.0 km/h 0 - 9.94 mph
		4WD	0 - 8.0 km/h 0 - 4.97 mph
	Reverse	2WD	0 - 14.0 km/h 0 - 8.70 mph
		4WD	0 - 7.0 km/h 0 - 4.35 mph
Speed (Mechanical)		-	
Efficiency		See the mower deck's specifications.	
Maximum inclination for operation		25 degrees	
Tire size	Front wheel		21 x 11.00 - 10
	Rear wheel		21 x 11.00 - 10
Tire pneumatic pressure	Front wheel		140 kPa (1.4 kgf/cm ²) 20 psi
	Rear wheel		140 kPa (1.4 kgf/cm ²) 20 psi
Battery		80D26R	
Engine plug		-	

The factory default maximum engine rpm is 2,800 rpm.

Sound Pressure Level

Sound Pressure Level

This machine was confirmed to have a continuous A-weighted sound pressure level of 93dB by measuring identical machines in accordance with the procedure specified in ISO 5395-1:2013.

Sound Power Level

Sound Power Level

This machine was confirmed to have a sound power level of 105dB by measuring identical machines in accordance with the procedure specified in ISO5395-1:2013.

Vibration Level

Hand-Arm Vibration

This machine was confirmed not to exceed a vibration level of 2.5 m/s² to hands and arms by measuring identical machines in accordance with the procedure specified in ISO 5395-1:2013.

Uncertainty K = 0.8 m/s²

Whole Body Vibration

This machine was confirmed not to exceed a vibration level of 0.5 m/s² to the whole body by measuring identical machines in accordance with the procedure specified in ISO 5395-1:2013.

Uncertainty K = 0.2 m/s²

Carbon Dioxide (CO₂) Emissions

For the CO₂ value on the engine of this machine, refer to the engine's owner's manual.

Product Overview

Names of Each Section

Overall view A

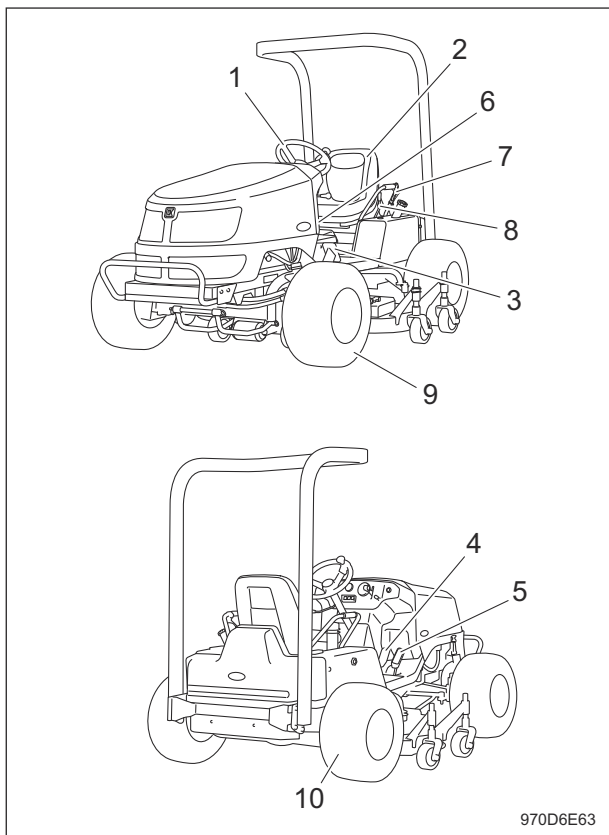

Names of Each Section_001

1	Steering wheel
2	Seat
3	Brake pedal
4	Forward pedal
5	Reverse pedal
6	Parking brake lever
7	Clutch lever
8	2WD/4WD selector lever
9	Front wheel
10	Rear wheel

Overall view B

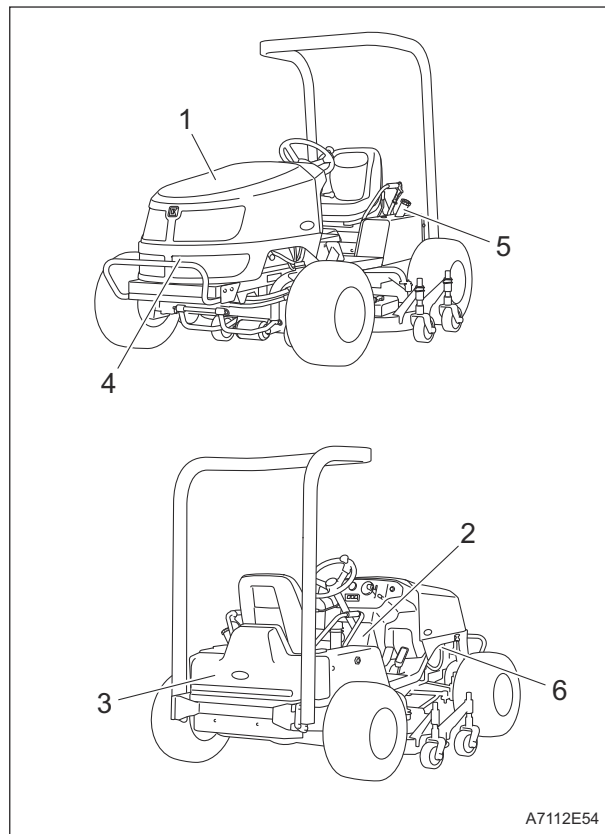

Names of Each Section_002

1	Hood
2	Center cover
3	Rear cover
4	Battery
5	Fuel tank
6	Fuel filter

Product Overview

Overall view C

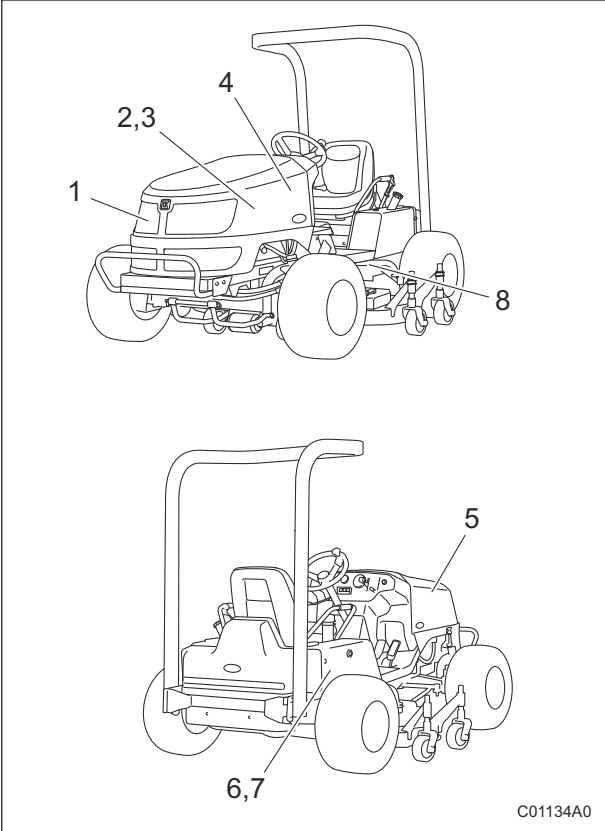

Names of Each Section_003

1	Radiator
2	Engine
3	Engine oil filter
4	Reserve tank
5	Air cleaner
6	Hydraulic tank
7	Air breather
8	Hydraulic oil line filter

Operation panel

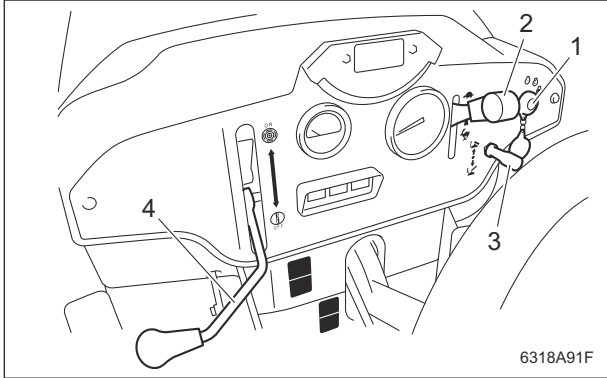

Names of Each Section_004

1	Key switch
2	Throttle lever
3	Mower deck up/down switch
4	Knife rotation lever

Product Overview

Product Overview

Regulation Decals

Positions of Regulation Decals

Main vehicle

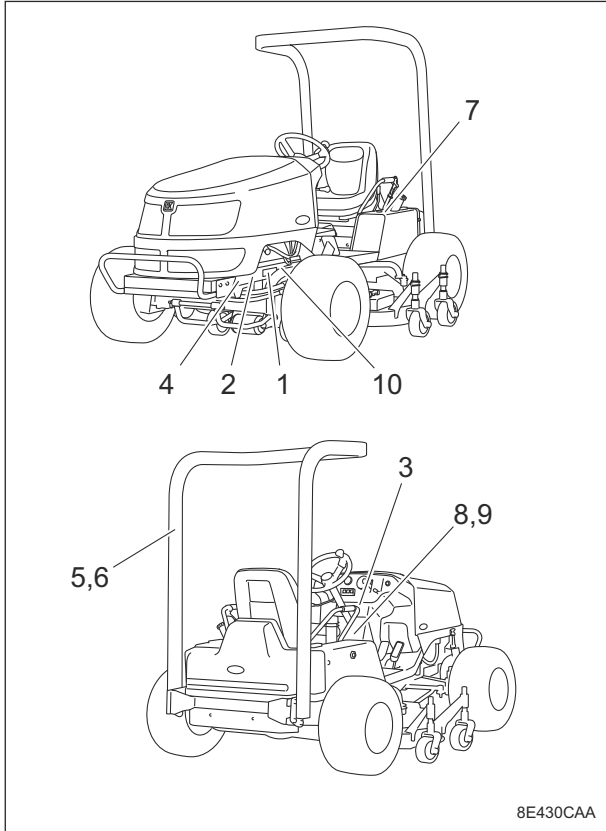

Positions of Regulation Decals_001

1	Serial number plate
2	Specification decal
3	Noise emission decal
4	Year of manufacture decal
5	ROPS compliance decal
6	ROPS caution decal
7	Indicating diesel fuel decal
8	California Proposition 65 decal (riding type)
9	Spark arrester warning decal
10	ISED compliance decal (#21585-)

Battery

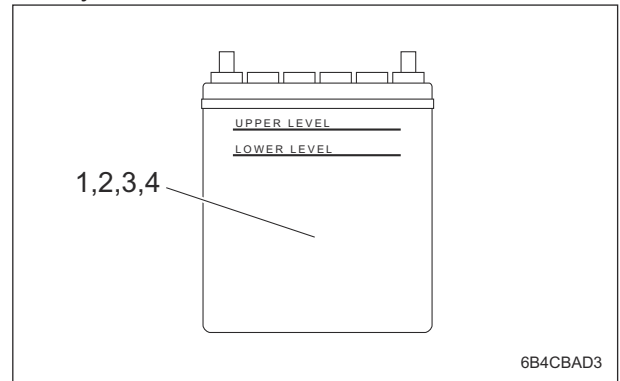

Positions of Regulation Decals_002

1	Battery capacity decal
2	EU battery regulation decal
3	Recycle decal
4	Battery danger decal

Description of Regulation Decals

Serial Number Plate

The serial number plate indicates the model and serial number of the machine.

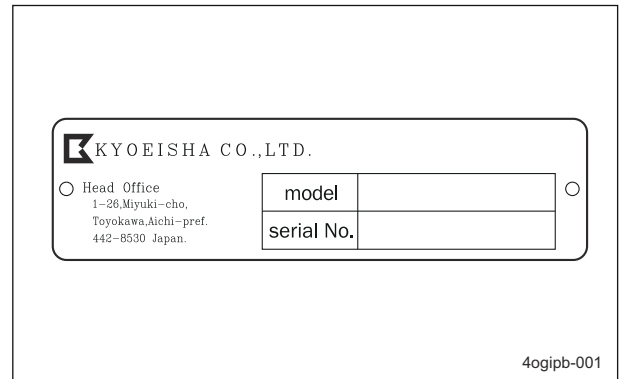

Serial Number Plate_001

Specification Decal

(For EU)

The Specification decal indicates the model and weight, etc.

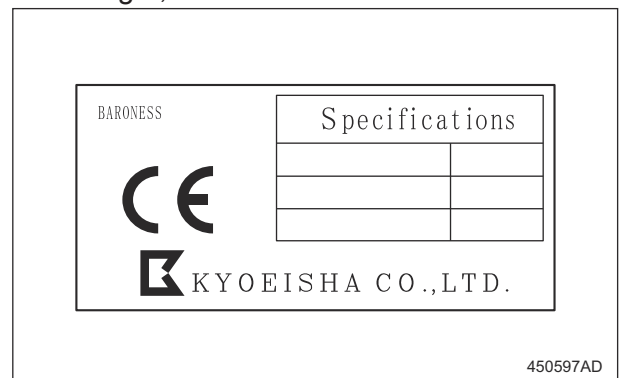

Specification Decal_001

Product Overview

Noise Emission Decal

(For EU)
The noise emission decal indicates the sound power level determined by measuring identical machines in accordance with the procedure specified in the regulations of EU.

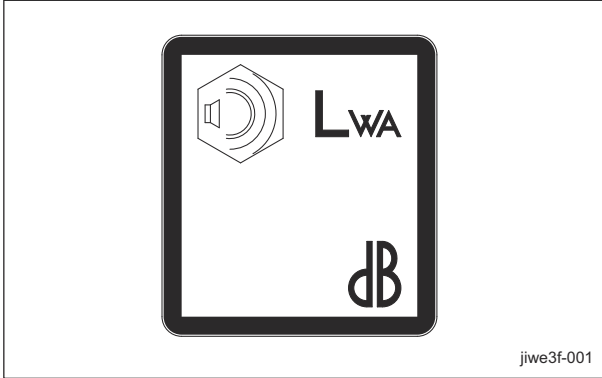

Noise Emission Decal_001

ROPS Caution Decal

ROPS caution decal describes the following caution messages.

- Replace damaged ROPS.
- Do not repair or revise.

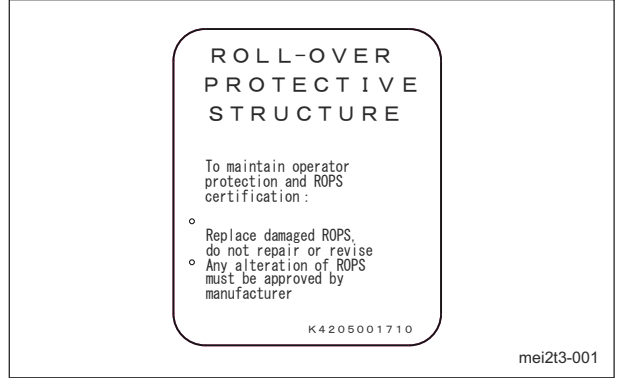

ROPS Caution Decal_001

Year of Manufacture Decal

(For EU)
The year of manufacture decal indicates the year when this machine was manufactured.

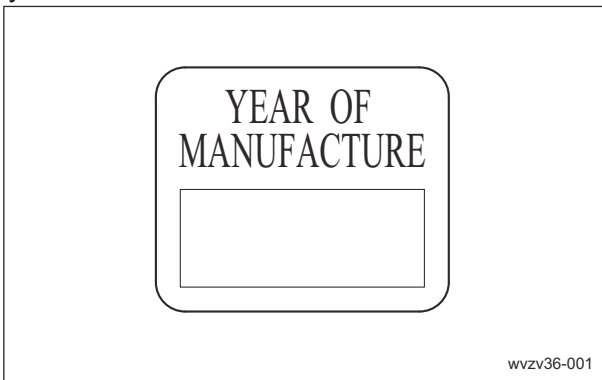

Year of Manufacture Decal_001

Indicating Diesel Fuel Decal

(for USA)
It indicates the fuel to be used.
Use low sulfur or ultra-low sulfur diesel fuel (sulfur-free diesel fuel).

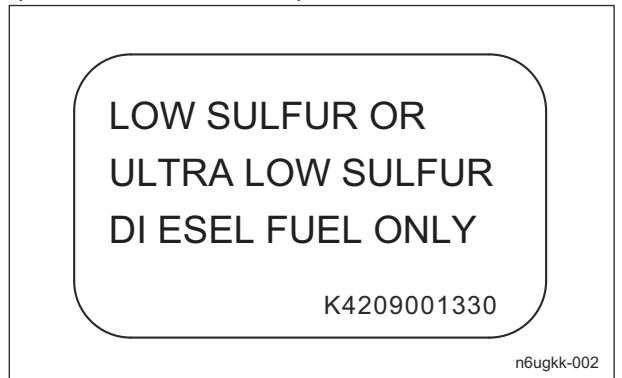

Indicating Diesel Fuel Decal_001

ROPS Compliance Decal

The ROPS compliance decal indicates the manufacturer, model, etc., in accordance with International Standard ISO 21299:2009.

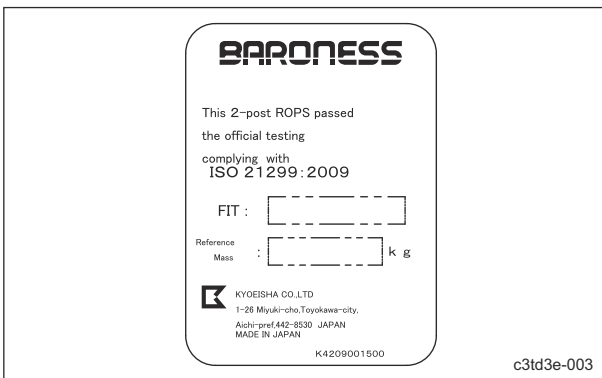

ROPS Compliance Decal_001

Product Overview

California Proposition 65 Decal (Riding Type)

(For the State of California, USA)
 California Proposition 65 decal describes the warning messages as required by California Proposition 65.

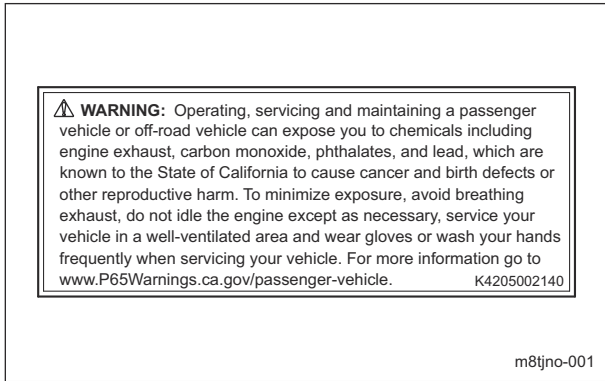

California Proposition 65 Decal (Riding Type)_001

ISED Compliance Decal

(For Canada)
 The ISED compliance decal indicates that the product marketed in Canada meets Canadian standard.

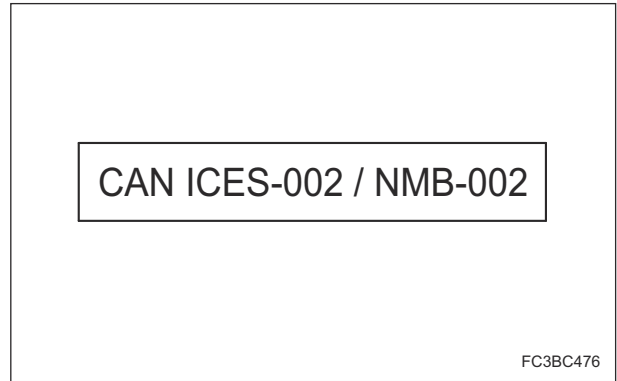

ISED Compliance Decal_001

Spark Arrester Warning Decal

(For the State of California, USA)
 Spark arrester warning decal describes the warning messages as required by California Public Resources Code.

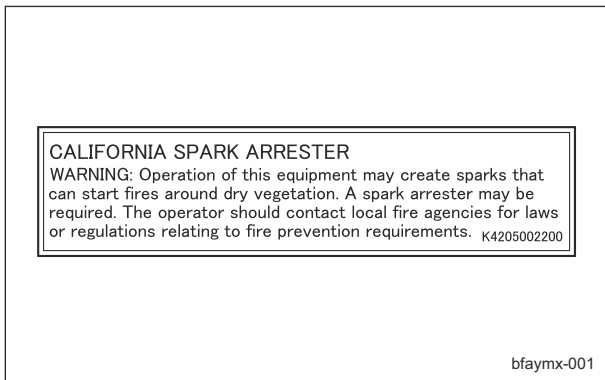

Spark Arrester Warning Decal_001

Battery Capacity Decal

(For EU)
 The battery capacity decal indicates the capacity by 20HR and CCA.

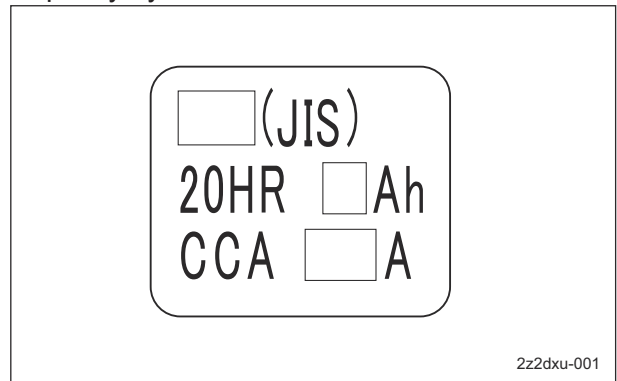

Battery Capacity Decal_001

EU Battery Regulation Decal

(For EU)

The EU battery regulation decal indicates compliance with the EU battery regulation.

1. The following information about the battery manufacturing company is written in the decal.
 - Company name
 - Address
 - Website URL
2. You can scan the QR code with your smartphone to access the corresponding battery information.
3. CE mark indicates that the battery installed in a machine sold in the EU nations complies with the EU requirements.

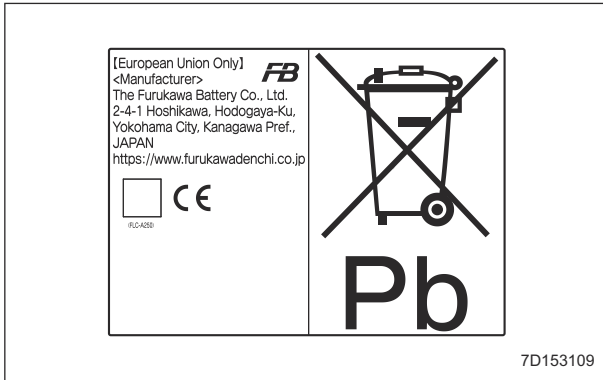

EU Battery Regulation Decal_001

Recycle Decal

Recycle Decal illustrates Recycle Mark in accordance with local regulation.

(For EU)

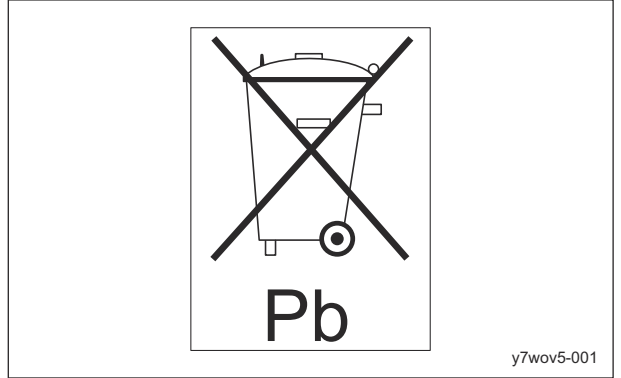

Recycle Decal_001

(For USA)



Recycle Decal_002

Battery Danger Decal

(For USA)

Battery Danger Decal describes handling precautions for battery.

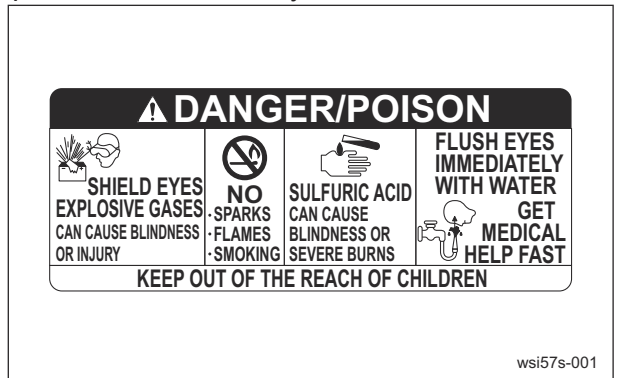

Battery Danger Decal_001

Product Overview

Safety Signs and Instruction Signs

About Safety Signs and Instruction Signs

Important

Safety decals and instruction decals are attached to this product. Make sure that they are preserved in their entirety. If they are damaged, become dirty, or peel off, replace them with new ones.

Part numbers for decals that need to be replaced are listed in the parts catalog. Order them from a Baroness dealer or Kyoeshia.

Positions of Safety Decals and Instruction Decals

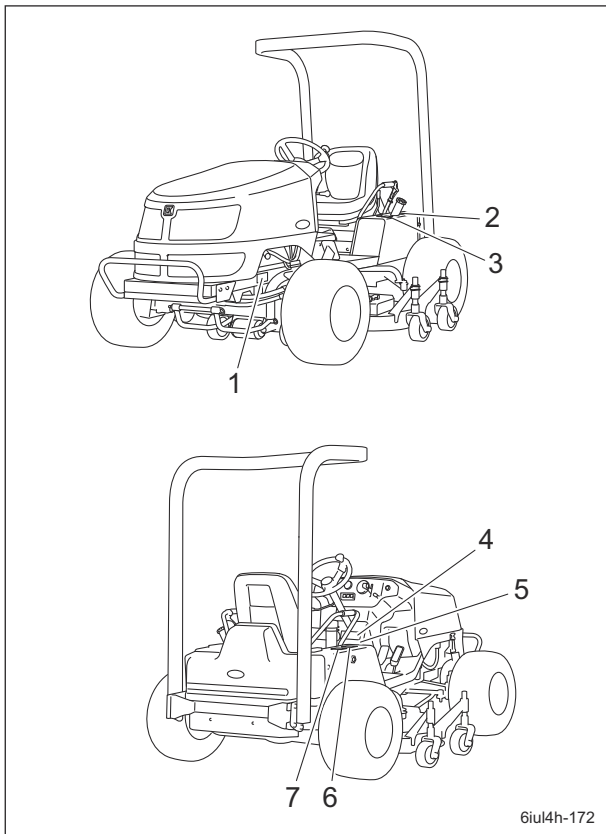

Positions of Safety Decals and Instruction Decals_001

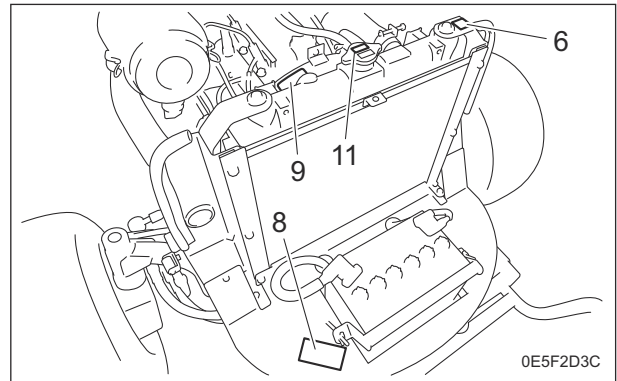

Positions of Safety Decals and Instruction Decals_002

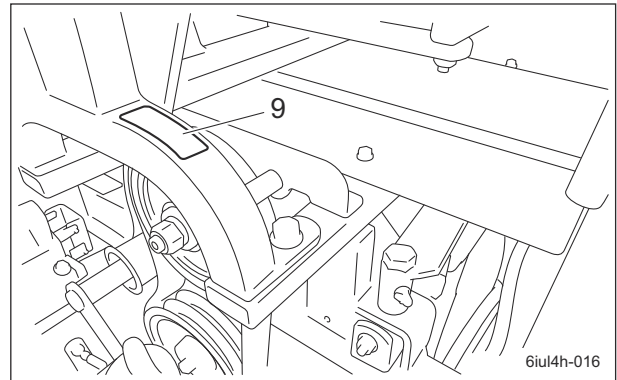

Positions of Safety Decals and Instruction Decals_003

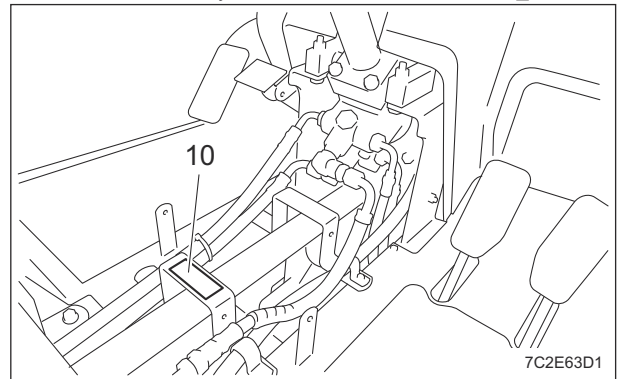

Positions of Safety Decals and Instruction Decals_004

1	Caution to hot parts decal
2	Diesel fuel filler port decal
3	Fire prohibited decal
4	Handling caution decal
5	Caution slope decal
6	Caution for high temperatures decal
7	Hydraulic oil decal
8	Caution for getting caught decal
9	Caution for getting entangled decal
10	PTO caution decal
11	Caution for spouting coolant decal

Description of Safety Decals and Instruction Decals

Caution to Hot Parts Decal

K4205001540
Decal for caution to hot parts



High temperature - Do not touch. Otherwise, you will get burned.



xekv4l-001

Caution to Hot Parts Decal_001

Diesel Fuel Filler Port Decal

K4209001000
DECAL, DIESEL OIL FILLER PORT
Use diesel fuel.

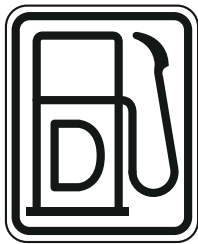

xmitt2-001

Diesel Fuel Filler Port Decal_001

Fire Prohibited Decal

K4205001940
Decal, fire prohibited

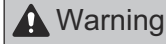

Keep away from fire.



r653fo-001

Fire Prohibited Decal_001

Product Overview

Handling Caution Decal

K4205002010
DECAL, CAUTION HANDLING

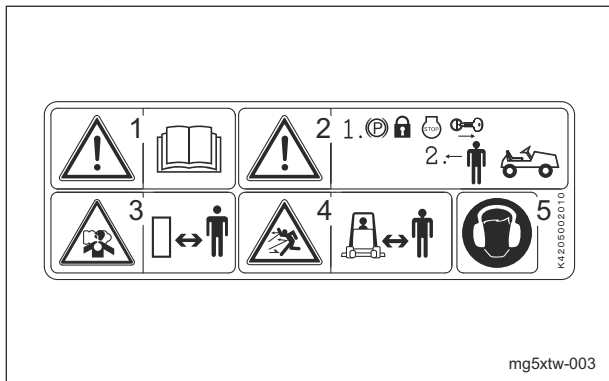

Handling Caution Decal_001

1.



Read the Owner's Operating Manual.

2.



Apply the parking brake, stop the engine, and then remove the ignition key before leaving the machine.

3.

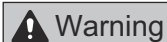

Be careful of exhaust emissions.

4.

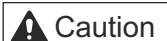

Thrown objects - Be sure that people around the machine keep a safe distance away.

5.

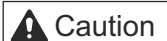

Caution for noise emission

Caution Slope Decal

K4205002110
DECAL, ATTENTION AT SLOPE

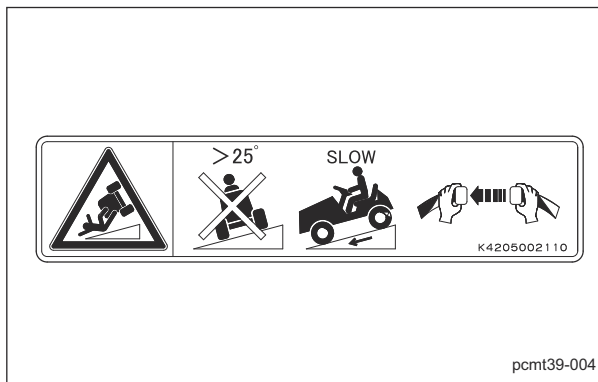
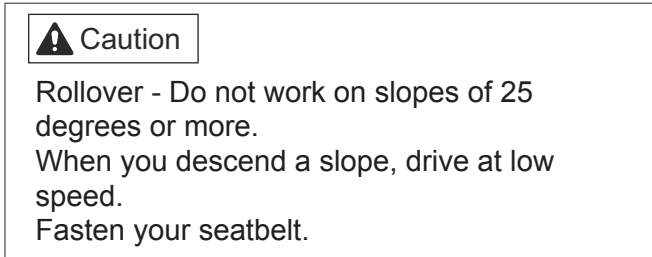

Caution Slope Decal_001

Caution for High Temperatures Decal

K4205001920
Decal, caution for high temperatures

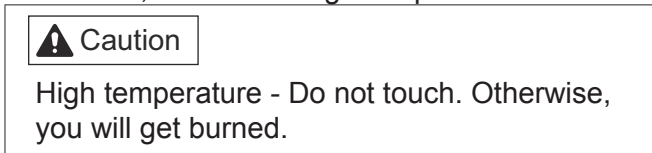

Caution for High Temperatures Decal_001

Product Overview

Hydraulic Oil Decal

K4209000980
DECAL, HYDRAULIC OIL
Read the Owner's Operating Manual.

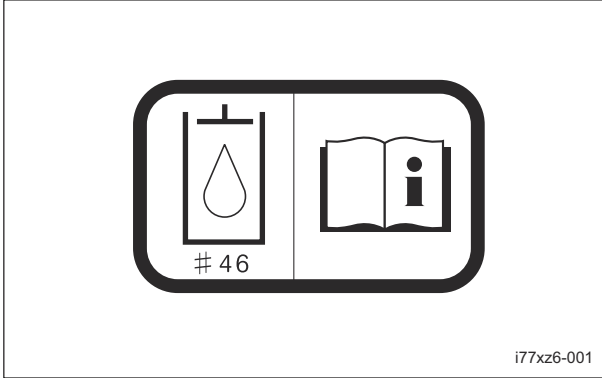

Hydraulic Oil Decal_001

Caution for Getting Caught Decal

K4205001580
DECAL, CAUTION TO GET CAUGHT

Caution

May get pinched - There is a risk of being pinched.

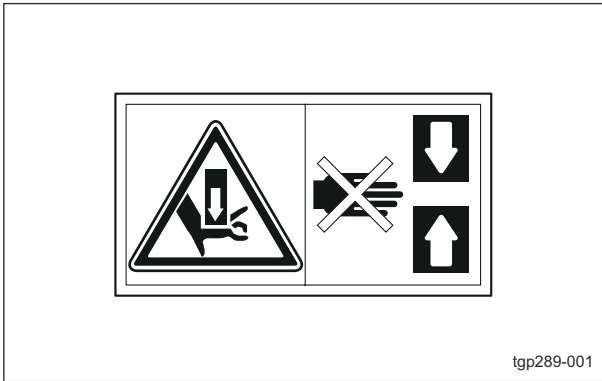

Caution for Getting Caught Decal_001

Caution for Getting Entangled Decal

K4205001910
DECAL, CAUTION NOT TO GET CAUGHT
IN

Warning

Watch for rotating parts - Keep your hands away from the belts while the engine is running.

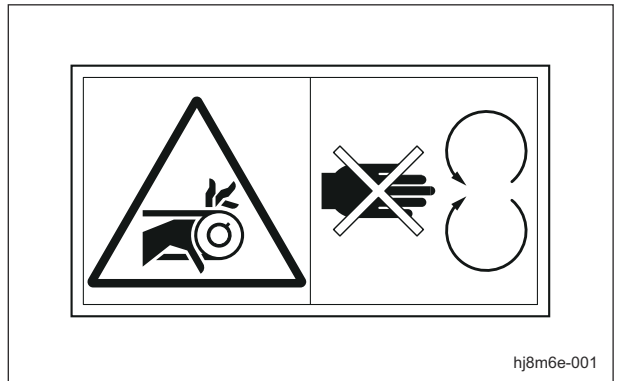

Caution for Getting Entangled Decal_001

PTO Caution Decal

K4205002000
Decal, caution PTO

Warning

Watch for rotating parts - Keep your hands away from the joints while the engine is running.

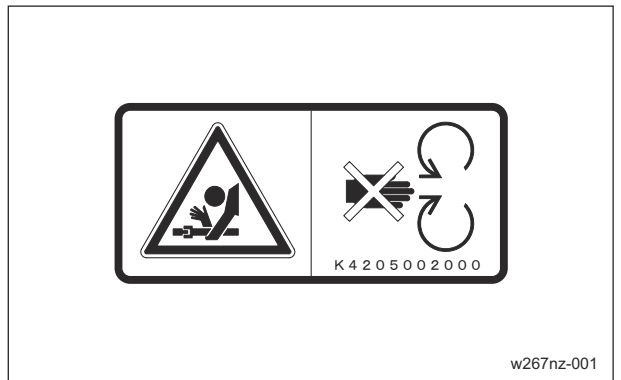

PTO Caution Decal_001

Product Overview

Caution for Spouting Coolant Decal

K4205001970

Decal, caution for spouting coolant

 Caution

Caution for spouting coolant - Do not open while hot.

High temperature - Do not touch. Otherwise, you will get burned.

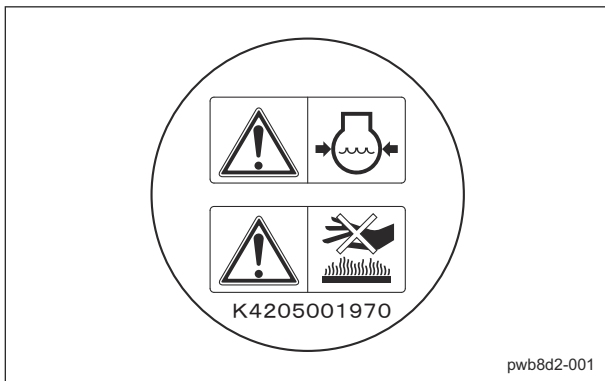

Caution for Spouting Coolant Decal_001

Operation Decals

Positions of Operation Decals

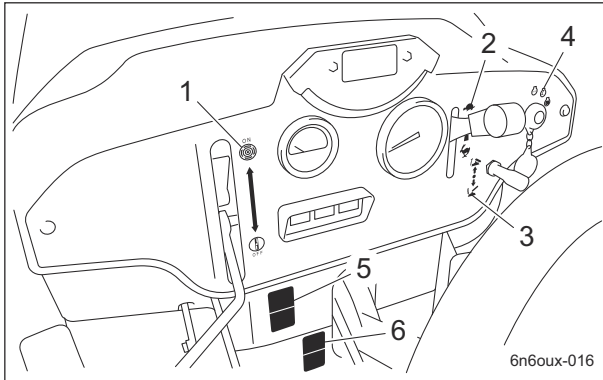

Positions of Operation Decals_001

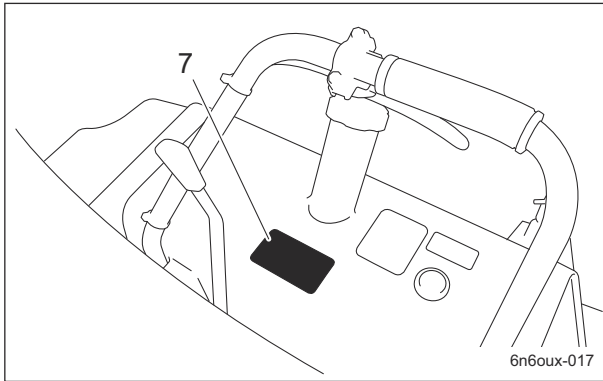

Positions of Operation Decals_002

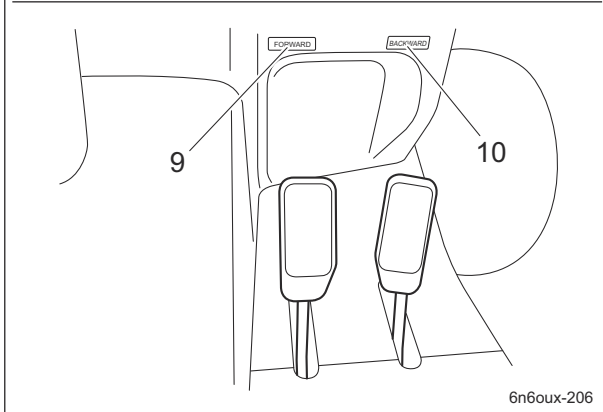
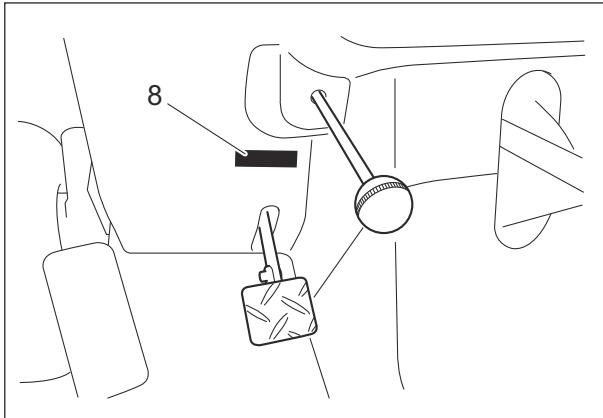

Positions of Operation Decals_003

1	Knife rotation mark
2	Engine rotation mark
3	Mower deck up/down mark
4	Key switch decal
5	Parking brake decal
6	Tilt steering decal
7	2WD - 4WD changeover decal
8	BRAKE decal
9	FORWARD decal
10	BACKWARD decal

Description of Operation Decals

Knife Rotation Mark

Knife rotation mark

It illustrates Rotation/Stop of the rotary knife.

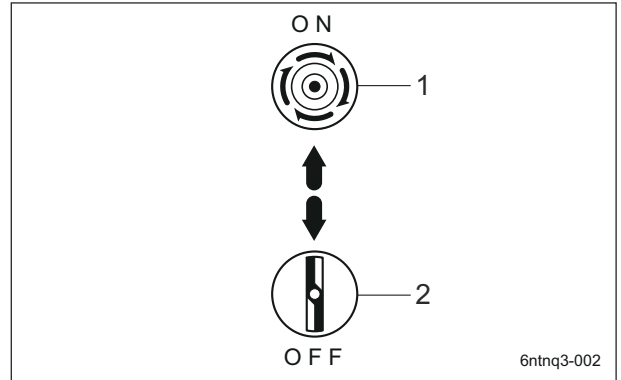

Knife Rotation Mark_001

1	Rotation
2	Stop

Engine Rotation Mark

Engine rotation mark

This indicates high/low speed of the engine rotation.

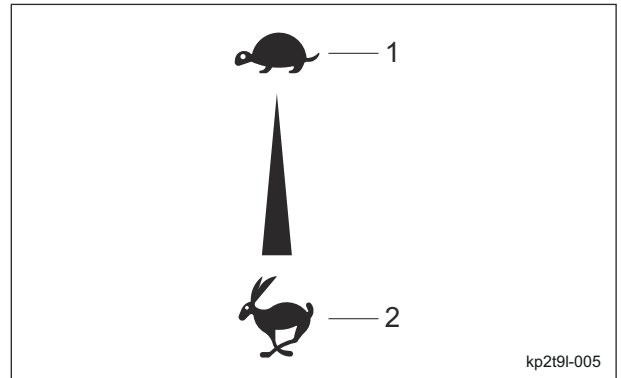

Engine Rotation Mark_001

1	Low speed
2	High speed

Product Overview

Mower Deck Up/Down Mark

Mower deck up/down mark
This indicates the Up/Down positions of the mower deck.

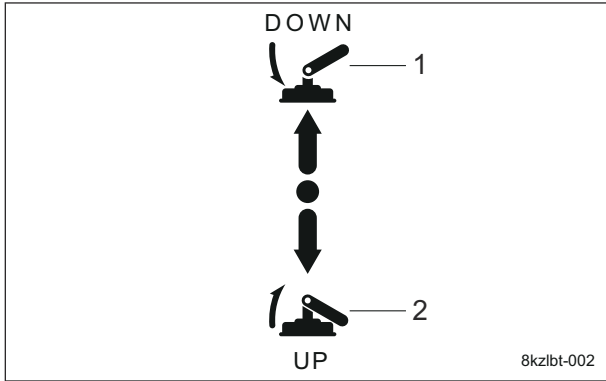

Mower Deck Up/Down Mark_001

1	Down
2	Up

Parking Brake Decal

K4203001340
Parking brake decal
This shows how to lock and release the parking brake.

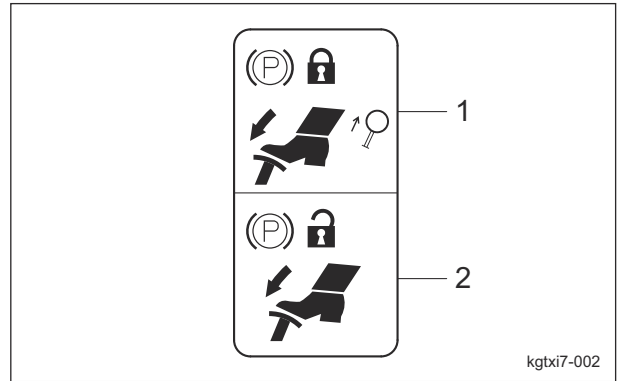

Parking Brake Decal_001

1	Lock
2	Release

Key Switch Mark

Key switch mark
This indicates the key switch positions.

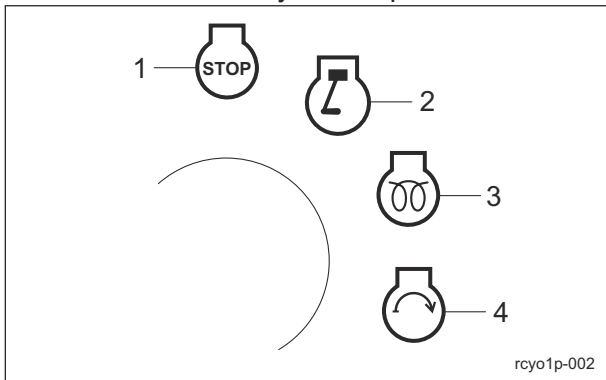

Key Switch Mark_001

1	OFF
2	ON
3	GLOW
4	START

Tilt Steering Decal

K4203001500
Tilt steering decal
This illustrates the tilt directions of the steering wheel and the locked/free positions.

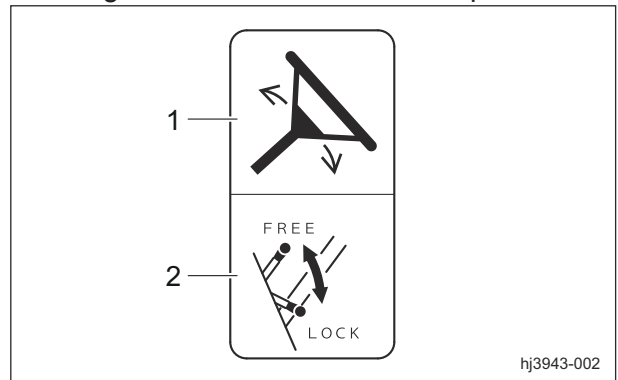

Tilt Steering Decal_001

Product Overview

2WD - 4WD Changeover Decal

K4203001510
DECAL, LEVER CHANGING 2WD / 4WD
This indicates 2WD/4WD changeover.

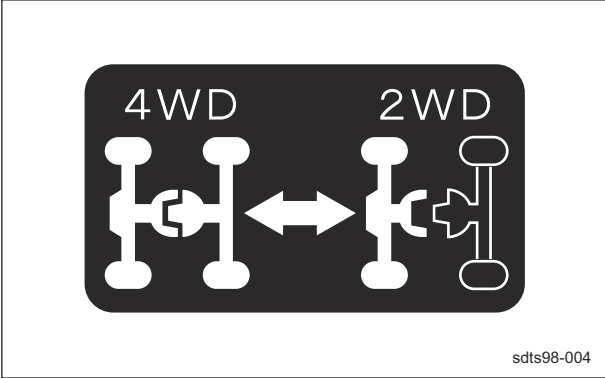

2WD - 4WD Changeover Decal_001

BACKWARD Decal

K4203001440
Decal, BACKWARD
This indicates backward travel.

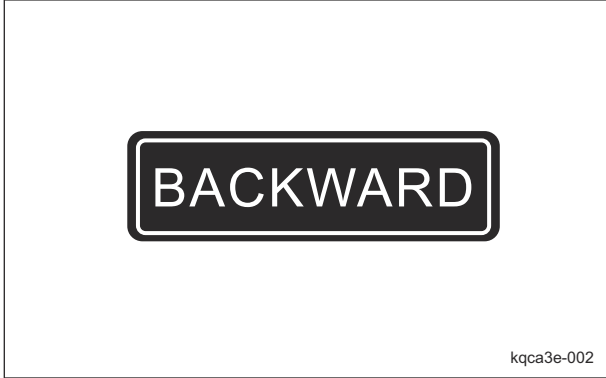

BACKWARD Decal_001

BRAKE Decal

K4203001450
Decal, BRAKE
This indicates brake.



BRAKE Decal_001

FORWARD Decal

K4203001430
Decal, FORWARD
This indicates forward travel.



FORWARD Decal_001

Product Overview

Description of Functions

- Key SwitchPage 4-2**
- Throttle Lever Page 4-2**
- Mower Deck Up/Down SwitchPage 4-2**
- Knife Rotation LeverPage 4-3**
- 2WD/4WD Selector Lever Page 4-3**
- Traveling Pedal Page 4-3**
- Brake Pedal Page 4-4**
- Parking Brake Lever Page 4-4**
- Instruments on the Operation PanelPage 4-4**
 - Tachometer/Hour Meter Page 4-4
 - Water Temperature Gauge Page 4-5
 - Pilot Lamps Page 4-5
 - Angle Meter Page 4-6
- Safety Mechanisms Page 4-6**
- Warning BuzzerPage 4-6**

Description of Functions

Key Switch

The key switch is a lock for inserting the ignition key.

This is used for starting, running or stopping the engine by turning the ignition key to change the key switch position.

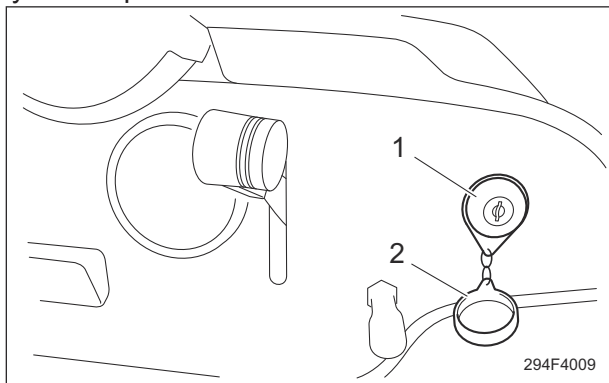

Key Switch_001

1	Key switch
2	Cap

Throttle Lever

The throttle lever is located in the operation panel and enables you to adjust the engine rpm. Move the throttle lever toward the "High speed" position to increase the engine rpm, and toward the "Low speed" position to reduce the rpm.

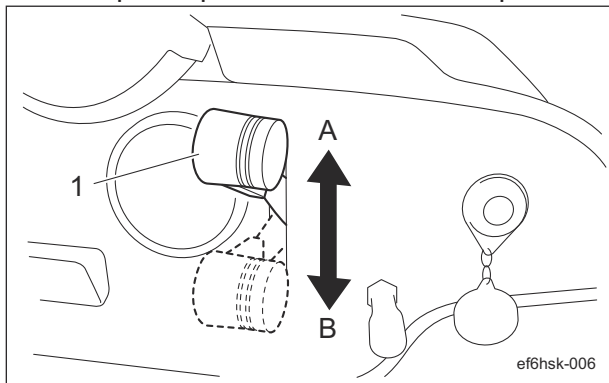

Throttle Lever_001

1	Throttle lever
A	Low speed
B	High speed

Mower Deck Up/Down Switch

⚠ Caution

Before raising or lowering the mower decks, make sure that there are no people around the machine.

⚠ Caution

When traveling, be sure to stop the knives and raise the mower decks.

The mower deck up/down switch is located in the operation panel and raises or lowers the mower decks.

When the switch is shifted to the "DOWN" position, the mower decks are lowered. When the switch is shifted to the "UP" position, the mower decks are raised.

Release the switch to return it to the neutral position.

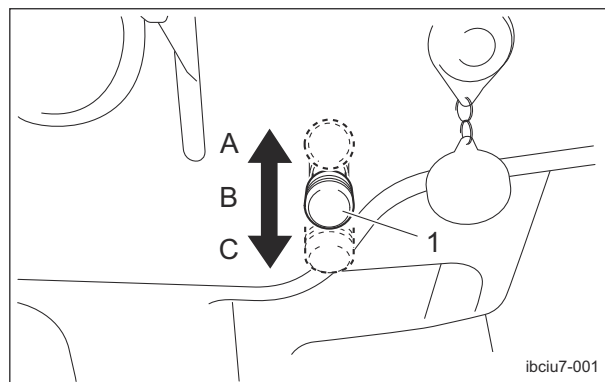

Mower Deck Up/Down Switch_001

1	Mower deck up/down switch
A	UP
B	Neutral
C	DOWN

Description of Functions

Knife Rotation Lever

Caution

Just before you start cutting work, set the knife rotation lever to the "Rotation" position. At all other times, make sure it is set to the "Stop" position.

Caution

When traveling, be sure to stop the knives and raise the mower decks.

The knife rotation lever is located in the operation panel and controls the rotation of the rotary knives.

When the knife rotation lever is set to the "Rotation" position, all rotary knives rotate. When the knife rotation lever is set to the "Stop" position, all rotary knives stop.

When the mower decks are raised, the rotary knives rotate if the lever is set to the "Rotation" position.

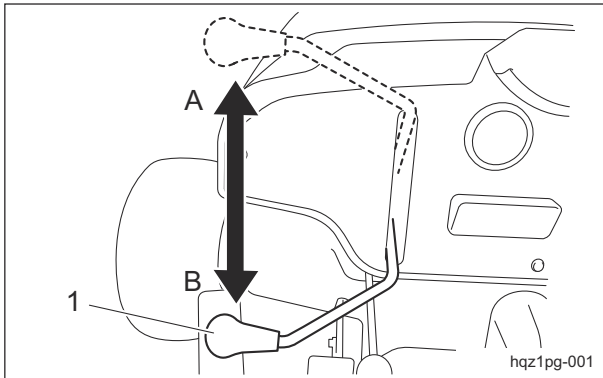

Knife Rotation Lever_001

1	Knife rotation lever
A	Rotation
B	Stop

2WD/4WD Selector Lever

Caution

When working on a slope, be sure to use the machine in 4WD.

The 2WD/4WD selector lever is located to the left of the driver's seat.

When the 2WD/4WD selector lever is set to the "2WD" position, the machine will be in two-wheel drive (rear-wheel drive). When it is set to the "4WD" position, the machine will be in four-wheel drive.

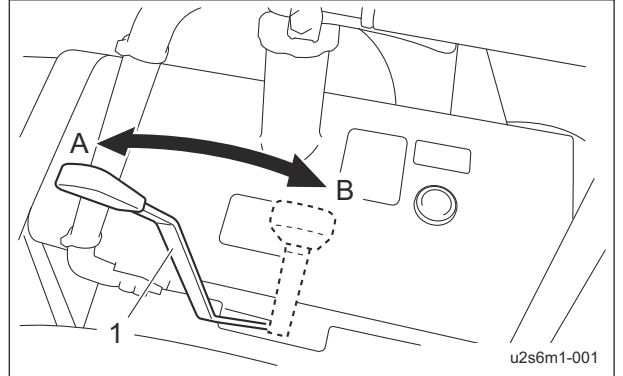

2WD/4WD Selector Lever_001

1	2WD/4WD selector lever
A	4WD
B	2WD

Traveling Pedal

Caution

When the machine is traveling at a high speed, it will not stop immediately after you take your foot off the traveling pedal. If necessary, also use the brake.

The traveling pedals are located in the right foot area and control forward and reverse operation of the machine.

When the forward pedal (inside) is depressed, the machine travels forward. When the reverse pedal (outside) is depressed, the machine travels in reverse.

The speed changes in accordance with how much the pedal is depressed.

When you take your foot off the pedal, the machine stops automatically.

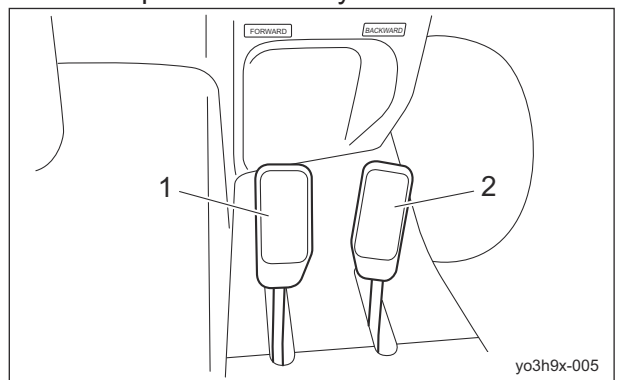

Traveling Pedal_001

Description of Functions

Description of Functions

1	Forward pedal
2	Reverse pedal

Brake Pedal

The brake pedal is located in the left foot area. To stop the machine, depress the brake pedal all the way firmly.

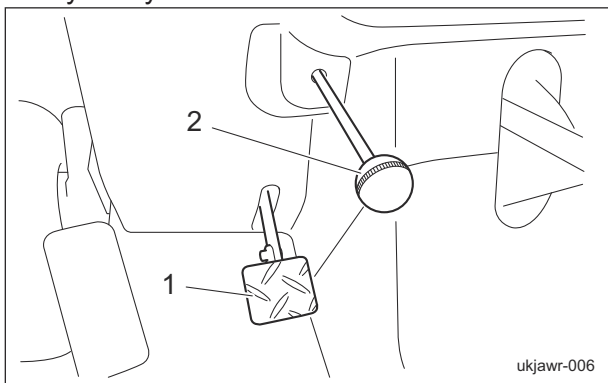

Brake Pedal_001

1	Brake pedal
2	Parking brake lever

Parking Brake Lever

⚠ Caution

Never park the machine on a slope.

Important

Be sure to release the parking brake before driving. It will result in the brakes or hydraulic system malfunction.

The parking brake lever is located to the left of the front cover. To park the machine, depress the brake pedal and pull the parking brake lever completely. To release the parking brake, depress the brake pedals.

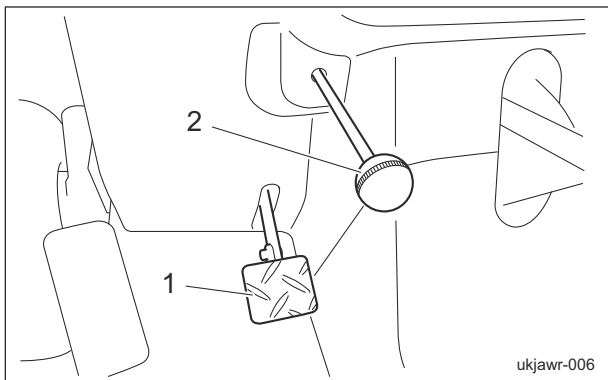

Parking Brake Lever_001

1	Brake pedal
2	Parking brake lever

Instruments on the Operation Panel

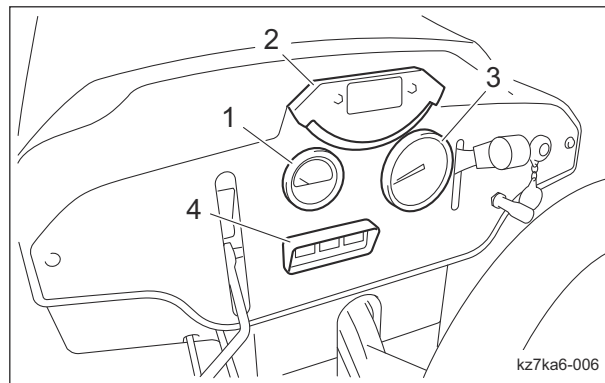

Instruments on the Operation Panel_001

1	Water temperature gauge
2	Angle meter
3	Tachometer/Hour meter
4	Pilot lamps (charge lamp, thermo-start lamp, oil pressure lamp)

Tachometer/Hour Meter

The tachometer and hour meter are located in the operation panel. The tachometer indicates the engine rpm. The hour meter indicates total operation time of the engine. Every six minutes of engine operation will increase the number at the first digit (black number on a white background) by one. Every one hour of engine operation will increase the number at the next digit (white number on a black background) by one.

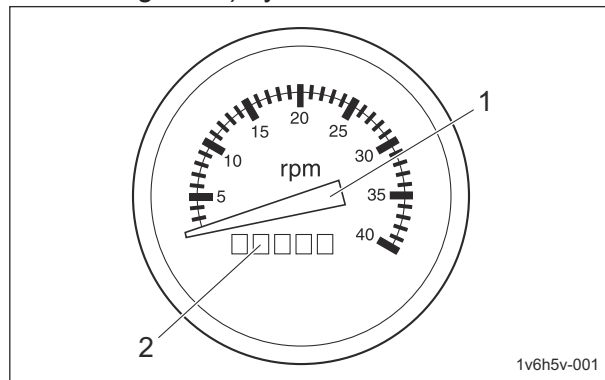

Tachometer/Hour Meter_001

1	Tachometer
2	Hour meter

Description of Functions

Water Temperature Gauge

This instrument indicates the water temperature inside the engine.
 If the water temperature gauge indicates a level close to "H" during operation, the machine is overheated.
 Remove the load from the engine, idle the machine for five minutes, stop the engine, and then inspect the machine and perform any necessary maintenance.

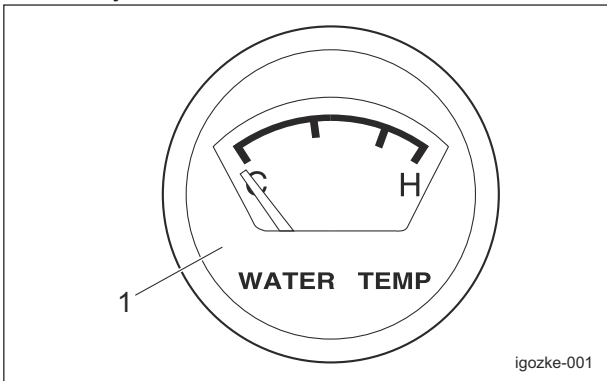

Water Temperature Gauge_001

1	Water temperature gauge
---	-------------------------

Thermo-Start Lamp

The thermo-start lamp is the middle pilot lamp located in the operation panel.
 When the ignition key is set to the "GLOW" position, it illuminates as the glow plug generates heat.
 Illumination of the thermo-start lamp is controlled by the glow lamp timer, and the lamp is turned off after a specified amount of time passes.
 The duration of illumination indicates an approximate period of time required for warm-up, and has been fixed at five seconds.

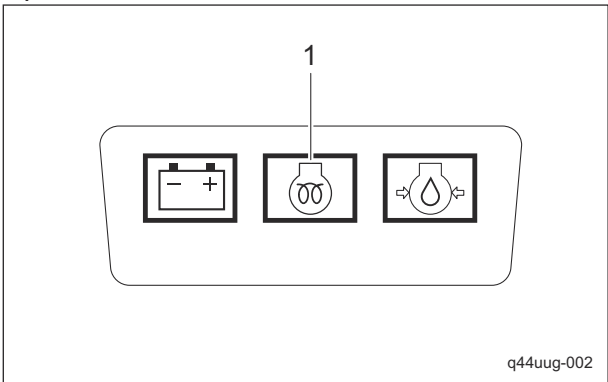

Thermo-Start Lamp_001

1	Thermo-start lamp
---	-------------------

Pilot Lamps

Charge Lamp

The charge lamp is the left pilot lamp located in the operation panel.
 It turns on when the ignition key is set to the "ON" position before the engine starts. It turns off when the engine starts and the alternator starts operating properly.
 If this lamp illuminates while you are operating the machine, stop the engine immediately, and then inspect the machine and perform any necessary maintenance.

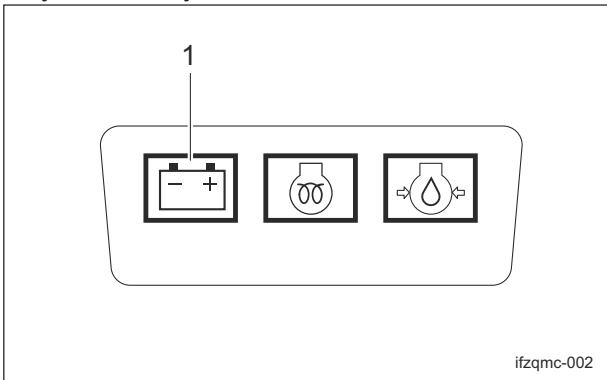

Charge Lamp_001

1	Charge lamp
---	-------------

Oil Pressure Lamp

The oil pressure lamp is the right pilot lamp located in the operation panel.
 It turns on when the ignition key is set to the "ON" position before the engine starts. It turns off when the engine starts and engine oil pressure is generated properly.
 If this lamp illuminates while you are operating the machine, stop the engine immediately, and then inspect the machine and perform any necessary maintenance.

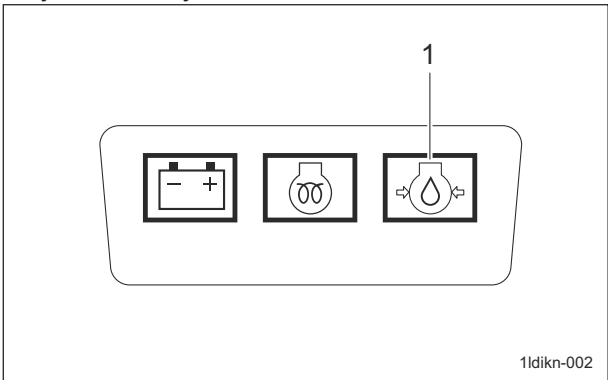

Oil Pressure Lamp_001

1	Oil pressure lamp
---	-------------------

Description of Functions

Angle Meter

The angle meter is located in the operation panel.

This instrument indicates the angle of the machine position.

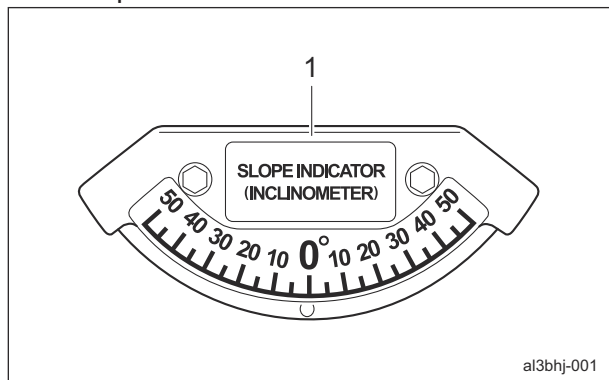

Angle Meter_001

1	Angle meter
---	-------------

Warning Buzzer

1. Overheat Warning Buzzer

⚠ Caution

When the buzzer (intermittent tone) sounds, be sure to stop operation since the engine is overheated.

Do not stop the engine without idling. Allow the engine to cool down, first.

Keep the engine idling for about 5 minutes before stopping.

Remove dust that is jamming in the radiator, air cleaner, and etc.

If water temperature inside the engine exceeds 105 °C (221 °F), a buzzer will sound. (intermittent tone)

Remove the load from the engine, idle the machine for five minutes, stop the engine, and then inspect the machine and perform any necessary maintenance.

Safety Mechanisms

This machine features a safety device for starting/stopping the engine.

- As for starting the engine, the safety device prevents the engine from starting unless it meets each of the following four conditions.
 - An operator is sitting on the seat.
 - The parking brake is applied.
 - The knife rotation lever is set to the "Stop" position.
 - The traveling pedal is set to the neutral position.
- The safety device will be activated and will stop the engine under any of the following conditions:
 - The operator leaves the seat without applying the parking brake.
 - The operator leaves the seat while the knife is rotating.
 - The traveling pedal is operated while the parking brake is applied and the operator is away from the seat.

Handling Instructions

Pre-installation Adjustments Page 5-2

- Installation of Attachments Page 5-2
- Installation of Universal Joint Page 5-2

Operations Before Service Page 5-2

- Opening and Closing of Hood Page 5-2
- Removing and Installing of Rear Cover Page 5-3
- Removing and Installing of Center Cover Page 5-3
- Removing and Installing of Seatback Cover Page 5-4
- Removing and Installing of Underseat Cover Page 5-4

Inspection and Cleaning Page 5-5

- Hood Page 5-5
- Radiator Page 5-6
- Coolant Page 5-6
- Hydraulic Oil Page 5-7
- Hydraulic Hoses Page 5-9
- Air Cleaner Page 5-9
- Battery Page 5-10
- Electrical Wiring Page 5-11
- Tire Page 5-12
- Brake Page 5-12
- Clutch Page 5-12
- Belt Page 5-12
- Wire Page 5-12
- Around The Engine Page 5-13
- Engine Oil Page 5-13
- Fuel Page 5-14
- Fuel Filter Page 5-15
- Liquid Leakage Page 5-15
- Bolts and Nuts Page 5-15

Adjustment before Work Page 5-16

- Adjustment of Steering Wheel Position Page 5-16
- Adjustment of Seat Position Page 5-16

Start/Stop of Engine Page 5-17

- Procedure to Start Engine Page 5-17

- Procedure to Stop Engine Page 5-18

Parking and Stopping Page 5-18

- Procedure to Leave The Machine Page 5-18

Move Page 5-18

- Traveling Procedure Page 5-18

Cutting Work Page 5-19

- Cutting Operation Page 5-19

Transporting Page 5-19

- Transporting Procedure Page 5-19

Handling Instructions

Handling Instructions

Pre-installation Adjustments

Installation of Attachments

For details on installing the attachment, please refer to the separate attachment's Operating Manual.

Installation of Universal Joint

Important

Check the alignment point of the splines before installing (inserting) the universal joint.

1. Check the alignment point of the splines for connecting the universal joint.

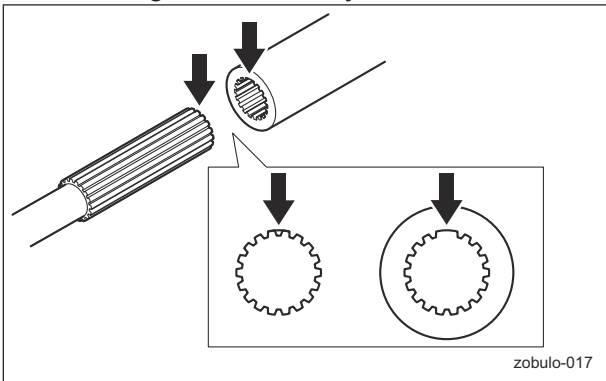

Installation of Universal Joint_001

2. Align the holes of the universal joint and gearbox, and then install it with the pin, washer and cotter pin.

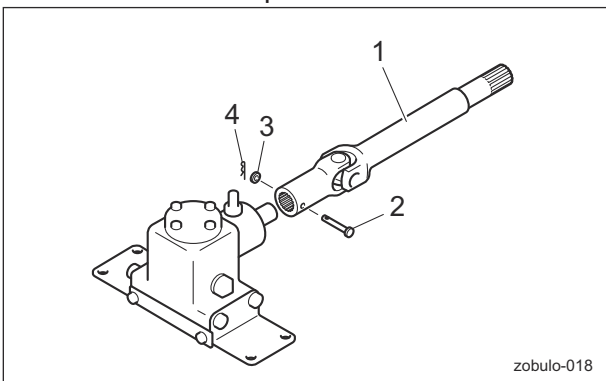

Installation of Universal Joint_002

1	Universal joint
2	Pin
3	Washer
4	Cotter pin

Note:

For removing the universal joint, reverse the installation procedure.

Operations Before Service

The following sections describe the preparatory works required before performing the services including inspection, adjustment, cleaning, maintenance and repair.

Opening and Closing of Hood

Caution

Do not open the hood in strong winds.

Caution

Be careful not to pinch your fingers when you open or close the hood.

1. Remove the bolt and nut.
2. Unlock the rubber catch, and then lift up the hood.

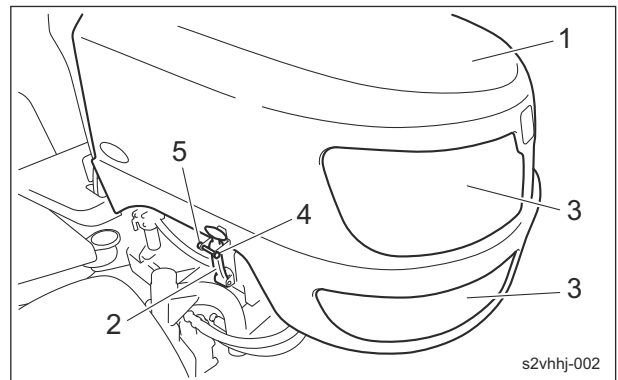

Opening and Closing of Hood_001

1	Hood
2	Rubber catch
3	Intake
4	Bolt
5	Nut

Handling Instructions

- Lift the hood and check that the hood support rod is secured effectively. Make sure that the hood will not close, and then remove your hands.

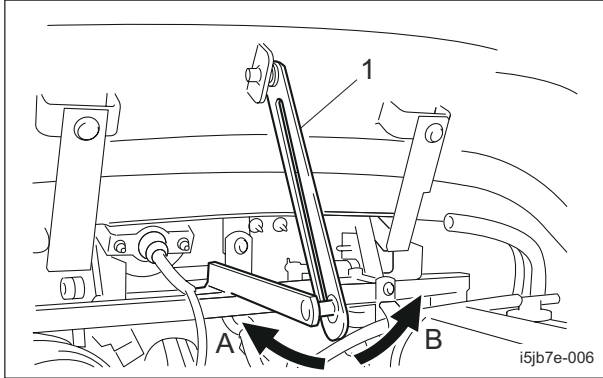

Opening and Closing of Hood_002

1	Hood support rod
A	Secure
B	Released

- To close the hood, release the hood support rod, and then lower the hood slowly.
- Lock the rubber catch securely.
- Install the bolt and nut.

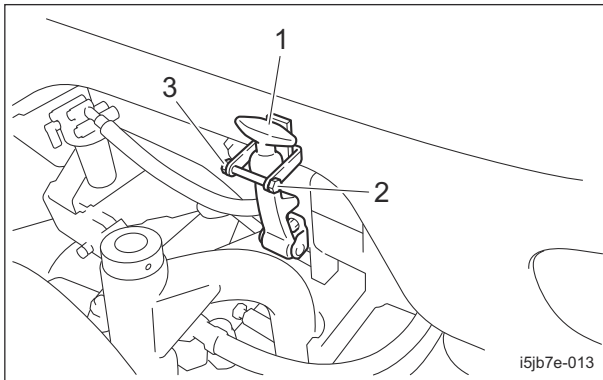

Opening and Closing of Hood_003

1	Rubber catch
2	Bolt
3	Nut

Removing and Installing of Rear Cover



Be careful not to pinch your fingers when you open or close the cover.

- Removing procedure :
 - Bring the seat to the most front position.
 - Remove the bolt on both sides of the rear cover.

- Remove the rear cover.

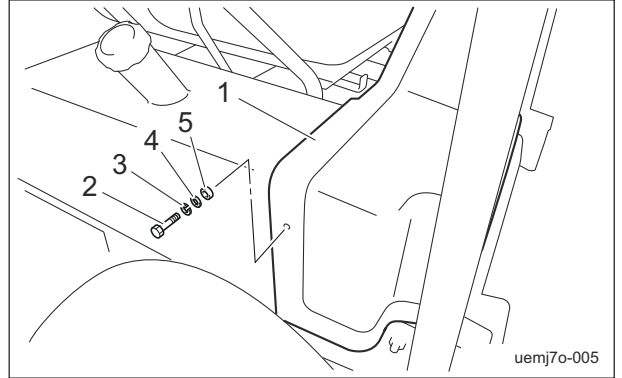

Removing and Installing of Rear Cover_001

1	Rear cover
2	Bolt
3	Spring washer
4	Washer
5	Rubber washer

- Installing procedure :
 - Bring the seat to the most front position.
 - Install the rear cover with the bolts.

Removing and Installing of Center Cover



Be careful not to pinch your fingers when you open or close the center cover.

- Procedure to remove the center cover
 - Bring the seat to the backmost position.
 - Completely raise the steering wheel.
 - Remove the bolt on both sides of the center cover.
 - Remove the center cover.

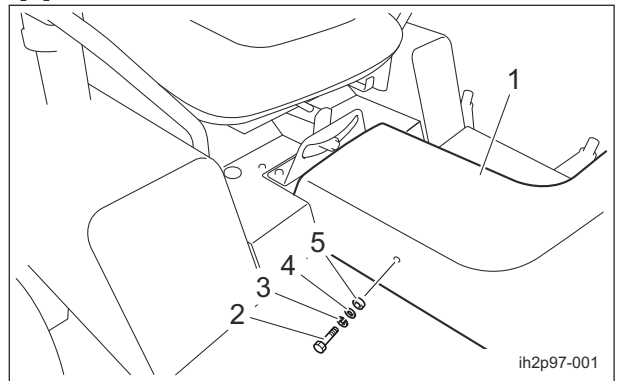

Removing and Installing of Center Cover_001

Handling Instructions

1	Center cover
2	Bolt
3	Spring washer
4	Washer
5	Rubber washer

2. Procedure to install the center cover
 - [1] Bring the seat to the backmost position.
 - [2] Completely raise the steering wheel.
 - [3] Install the center cover with the bolts.

Removing and Installing of Seatback Cover

Note:

Follow the same steps for the right and left seatback covers to remove and install.

1. Removing procedure:

- [1] Bring the seat to the frontmost position.
- [2] Remove the rear cover.
- [3] Remove the grommet.

Note:

The wire is removed together with the grommet.

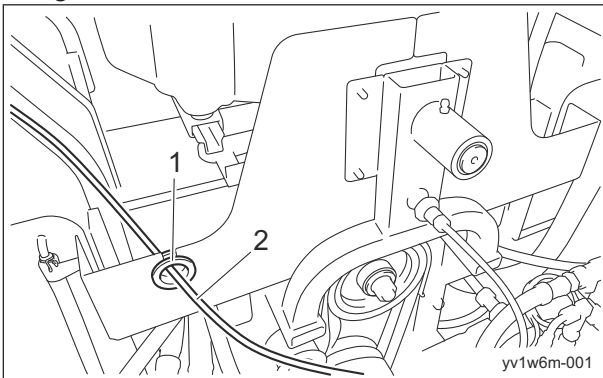

Removing and Installing of Seatback Cover_001

1	Grommet
2	Wire

- [4] Swing the seat to tilt it.

Note:
Tilt the seat so that the cover to be removed is facing down.
- [5] Remove the bolts mounting the seatback cover.

[6] Remove the seatback cover.

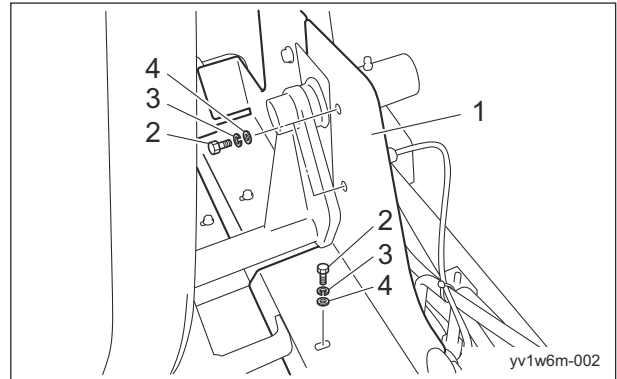

Removing and Installing of Seatback Cover_002

1	Seatback cover
2	Bolt
3	Spring washer
4	Washer

2. Installing procedure:

- [1] Bring the seat to the frontmost position.
- [2] Swing the seat to tilt it.

Note:

Tilt the seat so that the cover to be installed is facing down.

- [3] Install the seatback cover with the bolts.
- [4] Install the grommet and wire.
- [5] Install the rear cover.

Removing and Installing of Underseat Cover

⚠ Caution

Be careful not to pinch your fingers when you open or close the underseat cover.

Note:

Follow the same steps for the right and left underseat covers to remove and install.

1. Removing procedure :

- [1] Remove the rear cover.
- [2] Remove the seatback cover.
- [3] Swing the seat to tilt it.
- [4] Remove the bolts mounting the underseat cover.

Handling Instructions

[5] Remove the underseat cover.

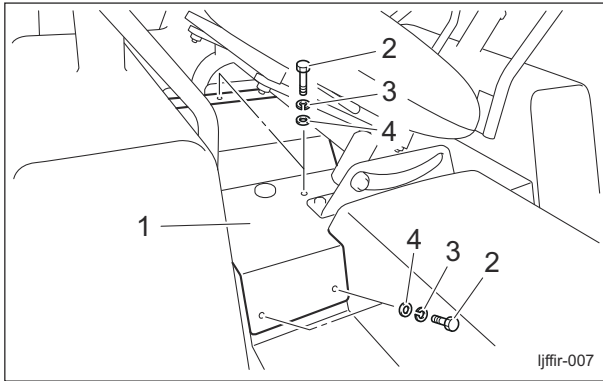

Removing and Installing of Underseat Cover_001

1	Underseat Cover
2	Bolt
3	Spring washer
4	Washer

2. Installing procedure :

- [1] Swing the seat to tilt it.
- [2] Install the underseat cover with the bolts.
- [3] Install the seatback cover.
- [4] Install the rear cover.

Inspection and Cleaning

Inspect and clean the machine with the goals of the followings.

- Accident prevention
- Failure prevention
- Performance retention

Make efforts for early detection of the machine failure and prevention of the sudden occurrence of trouble.

Perform maintenance and repair works immediately if any abnormality is found in the machine.

Hood

Inspection of Hood (Intake)

1. Make sure that there is no damage to the hood.
2. Make sure that the intake is not dirty.

Cleaning of Hood (Intake)

Important

An unclean hood intake may cause overheating or damage to the engine. It may also cause malfunction of the hydraulic system.

Important

While cleaning, do not allow water to get on the engine. This may cause damage to the engine.

If the intake has been contaminated with dust, be sure to clean it. After operating the machine in a dusty environment, it is important to remove dust as soon as possible.

1. Open the hood.
2. Carefully clean the inside and outside of the intake with water or compressed air.

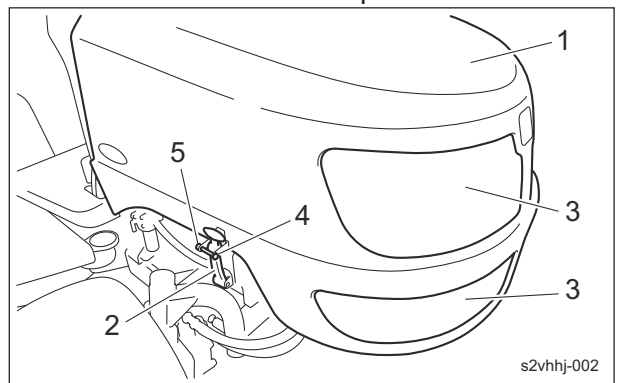

Cleaning of Hood (Intake)_001

1	Hood
2	Rubber catch
3	Intake
4	Bolt
5	Nut

Handling Instructions

Radiator

Inspection of Radiator

1. Make sure that there is no damage to the radiator.
2. Make sure that the radiator is not contaminated.

Cleaning of Radiator

1	Hood
2	Dust screen
3	Radiator
4	Air intake

3. Carefully clean the front and back of the radiator with water or compressed air.
4. Install the dust screen.
5. Close the hood.

Important

An unclean radiator may cause overheating or damage to the engine. It may also cause malfunction of the hydraulic system.

Important

While cleaning, do not allow water or dust to enter the air intake. This may cause damage to the engine.

Important

Do not use solid objects, such as a spatula or screwdriver, or high-pressure water to clean the radiator or oil cooler. Otherwise, special fins or tubes may be damaged, possibly resulting in reduced cooling performance or coolant leakage.

If the radiator has been contaminated with dust, be sure to clean it. After operating the machine in a dusty environment, it is important to remove dust as soon as possible.

1. Open the hood.
2. Pull the dust screen up to remove it.

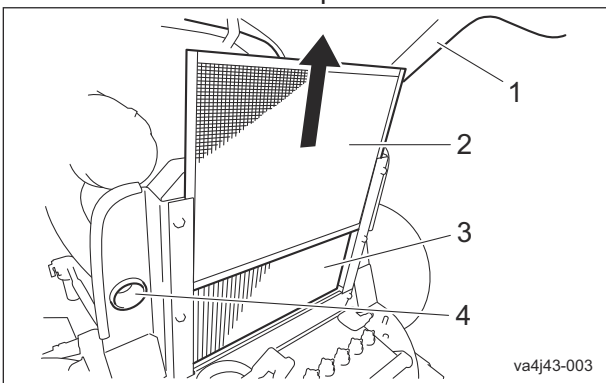

Cleaning of Radiator_001

va4j43-003

Coolant

Inspection of Coolant

Caution

Do not touch the radiator or coolant during engine operation or immediately after the engine has been turned off. Otherwise, you may get burned.

Caution

Inspection should take place after the engine has well cooled down.

1. Make sure that the coolant level in the reserve tank is between "FULL" and "LOW."

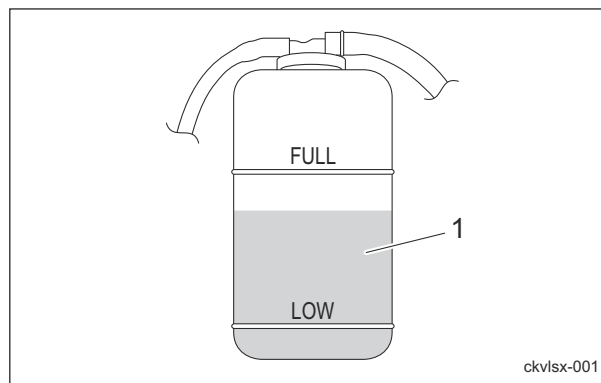

Inspection of Coolant_001

1	Reserve tank
---	--------------

Handling Instructions

Coolant Supply

Caution

Do not touch the radiator or coolant during engine operation or right after the engine has been turned off. Due to high temperatures, doing so could cause burns.

Caution

Supply coolant after the engine has well cooled down.

Caution

The radiator cap is pressurized. If you remove the radiator cap while the engine is overheated, hot steam will burst out, possibly resulting in burns. Make sure that the water temperature and pressure are reduced, and then grab the cap with a thick cloth and gradually open the cap.

Important

When you supply coolant, be sure to use clean water, such as tap water.

Important

Tightly close the radiator cap. If the cap is loose or incorrectly installed, the engine will be overheated due to water leakage, resulting in engine damage.

1. If the coolant level in the reserve tank is lower than the "LOW" mark, open the reserve tank cap and fill the tank with clean water up to the "FULL" mark.

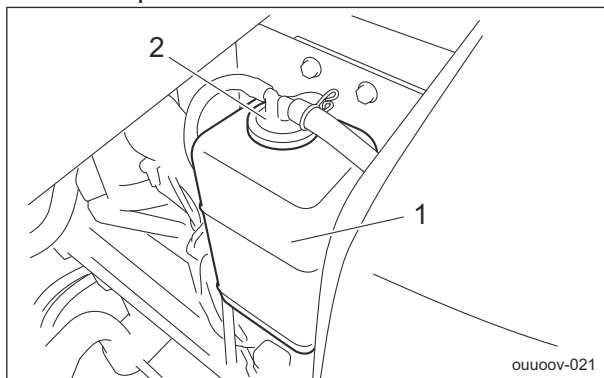

Coolant Supply_001

1	Reserve tank
2	Reserve tank cap

2. If no coolant is in the reserve tank, follow the steps below to fill the tank with clean water.
 - [1] Open the radiator cap, and then supply clean water up to the opening.
 - [2] Open the reserve tank cap, and then supply clean water up to the "FULL" mark.

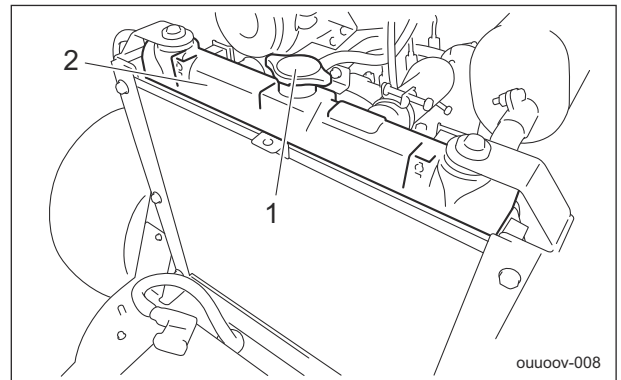

Coolant Supply_002

1	Radiator cap
2	Radiator

Hydraulic Oil

Inspection of Hydraulic Oil

The oil gauge is on the side of the hydraulic tank.

1. Lower the mower decks and maintain that position on a level surface.
2. Make sure that the oil level is at the middle of the oil gauge.

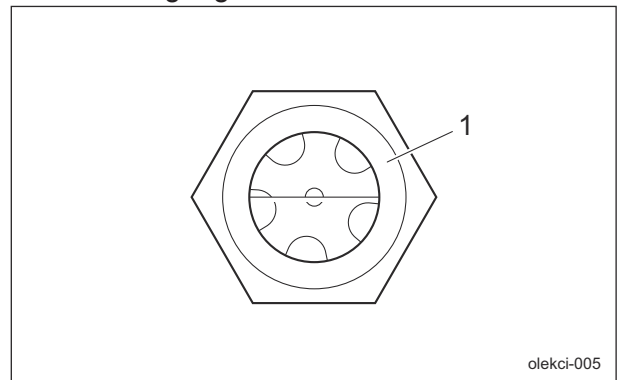

Inspection of Hydraulic Oil_001

1	Oil gauge
---	-----------

3. Check underneath the machine for oil leakage.

Handling Instructions

Supply of Hydraulic Oil

Important

Do not mix different types of oil.

Important

For the hydraulic oil to be used, consult Characteristics of Hydraulic Oil and use the oil whose characteristics are equivalent or superior to those specified there.

Especially regarding kinematic viscosity and viscosity index, use of hydraulic oil whose figures are less than those of the specified hydraulic oil will cause a malfunction in the hydraulic circuit.

Important

Supply hydraulic oil after checking the oil in the hydraulic tank has been sufficiently cooled down.

Oil level changes depending on the hydraulic oil temperature.

Characteristics of Hydraulic Oil

ISO Viscosity Grade		ISO VG46
Density	15 °C (59 °F)	0.873 g/cm ³ (0.0315 lb/in ³)
API Gravity		30.6
Flash Point (Open Cup)		230 °C (446 °F)
Pour Point		-30 °C (-22 °F)
Kinematic	40 °C (104 °F)	46 mm ² /s (46 cSt)
Viscosity	100 °C (212 °F)	7 mm ² /s (7 cSt)
Viscosity Index		109

Note:

In Japan, "Shell Tellus S2M46" meets the characteristics described above.

However, in other countries, the specification of Shell Tellus S2M46 can be below what is required.

Please check the product data sheet to ensure that it meets the requirements before using.

1. If the oil level is low, follow the steps below to supply oil.

■ #20001-21255

[1] Open the tank cap.

[2] Supply hydraulic oil through the oil filling port until the oil level reaches the middle of the oil gauge on the hydraulic tank.

[3] Tighten the tank cap securely.

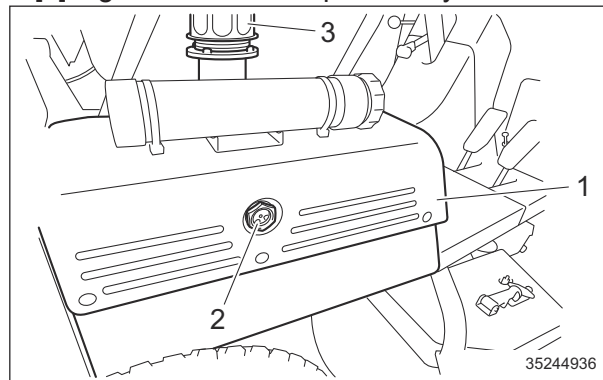

Supply of Hydraulic Oil_001

1	Hydraulic tank
2	Oil gauge
3	Tank cap

■ #21256-

[1] Loosen the bushing with a wrench and remove the oil filler plug.

[2] Supply hydraulic oil through the oil filling port until the oil level reaches the middle of the oil gauge on the hydraulic tank.

[3] Install the oil filler plug and tighten the bushing securely.

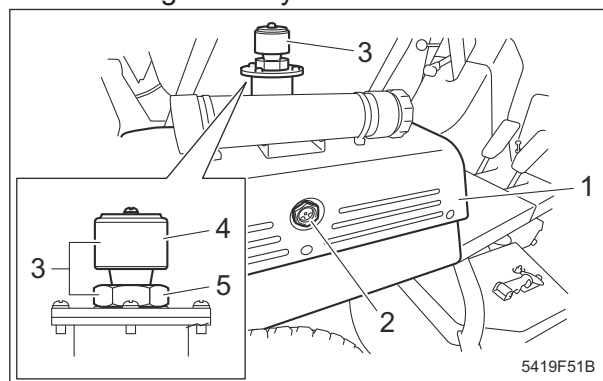

Supply of Hydraulic Oil_002

1	Hydraulic tank
2	Oil gauge
3	Oil filler plug
4	Air breather
5	Bushing

2. Start the engine, and then repeat the steps below a few times.

- Raise and lower the mower units.
- Turn the steering wheel left and right.
- Move forward and reverse.

Handling Instructions

3. Lower the mower decks and maintain that position on a level surface, and then check to see if the oil level is at the middle of the oil gauge. If necessary, supply oil.
4. Check underneath the machine for oil leakage.

Hydraulic Hoses

Inspection of Hydraulic Hoses and Pipes

Warning

When checking the hydraulic circuit for pinhole leaks or oil leakage from nozzles, do not use your hands. Use items such as paper or corrugated cardboard to find leakage points.

Be extremely careful with high-pressure oil as it may pierce your skin, resulting in personal accidents.

If fluid is injected into the skin it must be surgically removed within a few hours by a doctor familiar with this form of injury or gangrene may result.

1. Make sure that there is no wear, deterioration or damage in the hydraulic hoses and pipes.
2. Make sure that there is no looseness in the connecting portion of the hydraulic hoses and pipes.
3. Check underneath the machine for hydraulic oil leakage.

Air Cleaner

Inspection of Air Cleaner

A contaminated air cleaner element may cause malfunction of the engine.

1. Make sure that there is no damage to the air cleaner.
2. Make sure that the air cleaner element is not contaminated.

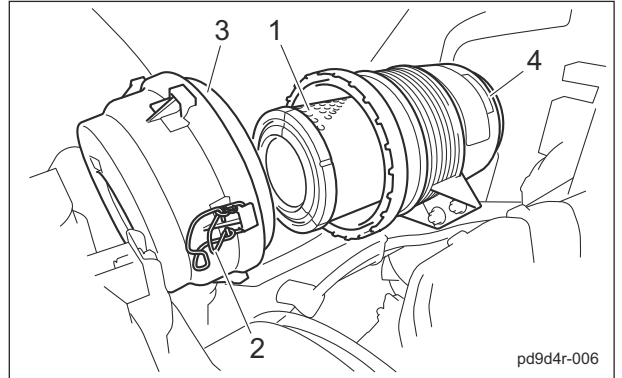

Inspection of Air Cleaner_001

1	Air cleaner element
2	Clip
3	Air cleaner cap
4	Air cleaner body

Cleaning of Air Cleaner

A contaminated air cleaner element may cause malfunction of the engine. To maximize the life of the engine, clean the air cleaner properly.

1. Follow the steps below to clean the air cleaner.
 - [1] Remove the clip, and then remove the air cleaner cap.
 - [2] Remove the air cleaner element.
 - [3] While paying close attention not to damage the air cleaner element, tap a solid portion of the air cleaner element or blow compressed air from its inside to remove dust and dirt.
 - [4] Attach the air cleaner element to the air cleaner body.
 - [5] Re-place the air cleaner cap, and then fix it securely using the clips.

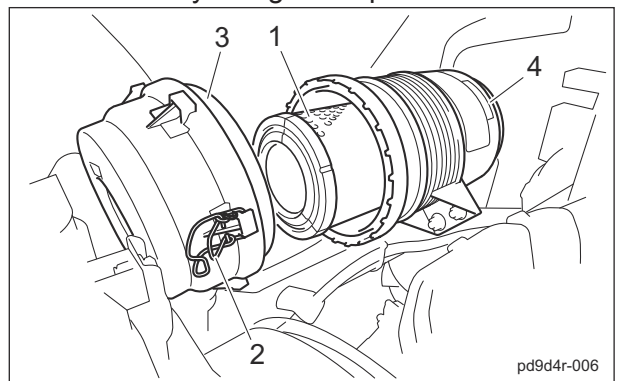

Cleaning of Air Cleaner_001

Handling Instructions

1	Air cleaner element
2	Clip
3	Air cleaner cap
4	Air cleaner body

Battery

Inspection of Battery

Danger

Keep away from fire while inspecting or charging the battery.
The battery may explode.

Caution

Implement after the engine and muffler etc. have well cooled down.
Otherwise, you may get burned.

Important

Be sure to stop the engine before inspecting or charging the battery.

Battery inspection items are described below.

1. Inspecting the exterior

Visually inspect the exterior of the battery, and check that there are no cracks, splits, missing sections, or abnormal deformation in the battery case, and that there is no electrolyte leaking.

If abnormalities are found, immediately replace the battery.

2. Cleaning the exterior

Warning

Do not clean the battery with a dry cloth. Cleaning the battery with a dry cloth may cause it to catch fire or explode due to static electricity.

Use a wet cloth for cleaning.

Inspect the vent plugs or vent holes on the side of the battery, and if they are blocked by dirt wash them with water to remove the blockage.

Continuing to use the battery with the vent holes blocked may cause the battery to rupture from increased internal pressure due to gases generated inside the battery.

3. Inspecting the mounting bracket

Inspect whether the battery is secured firmly with the mounting bracket.

If the bracket is loose, tighten the mounting bracket nuts until the battery is secured firmly.

An improperly mounted battery may cause damage to the battery case or electrolyte leaks due to the battery moving with vibrations while traveling.

4. Inspecting the cable terminals

If the connection between the battery terminals and vehicle's cable terminals are loose, tighten the nuts until the cable terminals are secured firmly.

Insufficiently tightened terminals may result in poor battery charging, damage to the terminals due to poor contacts, or an explosion.

If the terminals are corroded, rub them clean with a wire brush or fine grit sandpaper, and lightly apply anti-rust grease.

5. Inspecting the electrolyte level and refilling

Warning

Do not allow the battery fluid level to become lower than the LOWER LEVEL (minimum fluid level line).

The battery may explode if it is used or charged while the battery fluid level is at the LOWER LEVEL (minimum fluid level line).

Warning

When refilling, do not fill purified water above the UPPER LEVEL line.

Doing so may result in electrolyte leaks.

Clean the areas around the battery fluid level lines using a cloth damped with water to check the electrolyte level from the side of the battery.

Make sure that the battery fluid level is between the UPPER LEVEL (maximum fluid level line) and the LOWER LEVEL (minimum fluid level line).

Refill with purified water up to the UPPER LEVEL line if the level is lower than halfway between the UPPER LEVEL and LOWER LEVEL lines.

Handling Instructions

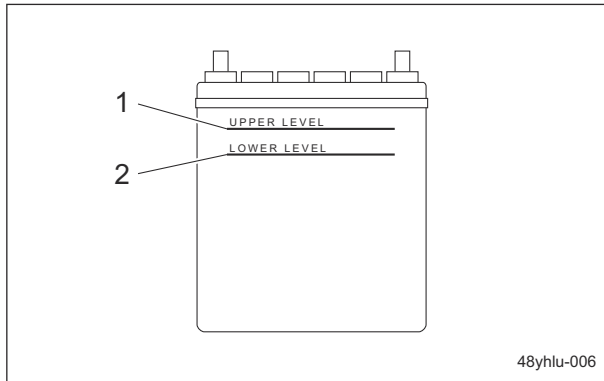

Inspection of Battery_001

1	UPPER LEVEL line
2	LOWER LEVEL line

Supply of Battery Fluid

Danger

Be careful not to let your skin, eyes or clothes, etc., come into contact with the battery fluid or accidentally swallow the fluid. Should your skin or clothes come into contact with the battery fluid, immediately wash them away with water.

Danger

When you supply battery fluid, wear protective garments and safety glasses, etc.

Warning

Do not allow the battery fluid level to become lower than the LOWER LEVEL (minimum fluid level line). The battery may explode if it is used or charged while the battery fluid level is at the LOWER LEVEL (minimum fluid level line).

Warning

When refilling, do not fill purified water above the UPPER LEVEL (maximum fluid level line). Doing so may result in electrolyte leaks.

Caution

Implement after the engine and muffler etc. have well cooled down. Otherwise you may get burned.

If the battery fluid level is lower than halfway between the UPPER LEVEL (maximum fluid level line) and LOWER LEVEL (minimum fluid level line), add purified water.

1. Loosen the vent plug and remove it.
2. Add purified water up to the UPPER LEVEL (maximum fluid level line)
3. Tighten the vent plug securely.

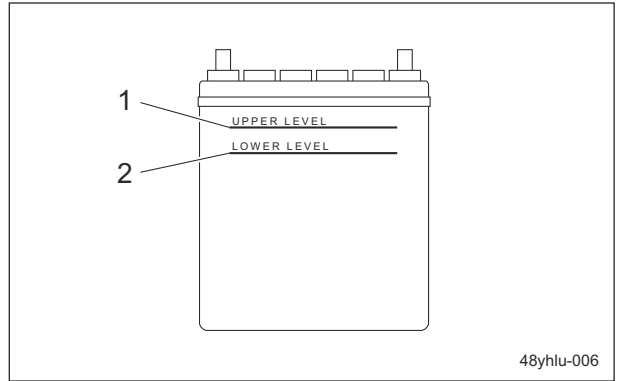

Supply of Battery Fluid_001

1	Maximum fluid level line
2	Minimum fluid level line

Electrical Wiring

Inspection of Electrical Wiring

Important

Electrical short circuit will cause fire, electrical leakage and malfunction of electrical equipments.

1. Make sure that there is no defacement in wires and terminals.
2. Make sure that there is no deterioration or damage in wires and terminals.
3. Make sure that there is no looseness in wiring connections.
4. Make sure that there is no poor terminal connection.

Handling Instructions

Tire

Inspection of Tires

1. Check the pneumatic pressure of the tires.
2. Make sure that there are no cracks, damage or abnormal wear.

	Tire size	Pneumatic pressure	
Front wheel	21 x 11.00 - 10	140 kPa (1.4 kgf/cm ²)	20 psi
Rear wheel	21 x 11.00 - 10	140 kPa (1.4 kgf/cm ²)	20 psi

Brake

Inspection of Brake Pedal

1. Make sure that there is no play in the pedal.
2. Make sure that the pedal moves smoothly.
3. Make sure that there is no abnormal sound when the pedal is depressed.
4. Make sure that the pedal does not touch the floorboard when the pedal is depressed.

Inspection of Parking Brake

1. Make sure that the parking brake is applied after depressing the brake pedal and pulling the parking brake lever.
2. Make sure that the parking brake is not applied even slightly after depressing the brake pedal to release the parking brake lever.

Inspection of Knife Brake

Make sure that the rotary knife stops rotating within 7 seconds after the knife rotation lever is set from the "Rotation" position to the "Stop" position.

Clutch

Inspection of Clutch Lever

1. Make sure that there is no play in the lever.
2. Make sure that the lever moves smoothly.
3. Make sure that there is no abnormal sound when the lever is moved.

Belt

Inspection of Belt

Warning

The engine must be stopped when the belt is inspected.

Warning

If you have removed the cover during inspection, make sure that you replace it in the original position securely. If the cover remains removed, the operator may come in contact with the rotating objects or belt, possibly resulting in injuries.

Important

A slacking or damaged belt or damaged fan may cause overheating or lack of a battery charge.

1. Press the middle of the belt with your finger to check the belt tension.
2. Make sure that there are no cracks, damage or abnormal wear.

Wire

Inspection of Wire

1. Make sure that the wire is not cracked or damaged.
2. Make sure that the wire is not worn.
3. Make sure that the wire is not crushed.
4. Make sure that the wire is not bent.
5. Make sure that the wire is not corroded or rusted.

Handling Instructions

Around The Engine

Inspection of Engine-Associated Parts

Caution

Perform operations after the muffler, engine and other parts have sufficiently cooled. Otherwise, you may get burned.

1. Check for damages and dirt.
2. Check the mount for looseness and cracks.
3. Check for liquid leakage.
4. Check on and around the muffler for grass clippings and flammable materials.

Cleaning of Engine-Associated Parts

Caution

Perform operations after the muffler, engine and other parts have sufficiently cooled. Otherwise, you may get burned.

1. Clean clippings and remove dirt.
2. Blow compressed air to clean any grass or flammable materials that may be attached on or around the muffler.

Engine Oil

Inspection of Engine Oil

Caution

Perform operations after the muffler, engine and other parts have sufficiently cooled. Otherwise, you may get burned.

Important

Securely tighten the oil level gauge and oil filler cap.

1. Stop the engine, wait for 10 to 20 minutes for the engine to cool down, and then check the oil level.

2. Position the machine so that the engine will be level, then insert the oil gauge all the way to check the oil level.

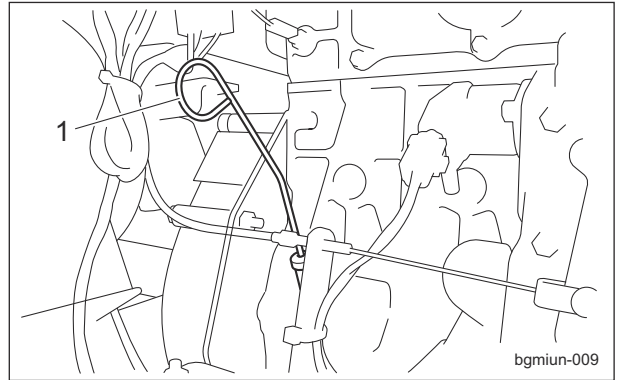

Inspection of Engine Oil_001

1	Oil level gauge
---	-----------------

3. The appropriate oil level should be between the upper and lower limit lines on the gauge.

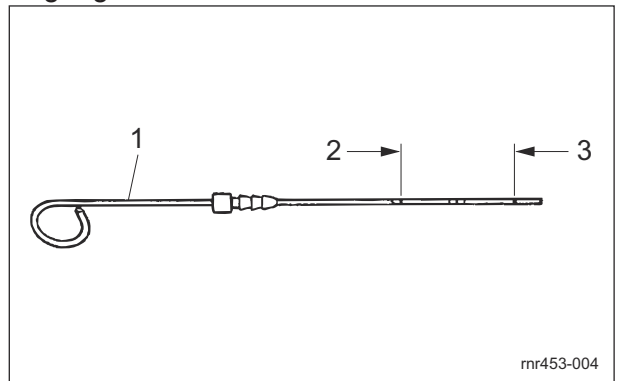

Inspection of Engine Oil_002

1	Oil level gauge
2	Upper limit
3	Lower limit

Handling Instructions

Supply of Engine Oil

Important

Do not supply too much engine oil. Otherwise, the engine may be damaged.

Important

Do not mix different types of engine oil.

Important

Be sure to use engine oil that is classified as API Service Grade CF or higher, with an SAE Viscosity that is appropriate for the operating environment (ambient temperature).

Important

Securely tighten the oil level gauge and oil filler cap.

1. If the engine oil level is lower than the lower limit line on the oil level gauge, supply engine oil through the oil filling port. Remove the oil filler cap, and then supply new engine oil until the oil reaches a level in between the upper and lower limit lines on the oil level gauge.
2. Re-place the oil filler cap.

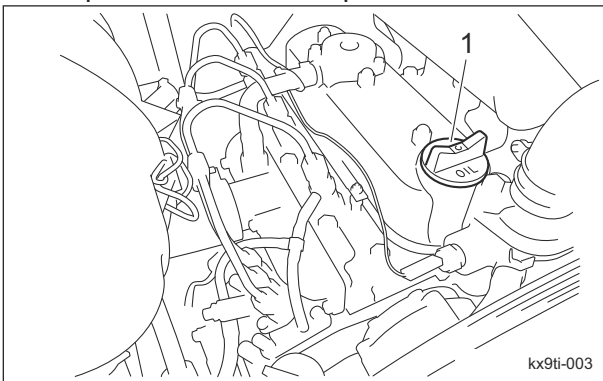

Supply of Engine Oil_001

1 Oil filler cap

3. It will take a while for the supplied engine oil to descend into the oil pan. Check the oil level again 10 to 20 minutes after supplying the oil.

Fuel

Inspection of Fuel Quantity

Position the machine so it is level, and then observe the fuel gauge located on the fuel tank to check the fuel level.

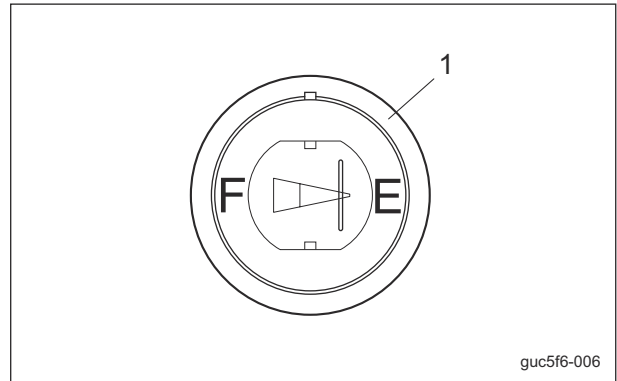

Inspection of Fuel Quantity_001

1 Fuel gauge

Fuel Supply

Warning

Do not supply fuel above F (FULL) level of the fuel gauge.
If you supply too much fuel, it might overflow from the fuel cap when you travel or work on a slope.

Warning

Keep fire away while refueling.
Do not smoke while refueling.

If the fuel gauge located on the fuel tank indicates a level close to E (EMPTY), supply fuel (diesel) at your earliest convenience. The fuel tank capacity is approximately 23.0 dm³ (23.0 L).

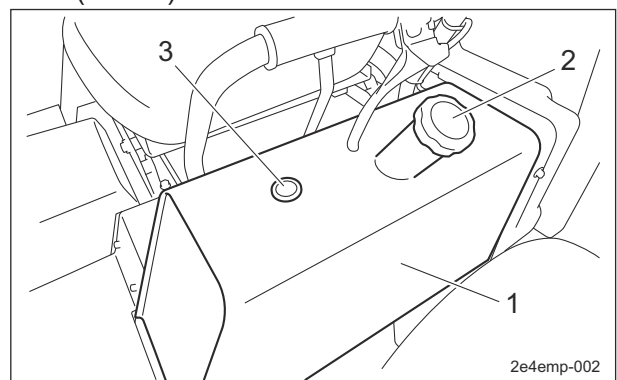

Fuel Supply_001

Handling Instructions

1	Fuel tank
2	Tank cap
3	Fuel gauge

Fuel Filter

Inspection of Fuel Filter

1. Make sure that there is no fuel leakage.
2. Make sure that the filter is not damaged.
3. Make sure that the filter is not contaminated.

Liquid Leakage

Inspection of Liquid Leakage

Caution

When performing maintenance on the hydraulic system, lower the mower decks.

Important

After approximately 50 hours of operation, some tightened portions may be loosened and liquid such as oil may leak. Be sure to retighten the parts.

1. Check the bottom of the machine for leakage of liquid such as oil, water, fuel, etc.
2. Locate the leakage and identify the type of liquid.
Ignoring leakage will cause further trouble.

Bolts and Nuts

Inspection of Bolts and Nuts

Important

The bolts and nuts may be loosened at the earlier stage of the use. Be sure to retighten or replace before operating the machine whenever there is any abnormality.

1. Check the bolts and nuts for looseness and coming off.
2. Check the bolts and nuts for cracks and damages.
3. Check the bolts and nuts for rust.
4. Check around the bolts and nuts for traces of rust fluid.

5. Check for unequal bolt length.
6. Check the bolts and nuts for stripped threads and abrasion.

Inspection of Wheel Mounting Bolt

Important

Tighten the wheel mounting bolts on the specified torque by using a torque wrench.

1. Check the wheel mounting bolts and wheel nuts for looseness and coming off.
2. Check the wheel mounting bolts and wheel nuts for cracks and damages.
3. Check the wheel mounting bolts and wheel nuts for rust.
4. Check around the wheel mounting bolts and wheel nuts for traces of rust fluid.
5. Check the wheel mounting bolts for unequal bolt length.
6. Check the wheel mounting bolts and wheel nuts for stripped threads and abrasion.

Handling Instructions

Adjustment before Work

Adjustment of Steering Wheel Position

Warning

Since it is dangerous, do not adjust while traveling.

Caution

Be sure the steering wheel position is securely locked. It may result in an unexpected accident if it becomes loose while traveling.

The steering wheel position can be adjusted up or down. Adjust the position according to the operator's body size. Shift the tilt lever to the "FREE" position, move the steering wheel to the position that suits your work requirements, and then shift the tilt lever to the "LOCK" position to secure the steering wheel in place.

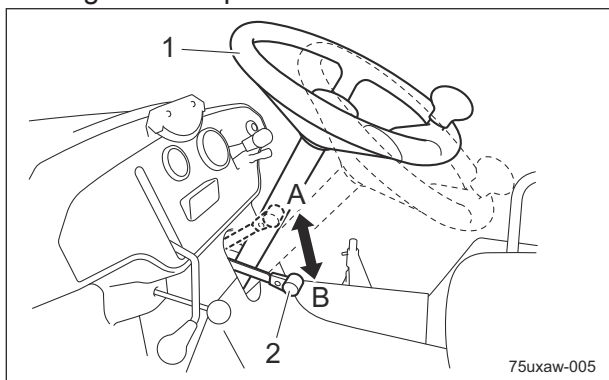

Adjustment of Steering Wheel Position_001

1	Steering wheel
2	Tilt lever
A	FREE (released)
B	LOCK (locked)

Adjustment of Seat Position

Warning

Do not make an adjustment while traveling since it is dangerous.

1. Use the adjustment lever to adjust the seat back and forth. Adjust the position according to the operator's body size. The adjustment lever is located beneath the front part of the seat.

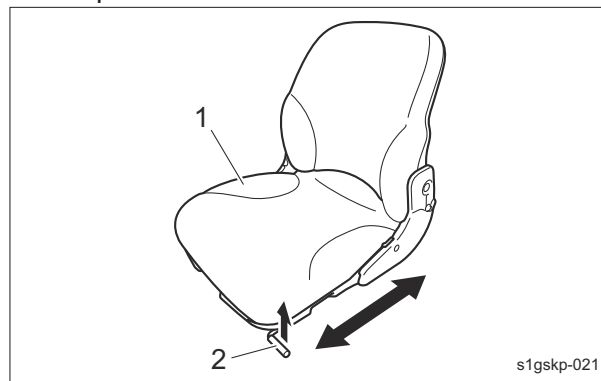

Adjustment of Seat_001

1	Seat
2	Adjustment lever

2. Grip the adjustment lever and swing the seat to the left and right to adjust it to one of five positions. Use this to adjust the position while operating on contours. The adjustment lever is located at the top of the fuel tank.

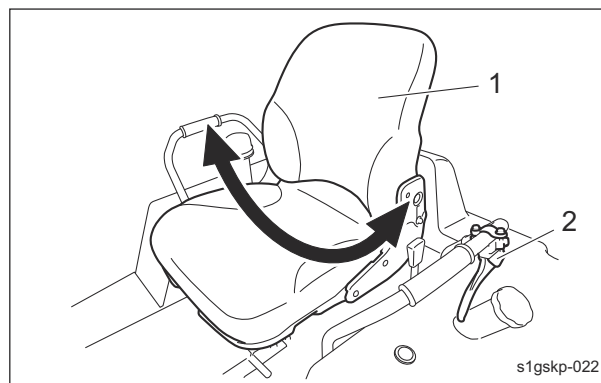

Adjustment of Seat_002

1	Seat
2	Adjustment lever

Handling Instructions

Start/Stop of Engine

Procedure to Start Engine

Caution

Before starting the engine, make sure that there are no other people or obstacles around the machine.

Important

Starter operation must take 15 seconds or less.
If the engine does not start, stop using the battery for 30 to 60 seconds to avoid exhausting the battery.

1. Make sure that the fuel cock is open.

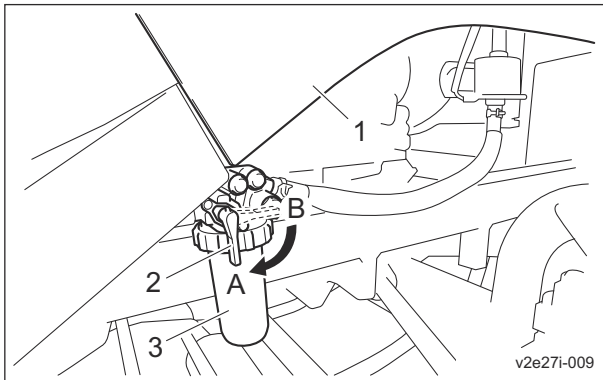

Procedure to Start Engine_001

1	Hood
2	Fuel cock
3	Fuel filter
A	Open
B	Close

2. Sit on the seat.
3. Make sure that you have depressed the brake pedal and applied the parking brake lever.
4. Make sure that the knife rotation lever is set to the "Stop" position.
5. Make sure that the traveling pedal is in the neutral position.

6. Shift the throttle lever halfway from the "Low speed" position toward the "High speed" position.

Important

The thermo-start lamp turns off at the specified time. However, the lamp turning off is not related to the glow plug generating heat. If the ignition key is left in the "GLOW" position after the lamp is turned off, the plug will still generate heat. The lamp will stay illuminated for five seconds.

7. Switch the ignition key to the "GLOW" position.

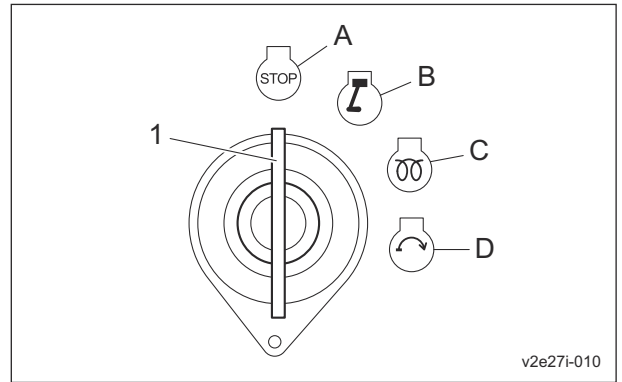

Procedure to Start Engine_002

1	Ignition key
A	OFF
B	ON
C	GLOW
D	START

8. Make sure that the thermo-start lamp is turned on.

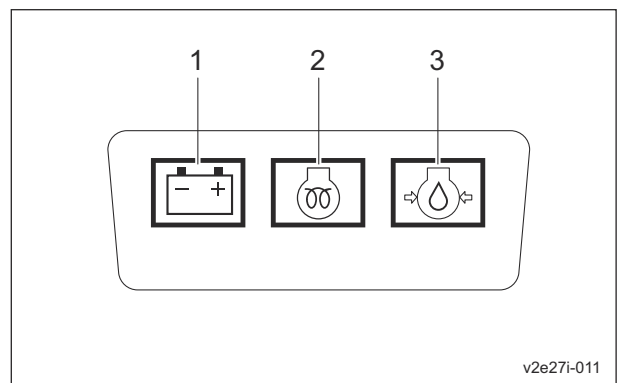

Procedure to Start Engine_003

1	Charge lamp
2	Thermo-start lamp
3	Oil pressure lamp

Handling Instructions

Important

Quickly returning the ignition key from the "START" position to the "ON" position may result in damage to the machine.

9. After the thermo-start lamp turns off, immediately set the ignition key to the "START" position.
10. When the starter starts rotating and the engine starts, return the ignition key to the "ON" position slowly.
11. Make sure that the charge lamp and engine oil pressure lamp turn off. If they do not turn off, stop the engine and inspect the machine.
12. Move the throttle lever to the "Low speed" position, and then warm up the engine so that the needle points above "C" on the water temperature gauge.

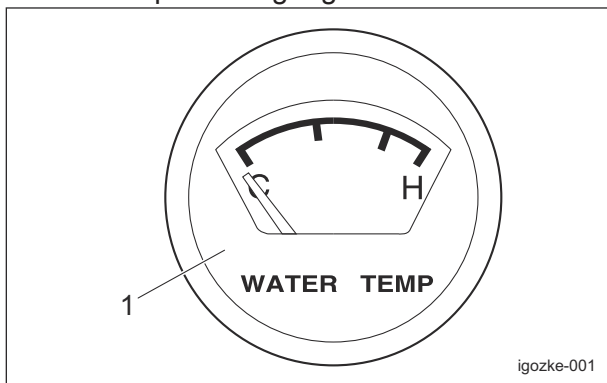

Procedure to Start Engine_004

1 Water temperature gauge

13. Gradually move the throttle lever to the "High speed" position.

Procedure to Stop Engine

1. Set the traveling pedal to the neutral position.
2. Depress the brake pedal, and then apply the parking brake.
3. Set the knife rotation lever to the "Stop" position.
4. Shift the throttle lever to the "Low speed" position, and then idle the machine for 1-2 minutes.
5. Switch the ignition key to the "OFF" position.
6. Make sure that the engine has stopped.
7. Remove the ignition key.
8. Leave the driver's seat.

Parking and Stopping

Procedure to Leave The Machine

Caution

If the brakes are not sufficiently effective, use the wheel stoppers to secure the machine.

Caution

Never park the machine on a slope.

1. Park the machine on level ground.
2. Apply the parking brake.
3. Stop the engine.
4. Remove the ignition key.
5. Install the cap to the key switch.
6. Get off the driver's seat.

Move

Traveling Procedure

Caution

Under any circumstances drive the machine at such a speed that you can stop it immediately for emergencies.

Important

Do NOT start to move or stop the machine abruptly. It will damage the hydraulic system or result in oil leakage.

1. Start the engine.
2. Raise the mower decks.
3. Shift the throttle lever to the "High speed" position to run the engine at the maximum rpm.
4. Depress the brake pedal to release the parking brake.
5. Release the brake pedal.
6. Slowly depress the traveling pedal.
7. The machine starts traveling.
8. Release the traveling pedal and depress the brake pedal to stop the machine.

Cutting Work

Cutting Operation

Caution

Cutting work must be performed at an appropriate speed for the site and location. When cutting bumpy surfaces, keep the engine rpm steady, and slow down the cutting speed.

Caution

All persons other than the operator must keep a safe distance from the machine.

Important

Do NOT start to move or stop the machine abruptly. It will damage the hydraulic system or result in oil leakage.

1. Start the engine.
"Procedure to Start Engine" (Page 5-17)
2. Depress the brake pedal to release the parking brake.
3. Shift the throttle lever to the "High speed" position to run the engine at the maximum rpm.
4. Shift the mower deck up/down switch to the "DOWN" position to lower the mower decks.
5. Slowly set the knife rotation lever to the "Rotation" position to rotate all rotary knives.
6. Depress the traveling pedal to start cutting work.

Note:

While operating on a slope, adjust the angle of the seat for better comfort.

Transporting

Transporting Procedure

When loading the machine into a trailer or a truck to transport it, drive the machine forward. When unloading, drive the machine in reverse. If the roof is installed on the machine, remove it.

The roof may be damaged by wind pressure.

Handling Instructions

Precautions for MaintenancePage 6-2

Jacking Up The Machine Page 6-2

 About Jacking Up The MachinePage 6-2

 Jack-Up PointsPage 6-2

Greasing Page 6-3

 About GreasingPage 6-3

 Greasing Points Page 6-4

Lubrication Page 6-6

 About LubricationPage 6-6

 Lubricating Points Page 6-7

Adjustment and Replacement Page 6-8

 Replacement of TiresPage 6-8

 Adjustment of Belt Tension Page 6-9

 Change of Coolant Page 6-11

 Replacement of Hydraulic Oil Page 6-13

 Replacement of Hydraulic Oil Filter Page 6-14

 Replacement of Air Breather
 ElementPage 6-15

 Replacement of Air Cleaner Element .. Page 6-15

 Change of Engine Oil Page 6-16

 Replacement of Engine Oil Filter Page 6-17

 Replacement of Fuel Filter Element Page 6-17

 Change of Transmission Oil Page 6-18

Storage Page 6-19

 Long-Term StoragePage 6-19

Maintenance

Precautions for Maintenance

Warning

The chapter "Maintenance" in this manual describes practical measures which should be performed by a mechanic with expertise. The owner should instruct the mechanic with expertise to perform maintenance service for this machine.

Caution

First, learn well the operations you plan to perform.

Important

Use tools appropriate for each operation.

Important

Use Baronsess genuine parts for replacement and accessories. Our product warranty may be void if you use non-genuine parts for replacement or accessories.

Jacking Up The Machine

About Jacking Up The Machine

Warning

When replacing a tire or beginning any other maintenance or repairs, be sure to chock the wheels to prevent the machine from moving. Before jacking up the machine, park it on a hard, flat surface such as a concrete floor and remove any obstacles that could prevent you from performing the work safely. When necessary, use an appropriate chain block, hoist, or jack. Support the machine securely with jack stands or appropriate blocks. Failure to do so may cause the machine to move or fall, resulting in injury or death.

Important

Only place a jack under the jack-up points specified. Placing a jack at any other point will result in damage to the frame or other parts.

Use the jack-up points identified in this manual when jacking up the machine.

Jack-Up Points

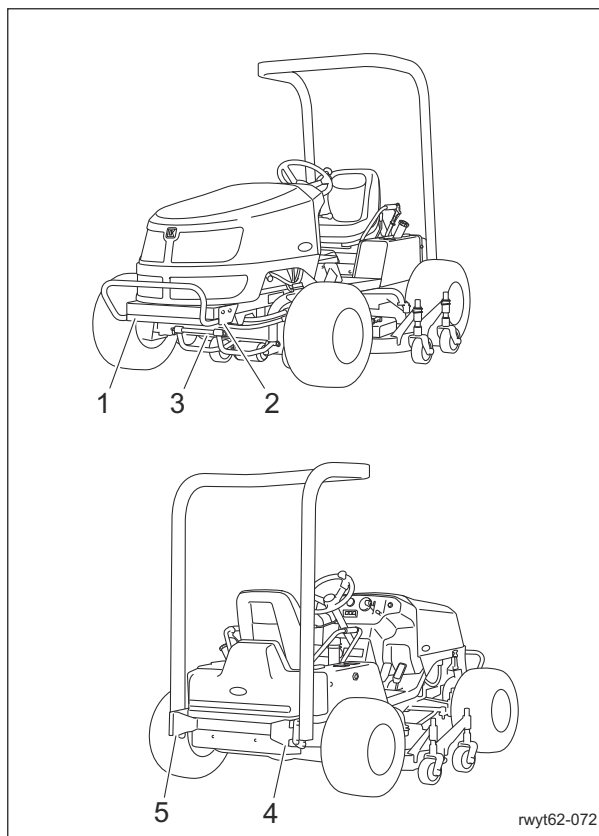

Jack-Up Points_001

	Jack-up Points
1	Front right frame
2	Front left frame
3	Center of pivot
4	Rear right frame
5	Rear left frame

1. Front right frame

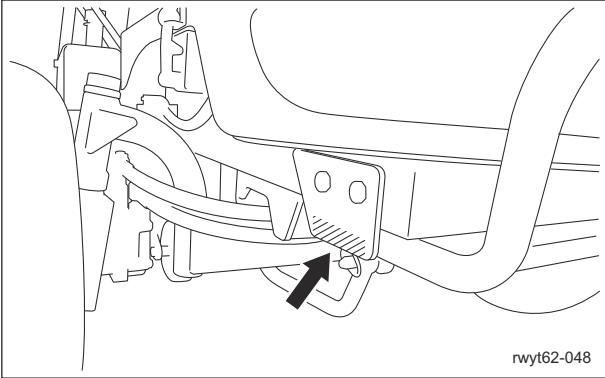

rwyt62-048

Jack-Up Points_002

5. Rear left frame

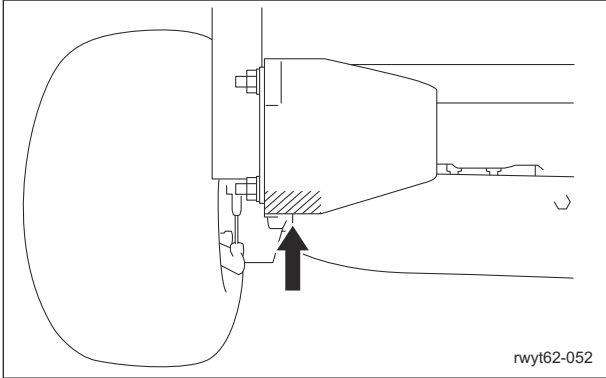

rwyt62-052

Jack-Up Points_006

2. Front left frame

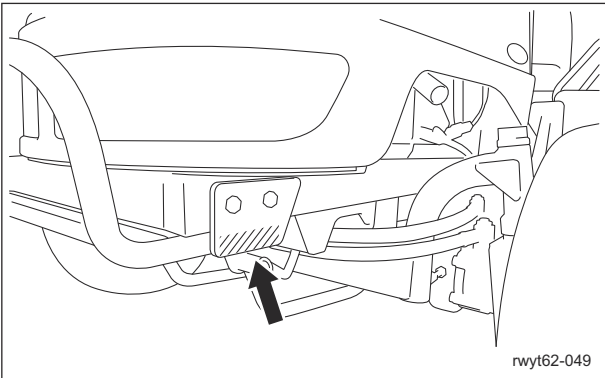

rwyt62-049

Jack-Up Points_003

Greasing

About Greasing

Since there may be adhesion or damage due to lack of grease on moving parts, they must be greased.

Add urea-based No. 2 grease in accordance with the Maintenance Schedule.

Other locations where the specified grease or lubricant is used are indicated in "Greasing Points".

Add grease using the specified grease or lubricant.

3. Center of pivot

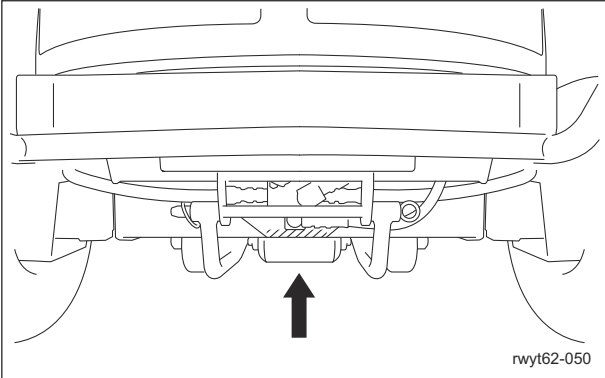

rwyt62-050

Jack-Up Points_004

4. Rear right frame

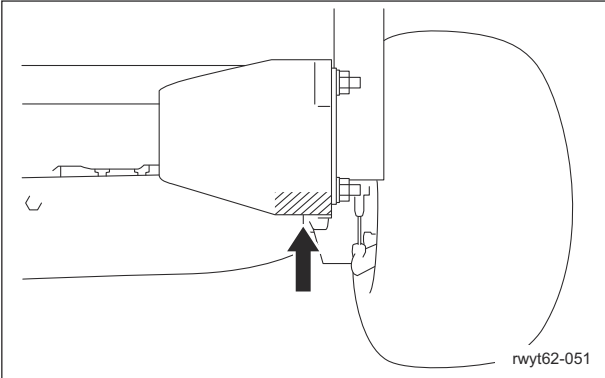

rwyt62-051

Jack-Up Points_005

Maintenance

Greasing Points

Grease nipples are installed in the following locations.

Add grease every 50 hours of operation.

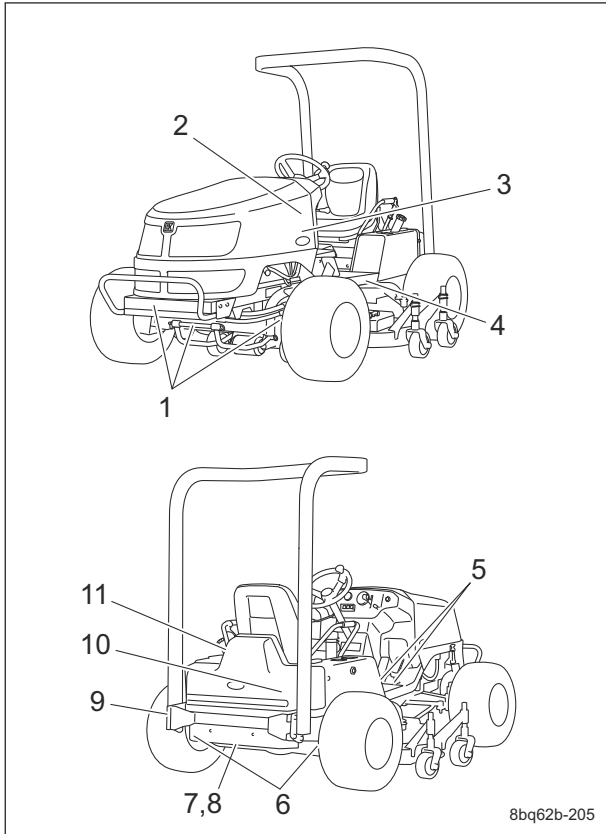

Greasing Points_001

	Location	No. of Greasing Points
1	Pivot	3
2	Knife rotation lever fulcrum	1
3	Brake pedal shaft fulcrum	1
4	Chain wheel mounting shaft fulcrum	2
5	Traveling pedal shaft fulcrum	2
6	Brake lever shaft	2
7	Joint fulcrum	2
8	Joint connector	1
9	Tension shaft fulcrum	1
10	Cam lever shaft fulcrum	1
11	Seat mounting bracket	1

1. Pivot

Jack up the machine and apply grease.

Middle between the front wheels

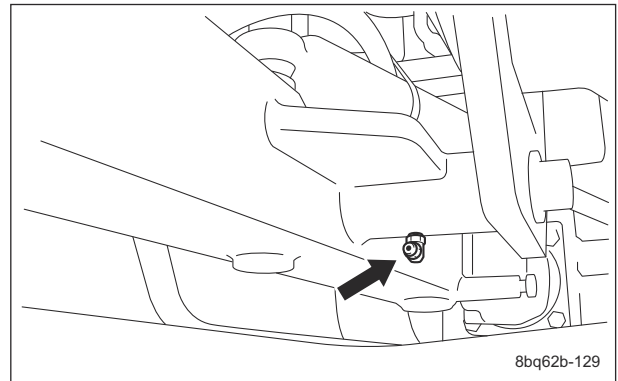

Greasing Points_002

Front right wheel

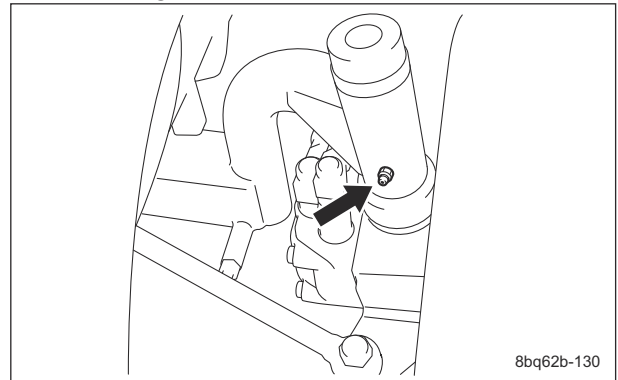

Greasing Points_003

Front left wheel



Greasing Points_004

2. Knife rotation lever fulcrum

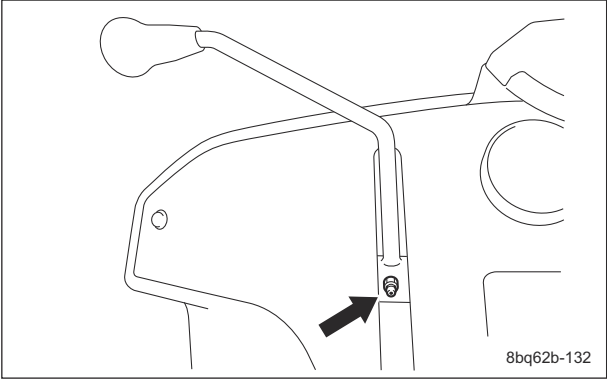

Greasing Points_005

3. Brake pedal shaft fulcrum

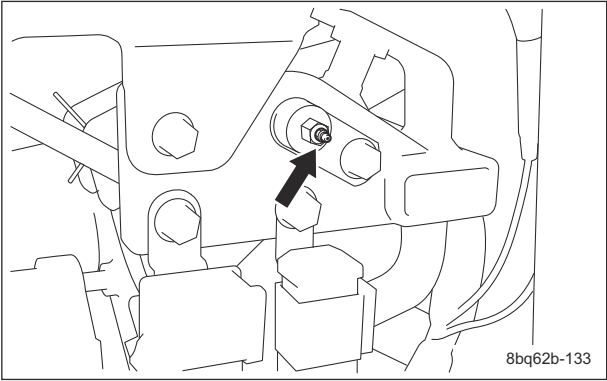

Greasing Points_006

4. Chain wheel mounting shaft fulcrum
 One greasing point is provided to each of the right and left chain wheel mounting shaft fulcrums.

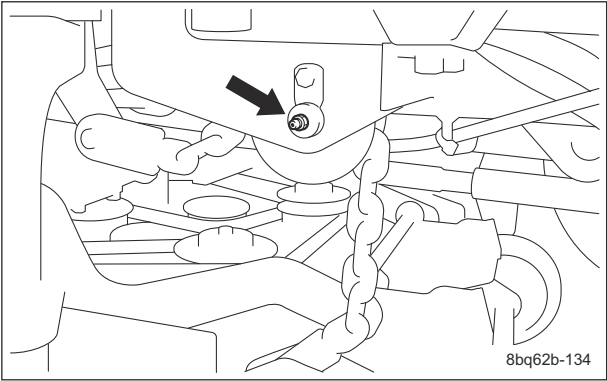

Greasing Points_007

5. Traveling pedal shaft fulcrum

Forward pedal

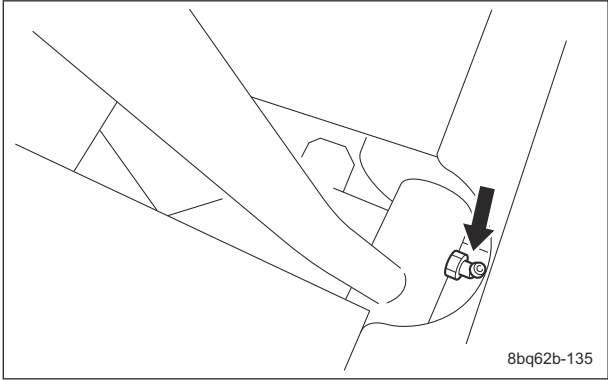

Greasing Points_008

Reverse pedal

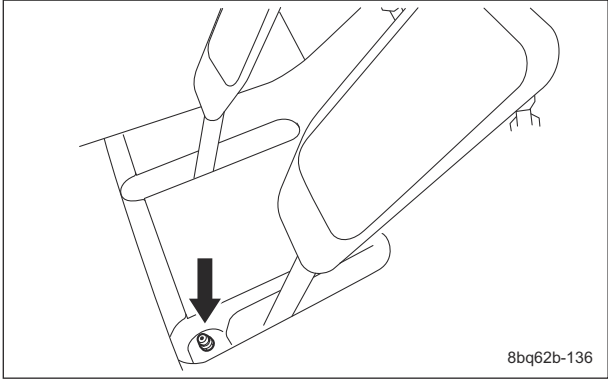

Greasing Points_009

6. Brake lever shaft
 One greasing point is provided to each of the right and left brake lever shafts.

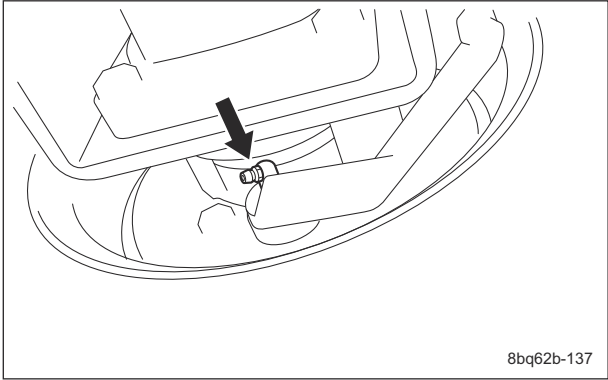

Greasing Points_010

Maintenance

7. Joint fulcrum

One greasing point is provided to each of the two fulcrums of the joint.

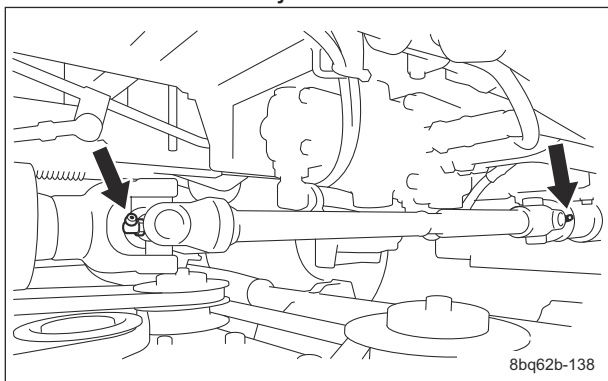

Greasing Points_011

8. Joint connector

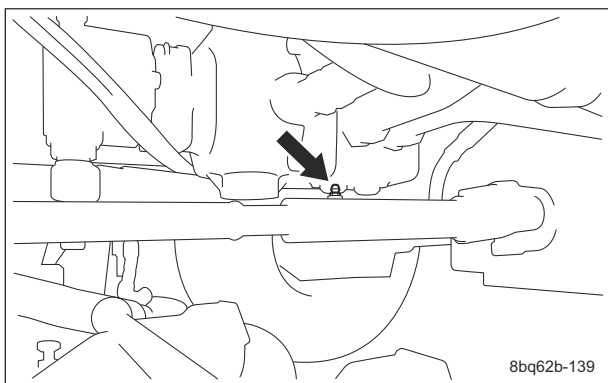

Greasing Points_012

9. Tension shaft fulcrum

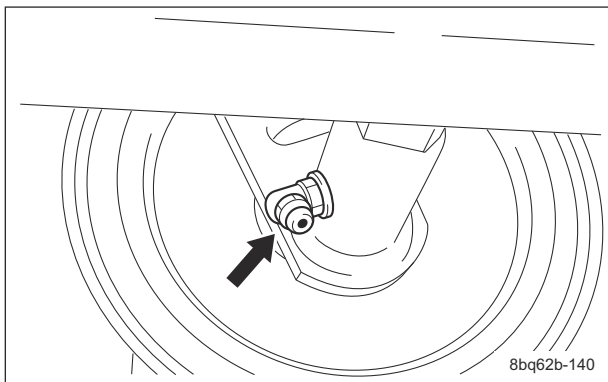

Greasing Points_013

10. Cam lever shaft fulcrum

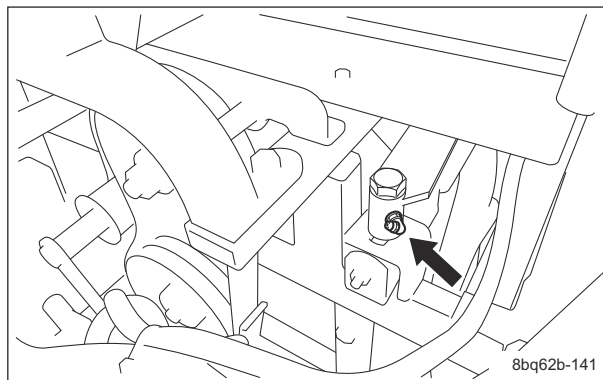

Greasing Points_014

11. Seat mounting bracket

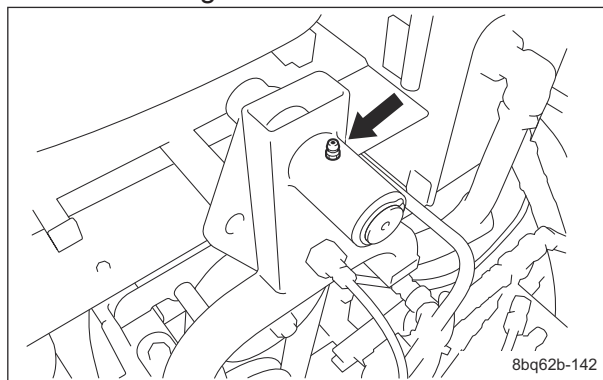

Greasing Points_015

Lubrication

About Lubrication

It is necessary to lubricate moving parts so that they will not become stuck or damaged. The locations where lubricant is used are indicated in "Lubricating Points". Apply the lubricant.

Lubricating Points

Apply lubricant at the following locations every 50 hours of operation.

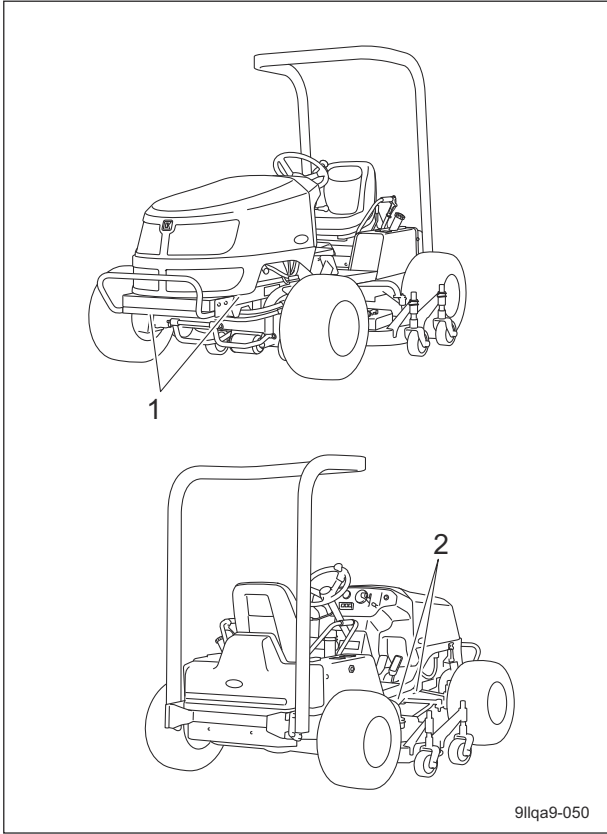

Lubricating Points_001

	Location	No. of lubricating points
1	Steering cylinder spherical bearing	2
2	Mower up/down cylinder spherical bearing	2

1. Steering cylinder spherical bearing
There are two points.

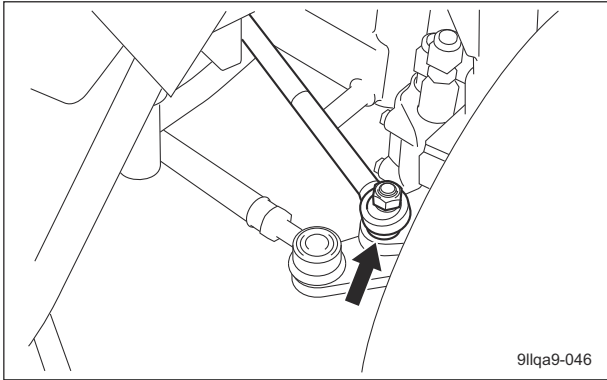

Lubricating Points_002

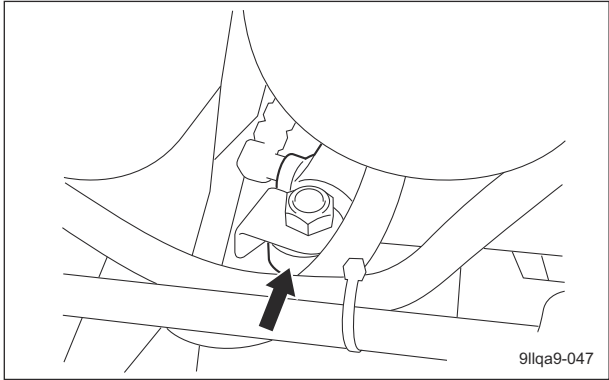

Lubricating Points_003

2. Mower up/down cylinder spherical bearing
There are two points.

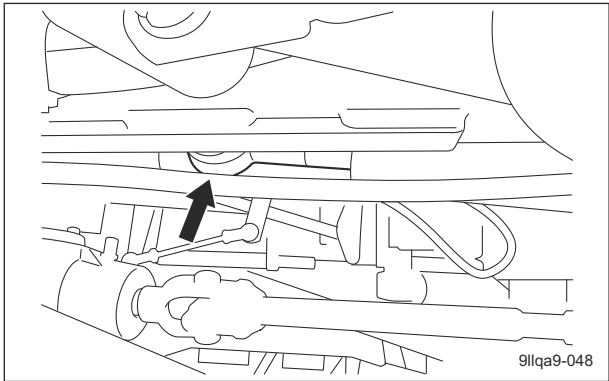

Lubricating Points_004

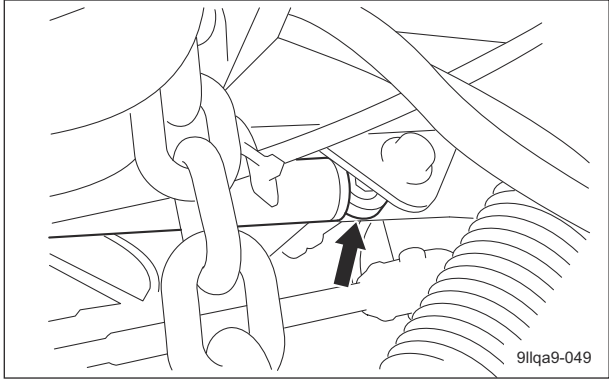

Lubricating Points_005

Adjustment and Replacement

Replacement of Tires

Replacement of Front Tires

1. Removing front tires

Follow the steps below to remove the front tires:

[1] Loosen the bolts.

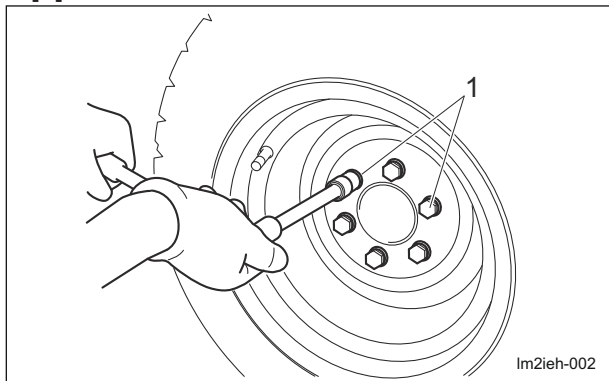

Replacement of Front Tires_001

1	Heat-treated bolt
---	-------------------

[2] Securely place the jack beneath the jack-up point of the front left/right frame area, and then raise it until the tire lifts off the ground.

"Jack-Up Points" (Page 6-2)

[3] Remove the bolts.

[4] Remove the tire from the wheel mounting seat.

2. Installing front tires

Important

Tighten the bolts in the tightening order (diagonally).

Important

Tighten the wheel mounting bolts on the specified torque by using a torque wrench.

For installing the front tires, reverse the removing procedure.

Replacement of Rear Tires

1. Removing rear tires

Follow the steps below to remove the rear tires:

[1] Loosen the bolts.

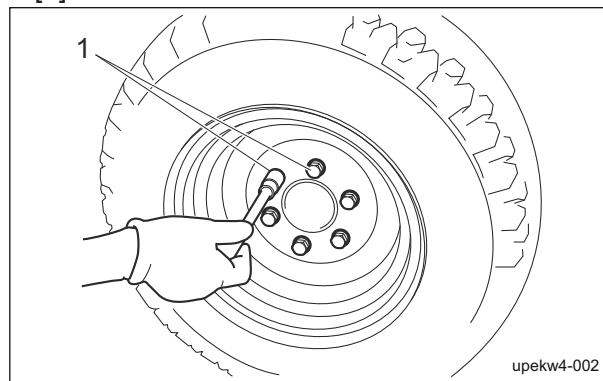

Replacement of Rear Tires_001

1	Bolt
---	------

[2] Securely place the jack beneath the jack-up point of the rear frame area, and then raise it until the tire lifts off the ground.

"Jack-Up Points" (Page 6-2)

[3] Remove the bolts.

[4] Remove the tire from the wheel mounting seat.

2. Installing rear tires

Important

Tighten the bolts in the tightening order (diagonally).

Important

Tighten the wheel mounting bolts on the specified torque by using a torque wrench.

For installing the rear tires, reverse the removing procedure.

Adjustment of Belt Tension

Warning

Be sure to stop the engine before adjusting the belts.

Important

For the specified value of belt tension, refer to Adjusted Values.
Before making sure of belt tension, rotate the belt several times.

Adjustment of Fan Belt

Warning

Be sure to stop the engine before inspecting or adjusting the fan belt.

Warning

If a cover is removed due to inspection or adjustment, be sure to reinstall it in its original location.

Important

A slacking or damaged fan belt will cause overheating or lack of battery charge.
Adjust or replace the belt.

For fan belt adjustment, follow either of the methods below.

1. Adjustment on the basis of belt slack deviation when applying a specified load to a specified place

- [1] Press the middle of the belt with your finger to check the belt tension.
The belt tension is appropriate when the belt slacks by approximately 10.0 mm (0.39 in) when you apply a force of 98 N (10 kgf) to the belt at the middle point between the pulleys.

- [2] If the belt tension is incorrect, loosen bolt A, nut and bolt B for securing the alternator, and then move the alternator to adjust the tension.

- [3] Be sure to tighten bolt A, nut and bolt B securely after adjustment.

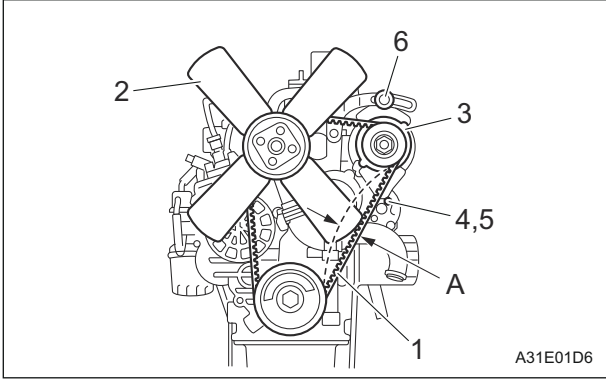

Adjustment of Fan Belt_001

1	Fan Belt
2	Blade
3	Alternator
4	Bolt A
5	Nut
6	Bolt B
A	10 mm (0.39 in)

- 2. Adjustment to suitable belt tension force by using sonic type tension meters at a specified point

Important

Perform correct measurement in accordance with the operations manual of the equipment being used for tension measurement.

Important

Perform measurement immediately after mounting the belt, when the pulley is not rotating.

- [1] Measure belt tension force by using a sonic type tension meter.
For measurement position and distance between pulleys, see diagram below.
Here is the suitable belt tension force.

Adjustment	200 – 300 N (20.39 - 30.59 kgf)
Replacement	267 – 361 N (27.23 - 36.81 kgf)

- [2] If the belt tension is inappropriate, loosen bolt A, nut and bolt B for securing the alternator, and then move the alternator to adjust the tension.

Maintenance

Maintenance

[3] Be sure to tighten bolt A, nut and bolt B securely after adjustment.

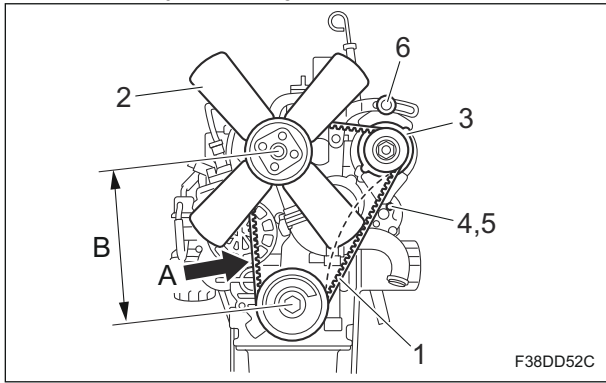

Adjustment of Fan Belt_002

1	Fan belt
2	Blade
3	Alternator
4	Bolt A
5	Nut
6	Bolt B
A	Measurement position
B	Distance between pulleys

3. Set the knife rotation lever to the "Rotation" position, and then press the middle of the belt with your finger to check the belt tension.

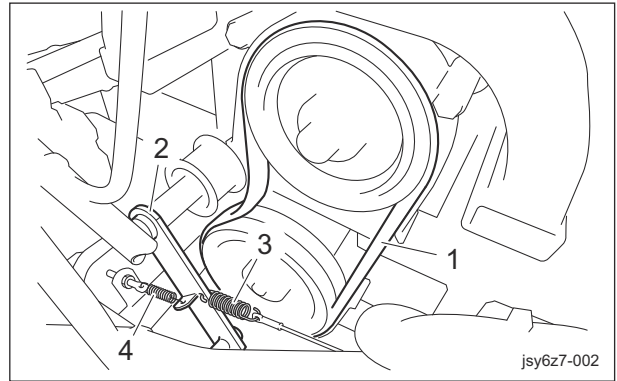

Knife Tension Belt_002

1	Knife tension belt
2	Tension lever
3	Tension spring
4	Tension return spring

Knife Tension Belt

1. Remove the rear cover.
2. Set the knife rotation lever to the "Rotation" and "Stop" positions, and check the following points.
 - The tension lever operates correctly.
 - The spring stretches appropriately.

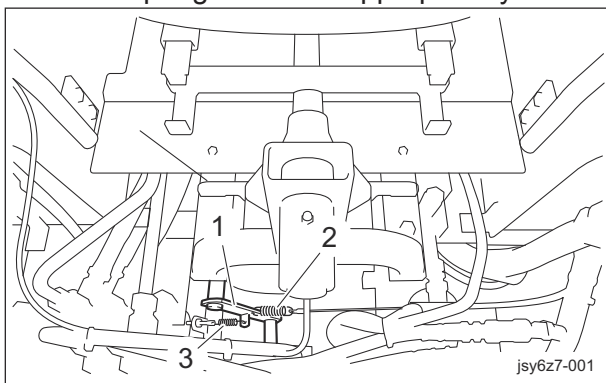

Knife Tension Belt_001

1	Tension lever
2	Tension spring
3	Tension return spring

4. If the belt tension is inappropriate, adjust it by tightening the tension wire adjustment bolt. Adjust it so that the springs are adjusted as follows.

- Tension spring
Set the knife rotation lever to the "Rotation" position, and then adjust so that the total length of the tension spring is 40.0 mm (1.57 in).

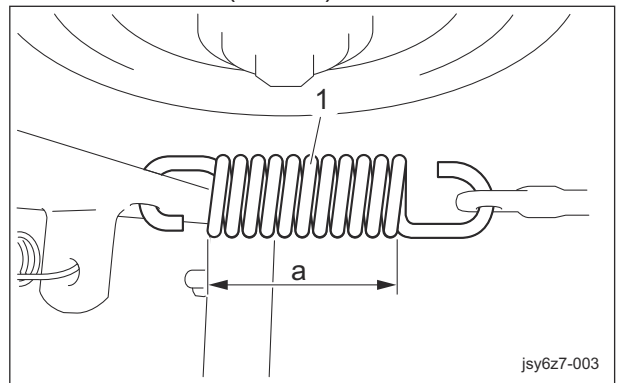

Knife Tension Belt_003

1	Tension spring
a	40.0 mm (1.57 in)

• Tension return spring

Important

Make sure that the shoe of the knife brake is not worn.
If the brake shoe is worn, replace it.

Important

After adjusting the knife brake, adjust the tension return spring.

Set the knife rotation lever to the "Stop" position, and then adjust so that the total length of the tension return spring is 50.0 mm (1.97 in).

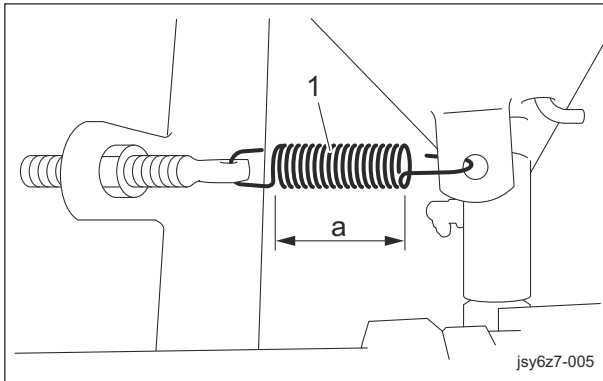

Knife Tension Belt_004

1	Tension return spring
a	50.0 mm (1.97 in)

Change of Coolant

Caution

Do not touch the radiator or coolant during engine operation or immediately after the engine has been turned off. Otherwise, you may get burned.

Caution

Change coolant after the engine has well cooled down.

Caution

The radiator cap is pressurized. If you remove the radiator cap while the engine is overheated, hot steam will burst out, possibly resulting in burns. Make sure that the water temperature and pressure are reduced, and then grab the cap with a thick cloth and gradually open the cap.

Important

When changing the coolant, be sure to drain it into a container and discard it in accordance with local laws and regulations.

Important

When changing the coolant, be sure to mix clean water and antifreeze (long-life coolant), and then pour it into the radiator and reserve tank.

Important

Tightly close the radiator cap. If the cap is loose or incorrectly installed, the engine will be overheated due to water leakage, resulting in engine damage.

When mixing antifreeze and clean water, refer to "Relationship between concentration of long-life coolant (LLC) and freezing temperature" below for the mixing ratio.

Relationship between concentration of long-life coolant (LLC) and freezing temperature

Freezing temperature	LLC concentration (volume %)
Down to -10 °C (14 °F)	20 %
Down to -15 °C (5 °F)	30 %
Down to -20 °C (-4 °F)	35 %
Down to -25 °C (-13 °F)	40 %

1. Stop the engine, and then allow the radiator to cool.
2. Open the hood.
3. Follow the steps below to drain the coolant.
 - [1] Position a container to drain the coolant into.

Maintenance

[2] Remove the drain plug from the radiator.

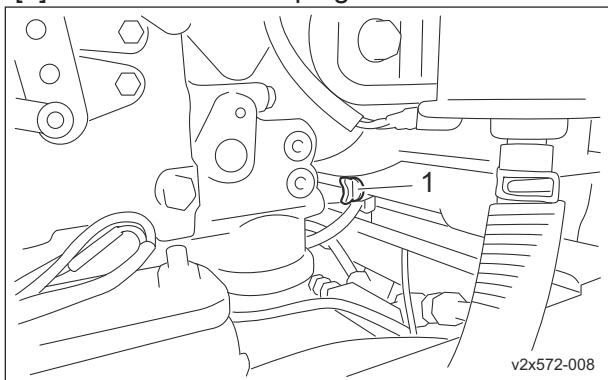

Change of Coolant_001

1	Radiator drain plug
---	---------------------

[3] Remove the radiator cap.

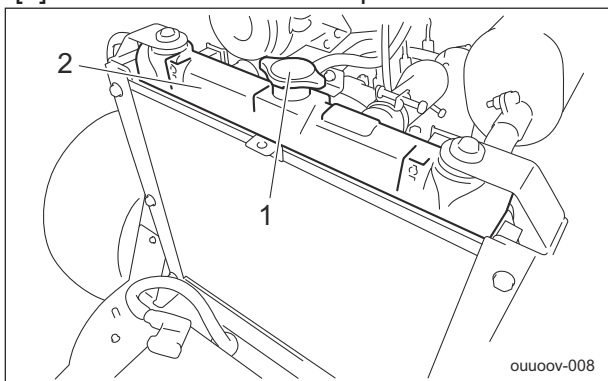

Change of Coolant_002

1	Radiator cap
2	Radiator

[4] Remove the reserve tank.

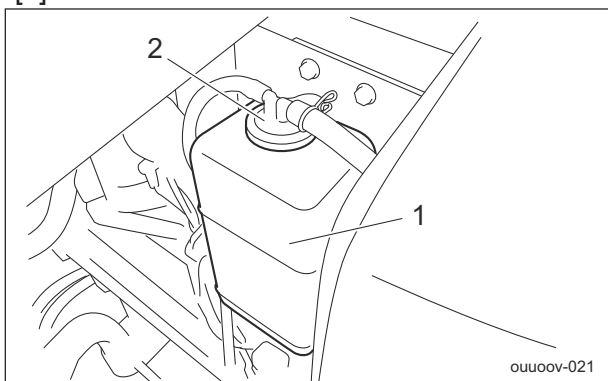

Change of Coolant_003

1	Reserve tank
2	Reserve tank cap

[5] Open the reserve tank cap, and then drain the coolant.

4. Install the reserve tank.
5. Clean the radiator with clean water to remove any debris or rust.
6. Drain all water from the radiator.

7. Follow the steps below to fill with coolant. The coolant quantity, including the reserve tank, is 6.0 dm³ (6.0 L).

- [1] Install the drain plug.
- [2] Supply clean water and antifreeze into the radiator up to the radiator cap opening.
- [3] Close the radiator cap.
- [4] Supply clean water and antifreeze into the reserve tank up to the "FULL" mark.
- [5] Close the reserve tank cap.
8. Start the engine, and then idle for several minutes to bleed air from the system.
9. Stop the engine, and then allow the radiator to cool.
10. Check if the coolant level in the reserve tank is between "FULL" and "LOW", and then supply coolant if necessary.
11. Close the hood.

Replacement of Hydraulic Oil

Caution

Be careful with hot oil, which could cause burns if it contacts your skin.

Important

When you change the hydraulic oil, be sure to drain it into a bowl and discard it in accordance with local laws and regulations.

Important

If the oil emulsifies or if it becomes even slightly less transparent, change the oil immediately.

Important

For the hydraulic oil to be used, consult Characteristics of Hydraulic Oil and use the oil whose characteristics are equivalent or superior to those specified there. Especially regarding kinematic viscosity and viscosity index, use of hydraulic oil whose figures are less than those of the specified hydraulic oil will cause a malfunction in the hydraulic circuit.

Characteristics of Hydraulic Oil

ISO Viscosity Grade		ISO VG46
Density	15 °C (59 °F)	0.873 g/cm ³ (0.0315 lb/in ³)
API Gravity		30.6
Flash Point (Open Cup)		230 °C (446 °F)
Pour Point		-30 °C (-22 °F)
Kinematic Viscosity	40 °C (104 °F)	46 mm ² /s (46 cSt)
	100 °C (212 °F)	7 mm ² /s (7 cSt)
Viscosity Index		109

Note:

In Japan, "Shell Tellus S2M46" meets the characteristics described above.

However, in other countries, the specification of Shell Tellus S2M46 can be below what is required.

Please check the product data sheet to ensure that it meets the requirements before using.

1. Follow the steps below to remove the old oil.

- [1] Start and run the engine to warm up the oil.
- [2] On a level surface, lower the mower decks, and then stop the engine.
- [3] Remove the drain plug of the hydraulic tank, and then drain the old oil into a container.
- [4] Wind new sealing tape on the drain plug, and then attach it to the hydraulic tank.

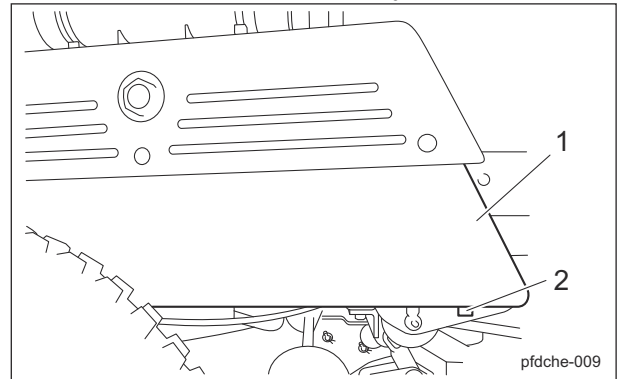

Replacement of Hydraulic Oil_001

1	Hydraulic tank
2	Drain plug

2. Follow the steps below to supply new oil.

The hydraulic tank capacity is approximately 22.0 dm³ (22.0 L).

■ #20001-21255

- [1] Open the tank cap.
- [2] Supply hydraulic oil through the oil filling port until the oil level reaches the middle of the oil gauge on the hydraulic tank.
- [3] Tighten the tank cap securely.

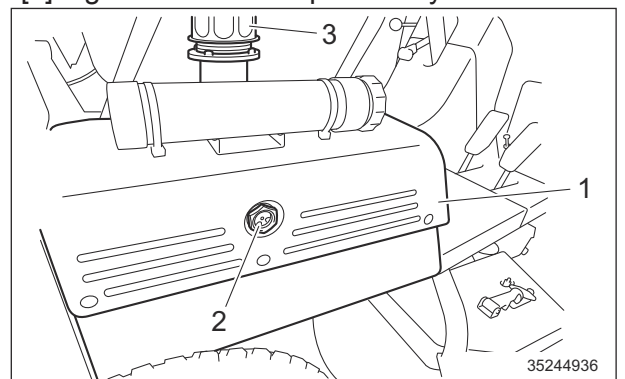

Replacement of Hydraulic Oil_002

Maintenance

Maintenance

1	Hydraulic tank
2	Oil gauge
3	Tank cap

■ #21256-

- [1] Loosen the bushing with a wrench and remove the oil filler plug.
- [2] Supply hydraulic oil through the oil filling port until the oil level reaches the middle of the oil gauge on the hydraulic tank.
- [3] Install the oil filler plug and tighten the bushing securely.

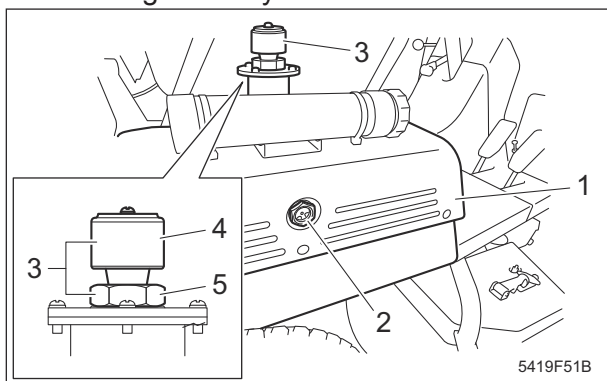

Replacement of Hydraulic Oil_003

1	Hydraulic tank
2	Oil gauge
3	Oil filler plug
4	Air breather
5	Bushing

3. Start the engine, and then repeat the steps below a few times.
 - Raise and lower the mower units.
 - Turn the steering wheel left and right.
 - Move forward and reverse.
4. Lower the mower decks and maintain that position on a level surface, and then check to see if the oil level is at the middle of the oil gauge. If necessary, supply oil.
5. Check underneath the machine for oil leakage.

Replacement of Hydraulic Oil Filter

Replacement of Hydraulic Oil Line Filter

⚠ Caution

Be careful with hot oil, which could cause burns if it contacts your skin.

Important

When replacing the hydraulic oil filter, be sure to drain the oil into a container and discard it in accordance with local laws and regulations.

Important

If the hydraulic oil emulsifies or if it becomes even slightly less transparent, change the oil immediately.

Important

Use hydraulic oil whose specification meets the requirements.

1. Move the machine onto a level surface and stop the engine.
2. Remove the bolt fixing the filter guard and then the filter guard.
3. Remove the old filter cartridge.

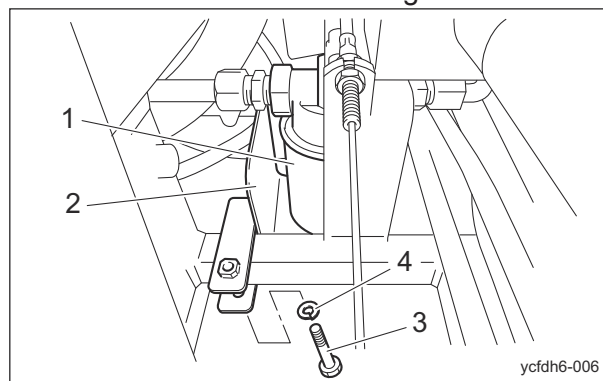

Replacement of Hydraulic Oil Line Filter_001

1	Hydraulic oil filter
2	Filter guard
3	Bolt
4	Spring washer

4. Lightly coat the packing of the new filter cartridge with hydraulic oil, and then install the cartridge.
5. Screw in the filter cartridge by hand until the packing contacts the mounting surface. Then tighten additional 1/2 turn from that point.
6. Supply hydraulic oil until it reaches the specified level.
"Supply of Hydraulic Oil" (Page 5-8)
7. Start the engine, and then stop it after 10 to 20 minutes.

8. Make sure that there is no oil leakage at the sealing surface of the filter cartridge.
9. Check the hydraulic oil level.
If it is low, supply hydraulic oil until it reaches the specified level.
10. Check underneath the machine for oil leakage.
11. Install the filter guard.

1	Element
2	Top cover
3	Seal washer
4	Screw

5. Install the new element.

Important

If the seal washer is damaged, replace it with a new one.

6. Install the top cover of the air breather.
7. Install the seal washer and tighten the screw.

Replacement of Air Breather Element

Caution

Be careful with hot oil, which could cause burns if it contacts your skin.

#21256-

1. Lower the mower decks and stop the engine on a flat surface.
2. Loosen the air breather screw and remove the seal washer.

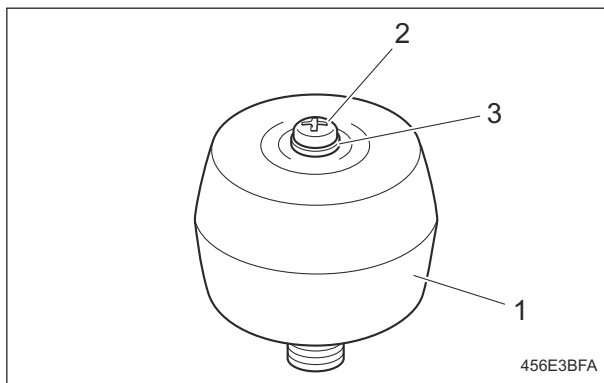

Replacement of Air Breather Element_001

1	Air breather
2	Screw
3	Seal washer

3. Remove the top cover of the air breather.
4. Remove the old element.

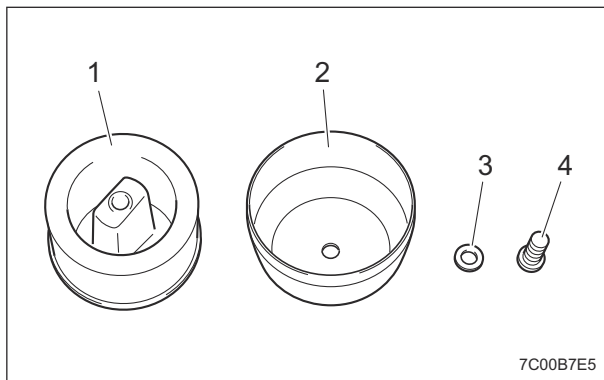

Replacement of Air Breather Element_002

Replacement of Air Cleaner Element

Important

A contaminated air cleaner element may cause malfunction of the engine.

1. The timing for replacing the air cleaner element is described below.
 - [1] Replace the air cleaner element in accordance with the Maintenance Schedule.
 - [2] If it is significantly contaminated, replace it, even if the hours of operation do not exceed the specified time.
2. Replace the air cleaner element by following the same steps as for cleaning the air cleaner. "Cleaning of Air Cleaner" (Page 5-9)

Maintenance

Change of Engine Oil

⚠ Caution

Be careful with hot oil, which could cause burns if it contacts your skin.

Important

When you change the engine oil, be sure to drain it into a bowl and discard it in accordance with local laws and regulations.

Important

Be sure to use engine oil that is classified as API Service Grade CF or higher, with an SAE Viscosity that is appropriate for the operating environment (ambient temperature).

Important

Securely tighten the oil level gauge and oil filler cap.

Change the engine oil more frequently if the engine oil is contaminated, and especially if you use the machine in dusty areas or operate the engine at high loads or in high temperatures.

1. Move the machine onto a level surface, stop the engine, remove the drain plug while the engine oil is warm, and then drain the oil into a bowl.
2. Re-place the drain plug in the engine.

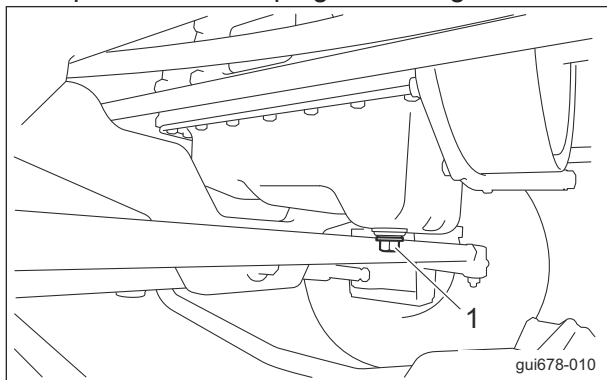

Change of Engine Oil_001

1	Drain plug
---	------------

3. Through the oil filling port, supply new engine oil until the oil reaches a level in between the upper and lower limit lines on the oil level gauge.
Engine oil quantity is approximately 3.0 dm³ (3.0 L).
4. Re-place the oil filler cap.

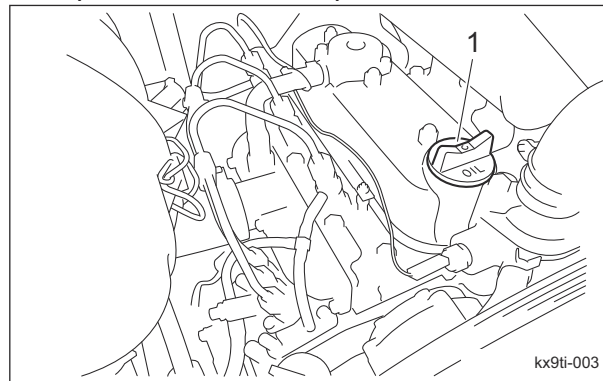

Change of Engine Oil_002

1	Oil filler cap
---	----------------

5. It will take a while for the supplied engine oil to descend into the oil pan.
Check the oil level again 10 to 20 minutes after supplying the oil.
6. Check underneath the machine for oil leakage.

Replacement of Engine Oil Filter

Caution

Be careful with hot oil, which could cause burns if it contacts your skin.

Important

When replacing the engine oil filter, be sure to drain the engine oil into a container and discard it in accordance with local laws and regulations.

Important

Be sure to use engine oil that is classified as API Service Grade CF or higher, with an SAE Viscosity that is appropriate for the operating environment (ambient temperature).

Important

Securely tighten the oil level gauge and oil filler cap.

1. With the filter wrench, remove the old filter cartridge.

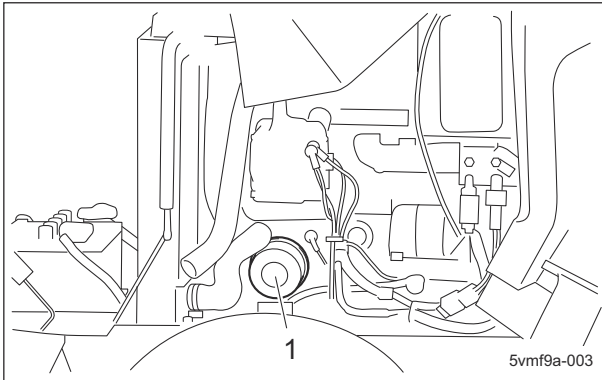

Replacement of Engine Oil Filter_001

1	Filter cartridge
---	------------------

2. Lightly coat the packing of the new filter cartridge with engine oil.
3. Hand-tighten the filter cartridge until the packing contacts the sealing surface, and then firmly hand-tighten (without using a filter wrench).
4. Supply engine oil until it reaches the specified level.
"Supply of Engine Oil" (Page 5-14)
5. Start the engine, and then stop it after 10 to 20 minutes.

6. Make sure that there is no oil leakage at the sealing surface of the filter cartridge.
7. Check the engine oil level.
If it is low, supply engine oil until it reaches the specified level.

Replacement of Fuel Filter Element

If dust or dirt accumulates in the fuel filter, the fuel flow will become insufficient. Replace the fuel filter at the appropriate times. The fuel filter is on the right side under the hood.

1. Close the fuel cock of the fuel filter.

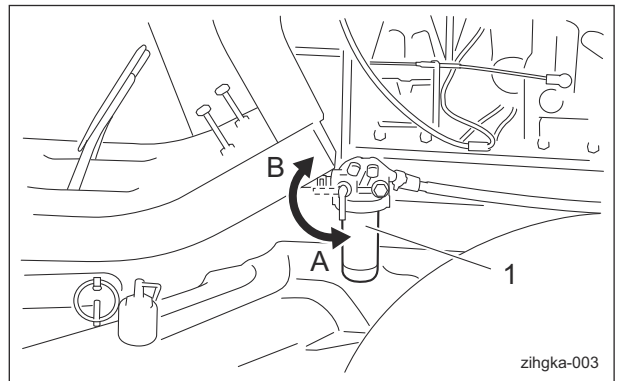

Replacement of Fuel Filter Element_001

1	Fuel filter
A	ON (open)
B	OFF (close)

2. Remove the ring nut, and then remove the cup.

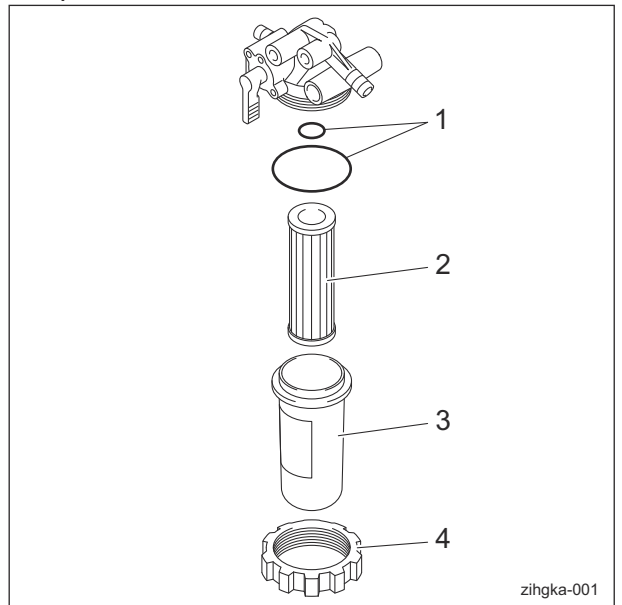

Replacement of Fuel Filter Element_002

Maintenance

1	O-ring
2	Element
3	Cup
4	Ring nut

3. Clean the inside of the filter cup with diesel fuel.

Important

During installation, prevent contamination with dirt or dust.

If the fuel is contaminated with dirt or dust etc., the fuel injection pump and injection nozzle will become worn.

4. Install a new fuel filter element, and then correctly install all parts in their original positions.

5. Fill up the fuel tank with fuel, and then open the fuel cock.

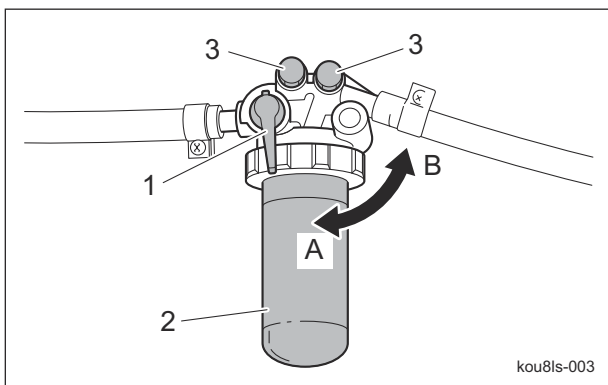

Replacement of Fuel Filter Element_003

1	Fuel cock
2	Fuel filter
3	Air-bleeding plug
A	ON (open)
B	OFF (close)

Note:

Air bleeding is not required since it occurs automatically.

Change of Transmission Oil

Caution

Be careful with hot oil, which could cause burns if it contacts your skin.

Important

When you change the transmission oil, be sure to drain it into a bowl and discard it in accordance with regional laws and regulations.

Important

Be sure to pour automobile gear oil that is classified as SAE Viscosity Grade #90 into the transmission.

1. Change the entire transmission oil after 50 hours of operation for the first time, and then change it every year.

Transmission oil quantity is 0.45 dm³(0.45 L).

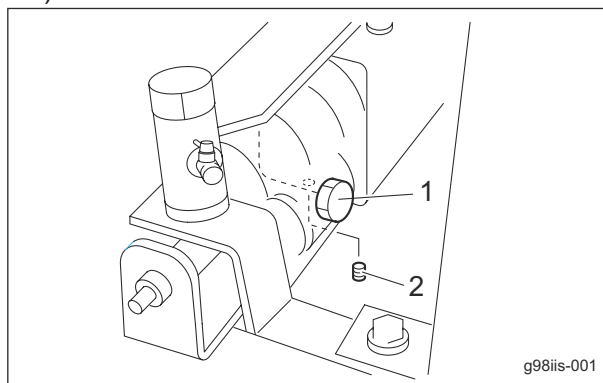

Change of Transmission Oil_001

1	Oil filling port
2	Drain plug

2. Make sure that oil does not bleed from mating areas of the gear box.
3. Check underneath the machine for oil leakage.

Storage

Long-Term Storage

Follow the instructions below for long-term storage of the machine.

1. Cleaning
 - Remove dirt, grass clippings, oil stains etc. completely from the main vehicle and engine.
2. Replacing oil
 - Inspect and replace the engine oil, hydraulic oil and element.
3. Greasing and lubricating
 - Supply oil and apply grease to appropriate parts.
4. Battery
 - Remove the negative battery wire.
5. Fuel
 - Remove the fuel from the fuel tank.
6. Tire pneumatic pressure
 - Set the tire air pressure slightly higher than normal, and then place the machine on a board to avoid humidity.
7. Mower decks
 - When storing this machine, lower all the mower decks unless a positive mechanical lock is provided.
8. Storage location
 - Cover the machine and store it in a dry place where it will not be exposed to rain.

Precautions for Repair Page 7-2

Adjustment and Replacement Page 7-2

Adjustment of Brake Page 7-2

Adjustment of Knife Brake Page 7-3

Adjusting the Neutral Position of the
Piston Pump Page 7-3

Replacement of Fuse Page 7-5

TowingPage 7-6

Towing the Machine in an
EmergencyPage 7-6

Repair

Precautions for Repair

Warning

The chapter "Repair" in this manual describes practical measures which should be performed by a mechanic with expertise. The owner should instruct the mechanic with expertise to perform repair service for this machine.

Caution

First, learn well the operations you plan to perform.

Important

Use tools appropriate for each operation.

Important

Use Baronsess genuine parts for replacement and accessories.
Our product warranty may be void if you use non-genuine parts for replacement or accessories.

Adjustment and Replacement

Adjustment of Brake

Caution

If the brake wire becomes broken, the machine will be unable to stop.
If there are cracks, damage or other defects, replace it immediately.
Adjust the brake wire if the brakes become less effective.

Important

Adjust the brake wire so that there is minimal play with the brake lever, and so that the brakes do not drag when the brake is released.

- Adjust the foot brake by tightening the adjustment bolt on the brake wire.
 - Braking force will decrease if there is more play with the brake lever, and the brake pedal will feel lighter.

- Reducing play with the brake lever will increase braking force and make the brake pedal feel heavier.

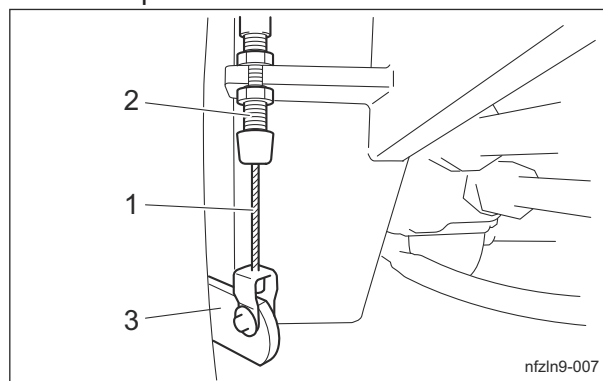

Adjustment of Brake_001

1	Brake wire
2	Adjustment bolt
3	Brake lever

- Start the engine and drive to check the following.
 - Make sure that heat is not generated in the brake area.
 - Make sure that the left and right brakes are equally effective.

Caution

It may result in an unexpected accident if the left and right brakes are not equally effective.

- If the left and right brakes are not equally effective, make fine adjustments with the adjustment bolt on the brake wire.

Break-In of Brakes

If the brake shoes or brake pads are worn, replace them with new ones.
Immediately after replacement, drive to break in the brakes if the effectiveness of the brakes is low.
While driving, lightly operate the brakes to break in the contact areas.

Adjustment of Knife Brake

1. Remove the rear cover.
2. Make sure that the knife rotation lever is set to the "Stop" position.

Important

Make sure that the shoe of the knife brake is not worn. If the brake shoe is worn, replace it.

Important

After adjusting the knife tension spring, adjust the knife brake.

3. Loosen the bolts mounting the brake shoe.

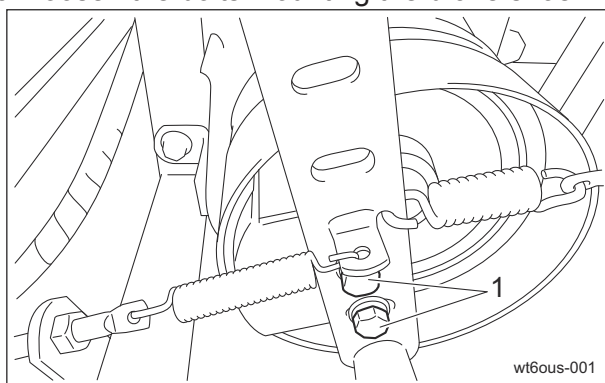

Adjustment of Knife Brake_001

1	Bolt
---	------

4. Move the brake shoe to the position where it is flush against the inside of the pulley drum.

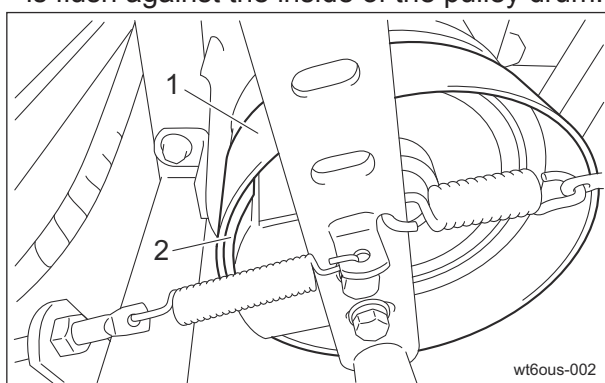

Adjustment of Knife Brake_002

1	Pulley drum
2	Brake shoe

5. Tighten the bolt mounting the brake shoe.
6. Adjust the knife tension return spring.
7. Install the rear cover.
8. Start the engine.

9. Set the knife rotation lever to the "Rotation" position.
10. Make sure that the rotary knife rotates, and then set the knife rotation lever to the "Stop" position and make sure that the rotary knife stops rotating within 7 seconds.

Adjusting the Neutral Position of the Piston Pump

Caution

Make sure not to touch rotating tires.

If the machine moves forward or backward while the traveling pedals are released, they are not set to the neutral position. Follow the steps below to make adjustments.

1. Stop the engine.
2. Place the jacks beneath the jack-up points, and then lift the machine off the ground. Use stable jack stands, and raise the machine until the tires lift off the ground. "Jack-Up Points" (Page 6-2)
3. Remove the seatback cover on the right side.
4. Remove the underseat cover on the right side.
5. Start the engine, and rev it up to the maximum rpm.
6. Set the 2WD/4WD selector switch to the "4WD" position.
7. Adjust the neutral position for the rear wheels.

- [1] If the rear tires rotate forward, loosen the cam lever shaft, and then adjust lock nuts A to move the shaft seat backward. Find the position where the rear wheels stop, and then tighten the cam lever shaft to secure it.
- [2] If the rear tires rotate in reverse, loosen the cam lever shaft, and then adjust lock nuts A to move the shaft seat forward. Find the position where the rear wheels stop, and then tighten the cam lever shaft to secure it.

Repair

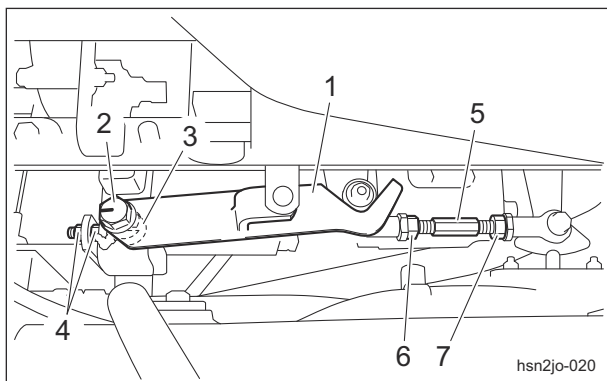

Adjusting the Neutral Position of the Piston Pump_001

1	Cam lever
2	Cam lever shaft
3	Shaft seat
4	Lock nut A
5	Threaded rod
6	Lock nut B (right-hand screw)
7	Lock nut C (left-hand screw)

1	Cam lever
2	Cam lever shaft
3	Shaft seat
4	Lock nut A
5	Threaded rod
6	Lock nut B (right-hand screw)
7	Lock nut C (left-hand screw)

Important

Before adjusting the neutral position for the front wheels, make sure that the rear wheels have first been set to the neutral position.

8. Adjust the neutral position for the front wheels.

[1] If the front tires rotate forward, loosen lock nuts B and C of the threaded rod, then turn the threaded rod to shorten the connection.

Find the position where the front wheels stop, and then tighten lock nuts B and C.

[2] If the front tires rotate in reverse, loosen lock nuts B and C of the threaded rod, then turn the threaded rod to extend the connection.

Find the position where the front wheels stop, and then tighten lock nuts B and C.

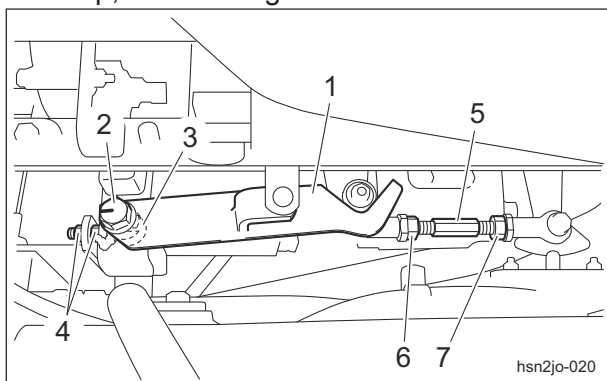

Adjusting the Neutral Position of the Piston Pump_002

Replacement of Fuse

Important

When performing maintenance on the electrical system, be sure to remove the negative battery wire.

Important

If a fuse blows, a short may have occurred within the electrical circuit. Check for the cause, such as faulty terminal connections, damaged wiring or terminals, or incorrect wiring.

Important

For fuse replacement, clean the fuse mounting area with use of compressed air before mounting the fuse.

Fuse Box

The fuse box includes spare fuses and tools.

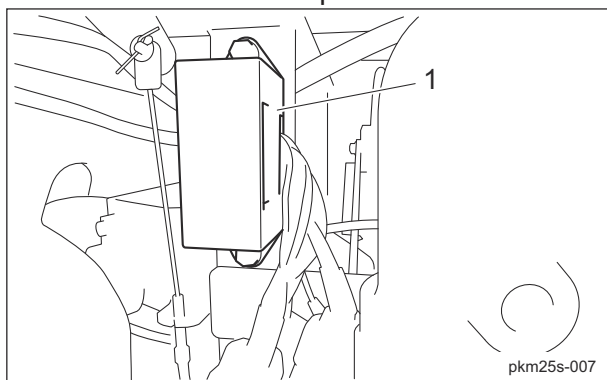

Fuse Box_001

1	Fuse box
---	----------

The machine uses a mini fuse for automobiles. Replace an old fuse with a new fuse of the specified capacity.

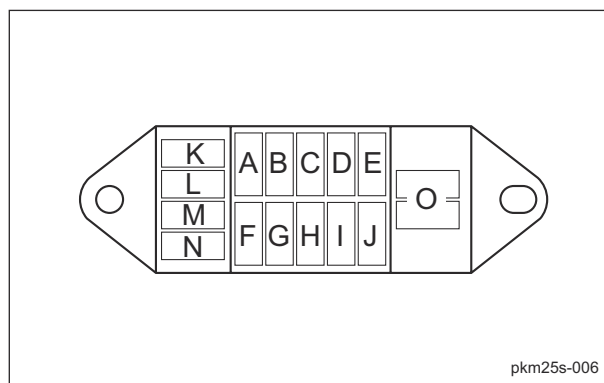

Fuse Box_002

A	5A	Timer (glow signal)
B	5A	Glow lamp
C	5A	Fuel pump
D	5A	Water temperature gauge, charge lamp, oil pressure (engine oil pressure) lamp, water temperature buzzer
E	15A	Electromagnetic valve
F	-	-
G	5A	Timer (start signal)
H	5A	Alternator
I	5A	Fuel SOL relay
J	5A	Starter relay, Delay timer, Sitting detection relay, Neutral detection relay
K	5A	Spare
L	5A	
M	15A	
N	15A	
O		Tool

Fusible Link

Fuse capacity of the fusible link is described below.

- Engine stop solenoid: 30 A
- Battery: 50 A

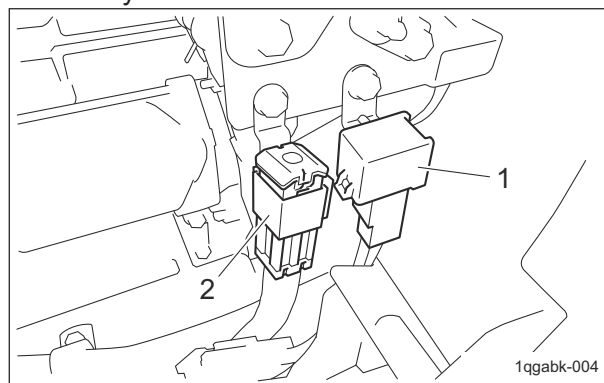

Fusible Link_001

Repair

1	Fusible link (engine stop solenoid)
2	Fusible link (battery)

Towing

Towing the Machine in an Emergency

If the machine does not travel due to engine trouble, etc., you can move it in the following ways.

- Pushing by hand
- Towing (See the following instruction.)

⚠ Caution

Before towing, make sure that the brake applies effectively.

Important

Do not touch the unload valve except when towing the machine.

Important

Before restarting the engine, be sure to close the bypass.

Important

When towing the machine, obey the following restrictions.

Obey the speed and the time restrictions to prevent damaging the pump or motor.

- Speed: Do not travel at a speed more than 3.0 km/h.
- Time: Do not tow the machine for more than 3 minutes.

When towing the machine for more than 3 minutes, start the engine and circulate the hydraulic oil in the hydraulic circuit. Therefore, do not tow the machine until restart the engine after completed repairs.

1. Stop the engine.
"Procedure to Stop Engine" (Page 5-18)
2. Apply the parking brake.
3. Chock the wheels.

4. Apply a rope to the front wheel pivot.

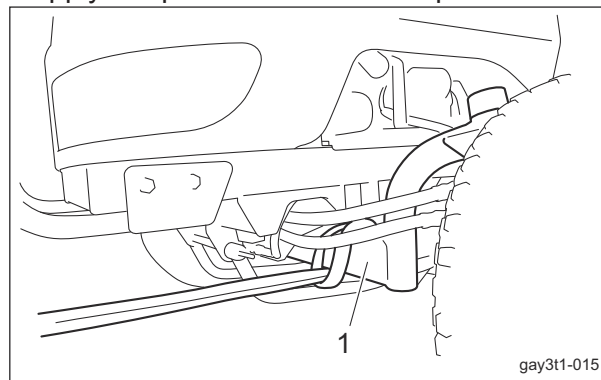

Towing the Machine in an Emergency_001

1	Front wheel pivot
---	-------------------

5. Remove the underseat cover on the right side.

Important

Do not pull out the unload valve more than 7 mm (0.28 in) by loosening it more than four turns.

6. Open the bypass.

Loosen the unload valve three to four turns counterclockwise to pull it out 5 mm (0.20 in).

- 2WD: Loosen either one of the unload valves.
- 4WD: Loosen both of the unload valves.

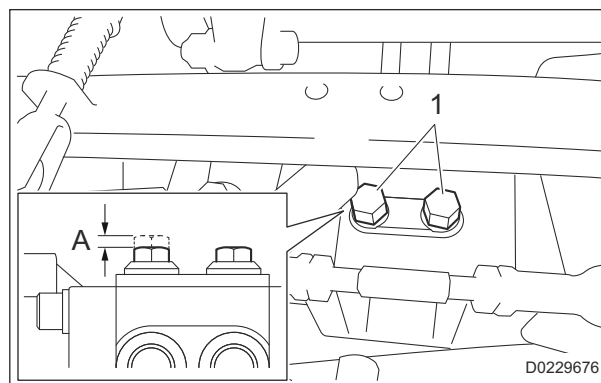

Towing the Machine in an Emergency_002

1	Unload valve
A	5 mm (0.20 in)

7. Install the underseat cover on the right side.
8. Remove the wheel stoppers.

9. Release the parking brake.

 Warning

While towing, always put your foot on the brake pedal to make sure you can depress the brake pedal immediately to stop the machine.

10. Tow the machine slowly.

Important

The tightening torque for the unload valve is 34.3 N-m (349.75 kgf-cm).

11. After towing is completed, close the bypass.
Screw in the loosened unload valve to tighten it.

Appended Table

- Tightening TorquesPage 8-2**
 - Standard Tightening TorquesPage 8-2
 - Principal Tightening Torques Page 8-5
- Maintenance Schedule Page 8-6**
- List of Adjusted Values Page 8-7**

Appended Table

Appended Table

Tightening Torques

Important

Refer to the Tightening Torque table.
Note that the Baroness product warranty may not apply to defects caused by incorrect or overtorque tightening, etc.

Standard Tightening Torques

Bolts and Nuts



Important

A number of bolts are used in each part of this machine.
Be sure to re-tighten the bolts and nuts, because they may be loosened at the earlier stage of the use.

- As to the bolts and nuts without any special instruction, tighten them in appropriate tightening torque with proper tool.
Too much tightening may cause the looseness or damage of the screw.
- The strength of tightening is determined by types of screws, strength, the friction of thread face or base face and others.
The table below is for the galvanized or parkerized bolts.
In case that the strength of internal thread is weak, it is not applied.
- Do not use rusty or sand attached "screw."
Otherwise, it may cause insufficient tightening even if you apply the specified tightening torque.
The friction of the screw face becomes higher and the tightening torque is canceled out by the friction, therefore sufficient tightening cannot be applied.
- If "screw" is wet by water or oil, do not tighten it with normal tightening torque.
If the screw is wet, the torque coefficient will get smaller and it may result in too much tightening.
Too much tightening may cause looseness by the screw stretched or result in damage.
- Do not use a bolt experienced too much burden.
- Using the impact wrench requires the skill.
Do exercise as much as possible for steady tightening.

Appended Table

Nominal diameter	General bolt		
	Strength classification 4.8		
	 tib3yb-001		
	N-m	kgf-cm	lb-in
M5	3 - 5	30.59 - 50.99	26.55 - 44.26
M6	7 - 9	71.38 - 91.77	61.96 - 79.66
M8	14 - 19	142.76 - 193.74	123.91 - 168.17
M10	29 - 38	295.71 - 387.49	256.68 - 336.34
M12	52 - 67	530.24 - 683.20	460.25 - 593.02
M14	70 - 94	713.79 - 958.52	619.57 - 831.99
M16	88 - 112	897.34 - 1142.06	778.89 - 991.31
M18	116 - 144	1,182.85 - 1,468.37	1,026.72 - 1,274.54
M20	147 - 183	1,498.96 - 1,866.05	1,301.10 - 1,619.73
M22	295	3,008.12	2,611.05
M24	370	3,772.89	3,274.87
M27	550	5,608.35	4,868.05
M30	740	7,545.78	6,549.74

Nominal diameter	Heat-treated bolt					
	Strength classification 8.8			Strength classification 10.9		
	 tib3yb-002			 tib3yb-003		
	N-m	kgf-cm	lb-in	N-m	kgf-cm	lb-in
M5	5 - 7	50.99 - 71.38	44.26 - 61.96	7 - 10	71.38 - 101.97	61.96 - 88.51
M6	8 - 11	81.58 - 112.17	70.81 - 97.36	14 - 18	142.76 - 183.55	123.91 - 159.32
M8	23 - 29	234.53 - 295.71	203.57 - 256.68	28 - 38	285.52 - 387.49	247.83 - 336.34
M10	45 - 57	458.87 - 581.23	398.30 - 504.51	58 - 76	591.43 - 774.97	513.36 - 672.68
M12	67 - 85	683.20 - 866.75	593.02 - 752.34	104 - 134	1,060.49 - 1,366.40	920.50 - 1186.03
M14	106 - 134	1,080.88 - 1,366.40	938.21 - 1,186.03	140 - 188	1,427.58 - 1,917.04	1,239.14 - 1,663.99
M16	152 - 188	1,549.94 - 1,917.04	1,345.35 - 1,663.99	210 - 260	2,141.37 - 2,651.22	1,858.71 - 2,301.26
M18	200 - 240	2,039.40 - 2,447.28	1,770.20 - 2,124.24	280 - 340	2,855.16 - 3,466.98	2,478.28 - 3,009.34
M20	245 - 295	2,498.27 - 3,008.12	2,168.50 - 2,611.05	370 - 450	3,772.89 - 4,588.65	3,274.87 - 3,982.95
M22	-	-	-	530	5,404.41	4,691.03
M24	-	-	-	670	6,831.99	5,930.17
M27	-	-	-	1,000	10,197.00	8,851.00
M30	-	-	-	1,340	13,663.98	11,860.34

Note:

The same values are applied to "fine screw thread."

Appended Table

Hydraulic Hose

The tightening torques for union joints and union adaptors with parallel pipe threads (G, PF) are shown in the table below.

A union joint or adaptor will not become loose or leak as long as it is tightened by the specified torque.

If fluid leaks from the sealed portion, do not attempt to tighten the union joint or adaptor forcibly.

Examine whether any foreign matter or scratches are present on the seat surface.

Tightening a union joint or adaptor forcibly could damage the connection of the joints.

When tightening a union joint or adaptor, use a torque wrench where possible and firmly tighten it by an appropriate torque.

Nominal diameter of the hose size	Nominal diameter of the parallel pipe threads (G, PF)	Tightening torque		
		N-m	kgf-cm	lb-in
6	1/4	25	254.93	221.28
9	3/8	50	509.85	442.55
12	1/2	60	611.82	531.06
15	3/4	120	1,223.64	1,062.12
19	3/4	120	1,223.64	1,062.12
25	1	140	1,427.58	1,239.14
32	1-1/4	170	1,733.49	1,504.67
38	1-1/2	210	2,141.37	1,858.71
50	2	250	2,549.25	2,212.75

Fittings with Parallel Threads (O-Ring Seal Type)

The tightening torques for fittings with parallel threads (O-ring seal method) are shown in the table below.

Tightening the fitting forcibly with a spanner or other such tool to secure it to a set position could damage the fitting, its washers, and other parts.

When tightening an adjustable elbow, use a torque wrench where possible and firmly tighten it by an appropriate torque.

Nominal diameter of thread	Tightening torque		
	N-m	kgf-cm	lb-in.
1/4	34.32 - 49.03	349.96 – 499.96	303.77 – 433.96
3/8	68.65 - 78.45	700.02 – 799.95	607.62 – 694.36
1/2	98.07 - 117.68	1,000.02 – 1,199.98	868.02 – 1,041.59
3/4	147.10 - 176.52	1,499.98 – 1,799.97	1,301.98 – 1,562.38
1	245.17 - 274.59	2,500.00 – 2,799.99	2,170.00 – 2,430.40
1-1/4	294.20	2,999.96	2,603.96
1-1/2	294.20	2,999.96	2,603.96
2	392.27	3,999.98	3,471.98

Appended Table

Principal Tightening Torques

Tightening Torque by Model

GM1700_Main vehicle

Tighten the following bolts and nuts at the torque specified in the table.

For thread locking adhesive, apply a middle strength thread locker (ThreeBond 1322 or equivalent anaerobic sealant).

Location		Code	Part name	Tightening torque			Thread locking adhesive
				N-m	kgf-cm	lb-in	
Front wheel	Wheel mounting base	K0138240002	24 slotted nut high P1.5	180 - 200	1,835.46 - 2,039.40	1,593.18 - 1,770.20	-
	Wheel	K0011120302	Bolt, 11T, heat-treated M12-30P1.5	67 - 85	683.20 - 866.75	593.02 - 752.34	-
Rear wheel	Wheel mounting base	K0160000492	24 special nut P1.5	180 - 200	1,835.46 - 2,039.40	1,593.18 - 1,770.20	○
	Wheel	K0011120302	Bolt, 11T, heat-treated M12-30P1.5	67 - 85	683.20 - 866.75	593.02 - 752.34	-
Engine base		K0017100252	Bolt, 8T, heat-treated, small, 10-25 P1.25	45 - 57	458.87 - 581.23	398.30 - 504.51	-
		K0100080002	Nut, M8	29 - 38	295.71 - 387.49	256.68 - 336.34	-
Electric components for engine		-	Starter B terminal (M8)	5.9 - 11.7	60.16 - 119.30	52.22 - 103.56	-
		-	Alternator B terminal (M6)	5.9 - 9.8	60.16 - 99.93	52.22 - 86.74	-
		-	Glow plug connection terminal nut (M4)	1.0 - 1.8	10.20 - 18.35	8.85 - 15.93	-
Joint mounting bracket front		K0017100252	Bolt, 8T, heat-treated, small, 10-25 P1.25	45 - 57	458.87 - 581.23	398.30 - 504.51	-
Joint mounting bracket rear		K0010100201	Bolt, heat-treated M10-20	58 - 76	591.43 - 774.97	513.36 - 672.68	-
Joint shaft housing		K0010080302	Bolt, 11T, heat-treated M8-30	14 - 19	142.76 - 193.74	123.91 - 168.17	-
Kingpin stopper		K0010120602	Bolt, 11T, heat-treated M12-60	Nut 52 - 67	530.24 - 683.20	460.25 - 593.02	-
Tie rod		K1610000020	Tie rod end right ass'y slotted nut	45	458.87	398.30	-
		K1611000020	Tie rod end left ass'y slotted nut	45	458.87	398.30	-
ROPS		K0010120402	Bolt, HT M12-40	104 - 134	1,060.49 - 1,366.40	920.50 - 1,186.03	-
		K0010120502	Bolt, HT M12-50	104 - 134	1,060.49 - 1,366.40	920.50 - 1,186.03	-

Appended Table

Maintenance Schedule

GM1700 (Main vehicle)

● . . . Inspect, adjust, supply, clean (first time)

○ . . . Inspect, adjust, supply, clean

▲ . . . Replace (first time)

△ . . . Replace

Maintenance Item		Before work	After work	Every 8 hrs.	Every 10 hrs.	Every 50 hrs.	Every 100 hrs.	Every 200 hrs.	Every 250 hrs.	Every 300 hrs.	Every 400 hrs.	Every 500 hrs.	Every year	Every 2 years	Every 3 years	Every 4 years	Remarks	
Engine	Tightening the parts	○																
	Fuel	○																
	Fuel and oil leaks	○																
	Engine oil	○		▲		△												
	Engine oil filter	○				▲	△											
	Radiator	○																
	Coolant	○				△												
	Fan belt	○												△				
	Battery	○													△			
	Battery fluid	○																
	Cleaning the exterior		○															
Main vehicle	Tightening the parts	○																
	Interlock system	○																
	Electrical wiring												○					
	Greasing, oiling					○												
	Tire	○																
	V-belt	○											△					
	Clutch (knife rotation lever)	○																
	Brake	○																
	Knife Brake	○																
	Wire	○							△									
	Cover	○																
	Liquid leakage	○																
	Hydraulic oil	○						▲					△					
	Hydraulic oil filter							▲					△					
	Air breather element							▲					△					#21256-
	Transmission oil	○				▲								△				
	Hydraulic hose (moving part)	○													△			
Hydraulic hoses (Moving part) relating to steering														△				
Hydraulic hose (fixed part)	○															△		

Appended Table

Maintenance Item		Before work	After work	Every 8 hrs.	Every 10 hrs.	Every 50 hrs.	Every 100 hrs.	Every 200 hrs.	Every 250 hrs.	Every 300 hrs.	Every 400 hrs.	Every 500 hrs.	Every year	Every 2 years	Every 3 years	Every 4 years	Remarks
Main vehicle	Air cleaner	○						△					△				Refer to "Change of Air Cleaner" Every 200 hours or every year whichever comes earlier
	Fuel strainer	○					○						△				
	Fuel pipe	○															
	Cleaning the exterior		○														

- For engine maintenance, refer to the Engine's Owner's Manual.
- The values for consumables are not guaranteed.
- Be sure to replace hydraulic hoses for steering cylinder and hydraulic hoses for hydraulic motor of wheel relating to steering every two years.

List of Adjusted Values

Fan belt	10 mm (0.39 in)	Slack when applying 98 N (10 kgf) force to the belt at the middle point
	Adjustment: 200 - 300 N (20.39 - 30.59 kgf) Replacement: 267 - 361 N (27.23 - 36.81 kgf)	Measurement of belt tension by using a sonic type tension meter
Knife tension belt	40.0 mm (1.57 in)	Total length of tension spring (with knife rotation lever in "Rotation" position)
	50.0 mm (1.97 in)	Total length of tension return spring (with knife rotation lever in "Stop" position)

Appended Table

Appended Table

Maintenance RecordsPage 9-2

Records

Records

Maintenance Records

GM1700 (Main vehicle)

Use this table freely for your records of the maintenance.

Model		Serial Number	
-------	--	---------------	--

Items										
Engine	Tightening the parts									
	Fuel									
	Fuel and oil leaks									
	Engine oil									
	Engine oil filter									
	Radiator									
	Coolant									
	Fan belt									
	Battery									
	Battery fluid									
	Cleaning the exterior									

Records

Items											
Main vehicle	Tightening the parts										
	Interlock system										
	Electrical wiring										
	Greasing, oiling										
	Tire										
	V-belt										
	Clutch (knife rotation lever)										
	Brake										
	Knife Brake										
	Wire										
	Cover										
	Liquid leakage										
	Hydraulic oil										
	Hydraulic oil filter										

Records

Records

Items											
Main vehicle	Air breather element										
	Transmission oil										
	Hydraulic hose (moving part)										
	Hydraulic hoses (Moving part) relating to steering										
	Hydraulic hose (fixed part)										
	Air cleaner										
	Fuel strainer										
	Fuel pipe										
	Cleaning the exterior										

BARONESS[®]
Quality on Demand

 **KYOEISHA CO., LTD.**
Head Office 1-26, Miyuki-cho, Toyokawa-city, Tel :+81-533-84-1390
Aichi-pref, 442-8530 JAPAN Fax:+81-533-84-1220