

GM1700

Contour Deck for GM1700

Parts catalog

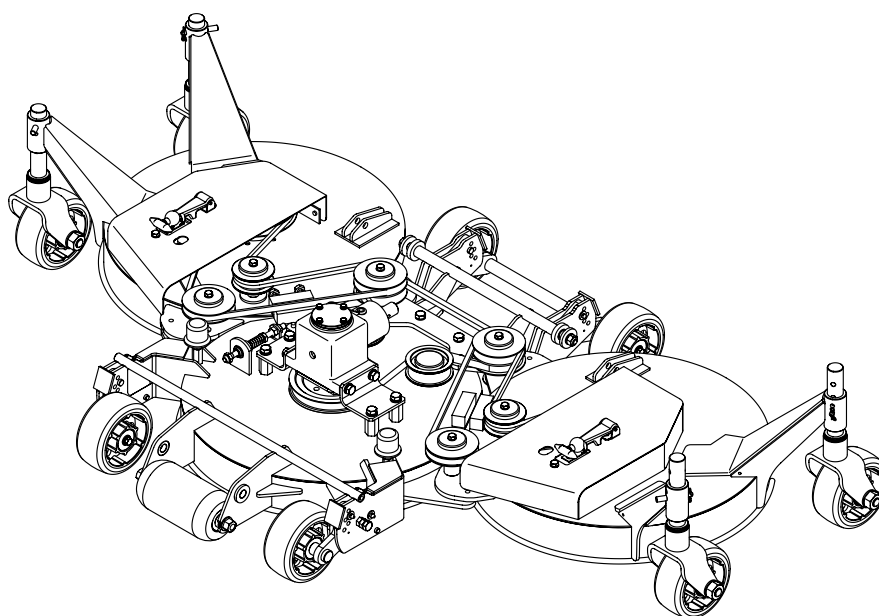

BARONESS[®]
Quality on Demand

Greetings

Thank you for purchasing Baroness product.

This brochure contains the information needed for ordering BARONESS parts.

Search the number indicating the figure of your desired part in the illustration area, and find the same number from among the latter parts of the hyphenated Cat Nos. in the listing area to obtain the individual Code No.

Notes

1) For inquiries of parts

Inform us of the model and the serial number of your machine or attachment.

The model and the serial number are indicated on the serial number plate of your machine or attachment.

* Consult the Owner's Operating Manual for the position where the serial number plate is affixed.

2) For ordering parts

- Inform us of the Code No., Part name and order quantity.
- We do not accept returns unless our company is responsible for the issue.
- Use genuine Baroness parts and accessories. The Baroness product warranty may not apply if parts or accessories from other companies are used.

3) The information described in this brochure is subject to change without prior notice.

Description of the content of Parts catalog

1) Illustration area

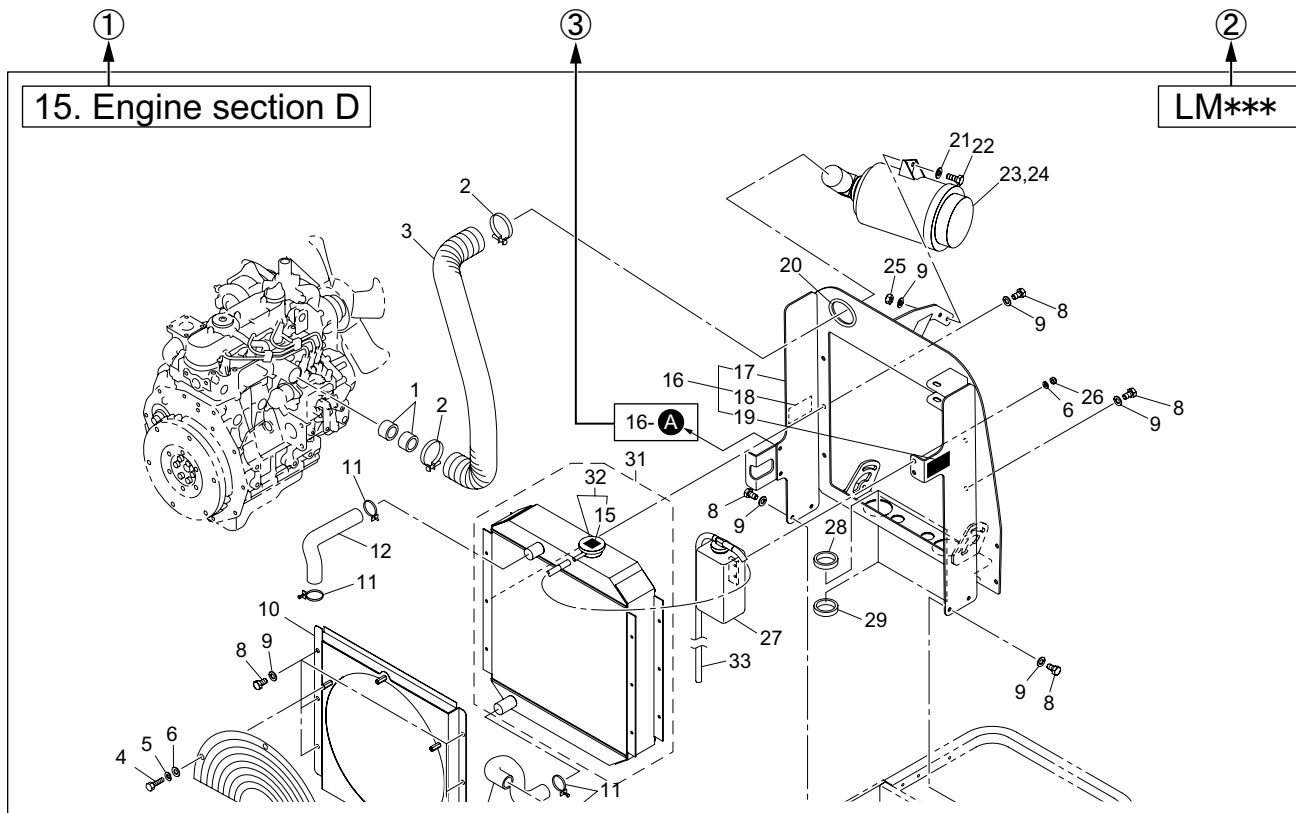

- ① Section No. /Section name
- ② Model
- ③ Indication of the connecting point

The following indication shows the connecting point of the part shown on the other page.

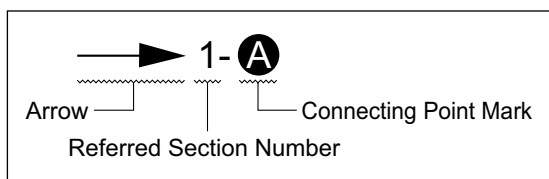

- 1- **A** :
Refer to the point **A** in the illustration of the section No.1
- 2- **B** :
Refer to the point **B** in the illustration of the section No.2

Note :

The figures of assembled components or isolated parts do not always show their accurate shapes. The figures are supposed to be used for obtaining the correct code numbers.

2) Listing area

Cat No.	Code No.	Part name	Qty			Remark	SN of application
1 - 1	K0000080152	BOLT, M8-15	2	2	2		
1 - 2	K0185160002	NUT, LEFT-HANDED P1.5 M16-3	2	2	2		
1 - 3	K3650000100	HOUR METER, HH2AS	1	1	1		10001-10023
1a- 3	K3650000130	HOUR METER, 636DC	1	1	1		10024-
1 - 4	K0100060002	NUT, M6	2	2	2		
1 - 5	K0003080702	BOLT, M8-70	1	1	1		
1 - 7	K0830000020	OIL SEAL, 254210	2	2	2		

① Cat No. or Catalog No.

Find the same number as the number indicating the figure of your desired part in the illustration area from among the latter parts of the hyphenated Cat Nos. to obtain the individual Code No.

② Code No.

Identification code of an individual part

③ Part name

④ Qty

Quantity needed per Cat No.

⑤ Model

When the quantity differs by models, the models are indicated.

⑥ Remark

Specification or description, etc. of the part may be indicated.



⑦ SN of application

In case of part alteration, the serial number ranges of machines to which the alteration is applied will be indicated.

3) Indication in case of part alteration

- When a new part and an old one are interchangeable with each other, indication of the old part code No. is discontinued and the new part code No. is solely indicated.
- When a new part and an old one are not interchangeable, the serial number ranges of both machines where the new part is used and those where the old one is used are indicated in the SN of application column.
- When a part is newly added, the serial number range of machines where the part is used is indicated in the SN of application column.
- When a part was previously used but the part is not used in the machine any longer, the serial number range of machines where the part was used is indicated in the SN of application column.

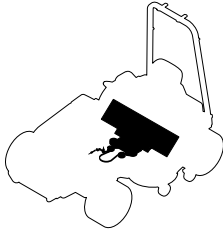
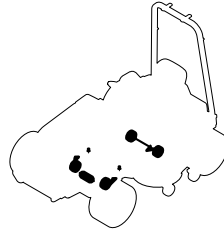
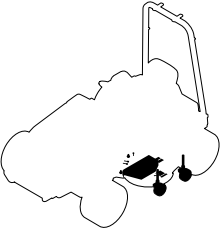
Contents

<p>A1. Connecting Parts section P1</p> 	<p>A2. Center Cutter Deck section A P3</p> 	<p>A3. Center Cutter Deck section B P5</p> 	<p>A4. Center Cutter Deck section C P7</p> 
<p>A5. Left Cutter Deck section A P9</p> 	<p>A6. Left Cutter Deck section B P11</p> 	<p>A7. Right Cutter Deck section A P13</p> 	<p>A8. Right Cutter Deck section B P15</p> 
<p>A9. Accessories P17</p>			

A1. Connecting Parts section

GM1700

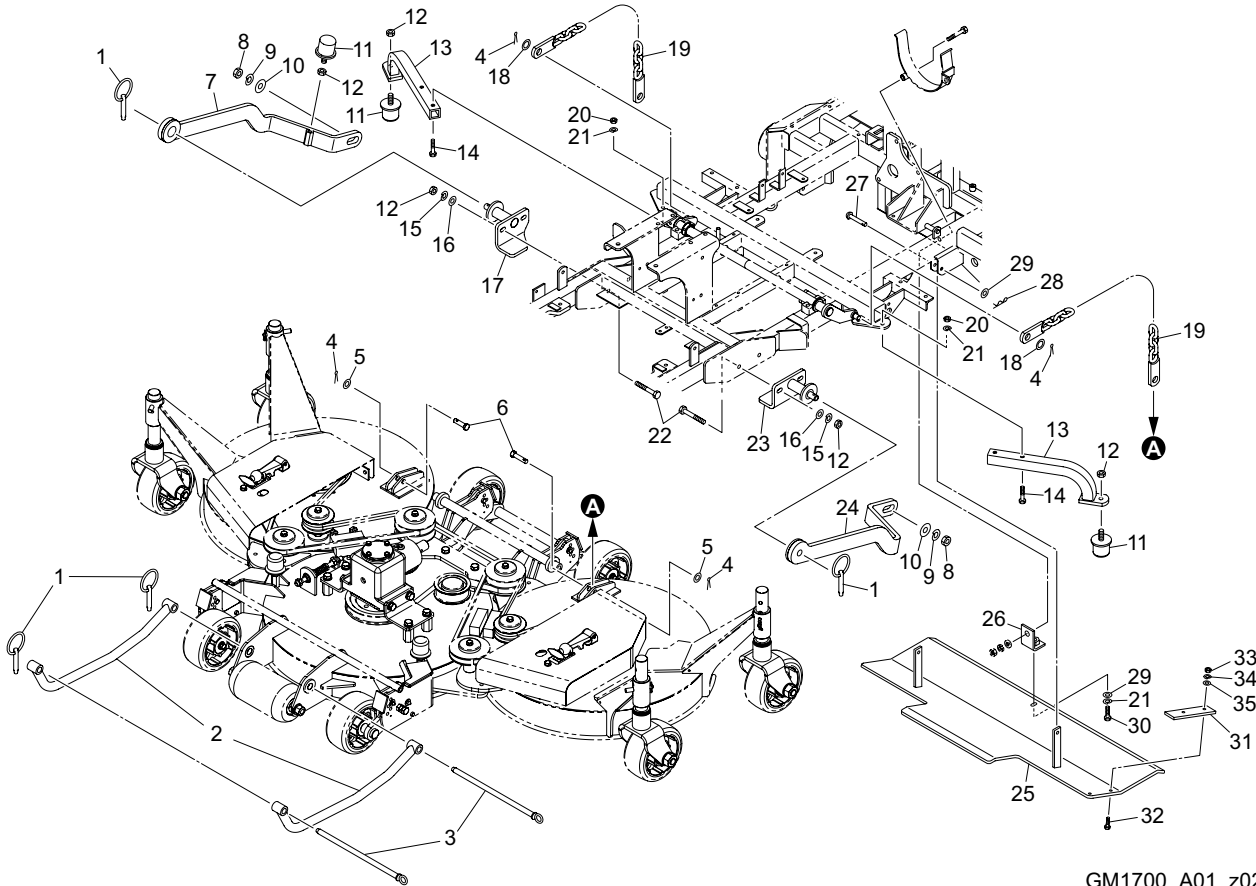

GM1700_A01_z02

Cat No.	Code No.	Part name	Qty	Remark	SN of application
A1-1	K6061060002	PIN, CLIP M6	4		
A1-2	GM1600-0611ZD	ROD, FRONT	2		
A1-3	GM1500-0605D2	PIN	2		
A1-4	K0300032252	PIN, COTTER M3.2-25	4		
A1-5	K5000120002	WASHER, M12	2		
A1-6	K6031120403	PIN, FLAT HEAD HT M12-40	2		
A1-7	GM1700-2205ZD	BAR, TOWING DECK (RH)	1		
A1-8	K0100120002	NUT, M12	2		
A1-9	K0200120002	WASHER, SPRING M12	2		
A1-10	K5076012402	WASHER, SPHC 6-12-40	2		
A1-11	K4049050000	STOPPER, RUBBER KI-50	3		
A1-12	K0100100002	NUT, M10	7		
A1-13	GM1700-2203ZD	ARM, STOPPER	2		
A1-14	K0013080502	BOLT, HT M8-50	4		
A1-15	K0200100002	WASHER, SPRING M10	4		
A1-16	K5000100002	WASHER, M10	4		
A1-17	GM1700-2202ZD	SHAFT, FULCRUM LINK (RH)	1		
A1-18	K5011014202	WASHER, SPCC 1-14-20	2		
A1-19	GM1700-2206ZD	CHAIN, LIFTING	2		
A1-20	K0100080002	NUT, M8	4		
A1-21	K0200080002	WASHER, SPRING M8	5		
A1-22	K0013100802	BOLT, HT M10-80	4		
A1-23	GM1700-2201ZD	SHAFT, FULCRUM LINK (LH)	1		
A1-24	GM1700-2204ZD	BAR, TOWING DECK (LH)	1		
A1-25	GM1700-2207ZD	COVER, DUST PROOF	1		
A1-26	GM1700-2208Z2	BRACKET, VIBRATION PROOF COVER	1		
A1-27	K6040080402	PIN, ROUND HEAD M8-40	2		
A1-28	K0330800008	PIN, SNAP M8	2		
A1-29	K5000080002	WASHER, M8	3		
A1-30	K0000080202	BOLT, M8-20	1		

A1. Connecting Parts section

GM1700

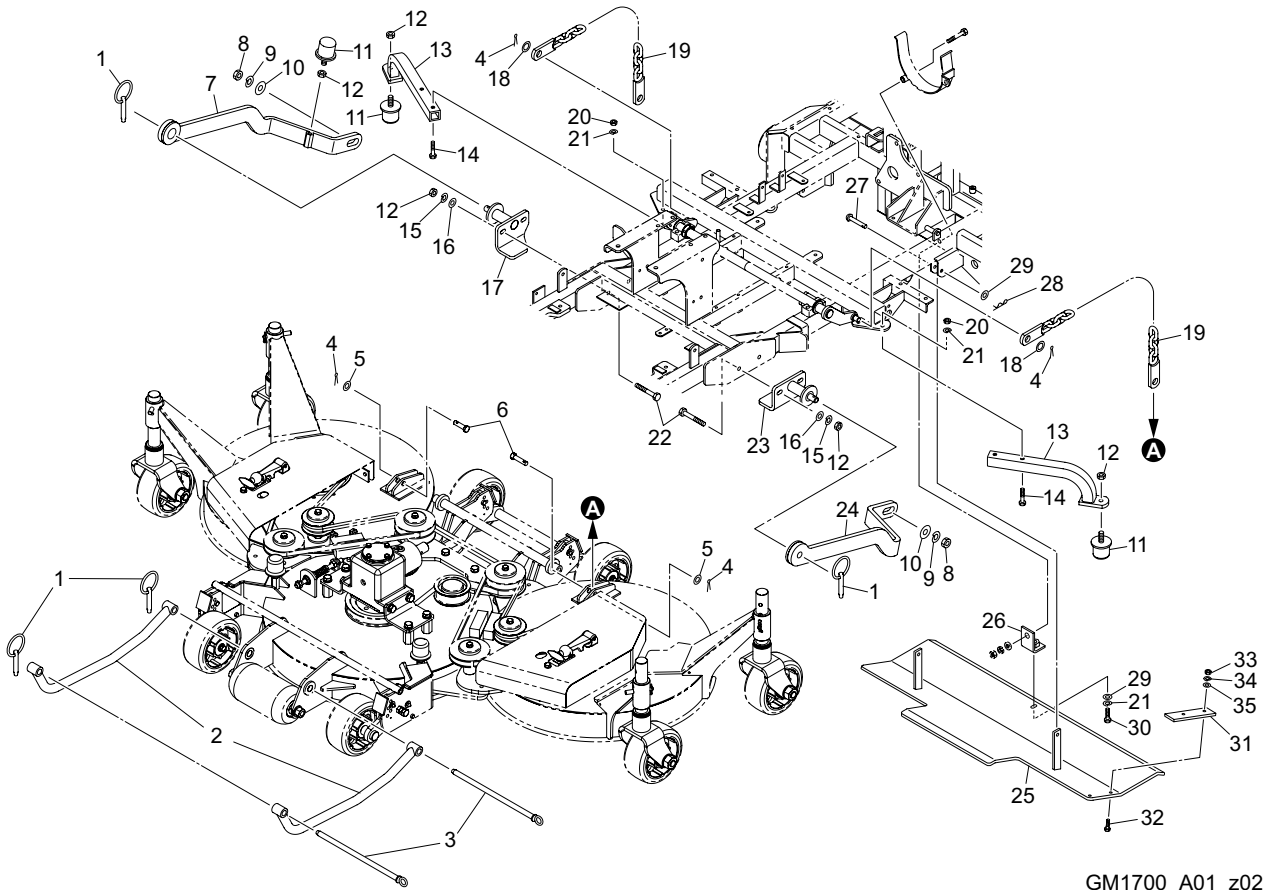

GM1700_A01_z02

Cat No.	Code No.	Part name	Qty	Remark	SN of application
A1-31	GM1700-2209Z0	APRON, RIGHT WHEEL	1		
A1-32	K0000060202	BOLT, M6-20	2		
A1-33	K0100060002	NUT, M6	2		
A1-34	K0200060002	WASHER, SPRING M6	2		
A1-35	K5012306252	WASHER, SPCC 2.3-6-25	2		

A2. Center Cutter Deck section A

GM1700

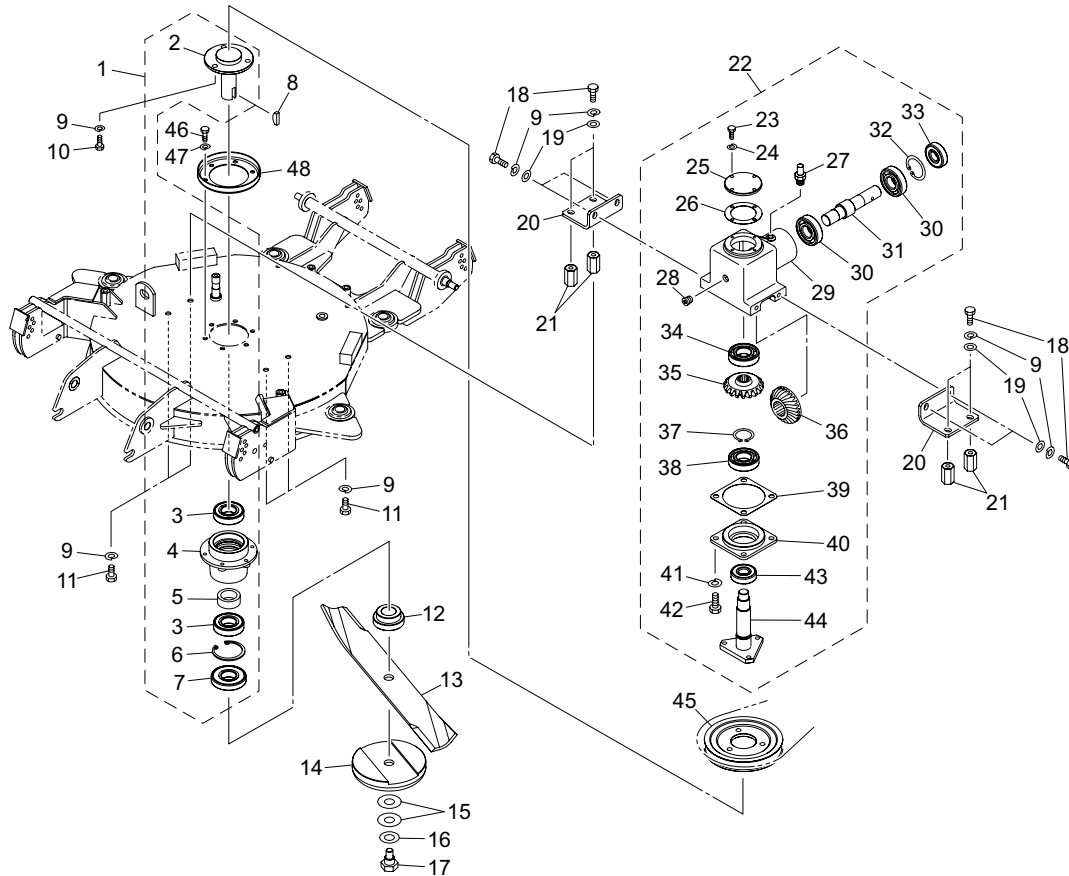

GM1700_A02_z01

Cat No.	Code No.	Part name	Qty	Remark	SN of application
A2-1	GM1500-0883Z0	HHOUSING ASSY, CENTER	1		
A2-2	GM1500-0846Z0	SHAFT, KNIFE CENTER	1		
A2-3	K0612062060	BEARING, BALL SEAL 2RD 6206	2		
A2-4	GM1500-0848A2	HOUSING, CENTER	1		
A2-5	K6212003902	COLLAR, STKM M30-40-21	1		
A2-6	K0402065001	RING, RETAINING R M65	1		
A2-7	K0825065090	OIL SEAL, MHSA50659	1		
A2-8	K0520707260	KEY, ROUND/SQUARE, M7-726.5	1		
A2-9	K0200100002	WASHER, SPRING M10	15		
A2-10	K0017100252	BOLT, SMALL HT P1.25 M10-25	3		
A2-11	K0000100202	BOLT, M10-20	4		
A2-12	GM1500-0854Z2	BRACKET, MOUNTING KNIFE	1		
A2a-13	K2530000120	BLADE, ROTARY 533L	1		
A2-14	GM1700-2150Z0	DISK, KNIFE GUARD	1		10001-10116
A2a-14					10117-
A2-15	K0211200001	SPRING, CONICAL DISC H M20	2		
A2-16	K5021020350	WASHER, NBS55 1-20-35	1		
A2-17	GM1700-2149Z1	BOLT, FIXING KNIFE	1		10001-10116
A2a-17	GM1500-0849A1	BOLT, FIXING KNIFE	1		10117-
A2-18	K0000100252	BOLT, M10-25	8		
A2-19	K5000100002	WASHER, M10	8		
A2-20	GM1500-0874A3	MOUNT, GEARBOX	2		
A2-21	GM1500-0822B2	MOUNT, BOX	4		
A2-22	GM1600-0852ZR	GEARBOX ASSY	1		
A2-23	K0000060202	BOLT, M6-20	4		
A2-24	K0200060002	WASHER, SPRING M6	4		
A2-25	GM1500-0816Z0	COVER, GEARBOX (UPPER)	1		
A2-26	GM1500-0817Z0	PACKING	1		
A2-27	K1430000022	BREATHER, AIR PT1/8	1		
A2-28	K1422106001-Y	PLUG, TAPERED W/HEX HOLE T1 3/8	1		

A2. Center Cutter Deck section A

GM1700

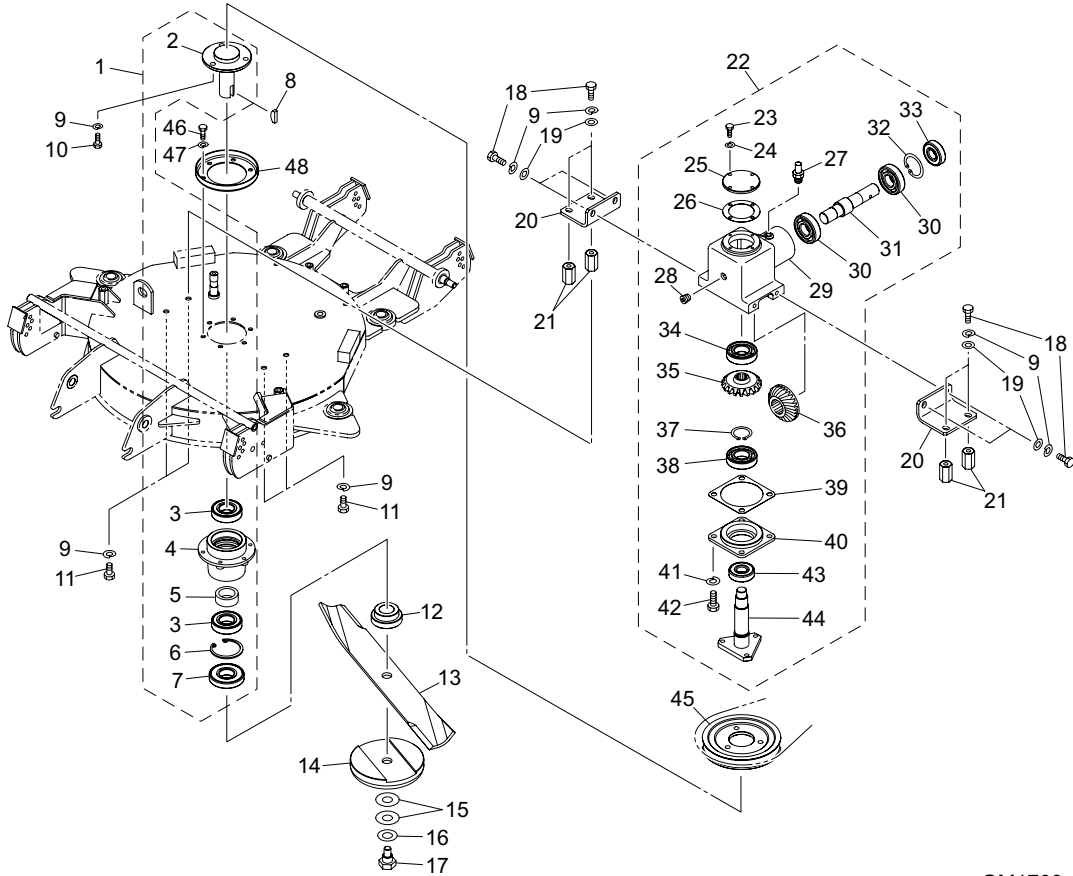

GM1700_A02_z01

Cat No.	Code No.	Part name	Qty	Remark	SN of application
A2-29	GM1600-0811Z0	GEARBOX	1		
A2-30	K0600063050	BEARING, BALL 6305	2		
A2-31	GM1600-0816Z0	SHAFT, HORIZONTAL	1		
A2-32	K0402062001	RING, RETAINING R M62	1		
A2-33	K0822562110	OIL SEAL, MHSA256211	1		
A2-34	K0617063040	BEARING, BALL SEAL 2NSE 6304	1		
A2-35	GM1600-0814Z0	GEAR, BEVEL 19-TEETH	1		
A2-36	GM1600-0813Z0	GEAR, BEVEL 24-TEETH	1		
A2-37	K0401030001	RING, RETAINING S M30	1		
A2-38	K0600062060	BEARING, BALL 6206	1		
A2-39	GM1600-0817Z0	PACKING	1		
A2-40	GM1600-0812Z0	COVER, GEARBOX	1		
A2-41	K0200100002	WASHER, SPRING M10	4		
A2-42	K0000100202	BOLT, M10-20	4		
A2-43	K0823050080	OIL SEAL, MHSA30508	1		
A2-44	GM1600-0815Z2	SHAFT, VERTICAL	1		
A2-45	GM1500-0853Z2	PULLEY, DRIVING KEY	1		
A2-46	K0000080302	BOLT, M8-30	6		
A2-47	K0200080002	WASHER, SPRING M8	6		
A2-48	K5300000352	COVER	1		

A3. Center Cutter Deck section B

GM1700

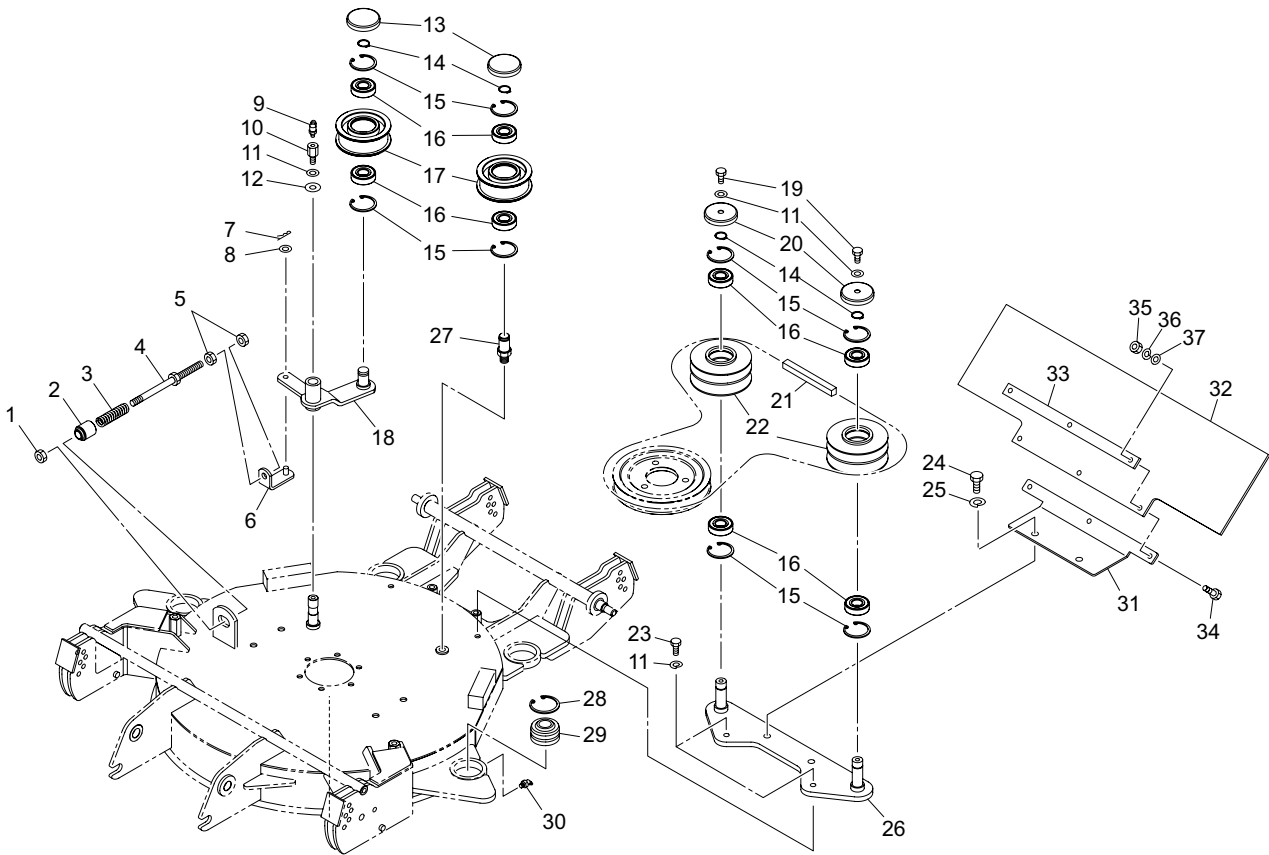

GM1700_A03_z01

Cat No.	Code No.	Part name	Qty	Remark	SN of application
A3-1	K0144100002	NUT, W/F-RING M10	1		
A3-2	K6204000812	GUIDE, SPRING	1		
A3-3	K1000000048	SPRING, COMPRESSION M3.2-16.9-60	1		
A3-4	GM1700-2109Z2	ROD, TAPPED	1		
A3-5	K0100100002	NUT, M10	2		
A3-6	GM1700-2108Z2	CONNECTOR, TENSION LEVER	1		
A3-7	K0340800002	PIN, SNAP W/RETAINER M8	1		
A3-8	K5000080002	WASHER, M8	1		
A3-9	K1440000020	GREASE NIPPLE, 90 DEG TYPE C	1		
A3-10	GM1500-0827A2	BOLT, FIXING TENSION LEVER	1		
A3-11	K0200080002	WASHER, SPRING M8	5		
A3-12	K5012308242	WASHER, SPCC 2.3-8-24	1		
A3-13	GM1500-0884Z2	LID	2		
A3-14	K0401017001	RING, RETAINING S M17	4		
A3-15	K0402040001	RING, RETAINING R M40	8		
A3-16	K0612062030	BEARING, BALL SEAL 2RD 6203	8		
A3-17	GM1700-2110Z2	PULLEY, TENSION 2680	2		
A3-18	GM1700-2107Z2	LEVER, TENSION (CENTER)	1		
A3-19	K0000080152	BOLT, M8-15	2		
A3-20	GM1700-2113Z2	LID	2		
A3-21	K2374200560	BELT, COGGED LOW EDGE H-PX SB56	1		
A3-22	GM1700-2111Z2	PULLEY, CONNECTING	2		
A3-23	K0000080202	BOLT, M8-20	2		
A3-24	K0000100202	BOLT, M10-20	2		
A3-25	K0200100002	WASHER, SPRING M10	2		
A3-26	GM1700-2112Z2	BASE, CONNECTING PULLEY	1		
A3-27	GM1700-2187Z8	PIN, TENSION LH-THREAD FOR CENTER COVER	1		
A3-28	K0402042001	RING, RETAINING R M42	4		
A3-29	K1609000010	BEARING, SPHERICAL ROLLER GE20GS	4		
A3-30	K1440000030	GREASE NIPPLE, TYPE B	4		

A3. Center Cutter Deck section B

GM1700

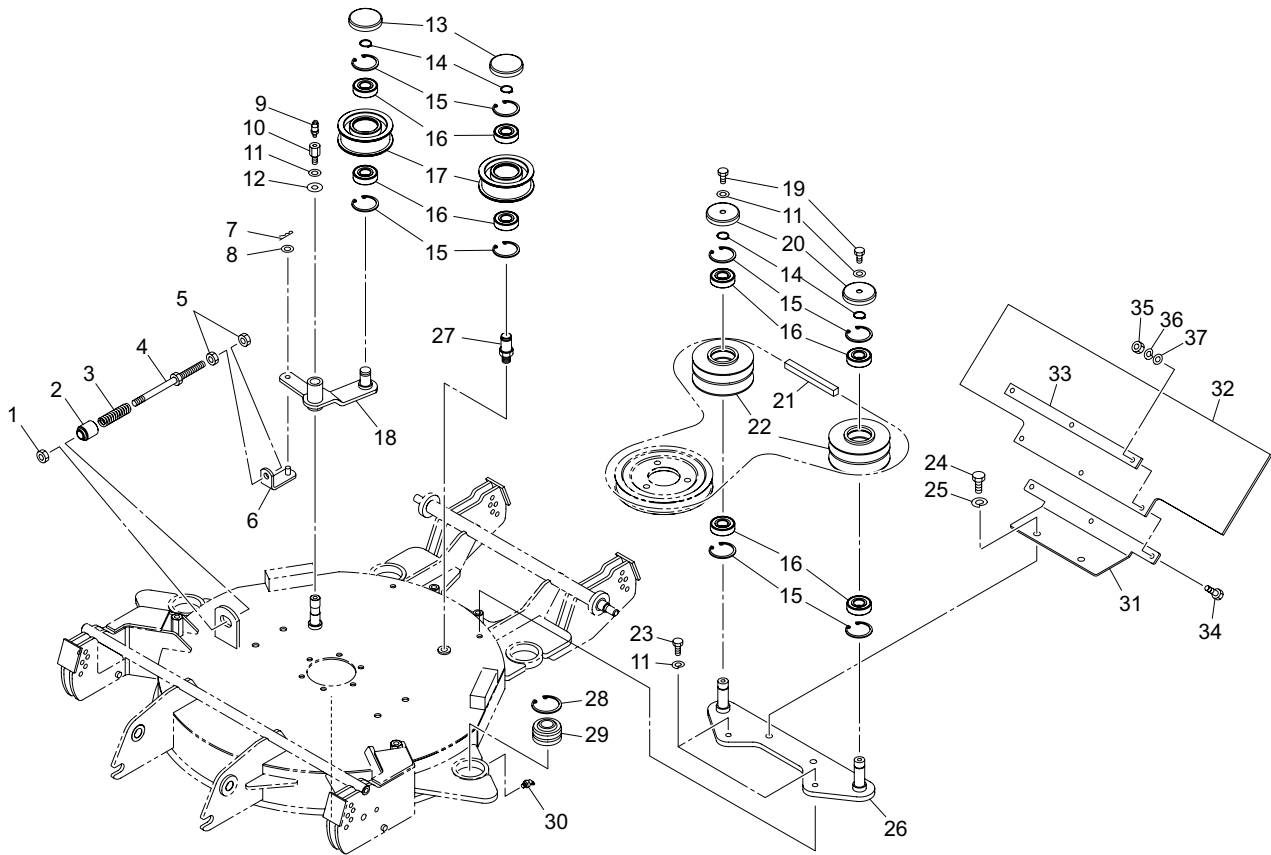

GM1700_A03_z01

Cat No.	Code No.	Part name	Qty	Remark	SN of application
A3-31	GM1700-2118ZD	PLATE, MOUNTING APRON	1		
A3-32	GM1700-2119Z0	APRON, REAR	1		
A3-33	GM1700-2117ZD	CLAMPER, DUST PROOF APRON	1		
A3-34	K0000060152	BOLT, M6-15	3		
A3-35	K0100060002	NUT, M6	3		
A3-36	K0200060002	WASHER, SPRING M6	3		
A3-37	K5000060002	WASHER, M6	3		

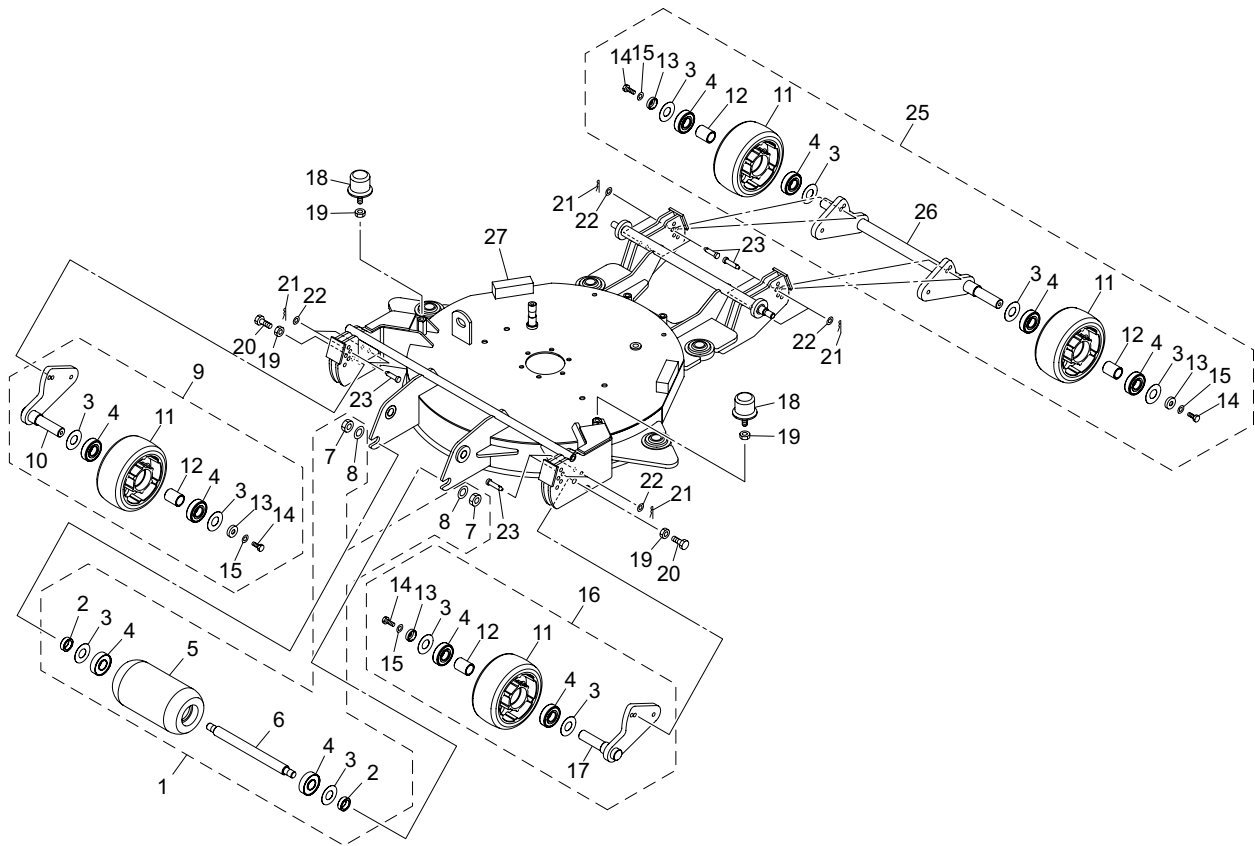

GM1700_A04_z02

Cat No.	Code No.	Part name	Qty	Remark	SN of application
A4-1	K8021000180	ROLLAR ASSY, FRONT 100	1		
A4-2	K6212000222	COLLAR, STKM M20.2-28-9	2		
A4-3	K5030520430	WASHER, C2801P 0.5-20-43	10		
A4-4	K0612062040	BEARING, BALL SEAL 2RD 6204	10		
A4-5	K6226000020	ROLLER, FRONT	1		
A4-6	K6121000132	AXLE	1		
A4-7	K0103140002	NUT, P1.5 M14	2		
A4-8	K0212140002	WASHER, DISK SPRING 1L M14	2		
A4-9	GM1700-2167Z0	CASTER WHEEL ASSY, CENTER DECK (RH)	1		20810-21327
A4a-9	GM1700-2167A0	CASTER WHEEL ASSY, CENTER DECK (RH)	1		21328-
A4-10	GM1700-2105Z2	BRACKET, WHEEL CENTER DECK (RH)	1		
A4-11	K2110000030	WHEEL, RUBBER 150	4		20810-21327
A4a-11	K2110000060	WHEEL, RUBBER 150	4		21328-
A4-12	K6212000640	COLLAR, STKM M20.2-25.4-33	4		
A4-13	K6204000212	WASHER, CLAMPING WHEEL	4		
A4-14	K0000080202	BOLT, M8-20	4		
A4-15	K0200080002	WASHER, SPRING M8	4		
A4-16	GM1700-2156Z0	CASTER WHEEL ASSY, CENTER DECK (LH)	1		20810-21327
A4a-16	GM1700-2156A0	CASTER WHEEL ASSY, CENTER DECK (LH)	1		21328-
A4-17	GM1700-2104Z2	BRACKET, WHEEL CENTER DECK (LH)	1		
A4-18	K4049050000	STOPPER, RUBBER KI-50	2		
A4-19	K0100100002	NUT, M10	4		
A4-20	K0000100252	BOLT, M10-25	2		
A4-21	K0340800002	PIN, SNAP W/RETAINER M8	8		
A4-22	K5000080002	WASHER, M8	8		
A4-23	K6031080382	PIN, FLAT HEAD HT M8.2-38	8		
A4-24					
A4-25	GM1700-2114Z0	CASTER WHEEL ASSY, CENTER DECK (REAR)	1		20810-21327
A4a-25	GM1700-2114A0	CASTER WHEEL ASSY, CENTER DECK (REAR)	1		21328-
A4-26	GM1700-2106Z2	BRACKET, WHEEL CENTER DECK (REAR)	1		

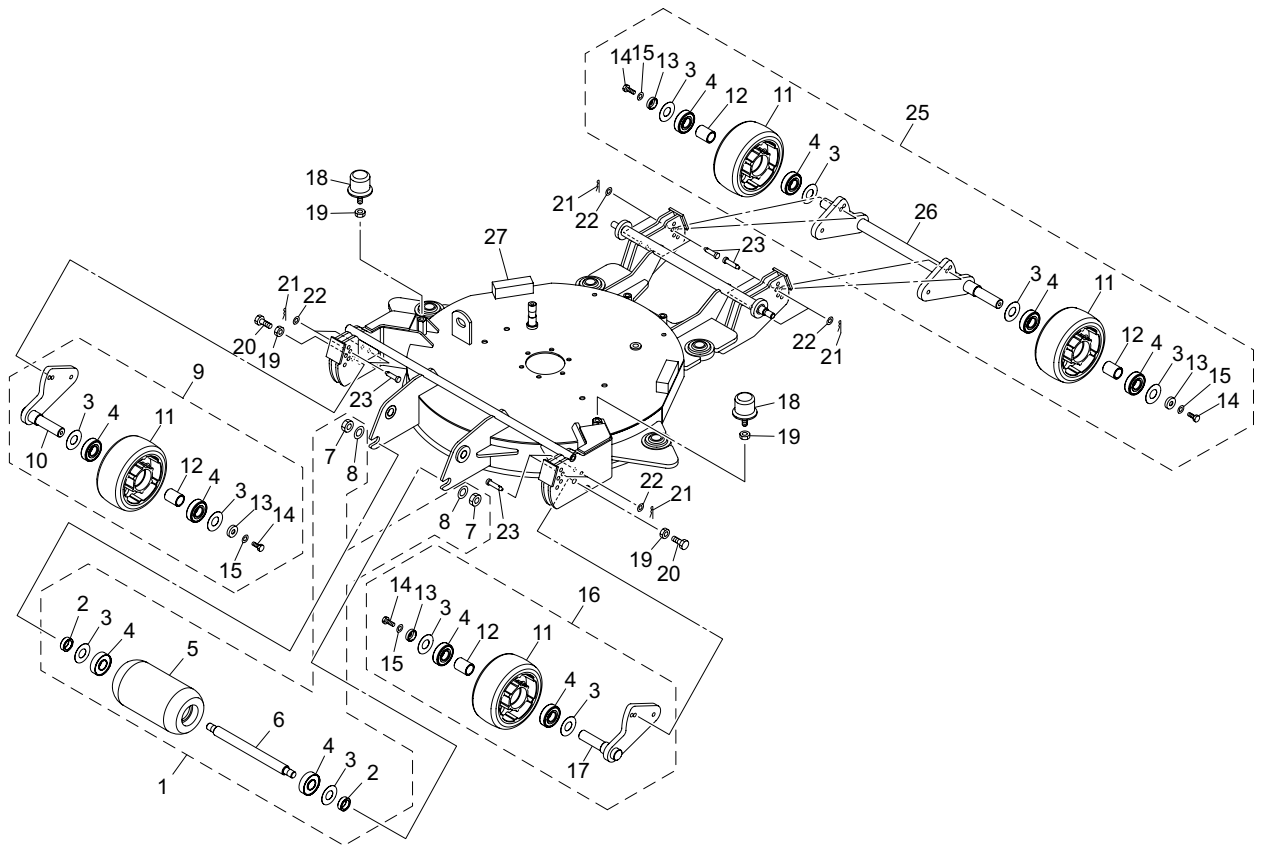

GM1700_A04_z02

Cat No.	Code No.	Part name	Qty	Remark	SN of application
A4-27	GM1700-2172ZR	COVER, ROTARY (CENTER)	1		

A5. Left Cutter Deck section A

GM1700

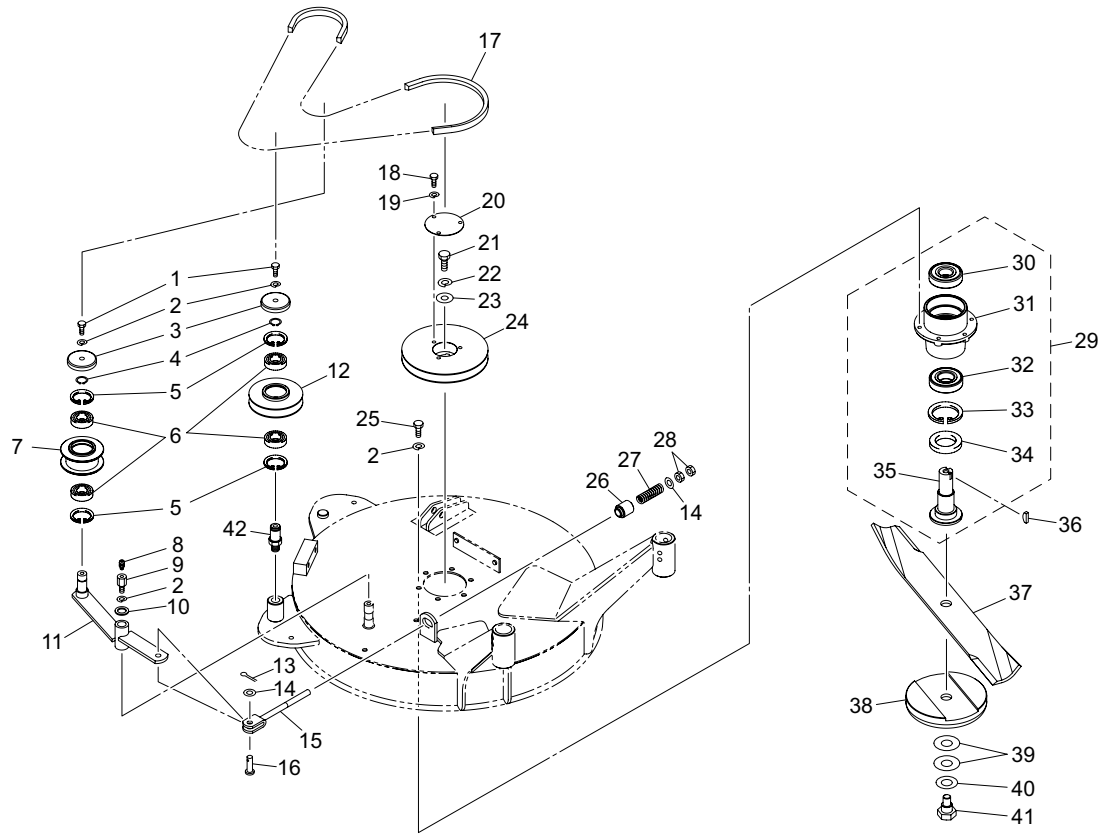

GM1700_A05_z01

Cat No.	Code No.	Part name	Qty	Remark	SN of application
A5-1	K0000080152	BOLT, M8-15	2		
A5-2	K0200080002	WASHER, SPRING M8	9		
A5-3	GM1700-2113Z2	LID	2		
A5-4	K0401017001	RING, RETAINING S M17	2		
A5-5	K0402040001	RING, RETAINING R M40	4		
A5-6	K0612062030	BEARING, BALL SEAL 2RD 6203	4		
A5-7	GM1700-2124Z2	PULLEY, TENSION 2660	1		
A5-8	K1440000010	GREASE NIPPLE, STRAIGHT TYPE A	1		
A5-9	GM1500-0827A2	BOLT, FIXING TENSION LEVER	1		
A5-10	K5012308242	WASHER, SPCC 2.3-8-24	1		
A5-11	GM1700-2122Z2	LEVER, TENSION (LH)	1		
A5-12	GM1700-2125Z2	PULLEY, COUNTER	1		
A5-13	K0300025202	PIN, COTTER M2.5-20	1		
A5-14	K5000100002	WASHER, M10	2		
A5-15	K7303000262	ROD, TENSION	1		
A5-16	K6031100258	PIN, FLAT HEAD HT M10-25	1		
A5-17	K2373100640	BELT, COGGED LOW EDGE H-PIV SA64	1		
A5-18	K0000060102	BOLT, M6-10	3		
A5-19	K0200060002	WASHER, SPRING M6	3		
A5-20	K517000012D	PLATE, SPCC BOLT COVER	1		
A5-21	K0010100252	BOLT, HT M10-25	1		
A5-22	K0200100002	WASHER, SPRING M10	1		
A5-23	K5074510422	WASHER, SPHC 4.5-10-42	1		
A5-24	GM1700-2123Z2	PULLEY, ROTARY	1		
A5-25	K0000080302	BOLT, M8-30	6		
A5-26	K6204000812	GUIDE, SPRING	1		
A5-27	K1000000048	SPRING, COMPRESSION M3.2-16.9-60	1		
A5-28	K0100100002	NUT, M10	2		
A5-29	GM1700-2142Z0	HOUSING ASSY	1		
A5-30	K0612063050	BEARING, BALL SEAL 2RD 6305	1		

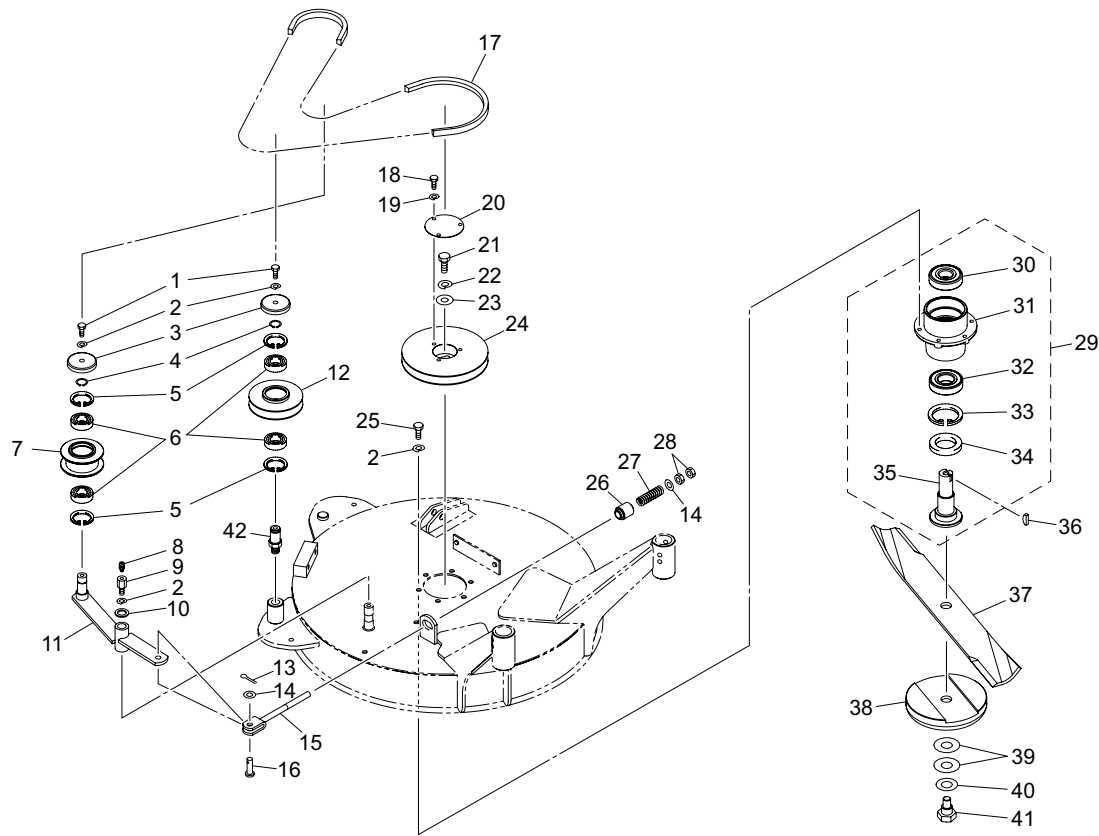

GM1700_A05_z01

Cat No.	Code No.	Part name	Qty	Remark	SN of application
A5-31	GM1700-2141Z2	HOUSING	1		
A5-32	K0612062060	BEARING, BALL SEAL 2RD 6206	1		
A5-33	K0402062001	RING, RETAINING R M62	1		
A5-34	K0824062080	OIL SEAL, MHSA40628	1		
A5-35	GM1500-0851Z0	SHAFT, ROTARY KNIFE	1		
A5-36	K0520707300	KEY, ROUND/SQUARE, M7-730	1		
A5a-37	K2530000120	BLADE, ROTARY 533L	1		
A5-38	GM1700-2150Z0	DISK, KNIFE GUARD	1		10001-10116
A5a-38					10117-
A5-39	K0211200001	SPRING, CONICAL DISC H M20	2		
A5-40	K5021020350	WASHER, NBS55 1-20-35	1		
A5-41	GM1700-2149Z1	BOLT, FIXING KNIFE	1		10001-10116
A5a-41	GM1500-0849A1	BOLT, FIXING KNIFE	1		10117-
A5-42	GM1700-2188Z8	PIN, TENSION RH-THREAD FOR LEFT COVER	1		

A6. Left Cutter Deck section B

GM1700

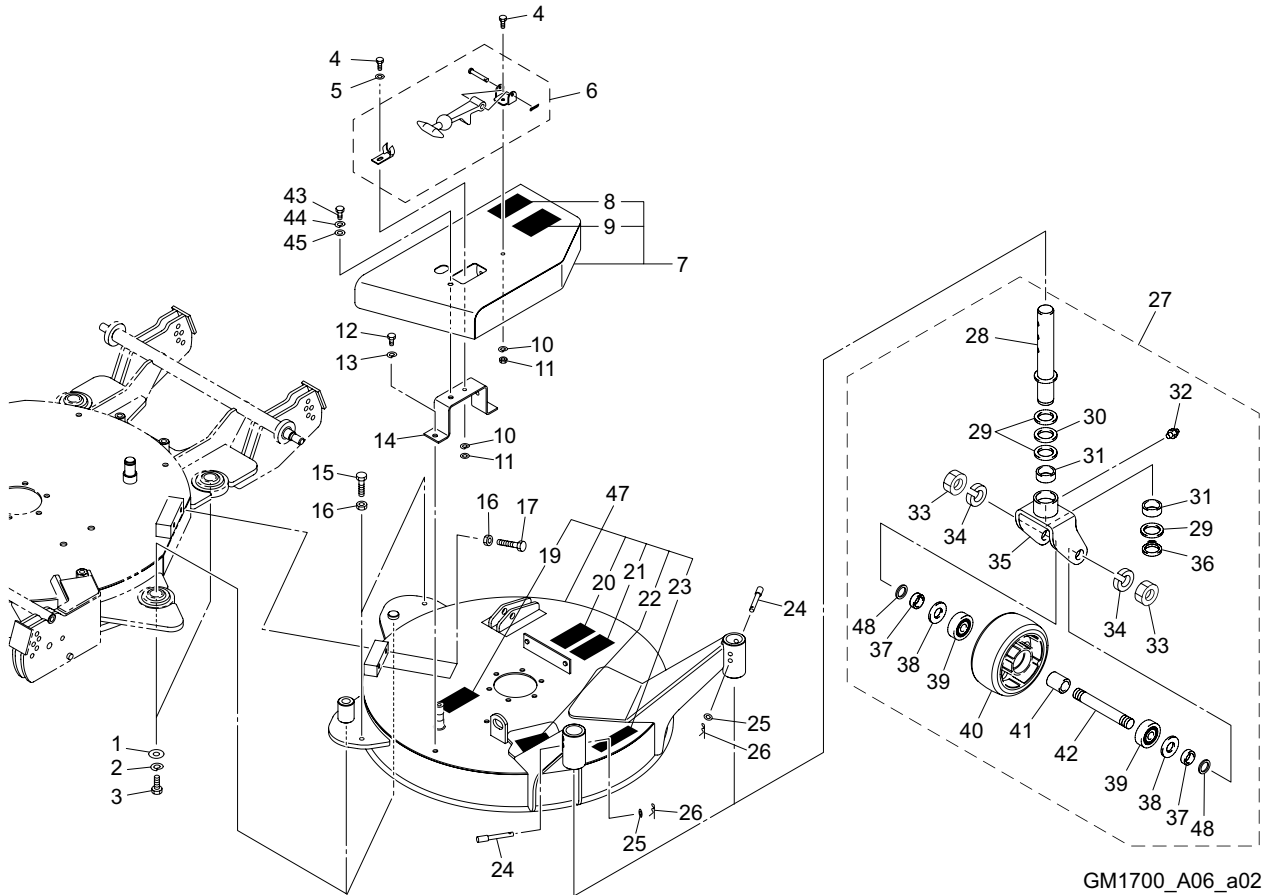

GM1700_A06_a02

Cat No.	Code No.	Part name	Qty	Remark	SN of application
A6-1	K5073210262	WASHER, SPHC 3.2-10-26	2		
A6-2	K0200100002	WASHER, SPRING M10	2		
A6-3	K0010100202	BOLT, HT M10-20	2		
A6-4	K0000060152	BOLT, M6-15	2		
A6-5	K5000060002	WASHER, M6	1		
A6-6	K1520000030	HOOK ASSY, RUBBER	1		
A6-7	GM1700-2154Z0	COVER COMP, BELT (LH)	1		
A6-8	K4205001530	DECAL, CAUTION TO ROTATING OBJECT	1		
A6-9	GM1700-2161Z0	DECAL, CUTTING HEIGHT OF CONTOUR DECK	1		
A6-10	K0200060002	WASHER, SPRING M6	2		
A6-11	K0100060002	NUT, M6	2		
A6-12	K0000080152	BOLT, M8-15	2		
A6-13	K0200080002	WASHER, SPRING M8	2		
A6-14	GM1700-2127Z2	RECEIVER, BELT COVER	1		
A6-15	K0071001152	BOLT, HT CHAMFERRED M10-30	2		
A6-16	K0100100002	NUT, M10	4		
A6-17	K0071001142	BOLT, HT CHAMFERRED M10-50	2		
A6-18					
A6-19	K4205001530	DECAL, CAUTION TO ROTATING OBJECT	1		
A6-20	K4205001650	DECAL, CAUTION TO FRYING OBJECT	1		
A6-21	K4205001780	DECAL, CAUTION CUTTING HANDS/FEET	1		
A6-22	K4205001600	DECAL, CAUTION TO MUTILATION	1		
A6-23	K4209001340	DECAL, CAUTION "DO NOT STEP"	1		
A6-24	K6031080512	PIN, FLAT HEAD HT M8-51	2		
A6-25	K5000080002	WASHER, M8	2		
A6-26	K0340800002	PIN, SNAP W/RETAINER M8	2		
A6-27	GM1500-0857A0	CASTER WHEEL ASSY, (FRONT)	2		20810-21327
A6a-27	GM1500-0857B0	CASTER WHEEL ASSY, (FRONT)	2		21328-
A6-28	GM1500-0870Z3	SHAFT	2		
A6-29	K5051030420	WASHER, C5191P 1-30-42	6		

A6. Left Cutter Deck section B

GM1700

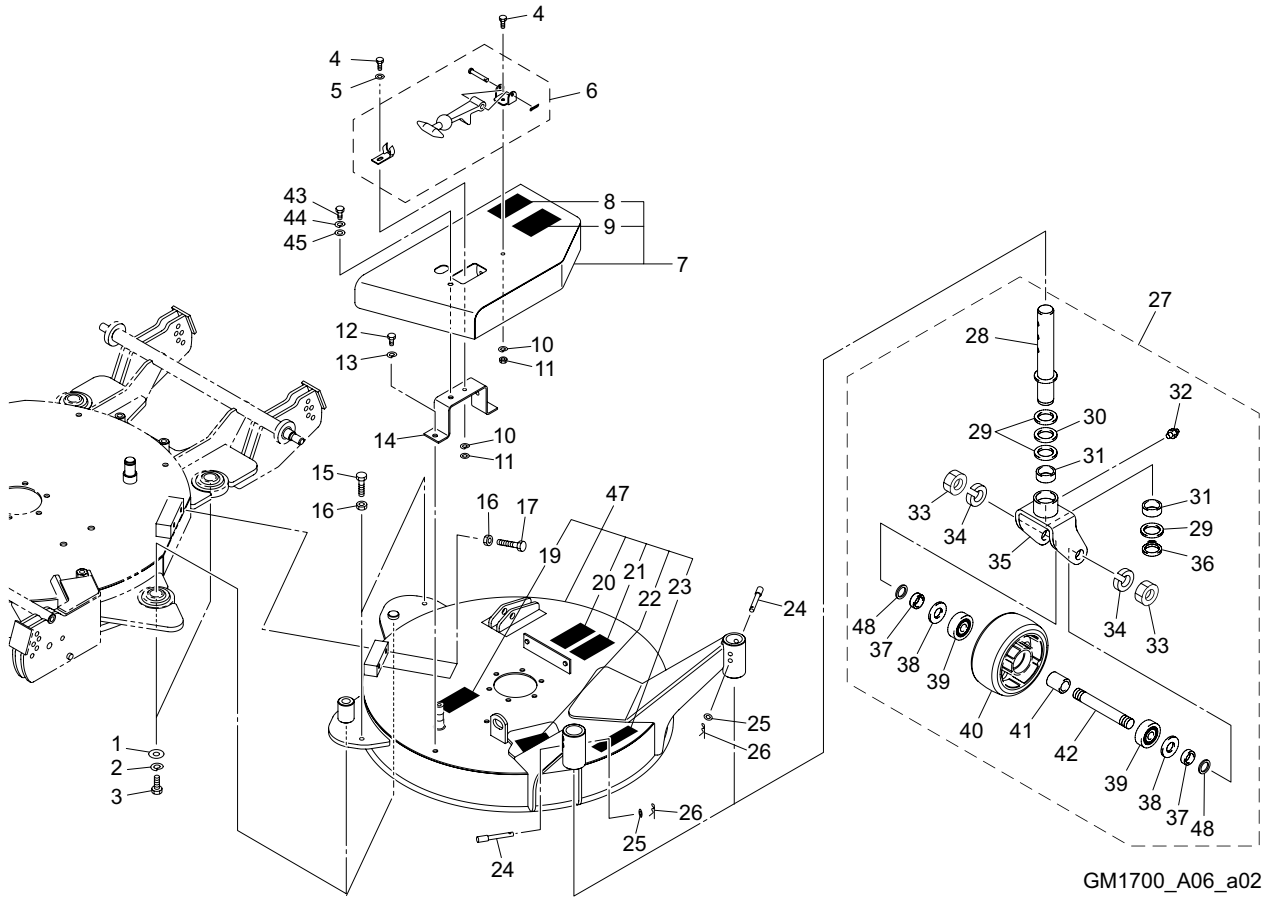

GM1700_A06_a02

Cat No.	Code No.	Part name	Qty	Remark	SN of application
A6-30	K5011030422	WASHER, SPCC 1-30-42	2		
A6-31	K6000000430	BUSH, 30-36-20	4		
A6-32	K1440000010	GREASE NIPPLE, STRAIGHT TYPE A	2		
A6-33	K0100200002	NUT, M20	4		
A6-34	K0200200002	WASHER, SPRING M20	4		
A6-35	GM1500-0871ZD	ARM, FRONT W/BUSH	2		
A6-36	K0401030001	RING, RETAINING S M30	2		
A6-37	K6212000222	COLLAR, STKM M20.2-28-9	4		
A6-38	K5030520430	WASHER, C2801P 0.5-20-43	4		
A6-39	K0612062040	BEARING, BALL SEAL 2RD 6204	4		
A6-40	K2110000030	WHEEL, RUBBER 150	2		20810-21327
A6a-40	K2110000060	WHEEL, RUBBER 150	2		21328-
A6-41	K6212000640	COLLAR, STKM M20.2-25.4-33	2		
A6-42	GM1500-0833A2	SHAFT, FRONT TIRE	2		
A6a-43	K0000080152	BOLT, M8-15	1		
A6a-44	K0200080002	WASHER, SPRING M8	1		
A6a-45	K5000080002	WASHER, M8	1		
A6a-46					
A6a-47	GM1700-2173Z0	COVER COMP, ROTARY (LH)	1		
A6-48	K5011020282	WASHER, SPCC 1-20-28	0-4	for adjustment	

A7. Right Cutter Deck section A

GM1700

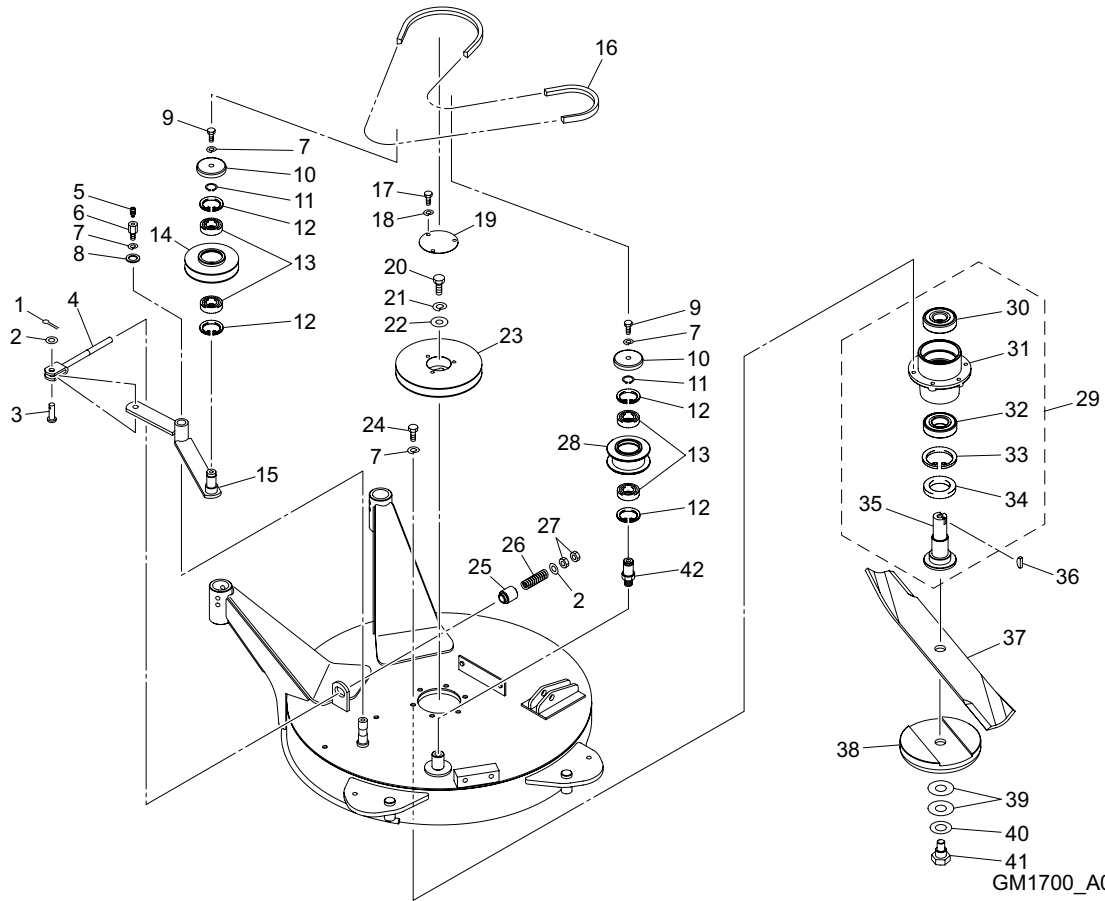

GM1700_A07_z01

Cat No.	Code No.	Part name	Qty	Remark	SN of application
A7-1	K0300025202	PIN, COTTER M2.5-20	1		
A7-2	K5000100002	WASHER, M10	2		
A7-3	K6031100258	PIN, FLAT HEAD HT M10-25	1		
A7-4	K7303000262	ROD, TENSION	1		
A7-5	K1440000010	GREASE NIPPLE, STRAIGHT TYPE A	1		
A7-6	GM1500-0827A2	BOLT, FIXING TENSION LEVER	1		
A7-7	K0200080002	WASHER, SPRING M8	9		
A7-8	K5012308242	WASHER, SPCC 2.3-8-24	1		
A7-9	K0000080152	BOLT, M8-15	2		
A7-10	GM1700-2113Z2	LID	2		
A7-11	K0401017001	RING, RETAINING S M17	2		
A7-12	K0402040001	RING, RETAINING R M40	4		
A7-13	K0612062030	BEARING, BALL SEAL 2RD 6203	4		
A7-14	GM1700-2125Z2	PULLEY, COUNTER	1		
A7-15	GM1700-2132A2	LEVER, TENSION (RH)	1		
A7-16	K2373100640	BELT, COGGED LOW EDGE H-PIV SA64	1		
A7-17	K0000060102	BOLT, M6-10	3		
A7-18	K0200060002	WASHER, SPRING M6	3		
A7-19	K517000012D	PLATE, SPCC BOLT COVER	1		
A7-20	K0010100252	BOLT, HT M10-25	1		
A7-21	K0200100002	WASHER, SPRING M10	1		
A7-22	K5074510422	WASHER, SPHC 4.5-10-42	1		
A7-23	GM1700-2123Z2	PULLEY, ROTARY	1		
A7-24	K0000080302	BOLT, M8-30	6		
A7-25	K6204000812	GUIDE, SPRING	1		
A7-26	K1000000048	SPRING, COMPRESSION M3.2-16.9-60	1		
A7-27	K0100100002	NUT, M10	2		
A7-28	GM1700-2124Z2	PULLEY, TENSION 2660	1		
A7-29	GM1700-2142Z0	HOUSING ASSY	1		
A7-30	K0612063050	BEARING, BALL SEAL 2RD 6305	1		

A7. Right Cutter Deck section A

GM1700

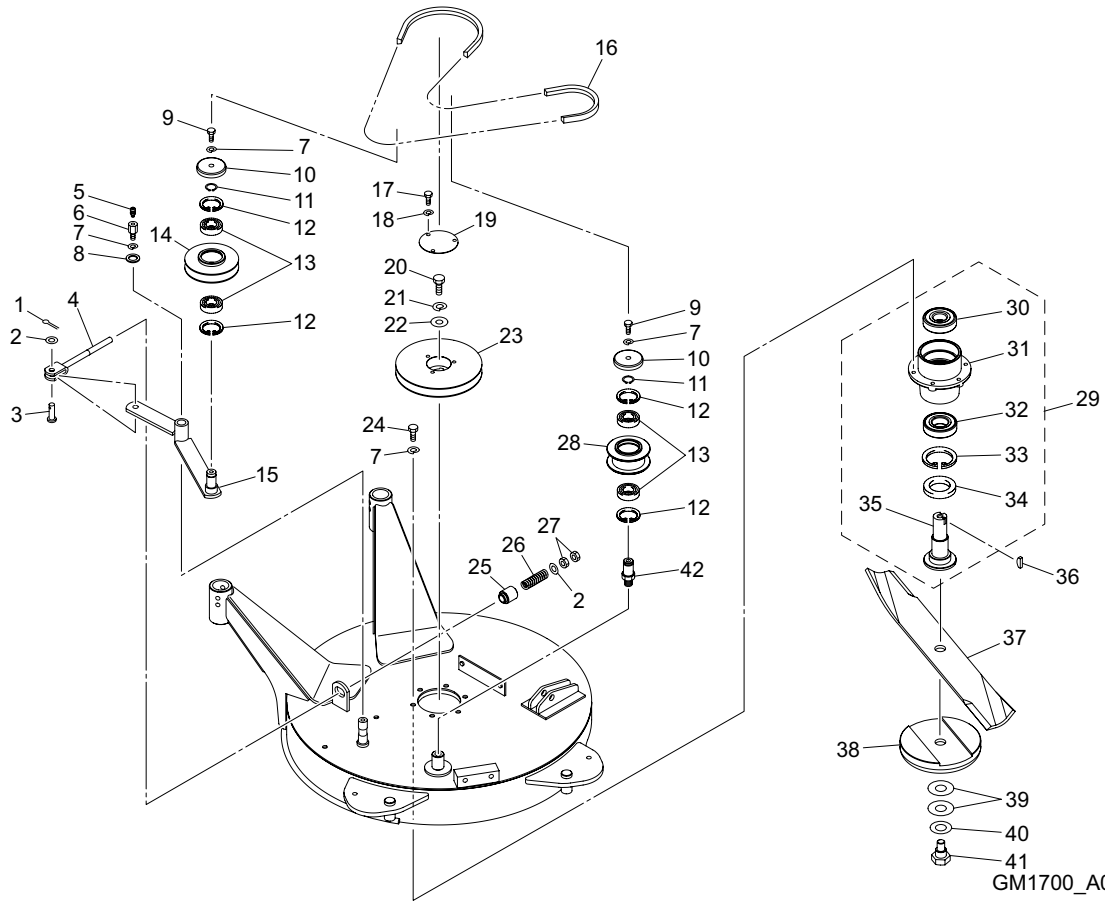

GM1700_A07_z01

Cat No.	Code No.	Part name	Qty	Remark	SN of application
A7-31	GM1700-2141Z2	HOUSING	1		
A7-32	K0612062060	BEARING, BALL SEAL 2RD 6206	1		
A7-33	K0402062001	RING, RETAINING R M62	1		
A7-34	K0824062080	OIL SEAL, MHSA40628	1		
A7-35	GM1500-0851Z0	SHAFT, ROTARY KNIFE	1		
A7-36	K0520707300	KEY, ROUND/SQUARE, M7-730	1		
A7a-37	K2530000120	BLADE, ROTARY 533L	1		
A7-38	GM1700-2150Z0	DISK, KNIFE GUARD	1		10001-10116
A7a-38					10117-
A7-39	K0211200001	SPRING, CONICAL DISC H M20	2		
A7-40	K5021020350	WASHER, NBS55 1-20-35	1		
A7-41	GM1700-2149Z1	BOLT, FIXING KNIFE	1		10001-10116
A7a-41	GM1500-0849A1	BOLT, FIXING KNIFE	1		10117-
A7-42	GM1700-2189Z8	PIN, TENSION LH-THREAD FOR RIGHT COVER	1		

A8. Right Cutter Deck section B

GM1700

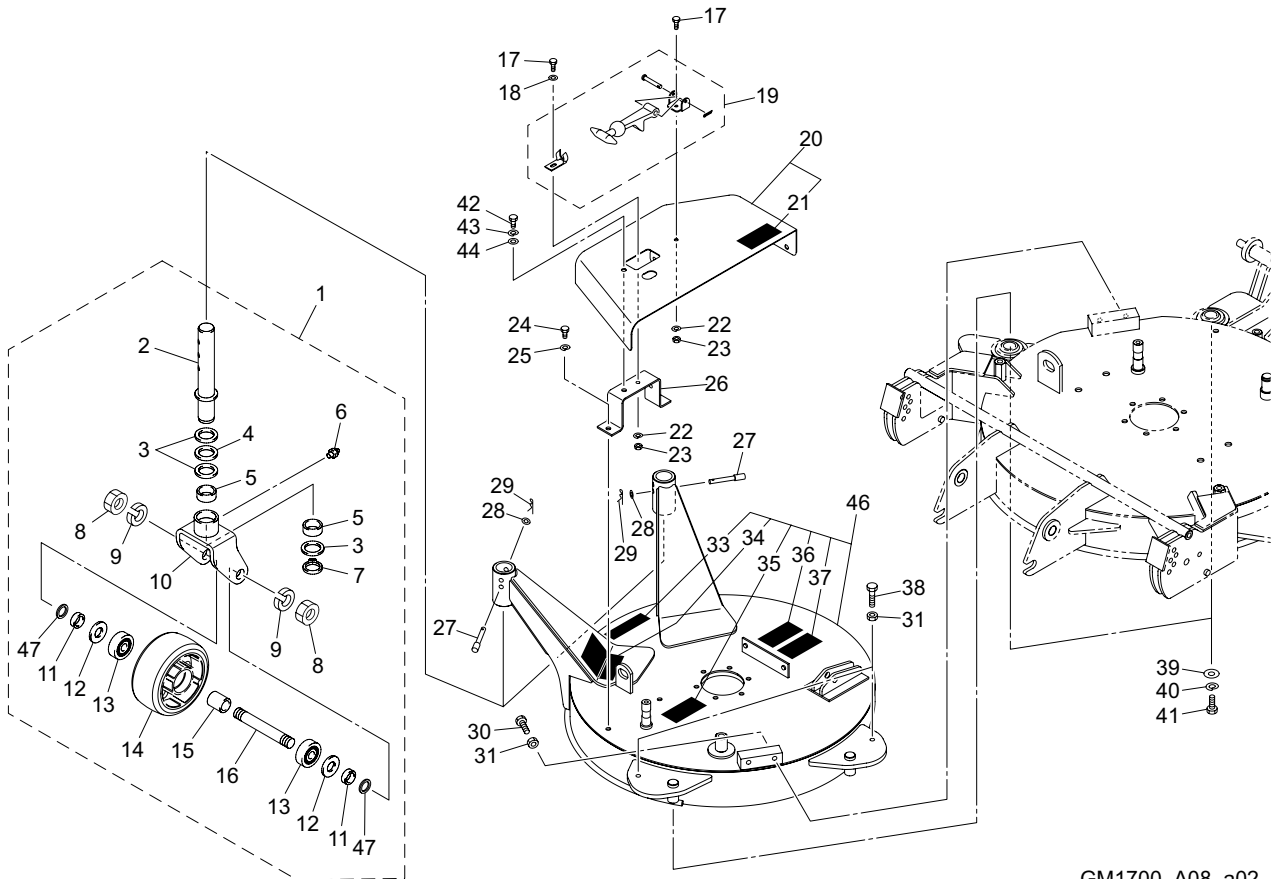

GM1700_A08_a02

Cat No.	Code No.	Part name	Qty	Remark	SN of application
A8-1	GM1500-0857A0	CASTER WHEEL ASSY, (FRONT)	2		20810-21327
A8a-1	GM1500-0857B0	CASTER WHEEL ASSY, (FRONT)	2		21328-
A8-2	GM1500-0870Z3	SHAFT	2		
A8-3	K5051030420	WASHER, C5191P 1-30-42	6		
A8-4	K5011030422	WASHER, SPCC 1-30-42	2		
A8-5	K6000000430	BUSH, 30-36-20	4		
A8-6	K1440000010	GREASE NIPPLE, STRAIGHT TYPE A	2		
A8-7	K0401030001	RING, RETAINING S M30	2		
A8-8	K0100200002	NUT, M20	4		
A8-9	K0200200002	WASHER, SPRING M20	4		
A8-10	GM1500-0871ZD	ARM, FRONT W/BUSH	2		
A8-11	K6212000222	COLLAR, STKM M20.2-28-9	4		
A8-12	K5030520430	WASHER, C2801P 0.5-20-43	4		
A8-13	K0612062040	BEARING, BALL SEAL 2RD 6204	4		
A8-14	K2110000030	WHEEL, RUBBER 150	2		20810-21327
A8a-14	K2110000060	WHEEL, RUBBER 150	2		21328-
A8-15	K6212000640	COLLAR, STKM M20.2-25.4-33	2		
A8-16	GM1500-0833A2	SHAFT, FRONT TIRE	2		
A8-17	K0000060152	BOLT, M6-15	2		
A8-18	K5000060002	WASHER, M6	1		
A8-19	K1520000030	HOOK ASSY, RUBBER	1		
A8-20	GM1700-2155Z0	COVER COMP, BELT (RH)	1		
A8-21	K4205001530	DECAL, CAUTION ROTATING OBJECT	1		
A8-22	K0200060002	WASHER, SPRING M6	2		
A8-23	K0100060002	NUT, M6	2		
A8-24	K0000080152	BOLT, M8-15	2		
A8-25	K0200080002	WASHER, SPRING M8	2		
A8-26	GM1700-2127Z2	RECEIVER, BELT COVER	1		
A8-27	K6031080512	PIN, FLAT HEAD HT M8-51	2		
A8-28	K5000080002	WASHER, M8	2		

A8. Right Cutter Deck section B

GM1700

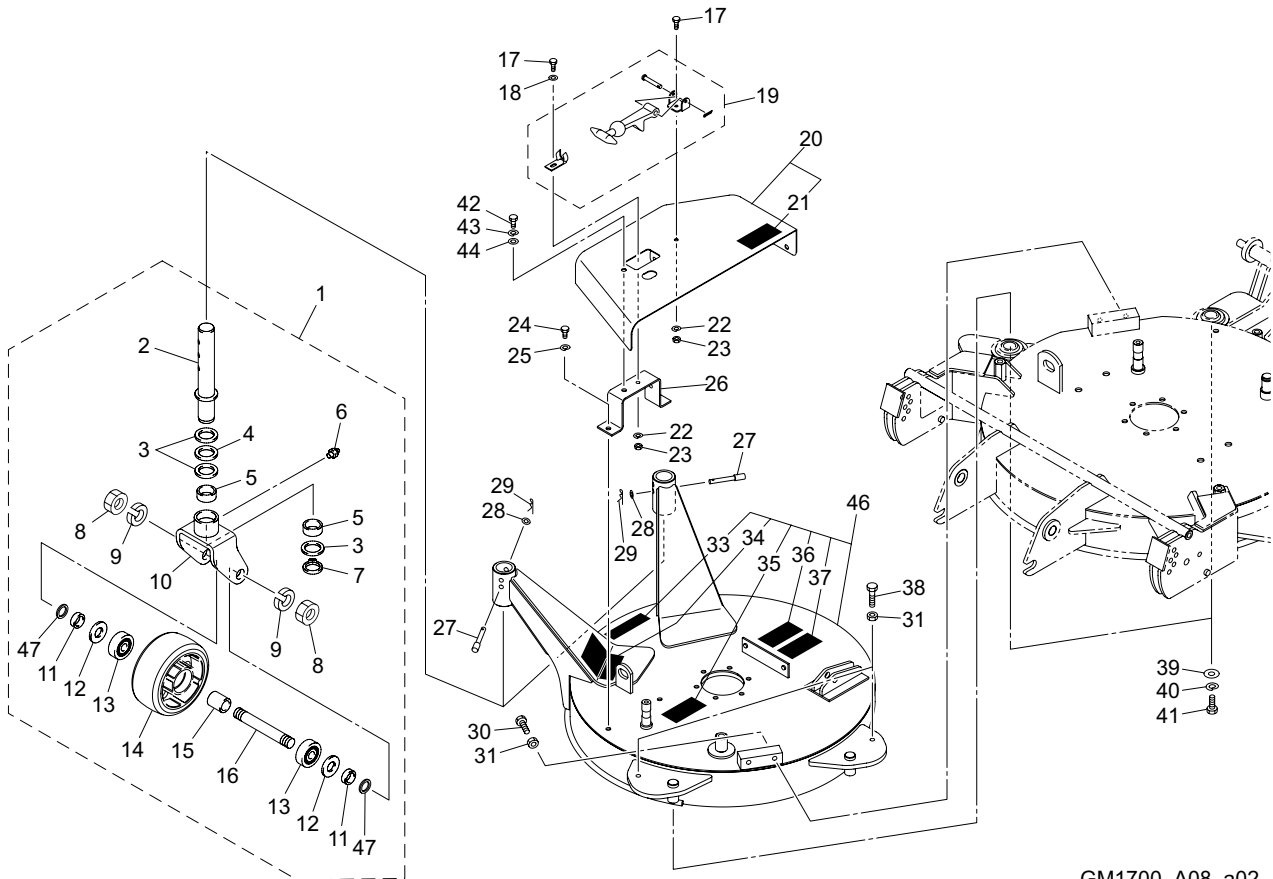

GM1700_A08_a02

Cat No.	Code No.	Part name	Qty	Remark	SN of application
A8-29	K0340800002	PIN, SNAP W/RETAINER M8	2		
A8-30	K0071001142	BOLT, HT CHAMFERRED M10-50	2		
A8-31	K0100100002	NUT, M10	4		
A8-32					
A8-33	K4209001340	DECAL, CAUTION "DO NOT STEP"	1		
A8-34	K4205001780	DECAL, CAUTION CUTTING HANDS/FEET	1		
A8-35	K4205001530	DECAL, CAUTION ROTATING OBJECT	1		
A8-36	K4205001600	DECAL, CAUTION CUTTING HANDS/FEET	1		
A8-37	K4205001650	DECAL, CAUTION FRYING OBJECT	1		
A8-38	K0071001152	BOLT, HT CHAMFERRED M10-30	2		
A8-39	K5073210262	WASHER, SPHC 3.2-10-26	2		
A8-40	K0200100002	WASHER, SPRING M10	2		
A8-41	K0010100202	BOLT, HT M10-20	2		
A8a-42	K0000080152	BOLT, M8-15	1		
A8a-43	K0200080002	WASHER, SPRING M8	1		
A8a-44	K5000080002	WASHER, M8	1		
A8a-45					
A8a-46	GM1700-2175Z0	COVER COMP, ROTARY (RH)	1		
A8-47	K5011020282	WASHER, SPCC 1-20-28	0-4	for adjustment	

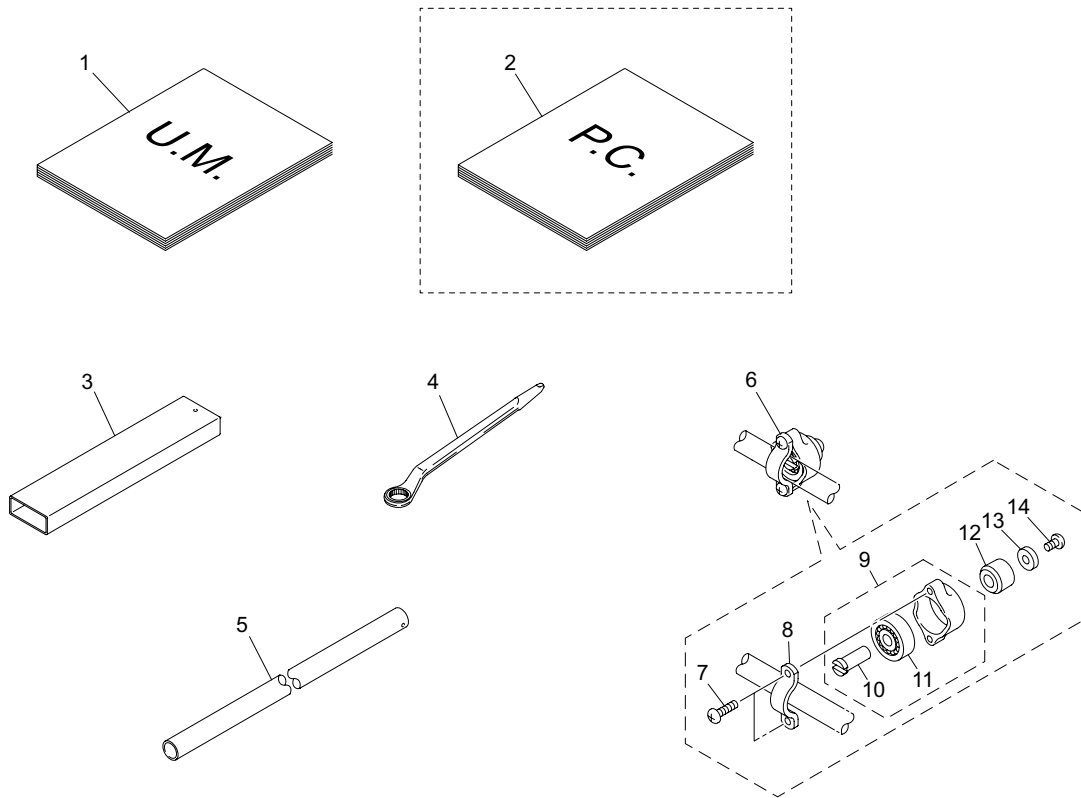

GM1700_A09_z03

Cat No.	Code No.	Part name	Qty	Remark	SN of application
A9b-1	GM1700--UMA-GBZ	O-MANUAL, GM1700-CON GB-EN	1	Available for sale	
A9b-2	GM1700--PCA-GBZ	P-CATALOG, GM1700-CON GB-EN	1		
A9-3	GM1500-1205ZD	PIPE, SQUARE	1		
A9-4	GM1500-1206Z0	SPANNER, RING	1		
A9-5	GM1500-1207ZD	PIPE, FOR RING SPANNER	1		
A9-6	K4802000140	TEST APPLIANCE, BLADE BALANCING	1		
A9-7	K0048050302	SCREW, + ROUND HEAD W/SW M5-30	2		
A9-8	K5211000012	PLATE, SS41F BALANCING BLADE	1		
A9-9	K5920000010	BALANCER, PLASTIC FOR BLADE	1		
A9-10	K6130000010	SHAFT, BEARING	1		
A9-11	K0600062000	BEARING, BALL 6200	1		
A9-12	K6204000272	BOSS, FOR KNIFE	1		
A9-13	K5011605142	WASHER, SPCC 1.6-5-14	1		
A9-14	K0048050102	SCREW, + ROUND HEAD W/SW M5-10	1		

MEMO

BARONESS[®]
Quality on Demand

 **KYOEISHA CO., LTD.**
Head Office 1-26, Miyuki-cho, Toyokawa-city, Tel :+81-533-84-1390
Aichi-pref, 442-8530 JAPAN Fax :+81-533-84-1220