

GM1700

Contour Deck for GM1700

Owner's Operating Manual

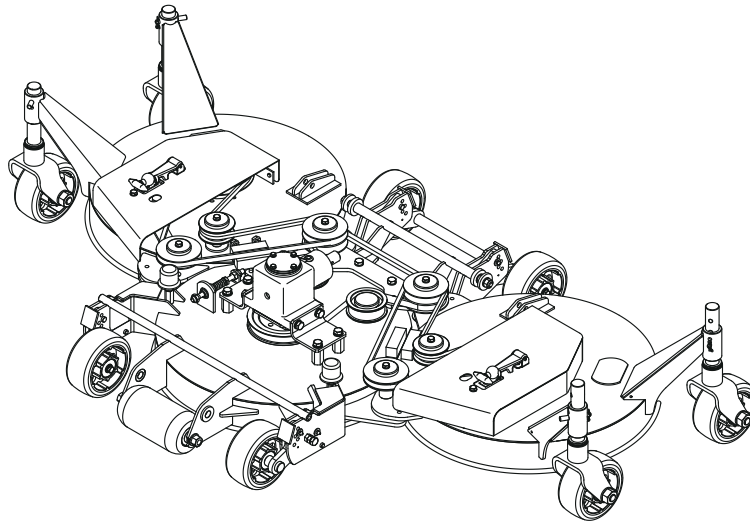

Serial No. GM1700 : 21241- (GM1700 Main Vehicle)

"Required reading"
Read this manual before using the machine.

BARONESS[®]
Quality on Demand

Original Instructions Ver.2.0

Greeting

Thank you for purchasing the Baroness product. This manual describes the proper handling, adjustment, and inspection of your product. We hope you will use the product safely, and take advantage of its best performance. For details on the handling, adjustment and inspection of the main vehicle, refer to the Owner's Operating Manual for the main vehicle.

QR Code

A QR code label is affixed on a main vehicle for the mower deck. Scan the QR code with your smartphone for easy access to Baroness Manual Reference Service where you can browse Owner's Operating Manual and Parts Catalog. For details, refer to the Owner's Operating Manual of the main vehicle.

Read this manual carefully to ensure that you thoroughly understand how to properly operate and maintain the product, and to avoid causing injury to yourself or others.

The operator is responsible for operating the product properly and safely.

Maintenance service for this machine should be performed by a mechanic with expertise.

If you have any questions concerning maintenance or genuine parts, please contact a Baroness dealer or Kyoeshia.





When making inquiries about your product, please specify the model and serial number.

When loaning or transferring the product, please also provide this manual together with the product.

Kyoeisha Co., Ltd.

Warning Symbols

This manual uses the following warning symbols for handling precautions that are important for your safety.

 <small>696cq5-001</small>	Warning symbol
<p>This symbol indicates the articles regarding “Danger,” “Warning,” or “Caution.” Those articles describe important safety precautions and so read them carefully to understand completely before operating the machine.</p> <p>Failure to adequately follow these safety precautions may cause an accident.</p>	
<p> Danger</p> <p>This symbol indicates that serious injury or death will occur if the warning is ignored.</p>	
<p> Warning</p> <p>This symbol indicates that serious injury or death may occur if the warning is ignored.</p>	
<p> Caution</p> <p>This symbol indicates that injury or damage to property may occur if the warning is ignored.</p>	
<p>Important</p> <p>This symbol indicates precautions on the mechanism of the machine.</p>	

Introduction

Precautionary Statement

 Caution

The information described in this manual is subject to change for improvement without prior notice.

When replacing parts, be sure to use genuine Baroness parts or parts designated by Kyoisha.

Note that the Baroness product warranty may not apply to defects caused by the use of parts from other companies.

Prior to use, carefully read the following manuals to thoroughly understand the contents for safe and correct operation.

- Baroness Owner's Operating Manual

Purpose

This mower deck is intended for cutting turf grass at golf courses.

Do not use this machine in any way other than its intended purpose, and do not modify the machine.

Operating this mower deck for other purposes and modifying it may be very dangerous and may cause damage to the machine.

Safety	Page 1-1
Safe Operating Practices	Page 1-2
Disposal	Page 2-1
Recycle and Waste Disposal	Page 2-2
Product Overview	Page 3-1
Specifications	Page 3-2
Names of Each Section	Page 3-3
Regulation Decals	Page 3-4
Safety Signs and Instruction Signs	Page 3-4
Handling Instructions	Page 4-1
Handling Precautions	Page 4-2
Pre-installation Adjustments	Page 4-2
Inspection and Cleaning	Page 4-5
Storage	Page 4-7
Maintenance	Page 5-1
Precautions for Maintenance	Page 5-2
Greasing	Page 5-2
Adjustment and Replacement	Page 5-4
Storage	Page 5-12
Appended Table	Page 6-1
Tightening Torques	Page 6-2
Maintenance Schedule	Page 6-5
List of Adjusted Values	Page 6-5
Records	Page 7-1
Maintenance Records	Page 7-2

GM1700

Contents

Safe Operating Practices Page 1-2

Safety

Failure to adequately follow these safety precautions may cause an accident resulting in injury or death.

⚠ Danger

This product is designed to ensure safe operation and has been tested and inspected thoroughly before shipment from the factory. The product is equipped with safety devices to prevent accidents.

However, whether the product demonstrates its original performance level depends on the manner in which it is operated and handled, as well as the manner in which it is managed on a daily basis.

Inappropriate use or management of the product may result in injury or death.

Observe the following safety instructions to ensure safe operation.

Safe Operating Practices

Read Safe Operating Practices described in the Owner's Operating Manual of Baroness main vehicle equipped with this mower deck thoroughly.

Recycle and Waste Disposal Page 2-2

About RecyclePage 2-2

About Waste Disposal Page 2-2

Disposal

Disposal

Recycle and Waste Disposal

About Recycle

Recycling battery etc. is recommended for environmental conservation and economical use of resources.

It may be required by local laws.

About Waste Disposal

Make sure that waste generated when servicing or repairing the machine is disposed of in accordance with local regulations. (e.g. waste oil, antifreeze, rubber products, and wires etc.)

- Specifications Page 3-2**
 - SpecificationsPage 3-2
 - Features of Contour Deck Page 3-3
- Names of Each Section Page 3-3**
- Regulation DecalsPage 3-4**
 - Positions of Regulation Decals Page 3-4
 - Description of Regulation Decals Page 3-4
- Safety Signs and Instruction Signs Page 3-4**
 - About Safety Decals and Instruction
DecalsPage 3-4
 - Positions of Safety Decals and
Instruction Decals Page 3-4
 - Description of Safety Decals and
Instruction Decals Page 3-4

Product Overview

Specifications

Specifications

Model		Contour Deck for GM1700	
Name		Contour Deck for GM1700	
Dimensions	Total length	108 cm [255 cm]	42.52 in [100.39 in]
	Total width	183 cm [183 cm]	72.05 in [72.05 in]
	Total height	37 cm	14.57 in
Weight		166 kg [896 kg]	365.96 lb [1,975.31 lb]
Gear box grease capacity		260 g	9.17 oz
Operating width (Mowing width)		151 cm	59.45 in
Operating height (Mowing height)		35 - 95 mm (15 mm spacing, 5 levels)	1.38 - 3.74 in (0.59 in spacing, 5 levels)
Number of Blades		3	
Blade length		533 mm	20.98 in
Efficiency		6,040 m ² /h (5.0 km/h x mowing width x 0.8)	1.5 acres/hour (3.11 mph x mowing width x 0.8)

* Values within [] are dimensions and weight of GM1700 main vehicle equipped with Contour Deck, ROPS and empty fuel tank.

Features of Contour Deck

1. The swing of the left and right mower decks enables you to cut grass on undulations. The left and right mower decks each swing 8° up and down [up and down movement of left/right blade tips is ±76 mm (±3.0 in)].

Level

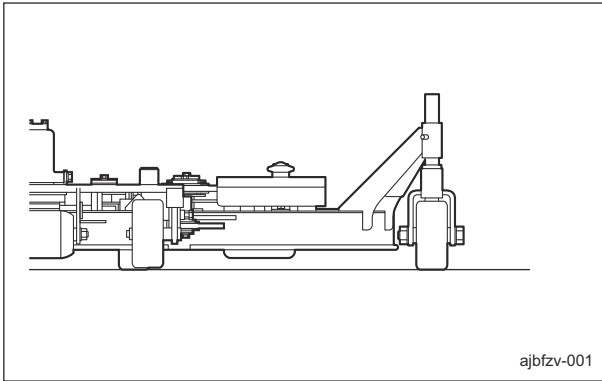

ajbfzv-001

Features of Contour Deck_001

Up

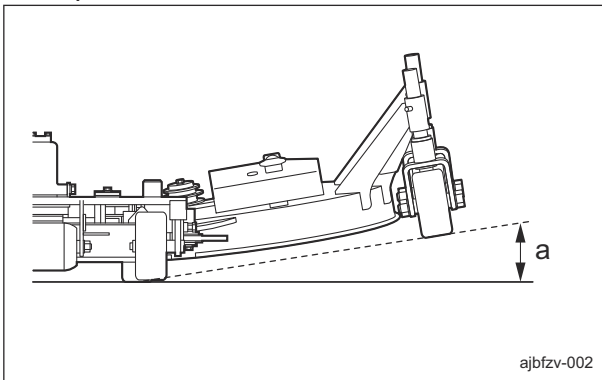

ajbfzv-002

Features of Contour Deck_002

a	8°
---	----

Down

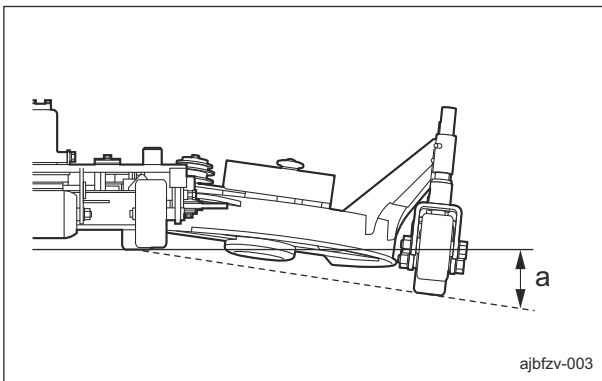

ajbfzv-003

Features of Contour Deck_003

a	8°
---	----

2. Grass clippings are discharged toward the back.

Names of Each Section

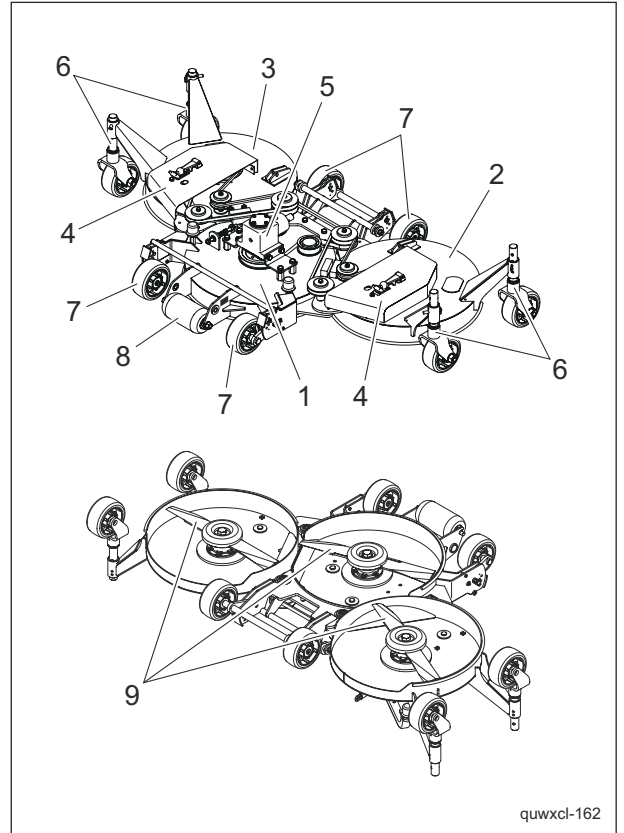

quwxcl-162

Names of Each Section_001

1	Center mower deck
2	Left mower deck
3	Right mower deck
4	Belt cover
5	Gearbox
6	Caster
7	Cutting height gauge wheel
8	Front roller
9	Rotary knife

Product Overview

Regulation Decals

Positions of Regulation Decals

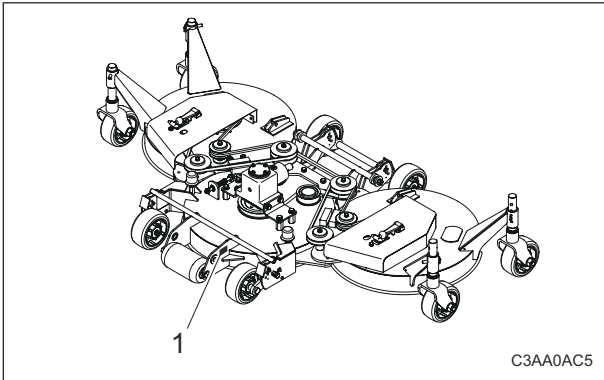

Positions of Regulation Decals_001

1	Serial number plate
---	---------------------

Description of Regulation Decals

Serial Number Plate

The serial number plate indicates the serial number.

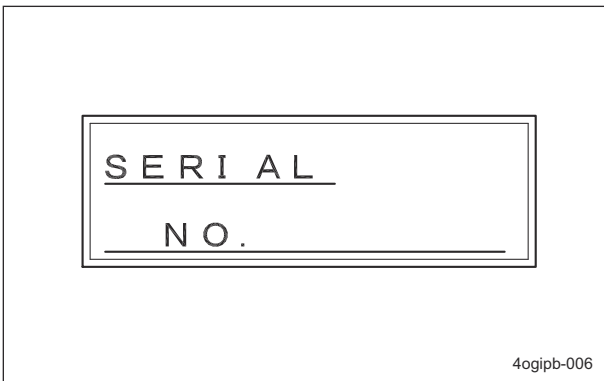

Serial Number Plate_001

Safety Signs and Instruction Signs

About Safety Decals and Instruction Decals

Important

Safety decals and instruction decals are attached to this mower deck. Make sure that decals are preserved in their entirety. If they are damaged, become dirty, or peel off, replace them with new ones.

Part numbers for decals that need to be replaced are listed in the parts catalog. Order them from a Baroness dealer or Kyoeshia.

Positions of Safety Decals and Instruction Decals

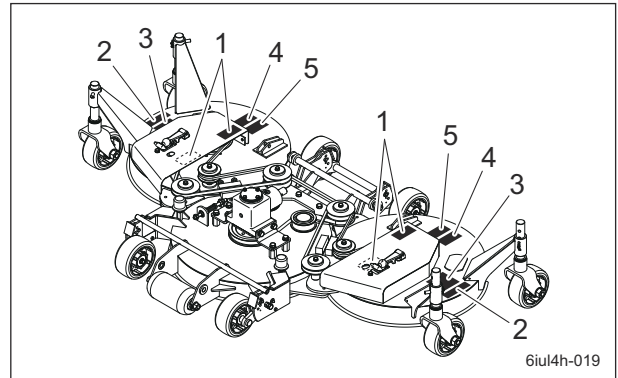

Positions of Safety Decals and Instruction Decals_001

1	Caution to rotating object decal
2	DO NOT STEP caution decal
3	Caution to mutilation decal
4	Caution for hand or leg injury decal
5	Caution to flying object decal

Description of Safety Decals and Instruction Decals

Caution to Rotating Object Decal

K4205001530

Decal, caution to rotating object

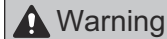

Watch for rotating parts - Keep your hands away from the belts while the engine is running.

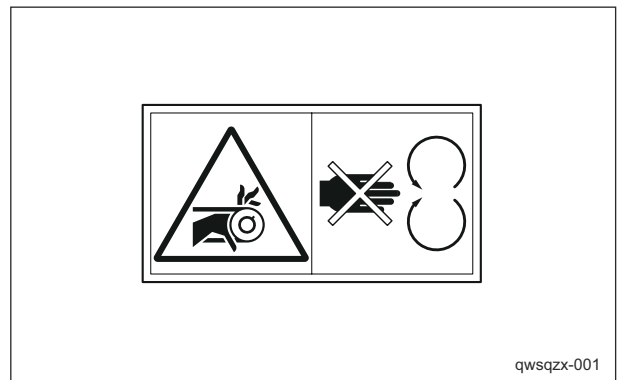

Caution to Rotating Object Decal_001

Product Overview

DO NOT STEP Caution Decal

K4209001340
Decal, caution "DO NOT STEP"

 **Caution**
Do not step.

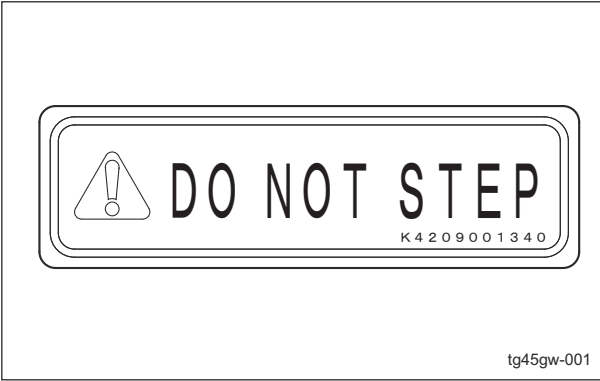

DO NOT STEP Caution Decal_001

Caution for Hand or Leg Injury Decal

K4205001780
Decal, caution for hand or leg injury

 **Warning**
May cut your hand or leg - When the blades are rotating, keep away from the machine.

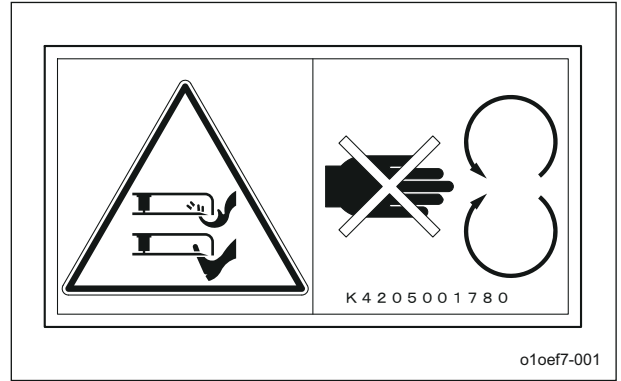

Caution for Hand or Leg Injury Decal_001

Caution to Mutilation Decal

K4205001600
DECAL, CAUTION TO MUTILATION

 **Warning**
May cut your hand or leg - Stop the cutter rotation and engine. Otherwise you may get injured.

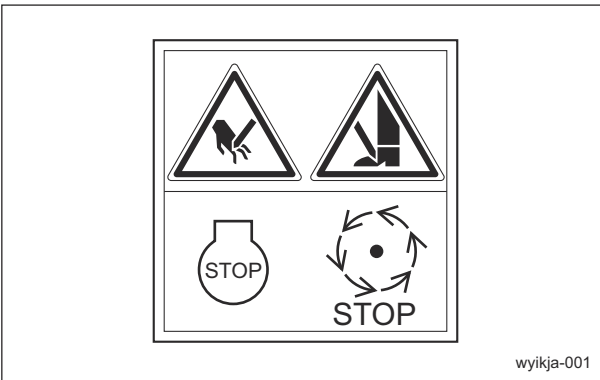

Caution to Mutilation Decal_001

Caution to Thrown Object Decal

K4205001650
DECAL, SCATTERING OBJECT

 **Caution**
Thrown objects - Be sure that people around the machine keep a safe distance away.

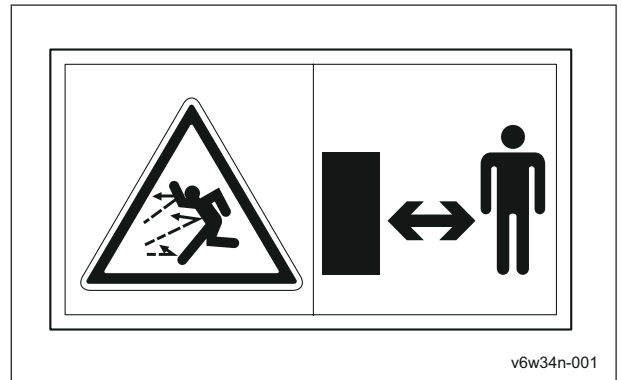

Caution to Thrown Object Decal_001

Product Overview

Handling Instructions

- Handling Precautions Page 4-2**
- Pre-installation Adjustments Page 4-2**
 - Installation of Contour Deck Page 4-2
 - Installation of Universal Joint Page 4-5
- Inspection and Cleaning Page 4-5**
 - Rotary Knife Page 4-5
 - Cover Page 4-6
 - Belt Page 4-6
 - Roller Page 4-6
 - Caster Page 4-6
 - Bolts and Nuts Page 4-7
 - Mower Deck Page 4-7
- Storage Page 4-7**
 - Short-Term Storage Page 4-7

Handling Instructions

Handling Precautions

Important

This manual contains descriptions for handling the mower deck. For details on handling, refer to this manual and the main vehicle GM1700 Owner's Operating Manual.

Pre-installation Adjustments

Installation of Contour Deck

1. Move the main vehicle and mower deck onto a level surface.
2. If any unnecessary attachments are mounted on the main vehicle, remove them.
Note:
 Tie the universal joint to the main vehicle with string, etc., in order to prevent it from falling.
3. Install the front rods onto the mower deck with the pin and clip pin.

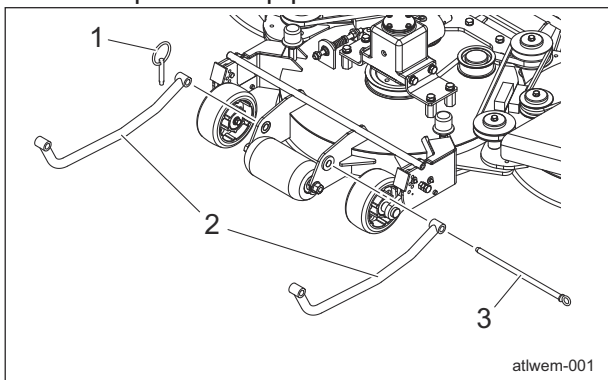

Installation of Contour Deck_001

1	Clip pin
2	Front rod
3	Pin

4. Install the deck tow plates onto the mower deck with the nuts. Follow the same installation step for the left and right sides.

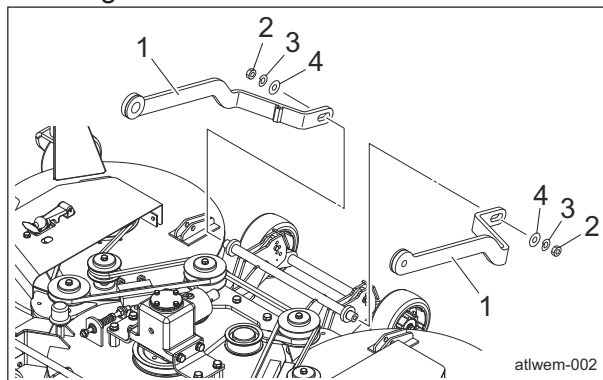

Installation of Contour Deck_002

1	Deck tow plate
2	Nut
3	Spring washer
4	Washer

5. Install the rubber stopper onto the right deck tow plate.

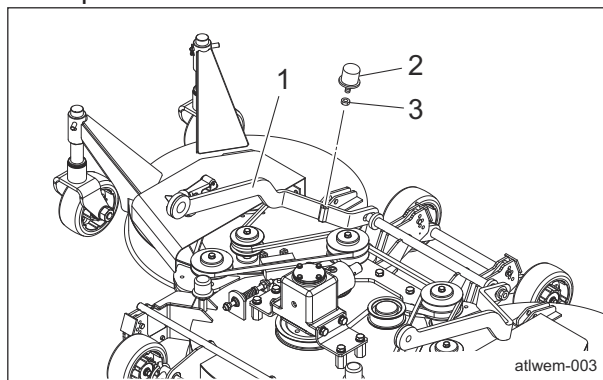

Installation of Contour Deck_003

1	Deck tow plate
2	Rubber stopper
3	Nut

Handling Instructions

6. Install the lift chain, and then secure it with the cotter pin.
Follow the same installation step for the left and right sides.

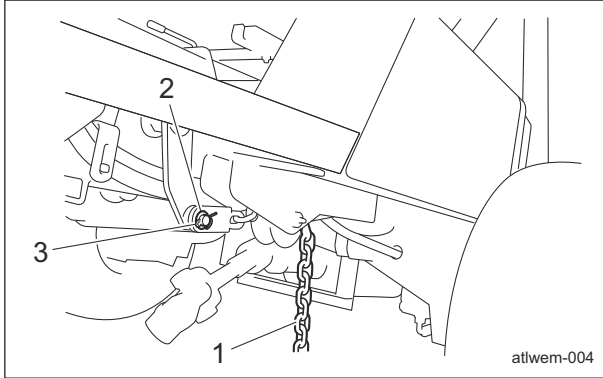

Installation of Contour Deck_004

1	Lift chain
2	Washer
3	Cotter pin

7. Install the rubber stopper onto the stopper arm.
Follow the same installation step for the left and right sides.

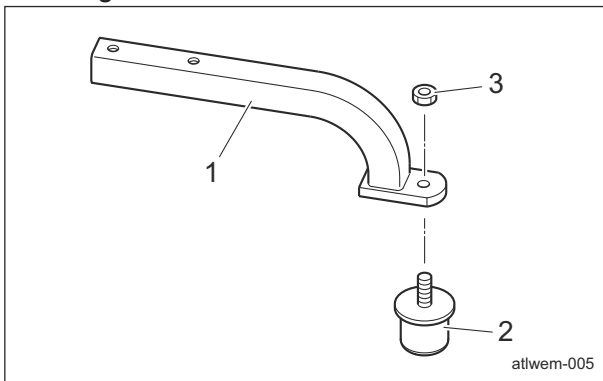

Installation of Contour Deck_005

1	Stopper arm
2	Rubber stopper
3	Nut

8. Install the stopper arm onto the main vehicle with the bolt and nut.
Follow the same installation step for the left and right sides.

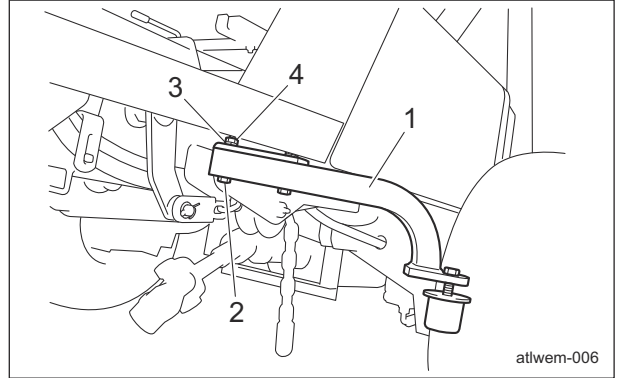

Installation of Contour Deck_006

1	Stopper arm
2	Bolt
3	Spring washer
4	Nut

9. Install the link fulcrum shaft onto the main vehicle with the bolt and nut.
Follow the same installation step for the left and right sides.

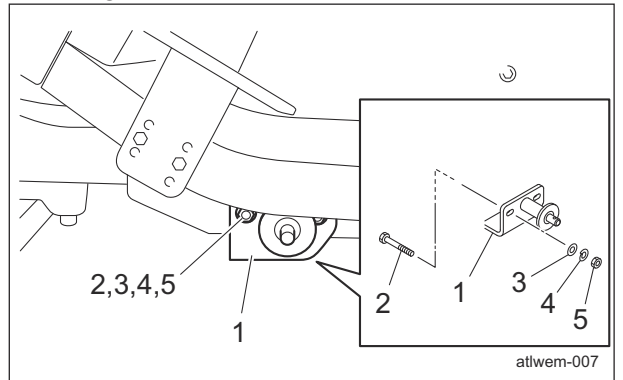

Installation of Contour Deck_007

1	Link fulcrum shaft
2	Bolt
3	Washer
4	Spring washer
5	Nut

10. Raise the bumper with a hoist, etc., to lift up the front wheels of the main vehicle.

Handling Instructions

11. Place the mower deck in the appropriate position.

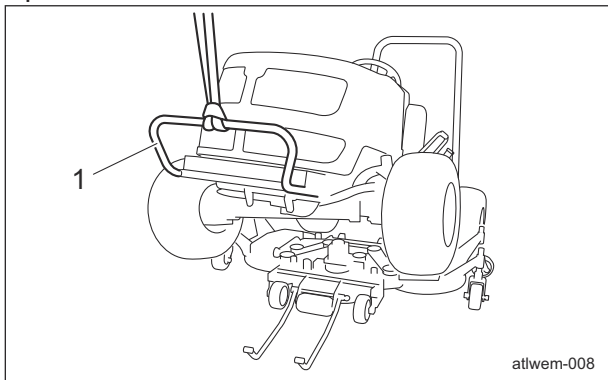

Installation of Contour Deck_008

1	Bumper
---	--------

12. Install the universal joint onto the gearbox.
"Installation of Universal Joint" (Page 4-5)

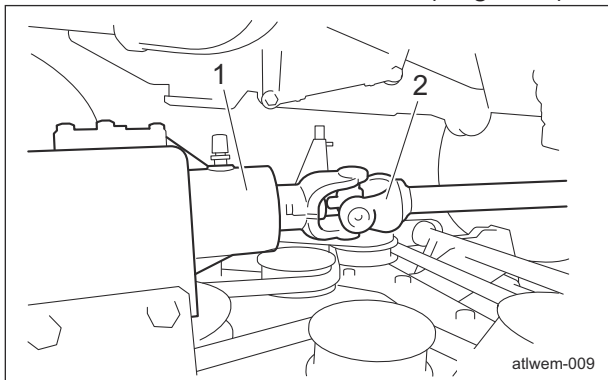

Installation of Contour Deck_009

1	Gearbox
2	Universal joint

13. Lower the main vehicle until it is level.
14. Install the front rods onto the main vehicle with the pin and clip pin.

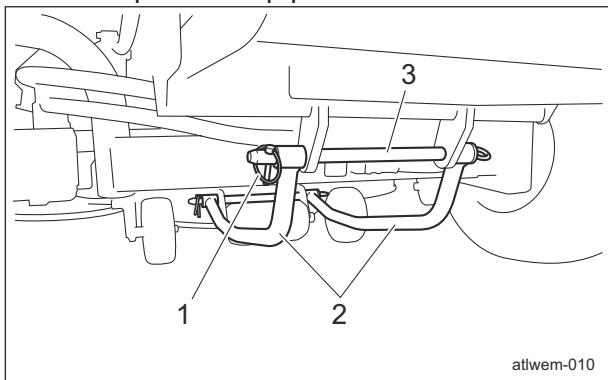

Installation of Contour Deck_010

1	Clip pin
2	Front rod
3	Pin

Important

Make sure that the lift chain is not twisted.

15. Install the lift chain onto the mower deck with the pin, and then secure it with the cotter pin. Follow the same installation step for the left and right sides.

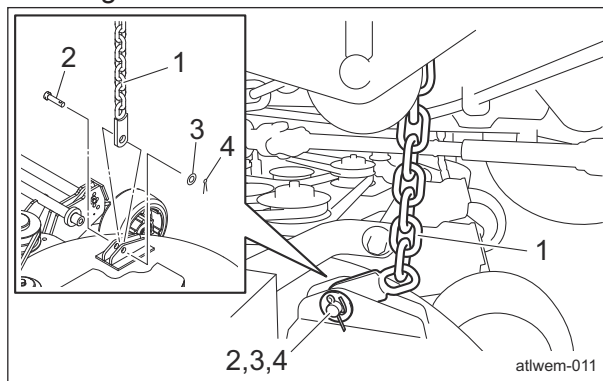

Installation of Contour Deck_011

1	Lift chain
2	Pin
3	Washer
4	Cotter pin

16. Install the deck tow plate onto the main vehicle with the cotter pin. Follow the same installation step for the left and right sides.

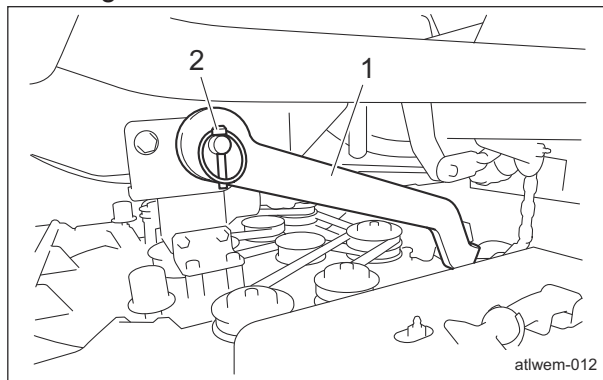

Installation of Contour Deck_012

1	Deck tow plate
2	Clip pin

17. Start the engine, and then raise the mower deck to the highest position.

18. Make sure that the heights of the left and right mower decks are the same.

Handling Instructions

Caution

Be sure to stop the engine before making adjustments.

Note:

If the decks are not equally raised, adjust the installation position of the link fulcrum shafts.

- 19. Make sure that the swing stoppers make contact equally on the left and right sides. "Swing Stoppers" (Page 5-11)
- 20. Adjust lift stopper contact. "Lift Stoppers" (Page 5-12)

Note:

For removing the contour deck, reverse the installation procedure.

Installation of Universal Joint

Important

Check the alignment point of the splines before installing (inserting) the universal joint.

- 1. Check the alignment point of the splines for connecting the universal joint.

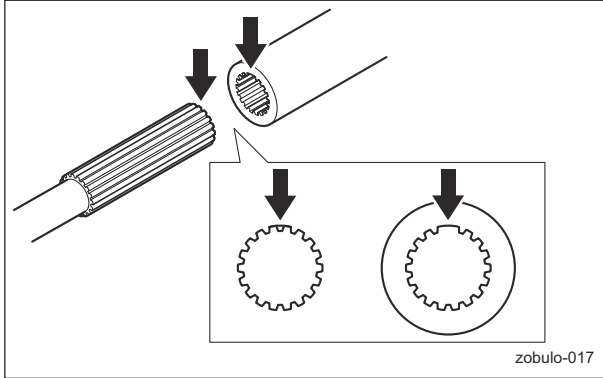

Installation of Universal Joint_001

- 2. Align the holes of the universal joint and gearbox, and then install it with the pin, washer and cotter pin.

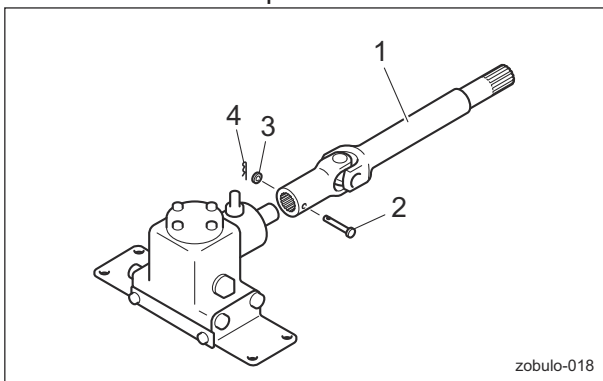

Installation of Universal Joint_002

1	Universal joint
2	Pin
3	Washer
4	Cotter pin

Note:

For removing the universal joint, reverse the installation procedure.

Inspection and Cleaning

Inspect and clean the machine with the goals of the followings.

- Accident prevention
- Failure prevention
- Performance retention

Make efforts for early detection of the machine failure and prevention of the sudden occurrence of trouble.

Perform maintenance and repair works immediately if any abnormality is found in the machine.

Rotary Knife

Inspection of Rotary Knife

Caution

When touching edged tools, wear gloves since they could cut your hands.

Important

Frequently inspect the rotary knife since it may become dull quickly if the machine is operated in an environment of dry soil or sand.

- 1. Make sure that the rotary knife is not bent.
- 2. Make sure that the rotary knife is not chipped.
- 3. Check to see how much the rotary knife is worn.
- 4. Make sure that the rotary knife is not worn asymmetrically.
- 5. Make sure that the mounting bolt for the rotary knife is not loose.

Handling Instructions

6. Make sure that there are no cracks or tears between the sail and flat part of the rotary knife.

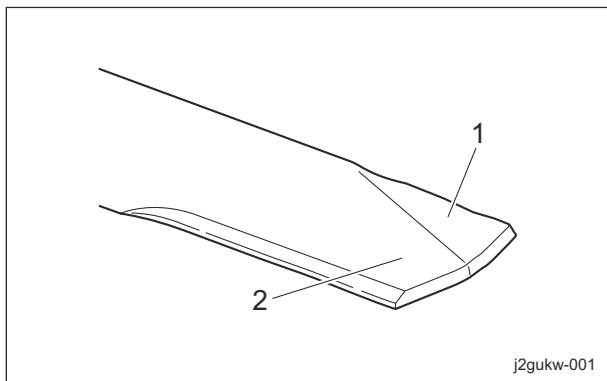

Inspection of Rotary Knife_001

1	Sail
2	Flat part

Cover

Inspection of Covers

Warning

If you have removed the shield during inspection, make sure that you re-attach it in the original position securely. If the shield remains removed, foreign objects may fly off, possibly resulting in injuries.

1. Make sure that there is no wear or deterioration in the rotary cover or shield, etc.
2. Make sure that there is no damage to the rotary cover or shield, etc.
3. Make sure that there is no interference to moving parts due to deformation of the rotary cover or shield, etc.
4. Make sure that the shield, etc., are installed in the specified locations.

Belt

Inspection of Belts

Warning

Be sure to stop the engine before inspecting the belts.

Warning

If you have removed any covers, etc., during inspection, make sure that you securely re-attach them in their original positions. If covers, etc., remain removed, the operator may come into contact with rotating parts or belts, and foreign objects may fly off, possibly resulting in injuries.

1. Press the middle of the belt with your finger to check the belt tension.
2. Make sure that there are no cracks, damage or abnormal wear.

Roller

Inspection of Rollers

1. Make sure that there is no abrasion nor adhesion of the roller.
2. Make sure that there is no wear of the roller shaft.
3. Make sure that there is no wear nor damage of the oil seal.
4. Make sure that there is no wear nor rust of the bearing.
5. Make sure that there is no play in the roller shaft.

Caster

Inspection of Casters

1. Make sure that there is no abrasion nor adhesion of the rubber wheels.
2. Make sure that there is no wear of the wheel axes.
3. Make sure that there is no damage to the wheel arms.
4. Make sure that there is no wear nor rust of the bearings.
5. Make sure that there is no play in the wheel axes.

Handling Instructions

Bolts and Nuts

Inspection of Bolts and Nuts

Important

The bolts and nuts may be loosened at the earlier stage of the use. Be sure to retighten or replace before operating the machine whenever there is any abnormality.

1. Check the bolts and nuts for looseness and coming off.
2. Check the bolts and nuts for cracks and damages.
3. Check the bolts and nuts for rust.
4. Check around the bolts and nuts for traces of rust fluid.
5. Check for unequal bolt length.
6. Check the bolts and nuts for stripped threads and abrasion.

Mower Deck

Cleaning of Contour Deck

Caution

When using a ramp, etc., apply the parking brake, and chock the tires.

Note:
Use a ramp, etc., if it is available.

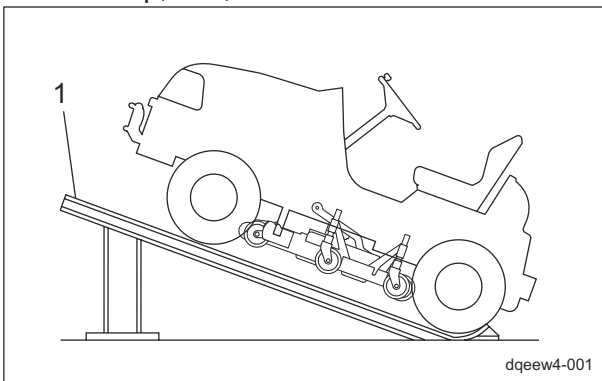

Cleaning of Contour Deck_001

1	Ramp
---	------

Important

When cleaning, do not allow water to come into contact with pulleys. Otherwise, it may cause damage to the machine.

- Be sure to clean the mower deck after use.
1. Stop the engine, and then remove the key.
 2. Carefully clean the front and back of the mower deck with water or compressed air.
 3. Remove any grass wrapped around the pulleys or rotary knives.

Storage

Short-Term Storage

Short-term storage means that the machine is temporarily stored (within 1 month) without use.

Follow the instructions below for short-term storage of the machine.

1. Cleaning
 - Remove dirt, grass clippings, oil stains etc. completely.
2. Storage location
 - Cover the machine and store it in a dry place where it will not be exposed to rain.

Handling Instructions

- Precautions for MaintenancePage 5-2**
- Greasing Page 5-2**
 - About GreasingPage 5-2
 - Greasing Points Page 5-2
- Adjustment and Replacement Page 5-4**
 - Adjustment of Cutting Height Page 5-4
 - Replacement of Rotary KnifePage 5-6
 - Grinding of Rotary Knife Page 5-8
 - Balancing of Rotary Knife Page 5-10
 - Adjustment of Belt Tension Page 5-10
 - Replacement of Gearbox Grease Page 5-11
 - Adjustment of StoppersPage 5-11
- Storage Page 5-12**
 - Long-Term StoragePage 5-12

Maintenance

Precautions for Maintenance

Warning

The chapter "Maintenance" in this manual describes practical measures which should be performed by a mechanic with expertise. The owner should instruct the mechanic with expertise to perform maintenance service for this machine.

Caution

First, learn well the operations you plan to perform.

Important

Use tools appropriate for each operation.

Important

Use Baroness genuine parts for replacement and accessories.
Our product warranty may be void if you use non-genuine parts for replacement or accessories.

Greasing

About Greasing

Since there may be adhesion or damage due to lack of grease on moving parts, they must be greased.

Add urea-based No. 2 grease in accordance with the Maintenance Schedule.

Other locations where the specified grease or lubricant is used are indicated in "Greasing Points".

Add grease using the specified grease or lubricant.

Greasing Points

Grease nipples are installed in the following locations.

Add grease every 50 hours of operation.

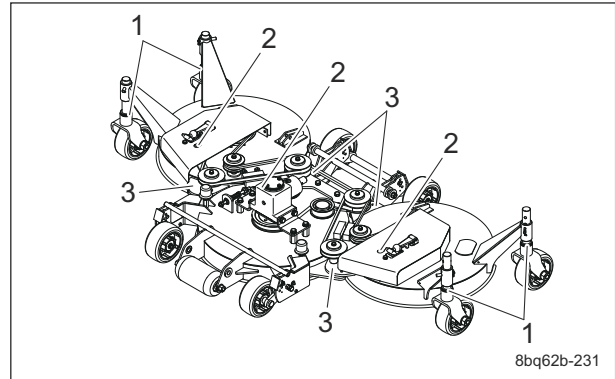

Greasing Points_001

	Location	No. of greasing points
1	Caster fulcrum	4
2	Tension lever fulcrum	3
3	Mower deck connection	4

1. Caster fulcrum

One greasing point is provided to each of the four caster fulcrums.

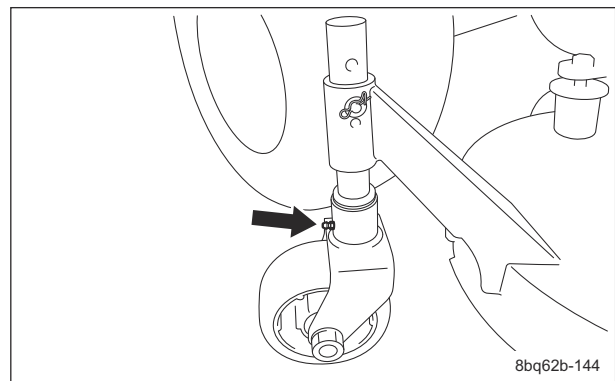

Greasing Points_002

2. Tension lever fulcrum

Left/right mower decks
One greasing point is provided to each of the right and left mower decks.

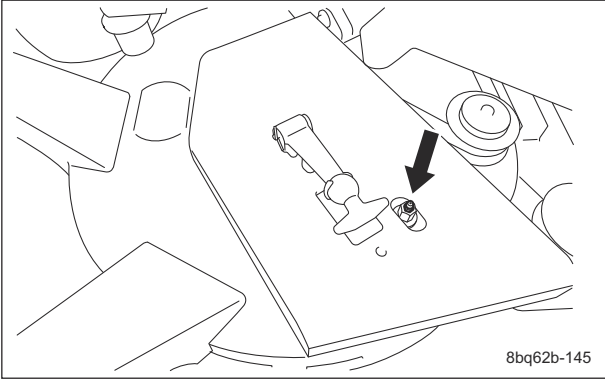

Greasing Points_003

Center mower deck

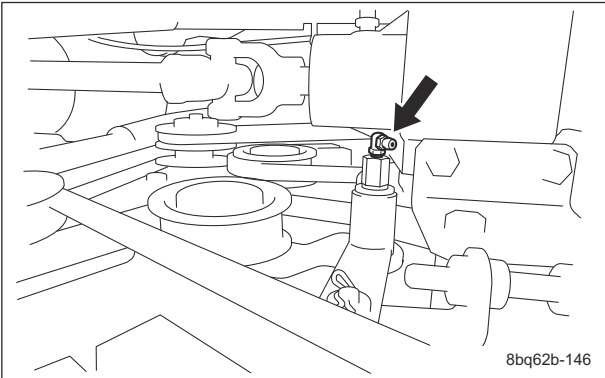

Greasing Points_004

3. Mower deck connection

One greasing point is provided to each of the four mower deck connections.

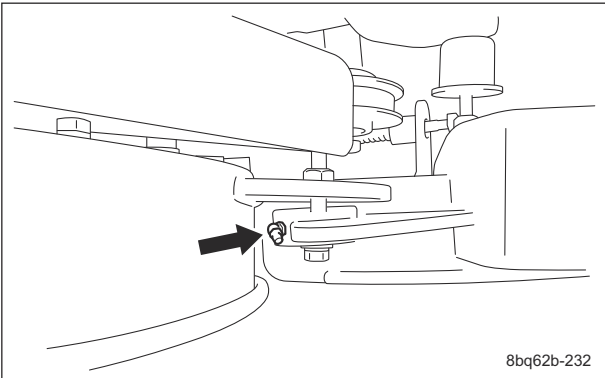

Greasing Points_005

Maintenance

Adjustment and Replacement

Adjustment of Cutting Height

Cutting Height Table

Important

Adjust all mower decks to the same cutting height.

The adjustment range for the cutting height is 35 - 95 mm (1.4 - 3.7 in) [15 mm (0.6 in) spacing, 5 levels].

Left/Right Mower Decks	Cutting Height	Center Mower Deck
A-C	95 mm (3.7 in)	e
B-D	80 mm (3.1 in)	d
A-D	65 mm (2.6 in)	c
B-E	50 mm (2.0 in)	b
A-E	35 mm (1.4 in)	a

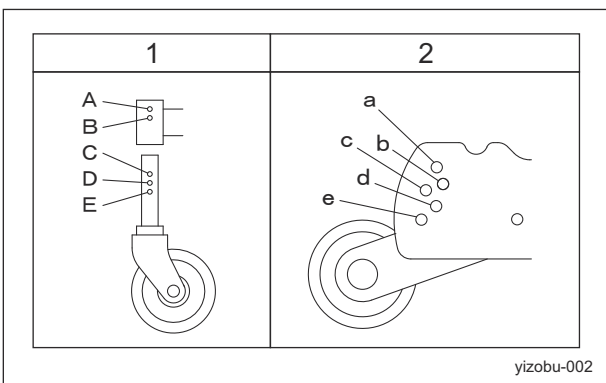

Cutting Height Table_001

1	Left/right mower decks
2	Center mower deck

The cutting height adjustment label is attached to the mower deck.

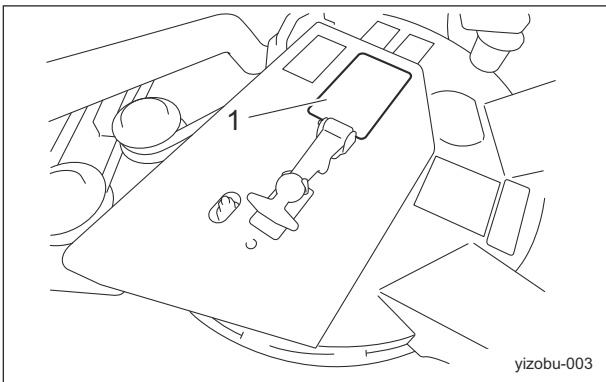

Cutting Height Table_002

1	Cutting height adjustment label
---	---------------------------------

GM1700-2161Z0

Contour deck cutting height adjustment label

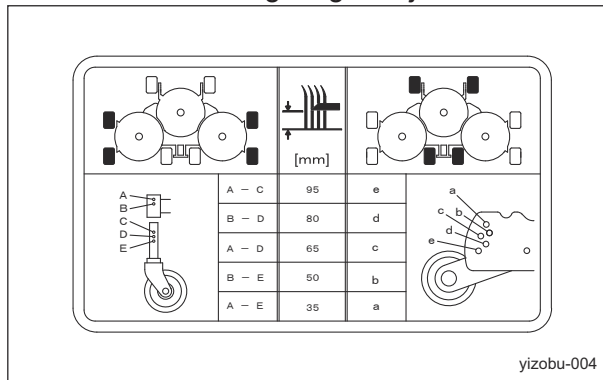

Cutting Height Table_003

Cutting Height Adjustment of Contour Deck

■ Adjustment of Center Mower Deck

The cutting height of the center mower deck is adjusted with the cutting height gauge wheels mounted at the front and back of the center mower deck.

There are four cutting height gauge wheels.

Important

The length of grass cut off at any one time must be no more than 30 mm (1.2 in).

Important

Do not cut off more than 1/3 of the grass height.

1. Apply the parking brake, and then raise the mower deck so that the cutting height gauge wheels do not touch the ground.
2. Stop the engine, and then remove the key.
3. Loosen the bolt and nut on the cutting height gauge wheel at the front of the center mower deck.

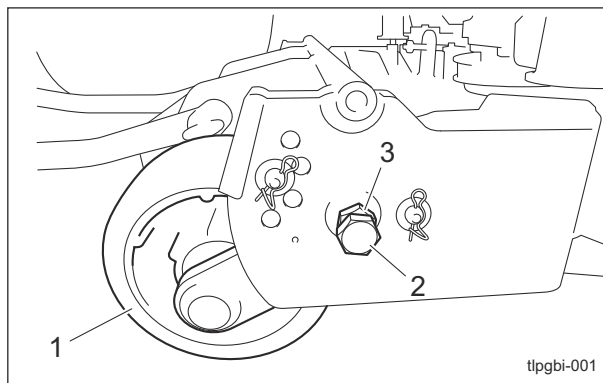

Adjustment of Center Mower Deck_001

1	Cutting height gauge wheel
2	Bolt
3	Nut

4. Remove the cotter pin and washer from the cutting height gauge wheel at the front of the center mower deck, and then remove the pin.

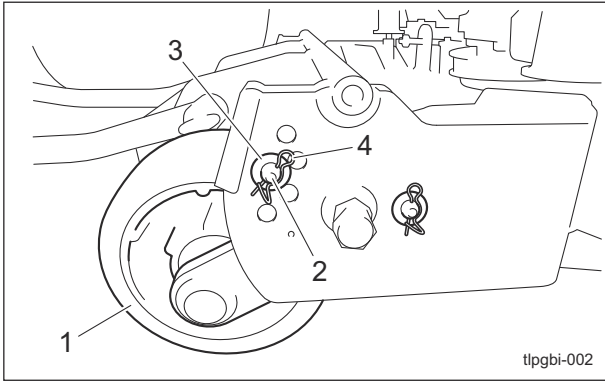

Adjustment of Center Mower Deck_002

1	Cutting height gauge wheel
2	Pin
3	Washer
4	Cotter pin

5. Refer to the Cutting Height Table, and then change the hole positions.
6. Insert the pin, and then securely install the cutting height gauge wheel with the washer and cotter pin.
7. Firmly tighten the bolt and nut to secure the wheel.
8. Remove the cotter pin and washer from the cutting height gauge wheel at the back of the center mower deck, and then remove the pin.

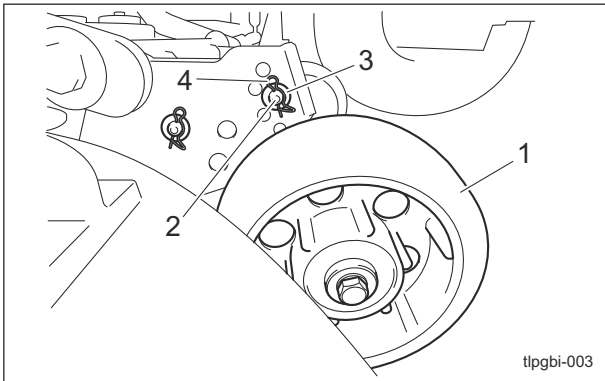

Adjustment of Center Mower Deck_003

1	Cutting height gauge wheel
2	Pin
3	Washer
4	Cotter pin

9. Refer to the Cutting Height Table, and then change the hole positions.
10. Insert the pin, and then securely install the cutting height gauge wheel with the washer and cotter pin.

■ Adjustment of Left and Right Mower Decks

The cutting heights of the left and right mower decks are adjusted with the casters mounted at the front and back of each mower deck.

There are four casters.

Important

The length of grass cut off at any one time must be no more than 30 mm (1.2 in).

Important

Do not cut off more than 1/3 of the grass height.

1. Apply the parking brake, and then raise the mower deck so that the casters do not touch the ground.
2. Stop the engine, and then remove the key.
3. Remove the cotter pin and washer from the caster, and then remove the pin.

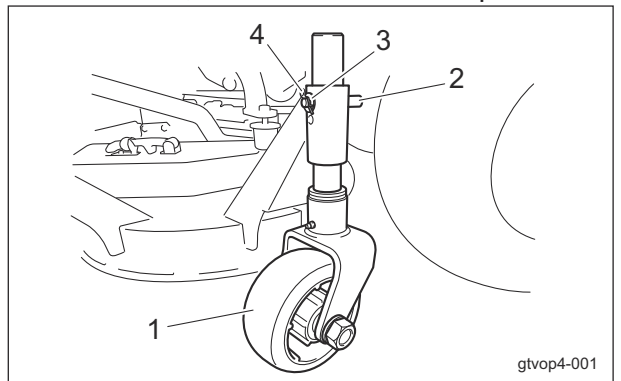

Adjustment of Left and Right Mower Decks_001

1	Caster
2	Pin
3	Washer
4	Cotter pin

4. Refer to the Cutting Height Table, and then change the hole positions.

Maintenance

5. Insert the pin, and then securely install the caster with the washer and cotter pin.

Replacement of Rotary Knife

Caution

The rotary knife is an edged tool. Take extra care in handling since they could cut your hands or legs.

Caution

If the rotary knife becomes worn or damaged, cracks or tears will occur between the sail and flat part. Broken pieces of the rotary knife may fly out while it is rotating.

Caution

Wear gloves when touching edged tools since they could cut your hands.

Important

The rotary knife has a specific installation direction. Do not install it facing the wrong direction.

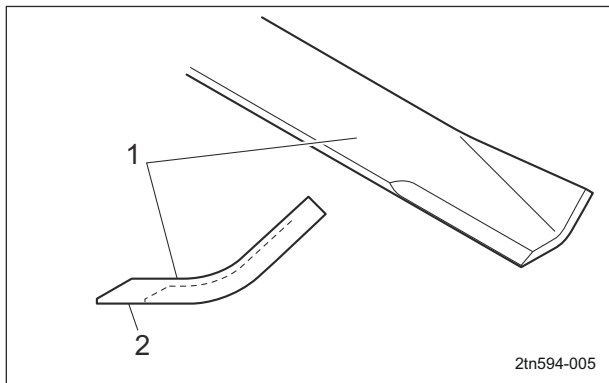

Change of Rotary Knife_001

1	Rotary knife top side
2	Rotary knife bottom side

Important

Before installing the rotary knife, make sure that it is balanced.

If the edge of the rotary knife becomes chipped or thin, replace it with a new one. The criteria for replacing the rotary knife are described below.

1. When the narrowest part of the rotary knife has a width of less than 2/3 of the width of a new knife

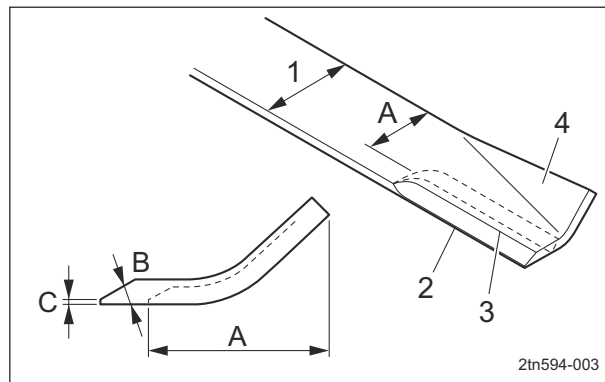

Change of Rotary Knife_002

1	Total width
2	Blade edge
3	Blade base
4	Sail
A	less than 2/3
B	30 - 40 °
C	0.5 - 1.0 mm (0.02 - 0.04 in)

2. When the thinnest part of the rotary knife has a thickness of less than 1/3 of the thickness of a new knife

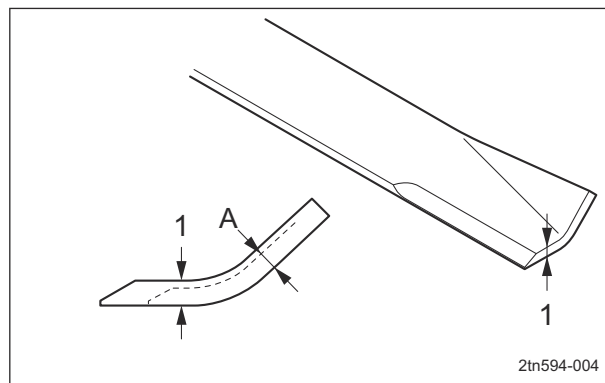

Change of Rotary Knife_003

1	Thickness
A	less than 1/3

Contour Deck

⚠ Caution

When using a ramp, etc., apply the parking brake, and chock the tires.

Note:
Use a ramp, etc., if it is available.

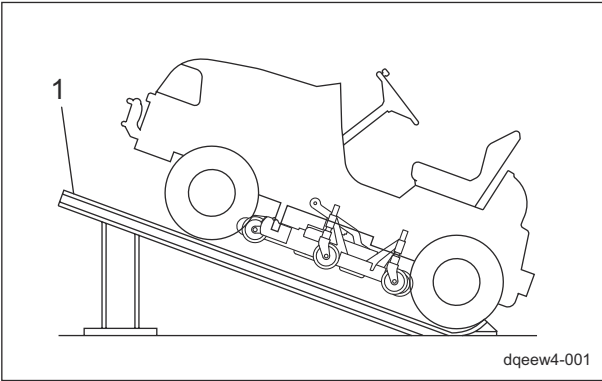

Contour Deck_001

1	Ramp
---	------

1. Start the engine, and then raise the mower deck.

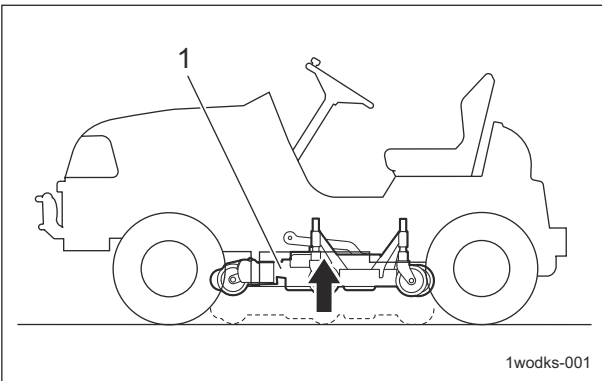

Contour Deck_002

1	Mower deck
---	------------

2. Stop the engine, and then remove the key.

3. Follow the steps below to remove the rotary knife.

[1] Use the square pipe from the included tools to secure the rotary knife so that it does not turn.

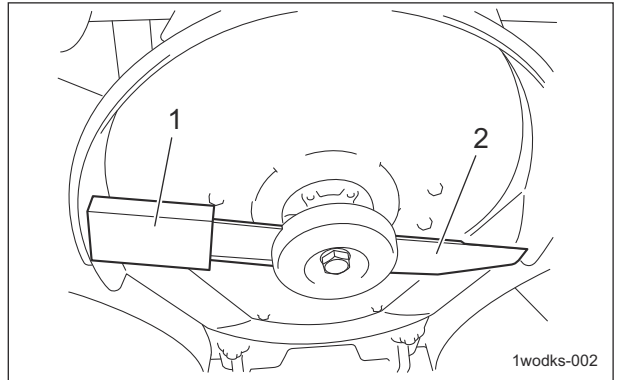

Contour Deck_003

1	Square pipe
2	Rotary knife

[2] Slide the pipe for the offset wrench onto the offset wrench from the included tools.

[3] Remove the bolt, washer and disc spring used to install the rotary knife.

[4] Remove the knife guide disc.

[5] Remove the rotary knife.

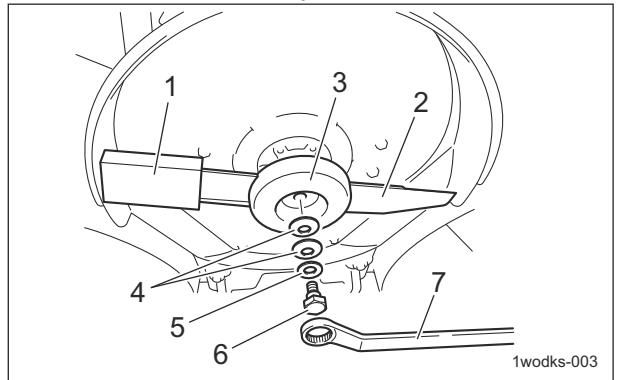

Contour Deck_004

1	Square pipe
2	Rotary knife
3	Knife guide disc
4	Disc spring
5	Washer
6	Knife mounting bolt
7	Offset wrench

Maintenance

Important

The disc spring has a specific installation orientation. Do not install it facing the wrong direction.

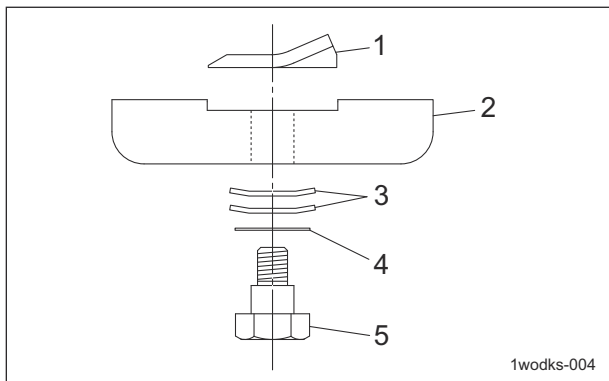

Contour Deck_005

1	Rotary knife
2	Knife guide disc
3	Disc spring
4	Washer
5	Knife mounting bolt

Important

The tightening torque for the knife mounting bolt is 130 - 150 N-m (1,325.61 - 1,529.55 kgf-cm).

4. Install the rotary knife.
For installing the rotary knife, reverse the removing procedure.

Grinding of Rotary Knife

Caution

The rotary knife is an edged tool. Take extra care in handling since they could cut your hands or legs.

Caution

Wear gloves when touching edged tools to avoid cutting your hands.

Caution

If the rotary knife becomes worn or damaged, cracks or tears will occur between the sail and flat part. Broken pieces of the rotary knife may fly out while it is rotating.

Caution

When grinding the rotary knife, be sure to wear safety glasses and gloves.

Important

Using an imbalanced rotary knife will cause vibrations, resulting in damage to the machine.

When the edge of the rotary knife becomes rounded and no longer cuts well, sharpen the worn cutting edge with a grinder or sander. If the edge of the rotary knife becomes chipped or thin, replace it with a new one. The criteria for grinding the rotary knife are described below.

1. When, after grinding, the width of the rotary knife to the blade edge is 2/3 or more of the total width of a new knife
2. When, after grinding, the blade base of the rotary knife does not reach the sail

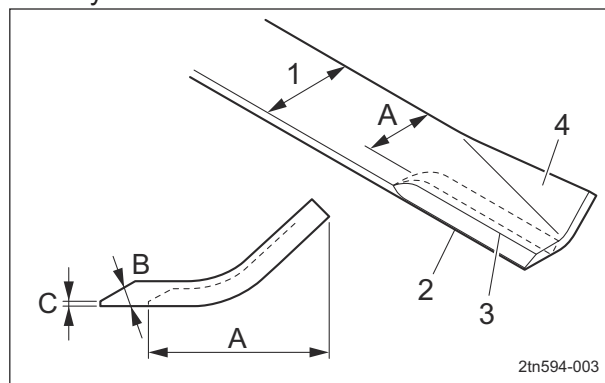

Grinding of Rotary Knife_001

1	Total width
2	Blade edge
3	Blade base
4	Sail
A	2/3 or more
B	30 - 40 °
C	0.5 - 1.0 mm (0.02 - 0.04 in)

3. When the thinnest part of the rotary knife has a thickness of 1/3 or more of the thickness of a new knife

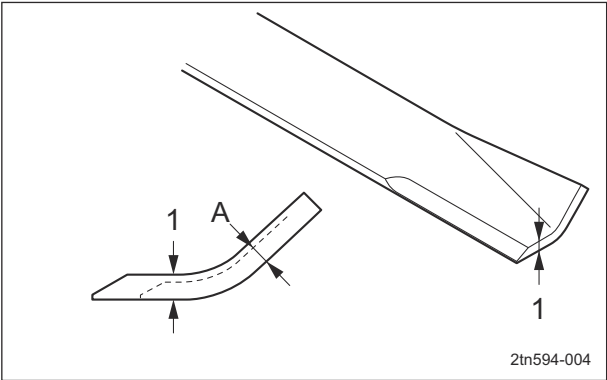

Grinding of Rotary Knife_002

1	Thickness
A	1/3 or more

Follow the steps below to grind the rotary knife.

1. Remove the rotary knife from the mower deck.

"Replacement of Rotary Knife" (Page 5-6)

Important

Grind only the top surface of the edge, and be sure to maintain the original angle. By equally grinding the left and right ends of the rotary knife, it can be sharpened without becoming imbalanced.

2. Grind the cutting edge of the rotary knife. Grind so that the edge angle is 30 - 40 degrees, the point thickness is 0.5 - 1.0 mm (0.02 - 0.04 in), and the blade base does not reach the sail.

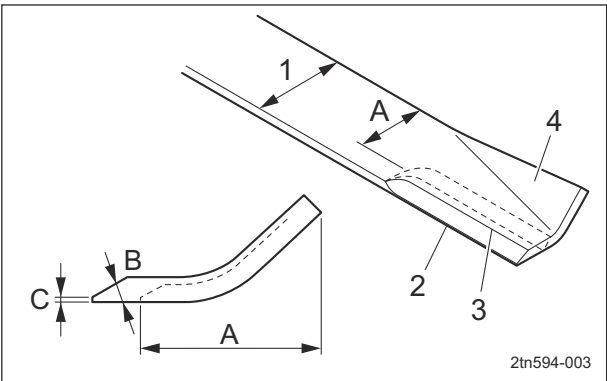

Grinding of Rotary Knife_003

1	Total width
2	Blade edge
3	Blade base
4	Sail
A	2/3 or more
B	30 - 40 °
C	0.5 - 1.0 mm (0.02 - 0.04 in)

- 3. Balance the rotary knife.
"Balancing of Rotary Knife" (Page 5-10)
- 4. If it is not balanced, repeat steps 2. - 3.

Maintenance

Balancing of Rotary Knife

Caution

The rotary knife is an edged tool. Take extra care in handling since they could cut your hands or legs.

Caution

When touching edged tools, wear gloves since they could cut your hands.

Important

Using an imbalanced rotary knife will cause vibrations, resulting in damage to the machine.

When the rotary knife is worn asymmetrically, causing vibrations, or when it becomes dull or worn, remove the rotary knife from the mower deck and balance it.

Follow the steps below to balance the rotary knife.

1. Remove the rotary knife from the mower deck.
"Replacement of Rotary Knife" (Page 5-6)
2. Install the balancer equipment in an appropriate location.
3. Fit the hole at the center of the rotary knife onto the balancer equipment, and then balance the left and right ends so that the rotary knife is level.

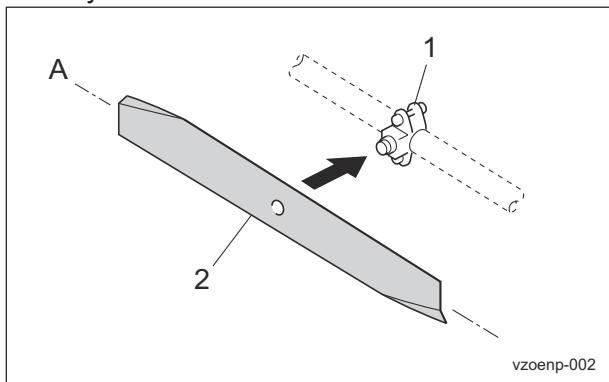

Balancing of Rotary Knife_001

1	Balancer equipment
2	Rotary knife
A	Level

Adjustment of Belt Tension

Warning

Be sure to stop the engine before adjusting the belts.

Important

For the specified value of belt tension, refer to Adjusted Values.

Before making sure of belt tension, rotate the belt several times.

Adjustment of Center Mower Deck Belt

1. Check the belt tension.
2. If the belt tension is not appropriate, adjust the length of the tension spring by tightening the nut.
The approximate length of the tension spring is 35 mm (1.38 in) from the end of the spring guide. (Compress the spring by 5.0 mm (0.2 in).)

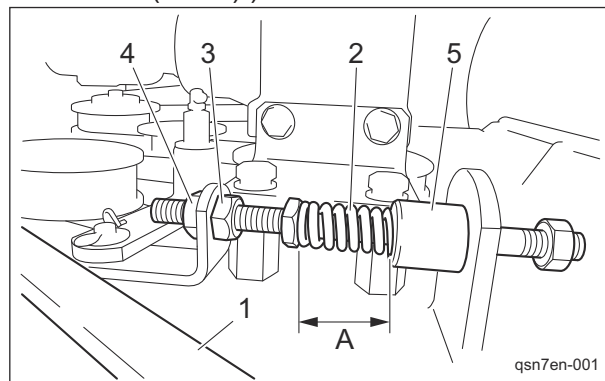

Adjustment of Center Mower Deck Belt_001

1	Belt
2	Tension spring
3	Nut
4	Lock nut
5	Spring guide
A	35 mm (1.38 in)

Adjustment of Left and Right Mower Deck Belts

1. Remove the belt cover.
2. Check the belt tension.
3. If the belt tension is not appropriate, adjust the length of the tension spring by tightening the nut.
The approximate length of the tension spring is 35 mm (1.38 in) from the end of the spring guide. (Compress the spring by 5.0 mm (0.2 in).)

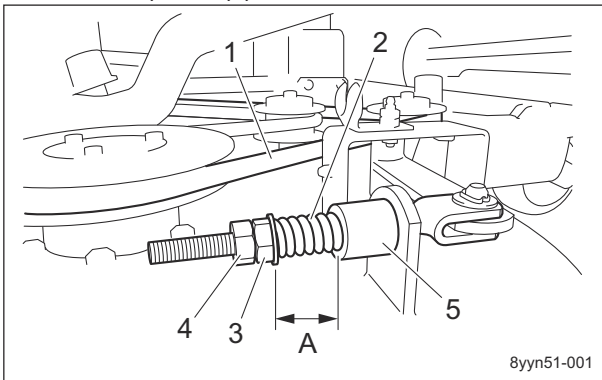

Adjustment of Left and Right Mower Deck Belts_001

1	Belt
2	Tension spring
3	Nut
4	Lock nut
5	Spring guide
A	35 mm (1.38 in)

4. Install the belt cover.

Replacement of Gearbox Grease

Important

Use the specified grease.

Change the gearbox grease in accordance with the Maintenance Schedule. Disassemble the gearbox and change all of the grease. The grease to be used is listed below.

Gearbox	Pyronoc CC 0	260 g (9.17 oz)
---------	--------------	-----------------

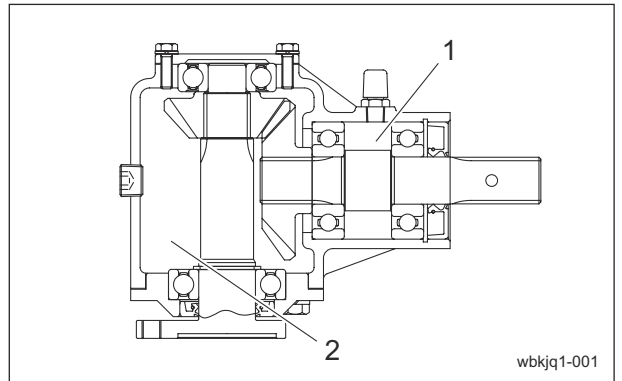

Replacement of Gearbox Grease_001

1	20 g Pyronoc CC 0 (0.71 oz)
2	240 g Pyronoc CC 0 (8.47 oz)

Adjustment of Stoppers

The rubber stoppers may wear or deteriorate due to frequent use and may no longer perform as expected. If necessary, adjust the stoppers.

Swing Stoppers

The swing stoppers fulfill the role of suppressing swing when the mower deck is raised while keeping the mower deck horizontal by lever action. There are two installed, one each on the left and the right.

1. Temporarily tighten the rubber stopper in the direction away from the mower deck.
2. Raise the mower deck.
3. Make sure that the right and left mower decks are equally raised.

Note:

If the decks are not equally raised, adjust the installation position of the link fulcrum shafts.

Maintenance

Important

Adjust the rubber stoppers on the left and right mower decks so that they make contact equally and so that the left and right mower decks are level.

4. Adjust the contact for the rubber stoppers, and then lock them with the nuts.

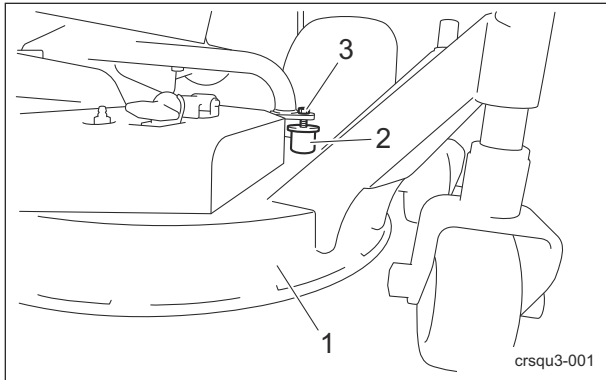

Swing Stoppers_001

1	Mower deck
2	Rubber stopper
3	Nut

1	Main vehicle (link fulcrum shaft)
2	Rubber stopper
3	Nut

· Right side of deck tow plate

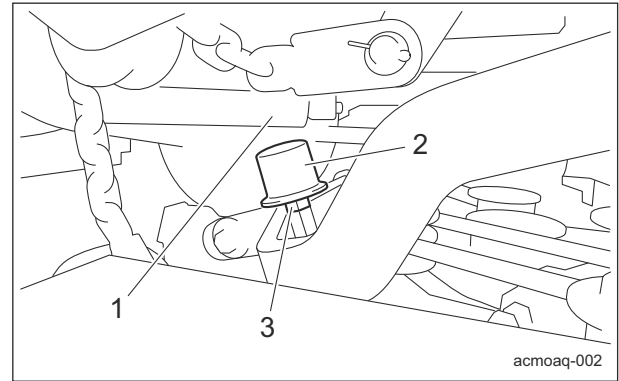

Lift Stoppers_002

1	Main vehicle
2	Rubber stopper
3	Nut

Storage

Long-Term Storage

Follow the instructions below for long-term storage of the machine.

1. Cleaning
 - Remove dirt, grass clippings, oil stains etc. completely.
2. Oil filling
 - Grease and lubricate the appropriate points.
3. Storage location
 - Cover the machine and store it in a dry place where it will not be exposed to rain.

Lift Stoppers

The lift stoppers fulfill the role of preventing interference between the mower deck and the main vehicle.

There are three installed.

1. Raise the mower deck.
2. Make sure that all mower decks are raised horizontally.
3. Adjust the rubber stoppers so that they slightly come into contact with the main vehicle, and then lock them with the nuts.
 - Left and right sides of front of center mower deck

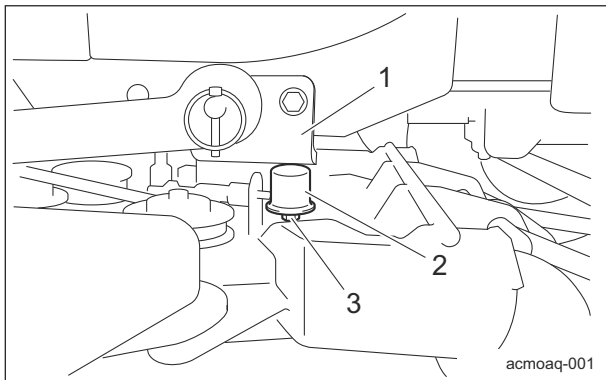

Lift Stoppers_001

Appended Table

- Tightening TorquesPage 6-2**
 - Standard Tightening TorquesPage 6-2
 - Principal Tightening Torques Page 6-4
- Maintenance Schedule Page 6-5**
- List of Adjusted Values Page 6-5**



Appended Table

Appended Table

Tightening Torques

Important

Refer to the Tightening Torque table.
Note that the Baroness product warranty may not apply to defects caused by incorrect or overtorque tightening, etc.

Standard Tightening Torques

Bolts and Nuts

Important



A number of bolts are used in each part of this machine.
Be sure to re-tighten the bolts and nuts, because they may be loosened at the earlier stage of the use.

- As to the bolts and nuts without any special instruction, tighten them in appropriate tightening torque with proper tool.
Too much tightening may cause the looseness or damage of the screw.
- The strength of tightening is determined by types of screws, strength, the friction of thread face or base face and others.
The table below is for the galvanized or parkerized bolts.
In case that the strength of internal thread is weak, it is not applied.
- Do not use rusty or sand attached "screw."
Otherwise, it may cause insufficient tightening even if you apply the specified tightening torque.
The friction of the screw face becomes higher and the tightening torque is canceled out by the friction, therefore sufficient tightening cannot be applied.
- If "screw" is wet by water or oil, do not tighten it with normal tightening torque.
If the screw is wet, the torque coefficient will get smaller and it may result in too much tightening.
Too much tightening may cause looseness by the screw stretched or result in damage.
- Do not use a bolt experienced too much burden.
- Using the impact wrench requires the skill.
Do exercise as much as possible for steady tightening.

Appended Table

Appended Table

Nominal diameter	General bolt		
	Strength classification 4.8		
	 tib3yb-001		
	N-m	kgf-cm	lb-in
M5	3 - 5	30.59 - 50.99	26.55 - 44.26
M6	7 - 9	71.38 - 91.77	61.96 - 79.66
M8	14 - 19	142.76 - 193.74	123.91 - 168.17
M10	29 - 38	295.71 - 387.49	256.68 - 336.34
M12	52 - 67	530.24 - 683.20	460.25 - 593.02
M14	70 - 94	713.79 - 958.52	619.57 - 831.99
M16	88 - 112	897.34 - 1142.06	778.89 - 991.31
M18	116 - 144	1,182.85 - 1,468.37	1,026.72 - 1,274.54
M20	147 - 183	1,498.96 - 1,866.05	1,301.10 - 1,619.73
M22	295	3,008.12	2,611.05
M24	370	3,772.89	3,274.87
M27	550	5,608.35	4,868.05
M30	740	7,545.78	6,549.74

Nominal diameter	Heat-treated bolt					
	Strength classification 8.8			Strength classification 10.9		
	 tib3yb-002			 tib3yb-003		
	N-m	kgf-cm	lb-in	N-m	kgf-cm	lb-in
M5	5 - 7	50.99 - 71.38	44.26 - 61.96	7 - 10	71.38 - 101.97	61.96 - 88.51
M6	8 - 11	81.58 - 112.17	70.81 - 97.36	14 - 18	142.76 - 183.55	123.91 - 159.32
M8	23 - 29	234.53 - 295.71	203.57 - 256.68	28 - 38	285.52 - 387.49	247.83 - 336.34
M10	45 - 57	458.87 - 581.23	398.30 - 504.51	58 - 76	591.43 - 774.97	513.36 - 672.68
M12	67 - 85	683.20 - 866.75	593.02 - 752.34	104 - 134	1,060.49 - 1,366.40	920.50 - 1186.03
M14	106 - 134	1,080.88 - 1,366.40	938.21 - 1,186.03	140 - 188	1,427.58 - 1,917.04	1,239.14 - 1,663.99
M16	152 - 188	1,549.94 - 1,917.04	1,345.35 - 1,663.99	210 - 260	2,141.37 - 2,651.22	1,858.71 - 2,301.26
M18	200 - 240	2,039.40 - 2,447.28	1,770.20 - 2,124.24	280 - 340	2,855.16 - 3,466.98	2,478.28 - 3,009.34
M20	245 - 295	2,498.27 - 3,008.12	2,168.50 - 2,611.05	370 - 450	3,772.89 - 4,588.65	3,274.87 - 3,982.95
M22	-	-	-	530	5,404.41	4,691.03
M24	-	-	-	670	6,831.99	5,930.17
M27	-	-	-	1,000	10,197.00	8,851.00
M30	-	-	-	1,340	13,663.98	11,860.34

Note:
The same values are applied to "fine screw thread."

Appended Table

Principal Tightening Torques

Tightening Torque by Model

GM1700_Contour deck

Tighten the following bolts and nuts at the torque specified in the table.

For thread locking adhesive, apply a middle strength thread locker (ThreeBond 1322 or equivalent anaerobic sealant).

Location	Code	Part name	Tightening torque			Thread locking adhesive
			N-m	kgf-cm	lb-in	
Link fulcrum shaft	K0013100802	Bolt, heat-treated M10-80	29 - 38	295.71 - 387.49	256.68 - 336.34	—
Center knife shaft	K0017100251	Bolt, heat-treated, small, 10-25 P1.25	45 -57	458.87 - 581.23	398.30 - 504.51	○
Rotary knife shaft	K0010100251	Bolt, heat-treated M10-25	58 -76	591.43 - 774.97	513.36 - 672.68	○
Rotary knife	GM1700-2149Z1	Knife mounting bolt	130 - 150	1,325.61 - 1,529.55	1,150.63 - 1,327.65	—
Mower deck connector	K0010100202	Bolt, heat-treated M10-20	58 – 76	591.43 - 774.97	513.36 - 672.68	—
Stopper arm	K0013080502	Bolt, heat-treated M8-50	14 - 19	142.76 - 193.74	123.91 - 168.17	—
Tension pulley	GM1700-2187Z8	Pin, tension LH-thread for cener cover	70 - 94	713.79 - 958.52	619.57 - 831.99	○
	GM1700-2188Z8	Pin, tension RH-thread for left cover	70 - 94	713.79 - 958.52	619.57 - 831.99	○
	GM1700-2189Z8	Pin, tension LH-thread for right cover	70 - 94	713.79 - 958.52	619.57 - 831.99	○

Appended Table

Maintenance Schedule

Standard Deck for GM1700
 Contour Deck for GM1700
 Mulching Deck for GM1700

- . . . Inspect, adjust, supply, clean (first time)
- . . . Inspect, adjust, supply, clean
- ▲ . . . Replace (first time)
- △ . . . Replace

Maintenance Item		Before work	After work	Every 8 hrs.	Every 10 hrs.	Every 50 hrs.	Every 100 hrs.	Every 200 hrs.	Every 250 hrs.	Every 300 hrs.	Every 400 hrs.	Every 500 hrs.	Every year	Every 2 years	Every 3 years	Every 4 years	Remarks
Mower Deck	Tightening the parts	○															
	Knife	○															
	Cutting height	○															
	Greasing, oiling					○											
	Cutting height gauge wheel	○															
	V-belt	○											△				
	Cover	○															
	Grease (gearbox)												△				
	Cleaning the exterior		○														

· The values for consumables are not guaranteed.

List of Adjusted Values

Center mower deck belt	Spring extends 35 mm (1.38 in) from end of spring guide	Compress the spring by 5 mm (0.2 in)
Left and right mower deck belts	Spring extends 35 mm (1.38 in) from end of spring guide	Compress the spring by 5 mm (0.2 in)

Appended Table

Appended Table

Maintenance RecordsPage 7-2

Records

Records

Maintenance Records

Standard Deck for GM1700

Contour Deck for GM1700

Mulching Deck for GM1700

Use this table freely for your records of the maintenance.

Model		Serial Number	
-------	--	---------------	--

	Items									
Mower Deck	Tightening the parts									
	Knife									
	Cutting height									
	Greasing, oiling									
	Cutting height gauge wheel									
	V-belt									
	Cover									
	Grease (gearbox)									
	Cleaning the exterior									

BARONESS[®]
Quality on Demand

 **KYOEISHA CO., LTD.**
Head Office 1-26, Miyuki-cho, Toyokawa-city, Tel :+81-533-84-1390
Aichi-pref, 442-8530 JAPAN Fax:+81-533-84-1220