

FS900

Riding Sweeper

Owner's Operating Manual

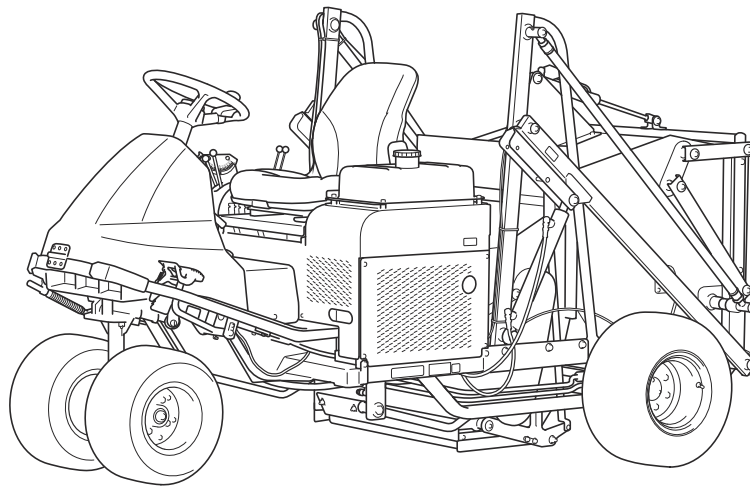

Serial No. FS900 : 11299-

"Required reading"
Read this manual before using the machine.

BARONESS[®]
Quality on Demand

Original Instructions Ver.3.1

FS900

Regulations

EU Regulations

(For EU)

This product complies with all relevant EU Regulations.

For more information, please refer to the Declaration of Conformity attached.

Thank you for purchasing the Baroness product. This manual describes the proper handling, adjustment, and inspection of your product. We hope you will use the product safely, and take advantage of its best performance.

Keeping The Owner's Operating Manual

Keep this Owner's Operating Manual in the box behind the seat.

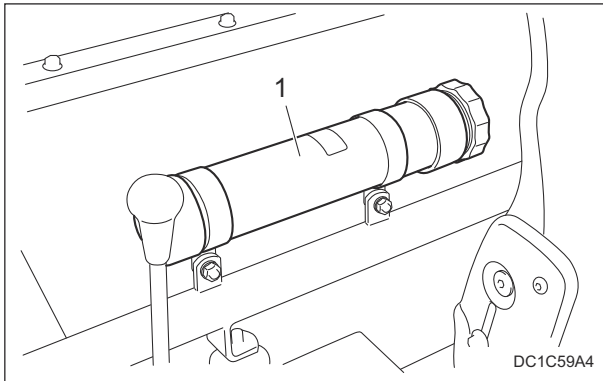

Keeping The Owner's Operating Manual_001

1	Box
---	-----

QR Code

(*QR Code is a registered trademark of DENSO WAVE INCORPORATED.)

A QR code label is affixed on the machine.

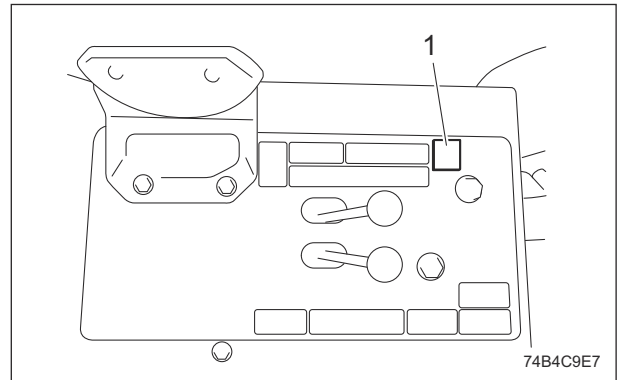

QR Code_001

1	QR code label
---	---------------

Scan the QR code with your smartphone for easy access to Baroness Manual Reference Service where you can browse Owner's Operating Manual and Parts Catalog.
<https://doc.baroness-international.com/manuals/FS900>



QR Code_002

Introduction

Read this manual carefully to ensure that you thoroughly understand how to properly operate and maintain the product, and to avoid causing injury to yourself or others.

The operator is responsible for operating the product properly and safely.

Maintenance service for this machine should be performed by a mechanic with expertise.

If you have any questions concerning maintenance or genuine parts, please contact a Baroness dealer or Kyoisha.

When making inquiries about your product, please specify the model and serial number.

When loaning or transferring the product, please also provide this manual together with the product.

Kyoisha Co., Ltd.

Warning Symbols

This manual uses the following warning symbols for handling precautions that are important for your safety.



696cq5-001

Warning symbol

This symbol indicates the articles regarding “Danger,” “Warning,” or “Caution.”

Those articles describe important safety precautions and so read them carefully to understand completely before operating the machine.

Failure to adequately follow these safety precautions may cause an accident.

Danger

This symbol indicates that serious injury or death will occur if the warning is ignored.

Warning

This symbol indicates that serious injury or death may occur if the warning is ignored.

Caution

This symbol indicates that injury or damage to property may occur if the warning is ignored.

Important

This symbol indicates precautions on the mechanism of the machine.

Precautionary Statement

Caution

The information described in this manual is subject to change for improvement without prior notice.

When replacing parts, be sure to use genuine Baroness parts or parts designated by Kyoisha.

Note that the Baroness product warranty may not apply to defects caused by the use of parts from other companies.

Prior to use, carefully read the following manuals to thoroughly understand the contents for safe and correct operation.

- Baroness Owner's Operating Manual
- The Engine's Owner's Manual
- The Battery's Owner's Manual

Purpose

This product is intended for sweeping at golf courses.

Do not use this product in any way other than its intended purpose, and do not modify this product.

Operating this product for other purposes and modifying it may be very dangerous and may cause damage to the product.

In addition, this product is not authorized for operation as a special motor vehicle. Do not operate it on public roads.

FS900

Introduction

Contents

Safety	Page 1-1	Maintenance	Page 6-1
Safe Operating Practices	Page 1-2	Precautions for Maintenance	Page 6-2
Disposal	Page 2-1	Jacking Up The Machine	Page 6-2
Recycle and Waste Disposal	Page 2-2	Inspection and Cleaning	Page 6-3
Product Overview	Page 3-1	Supplying Fluids	Page 6-5
Specifications	Page 3-2	Greasing	Page 6-8
Names of Each Section	Page 3-4	Lubrication	Page 6-12
Regulation Decals	Page 3-6	Adjustment	Page 6-13
Safety Signs and Instruction Signs	Page 3-9	Replacement	Page 6-18
Operation Decals	Page 3-14	Storage	Page 6-28
Description of Functions	Page 4-1	Repair	Page 7-1
Traveling Pedal	Page 4-2	Precautions for Repair	Page 7-2
Brake Pedal	Page 4-2	Adjustment and Replacement	Page 7-2
Tilt Lever	Page 4-2	Towing	Page 7-5
Key Switch	Page 4-3	Appended Table	Page 8-1
Throttle Lever	Page 4-3	Tightening Torques	Page 8-2
Choke Lever	Page 4-3	Daily Check List	Page 8-6
Bucket Buzzer Switch	Page 4-3	Maintenance Schedule	Page 8-7
Brush Up/Down Lever	Page 4-4	List of Adjusted Values	Page 8-8
Brush Rotation Lever	Page 4-4	Records	Page 9-1
Stop Valve	Page 4-4	Daily Check Records	Page 9-2
Bucket Up/Down Lever	Page 4-5	Maintenance Records	Page 9-5
Bucket Open/Close Lever	Page 4-6		
Roller Press Lever	Page 4-6		
Outrigger	Page 4-7		
Instruments on The Operation Panel	Page 4-8		
Angle Meter	Page 4-8		
Safety Device	Page 4-9		
Warning Mechanisms	Page 4-9		
Handling Instructions	Page 5-1		
Operations before Service	Page 5-2		
Inspection before Use	Page 5-5		
Adjustment before Work	Page 5-11		
Mounting and Dismounting	Page 5-12		
Start/Stop of Engine	Page 5-13		
Parking and Stopping	Page 5-14		
Move	Page 5-14		
Operations	Page 5-14		
Transporting	Page 5-17		
Cleaning after Use	Page 5-17		
Storage	Page 5-18		

FS900

Contents

Safe Operating Practices Page 1-2

Training Page 1-2

Preparation Page 1-2

Operation Page 1-3

Maintenance Page 1-4

Storage Page 1-4



Safety

Failure to adequately follow these safety precautions may cause an accident resulting in injury or death.

Danger

This product is designed to ensure safe operation and has been tested and inspected thoroughly before shipment from the factory. The product is equipped with safety devices to prevent accidents.

However, whether the product demonstrates its original performance level depends on the manner in which it is operated and handled, as well as the manner in which it is managed on a daily basis.

Inappropriate use or management of the product may result in injury or death.

Observe the following safety instructions to ensure safe operation.

Safe Operating Practices

Training

1. Read this manual and other training material carefully.

Be familiar with the controls, safety signs, and the proper use of the equipment.

2. If the operator or mechanic can not read the language used in this manual, it is the owner's responsibility to explain this material to them.

3. All operators and mechanics should seek and obtain professional and practical instruction.

The owner is responsible for training the users.

Such instruction should emphasize:

- [1] The need for care and concentration when working with ride-on machines.

- [2] Control of a ride-on machine sliding on a slope will not be regained by the application of the brake.

The main reasons for loss of control are

- Insufficient wheel grip
- Being driven too fast
- Inadequate braking
- The type of machine is unsuitable for its task
- Lack of awareness of the effect of ground conditions, especially slopes
- Incorrect hitching and load distribution

4. Never allow children or people unfamiliar with these instructions to use or service the machine.

Local regulations may restrict the age of the operator.

5. The owner/user can prevent and is responsible for accidents or injuries occurring to themselves, other people, or property.
6. Keep in mind that the owner, operator, and mechanic are responsible for accidents or hazards occurring to other people or their property.
7. You can find additional safety information where needed throughout this manual.
8. Determine the left and right sides of the machine from the normal operating position.

Preparation

1. Evaluate the terrain to determine what accessories and attachments are needed to properly and safely perform the job. Only use accessories and attachments approved by the manufacturer.
2. While operating, always wear substantial footwear, long trousers, hard hat, safety glasses, mask, and ear protection. Long hair, loose clothing, or jewelry may get tangled in moving parts. Do not operate the equipment when barefoot or wearing open sandals.
3. Inspect the area where the equipment is to be used and remove all objects such as rocks, toys and wire which can be thrown by the machine.
4. Keep children out of the operating area and under the watchful care of a responsible adult other than the operator.
5. Exercise care in the handling of fuel.

Warning

Fuel is highly flammable.

Take the following precautions:

- [1] Store fuel in containers specifically designed for this purpose.
- [2] Add fuel before starting the engine. Never remove the cap of the fuel tank or add fuel while the engine is running or when the engine is hot.
- [3] Refuel outdoors only and do not smoke while refueling.

- [4] If fuel is spilled, do not attempt to start the engine but move the machine away from the area of spillage and avoid creating any source of ignition until petrol vapours have dissipated;
- [5] Replace all fuel tanks and container caps securely.
- 6. Check that operator's presence controls, safety switches and shields are attached and functioning properly.
Do not operate unless they are functioning properly.
- 7. If the brake operation is faulty, be sure to adjust or repair them before operating the machine.
- 8. Replace faulty mufflers.

Operation

- 1. Do not operate the machine under the influence of alcohol or drugs.
- 2. Do not operate the engine in a confined space where dangerous carbon monoxide fumes can collect.
- 3. Be sure all drives and shift are in neutral and parking brake is engaged before starting engine.
Only start engine from the operator's position.
Use seat belts if provided.
- 4. Do not change the engine governor settings or overspeed the engine.
Operating the engine at excessive speed may increase the hazard of personal injury.
- 5. Never operate the machine with damaged guards, shields, or without safety protective devices in place.
Be sure all interlocks are attached, adjusted properly, and functioning properly.
- 6. Keep hands and feet away from the rotating parts.
- 7. Do not carry passengers.
- 8. Never operate while people, especially children, or pets are nearby.
- 9. Only operate in good light, keeping away from holes and hidden hazards.
- 10. Do not operate the machine when there is the risk of lightning.
- 11. Do not stop or start suddenly.
- 12. Look behind and down before backing up to be sure of a clear path.

- 13. Slow down and use caution when making turns and crossing roads and sidewalks.
- 14. Use care when approaching blind corners, shrubs, trees, or other objects that may obscure vision.
- 15. Do not take your eyes off the road ahead.
Do not operate the machine with no hands.
- 16. Remember there is no such thing as a safe slope.
Travel on grass slopes requires particular care.
To guard against overturning, follow these instructions.
 - [1] Do not stop or start suddenly when going up or downhill.
 - [2] Engage clutch slowly, always keep machine in gear, especially when traveling downhill.
 - [3] Machine speeds should be kept low on slopes and during turns.
 - [4] Stay alert for humps and hollows and other hidden hazards.
- 17. Never use the machine on a slope with an angle of gradient that is greater than that specified or in a place where there is a danger of the machine slipping.
- 18. Disengage drive to the mechanical equipment section, when other than operating.
- 19. Do the following before leaving the operator's position.
 - [1] Stop on level ground.
 - [2] Disengage the all drives.
 - [3] Lower the bucket.
 - [4] Set the parking brake.
 - [5] Stop the engine.
 - [6] Remove the ignition key.
- 20. Stop the engine in the following conditions.
 - [1] Before refuelling.
 - [2] Before making height or depth adjustment unless adjustment can be made from the operator's position.
 - [3] Before clearing blockages.
 - [4] Before checking, cleaning or working on the machine.
 - [5] After striking a foreign object or if an abnormal vibration occurs.
Inspect the machine for damage and make repairs before restarting and operating the equipment.

Safety

21. Reduce the throttle setting during engine run-out.
22. Take care when loading or unloading the machine into a trailer or a truck.
Load or unload the machine in a flat and safe place.
Before loading or unloading, set the parking brake on the truck or trailer, stop the engine, and chock the wheels.
When transporting the machine on a truck or a trailer, set the parking brake, stop the engine, and fasten the machine to the truck with a rope or other suitable restraining device that has sufficient strength.
When using a running board, select one with sufficient strength, length, and width and that will not cause the machine to slip.
23. Close the fuel valve before transporting the machine.
8. Keep hands and feet away from moving parts.
If possible, do not make adjustments with the engine running.
9. Make sure that parts such as wires are not touching each other and that their covers have not come off.
10. Keep all parts in good working condition and all hardware tightened.
Replace all worn or damaged decals.
11. Keep all nuts, bolts and screws tight to be sure the equipment is in safe working condition.
12. Carefully release pressure from components with stored energy.
13. Be sure to depressurize the hydraulic system before performing maintenance operations on it such as removing hydraulic equipment.
14. Check whether line connectors in the hydraulic system are properly tightened.
Before applying hydraulic pressure, check the connections of the hydraulic pressure lines and the condition of the hoses.
15. When checking the hydraulic circuit for pinhole leaks or oil leakage from nozzles, do not use your hands.
Use items such as paper or corrugated cardboard to find leakage points.
Be extremely careful with high-pressure oil as it may pierce your skin, resulting in an injury.
If fluid is injected into the skin it must be surgically removed within a few hours by a doctor familiar with this form of injury or gangrene may result.

Maintenance

1. Never allow untrained personnel to service machine.
2. Implement the following work before adjusting, cleaning or repairing.
 - [1] Stop the machine on level ground.
 - [2] Disengage drive to the mechanical equipment section.
 - [3] Lower the brush section and the bucket.
 - [4] Set the parking brake.
 - [5] Stop the engine.
 - [6] Remove the ignition key.
 - [7] Wait for all movement to stop.
3. Allow the engine/muffler to cool before checking/maintenance.
4. To reduce the fire hazard, keep hot parts such as the engine and silencer/muffler, battery compartment and fuel storage area free of grass, leaves, or excessive grease.
Clean up oil or fuel spillage.
5. Appropriately manage and correctly use the tools necessary for servicing or adjusting the machine.
6. Disconnect battery before making any repairs.
Disconnect the negative terminal first and the positive last.
Reconnect positive first and negative last.
7. Use jack stands to support components when required.

Storage

16. Charge batteries in an open well ventilated area, away from spark and flames.
Unplug charger before connecting or disconnecting from battery.
Wear protective clothing and use insulated tools.
17. If the fuel tank has to be drained, do this outdoors.
1. When machine is to be parked, stored, or left unattended, keep brush section raised and securely locked while bucket lowered.
2. Allow the engine to cool before storing in any enclosure.
3. Only cover the machine with a sheet after hot parts have sufficiently cooled down.

4. Never store the equipment with fuel in the tank inside a building where fumes may reach an open flame or spark.
5. If the engine is provided with a shut-off valve, shut off valve while storing or transporting.
6. Do not store fuel near flames.

Recycle and Waste Disposal Page 2-2

About RecyclePage 2-2

About Waste Disposal Page 2-2

Disposal

Disposal

Recycle and Waste Disposal

About Recycle

Recycling battery etc. is recommended for environmental conservation and economical use of resources.

It may be required by local laws.

About Waste Disposal

Make sure that waste generated when servicing or repairing the machine is disposed of in accordance with local regulations. (e.g. waste oil, antifreeze, rubber products, and wires etc.)

Specifications Page 3-2

- SpecificationsPage 3-2
- Sound Pressure Level Page 3-3
- Sound Power Level Page 3-3
- Vibration LevelPage 3-3
- Carbon Dioxide (CO2) EmissionsPage 3-3

Names of Each Section Page 3-4

Regulation DecalsPage 3-6

- Positions of Regulation Decals Page 3-6
- Description of Regulation Decals Page 3-6

Safety Signs and Instruction Signs Page 3-9

- About Safety Signs and Instruction SignsPage 3-9
- Positions of Safety Decals and Instruction Decals Page 3-9
- Description of Safety Decals and Instruction Decals Page 3-10

Operation Decals Page 3-14

- Positions of Operation Decals Page 3-14
- Description of Operation Decals Page 3-15

Product Overview

Specifications

Specifications

Model		FS900	
Name		Riding Sweeper	
Type		Rubber tires	
Dimensions	Total length		257 cm 101.18 in
	Total width		177 cm 69.69 in
	Total height	Bucket Frame	148 cm 58.26 in
		Bottom of discharge opening (when bucket raised to the highest level)	149 cm 58.66 in
Weight	Machine (empty fuel tank) without LED light	704 kg 1552.03 lb	
Minimum turning radius		275 cm 108.27 in	
Engine	Model		Vanguard 356447
	Type		Air-cooled 4-cycle gasoline engine
	Total displacement		570 cm ³ (0.57 L) 34.78 cu.in.
	Maximum output		13.4 kW (18.2 PS)/3,600 rpm
	Rated output		-
Fuel tank capacity		Gasoline 20.0 dm ³ (20.0 L) Gasoline 5.28 U.S.gal.	
Fuel consumption		310 g/kW · h (rated output) 228 g/PS · h (rated output)	
Engine oil capacity		1.6 dm ³ (1.6 L) 0.42 U.S.gal.	
Coolant volume		-	
Hydraulic tank capacity		17.0 dm ³ (17.0 L) 4.49 U.S.gal.	
Transmission oil capacity		-	
Operating width		81 cm 31.89 in	
Operating height		-	
Bucket capacity		414 dm ³ (414 L) 109.38 U.S.gal.	
Drive	Traveling		HST (2WD)
	Sweeping section		Hydraulic, Mechanical
Speed (HST)	Forward		0 - 16.0 km/h 0 - 9.94 mph
	Reverse		0 - 5.0 km/h 0 - 3.12 mph
Speed (Mechanical)		-	
Efficiency		5,184 m ² /h (8.0 km/h x operating width x 0.8) 1.28 acres/hour (4.97 mph x operating width x 0.8)	
Maximum inclination for operation		10 degrees *5 degrees with the bucket raised	
Tire size	Front wheel		18 x 9.50 - 8
	Rear wheel		20 x 10.00 - 10
Tire pneumatic pressure	Front wheel		80 kPa (0.8 kgf/cm ²) 12 psi
	Rear wheel		150 kPa (1.5 kgf/cm ²) 22 psi
Battery		40B19L	

Engine plug	PLUG, CHAMPION XC92YC
-------------	-----------------------

* The factory default maximum engine rpm is 3,000 rpm.

Sound Pressure Level

Sound pressure level

This machine was confirmed to have a continuous A-weighted sound pressure level of 82 dB by measuring identical machines in accordance with the procedure specified in ISO5395-1:2013.

Sound Power Level

Sound Power Level

This machine was confirmed to have a sound power level of 98 dB by measuring identical machines in accordance with the procedure specified in ISO5395-1:2013.

Vibration Level

Hand-Arm Vibration

This machine was confirmed not to exceed a vibration level of 2.5 m/s^2 to hands and arms by measuring identical machines in accordance with the procedure specified in ISO 5395-1:2013.

Uncertainty K = 0.7 m/s^2

Whole Body Vibration

This machine was confirmed not to exceed a vibration level of 0.5 m/s^2 to the whole body by measuring identical machines in accordance with the procedure specified in ISO 5395-1:2013.

Uncertainty K = 0.2 m/s^2

Carbon Dioxide (CO₂) Emissions

For the CO₂ value on the engine of this machine, refer to the engine's owner's manual.

Product Overview

Names of Each Section

Overall view A

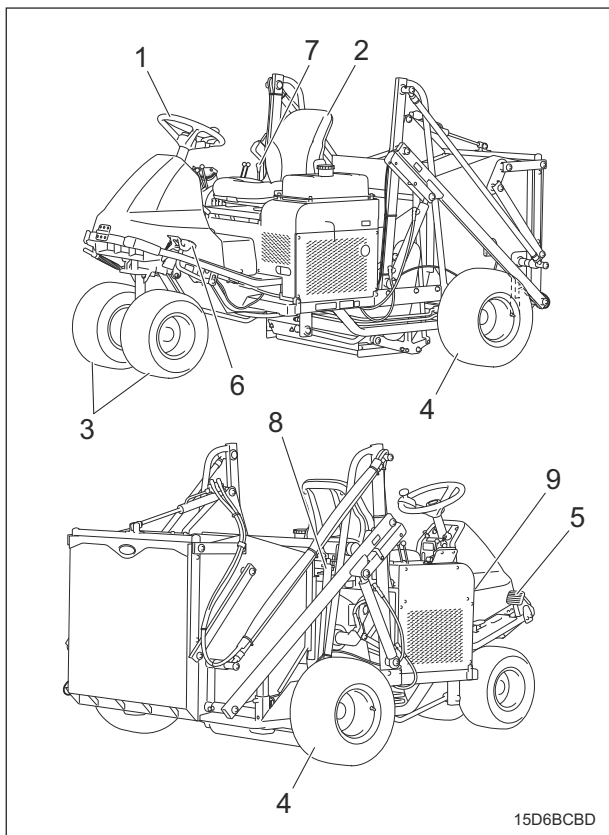

15D6BCBD

Names of Each Section_001

1	Steering wheel
2	Seat
3	Front tire
4	Rear tire
5	Traveling pedal
6	Brake pedal
7	Roller presser lever
8	Brush adjusting lever
9	Stop valve

Overall view B

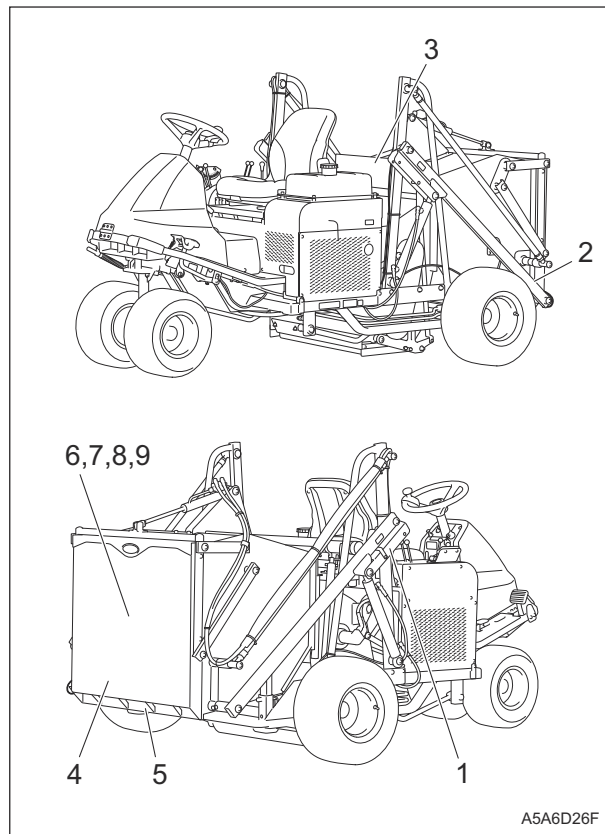

A5A6D26F

Names of Each Section_002

1	Cylinder lock
2	Outrigger
3	Brush frame
4	Bucket
5	Apron
6	Brush
7	Brush cover
8	Rotary plate
9	Roller

Product Overview

Overall view C

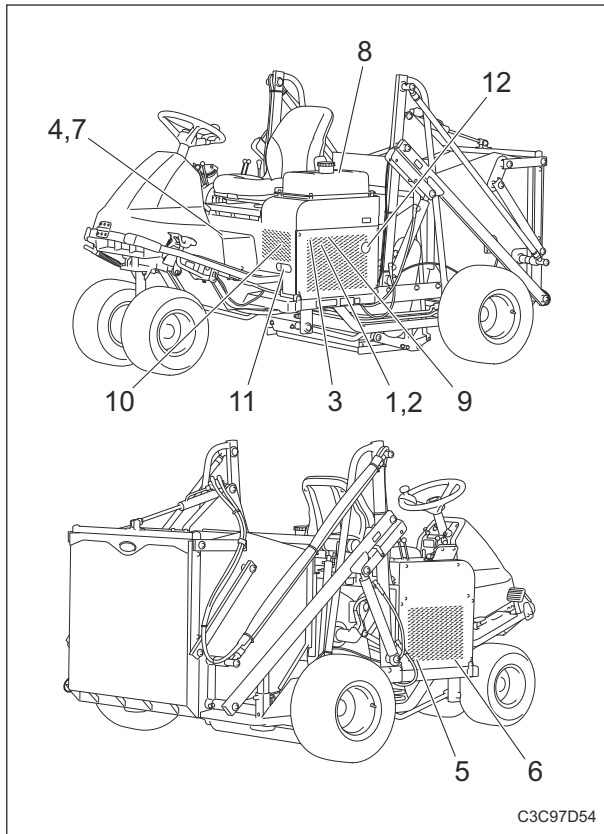

Names of Each Section_003

1	Engine
2	Engine oil filter
3	Air cleaner
4	Hydraulic tank
5	Hydraulic oil line filter
6	Hydraulic oil suction filter
7	Air breather
8	Fuel tank
9	Fuel filter
10	Fuel strainer
11	Battery
12	Muffler

Operation panel A

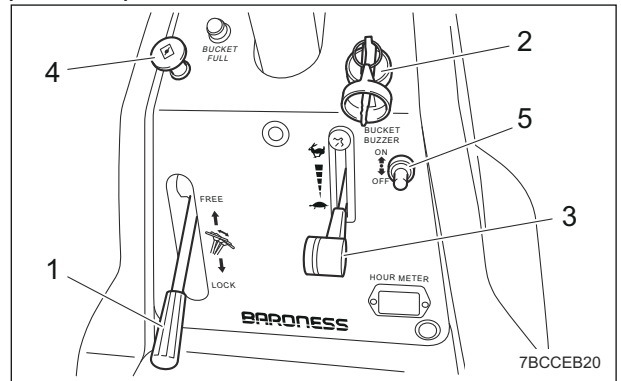

Names of Each Section_004

1	Tilt lever
2	Key switch
3	Throttle lever
4	Choke lever
5	Bucket buzzer switch

Operation panel B

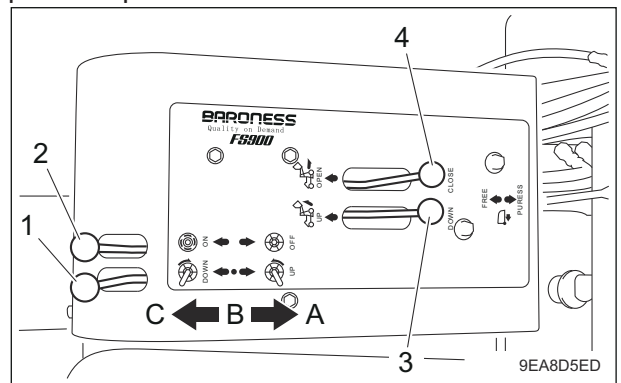

Names of Each Section_005

1	Brush up/down lever
2	Brush rotation lever
3	Bucket up/down lever
4	Bucket open/close lever

Product Overview

Product Overview

Regulation Decals

Positions of Regulation Decals

Main vehicle

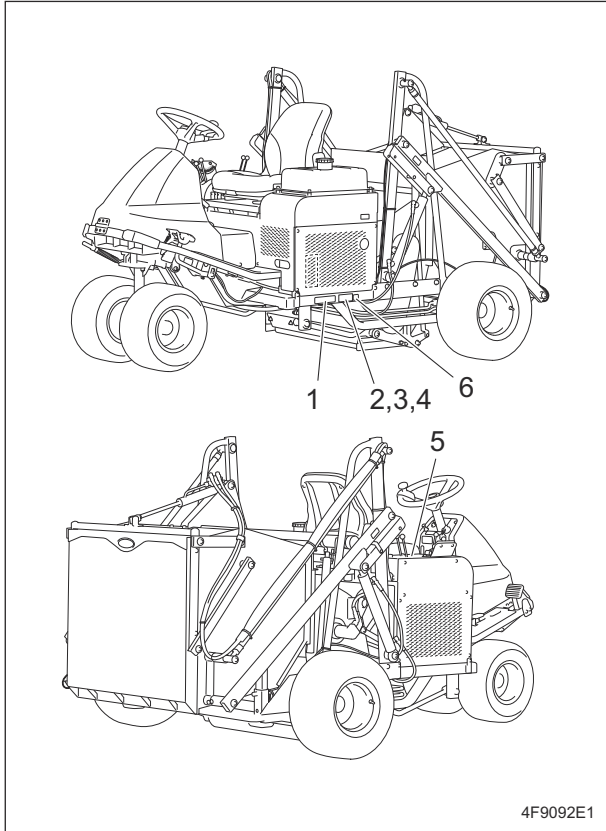

Positions of Regulation Decals_001

1	Serial number plate
2	Specification decal
3	CE mark
4	UKCA mark (#11001-11258)
5	Noise emission decal
6	Year of manufacture decal

Battery

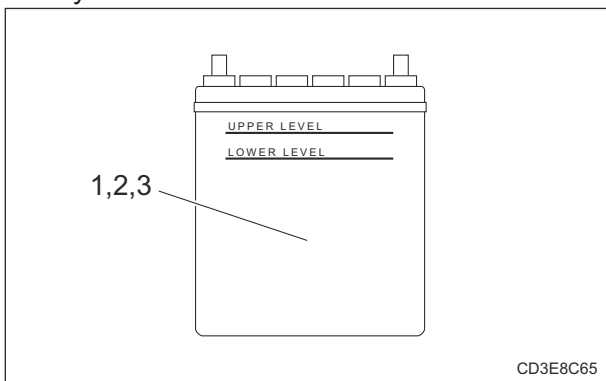

Positions of Regulation Decals_002

1	Battery capacity decal
2	EU battery regulation decal
3	Recycle decal

Description of Regulation Decals

Serial Number Plate

The serial number plate indicates the model and serial number of the machine.

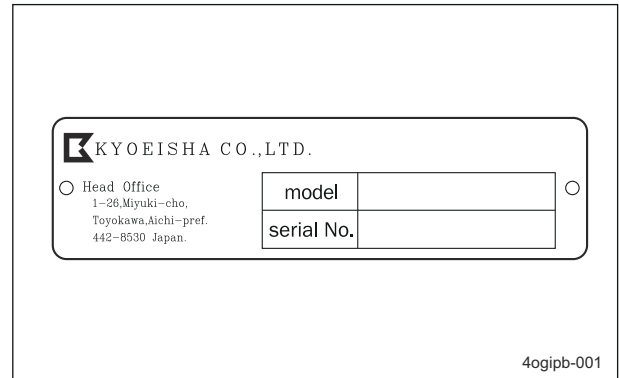

Serial Number Plate_001

Specification Decal

(For EU)

The Specification decal indicates the model and weight, etc.

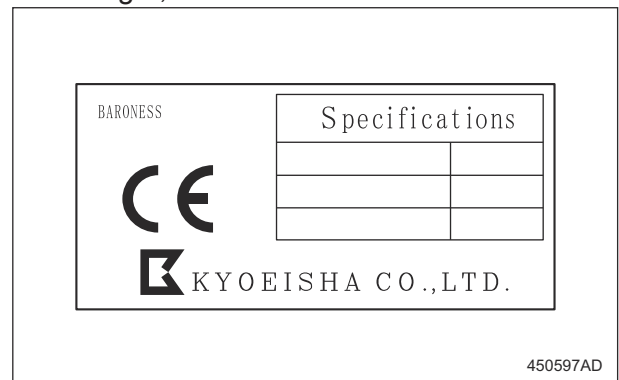

Specification Decal_001

CE Mark

(For EU)
 CE mark indicates that the machine sold in the EU nations complies with the EU requirements.

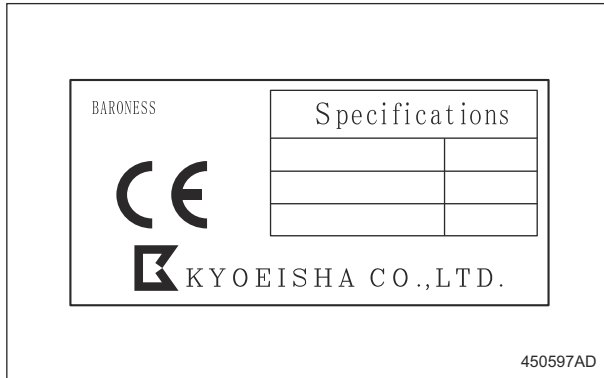

CE Mark_001

Noise Emission Decal

(For EU)
 The noise emission decal indicates the sound power level determined by measuring identical machines in accordance with the procedure specified in the regulations of EU.

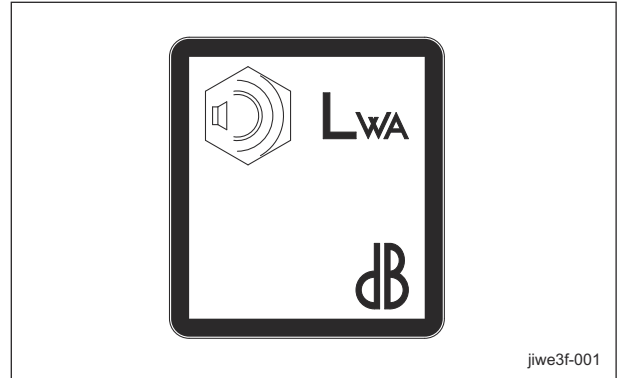

Noise Emission Decal_001

UKCA Mark

(For UK)
 UKCA mark indicates that the machine sold in the UK complies with the UK requirements.



UKCA Mark_001

Year of Manufacture Decal

(For EU)
 The year of manufacture decal indicates the year when this machine was manufactured.

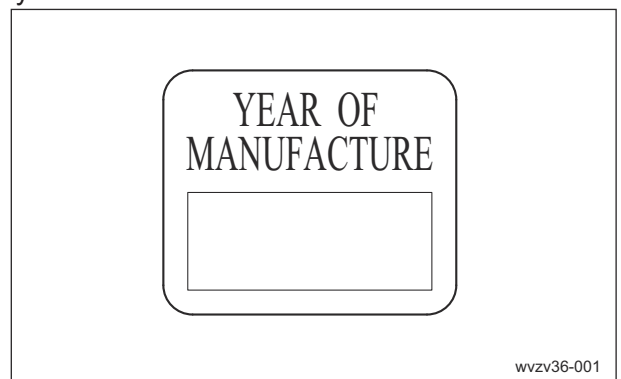

Year of Manufacture Decal_001

Product Overview

Battery Capacity Decal

(For EU)

The battery capacity decal indicates the capacity by 20HR and CCA.

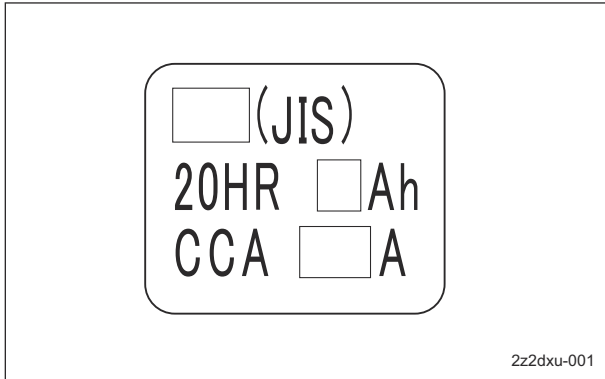

Battery Capacity Decal_001

Recycle Decal

Recycle Decal illustrates Recycle Mark in accordance with local regulation.

(For EU)

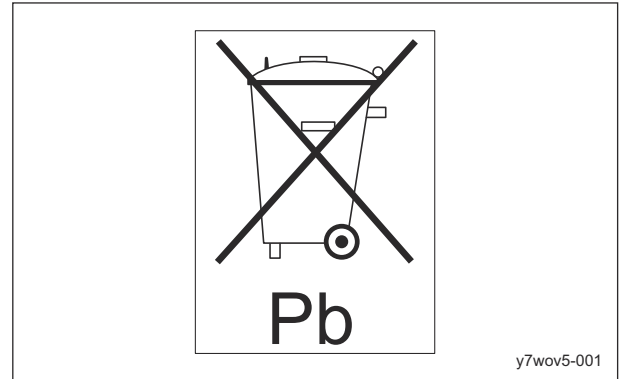

Recycle Decal_001

EU Battery Regulation Decal

(For EU)

The EU battery regulation decal indicates compliance with the EU battery regulation.

- The following information about the battery manufacturing company is written in the decal.
 - Company name
 - Address
 - Website URL
- You can scan the QR code with your smartphone to access the corresponding battery information. (*QR Code is a registered trademark of DENSO WAVE INCORPORATED.)
- CE mark indicates that the battery installed in a machine sold in the EU nations complies with the EU requirements.

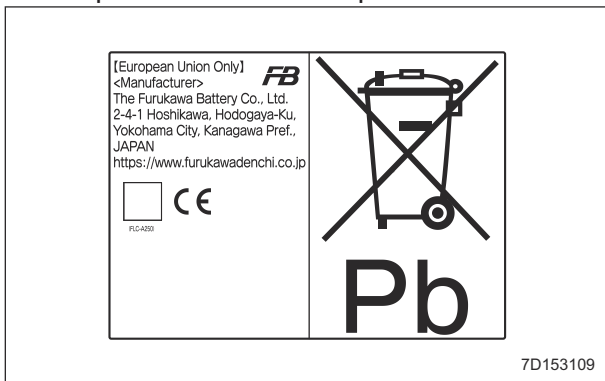

EU Battery Regulation Decal_001

(For USA)



Recycle Decal_002

Safety Signs and Instruction Signs

About Safety Signs and Instruction Signs

Important

Safety decals and instruction decals are attached to this product. Make sure that they are preserved in their entirety. If they are damaged, become dirty, or peel off, replace them with new ones.

Part numbers for decals that need to be replaced are listed in the parts catalog. Order them from a Baroness dealer or Kyoisha.

Positions of Safety Decals and Instruction Decals

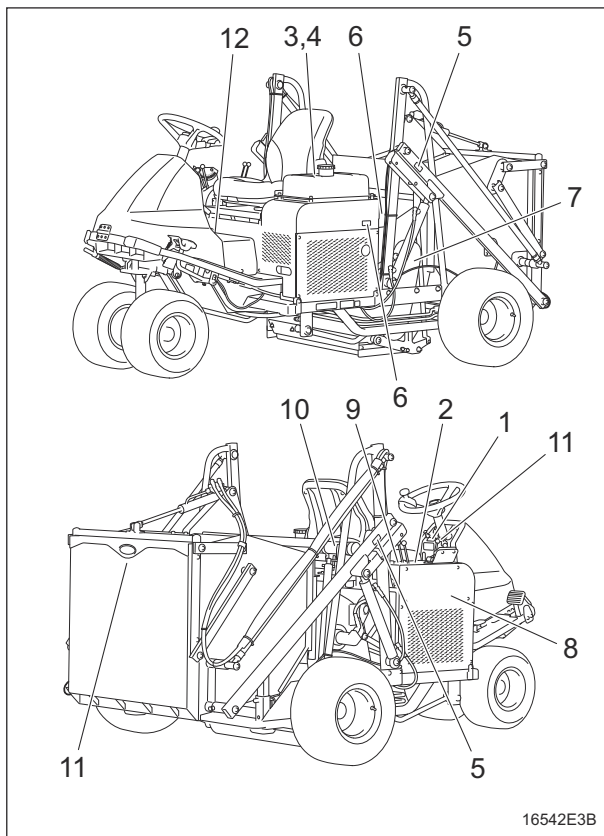

Positions of Safety Decals and Instruction Decals_001

1	Operation decal
2	Operation decal
3	Lead-free gasoline decal
4	Fire prohibited decal
5	Locking attention decal
6	Caution for high temperatures decal
7	Caution for getting entangled decal
8	Hydraulic oil decal
9	Caution to noise decal
10	Decal on reading owner's operating manual (#11001 - 11218)
11	Falling down warning decal
12	Falling down warning decal

Product Overview

Description of Safety Decals and Instruction Decals

Operation Decal

FS900--0512Z0
Decal, operation

1.



Warning

Read the Owner's Operating Manual.

2.



Warning

Apply the parking brake, stop the engine, remove the ignition key, and then leave the machine.

3.



Danger

Rollover - Do not work on slopes of 10 degrees or more.

4.



Warning

Falling down - Do not travel with the bucket raised.

5.



Warning

Do not raise or lower the bucket while obstacles, such as people or animals, are in the operating area.

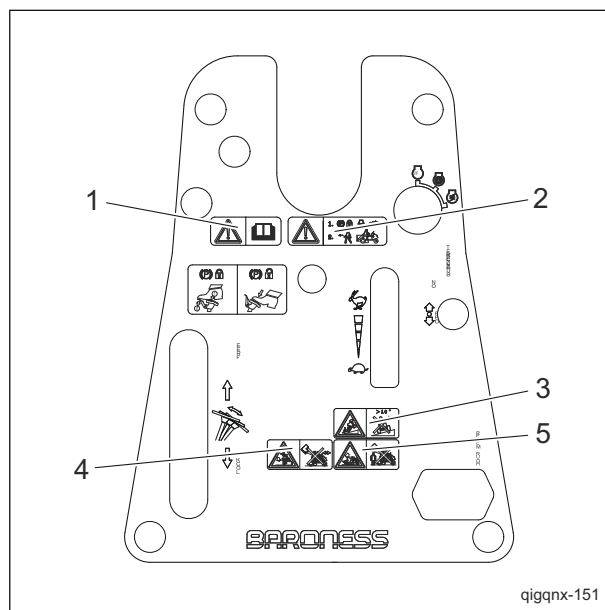

Operation Decal_001

Product Overview

Operation Decal

FS900--0514Z0
Decal, operation

1.

Caution

Caution for flying object - When the brushes are rotating, keep away from the machine.

2.

Warning

While performing inspections or maintenance, make sure that the locking mechanism is lowered onto the cylinder.

3.

Warning

Read the Owner's Operating Manual.

4.

Caution

Hands and feet getting caught - Stop the brush rotation and engine. Otherwise you may be injured.

5.

Warning

Caution for exhaust gas

6.

Caution

When the seat is raised, be sure to lock the raised seat.

7.

Warning

Falling down - Do not raise the bucket on a slope.

8.

Warning

Do not raise the bucket near obstacles, such as trees or overhead power lines.

9.

Danger

Rollover - Do not perform dumping in dangerous areas, such as near cliffs.

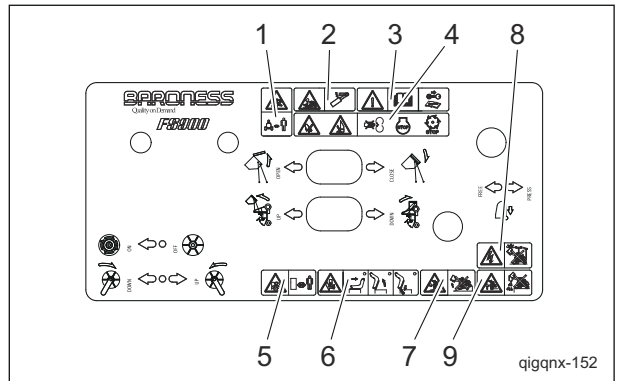

Operation Decal_001

Lead-Free Gasoline Decal

K4209001310
Decal, lead-free gasoline
Use lead-free gasoline.



Lead-Free Gasoline Decal_001

Product Overview

Fire Prohibited Decal

K4205001940
Decal, fire prohibited

Warning
Keep away from fire.



Fire Prohibited Decal_001

Caution for High Temperatures Decal

K4205001920
Decal, caution for high temperatures

Caution
High temperature - Do not touch. Otherwise, you will get burned.



Caution for High Temperatures Decal_001

Locking Attention Decal

K4205001980
Decal, caution locking

Warning
Before inspection and maintenance, be sure to apply the locking device to the cylinder.

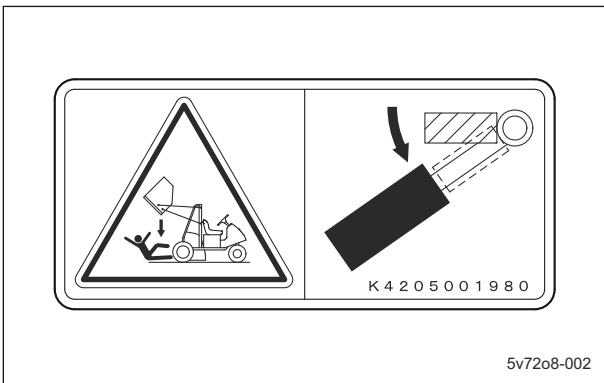

Locking Attention Decal_001

Caution for Getting Entangled Decal

K4205001910
DECAL, CAUTION NOT TO GET CAUGHT IN

Warning
Watch for rotating parts - Keep your hands away from the belts while the engine is running.

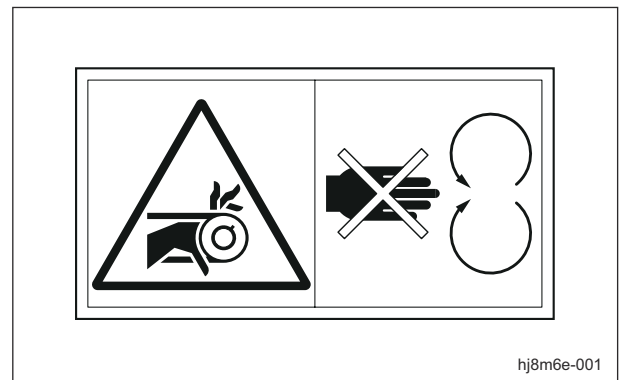

Caution for Getting Entangled Decal_001

Hydraulic Oil Decal

K4209001390
Decal, hydraulic oil
Read the owner's operating manual.

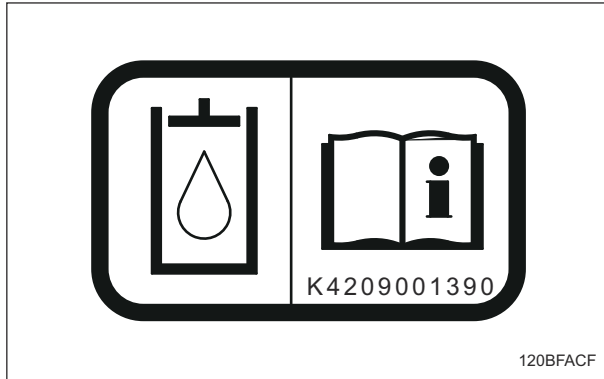

Hydraulic Oil Decal_001

Caution to Noise Decal

K4205002090
Decal, caution to noise



Caution to Noise Decal_001

Decal on Reading Owner's Operating Manual

K4205001560
Decal, read Owner's Operating Manual

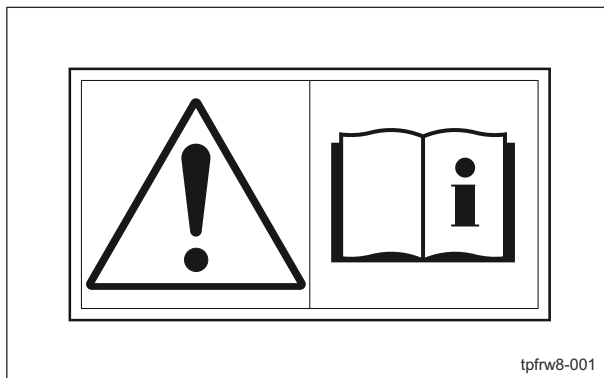
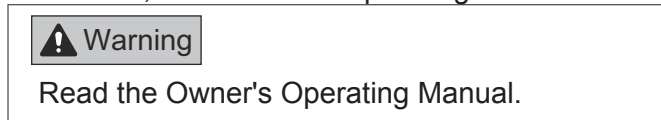

Decal on Reading Owner's Operating Manual_001

Falling Down Warning Decal

K4205002320
DECAL, WARNING FALLING DOWN

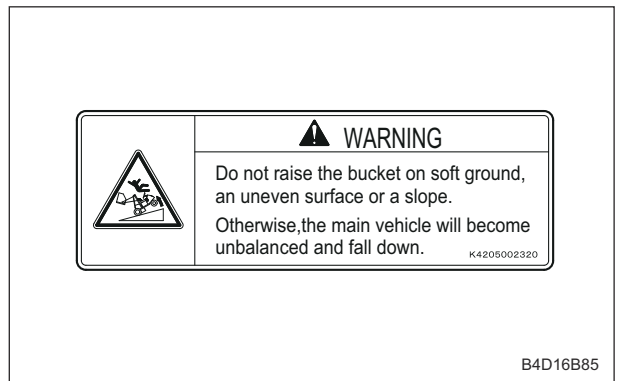
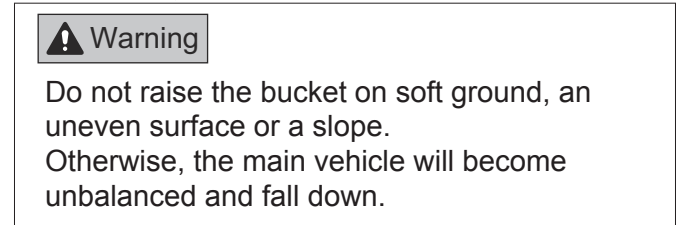

Falling Down Warning Decal_001

Falling Down Warning Decal

K4205002370
DECAL, WARNING FALLING DOWN

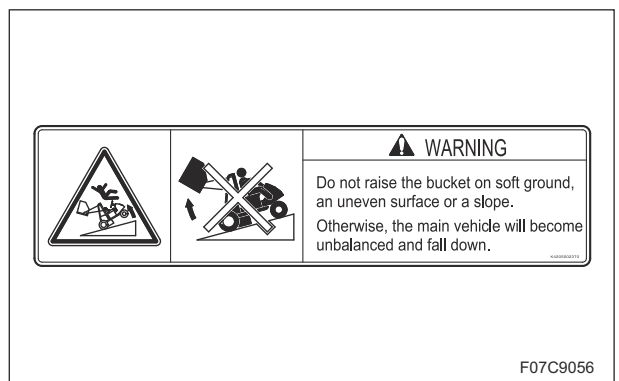
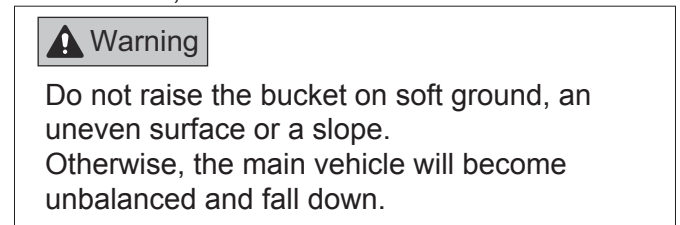

Falling Down Warning Decal_001

Product Overview

Operation Decals

Positions of Operation Decals

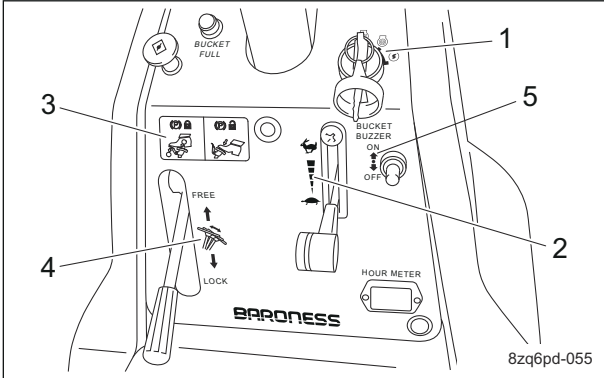

Positions of Operation Decals_001

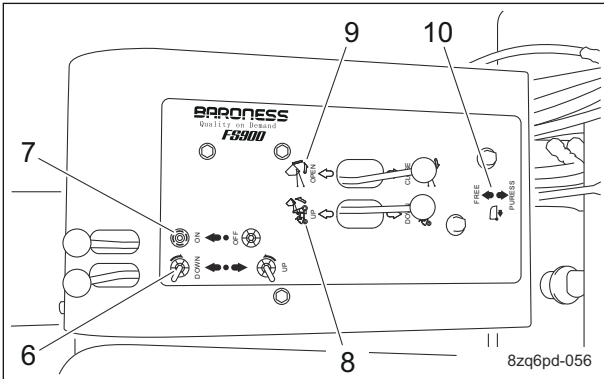

Positions of Operation Decals_002

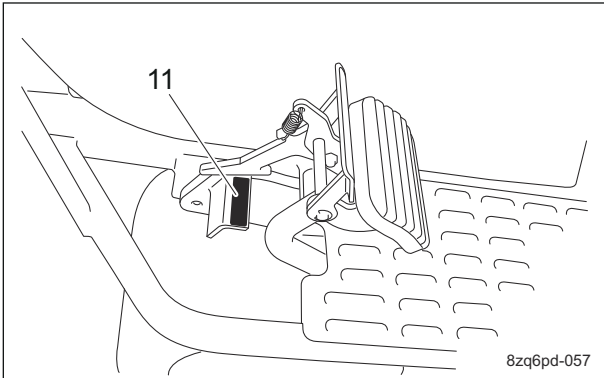

Positions of Operation Decals_003

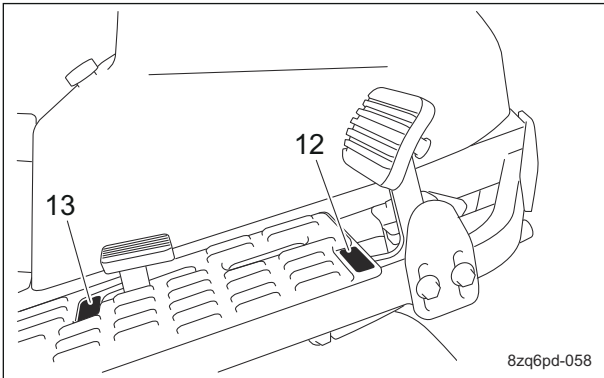

Positions of Operation Decals_004

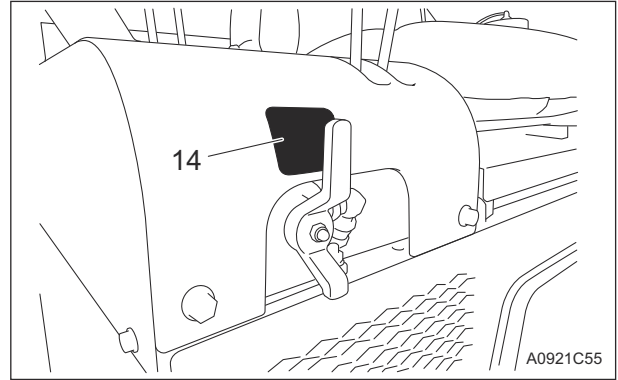

Positions of Operation Decals_005

1	Key switch mark
2	Engine rotation mark
3	Parking brake mark
4	Tilt steering mark
5	Bucket buzzer mark
6	Brush up/down mark
7	Brush rotation mark
8	Bucket up/down mark
9	Bucket open/close mark
10	Roller press mark
11	Brake decal
12	Forward decal
13	Backward decal
14	Stop valve operation decal

Description of Operation Decals

Key Switch Mark

Key switch mark
It illustrates the position of the key switch.

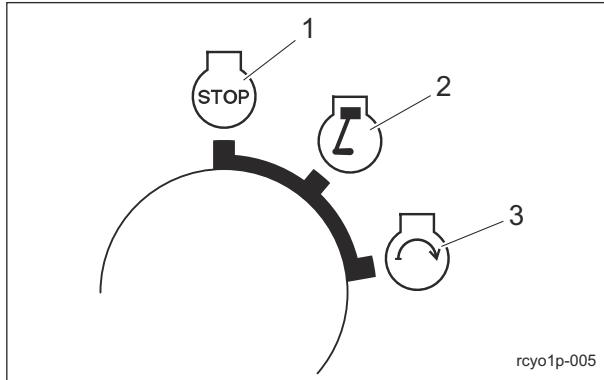

Key Switch Mark_001

1	OFF
2	ON
3	START

Engine Rotation Mark

Engine rotation mark
This indicates low/high speed of engine rotation.

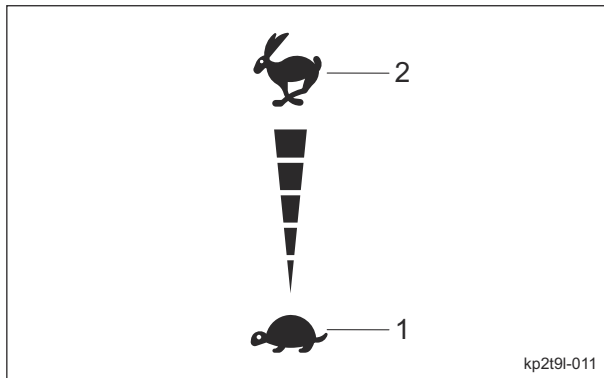

Engine Rotation Mark_001

1	Low speed
2	High speed

Parking Brake Mark

Parking brake mark
This indicates lock/release of the parking brake.

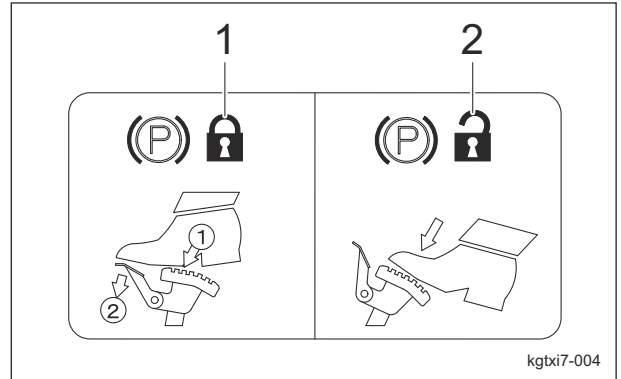

Parking Brake Mark_001

1	Lock
2	Release

Tilt Steering Mark

Tilt steering mark
This indicates the direction of tilt steering and lock/free of the position.

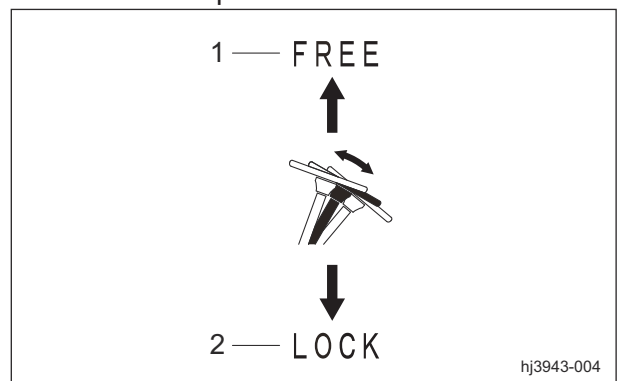

Tilt Steering Mark_001

1	FREE
2	LOCK

Product Overview

Bucket Buzzer Mark

Bucket buzzer mark
This indicates ON/OFF of bucket buzzer function.

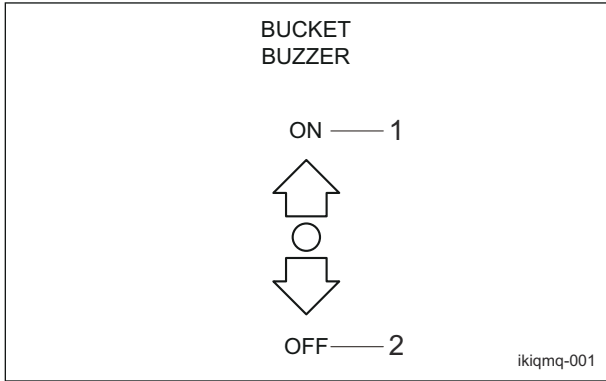

Bucket Buzzer Mark_001

1	ON
2	OFF

Brush Rotation Mark

Brush rotation mark
This indicates rotation/stop of the brush.

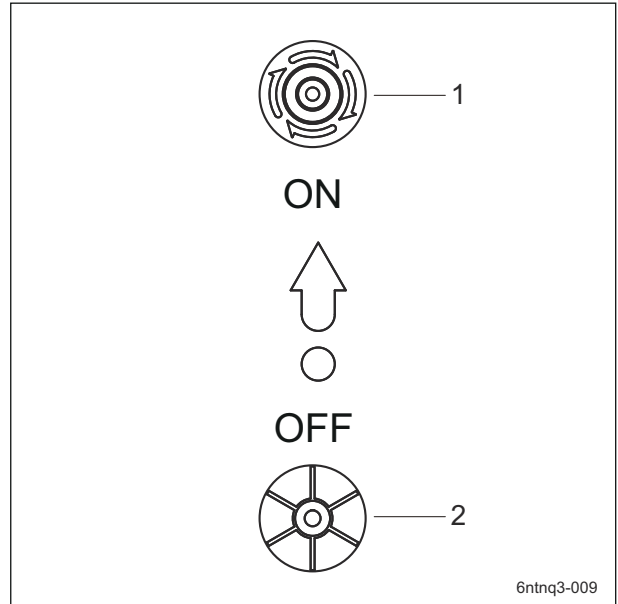

Brush Rotation Mark_001

1	Rotation
2	Stop

Brush Up/Down Mark

Brush up/down mark
This indicates Up/Down positions of the brush.

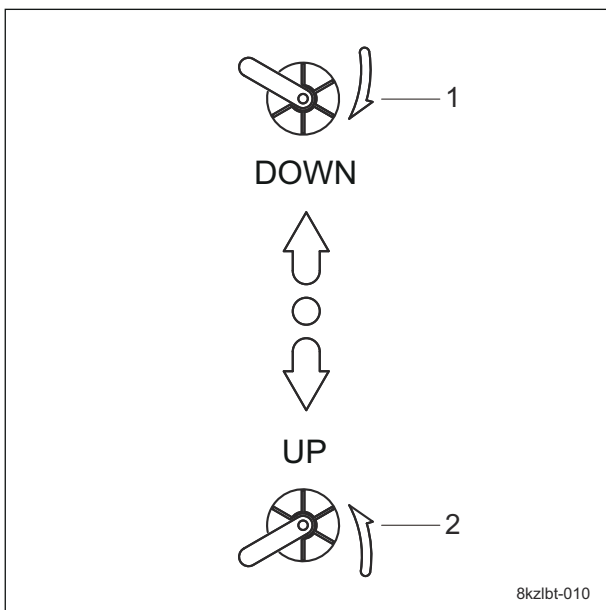

Brush Up/Down Mark_001

1	DOWN
2	UP

Bucket Up/Down Mark

Bucket up/down mark
This indicates up/down positions of the bucket.

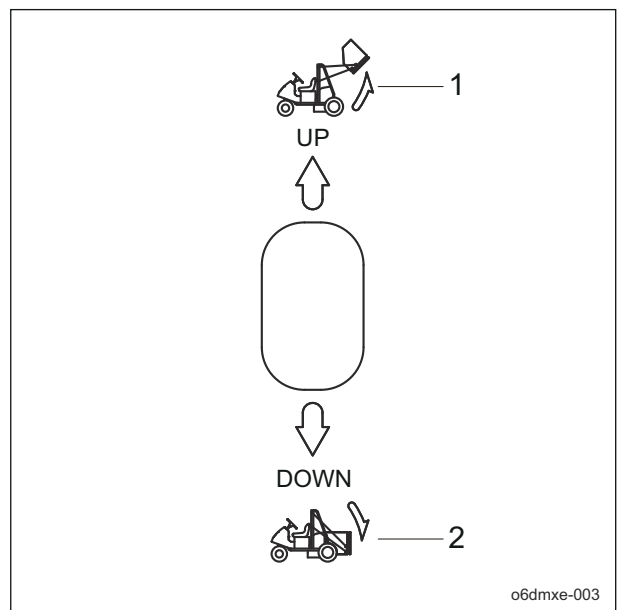

Bucket Up/Down Mark_001

1	Up
2	Down

Product Overview

Bucket Lid Open/Close Mark

Bucket lid open/close mark
This indicates open/close positions of the bucket lid.

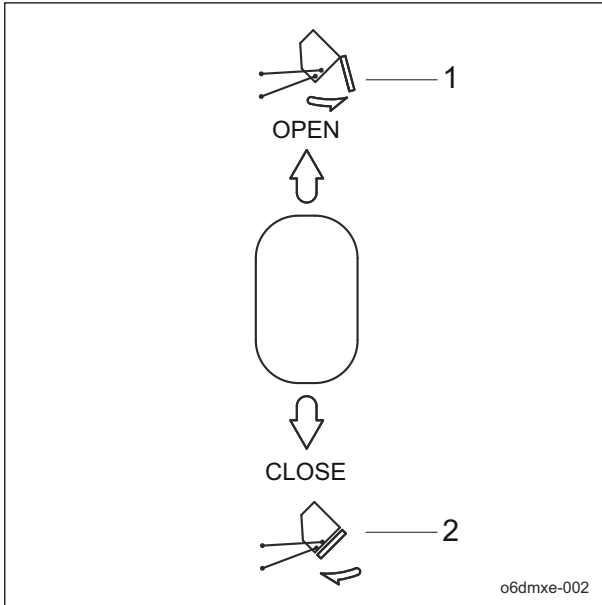

Bucket Lid Open/Close Mark_001

1	Open
2	Close

Roller Press Mark

Roller press mark
This indicates statuses of roller functions.

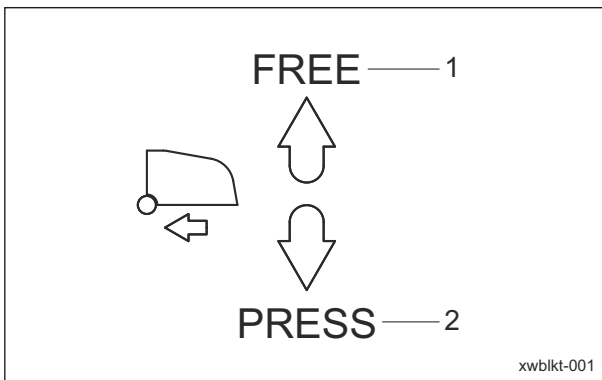

Roller Press Mark_001

1	Free
2	Press

BRAKE Decal

K4203001450
Decal, BRAKE
This indicates brake.



BRAKE Decal_001

FORWARD Decal

K4203001430
Decal, FORWARD
This indicates forward travel.



FORWARD Decal_001

BACKWARD Decal

K4203001440
Decal, BACKWARD
This indicates backward travel.

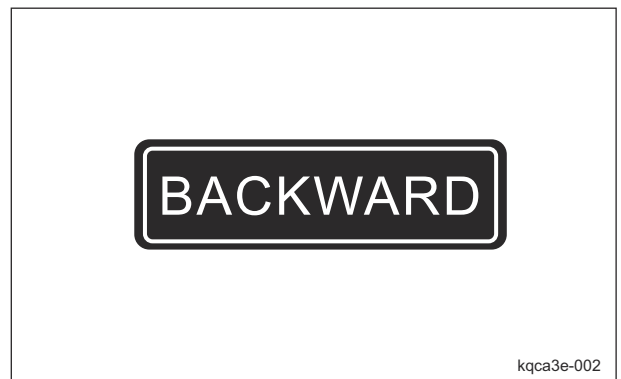

BACKWARD Decal_001

Product Overview

Stop Valve Operation Decal

K4203001290

Stop valve operation decal

It illustrates Stop/Open of the stop valve.

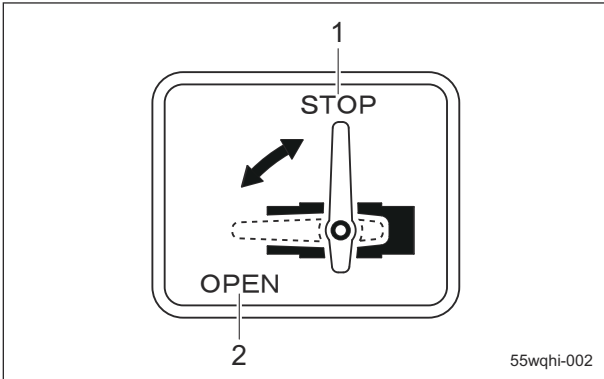

Stop Valve Operation Decal_001

1	Stop
2	Open

Description of Functions

Traveling Pedal	Page 4-2
Brake Pedal	Page 4-2
Tilt Lever	Page 4-2
Key Switch	Page 4-3
Throttle Lever	Page 4-3
Choke Lever	Page 4-3
Bucket Buzzer Switch	Page 4-3
Brush Up/Down Lever	Page 4-4
Brush Rotation Lever	Page 4-4
Stop Valve	Page 4-4
Bucket Up/Down Lever	Page 4-5
Bucket Open/Close Lever	Page 4-6
Roller Press Lever	Page 4-6
Outrigger	Page 4-7
Instruments on The Operation	
Panel	Page 4-8
Hour Meter	Page 4-8
Angle Meter	Page 4-8
Safety Device	Page 4-9
Interlock System	Page 4-9
Warning Mechanisms	Page 4-9
Bucket Buzzer	Page 4-9
Bucket FULL Lamp	Page 4-9

Description of Functions

Traveling Pedal

The traveling pedal is located in the right foot area.

When depressed "Forward", the machine travels forward. When depressed "Backward", the machine travels in reverse.

If the pedal is secured with the speed adjustment plate during operation, the machine can be operated at a constant speed.

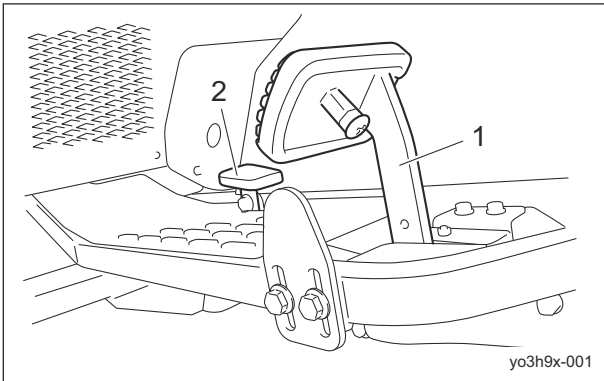

Traveling Pedal_001

1	Forward
2	Backward

Brake Pedal

Caution

Do not park the machine on a slope.

Caution

In case of the hydraulic brake malfunction, stop with the foot brake.

The brake pedal is located in the left foot area. To stop the machine, depress the brake pedal all the way firmly.

When parking, depress the locking pedal while firmly depressing the brake pedal to lock it.

To release the brake pedal, firmly depress the brake pedal to release the locking pedal.

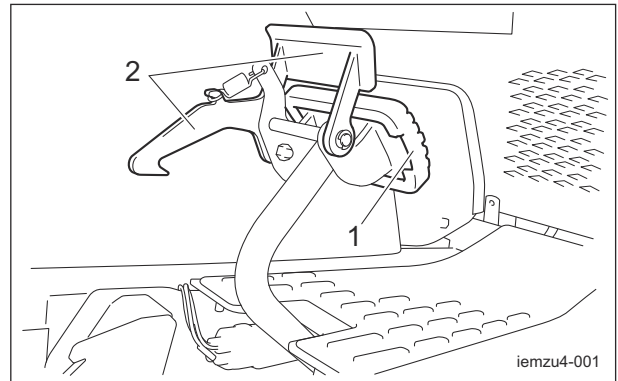

Brake Pedal_001

1	Brake pedal
2	Locking pedal

Tilt Lever

1. Shift the tilt lever to the "Release" position to release the lock and adjust the position of the steering arm.

2. Shift the tilt lever to the "Lock" position to lock the position of the steering arm.

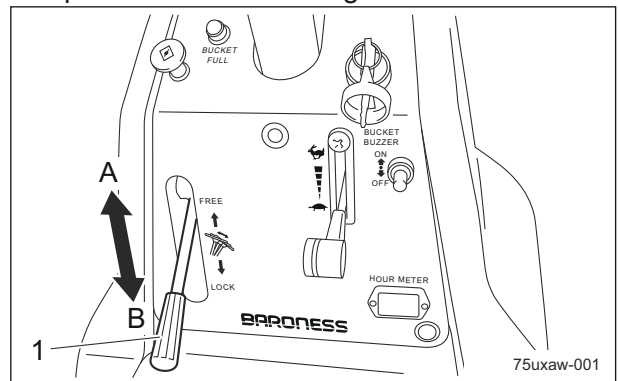

Tilt Lever_001

1	Tilt lever
A	FREE (released)
B	LOCK (locked)

Description of Functions

Key Switch

The key switch is a lock for inserting the ignition key. This is used to start, run or stop the engine by turning the ignition key to change the key switch position.

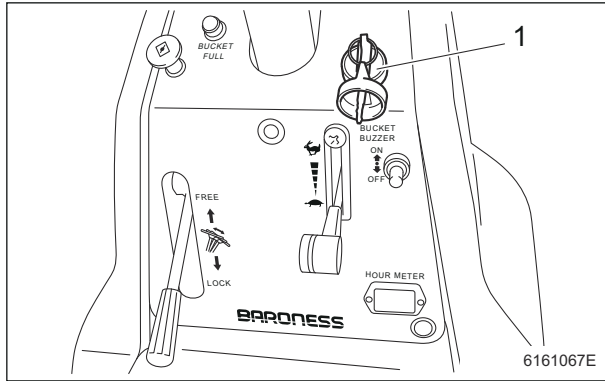

Key Switch_001

1	Key switch
---	------------

Choke Lever

The choke lever is located on the left side below the steering wheel and its knob is to be pulled when starting the engine. Pull the knob half way for restarting, as necessary.

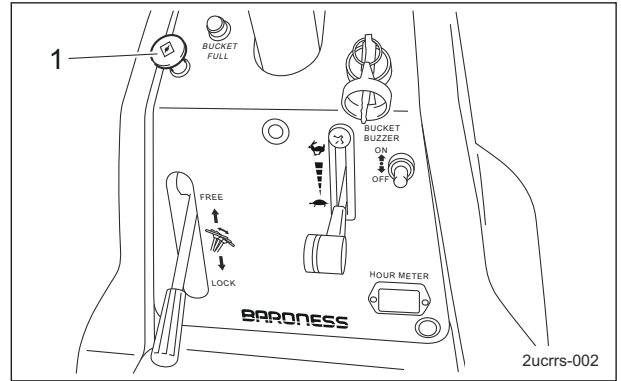

Choke Lever_001

1	Choke lever
---	-------------

Throttle Lever

The throttle lever is located below the steering wheel, on the right, and enables you to adjust the engine rpm. Move the throttle lever toward "High speed" to increase the engine rpm, and toward "Low speed" to decrease the rpm.

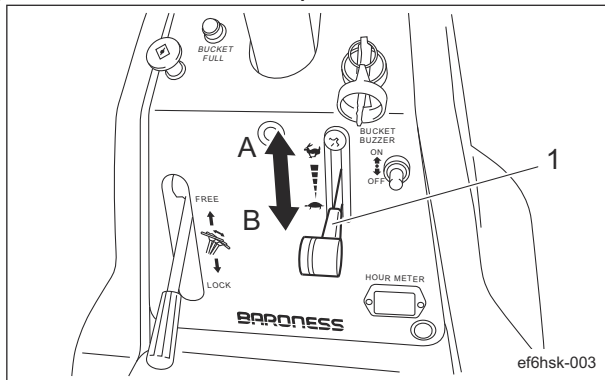

Throttle Lever_001

1	Throttle lever
A	High speed
B	Low speed

Bucket Buzzer Switch

Warning

When the bucket buzzer sounds and the bucket FULL lamp is turned on, immediately stop collecting work and discharge the collected materials in the bucket. If the collected amount in the bucket exceeds the defined amount, the machine may fall down when the bucket raised.

Always set the bucket buzzer switch to the "ON" side. When the collected amount reaches the defined amount with the bucket buzzer switch set to the "ON" position, the bucket buzzer sounds and the bucket FULL lamp is turned on. The bucket buzzer does not sound if the bucket buzzer switch set to the "OFF" side.

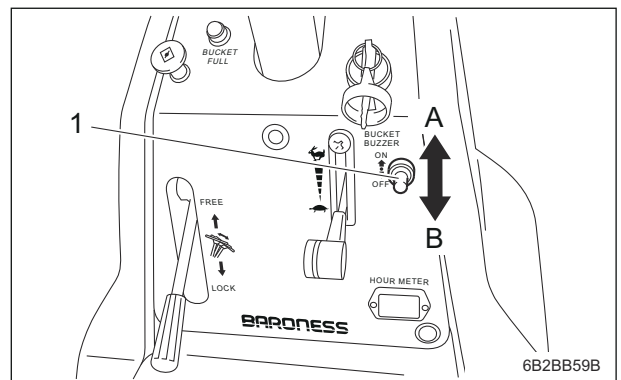

Bucket Buzzer Switch_001

Description of Functions

1	Bucket buzzer switch
A	ON
B	OFF

Brush Up/Down Lever

The brush up/down lever is located to the right of the driver's seat and is used when performing core collection and sweeping.

- When the brush up/down lever is shifted to the "UP" position, the brush frame is raised. It stops when you release the lever. However, the brush frame can not be raised while the brush is rotated.
- When the brush up/down lever is shifted to the "DOWN" position, the lever is held in place, and the brush frame is lowered into the free position.
- When the brush up/down lever is returned to the neutral position, the up/down movement of the brush frame stops.

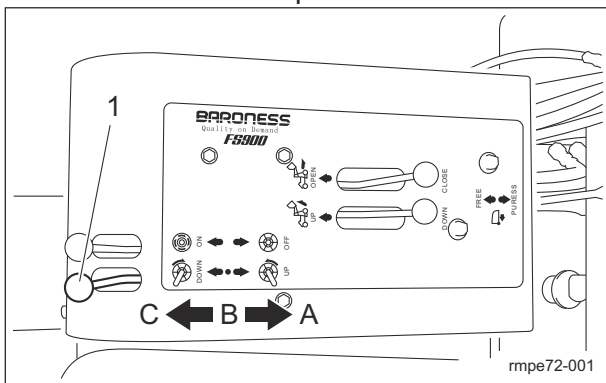

Brush Up/Down Lever_001

1	Brush up/down lever
A	Up
B	Neutral
C	Down

Brush Rotation Lever

The brush rotation lever is located to the right of the driver's seat and is used when performing core collection and sweeping.

- When the brush rotation lever is shifted to the "ON" position, the brushes and rotary plates are rotated.
- When the brush rotation lever is shifted to the "OFF" position, rotation is stopped.

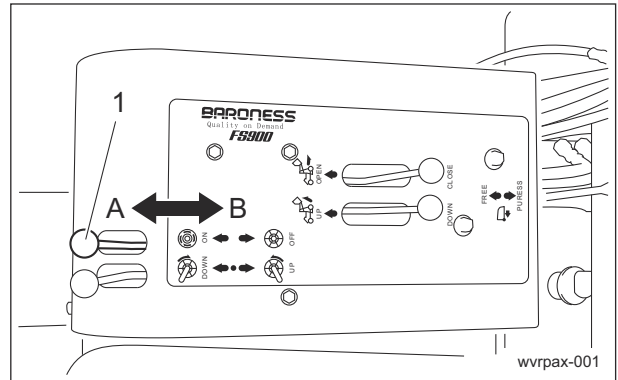

Brush Rotation Lever_001

1	Brush rotation lever
A	Rotate
B	Stop

Stop Valve

Important

When you move the machine, or if you stop the engine with the brush frame raised, be sure to set the stop valve to the "Stop" position.

The stop valve functions to prevent the raised brush frame from falling.

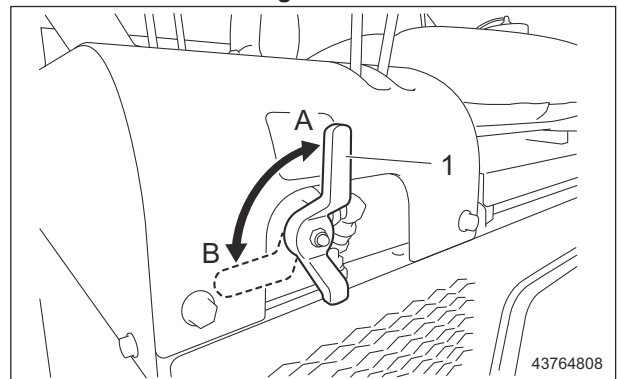

Stop Valve_001

1	Stop valve
A	Stop
B	Open

Description of Functions

Bucket Up/Down Lever

Warning

Do not raise the bucket on soft ground, an uneven surface or a slope. Otherwise, the main vehicle will become unbalanced and fall down.

Warning

Before raising the bucket, stop the machine with the front and rear wheels directed straight forward. Otherwise, the main vehicle will become unbalanced, and may fall down.

Warning

Before raising the bucket, fix the outriggers in the positions for raising the bucket. Otherwise, the main vehicle will become unbalanced, and may fall down.

Warning

Do not travel with the bucket raised. Otherwise, the main vehicle will become unbalanced and fall down.

Warning

Do not repeat shifting the bucket up/down lever abruptly. Otherwise, the main vehicle will become unbalanced, and may fall down.

Caution

Do not raise and lower the bucket while people or obstacles are nearby. Otherwise, injuries may result.

Caution

Sit on the seat when raising or lowering the bucket.

The bucket up/down lever is located to the right of the driver's seat and is used when dumping collected material into a truck, etc. When the bucket up/down lever is shifted to the "UP" position, the bucket is raised. Release the lever after the bucket rises to its highest position and stops.

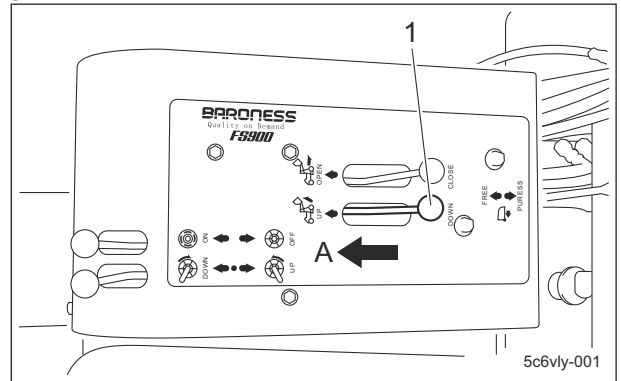

Bucket Up/Down Lever_001

1	Bucket up/down lever
A	Up

When the bucket up/down lever is shifted to the "DOWN" position, the bucket is lowered. Release the lever after the bucket lowers to its lowest position and stops.

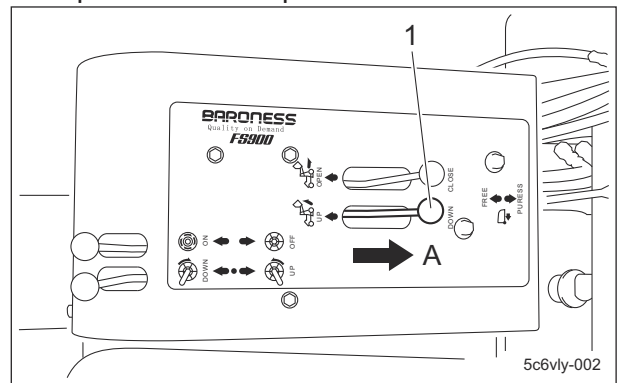

Bucket Up/Down Lever_002

1	Bucket up/down lever
A	Down

Description of Functions

Bucket Open/Close Lever

The bucket open/close lever is located to the right of the driver's seat and is used when dumping collected material from the bucket.

1. When the bucket open/close lever is shifted to the "OPEN" position, the bucket is opened. Release the lever when the bucket opens.

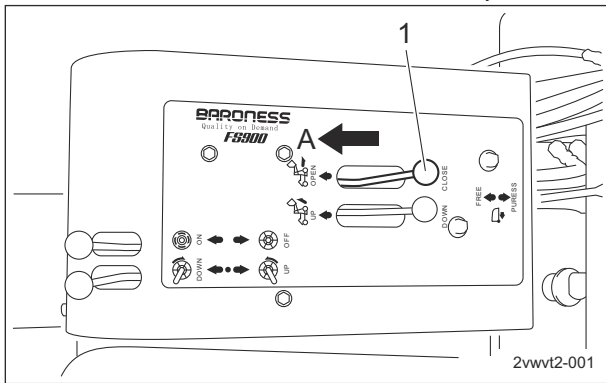

Bucket Open/Close Lever_001

1	Bucket open/close lever
A	Open

2. When the bucket open/close lever is shifted to the "CLOSE" position, the bucket is closed.

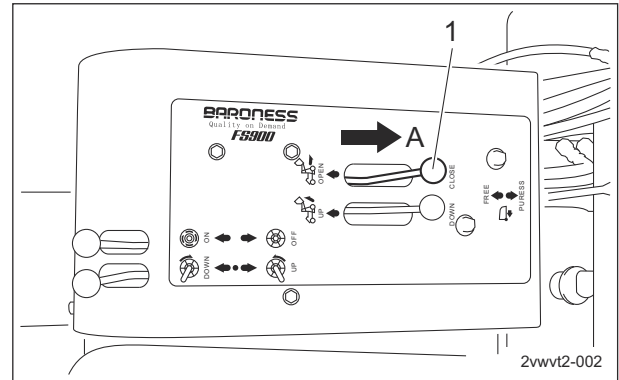

Bucket Open/Close Lever_003

1	Bucket open/close lever
A	Close

Roller Press Lever

The roller press lever is located to the right of the driver's seat and is used when performing core collection and compaction rolling.

Note:

If pressure is applied to the brush frame without the brushes being rotated, the machine can be used as a compaction roller.

- If the roller press lever is shifted to the "FREE" position, pressure is not applied to the brush frame and it is in the free position.
- If the roller press lever is shifted to the "PRESS" position, pressure is applied to the brush frame.

Important

To close the bucket lid, shift the bucket open/close lever to the "CLOSE" position and hold the lever position for 2 to 3 seconds. If the lever is released soon after shifted to the "CLOSE" position, the bucket lid will open and the collected cores, etc. will slip out.

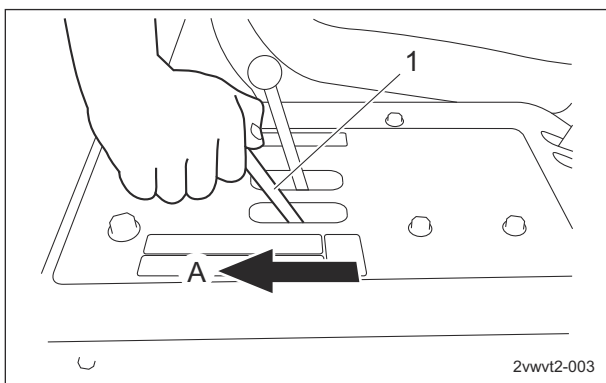

Bucket Open/Close Lever_002

1	Bucket open/close lever
A	Close

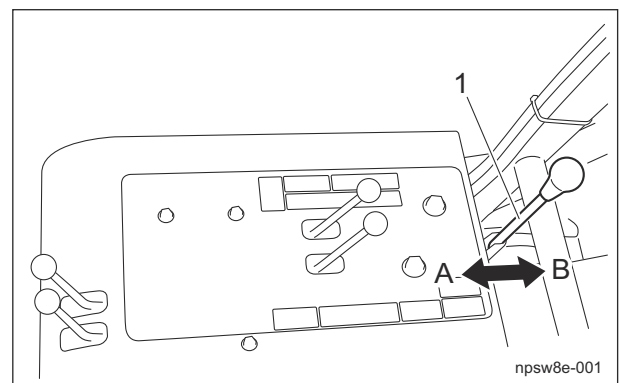

Roller Press Lever_001

1	Roller press lever
A	Free
B	Press

Description of Functions

Outrigger

The outriggers are located behind the left and right wheels and used in the following cases. When using the outriggers, apply the parking brake and choose the appropriate position of hole for the purpose.

		Hole position	
		Bumper	Outrigger
1	For traveling and collecting	High	Low
2	For raising the bucket	High	Middle
3	For storage	Low	High

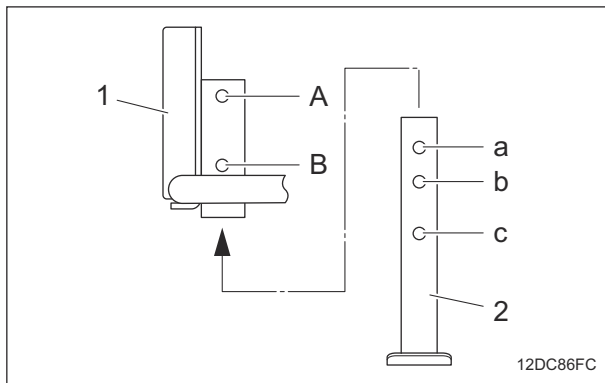

Outrigger_001

1	Bumper
2	Outrigger
A	High
B	Low
a	High
b	Middle
c	Low

1. For traveling and collecting :

- [1] Pull out the clip pin and remove the pin.
- [2] Align the holes of the outrigger and bumper on both sides.
- [3] Insert the pin and attach the clip pin.

[4] Make sure that the outriggers are fixed and not in contact with the ground.

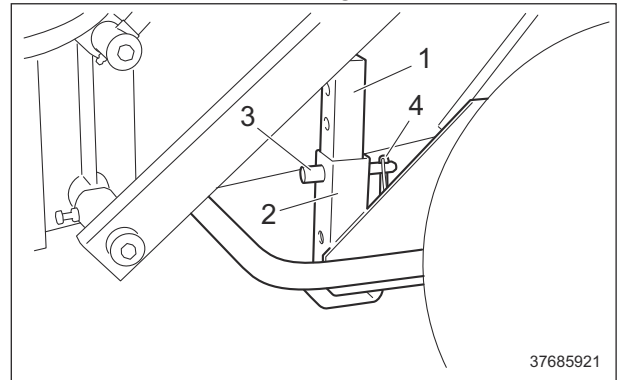

Outrigger_002

1	Outrigger
2	Bumper
3	Pin
4	Clip pin

2. For raising the bucket :

Important

Be sure to extend the outriggers on both sides.

The outriggers increase stability of the main vehicle to prevent its rollover when raising the bucket.

- [1] Pull out the clip pin and remove the pin.
- [2] Align the holes of the outrigger and bumper on both sides.
- [3] Insert the pin and attach the clip pin.
- [4] Make sure that the outriggers are fixed.

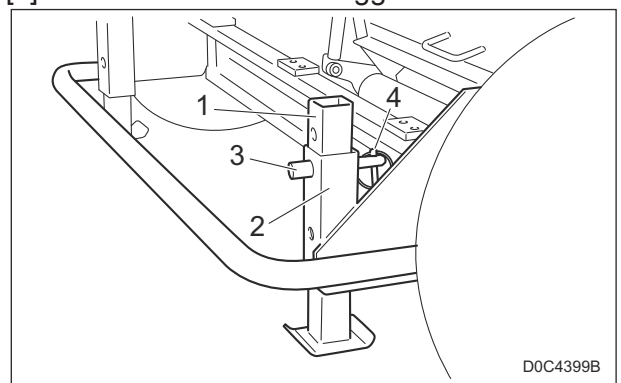

Outrigger_003

1	Outrigger
2	Bumper
3	Pin
4	Clip pin

Description of Functions

3. For storage:

Important

When urethane tires are installed, storing the machine without the tires lifted off the ground will result in the tires becoming deformed.

- [1] Place the jacks beneath the right rear frame area and the left rear frame area, and then lift the machine off the ground.
"Jack-up Points" (Page 6-2)
- [2] Pull out the clip pin and remove the pin.
- [3] Align the holes of the outrigger and bumper on both sides.
- [4] Insert the pin and attach the clip pin.
- [5] Slowly lower the jacks.
- [6] Make sure that the outriggers are fixed and that the rear tires are off the ground.

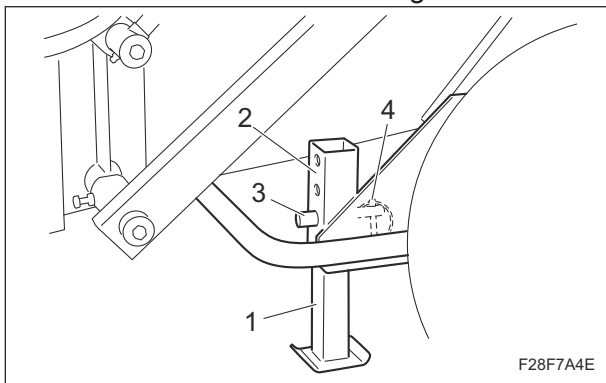

Outrigger_004

1	Outrigger
2	Bumper
3	Pin
4	Clip pin

Instruments on The Operation Panel

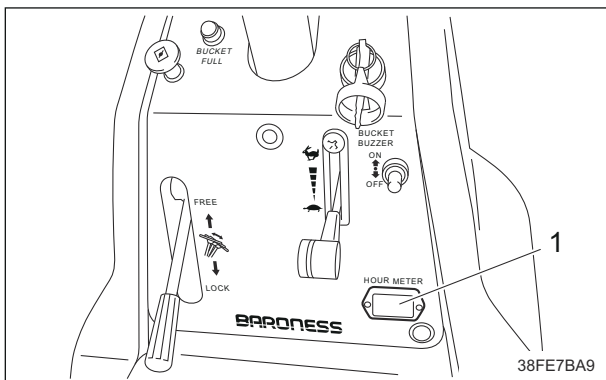

Instruments on The Operation Panel_001

1	Hour meter
---	------------

Hour Meter

The hour meter indicates the accumulated operation time of the engine.

The number in red figures on a white background is incremented every thirty-six seconds.

The number in white figures on a black background is incremented every hour.

1/100 wheel ... red figures on a white background

Hour wheel ... white figures on a black background

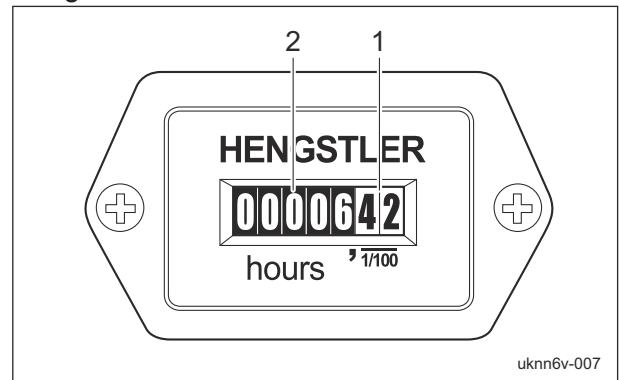

uknn6v-007

Hour Meter_001

1	1/100 wheel
2	Hour wheel

Angle Meter

The angle meter is located in the operation panel.

This instrument indicates the angle of the machine position.

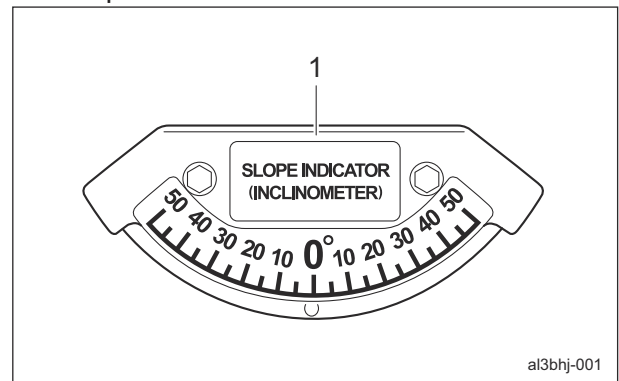

al3bhj-001

Angle Meter_001

1	Angle meter
---	-------------

Description of Functions

Safety Device

Interlock System

This machine features an interlock system for starting and stopping the engine.

1. As for starting the engine, the safety device prevents the engine from starting unless it meets each of the following three conditions.
 - An operator is sitting on the seat.
 - The parking brake is applied.
 - The traveling pedal is set to the neutral position.
2. In the event the operator leaves the seat with the parking brake not applied and the engine running, the safety device will be activated and will stop the engine.
3. In the event the operator leaves the seat with the parking brake applied and the engine running, the safety device will be activated and will stop the engine under the following condition.
 - The traveling pedal is not set to the neutral position. (The operator has depressed the traveling pedal.)

Warning Mechanisms

Bucket Buzzer

Warning

When the bucket buzzer sounds and the bucket FULL lamp is turned on, immediately stop collecting work and discharge the collected materials in the bucket.
 If the collected amount in the bucket exceeds the defined amount, the machine may fall down when the bucket raised.

Warning

Always set the bucket buzzer switch to the "ON" side.
 The bucket buzzer does not sound if the bucket buzzer switch set to the "OFF" side.

When the collected amount reaches the defined amount with the bucket buzzer switch set to the "ON" position, the buzzer sounds (intermittent sound).
 When the bucket buzzer sounds, immediately discharge the collected materials in the bucket.

Bucket FULL Lamp

Warning

When the bucket FULL lamp is turned on, immediately stop collecting work and discharge the collected materials in the bucket.
 If the collected amount in the bucket exceeds the defined amount, the machine may fall down when the bucket raised.

When the collected amount reaches the defined amount, the bucket FULL lamp is turned on.
 When the bucket FULL lamp is turned on, immediately discharge the collected materials in the bucket.

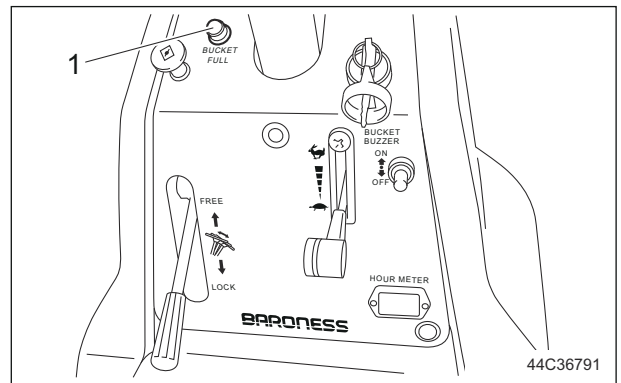

Bucket FULL Lamp_001

1	Bucket FULL lamp
---	------------------

Description of Functions

Handling Instructions

Operations before Service	Page 5-2	Storage	Page 5-18
Procedure to Open/Close Underseat Cover	Page 5-2	Short-Term Storage	Page 5-18
Procedure to Open/Close Front Cover	Page 5-2		
Procedure to Raise/Lower The Bucket	Page 5-3		
Procedure to Remove/Install The Brush Cover	Page 5-4		
Inspection before Use	Page 5-5		
Engine	Page 5-5		
Main Vehicle	Page 5-7		
Adjustment before Work	Page 5-11		
Adjustment of Seat Position	Page 5-11		
Adjustment of Steering Wheel Position	Page 5-11		
Adjustment of Brush Operation Height	Page 5-11		
Mounting and Dismounting	Page 5-12		
Procedure to Mount/Dismount	Page 5-12		
Start/Stop of Engine	Page 5-13		
Procedure to Start Engine	Page 5-13		
Procedure to Stop Engine	Page 5-13		
Parking and Stopping	Page 5-14		
Procedure to Leave The Machine	Page 5-14		
Move	Page 5-14		
Traveling Procedure	Page 5-14		
Operations	Page 5-14		
Collecting Procedure	Page 5-14		
Dumping Procedure	Page 5-16		
Transporting	Page 5-17		
Transporting Procedure	Page 5-17		
Cleaning after Use	Page 5-17		
Engine	Page 5-17		
Main Vehicle	Page 5-17		

Handling Instructions

Operations before Service

The following sections describe the preparatory works required before performing the services including inspection, adjustment, cleaning, maintenance and repair.

Procedure to Open/Close Underseat Cover

⚠ Caution

Do not open the underseat cover in strong winds.

⚠ Caution

Be careful not to pinch your fingers when you open or close the underseat cover.

1. Remove the bolt.

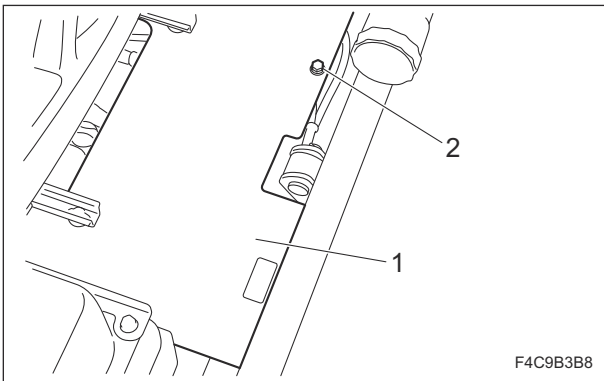

Procedure to Open/Close Underseat Cover_001

1	Underseat cover
2	Bolt

2. Raise the seat and make sure that the underseat cover stay is applied for locking. Make sure that the underseat cover remains open and then release your hand.

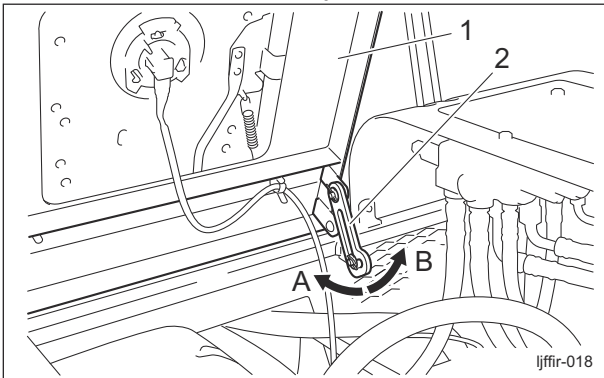

Procedure to Open/Close Underseat Cover_002

1	Underseat cover
2	Underseat cover stay
A	Lock
B	Release

3. Release locking by the underseat cover stay and then close the underseat cover slowly.

Procedure to Open/Close Front Cover

⚠ Caution

Do not open the front cover in strong winds.

⚠ Caution

When closing the front cover, be careful not to pinch your hands.

1. Remove the dimple knobs.

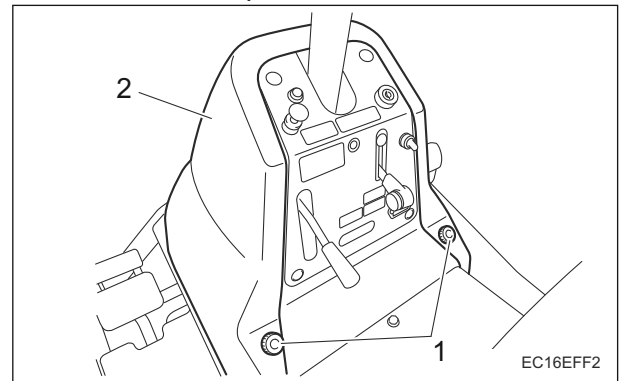

Procedure to Open/Close Front Cover_001

1	Dimple knobs
2	Front cover

2. Open the front cover, and then tilt it forward until the wire is fully extended.

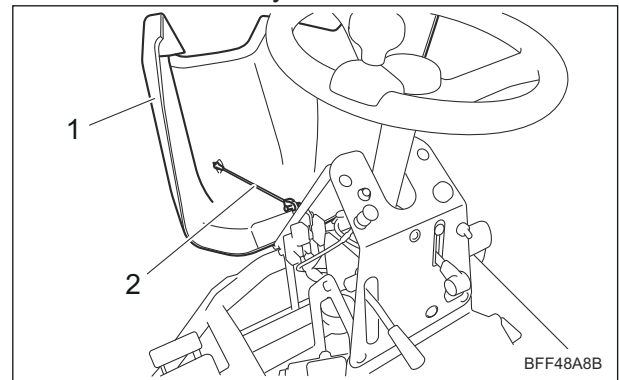

Procedure to Open/Close Front Cover_002

1	Front cover
2	Wire

3. Close the front cover slowly.
4. Install the dimple knobs.

Handling Instructions

Procedure to Raise/Lower The Bucket

Warning

Do not raise the bucket on soft ground, an uneven surface or a slope. Otherwise, the main vehicle will become unbalanced and fall down.

Warning

Before raising the bucket, stop the machine with the front and rear wheels directed straight forward. Otherwise, the main vehicle will become unbalanced, and may fall down.

Warning

Do not travel with the bucket raised. Otherwise, the main vehicle will become unbalanced and fall down.

Warning

Do not repeat shifting the bucket up/down lever abruptly. Otherwise, the main vehicle will become unbalanced, and may fall down.

Warning

Before working under the bucket, stop the engine and lock the bucket position with the cylinder lock.

Caution

Do not raise and lower the bucket while people or obstacles are nearby. Otherwise, injuries may result.

Caution

Sit on the seat when raising or lowering the bucket.

1. Procedure for raising the bucket

[1] Apply the parking brake on a level place.

[2] Stop the engine.

Important

Be sure to extend the outriggers on both sides.

The outriggers increase stability of the main vehicle to prevent its rollover when raising the bucket.

[3] Set the outriggers in the positions for raising the bucket.

[4] Start the engine.

[5] Shift the bucket up/down lever to the "UP" position to raise the bucket.

[6] Release the lever after the bucket rises to its highest position and stops.

[7] Stop the engine.

Warning

To keep the position of raised bucket, be sure to lock it with the cylinder lock.

[8] Remove the cotter pin and round head pin.

[9] Lower the cylinder lock to lock the bucket position.

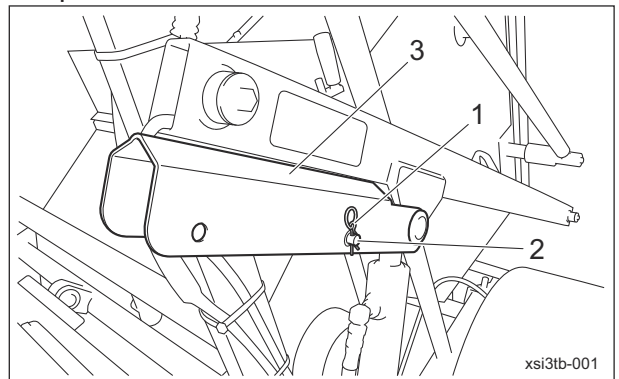

Procedure to Raise/Lower The Bucket_001

1	Cotter pin
2	Round head pin
3	Cylinder lock

Handling Instructions

- [10] Insert the round head pin through the holes in the cylinder lock, and then install the cotter pin to secure the cylinder lock.

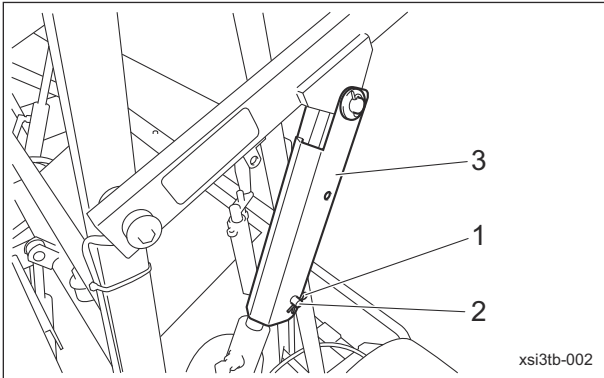

Procedure to Raise/Lower The Bucket

1	Cotter pin
2	Round head pin
3	Cylinder lock

- [11] Also on the opposite side, lower the cylinder lock and secure it.

2. Procedure for lowering the bucket

- [1] Remove the cotter pin and round head pin.
- [2] Raise the cylinder lock.
- [3] Attach the cotter pin and round head pin to secure the cylinder lock.
- [4] Also on the opposite side, raise the cylinder lock and secure it.
- [5] Make sure that the parking brake is applied.
- [6] Start the engine.
- [7] Shift the bucket up/down lever to the "DOWN" position to lower the bucket.
- [8] Release the lever after the bucket lowers to its lowest position and stops.
- [9] Stop the engine.
- [10] Return the outriggers to the position "For traveling and collecting."

Procedure to Remove/Install The Brush Cover

1. Procedure for removing the brush cover

- [1] Move the machine to level ground.
- [2] Apply the parking brake.
- [3] Raise the bucket to its highest position.

- [4] Stop the engine.

Warning

To keep the position of raised bucket, be sure to lock it with the cylinder lock.

- [5] Lock the bucket with the cylinder lock.

- [6] Disengage the left and right slide latches.

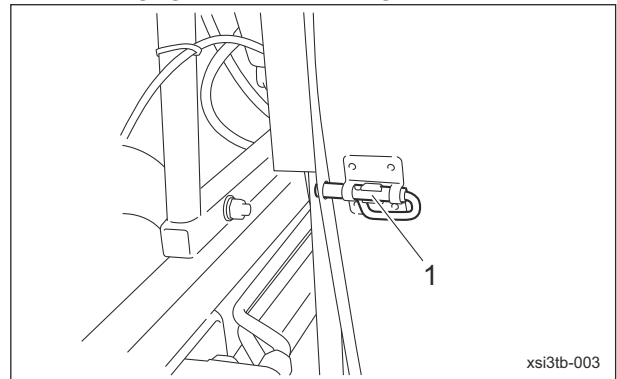

Procedure to Remove/Install The Brush Cover_001

1	Slide latch
---	-------------

- [7] Remove the brush cover.

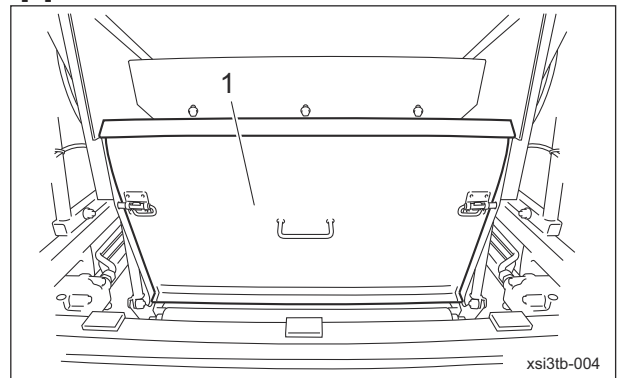

Procedure to Remove/Install The Brush Cover_002

1	Brush cover
---	-------------

2. Procedure for installing the brush cover

- [1] Install the brush cover and secure it with the left and right slide latches.
- [2] Release the cylinder lock.
- [3] Make sure that the parking brake is applied.
- [4] Start the engine.
- [5] Lower the bucket to its lowest position.
- [6] Stop the engine.

Handling Instructions

Inspection before Use

The purpose of the machine inspection is to:

- Prevent accidents
- Prevent damage to the machine
- Maintain machine performance

Detecting machine malfunctions early helps prevent unexpected problems from occurring. If you detect any abnormalities with the machine, immediately perform maintenance or repairs.

Engine

Inspection of Engine Oil

Important

Securely insert the oil level gauge.

Check the contamination of oil and engine oil level to inspect the engine oil. Inspect the engine oil level 10 to 20 minutes after stopping the engine.

1. Place the machine so that the engine is level.
2. Stop the engine.
3. Open the underseat cover.
4. Pull out the oil level gauge.

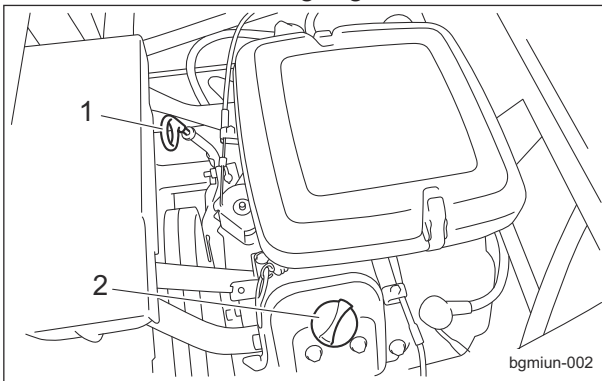

Inspection of Engine Oil_001

1	Oil level gauge
2	Oil filler cap

5. Wipe the oil off the oil level gauge cleanly with papers or cloths.
6. After wiping the oil off the oil level gauge, check the contamination.
7. Return the oil level gauge to its original position, insert tightly, and pull out again.

8. Check the engine oil level.

The appropriate oil level should be between the upper and lower limit lines on the gauge.

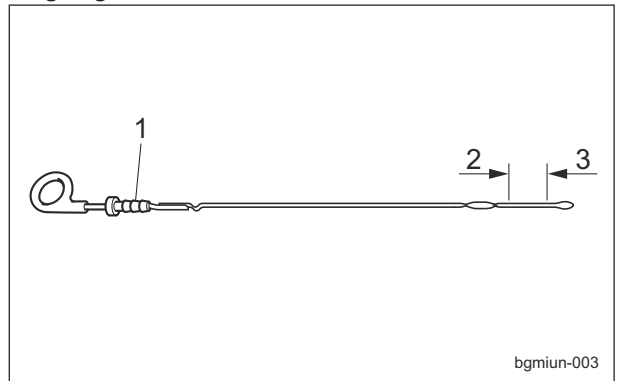

Inspection of Engine Oil_002

1	Oil level gauge
2	Upper limit
3	Lower limit

9. Return the oil level gauge to its original position, and insert it tightly.

10. Close the underseat cover.

Inspection of Fuel Quantity

With the machine on a level surface, observe the fuel gauge on the fuel tank to check the fuel level.

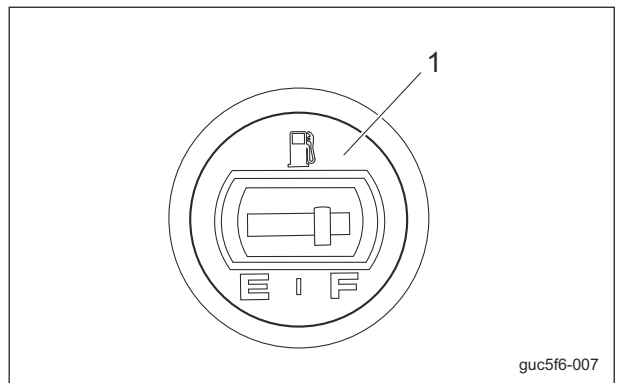

Inspection of Fuel Quantity_001

1	Fuel gauge
---	------------

Handling Instructions

Supply of Fuel

Warning

Keep fire away while refueling.
Do not smoke while refueling.

Warning

Do not supply fuel above F (FULL) level of the fuel gauge.
If you supply too much fuel, it might overflow from the tank cap when you travel or work on a slope.

If the fuel gauge located on the fuel tank indicates a level close to E (EMPTY), supply lead-free gasoline for automobiles at your earliest convenience.

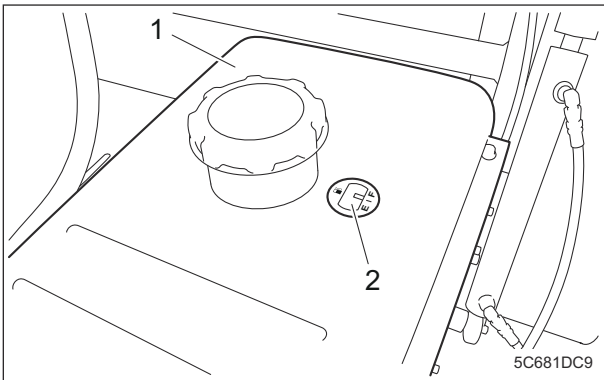

Supply of Fuel_001

1	Fuel tank
2	Fuel gauge

The fuel tank capacity up to the red ring of strainer is approximately 20.0 dm³ (20.0 L).

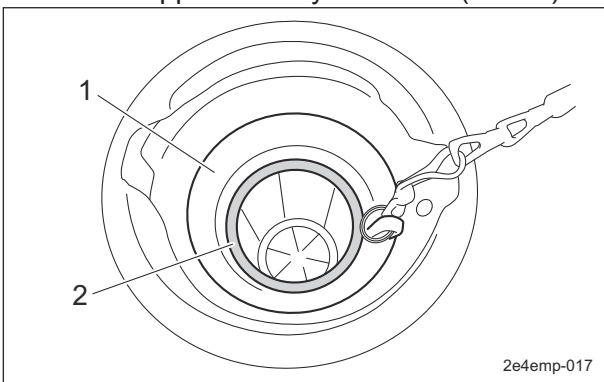

Supply of Fuel_002

1	Strainer
2	Red ring

Inspection of Air Cleaner

1. Open the underseat cover.
2. Make sure that there is no damage to the air cleaner.
3. Make sure that the air cleaner element is not contaminated.

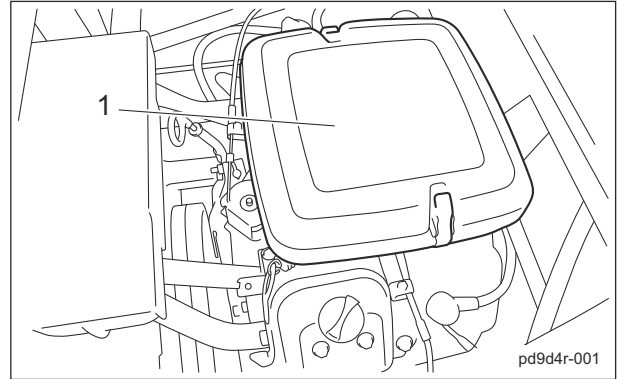

Inspection of Air Cleaner_001

1	Air cleaner
---	-------------

4. Close the underseat cover.

Inspection of Fuel Filter

1. Make sure that there is no fuel leakage.
2. Make sure that the filter is not damaged.
3. Make sure that the filter is not contaminated.

Inspection of Fuel Strainer

1. Make sure that there is no fuel leakage.
2. Make sure that the fuel strainer is not damaged or dirty.

Inspection of Engine-Associated Parts

Caution

Perform operations after the muffler, engine and other parts have sufficiently cooled. Otherwise, you may get burned.

1. Check for damages and dirt.
2. Check the mount for looseness and cracks.
3. Check for liquid leakage.
4. Check on and around the muffler for grass clippings and flammable materials.

Handling Instructions

Inspection of Bolts and Nuts

Important

The bolts and nuts may be loosened at the earlier stage of the use. Be sure to retighten or replace before operating the machine whenever there is any abnormality.

1. Check the bolts and nuts for looseness and coming off.
2. Check the bolts and nuts for cracks and damages.
3. Check the bolts and nuts for rust.
4. Check around the bolts and nuts for traces of rust fluid.
5. Check for unequal bolt length.
6. Check the bolts and nuts for stripped threads and abrasion.

Main Vehicle

Inspection of Hydraulic Oil

1. On a level surface, lower the brush frame and the bucket and maintain that position.
2. Make sure that the oil level is at the middle of the oil gauge.

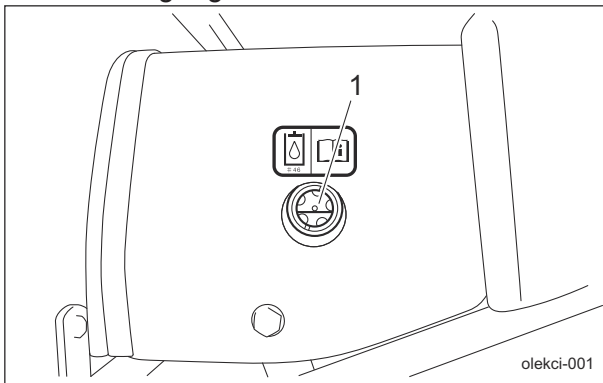

Inspection of Hydraulic Oil_001

1	Oil gauge
---	-----------

3. Check underneath the machine for oil leakage.

Inspection of Tires

1. Make sure that there are no cracks, damage or abnormal wear.
2. Check the pneumatic pressure of the tires.

Type: Rubber tires

	Tire size	Pneumatic pressure	
Front wheel	18 x 9.50 - 8	80 kPa (0.8 kgf/cm ²)	12 psi
Rear wheel	20 x 10.00 - 10	150 kPa (1.5 kgf/cm ²)	22 psi

Inspection of Battery

⚠ Danger

Keep away from fire while inspecting or charging the battery. The battery may explode.

⚠ Caution

Implement after the engine and muffler etc. have well cooled down. Otherwise, you may get burned.

Important

Be sure to stop the engine before inspecting or charging the battery.

Battery inspection items are described below.

1. Inspecting the exterior
Visually inspect the exterior of the battery, and check that there are no cracks, splits, missing sections, or abnormal deformation in the battery case, and that there is no electrolyte leaking. If abnormalities are found, immediately replace the battery.
2. Cleaning the exterior

⚠ Warning

Do not clean the battery with a dry cloth. Cleaning the battery with a dry cloth may cause it to catch fire or explode due to static electricity.

Use a wet cloth for cleaning. Inspect the vent plugs or vent holes on the side of the battery, and if they are blocked by dirt wash them with water to remove the blockage. Continuing to use the battery with the vent holes blocked may cause the battery to rupture from increased internal pressure due to gases generated inside the battery.

Handling Instructions

3. Inspecting the mounting bracket

Inspect whether the battery is secured firmly with the mounting bracket. If the bracket is loose, tighten the mounting bracket nuts until the battery is secured firmly.

An improperly mounted battery may cause damage to the battery case or electrolyte leaks due to the battery moving with vibrations while traveling.

4. Inspecting the cable terminals

If the connection between the battery terminals and vehicle's cable terminals are loose, tighten the nuts until the cable terminals are secured firmly.

Insufficiently tightened terminals may result in poor battery charging, damage to the terminals due to poor contacts, or an explosion.

If the terminals are corroded, rub them clean with a wire brush or fine grit sandpaper, and lightly apply anti-rust grease.

5. Inspecting the electrolyte level and refilling

Warning

Do not allow the battery fluid level to become lower than the LOWER LEVEL (minimum fluid level line).

The battery may explode if it is used or charged while the battery fluid level is at the LOWER LEVEL (minimum fluid level line).

Warning

When refilling, do not fill purified water above the UPPER LEVEL line.

Doing so may result in electrolyte leaks.

Clean the areas around the battery fluid level lines using a cloth damped with water to check the electrolyte level from the side of the battery.

Make sure that the battery fluid level is between the UPPER LEVEL (maximum fluid level line) and the LOWER LEVEL (minimum fluid level line).

Refill with purified water up to the UPPER LEVEL line if the level is lower than halfway between the UPPER LEVEL and LOWER LEVEL lines.

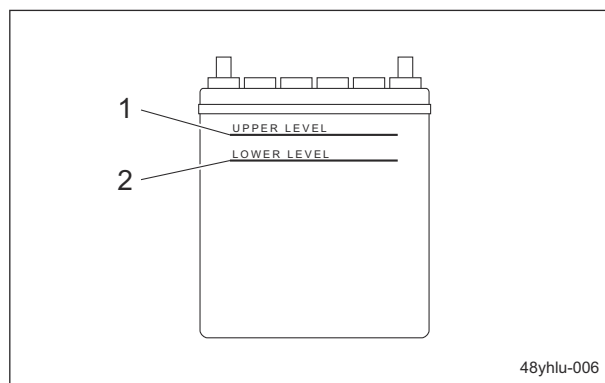

Inspection of Battery_001

1	UPPER LEVEL line
2	LOWER LEVEL line

Inspection of Outrigger

1. Make sure that there is no bend or deformation.
2. Make sure that there is not damage or deterioration.
3. Make sure that the pin is not missing.

Inspection of Covers

Warning

If you have removed a protective cover during inspection, be sure to securely install it in its original position.

If a protective cover remains removed, foreign objects may fly off, and the operator or the mechanic can be injured.

1. Make sure that there is no wear or deterioration of protective covers.
2. Make sure that there is no damage to protective covers.
3. Make sure that there is no interference with moving parts due to deformation of protective covers.
4. Make sure that protective covers are installed in their appropriate positions.

Inspection of Brake Pedal

1. Make sure that there is no play in the pedal.
2. Make sure that the pedal moves smoothly.
3. Make sure that there is no abnormal sound when the pedal is depressed.
4. Make sure that the pedal does not touch the floorboard when the pedal is depressed.

Handling Instructions

Inspection of Parking Brake

1. Depress the locking pedal while firmly depressing the brake pedal to lock it and check that the brake is applied effectively.
2. Firmly depress the brake pedal and release the locking pedal to release the brake pedal, and then check that the brake is not applied.

Inspection of Traveling Pedal

1. Make sure that there is no play in the pedal.
2. Make sure that the pedal moves smoothly.
3. Make sure that there is no abnormal sound when the pedal is depressed.

Inspection of Wire

1. Make sure that the wire is not cracked or damaged.
2. Make sure that the wire is not worn.
3. Make sure that the wire is not crushed.
4. Make sure that the wire is not bent.
5. Make sure that the wire is not corroded or rusted.

Inspection of Liquid Leakage

Important

After approximately 50 hours of operation, some tightened portions may be loosened and liquid such as oil may leak. Be sure to retighten the parts.

Important

Repair the machine before operation if liquid leakage found. Ignoring leakage will cause further trouble.

1. Check the bottom of the machine for leakage of liquid such as oil, water, fuel, etc.
2. Locate the leakage and identify the type of liquid.

Inspection of Bolts and Nuts

Important

The bolts and nuts may be loosened at the earlier stage of the use. Be sure to retighten or replace before operating the machine whenever there is any abnormality.

1. Check the bolts and nuts for looseness and coming off.
2. Check the bolts and nuts for cracks and damages.
3. Check the bolts and nuts for rust.
4. Check around the bolts and nuts for traces of rust fluid.
5. Check for unequal bolt length.
6. Check the bolts and nuts for stripped threads and abrasion.

Inspection of Hour Meter

1. Check the hour meter is not damaged.
2. Check the hour meter operates correctly.
 - [1] Switch the ignition key to the "ON" position.
 - [2] Check the displayed number increases correctly.
 - [3] Switch the ignition key to the "OFF" position.

Inspection of Angle Meter

1. Check the angle meter is not damaged.
2. Check the angle meter operates correctly.

Inspection of Safety Device

Repair the machine before operation whenever there is any abnormality.

1. Interlock system
Make sure that the interlock system operates correctly.
"Interlock System" (Page 4-9)
2. ROPS
(If the machine is equipped with ROPS and a seat belt)
Make sure that the ROPS is not damaged or broken.

Handling Instructions

3. Seat belt

(If the machine is equipped with ROPS and a seat belt)

Make sure that the seat belt is not damaged or broken.

Inspection of Steering Wheel

1. Make sure that there is no play in the steering wheel.
2. Make sure that the steering wheel turns smoothly when it is turned.
3. Make sure that there is no abnormal sound when the steering wheel is turned.
4. Check the direction of tires when the steering wheel is turned.

[1] Start the engine.

[2] Make sure that the front tire turns right when the steering wheel is turned right.

[3] Make sure that the front tire turns left when the steering wheel is turned left.

[4] Stop the engine.

Inspection of Light

Note:

Depending on the specifications, this function may not be available.

1. Check the lights are not damaged.
2. Check the lights turn on/off.
 - [1] Switch the ignition key to the "ON" position.
 - [2] Set the light switch to the "ON" position.
 - [3] Check the lights have turned on.
 - [4] Set the light switch to the "OFF" position.
 - [5] Check the lights have turned off.
 - [6] Switch the ignition key to the "OFF" position.

Inspection of Bucket

1. Make sure that there is no foreign matter or damage on the bucket.
2. Make sure that the rubber frame is not peeling off.

Inspection of Bucket Lid

1. Make sure that the lid closes securely.
2. Make sure that there is not foreign matter or damages on the bucket lid.

Inspection of Brush

Warning

Be sure to fix the bucket by using the bucket anti-drop bar to retain the posture with the bucket raised.

Caution

Wear a helmet during an inspection.

1. Make sure that there is no bent or wear in the brush.
2. Make sure that there is no wear in the brush shaft.
3. Make sure that there is no play in the brush shaft.

Inspection of Rotary Plate

Warning

Be sure to fix the bucket by using the bucket anti-drop bar to retain the posture with the bucket raised.

Caution

Wear a helmet during an inspection.

1. Make sure that there is no bent or wear in the rotary plate.
2. Make sure that there is no wear in the rotary shaft.
3. Make sure that there is no play in the rotary shaft.

Inspection of Apron

1. Make sure that there is no wear in the apron.
2. Make sure that there is no damage or deformation in the apron.

Inspection of Rollers

1. Make sure that there is no abrasion nor adhesion of the roller.
2. Make sure that there is no wear of the roller shaft.
3. Make sure that there is no wear nor damage of the oil seal.
4. Make sure that there is no wear nor rust of the bearing.

Handling Instructions

5. Make sure that there is no play in the roller shaft.

Adjustment before Work

Adjustment of Seat Position

Warning

Since it is dangerous, do not adjust while traveling.

Use the adjustment lever to adjust the seat position back and forth. Adjust the position according to the operator's body size. The adjustment lever is located on the left front part of the seat.

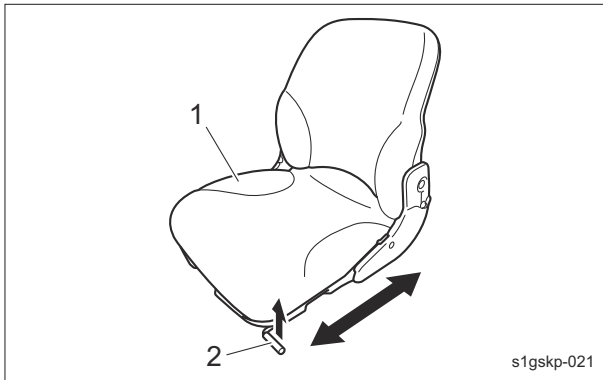

Adjustment of Seat Position_001

1	Seat
2	Adjustment lever

Adjustment of Steering Wheel Position

Warning

Since it is dangerous, do not adjust while traveling.

Caution

Be sure to lock securely. Looseness during traveling may cause an accident.

Use the tilt lever to adjust the steering wheel position up or down to fit the operator's body size.

1. Shift the tilt lever to the "FREE" position.
2. Adjust the steering wheel position.

3. Shift the tilt lever to the "LOCK" position to secure the steering wheel position.

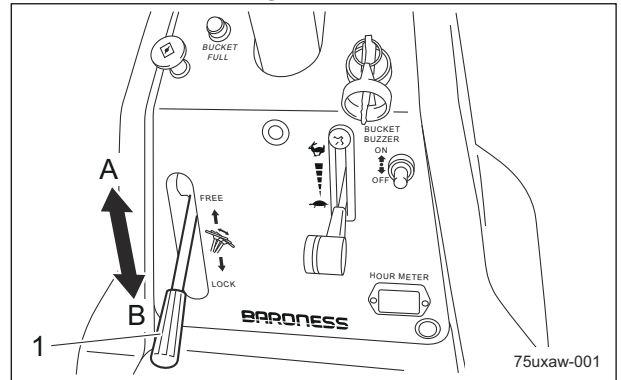

Adjustment of Steering Wheel Position_001

1	Tilt lever
A	FREE (released)
B	LOCK (locked)

Adjustment of Brush Operation Height

Warning

Be sure to stop the engine before adjusting the height of the brushes.

Important

If the brush operation height is inadequate, cores will not be properly collected.

Important

If the left and right sides of the brushes are at different heights, the cores will not be uniformly collected, and the brushes will wear unevenly.

Important

Adjust the height of the brushes according to the core size and quantity.

1. Move the machine to level ground, and then apply the parking brake.
2. Stop the engine.

Handling Instructions

3. Shift the brush up/down lever to the "DOWN" position to lower the brush frame.

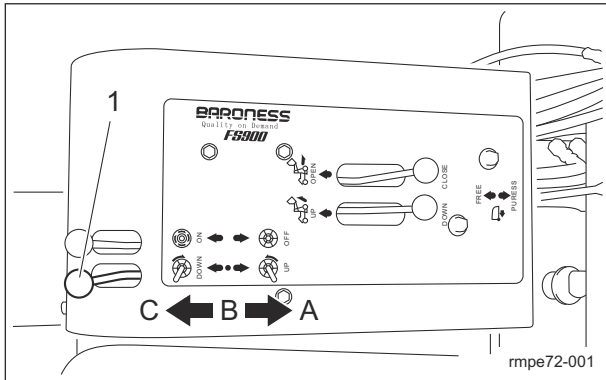

Adjustment of Brush Operation Height_001

1	Brush up/down lever
A	Up
B	Neutral
C	Down

4. Manually rotate the brushes until a brush is at its lowest point.

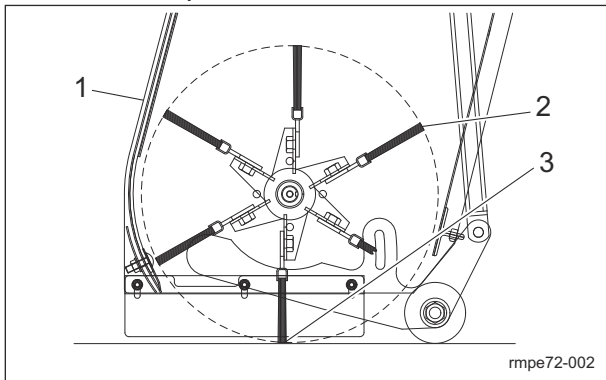

Adjustment of Brush Operation Height_002

1	Brush frame
2	Brush
3	Lowest point

5. Remove the retaining pin and locking pin.

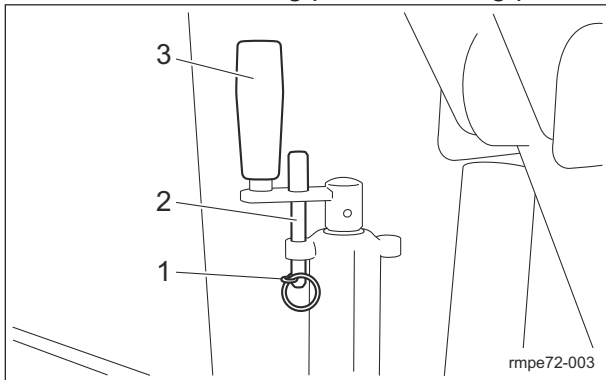

Adjustment of Brush Operation Height_003

1	Retaining pin
2	Locking pin
3	Brush adjusting handle

Important

Adjust the brush so that the left and right sides are even.

6. Turn the brush adjusting handle to raise the brush to approximately 6 mm (0.24 in) [cutting height+3 mm (0.12 in)]. Turning the handle to the right (clockwise) lowers the brush. Turning the handle to the left (counterclockwise) raises the brush.

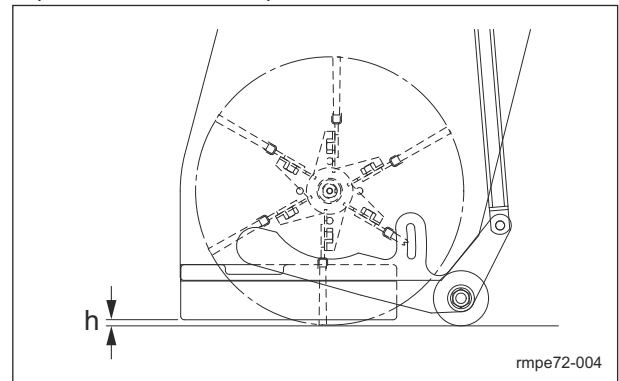

Adjustment of Brush Operation Height_004

h	Brush height
---	--------------

7. Re-place the locking pin and retaining pin.
 8. Perform actual work, and gradually adjust the brushes to the appropriate collection position. Check with an adjustment at every half turn.

Mounting and Dismounting

Procedure to Mount/Dismount

Caution

Make sure that there are no obstacles or people around the machine.

Mount and dismount from the left side of the machine.

Handling Instructions

Start/Stop of Engine

Procedure to Start Engine

Caution

Do not start the engine in a building with insufficient ventilation.

Caution

Before starting the engine, make sure that there are no other people or obstacles around the machine.

Caution

Make sure that the covers are correctly in place and are not damaged.

Important

Starter operation must take 15 seconds or less. If the engine does not start, stop using the battery for 30 to 60 seconds to avoid exhausting the battery.

1. Open the fuel cock.
This locates near the fuel tank.

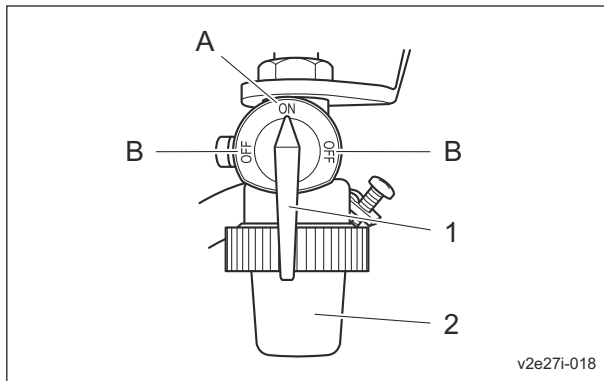

Procedure to Start Engine_001

1	Fuel cock
2	Fuel filter
A	ON (OPEN)
B	OFF (CLOSE)

2. Sit on the seat.
3. Make sure that the parking brake is applied.
4. Make sure that the traveling pedal is in neutral position.
5. Move the throttle lever to the middle position between "High" and "Low".

6. Pull the choke knob.
Pull the choke knob half way for restarting, as necessary.
7. Switch the ignition key to the "START" position.

Important

Quickly returning the ignition key from the "START" position to the "ON" position may result in damage to the machine.

8. When the starter starts rotating and the engine starts, slowly return the ignition key to the "ON" position.
9. Check that the engine has started, and then return the choke knob to its original position.
10. Shift the throttle lever to "Low", and then warm up the engine.
Approximate warming-up time
 - 3 to 5 minutes when the outside temperature is less than 20 degrees Celsius (68 °F)
 - 2 to 3 minutes when the outside temperature is 20 degrees Celsius (68 °F) and over

Procedure to Stop Engine

1. Lower the bucket to its lowest position.
2. Raise the brush frame.
3. Set the stop valve to the "STOP" position.
4. Set the traveling pedal in neutral position.
5. Apply the parking brake.
6. Move the throttle lever to "Low", and continue idling for 1-2 minutes.
7. Switch the ignition key to the "OFF" position.
8. Make sure that the engine has stopped.

Handling Instructions

Parking and Stopping

Procedure to Leave The Machine

Caution

If the brakes are not sufficiently effective, use the wheel stoppers to secure the machine.

Caution

Never park the machine on a slope.

1. Park the machine on level ground.
2. Apply the parking brake.
3. Stop the engine.
4. Remove the ignition key.
5. Step off the machine.
6. Close the fuel cock.

Move

Traveling Procedure

Warning

Do not travel with the bucket raised.

Caution

Under any circumstances drive the machine at such a speed that you can stop it immediately for emergencies.

Important

Do NOT start to move or stop the machine abruptly. It will damage the hydraulic system or result in oil leakage.

1. Start the engine.
2. Make sure that the brush frame is raised.
3. Make sure that the stop valve is set to the "STOP" position.
4. Gradually move the throttle lever toward the "High speed" position.
5. Release the parking brake.
6. Slowly depress the traveling pedal.
7. The machine starts traveling.
8. The machine stops slowly when the foot leaves the traveling pedal.

Operations

Collecting Procedure

Danger

Do not perform collecting operation on a slope with an angle of gradient that is greater than 10 degrees.

Caution

Make sure that the bucket lid is closed.

Caution

Collection work must be performed at an appropriate speed for the site and location. When collecting over bumpy surfaces, keep the engine rpm steady, and slow down the speed.

Caution

Before beginning collection work, be sure to perform a safety check of the intended work area.

Important

Do NOT start to move or stop the machine abruptly. It will damage the hydraulic system or result in oil leakage.

1. Start the engine.
2. Set the stop valve to the "OPEN" position.
3. Make sure that the brush frame is raised.
4. Shift the throttle lever to the "High speed" position, and rev up the engine to MAX.
5. Release the parking brake.

 **Warning**

Always set the bucket buzzer switch to the "ON" side.

The bucket buzzer does not sound if the bucket buzzer switch set to the "OFF" side.

6. Make sure that the bucket buzzer switch is set to the "ON" side.

Important

When working on a lawn, rotating the brushes with the brush frame lowered while the machine is stopped may damage the lawn since it continues to be hit by the brushes.

7. Shift the brush rotation lever to the "ON" position to rotate the brushes.
8. Depress the traveling pedal to start traveling.
9. At the area where the operation is started, shift the brush up/down lever to the "DOWN" position.

Note:

During collection work, the lever is held in the "DOWN" position, and the brush frame is in the free position.

 **Warning**

When the bucket buzzer sounds and the bucket FULL lamp is turned on, immediately stop collecting work and discharge the collected materials in the bucket.

If the collected amount in the bucket exceeds the defined amount, the machine may fall down when the bucket raised.

10. At the area where the operation is finished, shift the brush rotation lever to the "OFF" position to stop the brushes.
11. Shift the brush up/down lever to the "UP" position.
12. Repeat steps 6. to 10. to perform the collection work.
13. After finishing the collection work, shift the brush rotation lever to the "OFF" position to stop the brushes.

Handling Instructions

Dumping Procedure

Danger

Do not perform dumping operation on slopes of 5 degrees or more.

Danger

Do not perform dumping operation in dangerous areas, such as near cliffs.

Warning

Do not raise the bucket on soft ground, an uneven surface or a slope. Otherwise, the main vehicle will become unbalanced and fall down.

Warning

Before raising the bucket, stop the machine with the front and rear wheels directed straight forward. Otherwise, the main vehicle will become unbalanced, and may fall down.

Warning

Before raising the bucket, fix the outriggers in the positions for raising the bucket. Otherwise, the main vehicle will become unbalanced, and may fall down.

Warning

Do not travel with the bucket raised. Otherwise, the main vehicle will become unbalanced and fall down.

Warning

Do not repeat shifting the bucket up/down lever abruptly. Otherwise, the main vehicle will become unbalanced, and may fall down.

Warning

Before working under the bucket, stop the engine and lock the bucket position with the cylinder lock.

Caution

Do not raise and lower the bucket and do not open and close the bucket lid while people or obstacles are nearby. Otherwise, injuries may result.

1. Move the vehicle to a dumping area, and then back up to the dumping spot and park at a position to raise the bucket.
2. Apply the parking brake.
3. Fix the outriggers in the positions for raising the bucket.
4. Raise the bucket to its highest position.
5. Release the parking brake.
6. Slowly back up to a position where the collected trash cannot slip out.
7. Apply the parking brake.
8. Shift the bucket open/close lever to the "OPEN" position to open the bucket. Release the lever when the bucket opens.
9. Make sure that the collected trash has been dumped.

Important

To close the bucket lid, shift the bucket open/close lever to the "CLOSE" position and hold the lever position for 2 to 3 seconds. If the lever is released soon after shifted to the "CLOSE" position, the bucket lid will open and the collected cores, etc. will slip out.

10. Shift the bucket open/close lever to the "CLOSE" position to close the bucket.
11. Release the parking brake.
12. Travel forward slowly to a position where the bucket can be lowered if needed.
13. Lower the bucket to its lowest position.
14. Apply the parking brake.
15. Fix the outriggers in the position for traveling and collecting.

Handling Instructions

Transporting

Transporting Procedure

Important

When loading or unloading the machine, raise the bucket 10 cm (3.94 in). Otherwise, the bucket lid may hit a loading ramp etc.

When loading this machine into a trailer or a truck to transport it, drive the machine in reverse. When unloading, drive the machine forward.

After loading or unloading, lower the bucket to the lowest position.

Cleaning after Use

The purpose of the machine cleaning is to:

- Prevent accidents
- Prevent damage to the machine
- Maintain machine performance

Properly clean the machine to maintain its functionality and performance.

If you detect any abnormalities with the machine, immediately perform maintenance or repairs.

Engine

Cleaning of Engine-Associated Parts

Caution

Perform operations after the muffler, engine and other parts have sufficiently cooled. Otherwise, you may get burned.

1. Clean clippings and remove dirt.
2. Blow compressed air to clean any grass or flammable materials that may be attached on or around the muffler.

Main Vehicle

Cleaning of Bucket Interior

Warning

To keep the position of raised bucket, be sure to lock it with the cylinder lock.

Be sure to clean the interior of the bucket after work.

1. Raise the bucket and open the bucket lid.
2. Secure the bucket position with the cylinder lock.
3. Wash the interior of the bucket with water.
4. Dry it thoroughly after washing with water.

Cleaning of Sweeper Section

Important

Dirty inside of the brush frame may reduce the collection capacity, causing premature wear of parts and abnormal vibration or damage due to high loads.

Be sure to wash with water.

Be sure to clean the the sweeper section after work.

1. Raise the bucket.
2. Stop the engine.
3. Secure the bucket position with the cylinder lock.
4. Remove the brush cover.
5. Wash the inside of the rotary, inside of the brush frame and the rollers with water.
6. Dry them thoroughly after washing with water.

Handling Instructions

Storage

Short-Term Storage

Short-term storage means that the machine is temporarily stored (within 1 month) without use.

Follow the instructions below for short-term storage of the machine.

1. Cleaning

- Remove dirt, grass clippings, oil stains etc. completely from the main vehicle and engine.

2. Storage location

- Cover the machine and store it in a dry place where it will not be exposed to rain.

Precautions for Maintenance	Page 6-2
Jacking Up The Machine	Page 6-2
About Jacking Up The Machine	Page 6-2
Jack-up Points	Page 6-2
Inspection and Cleaning	Page 6-3
Engine	Page 6-3
Main Vehicle	Page 6-4
Supplying Fluids	Page 6-5
Engine	Page 6-5
Main Vehicle	Page 6-6
Greasing	Page 6-8
About Greasing	Page 6-8
Greasing Points	Page 6-9
Lubrication	Page 6-12
About Lubrication	Page 6-12
Lubricating Points	Page 6-12
Adjustment	Page 6-13
Main Vehicle	Page 6-13
Replacement	Page 6-18
Engine	Page 6-18
Main Vehicle	Page 6-20
Storage	Page 6-28
Long-Term Storage	Page 6-28

Maintenance

Precautions for Maintenance

Warning

The chapter "Maintenance" in this manual describes practical measures which should be performed by a mechanic with expertise. The owner should instruct the mechanic with expertise to perform maintenance service for this machine.

Caution

First, learn well the operations you plan to perform.

Important

Use tools appropriate for each operation.

Important

Use Baronsess genuine parts for replacement and accessories. Our product warranty may be void if you use non-genuine parts for replacement or accessories.

Jacking Up The Machine

About Jacking Up The Machine

Warning

When replacing a tire or beginning any other maintenance or repairs, be sure to chock the wheels to prevent the machine from moving. Before jacking up the machine, park it on a hard, flat surface such as a concrete floor and remove any obstacles that could prevent you from performing the work safely. When necessary, use an appropriate chain block, hoist, or jack. Support the machine securely with jack stands or appropriate blocks. Failure to do so may cause the machine to move or fall, resulting in injury or death.

Important

Only place a jack under the jack-up points specified. Placing a jack at any other point will result in damage to the frame or other parts.

Use the jack-up points identified in this manual when jacking up the machine.

Jack-up Points

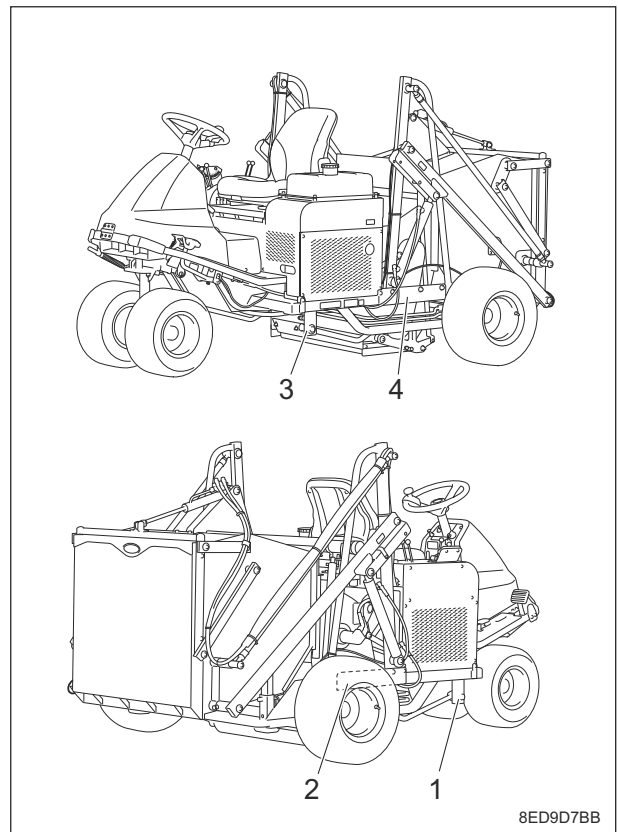

Jack-up Points_001

1	Right front brush frame mount area
2	Right rear frame area
3	Left front brush frame mount area
4	Left rear frame area

1. Right front brush frame mount area

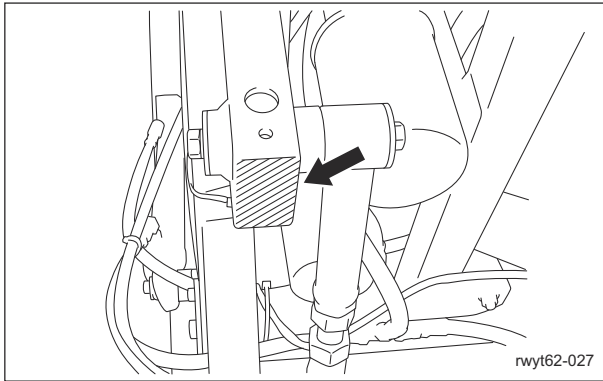

Jack-up Points_002

2. Right rear frame area

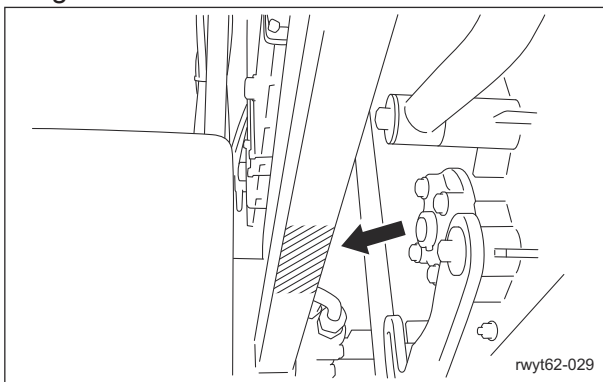

Jack-up Points_003

3. Left front brush frame mount area

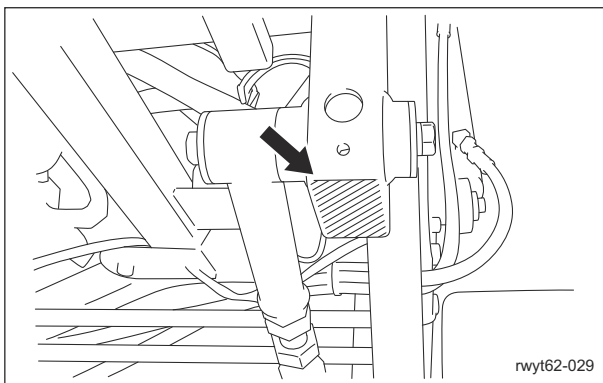

Jack-up Points_004

4. Left rear frame area

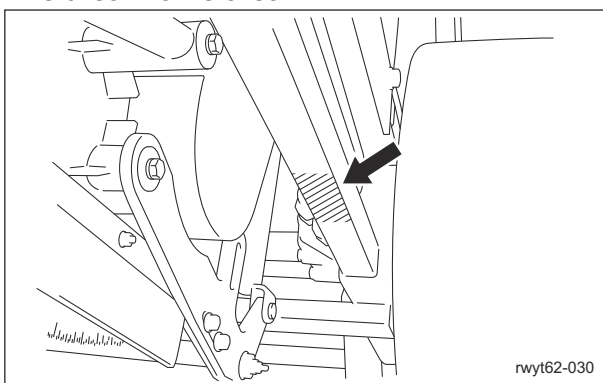

Jack-up Points_005

Inspection and Cleaning

Inspect and clean the machine with the goals of the followings.

- Accident prevention
- Failure prevention
- Performance retention

Make efforts for early detection of the machine failure and prevention of the sudden occurrence of trouble.

Perform maintenance and repair works immediately if any abnormality is found in the machine.

Engine

Cleaning of Air Cleaner Element

1. Open the underseat cover.

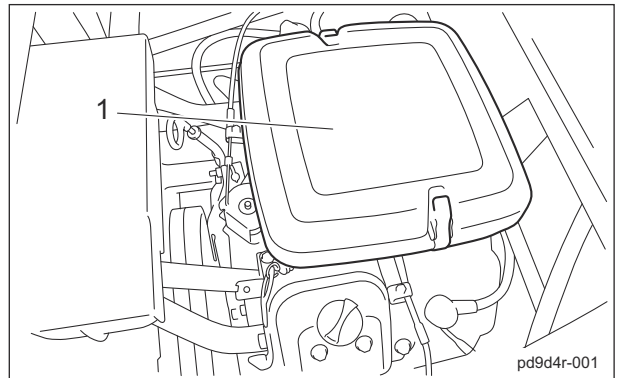

Cleaning of Air Cleaner Element_001

- | | |
|---|-------------|
| 1 | Air cleaner |
|---|-------------|

2. Remove the clip, and then remove the cover.
3. Remove the knob and plate, and then remove the air cleaner filter.
4. Remove the pre-cleaner from the air cleaner filter.

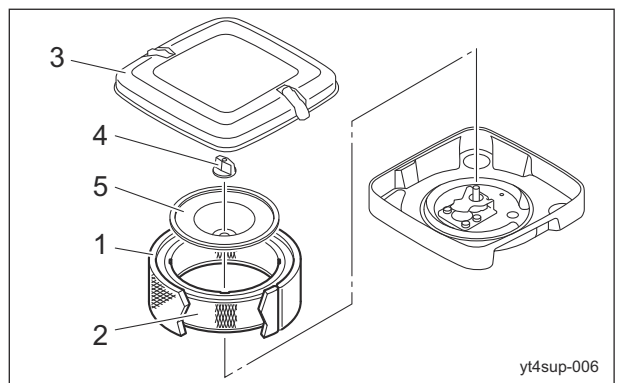

Cleaning of Air Cleaner Element_002

Maintenance

1	Pre-cleaner
2	Air cleaner filter
3	Cover
4	Knob
5	Plate

Important

When cleaning the air cleaner filter, do not use a petroleum solvent.
 When cleaning and drying the air cleaner filter, do not use compressed air.
 Do not infiltrate oil with the pre-cleaner.

5. Rinse the pre-cleaner with liquid detergent and dry it out by pressing with clean cloth.
6. While paying close attention not to damage the air cleaner filter, tap a solid portion of the air cleaner filter to remove dust and dirt. If the air cleaner filter is damaged or dirty, replace it.
7. Install the air cleaner filter and pre-cleaner.
8. Install the plate and knob.
9. Install the cover, and then fix it securely using the clip.
10. Close the underseat cover.

Cleaning of Fuel Strainer

If the fuel strainer becomes clogged with dust and dirt, the fuel flow will become insufficient. Periodically clean it.

Important

Shut off the fuel valve, and then clean the fuel strainer in a clean location, free of dust and dirt.

1. Open the underseat cover.

2. Remove the filter pot, wash the filter and inside of the filter pot using a solvent, such as a hardly flammable kerosene, and then blow compressed air to dry them.

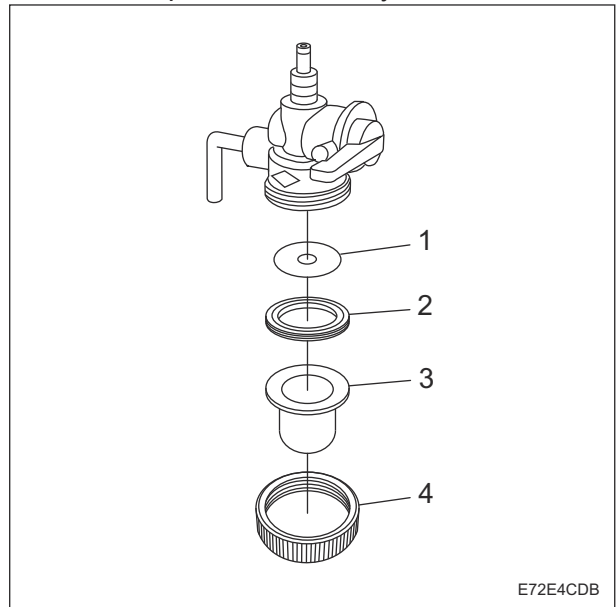

Cleaning of Fuel Strainer_001

1	Filter
2	Packing
3	Filter pot
4	Ring

3. Make sure that there is no fuel leakage after it is installed.
4. Close the underseat cover.

Main Vehicle

Inspection of Hydraulic Hoses and Pipes

Warning

When checking the hydraulic circuit for pinhole leaks or oil leakage from nozzles, do not use your hands. Use items such as paper or corrugated cardboard to find leakage points.

Be extremely careful with high-pressure oil as it may pierce your skin, resulting in personal accidents.

If fluid is injected into the skin it must be surgically removed within a few hours by a doctor familiar with this form of injury or gangrene may result.

1. Make sure that there is no wear, deterioration or damage in the hydraulic hoses and pipes.

2. Make sure that there is no looseness in the connecting portion of the hydraulic hoses and pipes.
3. Check underneath the machine for hydraulic oil leakage.

Inspection of Belts

Warning

Be sure to stop the engine before inspecting the belts.

Warning

If you have removed any covers, etc., during inspection, make sure that you securely re-attach them in their original positions. If covers, etc., remain removed, the operator or the mechanic may come into contact with rotating parts or belts, and foreign objects may fly off, possibly resulting in injuries.

1. Press the middle of the belt with your finger to check the belt tension.
2. Make sure that there are no cracks, damage or abnormal wear.

Inspection of Electrical Wiring

Important

Electrical short circuit will cause fire, electrical leakage and malfunction of electrical equipments.

1. Make sure that there is no defacement in wires and terminals.
2. Make sure that there is no deterioration or damage in wires and terminals.
3. Make sure that there is no looseness in wiring connections.
4. Make sure that there is no poor terminal connection.

Inspection of Wheel Mounting Bolt

Important

Tighten the wheel mounting bolts on the specified torque by using a torque wrench.

1. Check the wheel mounting bolts and wheel nuts for looseness and coming off.
2. Check the wheel mounting bolts and wheel nuts for cracks and damages.

3. Check the wheel mounting bolts and wheel nuts for rust.
4. Check around the wheel mounting bolts and wheel nuts for traces of rust fluid.
5. Check the wheel mounting bolts for unequal bolt length.
6. Check the wheel mounting bolts and wheel nuts for stripped threads and abrasion.

Supplying Fluids

Engine

Supply of Engine Oil

Important

Do not fill too much engine oil. Otherwise, the engine may be damaged.

Important

Do not mix different types of engine oil.

Important

Be sure to use engine oil that is classified as API Service Grade SF or higher, with an SAE Viscosity that is appropriate for the operating environment (ambient temperature).

Important

Securely install the oil level gauge and oil filler cap.

If the engine oil level is lower than the lower limit line on the oil level gauge, supply engine oil.

Supply engine oil through the oil filler port.

1. Place the machine so that the engine is level.
2. Stop the engine.
3. Open the underseat cover.

Maintenance

4. Remove the oil filler cap.

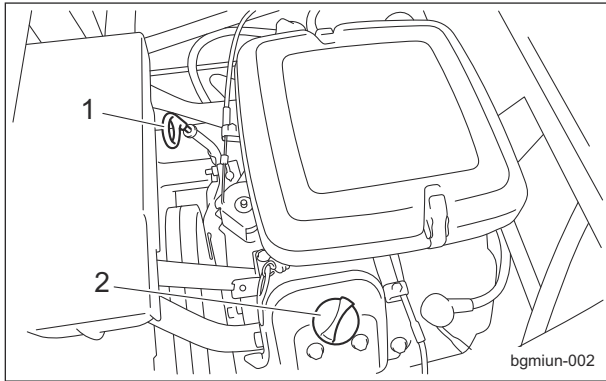

Supply of Engine Oil_001

1	Oil level gauge
2	Oil filler cap

5. Supply new engine oil through the oil filler port.
Supply oil until it reaches a level in between the upper and lower limit lines on the oil level gauge.
6. Install the oil filler cap.
7. It will take a while for the supplied engine oil to descend into the oil pan.
Check the oil level again 10 to 20 minutes after supplying the oil.
If the oil level is low, supply oil again until it reaches the specified level.
8. Close the underseat cover.

Main Vehicle

Supply of Hydraulic Oil

Caution

Keep fire away while supplying the hydraulic oil.
Do not smoke.

Important

Supply hydraulic oil after checking the oil in the hydraulic tank has been sufficiently cooled down.
Oil level changes depending on the hydraulic oil temperature.

Important

Do not mix different types of oil.

Important

For the hydraulic oil to be used, consult Characteristics of Hydraulic Oil and use the oil whose characteristics are equivalent or superior to those specified there.
Especially regarding kinematic viscosity and viscosity index, use of hydraulic oil whose figures are less than those of the specified hydraulic oil will cause a malfunction in the hydraulic circuit.

■ Characteristics of Hydraulic Oil

ISO Viscosity Grade		ISO VG46
Density	15 °C (59 °F)	0.873 g/cm ³ (0.0315 lb/in ³)
API Gravity		30.6
Flash Point (Open Cup)		230 °C (446 °F)
Pour Point		-30 °C (-22 °F)
Kinematic	40 °C (104 °F)	46 mm ² /s (46 cSt)
Viscosity	100 °C (212 °F)	7 mm ² /s (7 cSt)
Viscosity Index		109

■ Characteristics of Hydraulic Oil with conditions of use

Hydraulic oil of ISO viscosity grade VG68 can be used only if the following condition is met:

- The outside temperature must be 20 °C (68 °F) or more during engine operation.

ISO Viscosity Grade		ISO VG68
Density	15 °C (59 °F)	0.878 g/cm ³ (0.0318 lb/in ³)
API Gravity		29.7
Flash Point (Open Cup)		252 °C (486 °F)
Pour Point		-30 °C (-22 °F)
Kinematic	40 °C (104 °F)	68 mm ² /s (68 cSt)
Viscosity	100 °C (212 °F)	9 mm ² /s (9 cSt)
Viscosity Index		107

Note:

In Japan, "Shell Tellus S2M46 (ISO VG46)" and "Shell Tellus S2M68 (ISO VG68)" meet the characteristics described above.
However, in other countries, the specification of Shell Tellus S2M46 and Shell Tellus S2M68 can be below what is required.
Please check the product data sheet to ensure that it meets the requirements before using.

1. Remove the knobs, and then open the front cover.

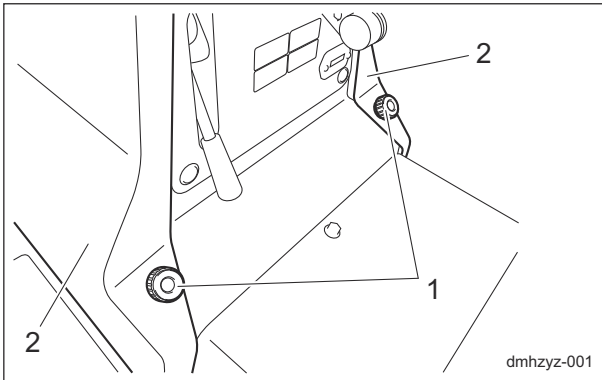

Supply of Hydraulic Oil_001

1	Knobs
2	Front cover

2. Remove the bolts, and then open the cover.

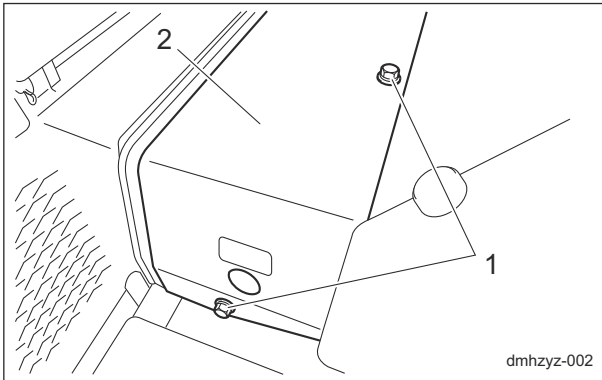

Supply of Hydraulic Oil_002

1	Bolt
2	Cover

3. If the hydraulic oil level is low, follow the steps below to supply oil.

[1] Open the tank cap, and then supply hydraulic oil through the oil filling port until the oil level reaches the middle of the oil gauge on the hydraulic tank.

[2] Tighten the tank cap securely.

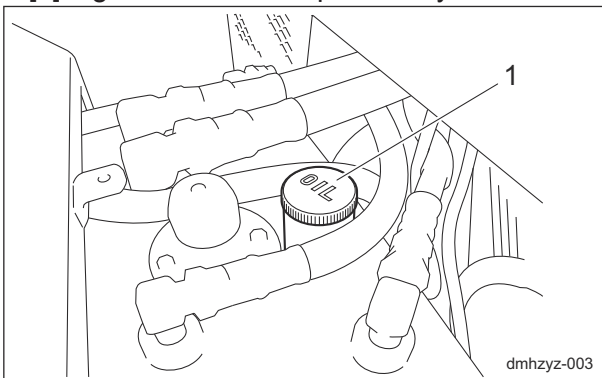

Supply of Hydraulic Oil_003

1	Tank cap
---	----------

4. Start the engine, and then repeat the steps below a few times.

- Raise and lower the brush frame.
- Raise and lower the bucket.

5. Lower the brush frame and the bucket and maintain that position on a level surface, and then check to see if the oil level is at the middle of the oil gauge.

If the hydraulic oil level is low, supply oil again until it reaches the specified level.

6. Check underneath the machine for oil leakage.

7. Install the cover.

8. Close the front cover.

Maintenance

Supply of Battery Fluid

Danger

If battery fluid comes into contact with eyes, it may result in blindness. Immediately flush with plenty of water and take medical care from an ophthalmologist.

Danger

Do not drink battery fluid. If battery fluid enters the mouth or is swallowed, it may result in burns inside the mouth. Immediately and repeatedly gargle with plenty of water, then drink plenty of water, and take medical care.

Danger

When you supply battery fluid, wear protective garments and safety glasses, etc.

Warning

If battery fluid adheres to the skin or clothing, it may cause burns or damage clothing. Immediately flush with plenty of water, then wash thoroughly with soap.

Warning

Do not allow the battery fluid level to become lower than the LOWER LEVEL (minimum fluid level line). The battery may explode if it is used or charged while the battery fluid level is at the LOWER LEVEL (minimum fluid level line).

Warning

When refilling, do not fill purified water above the UPPER LEVEL (maximum fluid level line). Doing so may result in electrolyte leaks.

Caution

Implement after the engine and muffler etc. have well cooled down. Otherwise, you may get burned.

Important

If battery fluid adheres to the vehicle, it may cause corrosion. Wipe it off with a cloth dampened with water, and then flush with water.

If the battery fluid level is lower than halfway between the UPPER LEVEL (maximum fluid level line) and LOWER LEVEL (minimum fluid level line), add purified water.

1. Loosen the vent plug and remove it.
2. Add purified water up to the UPPER LEVEL (maximum fluid level line)
3. Tighten the vent plug securely.

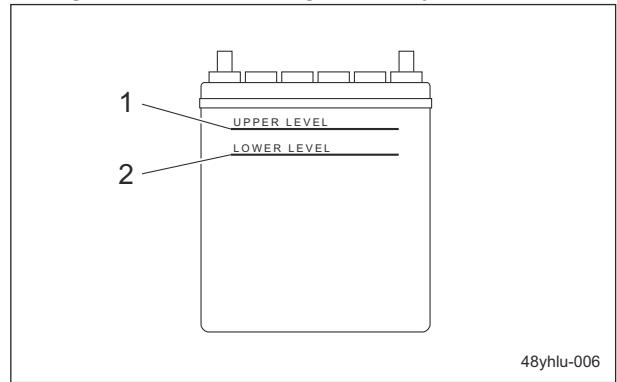

Supply of Battery Fluid_001

1	Maximum fluid level line
2	Minimum fluid level line

Greasing

About Greasing

Since there may be adhesion or damage due to lack of grease on moving parts, they must be greased.

Add urea-based No. 2 grease in accordance with the Maintenance Schedule.

Other locations where the specified grease or lubricant is used are indicated in "Greasing Points".

Add grease using the specified grease or lubricant.

Greasing Points

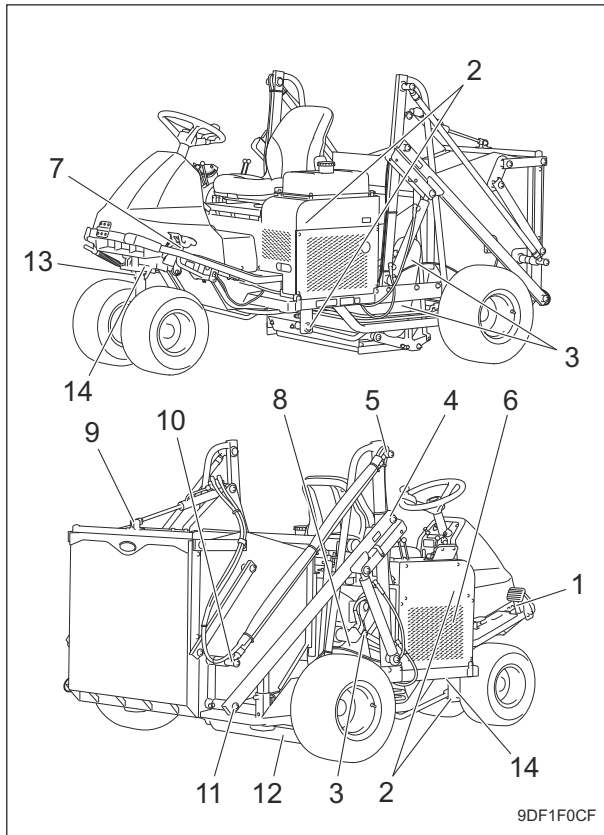

Greasing Points_001

	Location	No. of Greasing Points
1	Traveling pedal fulcrum	1
2	Brush frame fulcrum	4
3	Flange bearing	3
4	Upper connecting pipe	2
5	Upper adjusting pipe	2
6	Belt tension lever fulcrum (lower pulley for pump)	1
7	Brake pedal fulcrum	1
8	Pump neutral lever fulcrum (upper piston pump)	1
9	Bucket lid cylinder	1
10	Lower adjusting pipe	2
11	Lower connecting pipe	2
12	Rear roller	2
13	Front wheel arm	1
14	Tie rod end (#11554-)	2

1. Traveling pedal fulcrum

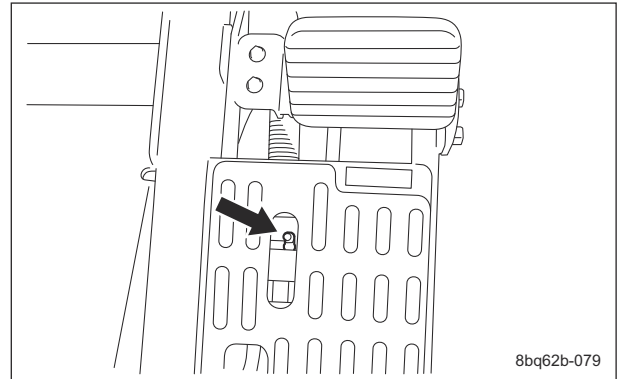

Greasing Points_002

2. Brush frame fulcrum

There is one point each on the upper, lower, left and right.

Upper

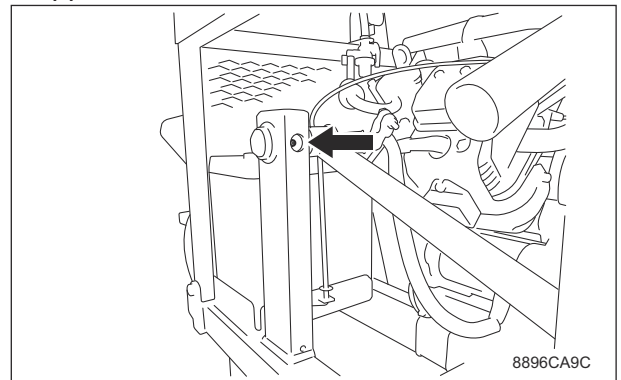

Greasing Points_003

Lower

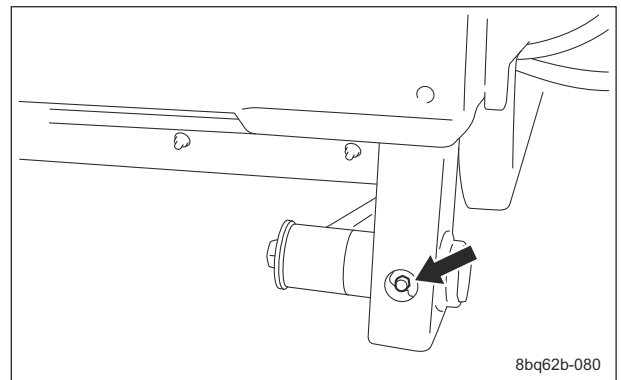

Greasing Points_004

Maintenance

Maintenance

3. Flange bearing

There are three points on the left and right

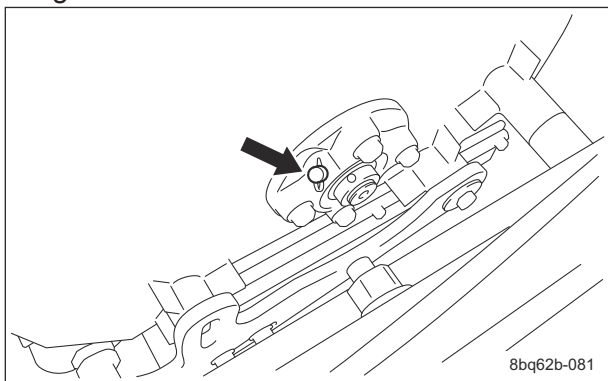

Greasing Points_005

Upper left

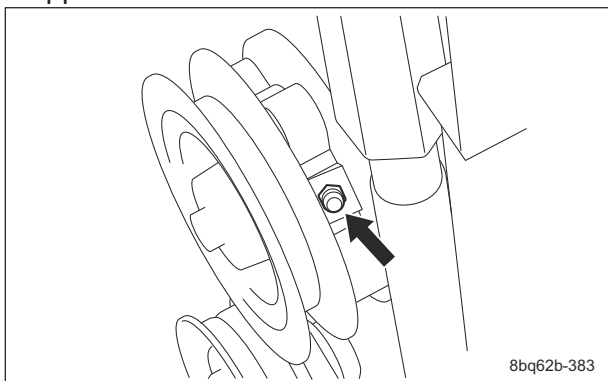

Greasing Points_006

Lower left

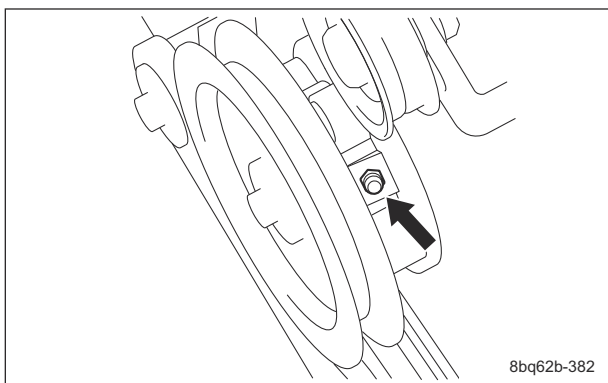

Greasing Points_007

4. Upper connecting pipe

There is one point each on the left and right.

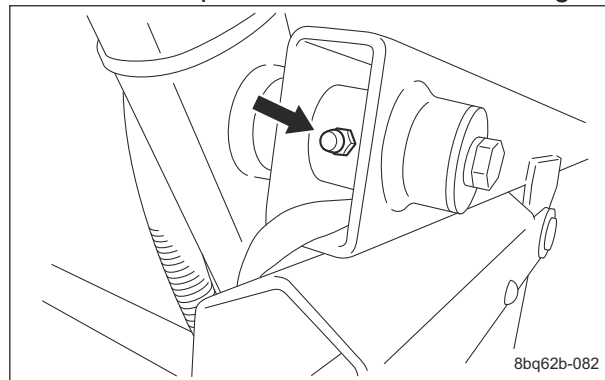

Greasing Points_008

5. Upper adjusting pipe

There is one point each on the left and right.

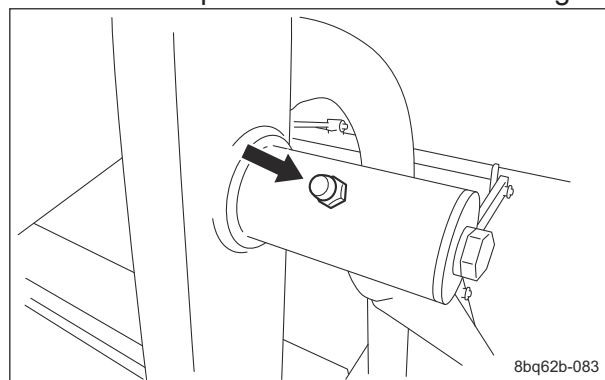

Greasing Points_009

6. Belt tension lever fulcrum (lower pulley for pump)

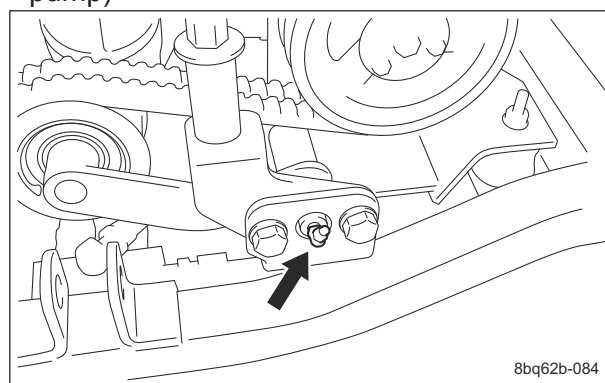

Greasing Points_010

7. Brake pedal fulcrum

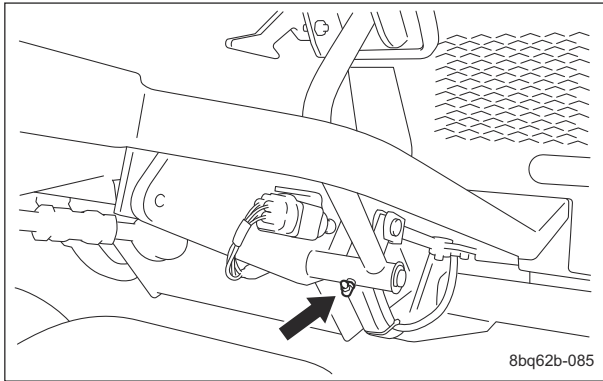

Greasing Points_011

8. Pump neutral lever fulcrum (upper piston pump)

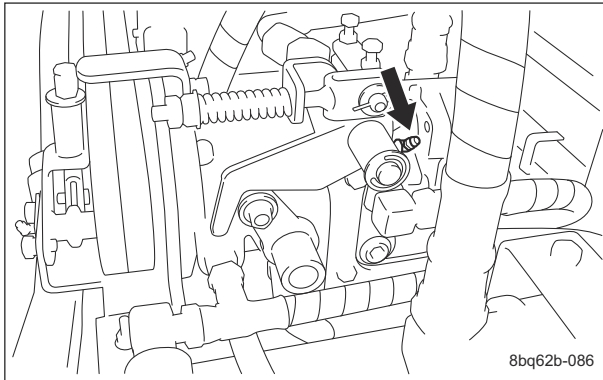

Greasing Points_012

9. Bucket lid cylinder

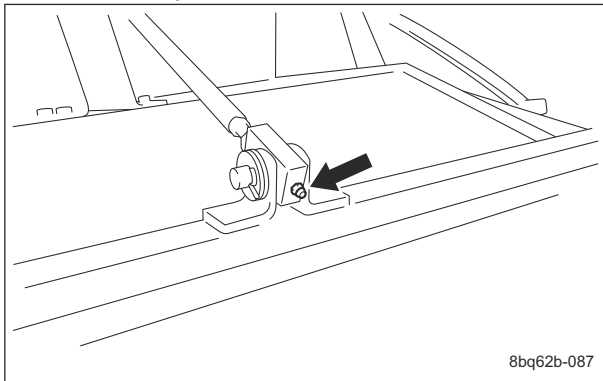

Greasing Points_013

10. Lower adjusting pipe

There is one point each on the left and right.

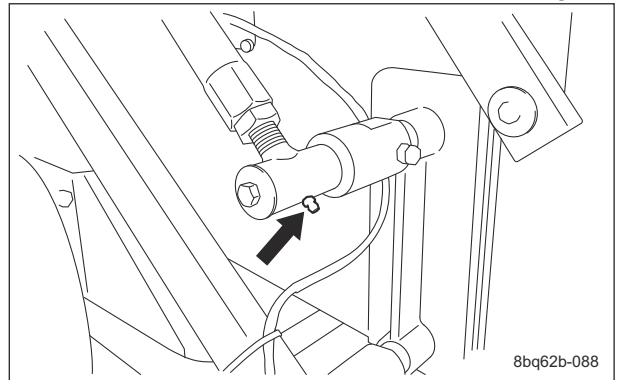

Greasing Points_014

11. Lower connecting pipe

There is one point each on the left and right.

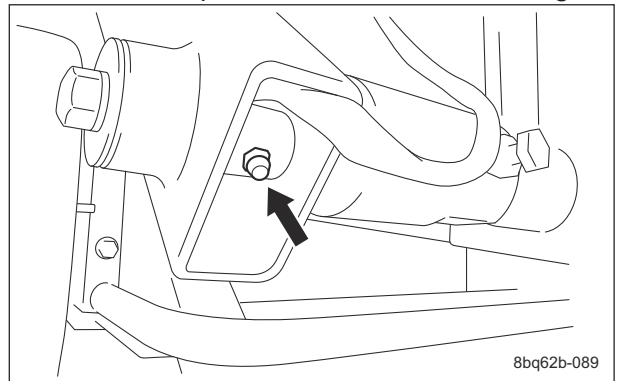

Greasing Points_015

12. Rear roller

There is one point each on the left and right.

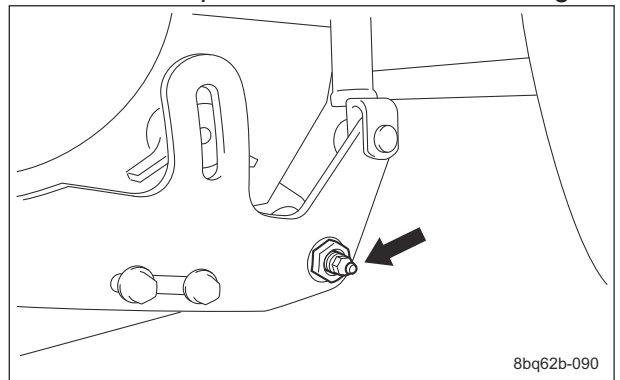

Greasing Points_016

Maintenance

13. Front wheel arm

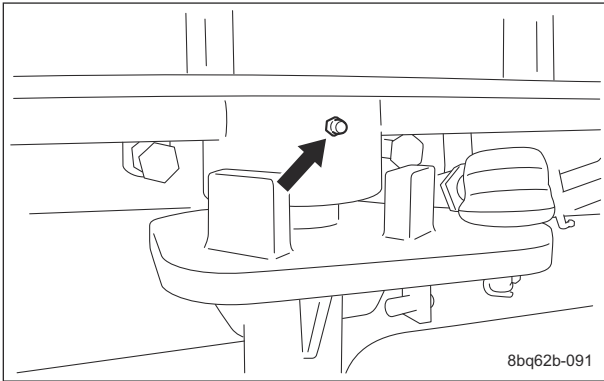

Greasing Points_017

14. Tie rod end

There are two points.

Add 9 g (0.02 lb) of DYNAMAX GREASE EP NO.1 every 3 months of operation.

Note:

The appropriate greasing amount is that it sticks out a little from the tie rod end rubber boot.

Front wheel arm side

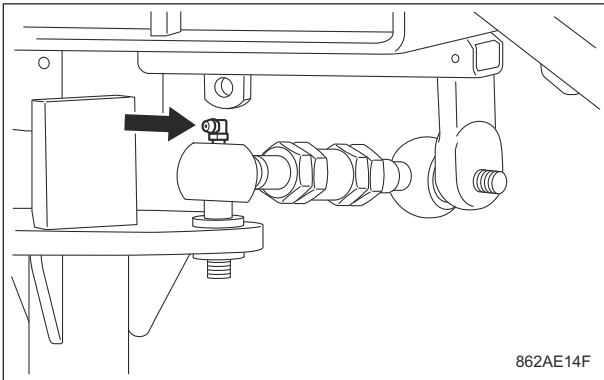

Greasing Points_018

Steering gearbox side

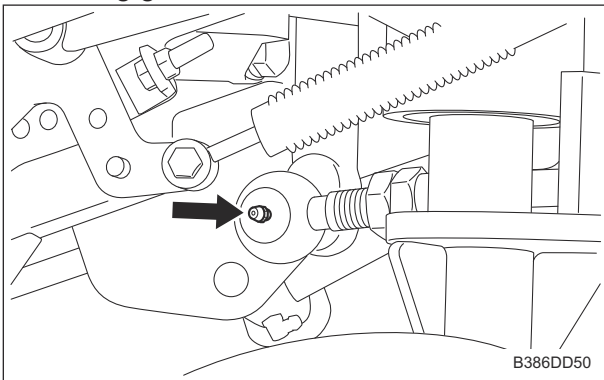

Greasing Points_019

Lubrication

About Lubrication

It is necessary to lubricate moving parts so that they will not become stuck or damaged.

The locations where lubricant is used are indicated in "Lubricating Points".

Apply the lubricant.

Lubricating Points

Apply lubricant at the following locations every 50 hours of operation.

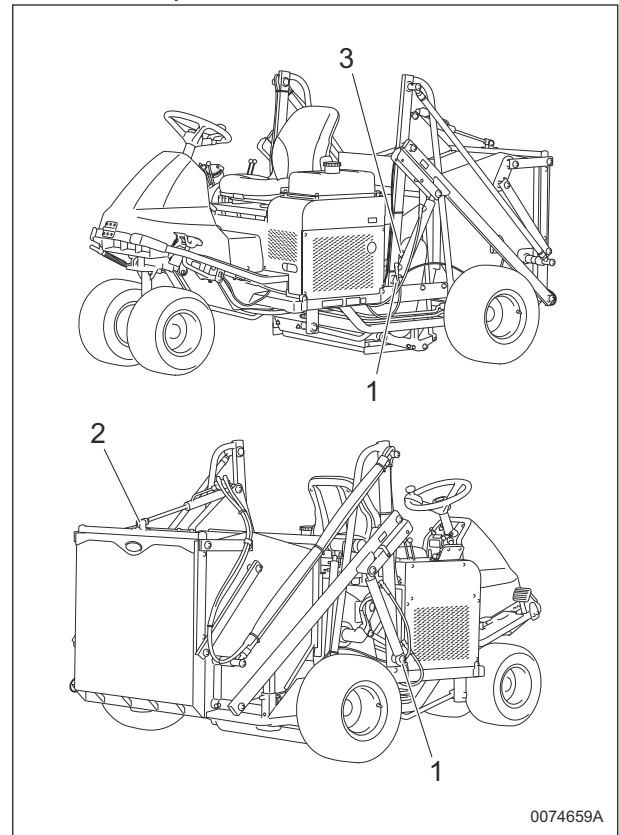

Lubricating Points_001

	Location	No. of lubricating points
1	Bucket up/down cylinder spherical bearing	2
2	Bucket lid open/close cylinder spherical bearing	1
3	Brush frame up/down cylinder spherical bearing	1

1. Bucket up/down cylinder spherical bearing
There is one point each on the left and right.

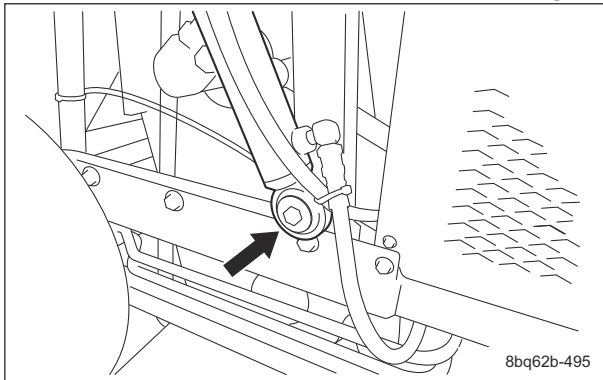

Lubricating Points_002

2. Bucket lid open/close cylinder spherical bearing
There is one point.

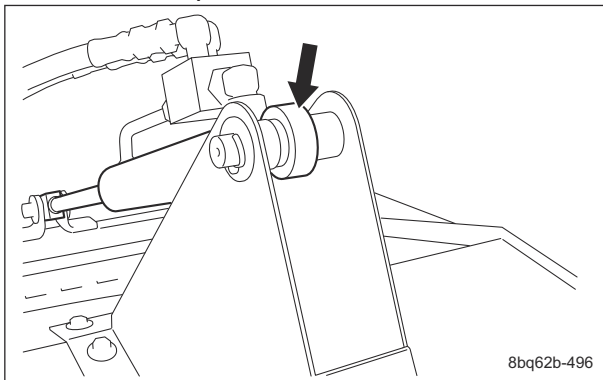

Lubricating Points_003

3. Brush frame up/down cylinder spherical bearing
There is one point.

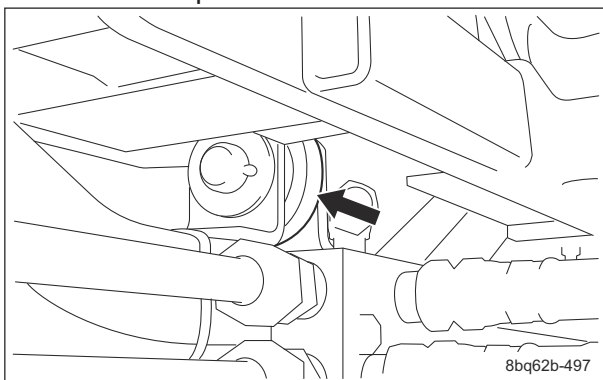

Lubricating Points_004

Adjustment

Main Vehicle

Adjustment of Brushes

Caution

For maintenance service, raise the empty bucket.

Important

If the brush operation height is inadequate, cores will not be properly collected.

Important

If the left and right sides of the brushes are at different heights, the cores will not be uniformly collected, and the brushes will wear unevenly.

If the rotary brush becomes too short, adjust the positions of the brush tips.

1. Move the machine to level ground.
2. Apply the parking brake.
3. Raise the bucket to its highest position.
4. Stop the engine.

Warning

To keep the position of raised bucket, be sure to lock it with the cylinder lock.

5. Lock the bucket with the cylinder lock.
6. Remove the brush cover.
7. Loosen the bolts securing the brush.

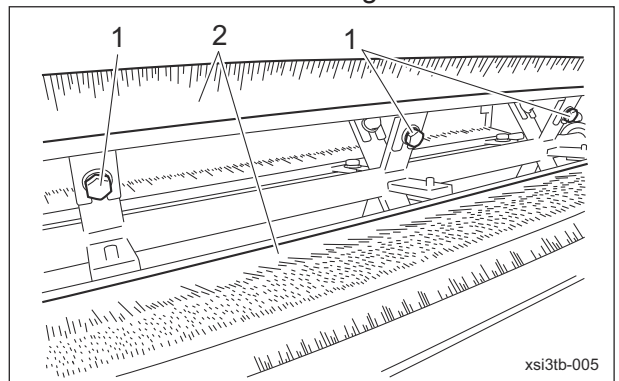

Adjustment of Brushes_001

1	Bolt
2	Brush

Maintenance

Important

Evenly install the brush.

- Adjust the brush so that there is a clearance of approximately 5 mm (0.20 in) between its tip and the brush frame, and then temporarily tighten the bolts.

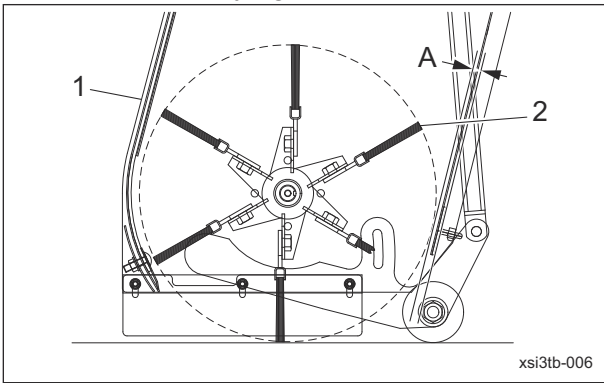

Adjustment of Brushes_002

1	Brush frame
2	Tip of rotary brush
A	5 mm (0.20 in)

- Slowly rotate the rotary brushes by hand, and then follow the same steps to adjust the remaining brushes and temporarily tighten the bolts.
- Slowly rotate the rotary brushes by hand, check the clearance again and tighten the bolts so that all the clearances between the brush tips and the brush frame will be the same.
- After making adjustments of all the brushes and tightening the bolts, tighten all bolts firmly.
- Install the brush cover.
- Start the engine, rotate the brushes, and then check that there is no contact between or vibration in the brushes and brush frame.

Adjustment of Rotary Plates

Caution

For maintenance service, raise the empty bucket.

Important

Adjust all rotary plates properly. Otherwise vibration may occur, causing damage or an accident.

Important

If the gap between the rotary plates and brush frame is not appropriate, cores will not be properly collected.

- Move the machine to level ground.
- Apply the parking brake.
- Raise the bucket to its highest position.
- Stop the engine.

Warning

To keep the position of raised bucket, be sure to lock it with the cylinder lock.

- Lock the bucket with the cylinder lock.
- Remove the brush cover.
- Loosen the bolts securing the rotary plate.

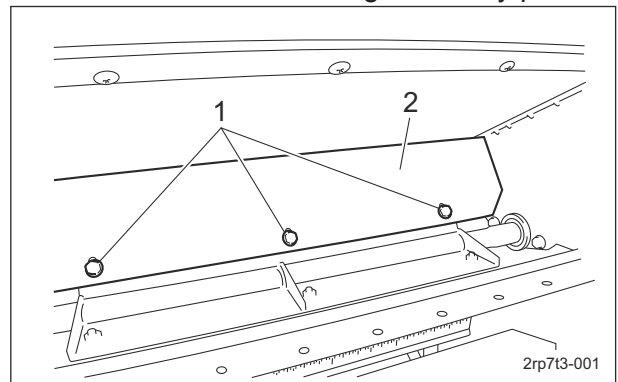

Adjustment of Rotary Plates_001

1	Bolt
2	Rotary plate

Important

Evenly install the rotary plate.

- Adjust the rotary plate so that there is a clearance of approximately 5 mm (0.20 in) between it and the brush frame, and then temporarily tighten the bolts.

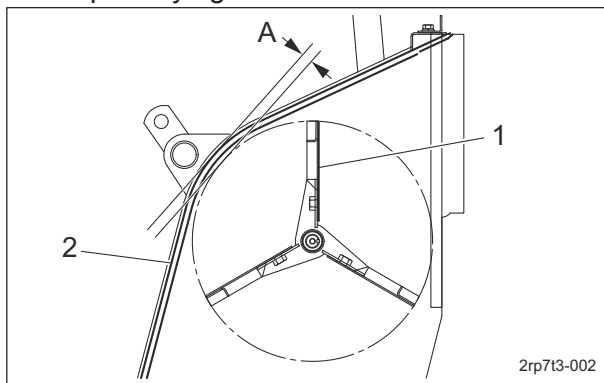

Adjustment of Rotary Plates_002

1	Rotary Plates
2	Brush frame
A	5 mm (0.20 in)

- Slowly rotate the rotary plates by hand, and then follow the same steps to adjust the remaining rotary plates and temporarily tighten the bolts.
- Slowly rotate the rotary plates by hand, check the clearance again and tighten the bolts so that all the clearances between the rotary plates and the brush frame will be the same.
- After making adjustments of all the rotary plates and tightening the bolts, tighten all bolts firmly.
- Install the brush cover.
- Start the engine, rotate the rotary plates, and then check that there is no contact between or vibration in the rotary plates and brush frame.

Adjustment of Front Apron

Caution

Be sure to stop the engine before adjusting the front apron.

Important

Check that the front apron and front apron adjusting plate are installed straight, with the left and right sides at the same height.

Important

Adjust the height of the front apron according to the core size and quantity.

- Loosen the flange nut.

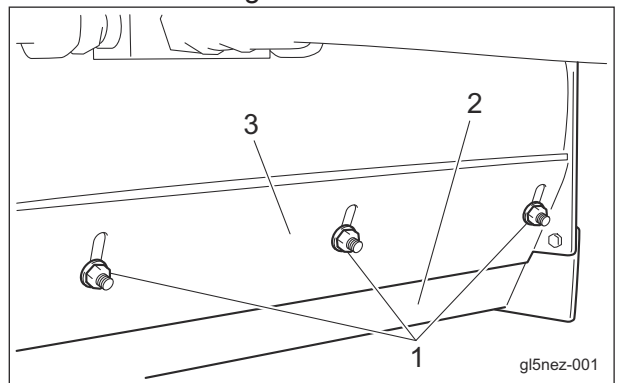

Adjustment of Front Apron_001

1	Flange nut
2	Front apron
3	Front apron adjusting plate

Important

Tighten the nut until 3 or 4 bolt threads are visible.

- Adjust the front apron and front apron adjusting plate, and then tighten the flange nut.

[1] When to lower the apron

- Small cores
- Small quantity
- Cores fly out in front of the front apron.

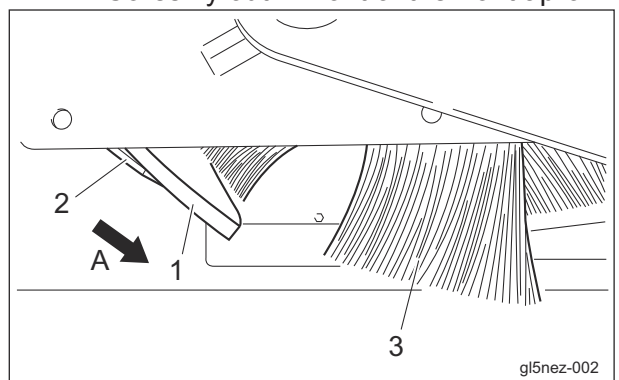

Adjustment of Front Apron_002

Maintenance

1	Front apron
2	Front apron adjusting plate
3	Brush
A	Lower

[2] When to raise the apron

- Large cores
- Large quantity
- Cores are pressed down by the apron.

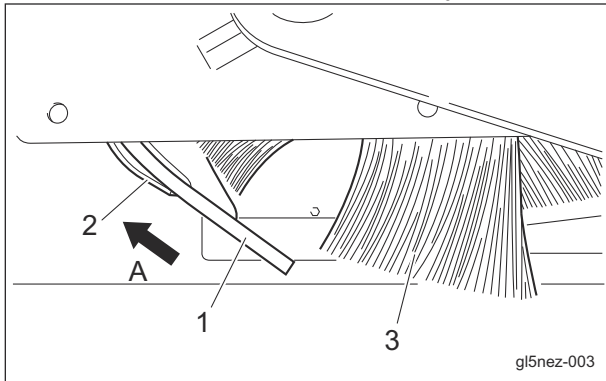

Adjustment of Front Apron_003

1	Front apron
2	Front apron adjusting plate
3	Brush
A	Raise

Adjustment of Belt Tension

Warning

Be sure to stop the engine before adjusting the belts.

Important

For the specified value of belt tension, refer to Adjusted Values. Before making sure of belt tension, rotate the belt several times.

■ Adjustment of Pump Drive Belt

1. Move the machine to a level ground.
2. Apply the parking brake.
3. Lower the brush frame and the bucket.
4. Stop the engine.
5. Open the underseat cover.

6. Check the belt tension.

The criterion for the belt tension is that the belt slacks approximately 10 mm (0.39 in) when you apply a force of 98 N (10 kgf) with your finger to the belt at the middle point between the pulleys (arrow in the diagram).

7. If the belt tension is not at the approximate value, follow the steps below to adjust it.

[1] Loosen the nut.

[2] Adjust the belt tension with high nut.

- Tighten the high nut to increase the belt tension.
- Loosen the nut to reduce the belt tension.

[3] Tighten the high nut until there is no clearance between the spring cover and the tension fulcrum fitting.

[4] Lock it with the nut.

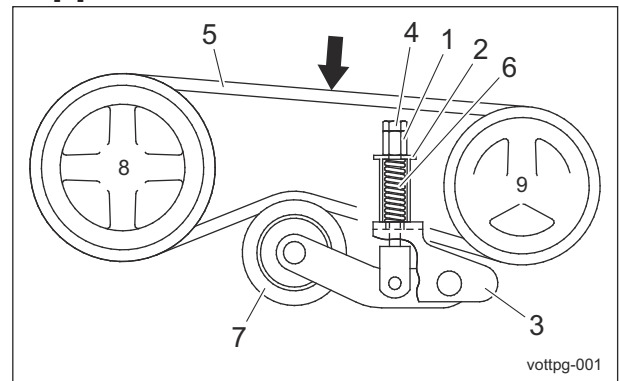

Adjustment of Pump Drive Belt_001

1	High nut
2	Spring cover
3	Tension fulcrum fitting
4	Nut
5	Belt
6	Spring
7	Tension pulley
8	Engine pulley
9	Pump pulley

8. After adjustment of the belt tension, check the belt tension again.

If the belt tension is still not at the approximate value after repeating the adjustment several times, replace the belt with a new one.

9. Close the underseat cover.

■ Adjustment of Brush Belt

Important

If the brush belt is incorrectly adjusted, the brushes will not rotate properly.

1. Move the machine to a level ground.
2. Apply the parking brake.
3. Lower the brush frame and the bucket.
4. Stop the engine.
5. Remove the bolts.
6. Remove the belt cover.

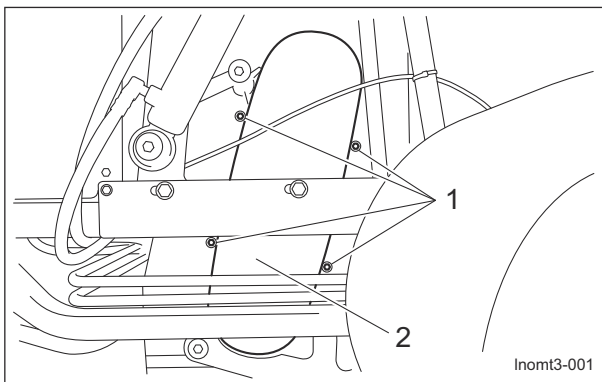

Adjustment of Brush Belt_001

1	Bolt
2	Belt cover

7. Check the belt tension.
The criterion for the belt tension is that the belt slacks approximately 10 mm (0.39 in) when you apply a force of 98 N (10 kgf) with your finger to the belt at the middle point.
8. If the belt tension is not at the approximate value, follow the steps below to adjust it.
 - [1] Loosen the bolt.
 - [2] Adjust the tension pulley with the nut.
 - Tighten the nut to increase the belt tension.
 - Loosen the nut to reduce the belt tension.

[3] Tighten the bolt.

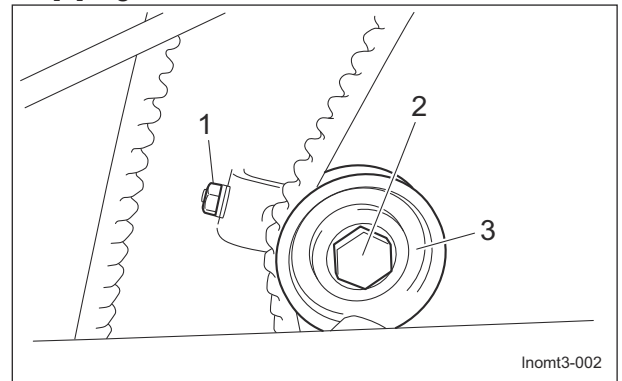

Adjustment of Brush Belt_002

1	Nut
2	Bolt
3	Tension pulley

9. After adjustment of the belt tension, check the belt tension again.
If the belt tension is still not at the approximate value after repeating the adjustment several times, replace the belt with a new one.
10. Install the belt cover.

Adjustment of Speed Adjusting Plate

⚠ Warning

Since it is dangerous, do not adjust while traveling.

The bolts can be used to adjust the height of the speed adjusting plate. The speed adjusting plate is used to maintain a fixed operation speed.

1. Loosen the bolts.
2. Determine the operation speed, adjust the height of the speed adjusting plate, and then tighten the bolts.

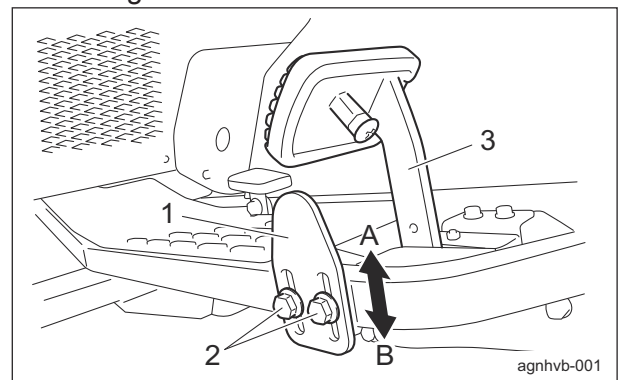

Adjustment of Speed Adjusting Plate_001

Maintenance

1	Speed adjusting plate
2	Bolt
3	Traveling pedal
A	Slower
B	Faster

Replacement

Engine

Replacement of Engine Oil

Caution

Be careful with hot oil, which could cause burns if it contacts your skin.

Important

When you change the engine oil, be sure to drain it into a bowl and discard it in accordance with local laws and regulations.

Important

Be sure to use engine oil that is classified as API Service Grade SF or higher, with an SAE Viscosity that is appropriate for the operating environment (ambient temperature).

Important

Securely install the oil level gauge and oil filler cap.

Change the engine oil more frequently, if the engine oil is contaminated, and especially if you use the machine in dusty areas or operate the engine at high loads or in high temperatures.

- Follow the steps below to remove the old engine oil.
 - [1] Start the engine to warm up the engine oil.
 - [2] With the machine on a level surface, stop the engine.
 - [3] Open the underseat cover.
 - [4] Remove the drain plug while the engine oil is warm, and then drain the old engine oil into a container.

- [5] Wind new sealing tape on the drain plug, and then re-place it to the engine.

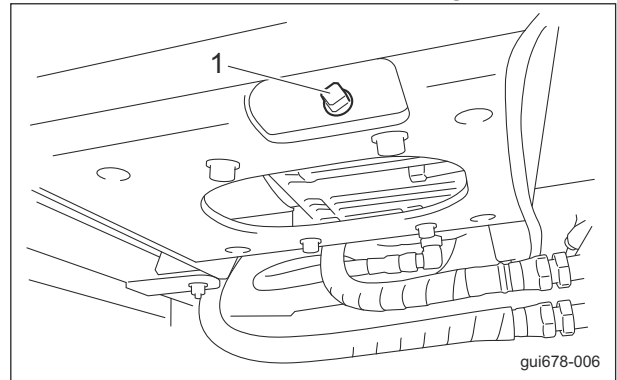

Replacement of Engine Oil_001

1	Drain plug
---	------------

- Remove the oil filler cap, and then supply new engine oil through the oil filler port until the oil reaches a level in between the upper and lower limit lines on the oil level gauge. The engine oil quantity is 1.0 dm³ (1.0 L).
- Pull out the oil level gauge, and wipe the oil off the oil level gauge cleanly with papers or cloths.
- Insert the oil level gauge all the way to check the oil level.
- After checking the level with the oil level gauge, supply more engine oil if it is insufficient. The engine oil quantity (including the oil filter) is approximately 1.6 dm³ (1.6 L).
- Install the oil filler cap.

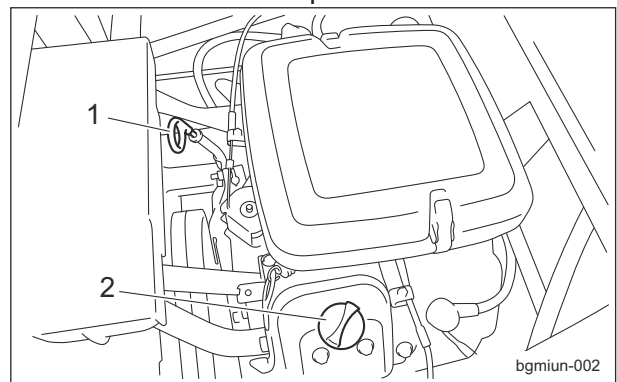

Replacement of Engine Oil_002

1	Oil level gauge
2	Oil filler cap

- It will take a while for the supplied engine oil to descend into the oil pan. Check the oil level again 10 to 20 minutes after supplying the oil.
- Close the underseat cover.

- Check underneath the machine for oil leakage.

Replacement of Engine Oil Filter

Caution

Be careful with hot oil, which could cause burns if it contacts your skin.

Important

When replacing the engine oil filter, be sure to drain the engine oil into a container and discard it in accordance with local laws and regulations.

Important

Be sure to use engine oil that is classified as API Service Grade SF or higher, with an SAE Viscosity that is appropriate for the operating environment (ambient temperature).

Important

Securely install the oil level gauge and oil filler cap.

- With the filter wrench, remove the old filter cartridge.

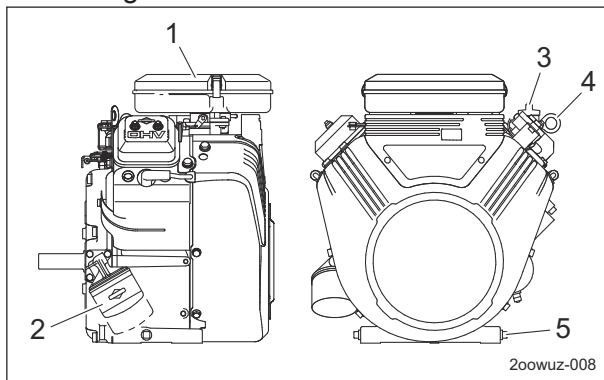

Replacement of Engine Oil Filter_001

1	Engine
2	Filter cartridge
3	Oil filler cap
4	Oil level gauge
5	Drain plug

- Lightly coat the packing of the new filter cartridge with engine oil.
- Hand-tighten the filter cartridge until the packing contacts the mounting surface, and then hand-tighten additional 1/2 turn.

- Supply engine oil until it reaches the specified level.
"Supply of Engine Oil" (Page 6-5)
- Start the engine, and then stop it after 10 to 20 minutes.
- Make sure that there is no oil leakage at the sealing surface of the filter cartridge.
- Check the engine oil level.
If it is low, supply engine oil until it reaches the specified level.
- Check underneath the machine for oil leakage.

Replacement of Air Cleaner Element

Important

A contaminated air cleaner element may cause malfunction of the engine.

- The timing for replacing the air cleaner element is described below.
 - Replace the air cleaner element in accordance with the Maintenance Schedule.
 - If it is significantly contaminated, replace it, even if the hours of operation do not exceed the specified time.
- Replace the air cleaner element by following the same steps as for cleaning the air cleaner element.
"Cleaning of Air Cleaner Element" (Page 6-3)

Maintenance

Replacement of Fuel Filter

Important

While installing the fuel filter, prevent contamination with dirt or dust. The fuel contaminated with dirt or dust will cause engine failure.

Important

Since the fuel filter is a cartridge, it cannot be disassembled or cleaned.

1. Remove the old fuel filter.
2. Install a new fuel filter with the arrow marked on it pointing toward the engine.

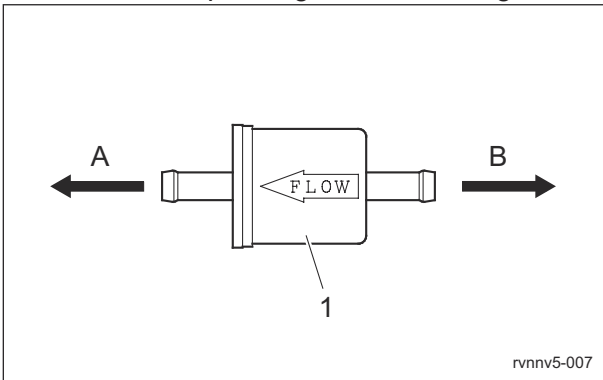

Replacement of Fuel Filter_001

1	Fuel filter
A	Engine
B	Fuel cock

Main Vehicle

Replacement of Hydraulic Oil

Caution

Be careful with hot oil, which could cause burns if it contacts your skin.

Important

When you change the hydraulic oil, be sure to drain it into a bowl and discard it in accordance with local laws and regulations.

Important

Supply hydraulic oil after checking the oil in the hydraulic tank has been sufficiently cooled down. Oil level changes depending on the hydraulic oil temperature.

Important

If the oil emulsifies or if it becomes even slightly less transparent, change the oil immediately.

Important

For the hydraulic oil to be used, consult Characteristics of Hydraulic Oil and use the oil whose characteristics are equivalent or superior to those specified there. Especially regarding kinematic viscosity and viscosity index, use of hydraulic oil whose figures are less than those of the specified hydraulic oil will cause a malfunction in the hydraulic circuit.

■ Characteristics of Hydraulic Oil

ISO Viscosity Grade		ISO VG46
Density	15 °C (59 °F)	0.873 g/cm ³ (0.0315 lb/in ³)
API Gravity		30.6
Flash Point (Open Cup)		230 °C (446 °F)
Pour Point		-30 °C (-22 °F)
Kinematic	40 °C (104 °F)	46 mm ² /s (46 cSt)
Viscosity	100 °C (212 °F)	7 mm ² /s (7 cSt)
Viscosity Index		109

■ Characteristics of Hydraulic Oil with conditions of use

Hydraulic oil of ISO viscosity grade VG68 can be used only if the following condition is met:

- The outside temperature must be 20 °C (68 °F) or more during engine operation.

ISO Viscosity Grade		ISO VG68
Density	15 °C (59 °F)	0.878 g/cm ³ (0.0318 lb/in ³)
API Gravity		29.7
Flash Point (Open Cup)		252 °C (486 °F)
Pour Point		-30 °C (-22 °F)
Kinematic Viscosity	40 °C (104 °F)	68 mm ² /s (68 cSt)
	100 °C (212 °F)	9 mm ² /s (9 cSt)
Viscosity Index		107

Note:

In Japan, "Shell Tellus S2M46 (ISO VG46)" and "Shell Tellus S2M68 (ISO VG68)" meet the characteristics described above. However, in other countries, the specification of Shell Tellus S2M46 and Shell Tellus S2M68 can be below what is required. Please check the product data sheet to ensure that it meets the requirements before using.

1. Follow the steps below to remove the old oil.
 - [1] Start and run the engine to warm up the oil.
 - [2] Lower the brush frame and the bucket on a level surface, and then stop the engine.
 - [3] Remove the drain plug of the hydraulic tank, and then drain the old oil into a container.
 - [4] Wind new sealing tape on the drain plug, and then attach it to the hydraulic tank.

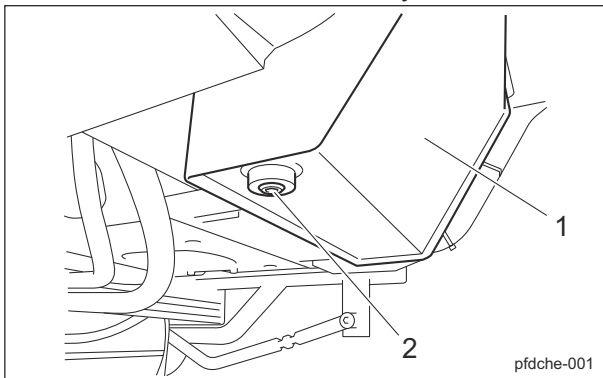

Replacement of Hydraulic Oil_001

1	Hydraulic tank
2	Drain plug

2. Open the tank cap, and then pour new oil from the fill port until the oil level reaches the middle of the oil gauge on the hydraulic tank.

The hydraulic tank capacity is approximately 17.0 dm³ (17.0 L).

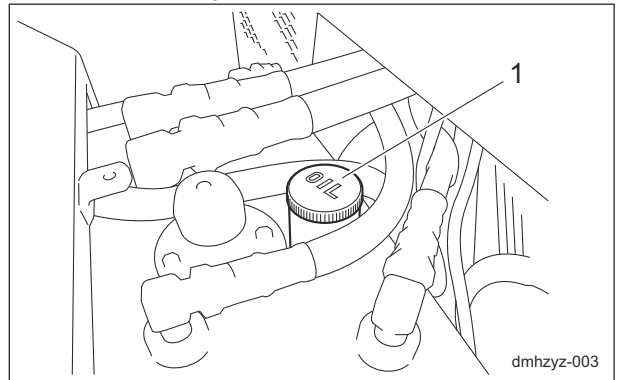

Replacement of Hydraulic Oil_002

1	Tank cap
---	----------

3. Tighten the tank cap securely.
4. Start the engine, and then repeat the steps below a few times.
 - Raise and lower the brush frame.
 - Raise and lower the bucket.
5. Lower the brush frame and the bucket on a level surface and maintain that position, and then check to see if the oil level is at the middle of the oil gauge. If the hydraulic oil level is low, supply oil again until it reaches the specified level.
6. Check underneath the machine for oil leakage.

Maintenance

Replacement of Hydraulic Oil Filter

■ Replacement of Hydraulic Oil Line Filter

Caution

Be careful with hot oil, which could cause burns if it contacts your skin.

Important

When replacing the hydraulic oil filter, be sure to drain the oil into a container and discard it in accordance with local laws and regulations.

Important

If the hydraulic oil emulsifies or if it becomes even slightly less transparent, change the oil immediately.

Important

Use hydraulic oil whose specification meets the requirements.

1. Remove the cover on the right side of the seat.
2. On a level surface, lower the brush frame and the bucket, and then stop the engine.
3. Loosen the filter case and remove it.

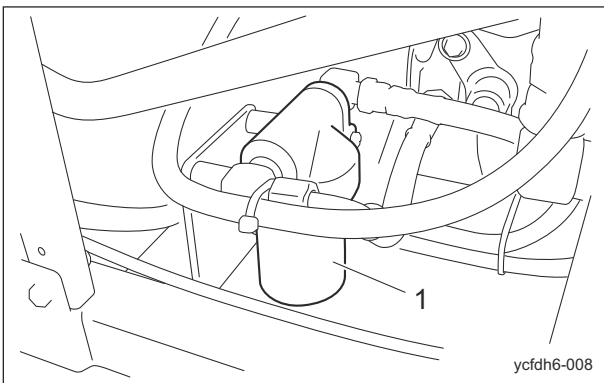

Replacement of Hydraulic Oil Line Filter_001

1	Filter case
---	-------------

4. Remove the old filter cartridge.

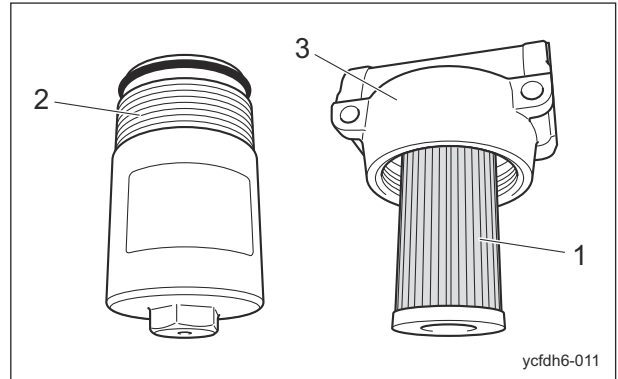

Replacement of Hydraulic Oil Line Filter_002

1	Filter cartridge
2	Filter case
3	Body

5. Lightly coat the O-ring of the new filter cartridge with hydraulic oil, and then install the cartridge.

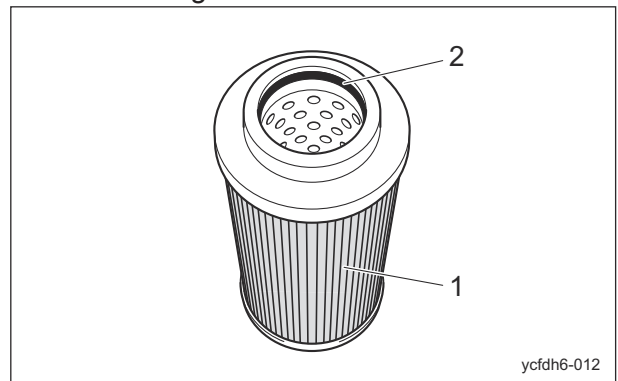

Replacement of Hydraulic Oil Line Filter_003

1	Filter cartridge
2	O-ring

6. Clean the inside of the filter case.
7. Make sure that there is no damage to the O-ring of the filter case, and then lightly coat the O-ring with hydraulic oil.

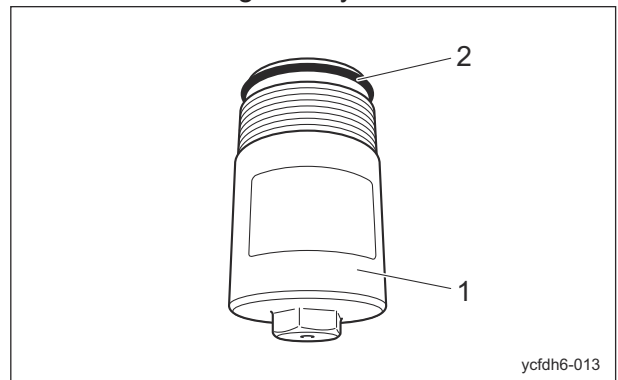

Replacement of Hydraulic Oil Line Filter_004

1	Filter case
2	O-ring

8. Install the filter case onto the body, firmly hand-tighten it, and then tighten it to 25 to 35 N·m (254.93 - 356.90 kgf-cm).

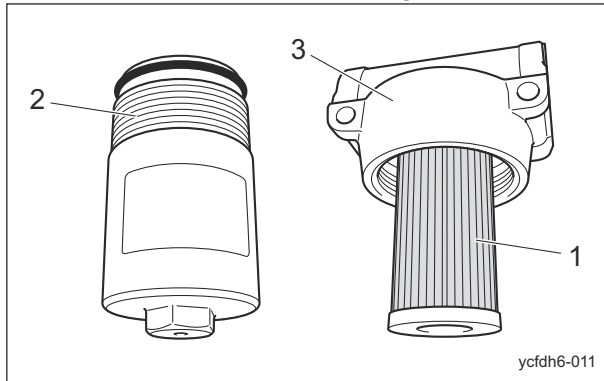

Replacement of Hydraulic Oil Line Filter_005

1	Filter cartridge
2	Filter case
3	Body

9. Supply hydraulic oil until it reaches the specified level.
"Supply of Hydraulic Oil" (Page 6-6)
10. Start the engine and stop it after hydraulic oil warmed.
11. Check underneath the machine for hydraulic oil leakage.
12. Install the cover on the right side of the seat.

■Replacement of Hydraulic Oil Suction Filter

Caution

Be careful with hot oil, which could cause burns if it contacts your skin.

Important

When replacing the hydraulic oil filter, be sure to drain the oil into a container and discard it in accordance with local laws and regulations.

Important

If the hydraulic oil emulsifies or if it becomes even slightly less transparent, change the oil immediately.

Important

Use hydraulic oil whose specification meets the requirements.

1. Remove the cover on the right side of the seat.
2. On a level surface, lower the brush frame and the bucket, and then stop the engine.
3. Remove the old filter cartridge.
4. Lightly coat the packing of the new filter cartridge with hydraulic oil, and then install the cartridge.
5. Firmly tighten the filter cartridge by hand so that the packing contacts the mounting surface.
Then, tighten it an additional 1/2 turn.

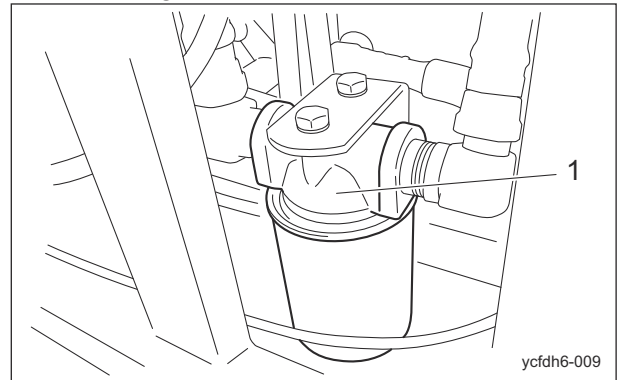

Replacement of Hydraulic Oil Suction Filter_001

1	Cartridge filter
---	------------------

6. Supply hydraulic oil until it reaches the specified level.
"Supply of Hydraulic Oil" (Page 6-6)
7. Start the engine, and then after the hydraulic oil has warmed up, stop the engine.
8. Check underneath the machine for hydraulic oil leakage.
9. Install the cover on the right side of the seat.

Maintenance

Replacement of Air Breather Element

⚠ Caution

Be careful with hot oil, which could cause burns if it contacts your skin.

1. Stop the engine on a flat surface.
2. Open the front cover.
3. Remove the bolt, then the cover.

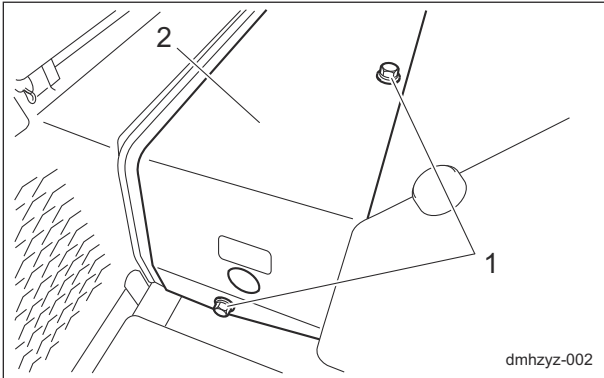

Replacement of Air Breather Element_001

1	Bolt
2	Cover

4. Loosen the air breather screw and remove the seal washer.

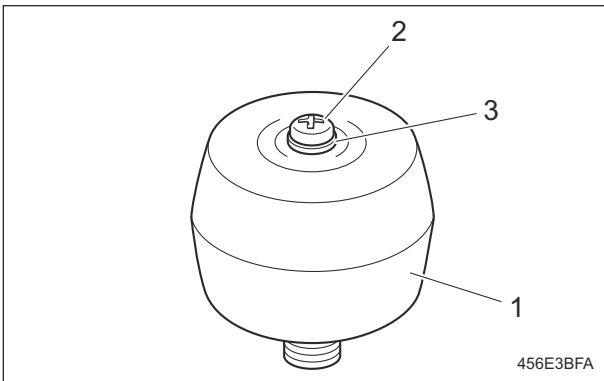

Replacement of Air Breather Element_002

1	Air breather
2	Screw
3	Seal washer

5. Remove the top cover of the air breather.

6. Remove the old element.

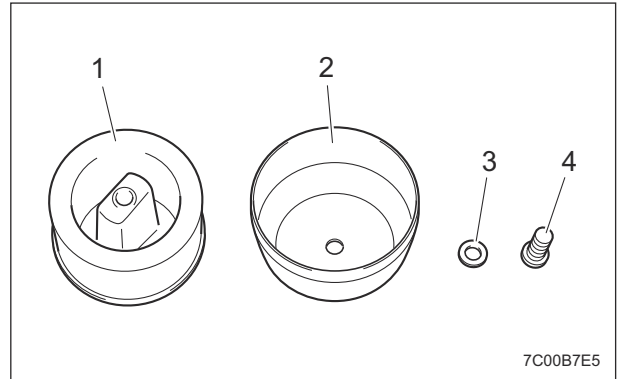

Replacement of Air Breather Element_003

1	Element
2	Top cover
3	Seal washer
4	Screw

7. Install the new element.

Important

If the seal washer is damaged, replace it with a new one.

8. Install the top cover of the air breather.
9. Install the seal washer and tighten the screw.
10. Install the cover and tighten the bolt.
11. Close the front cover.

Replacement of Tires

■ Replacement of Front Tires

1. Removing front tires

Follow the steps below to remove the front tires:

- [1] Loosen the bolts.

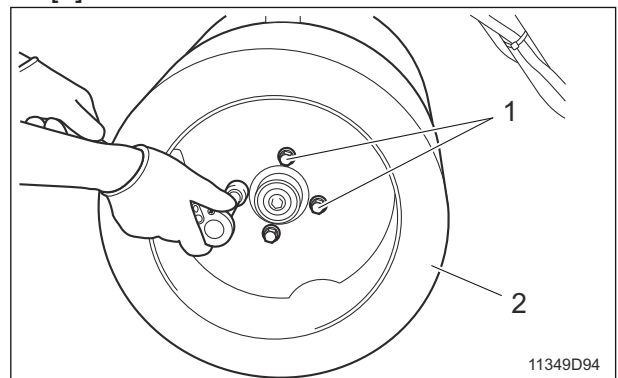

Replacement of Front Tires_001

1	Bolt
2	Front tire

[2] Securely place the jacks beneath the jack-up points of the left/right front brush frame mount areas, and then raise them until the tires lift off the ground.
"Jack-up Points" (Page 6-2)

[3] Remove the bolts.

[4] Remove the tire from the wheel mounting seat.

2. Installing front tire

Important

Tighten the bolts in the tightening order (diagonally).

Important

Tighten the wheel mounting bolts on the specified torque by using a torque wrench.

For installing the front tires, reverse the removing procedure.

■ Replacement of Rear Tires

1. Removing rear tires

Follow the steps below to remove the rear tires:

[1] Loosen the bolts.

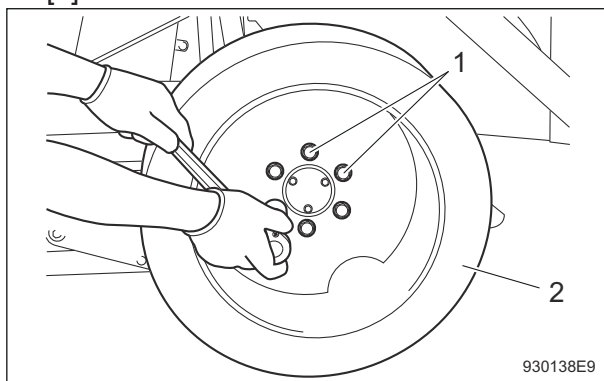

Replacement of Rear Tires_001

1	Bolt
2	Rear tire

[2] Securely place the jacks beneath the jack-up points of the rear left/right frame areas, and then raise them until the tires lift off the ground.
"Jack-up Points" (Page 6-2)

[3] Remove the bolts.

[4] Remove the tire from the wheel mounting seat.

2. Installing rear tire

Important

Tighten the bolts in the tightening order (diagonally).

Important

Tighten the wheel mounting bolts on the specified torque by using a torque wrench.

For installing the rear tires, reverse the removing procedure.

Replacement of Brushes

Caution

During maintenance service, raise the empty bucket.

Important

If the brush operation height is inadequate, cores will not be properly collected.

Important

If the left and right sides of the brushes are at different heights, the cores will not be uniformly collected, and the brushes will wear unevenly.

Important

Replace all brushes. Otherwise the weight will become unbalanced and vibration may occur.

If the clearance between the rotary brush tips and the brush frame cannot be adjusted to approximately 5 mm (0.20 in) due to brush wear, replace the brushes.

1. Move the machine to level ground.
2. Apply the parking brake.
3. Raise the bucket to its highest position.
4. Stop the engine.

Warning

To keep the position of raised bucket, be sure to lock it with the cylinder lock.

5. Lock the bucket with the cylinder lock.
6. Remove the brush cover.

Maintenance

7. Remove the bolts securing the brush.

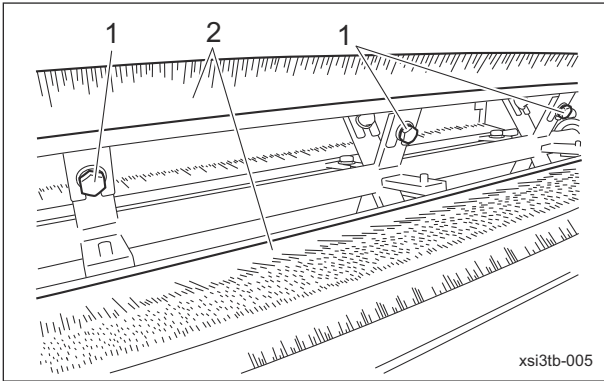

Change of Brushes_001

1	Bolt
2	Brush

8. Remove the rotary brush.

9. Install a new rotary brush.

Important

Evenly install the brush.

10. Adjust the brush so that there is a clearance of approximately 5 mm (0.20 in) between its tip and the brush frame, and then temporarily tighten the bolts.

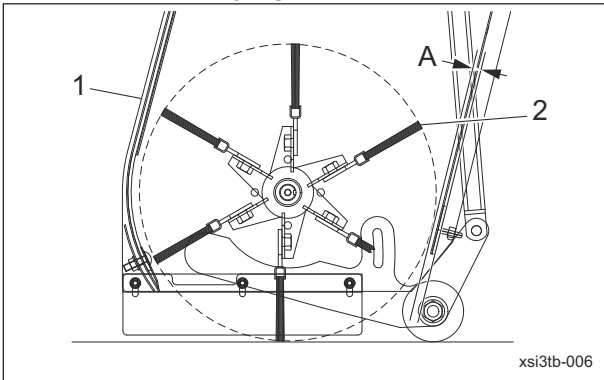

Change of Brushes_002

1	Brush frame
2	Tip of rotary brush
A	5 mm (0.20 in)

11. Slowly rotate the rotary brushes by hand, and then follow the same steps to adjust the remaining brushes and temporarily tighten the bolts.

12. Slowly rotate the rotary brushes by hand, check the clearance again and tighten the bolts so that all the clearances between the brush tips and the brush frame will be the same.

13. After making adjustments of all the brushes and tightening the bolts, tighten all bolts firmly.

14. Install the brush cover.

15. Start the engine, rotate the brushes, and then check that there is no contact between or vibration in the brushes and brush frame.

Replacement of Rotary Plates

Caution

During maintenance service, raise the empty bucket.

Important

If the rotary plates are worn, cores will not be properly collected.

Important

Replace all rotary plates. Otherwise the weight will become unbalanced and vibration may occur.

If wear of the rotary plates exceeds 5 mm (0.20 in) or if they are deformed or cracked, replace the rotary plates.

1. Move the machine to level ground.
2. Apply the parking brake.
3. Raise the bucket to its highest position.
4. Stop the engine.

Warning

To keep the position of raised bucket, be sure to lock it with the cylinder lock.

5. Lock the bucket with the cylinder lock.

6. Remove the brush cover.

7. Remove the bolts securing the rotary plate.

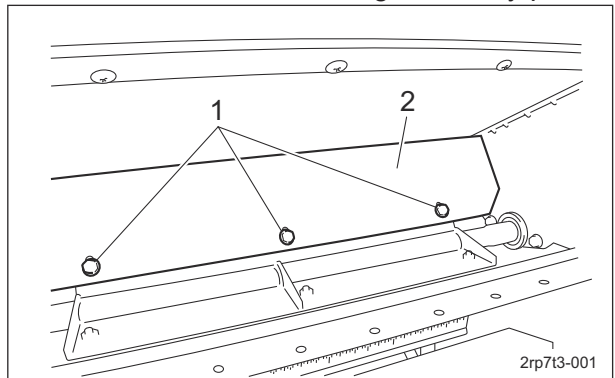

Replacement of Rotary Plates_001

1	Bolt
2	Rotary plate

8. Remove the rotary plate.
9. Install a new rotary plate.

Important

Evenly install the rotary plate.

10. Adjust the rotary plate so that there is a clearance of approximately 5 mm (0.20 in) between it and the brush frame, and then temporarily tighten the bolts.

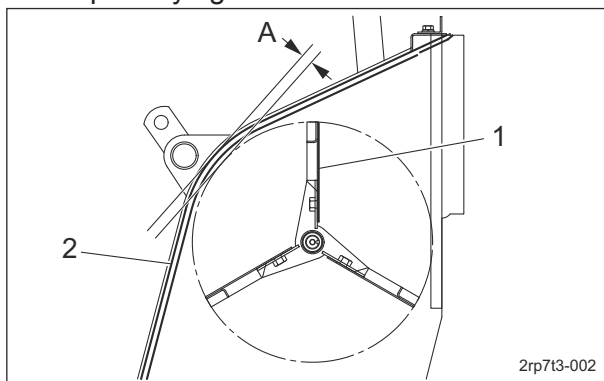

Replacement of Rotary Plates_002

1	Rotary Plates
2	Brush frame
A	5 mm (0.20 in)

11. Slowly rotate the rotary plates by hand, and then follow the same steps to adjust the remaining rotary plates and temporarily tighten the bolts.
12. Slowly rotate the rotary plates by hand, check the clearance again and tighten the bolts so that all the clearances between the rotary plates and the brush frame will be the same.
13. After making adjustments of all the rotary plates and tightening the bolts, tighten all bolts firmly.
14. Install the brush cover.
15. Start the engine, rotate the rotary plates, and then check that there is no contact between or vibration in the rotary plates and brush frame.

Replacement of Belts

Warning

Be sure to stop the engine before replacing a belt.

Warning

If you have removed covers, etc., be sure to securely install them in their original positions. If covers, etc., remain removed, the operator or the mechanic may come in contact with rotating parts or belts, or foreign objects may fly off, possibly resulting in injuries.

■ Replacement of Pump Drive Belt

1. Move the machine to a level ground.
2. Apply the parking brake.
3. Lower the brush frame and the bucket.
4. Stop the engine.
5. Open the underseat cover.
6. Loosen the nut.
7. Loosen the high nut.
8. Remove the old belt.

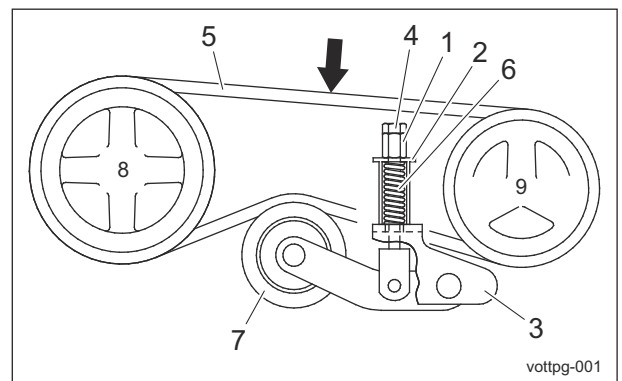

Replacement of Pump Drive Belt_001

1	High nut
2	Spring cover
3	Tension fulcrum fitting
4	Nut
5	Belt
6	Spring
7	Tension pulley
8	Engine pulley
9	Pump pulley

9. Install the new belt.

Maintenance

10. Check the belt tension.
The criterion for the belt tension is that the belt slacks approximately 10 mm (0.39 in) when you apply a force of 98 N (10 kgf) with your finger to the belt at the middle point between the pulleys (arrow in the diagram).
11. Close the underseat cover.

■ Replacement of Brush Belt

1. Move the machine to a level ground.
2. Apply the parking brake.
3. Lower the brush frame and the bucket.
4. Stop the engine.
5. Remove the bolts.
6. Remove the belt cover.

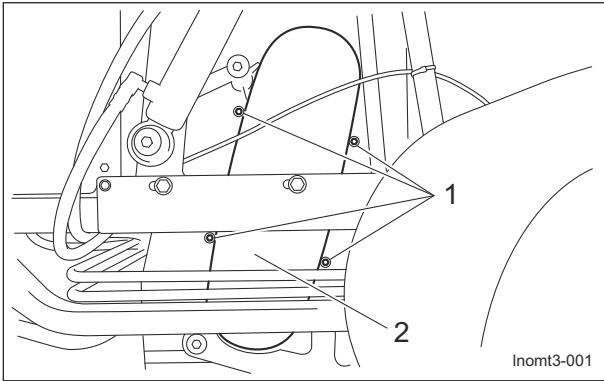

Replacement of Brush Belt_001

1	Bolt
2	Belt cover

7. Loosen the bolt.
8. Loosen the nut.
9. Remove the old belt.

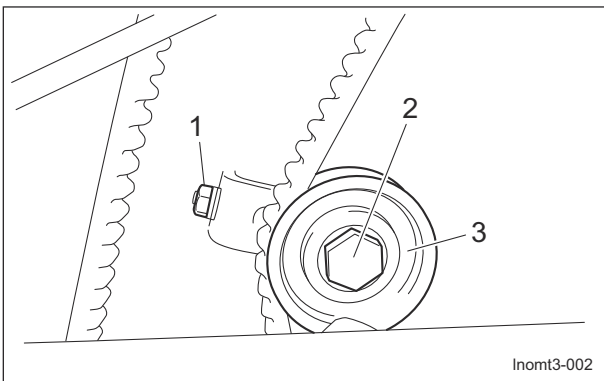

Replacement of Brush Belt_002

1	Nut
2	Bolt
3	Tension pulley

10. Install the new belt.

11. Check the belt tension.
The criterion for the belt tension is that the belt slacks approximately 10 mm (0.39 in) when you apply a force of 98 N (10 kgf) with your finger to the belt at the middle point.
12. Install the belt cover.

Storage

Long-Term Storage

Follow the instructions below for long-term storage of the machine.

1. Cleaning
 - Remove dirt, grass clippings, oil stains etc. completely from the main vehicle and engine.
2. Replacing oil
 - Inspect and replace the engine oil, hydraulic oil and element.
3. Greasing and lubricating
 - Supply oil and apply grease to appropriate parts.
4. Battery
 - Remove the negative battery wire.
5. Fuel
 - Remove the fuel from the fuel tank.
6. Tire pneumatic pressure
 - Set the tire air pressure slightly higher than normal, and then place the machine on a board to avoid humidity.
7. Storage location
 - Cover the machine and store it in a dry place where it will not be exposed to rain.

Precautions for Repair Page 7-2

Adjustment and Replacement Page 7-2

Adjustment of Brake Page 7-2

Adjustment of The Neutral Position
of The Piston Pump Page 7-3

Replacement of Fuse Page 7-4

TowingPage 7-5

Towing The Machine in An
EmergencyPage 7-5

Repair

Precautions for Repair

Warning

The chapter "Repair" in this manual describes practical measures which should be performed by a mechanic with expertise. The owner should instruct the mechanic with expertise to perform repair service for this machine.

Caution

First, learn well the operations you plan to perform.

Important

Use tools appropriate for each operation.

Important

Use Baroness genuine parts for replacement and accessories. Our product warranty may be void if you use non-genuine parts for replacement or accessories.

Adjustment and Replacement

Adjustment of Brake

Caution

If the brake wire is cut, the machine will be unable to stop. If the brake wire is cracked or damaged, replace it with a new one immediately. If the brake is not sufficiently effective, adjust the brake wire.

Important

Adjust to reduce the play in the brake lever as much as possible so that the brake does not drag when the lever is released.

1. Adjust the brake by tightening the brake wire adjustment bolt.
 - If there is too much play in the brake lever, the braking power is reduced and the brake pedal feel is light.

- If there is too little play in the brake lever, the braking power is increased and the brake pedal feel is heavy.

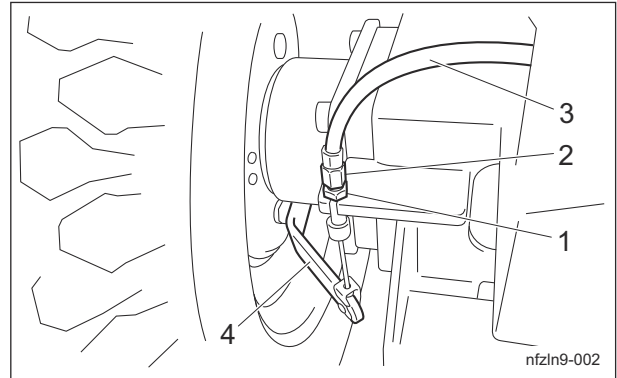

Adjustment of Brake_001

1	Lock nut
2	Adjustment bolt
3	Brake wire
4	Brake lever

2. Start the engine and drive to check the following.
 - Make sure that heat is not generated in the brake area.
 - Make sure that the left and right brakes are equally effective.

Caution

It may result in an unexpected accident if the left and right brakes are not equally effective.

3. If the left and right brakes are not equally effective, make fine adjustments with the adjustment bolt on the brake wire.

Break-In of Brakes

If the brake shoes or brake pads are worn, replace them with new ones. Immediately after replacement, drive to break in the brakes if the effectiveness of the brakes is low. While driving, lightly operate the brakes to break in the contact areas.

Adjustment of The Neutral Position of The Piston Pump

Warning

When adjusting the neutral position, exercise care so that the hand does not get entangled in the rotating parts.

Caution

Make sure not to touch rotating tires.

Caution

When adjusting the neutral position, pay close attention to abrupt start of the machine. Place the jacks beneath the jack-up points, and then lift the machine until all the tires get off the ground.

If the machine moves forward or backward while the traveling pedals are released, they are not set to the neutral position.

Follow the steps below to make adjustments.

1. Stop the engine.
2. Remove the cotter pin and washer from the pedal end, and then disconnect the end of the push-pull cable.

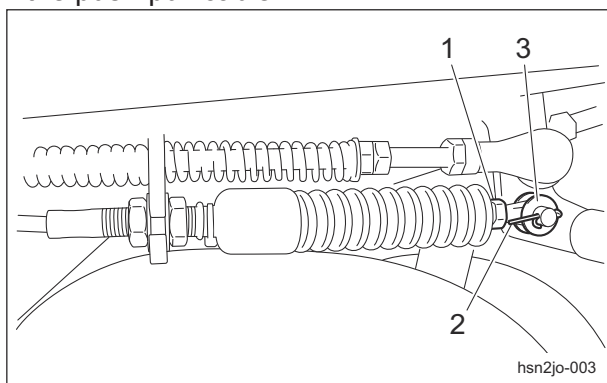

Adjustment of The Neutral Position of The Piston Pump_001

1	Push-pull cable
2	Cotter pin
3	Washer

3. Place the jacks beneath the jack-up points, and then lift the machine off the ground. Use stable jack stands, and raise the machine until the tires lift off the ground. "Jack-up Points" (Page 6-2)

4. Start the engine, and rev it up to the maximum rpm.
5. Loosen the nut on the camshaft.

6. Slowly rotate the camshaft until the rear wheels stop, and then lock the camshaft with the nut at the stopped position.

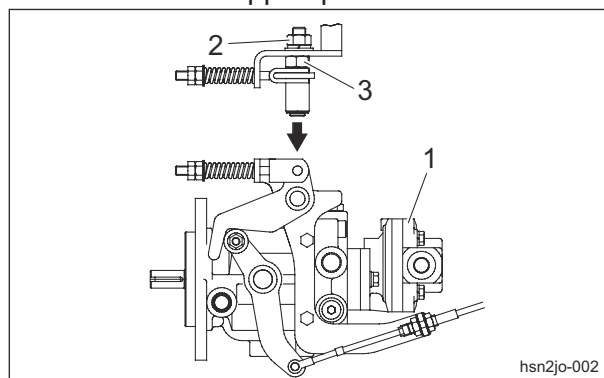

Adjustment of The Neutral Position of The Piston Pump_002

1	Piston pump
2	Nut
3	Camshaft

7. Loosen the adjuster nuts.

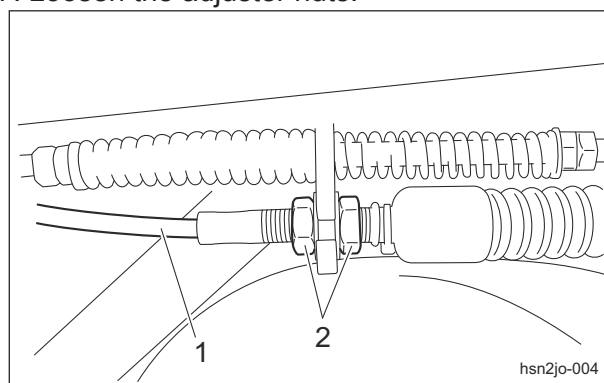

Adjustment of The Neutral Position of The Piston Pump_003

1	Push-pull cable
2	Adjuster nuts

8. Adjust the nuts until the end of the push-pull cable of the pedal side attaches to the pedal mount, and then tighten the adjuster nuts.

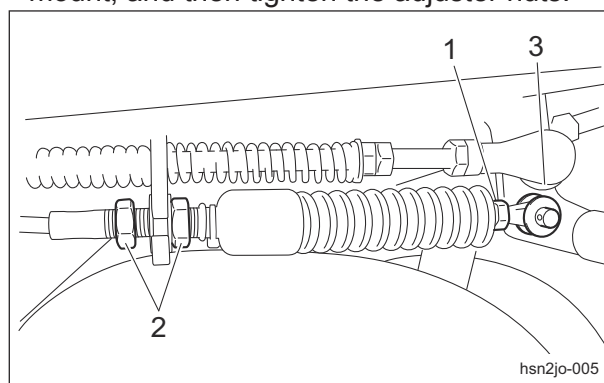

Adjustment of The Neutral Position of The Piston Pump_004

Repair

1	Push-pull cable
2	Adjuster nuts
3	Pedal mount

9. Insert the push-pull cable, and then install the washer and cotter pin.

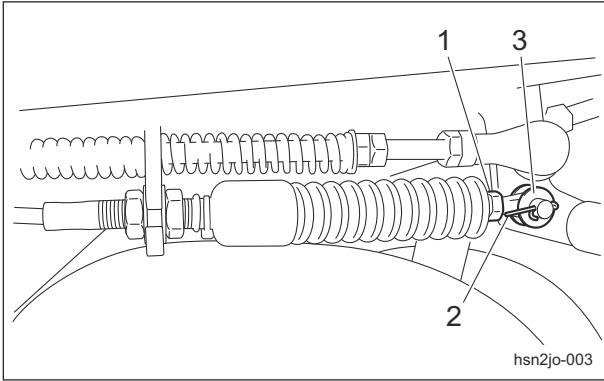

Adjustment of The Neutral Position of The Piston Pump_005

1	Push-pull cable
2	Cotter pin
3	Washer

Fuses

Fuses are located in the lower right corner behind the front cover and consist of the main harness fuse for the entire circuit. It is a mini blade fuse 20 A.

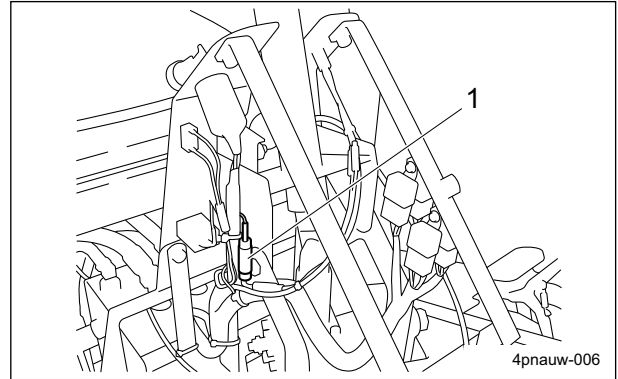

Fuses_001

1	Main harness fuse
---	-------------------

Replacement of Fuse

Important

When performing maintenance on the electrical system, be sure to remove the negative battery wire.

Important

If a fuse blows, a short may have occurred within the electrical circuit. Check for the cause, such as faulty terminal connections, damaged wiring or terminals, or incorrect wiring.

Important

For fuse replacement, clean the fuse mounting area with use of compressed air before mounting the fuse.

Towing

Towing The Machine in An Emergency

If the machine does not travel due to engine trouble, etc., you can move it in the following ways:

- Pushing by hand
- Towing (See the following instruction.)

⚠ Caution

Unless you plan to tow the machine, raise the bolts so they do not contact the unload valve operating pins, and then tighten the lock nuts firmly.

⚠ Caution

Before restarting the engine, be sure to close the bypass.

Important

When towing the machine, comply with the following limits.

Obey the speed and the time restrictions to prevent damaging the pump or motor.

- Speed: Do not tow at a speed exceeding 3.0 km/m.
- Time: Do not tow for more than 3 minutes, the allowance of accumulated towing time. After a lapse of the allowed time for towing, the engine starting is required to circulate the hydraulic oil in the hydraulic circuit. Therefore, the machine should not be towed until the repair is completed and the engine is restarted.

1. Stop the engine.
"Procedure to Stop Engine" (Page 5-13)
2. Apply the parking brake.
3. Chock the wheels.

4. Secure the rope to the front part of the frame.

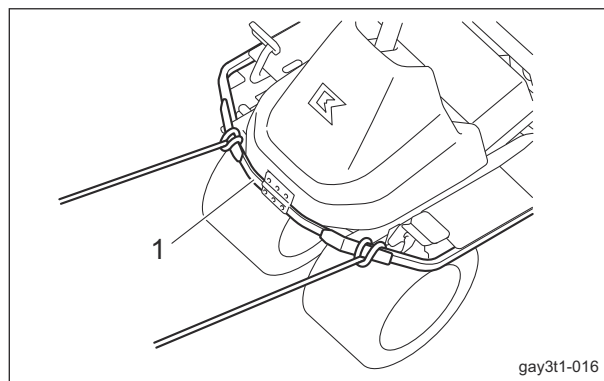

Towing The Machine in An Emergency_001

1	Frame
---	-------

5. Open the underseat cover.
"Procedure to Open/Close Underseat Cover" (Page 5-2)
6. Loosen the lock nut.

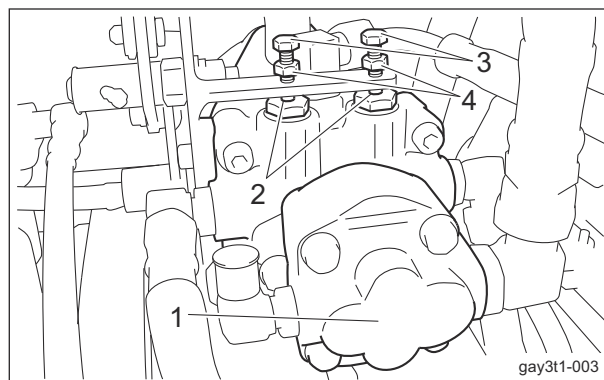

Towing The Machine in An Emergency_002

1	Piston pump
2	Unload valve operating pin
3	Bolt
4	Lock nut

Repair

Important

When compressing the unload valve operating pins, be careful not to overtighten the bolts. Otherwise, the unload valve operating pins will be damaged.

Important

For unloading, be sure to open the two unload valves. Opening only one unload valve will cause the hydraulic system to malfunction.

7. Open the bypass.

- [1] Loosen the lock nut on each of the two unload valves.
- [2] Tighten the two bolts and push in the unload valve operating pins.
- [3] Tighten the lock nut on each of the two unload valves.

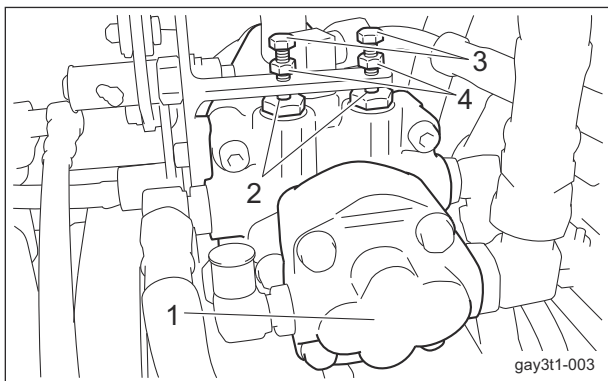

Towing The Machine in An Emergency_003

1	Piston pump
2	Unload valve operating pin
3	Bolt
4	Lock nut

8. Close the underseat cover.

9. Remove the wheel stoppers.

10. Release the parking brake.

Warning

While towing, always keep your foot on the brake pedal and make sure you can depress the brake pedal at any time to stop.

11. Tow the machine slowly.

Appended Table

Tightening TorquesPage 8-2
 Standard Tightening TorquesPage 8-2
 Principal Tightening Torques Page 8-5

Daily Check List Page 8-6

Maintenance Schedule Page 8-7

List of Adjusted Values Page 8-8

Appended Table

Tightening Torques

Important

Refer to the Tightening Torque table.
Note that the Baroness product warranty may not apply to defects caused by incorrect or overtorque tightening, etc.

Standard Tightening Torques

Bolts and Nuts



Important

A number of bolts are used in each part of this machine.
Be sure to re-tighten the bolts and nuts, because they may be loosened at the earlier stage of the use.

- As to the bolts and nuts without any special instruction, tighten them in appropriate tightening torque with proper tool.
Too much tightening may cause the looseness or damage of the screw.
- The strength of tightening is determined by types of screws, strength, the friction of thread face or base face and others.
The table below is for the galvanized or parkerized bolts.
In case that the strength of internal thread is weak, it is not applied.
- Do not use rusty or sand attached "screw."
Otherwise, it may cause insufficient tightening even if you apply the specified tightening torque.
The friction of the screw face becomes higher and the tightening torque is canceled out by the friction, therefore sufficient tightening cannot be applied.
- If "screw" is wet by water or oil, do not tighten it with normal tightening torque.
If the screw is wet, the torque coefficient will get smaller and it may result in too much tightening.
Too much tightening may cause looseness by the screw stretched or result in damage.
- Do not use a bolt experienced too much burden.
- Using the impact wrench requires the skill.
Do exercise as much as possible for steady tightening.

Appended Table

Nominal diameter	General bolt		
	Strength classification 4.8		
	 tib3yb-001		
	N-m	kgf-cm	lb-in
M5	3 - 5	30.59 - 50.99	26.55 - 44.26
M6	7 - 9	71.38 - 91.77	61.96 - 79.66
M8	14 - 19	142.76 - 193.74	123.91 - 168.17
M10	29 - 38	295.71 - 387.49	256.68 - 336.34
M12	52 - 67	530.24 - 683.20	460.25 - 593.02
M14	70 - 94	713.79 - 958.52	619.57 - 831.99
M16	88 - 112	897.34 - 1142.06	778.89 - 991.31
M18	116 - 144	1,182.85 - 1,468.37	1,026.72 - 1,274.54
M20	147 - 183	1,498.96 - 1,866.05	1,301.10 - 1,619.73
M22	295	3,008.12	2,611.05
M24	370	3,772.89	3,274.87
M27	550	5,608.35	4,868.05
M30	740	7,545.78	6,549.74

Nominal diameter	Heat-treated bolt					
	Strength classification 8.8			Strength classification 10.9		
	 tib3yb-002			 tib3yb-003		
	N-m	kgf-cm	lb-in	N-m	kgf-cm	lb-in
M5	5 - 7	50.99 - 71.38	44.26 - 61.96	7 - 10	71.38 - 101.97	61.96 - 88.51
M6	8 - 11	81.58 - 112.17	70.81 - 97.36	14 - 18	142.76 - 183.55	123.91 - 159.32
M8	23 - 29	234.53 - 295.71	203.57 - 256.68	28 - 38	285.52 - 387.49	247.83 - 336.34
M10	45 - 57	458.87 - 581.23	398.30 - 504.51	58 - 76	591.43 - 774.97	513.36 - 672.68
M12	67 - 85	683.20 - 866.75	593.02 - 752.34	104 - 134	1,060.49 - 1,366.40	920.50 - 1186.03
M14	106 - 134	1,080.88 - 1,366.40	938.21 - 1,186.03	140 - 188	1,427.58 - 1,917.04	1,239.14 - 1,663.99
M16	152 - 188	1,549.94 - 1,917.04	1,345.35 - 1,663.99	210 - 260	2,141.37 - 2,651.22	1,858.71 - 2,301.26
M18	200 - 240	2,039.40 - 2,447.28	1,770.20 - 2,124.24	280 - 340	2,855.16 - 3,466.98	2,478.28 - 3,009.34
M20	245 - 295	2,498.27 - 3,008.12	2,168.50 - 2,611.05	370 - 450	3,772.89 - 4,588.65	3,274.87 - 3,982.95
M22	-	-	-	530	5,404.41	4,691.03
M24	-	-	-	670	6,831.99	5,930.17
M27	-	-	-	1,000	10,197.00	8,851.00
M30	-	-	-	1,340	13,663.98	11,860.34

Note:
The same values are applied to "fine screw thread."

Appended Table

Hydraulic Hose

The tightening torques for union joints and union adaptors with parallel pipe threads (G, PF) are shown in the table below.

A union joint or adaptor will not become loose or leak as long as it is tightened by the specified torque.

If fluid leaks from the sealed portion, do not attempt to tighten the union joint or adaptor forcibly.

Examine whether any foreign matter or scratches are present on the seat surface.

Tightening a union joint or adaptor forcibly could damage the connection of the joints.

When tightening a union joint or adaptor, use a torque wrench where possible and firmly tighten it by an appropriate torque.

Nominal diameter of the hose size	Nominal diameter of the parallel pipe threads (G, PF)	Tightening torque		
		N-m	kgf-cm	lb-in
6	1/4	25	254.93	221.28
9	3/8	50	509.85	442.55
12	1/2	60	611.82	531.06
15	3/4	120	1,223.64	1,062.12
19	3/4	120	1,223.64	1,062.12
25	1	140	1,427.58	1,239.14
32	1-1/4	170	1,733.49	1,504.67
38	1-1/2	210	2,141.37	1,858.71
50	2	250	2,549.25	2,212.75

Fittings with Parallel Threads (O-Ring Seal Type)

The tightening torques for fittings with parallel threads (O-ring seal method) are shown in the table below.

Tightening the fitting forcibly with a spanner or other such tool to secure it to a set position could damage the fitting, its washers, and other parts.

When tightening an adjustable elbow, use a torque wrench where possible and firmly tighten it by an appropriate torque.

Nominal diameter of thread	Tightening torque		
	N-m	kgf-cm	lb-in.
1/4	34.32 - 49.03	349.96 – 499.96	303.77 – 433.96
3/8	68.65 - 78.45	700.02 – 799.95	607.62 – 694.36
1/2	98.07 - 117.68	1,000.02 – 1,199.98	868.02 – 1,041.59
3/4	147.10 - 176.52	1,499.98 – 1,799.97	1,301.98 – 1,562.38
1	245.17 - 274.59	2,500.00 – 2,799.99	2,170.00 – 2,430.40
1-1/4	294.20	2,999.96	2,603.96
1-1/2	294.20	2,999.96	2,603.96
2	392.27	3,999.98	3,471.98

Appended Table

Principal Tightening Torques

Tightening Torque by Model

FS900

Tighten the following bolts and nuts at the torque specified in the table.

For thread locking adhesive, apply a middle strength thread locker (ThreeBond 1322 or equivalent anaerobic sealant).

Location		Code	Part name	Tightening torque			Thread locking adhesive
				N-m	kgf-cm	lb-in	
Front wheel	Front wheel housing	K0011120252	Bolt, heat-treated M12-25P1.5	67 - 85	683.20 - 866.75	593.02 - 752.34	-
	Wheel	K0010100302	Bolt, heat-treated M10-30	58 - 76	591.43 - 774.97	513.36 - 672.68	-
Rear wheel	Wheel	K0011120302	Bolt, heat-treated M12-30P1.5	67 - 85	683.20 - 866.75	593.02 - 752.34	-
	Wheel mounting base	K0160000492	24 special nut P1.5	180 - 200	1,835.46 - 2,039.40	1,593.18 - 1,770.20	○
Front wheel arm		K0010100252	Bolt, heat-treated M10-25	45 - 76	458.87 - 774.97	398.30 - 672.68	-
Bucket mounting frame		K0010120602	Bolt, heat-treated M12-60	67 - 85	683.20 - 866.75	593.02 - 752.34	-
Orbit motor		YT40243M2	Connector, port RC3/8	45 - 50	458.87 - 509.86	398.30 - 442.55	-
Proximity switch NO V-out		K0100050002	NUT, M5	2.5	25.49	22.13	-
Tie rod end	- (K1610000020)	Slotted nut (END ASSY, TIE-ROD MALE (RH))	52 - 67	530.24 - 683.20	460.25 - 593.02	-	
	- (K1611000020)	Slotted nut (END ASSY, TIE-ROD LEFT-HANDED MALE (LH))	52 - 67	530.24 - 683.20	460.25 - 593.02	-	
Battery terminal	K3612000090	+ Battery terminal 4013-39-1	9	91.77	79.66	-	
	K3612000100	- Battery terminal 4013-39-2	9	91.77	79.66	-	

Appended Table

Appended Table

Daily Check List

- . . . Inspect, adjust, supply, clean (first time)
- . . . Inspect, adjust, supply, clean
- ▲ . . . Replace (first time)
- △ . . . Replace

Maintenance Item		Before Work	After Work	Remarks
Engine	*1	Check engine oil	○	
		Check fuel	○	
		Check air cleaner	○	
		Check fuel filter	○	
		Check fuel strainer	○	
		Check engine area	○	
		Check bolts and nuts	○	
	*1	Clean engine area		○
Main vehicle		Check hydraulic oil	○	
		Check tire	○	
	*2	Check battery	○	
		Check outriggers	○	
		Check cover	○	
		Check brake pedal	○	
		Check parking brake	○	
		Check traveling pedal	○	
		Check wire	○	
		Check liquid leakage	○	
		Clean machine exterior	○	
		Check bolts and nuts	○	
		Check instruments	○	
		Check safety device	○	
		Check steering wheel	○	
		Check lighting	○	
		Check bucket	○	
		Check bucket lid	○	
		Check rotary plate	○	
		Check brush	○	
		Check apron	○	
		Check roller	○	
		Adjust brush operation height	○	
	Clean machine exterior		○	
	Clean sweeper section		○	
	Clean bucket interior		○	

· *1: Refer to the Engine's Owner's Manual.
 · *2: Refer to the Battery's Owner's Manual.

Appended Table

Maintenance Schedule

FS900

- . . . Inspect, adjust, supply, clean (first time)
- . . . Inspect, adjust, supply, clean
- ▲ . . . Replace (first time)
- △ . . . Replace

Maintenance Item		Before Work	Every 50 hrs.	Every 100 hrs.	Every 250 hrs.	Every 400 hrs.	Every 500 hrs.	Every 3 months	Every year	Every 2 years	Every 4 years	When Required	Remarks	
Engine	*1	Clean air cleaner element		○									Air cleaner should be cleaned more often in dusty conditions than in normal conditions	
		Clean sediment cup		○										
	*1	Check muffler		○										
	*1	Check valve clearance			○									
	*1	Replace engine oil	▲	△										
	*1	Replace engine oil filter	▲	△										
	*1	Replace spark plug		△										
	*1	Replace air cleaner element				△			△					Check every 400 hours or every year whichever comes earlier
	*1	Replace fuel filter				△			△					Check every 400 hours or every year whichever comes earlier
	*1	Check fuel hoses and clamps								△				
Main vehicle		Check hydraulic hose (Moving part)	○											
		Check belt	○											
		Check electrical wiring		●	○									
		Check wheel mounting bolts		●	○									
		Check hydraulic hose (Fixed part)			○				○					Check every 100 hours or every month whichever comes earlier
		Grease and Lubricate		○				○						Maintenance schedules differ according to greasing points
		Replace hydraulic oil			▲		△							
		Replace hydraulic oil suction filter			▲		△							
		Replace hydraulic oil line filter			▲		△							
		Replace air breather element			▲									
	*2	Replace battery									△			
		Replace hydraulic hoses (Moving part)									△			

Appended Table

Appended Table

Maintenance Item		Before Work	Every 50 hrs.	Every 100 hrs.	Every 250 hrs.	Every 400 hrs.	Every 500 hrs.	Every 3 months	Every year	Every 2 years	Every 4 years	When Required	Remarks
Main vehicle	Replace hydraulic hoses (Fixed part)										△		
	Replace Belt											△	
	Replace brake wire											△	
	Replace traveling cable											△	
	Replace throttle wire											△	
	Replace choke wire											△	
	Replace brake shoe											△	

- *1: Refer to the Engine's Owner's Manual.
- *2: Refer to the Battery's Owner's Manual.
- The values for consumables are not guaranteed.

List of Adjusted Values

Pump drive belt	Approx.10 mm (0.39 in)	Belt slack when belt pressed with 98 N (10 kgf) at the middle point between pulleys.
Brush belt	Approx.10 mm (0.39 in)	Belt slack when belt pressed with 98 N (10 kgf) at the middle point between pulleys.
Brush	5 mm (0.20 in)	Clearance between the rotary brush tip and the brush frame.
Rotary plate	5 mm (0.20 in)	Clearance between the rotary plate and the brush frame.

Records

Daily Check Records Page 9-2

Maintenance RecordsPage 9-5



Records

Records

Daily Check Records

FS900

Use this table freely for your records of the daily check.

Model								Serial Number			
Items											
Engine	Check engine oil										
	Check fuel										
	Check air cleaner										
	Check fuel filter										
	Check fuel strainer										
	Check engine area										
	Check bolts and nuts										
	Clean engine area										
Main vehicle	Check hydraulic oil										
	Check tire										
	Check battery										
	Check outriggers										

Records

Items											
Main vehicle	Check cover										
	Check brake pedal										
	Check parking brake										
	Check traveling pedal										
	Check wire										
	Check liquid leakage										
	Clean machine exterior										
	Check bolts and nuts										
	Check instruments										
	Check safety device										
	Check steering wheel										
	Check lighting										
	Check bucket										
	Check bucket lid										

Records

Records

Items											
Main vehicle	Check rotary plate										
	Check brush										
	Check apron										
	Check roller										
	Adjust brush operation height										
	Clean machine exterior										
	Clean sweeper section										
	Clean bucket interior										

Maintenance Records

FS900
 Use this table freely for your records of the maintenance.

Model		Serial Number								
Items										
Engine	Clean air cleaner element									
	Clean sediment cup									
	Check muffler									
	Check valve clearance									
	Replace engine oil									
	Replace engine oil filter									
	Replace spark plug									
	Replace air cleaner element									
	Replace fuel filter									
	Check fuel hoses and clamps									
Main vehicle	Check hydraulic hose (Moving part)									
	Check belt									

Records

Records

Items											
Main vehicle	Check electrical wiring										
	Check wheel mounting bolts										
	Check hydraulic hose (Fixed part)										
	Grease and Lubricate										
	Replace hydraulic oil										
	Replace hydraulic oil suction filter										
	Replace hydraulic oil line filter										
	Replace air breather element										
	Replace battery										
	Replace hydraulic hoses (Moving part)										
	Replace hydraulic hoses (Fixed part)										
	Replace Belt										
	Replace brake wire										
	Replace traveling cable										

Records

Items											
Main vehicle	Replace throttle wire										
	Replace choke wire										
	Replace brake shoe										

Records

Records

BARONESS[®]
Quality on Demand

 **KYOEISHA CO., LTD.**
Head Office 1-26, Miyuki-cho, Toyokawa-city, Tel :+81-533-84-1390
Aichi-pref, 442-8530 JAPAN Fax:+81-533-84-1220