

# ***LH62·LH66***

Multi Configuration Mower Unit

## **Service Manual**

Serial No. LH62 : 10001- ▪ LH66 : 10001-

---

**BARONESS**<sup>®</sup>  
Quality on Demand

Ver.1.0

# Introduction

---

This document outlines maintenance procedures, fault diagnosis and other details for the mower unit.

Details have been categorized systematically in accordance with the main types of maintenance.

For repairs, please contact your sales dealer or Kyoisha.

For information on operation, handling and maintenance instructions, please refer to the Owner's Operating Manual.

Refer to the Parts Catalog for required parts.

Kyoisha Co., Ltd.

## Caution

The details included in this document are subject to notice due to improvements.

When replacing parts, always use genuine Baroness parts or parts specified by Kyoisha.

Note that no responsibility will be taken for defects caused by use of non-genuine parts.

## List of Suitable Baroness Machine

The Baroness main body models that can be equipped with the MC mower unit are listed below.

	LH62	LH66	Remarks
	22 in.	26 in.	
LM331	-	○	
LM551	○	○	
LM551A	○	○	
LM2700	○	○	Main body serial number: #11001-
LM2710	-	○	

## Warning Symbols

This manual uses the following warning symbols for handling precautions that are important for your safety.



696cq5-001

Warning symbol

This symbol indicates the articles regarding “Danger,” “Warning,” or “Caution.”

Those articles describe important safety precautions and so read them carefully to understand completely before operating the machine.

Failure to adequately follow these safety precautions may cause an accident.



This symbol indicates that serious injury or death will occur if the warning is ignored.



This symbol indicates that serious injury or death may occur if the warning is ignored.

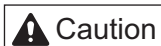

This symbol indicates that injury or damage to property may occur if the warning is ignored.



This symbol indicates precautions on the mechanism of the machine.

LH62 · LH66

# Introduction

---

**Safety ..... Page 1-1**

Safety Precautions ..... Page 1-2

Safety Signs and Instruction Signs ..... Page 1-2

**Disposal ..... Page 2-1**

Recycle and Waste Disposal ..... Page 2-2

**Maintenance standards and maintenance ...Page 3-1**

Unit conversion ..... Page 3-2

Maintenance standards ..... Page 3-4

Tightening torques ..... Page 3-5

General precautions ..... Page 3-7

Greasing ..... Page 3-9

**Operating Machine and Mower Units .....Page 4-1**

Maintenance ..... Page 4-2

Special Tool ..... Page 4-2

Adjustment ..... Page 4-7

Removal and installation of each section .... Page 4-15

Inspection and repair of each section ..... Page 4-35

**Troubleshooting .....Page 5-1**Relating to Operating Machine and  
Mower Unit ..... Page 5-2**Reference .....Page 6-1**

Specifications list ..... Page 6-2

Maintenance Schedule ..... Page 6-4

# Contents

---

**Safety Precautions ..... Page 1-2**

**Safety Signs and Instruction Signs ..... Page 1-2**

About Safety Decals and Instruction  
Decals .....Page 1-2

# Safety

---

Failure to adequately follow these safety precautions may cause an accident resulting in injury or death.

## Danger

This mower unit is designed to ensure safe operation and has been tested and inspected thoroughly before shipment from the factory. The machine is equipped with safety devices to prevent accidents.

However, whether the machine demonstrates its original performance level depends on the manner in which it is operated and handled, as well as the manner in which it is managed on a daily basis.

Inappropriate use or management of the machine may result in injury or death.

Observe the following safety instructions to ensure safe operation.

## Safety Precautions

Read Safe Operating Practices described in the Owner's Operating Manual of Baroness main vehicle equipped with this mower unit thoroughly.

## Safety Signs and Instruction Signs

### About Safety Decals and Instruction Decals

## Warning

Safety decals and instruction decals are attached to this mower unit.

Make sure that decals are preserved in their entirety. If they are damaged, become dirty, or peel off, replace them with new ones.

Part numbers for decals that need to be replaced are listed in the parts catalog. Order them from a Baroness dealer or Kyo-eisha.

**Recycle and Waste Disposal ..... Page 2-2**

About Recycle .....Page 2-2

About the Waste disposal ..... Page 2-2

# Disposal

---

## Recycle and Waste Disposal

### About Recycle

Recycling battery etc. is recommended for environmental conservation and economical use of resources.

It may be required by local laws.

### About the Waste disposal

Make sure that waste generated when servicing or repairing the machine is disposed of in accordance with local regulations. (e.g. waste oil, antifreeze, rubber products, and wires etc.)

# Maintenance standards and maintenance

---

**Unit conversion .....Page 3-2**

Inch-millimeter conversion table ..... Page 3-2

US unit-SI unit conversion table .....Page 3-3

**Maintenance standards .....Page 3-4**

List of Maintenance Specifications ..... Page 3-4

**Tightening torques ..... Page 3-5**

Standard tightening torques ..... Page 3-5

Principal tightening torques ..... Page 3-6

**General precautions ..... Page 3-7**

Bearing ..... Page 3-7

Stop Ring ..... Page 3-8

**Greasing ..... Page 3-9**

About Greasing .....Page 3-9

Greasing Points ..... Page 3-9

# Maintenance standards and maintenance

## Unit conversion

### Inch-millimeter conversion table

1 mm = 0.03937 in

1 in = 25.4 mm

Fractions		Decimals	mm	Fractions		Decimals	mm
	1/64	0.015625	0.397		33/64	0.515625	13.097
	1/32	0.03125	0.794		17/32	0.53125	13.494
	3/64	0.046875	1.191		35/64	0.546875	13.891
1/16		0.0625	1.588	9/16		0.5625	14.288
	5/64	0.078125	1.984		37/64	0.578125	14.684
	3/32	0.09375	2.381		19/32	0.59375	15.081
	7/64	0.109275	2.778		39/64	0.609375	15.478
1/8		0.1250	3.175	5/8		0.6250	15.875
	9/64	0.140625	3.572		41/64	0.640625	16.272
	5/32	0.15625	3.969		21/32	0.65625	16.669
	11/64	0.171875	4.366		43/64	0.671875	17.066
3/16		0.1875	4.762	11/16		0.6875	17.462
	13/64	0.203125	5.159		45/64	0.703125	17.859
	7/32	0.21875	5.556		23/32	0.71875	18.256
	15/64	0.234375	5.953		47/64	0.734375	18.653
1/4		0.2500	6.350	3/4		0.7500	19.050
	17/64	0.265625	6.747		49/64	0.765625	19.447
	9/32	0.28125	7.144		25/32	0.78125	19.844
	19/64	0.296875	7.541		51/64	0.796875	20.241
5/16		0.3125	7.938	13/16		0.8125	20.638
	21/64	0.328125	8.334		53/64	0.828125	21.034
	11/32	0.34375	8.731		27/32	0.84375	21.431
	23/64	0.359375	9.128		55/64	0.859375	21.828
3/8		0.3750	9.525	7/8		0.8750	22.225
	25/64	0.390625	9.922		57/64	0.890625	22.622
	13/32	0.40625	10.319		29/32	0.90625	23.019
	27/64	0.421875	10.716		59/64	0.921875	23.416
7/16		0.4375	11.112	15/16		0.9375	23.812
	29/64	0.453125	11.509		61/64	0.953125	24.209
	15/32	0.46875	11.906		31/32	0.96875	24.606
	31/64	0.484375	12.303		63/64	0.984375	25.003
1/2		0.5000	12.700	1		1.000	25.400

# Maintenance standards and maintenance

## US unit-SI unit conversion table

To Convert			Into		Multiply By
Linear Measurement	Miles	mi	Kilometers	km	1.609
	Yards	yd	Meters	m	0.9144
	Feet	ft	Meters	m	0.3048
	Feet	ft	Centimeters	cm	30.48
	Inches	in	Meters	m	0.0254
	Inches	in	Centimeters	cm	2.54
	Inches	in	Millimeters	mm	25.4
Area	Square Miles	mile <sup>2</sup>	Square Kilometers	km <sup>2</sup>	2.59
	Square Feet	ft <sup>2</sup>	Square Meters	m <sup>2</sup>	0.0929
	Square Inches	in <sup>2</sup>	Square Centimeters	cm <sup>2</sup>	6.452
	Acre	ac	Hectare	ha	0.4047
Volume	Cubic Yards	yd <sup>3</sup>	Cubic Meters	m <sup>3</sup>	0.7646
	Cubic Feet	ft <sup>3</sup>	Cubic Meters	m <sup>3</sup>	0.02832
	Cubic Inches	in <sup>3</sup>	Cubic Centimeters	cm <sup>3</sup>	16.39
Weight	Tons (Short)	sh tn	Metric Tons	ton	0.9078
	Pounds	lb	Kilograms	kg	0.4536
	Ounces (Avdp.)	oz	Grams	g	28.3495
Pressure	Pounds/Sq. In.	psi	Kilopascal	kPa	6.895
	Pounds/Sq. In.	psi	Bar	mdyn/cm <sup>2</sup>	0.069
Work	Foot-pounds	lb-ft	Newton-Meters	N-m	1.356
	Foot-pounds	lb-ft	Kilogram-Meters	kgf-m	0.1383
	Inch-pounds	lb-in	Kilogram-Centimeters	kgf-cm	1.152144
Liquid Volume	Quarts	qt (US)	Liters	L	0.9463
	Gallons	gal (US)	Liters	L	3.785
Liquid Flow	Gallons/Minute	gal/min	Liters/Minute	L/min	3.785
Temperature	Fahrenheit	°F	Celsius	°C	1. Subtract 32 ° 2. Multiply by 5/9

# Maintenance standards and maintenance

## Maintenance standards

### List of Maintenance Specifications

Item		Adjusted Value		Remarks
		LH62	LH66	
Cutter adjustment spring		27.0 mm (1.06 in)	←	Spring coil length
Front roller spring		1.0 - 3.0 mm (0.039 - 0.118 in)	←	Front roller spring clearance
Front roller assy		593.5 mm (23.36 in)	696.0 mm (27.40 in)	Front roller assy total length
Groomer spring		45.0 mm (1.77 in)	←	Spring coil length
CR brush drive belt	Type with only CR brush installed	5.0 - 6.0 mm (0.197 - 0.236 in)	←	Slack with 10.0 N (1.0 kgf) force applied around center section between belt pulleys
	Type with groomer installed together	63.0 - 65.0 mm (2.48 - 2.56 in)	←	Spring coil length
CR brush	Type with only CR brush installed	0 - 1.0 mm (0 - 0.039 in)	←	Brush and rear roller clearance
	Type with groomer installed together	0 - 1.0 mm (0 - 0.039 in)	←	Brush and rear roller clearance
Front scraper		2.0 - 3.0 mm (0.079 - 0.118 in)	←	Scraper and roller outer diameter surface clearance
Rear scraper		2.0 - 3.0 mm (0.079 - 0.118 in)	←	Scraper and roller clearance
Reel cutter usage limit (outer dimensions)		143.0 mm (56.30 in)	←	Replace if below standard values

# Maintenance standards and maintenance

## Tightening torques

### Standard tightening torques

#### Bolts and Nuts

##### Important

A number of bolts are used in each part of this machine.  
Be sure to re-tighten the bolts and nuts, because they may be loosened at the earlier stage of the use.

As to the bolts and nuts without any special instruction, tighten them in appropriate tightening torque with proper tool.

Too much tightening may cause the looseness or damage of the screw.

The strength of tightening is determined by types of screws, strength, the friction of thread face or base face and others.

The table below is for the galvanized or parkerized bolts.

In case that the strength of internal thread is weak, it is not applied.

Do not use rusty or sand attached "screw."

Otherwise, it may cause insufficient tightening even if you apply the specified tightening torque.

The friction of the screw face becomes higher and the tightening torque is canceled out by the friction, therefore sufficient tightening cannot be applied.

If "screw" is wet by water or oil, do not tighten it with normal tightening torque.

If the screw is wet, the torque coefficient will get smaller and it may result in too much tightening.

Too much tightening may cause looseness by the screw stretched or result in damage.

Do not use a bolt experienced too much burden.

Using the impact wrench requires the skill.

Do exercise as much as possible for steady tightening.

Nominal diameter	General bolt		
	Strength classification 4.8		
			
	N-m	kgf-cm	lb-in
M5	3 - 5	30.59 - 50.99	26.55 - 44.26
M6	7 - 9	71.38 - 91.77	61.96 - 79.66
M8	14 - 19	142.76 - 193.74	123.91 - 168.17
M10	29 - 38	295.71 - 387.49	256.68 - 336.34
M12	52 - 67	530.24 - 683.20	460.25 - 593.02
M14	70 - 94	713.79 - 958.52	619.57 - 831.99
M16	88 - 112	897.34 - 1142.06	778.89 - 991.31
M18	116 - 144	1,182.85 - 1,468.37	1,026.72 - 1,274.54
M20	147 - 183	1,498.96 - 1,866.05	1,301.10 - 1,619.73
M22	295	3,008.12	2,611.05
M24	370	3,772.89	3,274.87
M27	550	5,608.35	4,868.05
M30	740	7,545.78	6,549.74

# Maintenance standards and maintenance

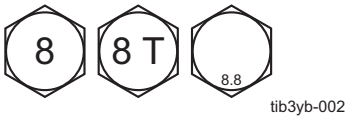
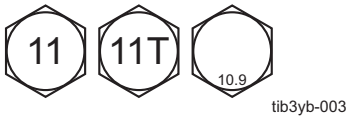
Nominal diameter	Heat-treated bolt					
	Strength classification 8.8			Strength classification 10.9		
						
	N-m	kgf-cm	lb-in	N-m	kgf-cm	lb-in
M5	5 - 7	50.99 - 71.38	44.26 - 61.96	7 - 10	71.38 - 101.97	61.96 - 88.51
M6	8 - 11	81.58 - 112.17	70.81 - 97.36	14 - 18	142.76 - 183.55	123.91 - 159.32
M8	23 - 29	234.53 - 295.71	203.57 - 256.68	28 - 38	285.52 - 387.49	247.83 - 336.34
M10	45 - 57	458.87 - 581.23	398.30 - 504.51	58 - 76	591.43 - 774.97	513.36 - 672.68
M12	67 - 85	683.20 - 866.75	593.02 - 752.34	104 - 134	1,060.49 - 1,366.40	920.50 - 1186.03
M14	106 - 134	1,080.88 - 1,366.40	938.21 - 1,186.03	140 - 188	1,427.58 - 1,917.04	1,239.14 - 1,663.99
M16	152 - 188	1,549.94 - 1,917.04	1,345.35 - 1,663.99	210 - 260	2,141.37 - 2,651.22	1,858.71 - 2,301.26
M18	200 - 240	2,039.40 - 2,447.28	1,770.20 - 2,124.24	280 - 340	2,855.16 - 3,466.98	2,478.28 - 3,009.34
M20	245 - 295	2,498.27 - 3,008.12	2,168.50 - 2,611.05	370 - 450	3,772.89 - 4,588.65	3,274.87 - 3,982.95
M22	-	-	-	530	5,404.41	4,691.03
M24	-	-	-	670	6,831.99	5,930.17
M27	-	-	-	1,000	10,197.00	8,851.00
M30	-	-	-	1,340	14,628.78	11,860.34

**Note:**

The same values are applied to "fine screw thread."

## Principal tightening torques

### Tightening Torque by Model

LH66/LH62

LS66/LS62

Tighten the following bolts and nuts at the torque specified in the table.

For thread locking adhesive, apply a middle strength thread locker (ThreeBond 1322 or equivalent anaerobic sealant).

Location	Code	Part name	Tightening torque			Thread locking adhesive
			N-m	kgf-cm	lb-in	
Bed knife	K0071000092	SCREW, HT FLAT HEAD M10-20	29 - 38	295.71 - 387.49	256.68 - 336.34	-

# Maintenance standards and maintenance

## General precautions

### Bearing

The bearing is a precision machine part. Install the bearing in an appropriate work environment so that dust does not enter the interior, and be extremely careful not to subject the bearing to strong impact. To install the bearing correctly, use a bearing driver.

**⚠ Caution**

Be careful not to hit your hand with a hammer etc.

1. When pressing the bearing into the shaft, apply pressure evenly around the inner ring of the bearing using the bearing driver.

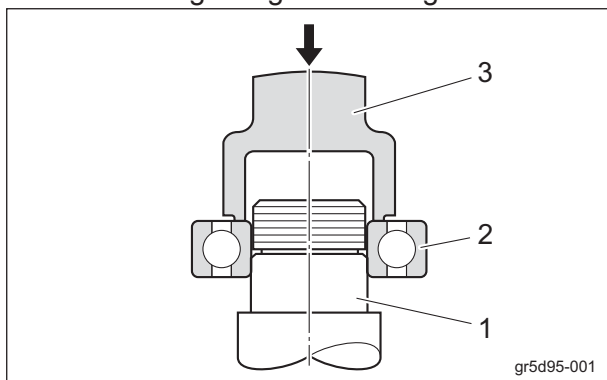

Bearing\_001

1	Shaft
2	Bearing
3	Bearing driver

2. When pressing the bearing into the housing, apply pressure evenly around the outer ring of the bearing using the bearing driver.

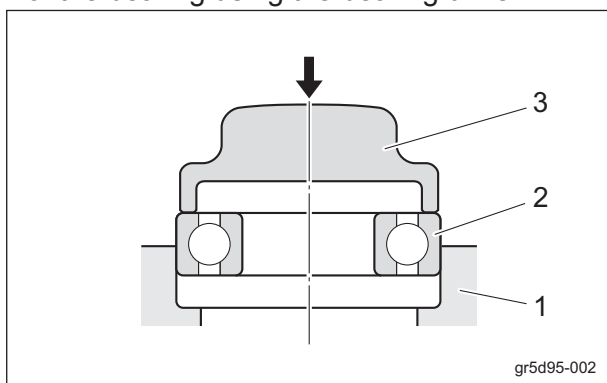

Bearing\_002

1	Housing
2	Bearing
3	Bearing driver

3. When pressing the bearing into the shaft and housing evenly, apply pressure evenly with the bearing driver in contact with the inner ring and outer ring of the bearing.

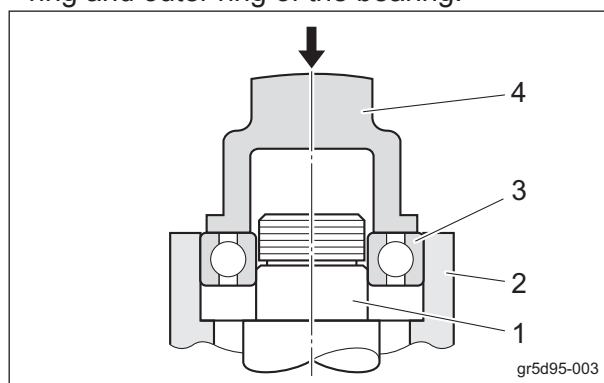

Bearing\_003

1	Shaft
2	Housing
3	Bearing
4	Bearing driver

# Maintenance standards and maintenance

## Stop Ring

**⚠ Caution**

When attaching the stop ring to a hole or a shaft, the stop ring may become disengaged from the dedicated pliers, fly off, and cause injury. Take extra precautions to ensure that the stop ring does not become disengaged from the pliers.

**⚠ Caution**

When attaching the stop ring to a hole or a shaft, do not contract or expand the stop ring more than necessary. Excessive contraction or expansion of the stop ring may cause increased deformation, which may lead to play and disengagement from the groove.

1. There are two types of stop rings: one for a hole and one for a shaft. Both stop rings have a front and a back. The front side is rounded, and the back side has a sharp edge.

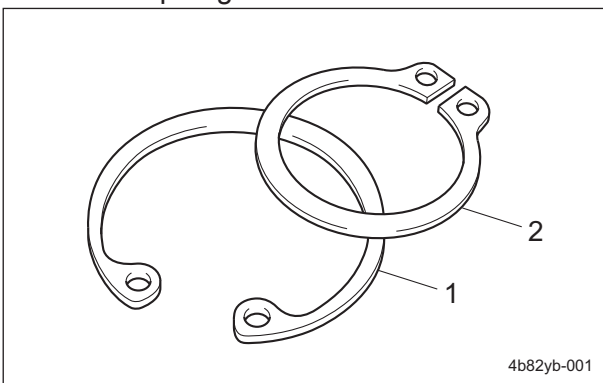

Stop Ring\_001

1	Stop ring for hole
2	Stop ring for shaft

2. When attaching the stop ring for a shaft, assemble the stop ring so that the sharp edge side receives the load (indicated by an arrow).

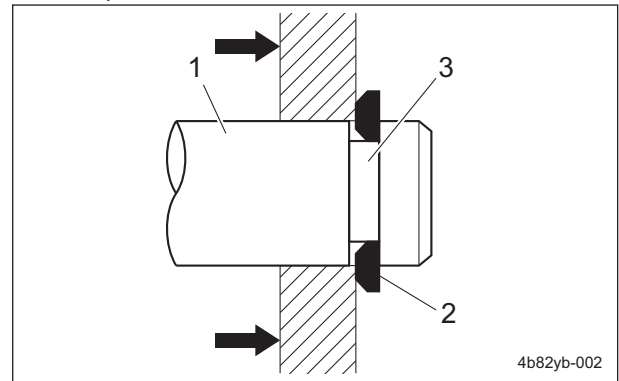

Stop Ring\_002

1	Shaft
2	Stop ring (sharp edge side)
3	Stop ring groove

3. When attaching the stop ring for a hole, assemble the stop ring so that the sharp edge side receives the load (indicated by an arrow).

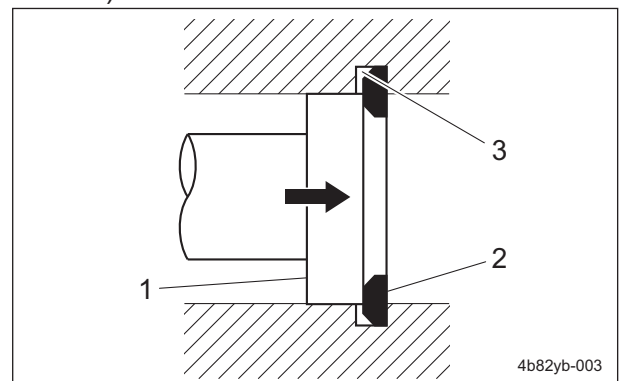

Stop Ring\_003

1	Shaft
2	Stop ring (sharp edge side)
3	Stop ring groove

# Maintenance standards and maintenance

## Greasing

### About Greasing

Since there may be adhesion or damage due to lack of grease on moving parts, they must be greased.

Add urea-based No. 2 grease in accordance with the Maintenance Schedule.

Other locations where the specified grease or lubricant is used are indicated in "Greasing Points".

Add grease using the specified grease or lubricant.

### Greasing Points

Grease nipples are installed in the following locations.

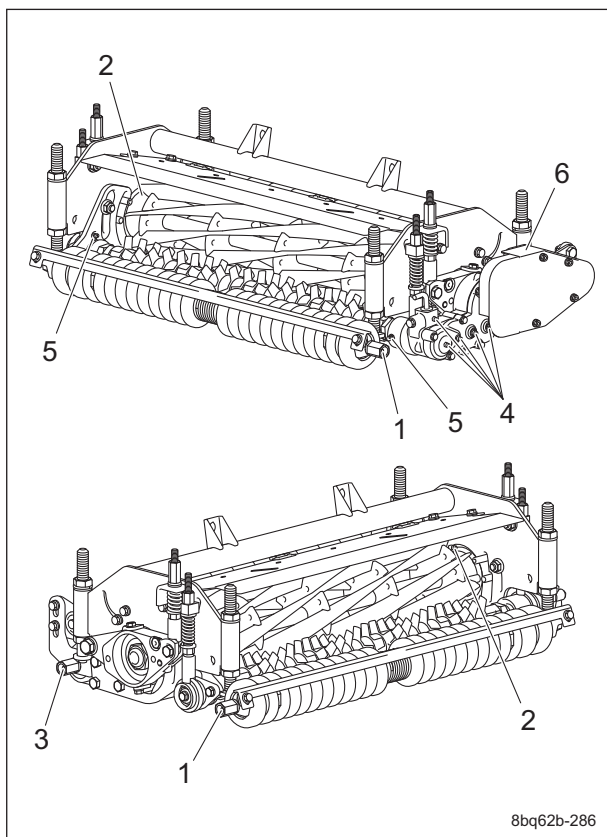

Greasing Points\_001

	Location	No. of greasing points	Greasing period	
1	Front roller shaft	2	-	B
2	Reel housing	2	-	B
3	Rear roller shaft	2	-	B
4	Groomer case	5	A	B
5	Groomer shaft	2	-	B
6	CR brush tension lever	1	-	B

Add grease to A every 10 hours and B every 50 hours.

#### 1. Front roller shaft

There is one point each on the left and right of the front roller shaft.

Left end of front roller

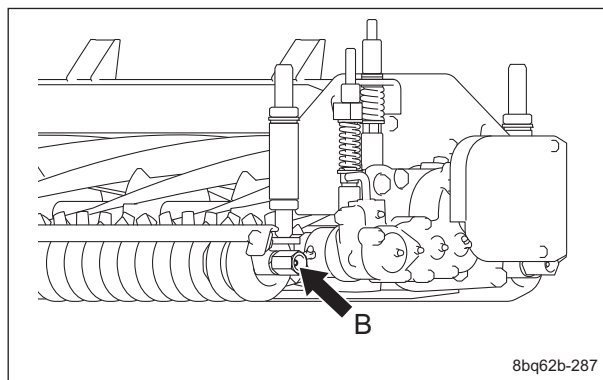

Greasing Points\_002

Right end of front roller

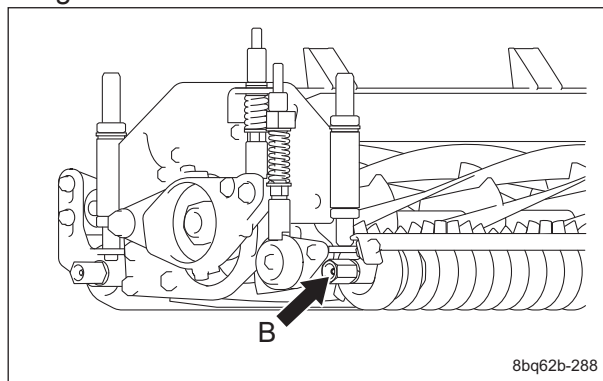

Greasing Points\_003

#### 2. Reel housing

There is one point each on the left and right of the reel housing.

Left reel housing

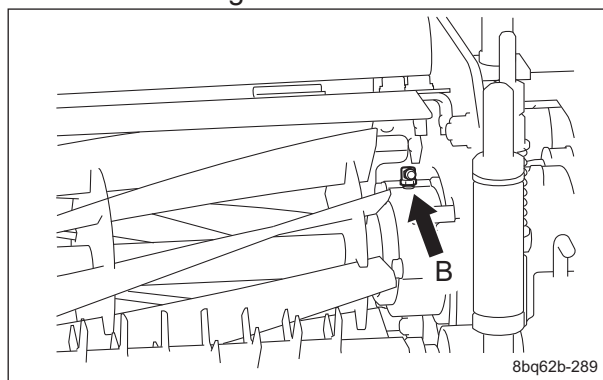

Greasing Points\_004

# Maintenance standards and maintenance

## Right reel housing

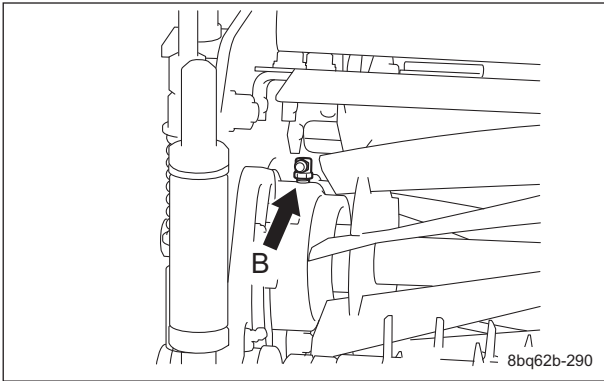

Greasing Points\_005

## 3. Rear roller shaft

There is one point each on the left and right of the rear roller shaft.

Left end of rear roller

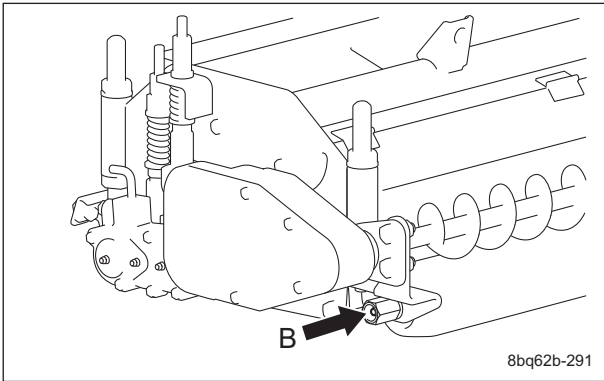

Greasing Points\_006

Right end of rear roller

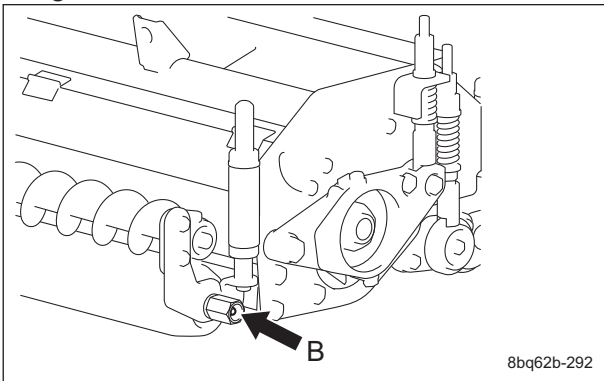

Greasing Points\_007

## 4. Groomer case

Note:

Depending on the specifications, this function may not be available.

There are five points on the groomer case.

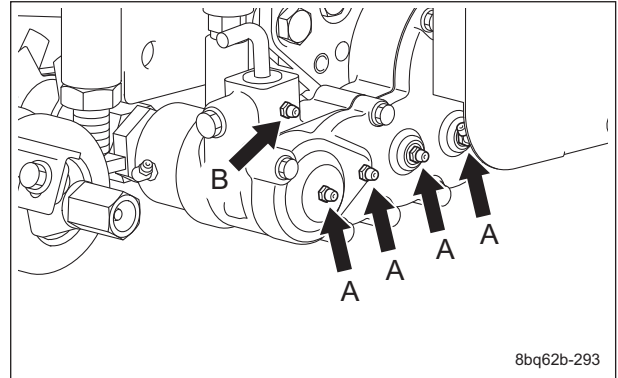

Greasing Points\_008

## 5. Groomer shaft

Note:

Depending on the specifications, this function may not be available.

There is one point each on the left and right of the groomer shaft.

Groomer case side

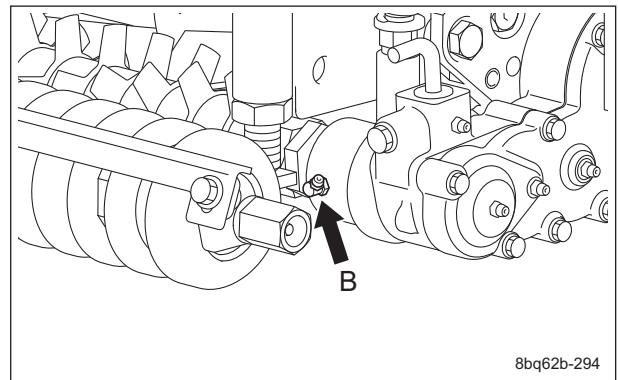

Greasing Points\_009

Reel motor side

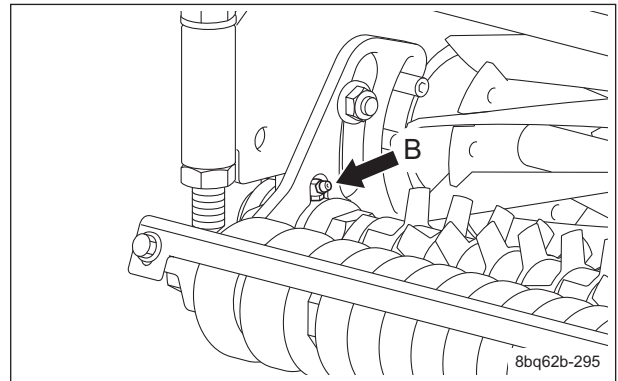

Greasing Points\_010

# Maintenance standards and maintenance

## 6. CR brush tension lever (Groomer + CR brush installation)

Note:

Depending on the specifications, this function may not be available.

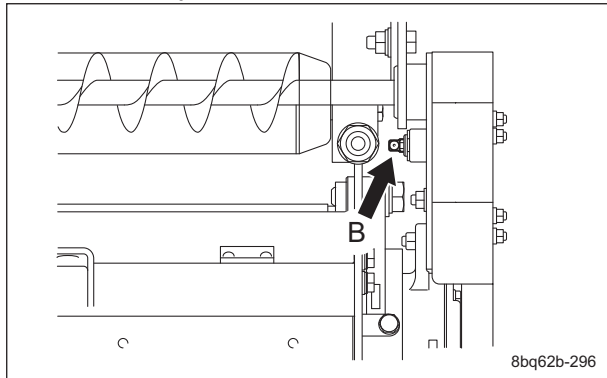

Greasing Points\_011

# Maintenance standards and maintenance

---

# Operating Machine and Mower Units

## **Maintenance ..... Page 4-2**

About Maintenance ..... Page 4-2

## **Special Tool ..... Page 4-2**

List of Special Tools ..... Page 4-2

## **Adjustment ..... Page 4-7**

Adjustment of Blade Engagement ..... Page 4-7

Adjustment of Cutting Height ..... Page 4-8

Adjustment of Cutter Adjustment  
Spring ..... Page 4-9

Adjustment of Reel Cover (Variable  
Type) ..... Page 4-9

Adjustment of Groomer ..... Page 4-10

Adjustment of Groomer Spring ..... Page 4-11

Adjustment of CR brush ..... Page 4-11

Adjustment of Scraper ..... Page 4-12

Adjustment of Belt Tension ..... Page 4-13

## **Removal and installation of each section ..... Page 4-15**

Reel cover ..... Page 4-15

Bed Knife Mounting Assy ..... Page 4-16

Bed knife ..... Page 4-18

Reel Cutter ..... Page 4-19

Front Roller Assy ..... Page 4-24

Rear Roller Assy ..... Page 4-26

Groomer Case Assy ..... Page 4-27

Groomer shaft assy ..... Page 4-30

CR Brush Assy ..... Page 4-32

## **Inspection and repair of each section ..... Page 4-35**

Reel Cover ..... Page 4-35

Reel cutter ..... Page 4-35

Reel Housing ..... Page 4-40

Reel Housing (with housing lid) ..... Page 4-41

Bed knife ..... Page 4-42

Roller ..... Page 4-43

Groomer Assy ..... Page 4-49

CR Brush Assy ..... Page 4-56

# Operating Machine and Mower Units

## Maintenance

### About Maintenance

This chapter describes primary checking and maintenance operations for the MC mower unit.

For information on daily checks, maintenance and handling of the mower unit, please refer to the separate MC Mower Unit's Owner's Operating Manual and Parts Catalog.

For information on attaching and removing optional parts and attachments, please refer to the handling manual for the corresponding attachment.

## Special Tool

### List of Special Tools

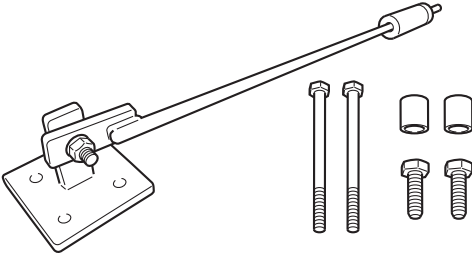
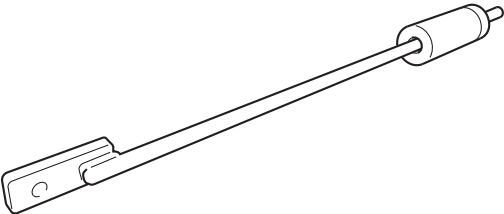
<p>Sliding hammer 318</p>  <p style="text-align: right;">q9c6v6-023</p>	<p>K4802000460</p>	<p>Used when removing the reel housing and other parts.</p>
<p>Sliding hammer</p>  <p style="text-align: right;">q9c6v6-024</p>	<p>K480200047D</p>	<p>One of the parts that compose the sliding hammer 318 and used together with the mounting bracket.</p>

# Operating Machine and Mower Units

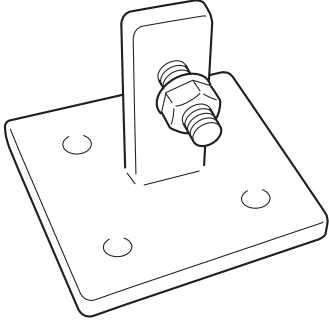
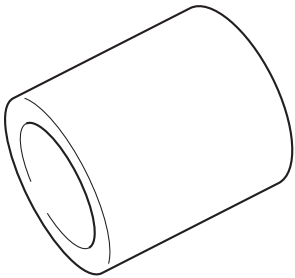
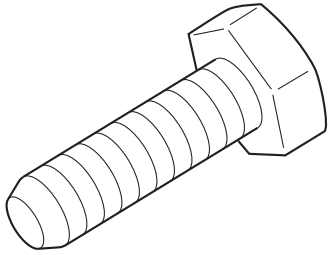
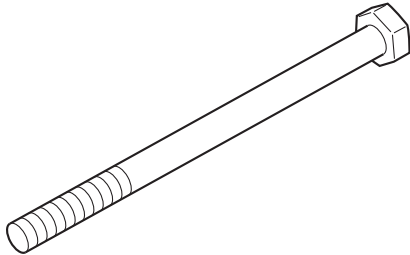
<p>Mounting bracket</p>  <p style="text-align: right;">q9c6v6-025</p>	K480200048D	<p>One of the parts that compose the sliding hammer 318 and used by being mounted on the gear motor and housing.</p>
<p>12.7 collar 17.320.2</p>  <p style="text-align: right;">q9c6v6-026</p>	K6211000012	<p>One of the parts that compose the sliding hammer 318 and used between the gear motor and mounting bracket.</p>
<p>Bolt, M10-30</p>  <p style="text-align: right;">q9c6v6-027</p>	K0000100302	<p>One of the parts that compose the sliding hammer 318 and used to remove the housing, etc.</p>
<p>Bolt, M12-140</p>  <p style="text-align: right;">q9c6v6-028</p>	K0003121402	<p>One of the parts that compose the sliding hammer 318 and used to remove the gear motor.</p>

# Operating Machine and Mower Units

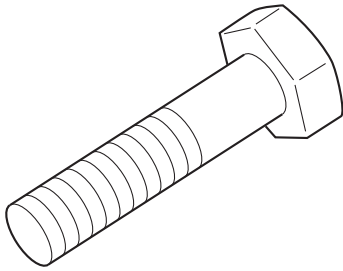
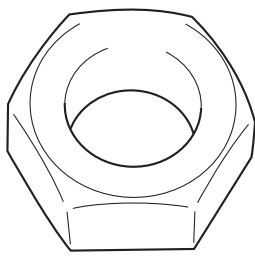
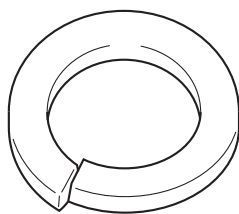
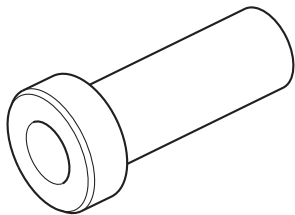
<p>Bolt, heat-treated M14-50</p>  <p>q9c6v6-029</p>	<p>K0013140502</p>	<p>One of the parts that compose the sliding hammer 318 and used to fix the sliding hammer and mounting bracket.</p>
<p>14 Nut</p>  <p>q9c6v6-030</p>	<p>K0100140002</p>	<p>One of the parts that compose the sliding hammer 318 and used to fix the sliding hammer and mounting bracket.</p>
<p>Spring washer 14</p>  <p>q9c6v6-031</p>	<p>K0200140002</p>	<p>One of the parts that compose the sliding hammer 318 and used to fix the sliding hammer and mounting bracket.</p>
<p>6005 Bearing driver</p>  <p>q9c6v6-009</p>	<p>K4802000502</p>	<p>Used when installing bearings with outer <math>\varnothing 47</math> and inner <math>\varnothing 25</math>.</p>

# Operating Machine and Mower Units

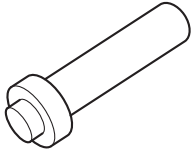
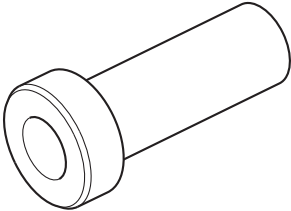
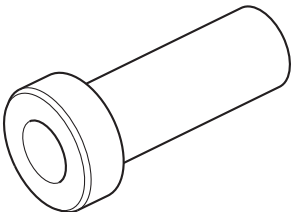
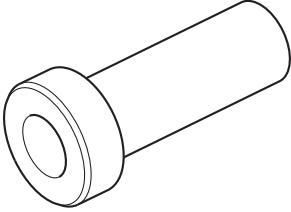
<p>34 Oil seal installer</p>  <p>q9c6v6-036</p>	<p>K4802000522</p>	<p>Used to knock-in and install outer diameter <math>\phi</math>34 oil seals.</p>
<p>6303 Bearing driver</p>  <p>q9c6v6-009</p>	<p>K4802000752</p>	<p>Used when installing bearings with outer <math>\phi</math>47 and inner <math>\phi</math>17.</p>
<p>6206 Bearing driver</p>  <p>q9c6v6-009</p>	<p>K4802000832</p>	<p>Used when installing bearings with outer <math>\phi</math>62 and inner <math>\phi</math>30.</p>
<p>6003 Bearing driver</p>  <p>q9c6v6-009</p>	<p>K4802000842</p>	<p>Used when installing bearings with outer <math>\phi</math>35 and inner <math>\phi</math>17.</p>

# Operating Machine and Mower Units

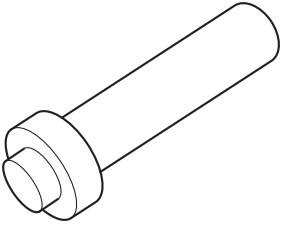
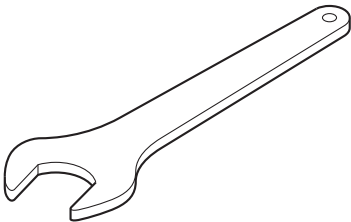
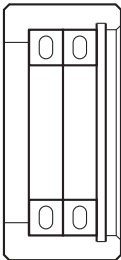
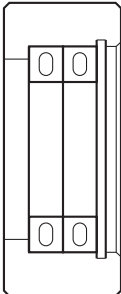
<p>35 Oil seal installer</p>  <p style="text-align: right;">q9c6v6-011</p>	<p>K4802000782</p>	<p>Used to knock-in and install <math>\phi 35</math> oil seals.</p>
<p>46 Single head wrench</p>  <p style="text-align: right;">q9c6v6-032</p>	<p>K480200081D</p>	<p>Used to disassemble or assemble the front roller.</p>
<p>Holder Assy <math>\phi 52</math></p>  <p style="text-align: right;">q9c6v6-051</p>	<p>LM2700-9146Z0</p>	<p>Used when setting the reel cutter in the grinding machine. Holder outer diameter <math>\phi 52</math></p>
<p>Holder Assy <math>\phi 60</math></p>  <p style="text-align: right;">q9c6v6-052</p>	<p>LM2700-9147Z0</p>	<p>Used when setting the reel cutter in the grinding machine. Holder outer diameter <math>\phi 60</math></p>

# Operating Machine and Mower Units

## Adjustment

### Adjustment of Blade Engagement

**⚠ Danger**

Make sure that the parking brake is firmly applied before performing the operation.

**⚠ Caution**

Be sure to perform this operation on your own.

**⚠ Caution**

Be sure to stop the engine before adjusting the blade engagement.

**⚠ Caution**

When handling the reel cutter (cutting cylinder) or bed knife (bottom blade), wear gloves to protect your hands. Pay attention not to let the reel cutter (cutting cylinder) catch your gloves. Otherwise, you may injure your hand or fingers.

**Important**

If the CR brush is installed (the mower unit equipped with only CR brush), loosen the left and right bolts and nuts used to install the CR brush before adjusting the blade engagement. After adjusting the blade engagement, adjust the CR brush, and then firmly tighten the loosened bolts and nuts.

1. Stop the engine.
2. Shift the reel rotation/stop switching lever to the "Stop" position.

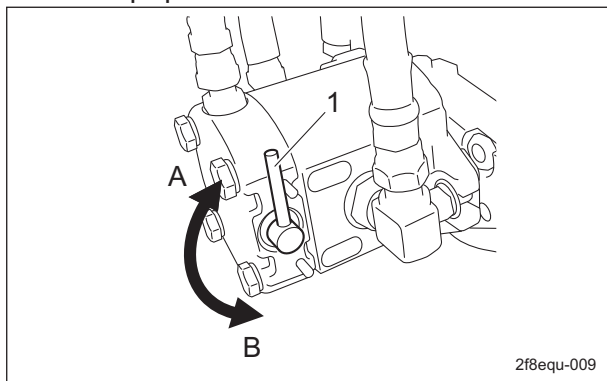

Adjustment of Blade Engagement\_001

1	Reel rotation/stop switching lever
A	Rotation
B	Stop

3. With the cutter adjustment nut, adjust the engagement between the reel cutter (cutting cylinder) and the bed knife (bottom blade) so that newspaper (two to three sheets) will be cut by the edge of both blades when the blades in their entirety come slightly into contact with each other.

4. Insert two or three strips of newspaper into the space between the reel cutter (cutting cylinder) and the bed knife (bottom blade) at an angle of 90 degrees. Then, rotate the reel cutter (cutting cylinder) counter-clockwise (when you face the mower unit from the left) by hand to check the sharpness of the blades.

Check the sharpness of the entire range (at three or four points between the left and right ends) of the reel cutter (cutting cylinder).

- If there is a gap between the blade edges: Loosen the cutter adjustment nut to apply more contact pressure between the reel cutter (cutting cylinder) and the bed knife (bottom blade).
- If the reel cutter (cutting cylinder) is too tight to turn: Tighten the cutter adjustment nut to reduce the contact pressure between the reel cutter (cutting cylinder) and the bed knife (bottom blade).
- If the blades still cannot cut well: Perform back lapping of the reel cutter (cutting cylinder).

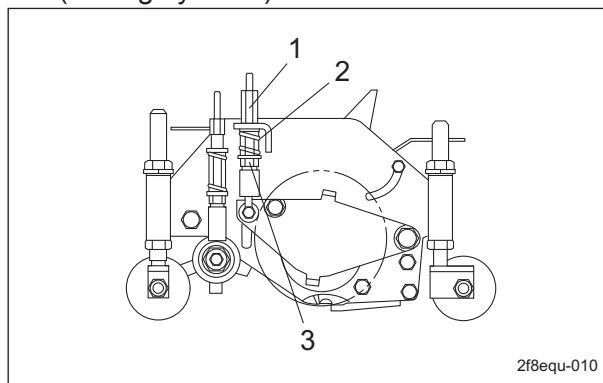

Adjustment of Blade Engagement\_002

1	Cutter adjustment nut
2	Spring
3	Pipe with cutter adjustment screw

# Operating Machine and Mower Units

## Adjustment of Cutting Height

### Cutting Height Adjustment

**⚠ Caution**

Do not perform the operation with any other persons.

Adjust the cutting height to fit your cutting work.

1. Set the enclosed cutting height gauge.

[1] Set the small screw for cutting height setup to the cutting height.

[2] Set the angle of the bed knife (bottom blade) with the small screw for bed knife angle adjustment.

"Bed Knife (Bottom Blade) Angle Table" (Page 4-9)

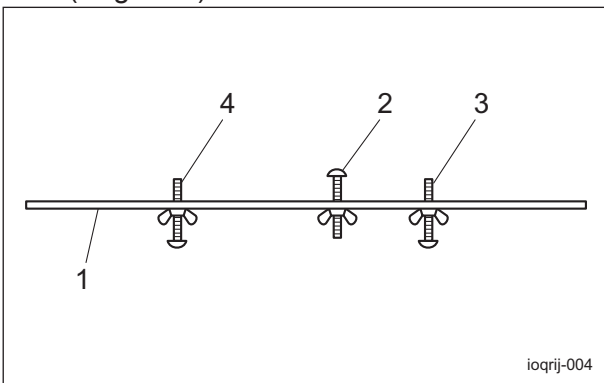

Cutting Height Adjustment\_001

1	Cutting height gauge
2	Small screw for cutting height setup
3	Small screw for bed knife angle adjustment
4	Small screw for groomer adjustment

2. Position the small screw for cutting height setup set on the cutting height gauge as well as the small screw for bed knife angle adjustment against the bed knife (bottom blade), and then adjust the rear roller.

[1] Adjust the left and right ends of the bed knife (bottom blade) until it is level, and then determine the position of the rear roller based on the angle of the bed knife (bottom blade).

[2] Loosen the cutting height adjustment nuts, and then adjust the rear roller so that it comes into contact with the cutting height gauge.

Since the rear roller cannot be accurately adjusted if the front roller is in contact with the cutting height gauge, raise the front roller so it is not in contact with the cutting height gauge.

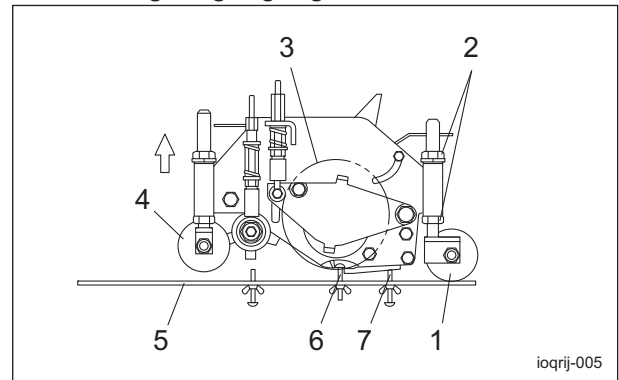

Cutting Height Adjustment\_002

1	Rear roller
2	Cutting height adjustment nut
3	Reel cutter (cutting cylinder)
4	Front roller
5	Cutting height gauge
6	Small screw for cutting height setup
7	Small screw for bed knife angle adjustment

3. After making adjustments, firmly tighten the cutting height adjustment nuts.

4. Loosen the cutting height adjustment nuts, and then adjust the front roller so that it comes into contact with the cutting height gauge.

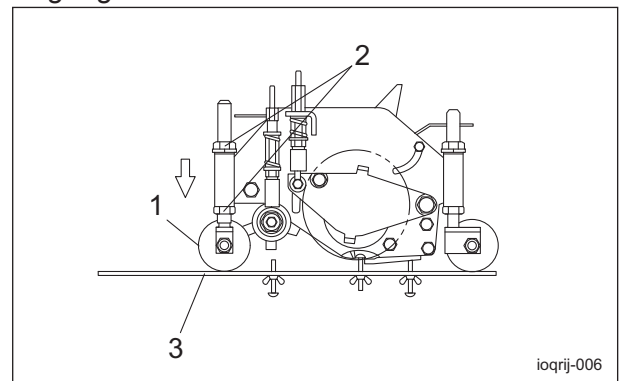

Cutting Height Adjustment\_003

1	Front roller
2	Cutting height adjustment nut
3	Cutting height gauge

# Operating Machine and Mower Units

5. After making adjustments, firmly tighten the cutting height adjustment nuts.

## Bed Knife (Bottom Blade) Angle Table

Make adjustments according to the conditions based on a bed knife (bottom blade) angle of 5°.

<Example>

For a bed knife (bottom blade) angle of 5° at a cutting height of 15.0 mm (0.59 in), set the height of the bottom of the bed knife (bottom blade) to 12.0 mm (0.47 in).

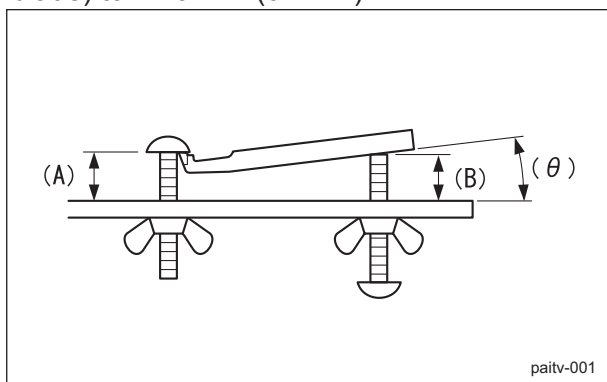

Bed Knife (Bottom Blade) Angle Table\_001

A	Cutting height
B	Height of bottom of bed knife (bottom blade)
θ	Bed knife (bottom blade) angle

Bed knife (bottom blade) angle (θ)	Value of (B)
7°	Cutting height (A)-0.6 mm (-0.02 in)
6°	Cutting height (A)-1.8 mm (-0.07 in)
5°	Cutting height (A)-3.0 mm (-0.12 in)
4°	Cutting height (A)-4.2 mm (-0.17 in)
3°	Cutting height (A)-5.4 mm (-0.21 in)
2°	Cutting height (A)-6.6 mm (-0.26 in)
1°	Cutting height (A)-7.8 mm (-0.31 in)

## Adjustment of Cutter Adjustment Spring

If the diameter of the reel cutter (cutting cylinder) becomes smaller, adjust the cutter adjustment spring.

1. Adjust the blade engagement.
2. Loosen the pipe with cutter adjustment screw and adjust it so that the length of the spring coil is approximately 27.0 mm (1.06 in).

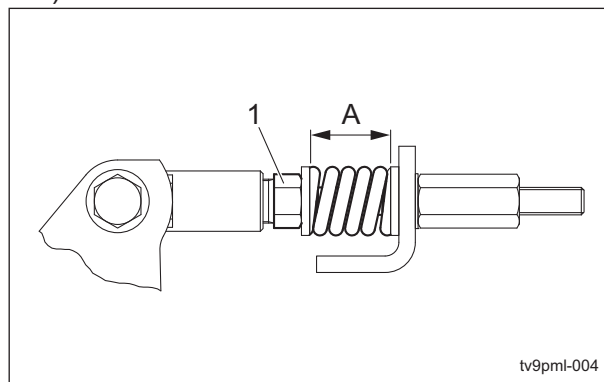

Adjustment of Cutter Adjustment Spring\_001

1	Pipe with cutter adjustment screw
A	27.0 mm (1.06 in)

## Adjustment of Reel Cover (Variable Type)

The angle of the reel cover can be adjusted. Loosen the left and right bolts securing the reel cover, and then adjust the angle of the cover. If the grass catcher is installed, position the reel cover as follows.

- Front collection: Close the reel cover.
- Rear collection: Open the reel cover.

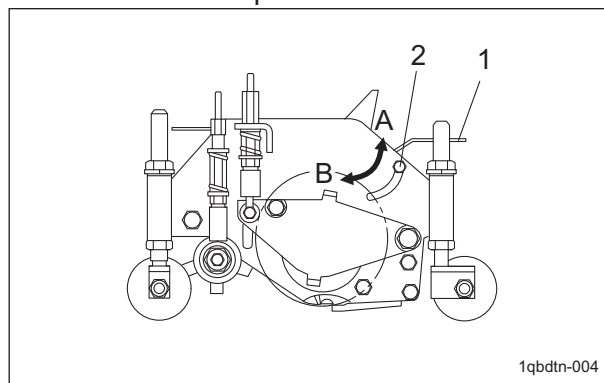

Adjustment of Reel Cover (Variable Type)\_001

1	Reel cover
2	Lock bolt
A	Open
B	Close

# Operating Machine and Mower Units

## Adjustment of Groomer

Note:

Depending on the specifications, this function may not be available.

**⚠ Caution**

For adjustment, be sure to use the cutting height gauge so that the right and left sides can be parallel. Otherwise it may cause damage on the bearings.

**⚠ Caution**

Set the groomer height more than 5.0 mm (0.2 in) from the ground. If it is set lower, the groomer shaft, bearings, gears, etc., may be damaged.

Adjust the cutting height according to the grooming work.

1. Set the small screw for groomer adjustment of the cutting height gauge to the desired height.

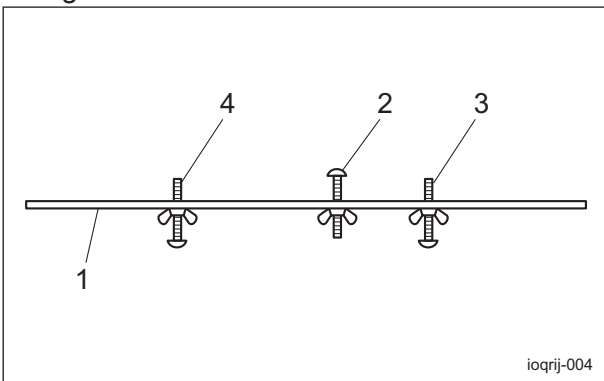

Adjustment of Groomer\_001

1	Cutting height gauge
2	Small screw for cutting height setup
3	Small screw for bed knife angle adjustment
4	Small screw for groomer adjustment

2. Loosen the nut securing the rod holder.

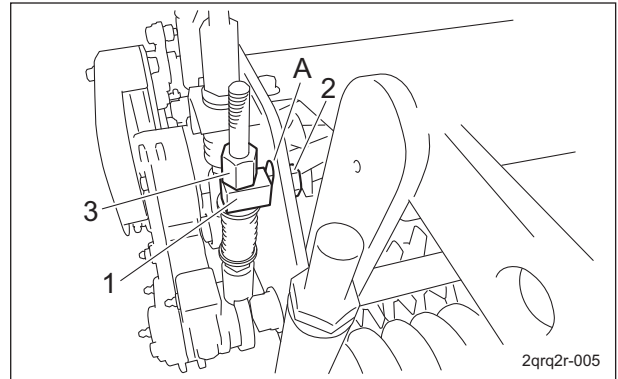

Adjustment of Groomer\_002

1	Rod holder
2	Nut
3	Groomer adjustment nut
A	Long hole

3. Lower the groomer to the bottom of the long hole.
4. Tighten the nut to firmly secure the rod holder.
5. Adjust the height with the groomer adjustment nut.
6. If the groomer is not used, raise the groomer to the top of the long hole.

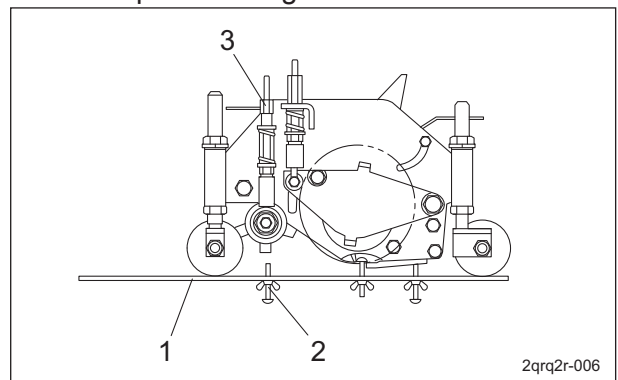

Adjustment of Groomer\_003

1	Cutting height gauge
2	Small screw for groomer adjustment
3	Groomer adjustment nut

# Operating Machine and Mower Units

## Adjustment of Groomer Spring

Note:  
Depending on the specifications, this function may not be available.

**Caution**

The reel cutter (cutting cylinder), bed knife (bottom blade), and groomer blades are all edged tools. Handle them carefully, since they could cut your hands and feet.

1. Adjust the height of groomer.
2. Loosen the pipe with adjustment screw and adjust it so that the length of the groomer spring is approximately 45.0 mm (1.77 in).

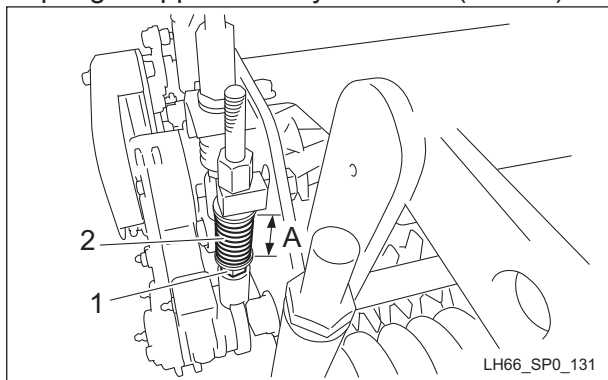

Adjustment of Groomer Spring\_001

1	Pipe with adjustment screw
2	Groomer spring
A	45.0 mm (1.77 in)

## Adjustment of CR brush

Adjustment of CR Brush (CR Brush Only Installation)

Note:  
Depending on the specifications, this function may not be available.

**Caution**

If the contact between the brush and the rear roller is too tight, the belt may slip or break.

**Important**

The rotating CR brush prevents grass clippings, etc., from attaching to the rear roller.

1. Loosen the left and right bolts and nuts used to install the CR brush.
2. Adjust the CR brush so that there is a clearance of 0 to 1.0 mm (0 to 0.039 in) between it and the rear roller, and then firmly tighten the loosened bolts and nuts.

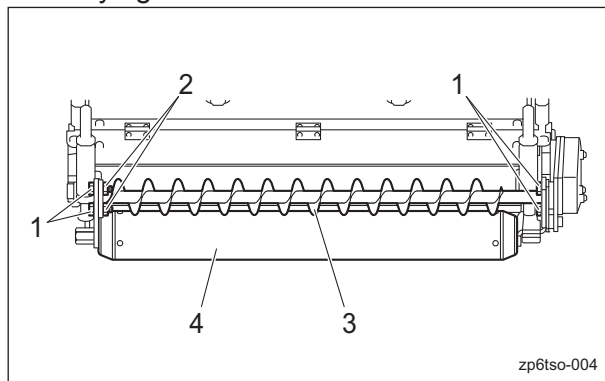

Adjustment of CR Brush (CR Brush Only Installation)\_001

1	Bolt
2	Nut
3	Brush
4	Rear roller

# Operating Machine and Mower Units

## Adjustment of CR Brush (installed together with Groomer)

**Note:**  
Depending on the specifications, this function may not be available.

**Caution**

If the contact between the brush and the rear roller is too tight, the belt may slip or break.

**Important**

The rotating CR brush prevents grass clippings, etc., from attaching to the rear roller.

1. Loosen the left and right bolts and nuts used to install the CR brush.
2. Adjust the CR brush so that there is a clearance of 0 to 1.0 mm (0 to 0.039 in) between it and the rear roller, and then firmly tighten the loosened bolts and nuts.

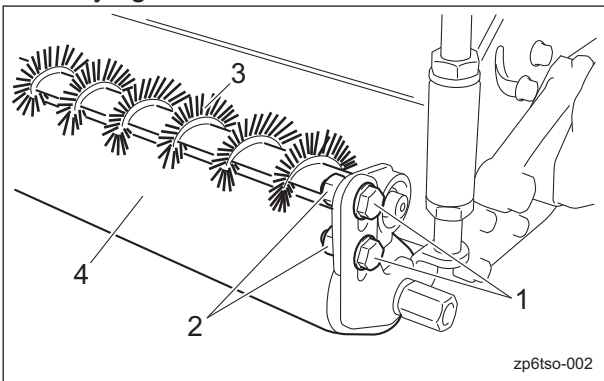

Adjustment of CR Brush (installed together with Groomer)\_001

1	Bolt
2	Nut
3	Brush
4	Rear roller

## Adjustment of Scraper

### Adjustment of Front Scraper

**Note:**  
Depending on the specifications, this function may not be available.

**Caution**

If the contact between the scraper and the front roller is too tight, the scraper may become deformed or the front roller may be shaved.

The scraper prevents grass clippings, etc., from attaching to the front roller.

1. Loosen the left and right bolts and nuts of the scraper.

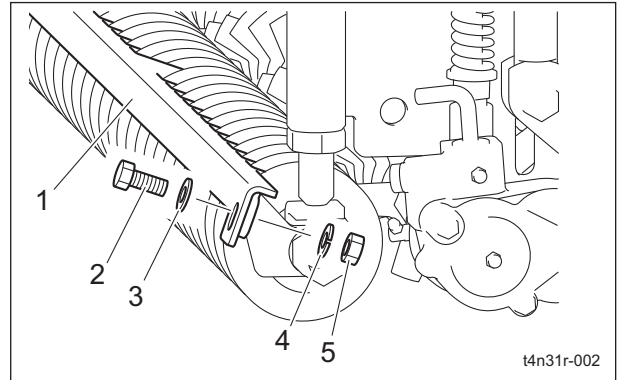

Adjustment of Front Scraper\_001

1	Scraper
2	Bolt
3	Washer
4	Spring washer
5	Nut

2. Adjust the scraper so that there is a clearance of 2.0 to 3.0 mm (0.079 to 0.118 in) between it and the outer diameter surface of the front roller, and then firmly tighten the loosened bolts and nuts.

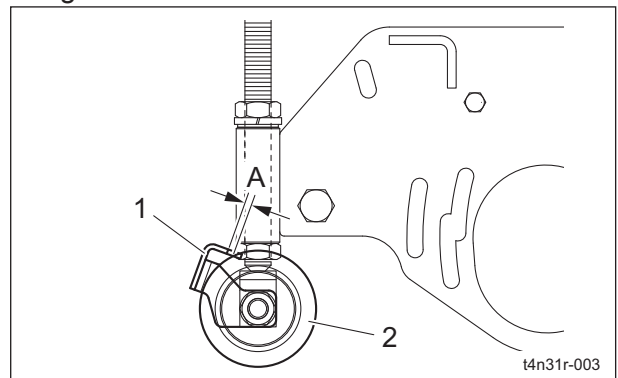

Adjustment of Front Scraper\_002

# Operating Machine and Mower Units

1	Scraper
2	Front roller
A	2.0 - 3.0 mm (0.079 - 0.118 in)

## Adjustment of Rear Scraper (Wire Type)

**Note:**  
Depending on the specifications, this function may not be available.

### ⚠ Caution

If the contact between the scraper and the rear roller is too tight, the scraper may break or sag.

The scraper prevents grass clippings, etc., from attaching to the rear roller.

1. Loosen the left and right lock nuts and nuts of the scraper.
2. Adjust the scraper so that there is a clearance of 2.0 to 3.0 mm (0.079 to 0.118 in) between it and the rear roller, and then secure it with the lock nuts.

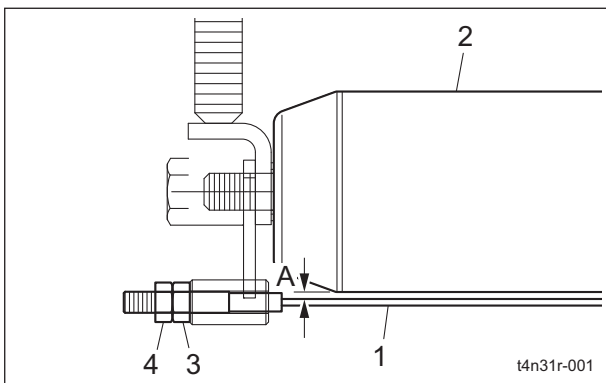

Adjustment of Rear Scraper (Wire Type)\_001

1	Scraper
2	Rear roller
3	Nut
4	Lock nut
A	2.0 - 3.0 mm (0.079 - 0.118 in)

## Adjustment of Belt Tension

### ⚠ Caution

Be sure to stop the engine before adjusting the belts.

### Important

Make sure that the belt has the specified amount of tension. Before making sure of its specified tension, rotate the belt several times.

If the belt becomes slack due to frequent use, it may jump or slip.

In addition, if it is overtightened, it may wear prematurely.

If necessary, adjust it, and always check the belt for appropriate tension.

## CR Brush Drive Belt (Installation with only CR Brush)

**Note:**  
Depending on the specifications, this function may not be available.

### ⚠ Caution

Be sure to stop the engine before adjusting the belts.

1. Remove the belt cover.
2. Check the belt tension.
3. If the belt tension is inappropriate, adjust the belt tension with the tension pulley adjustment bolt.

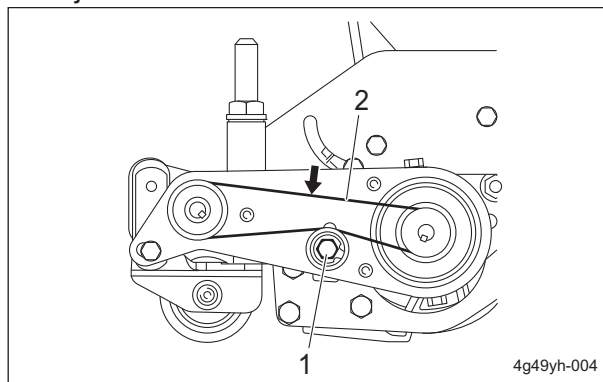

CR Brush Drive Belt (Installation with only CR Brush)\_001

1	Tension pulley adjustment bolt
2	Belt

# Operating Machine and Mower Units

The belt tension is appropriate when the belt slacks by approximately 5.0 to 6.0 mm (0.197 to 0.236 in) when you apply a force of 10.0 N (1.0 kgf) with your finger to the belt at the middle point between the pulleys.

CR Brush Drive Belt (Installation with Groomer at the same time)

**Note:**  
Depending on the specifications, this function may not be available.

**⚠ Caution**

Be sure to stop the engine before adjusting the belts.

1. Remove the belt cover.
2. Check the belt tension.
3. If the belt tension is inappropriate, move the bolt to adjust the belt tension.

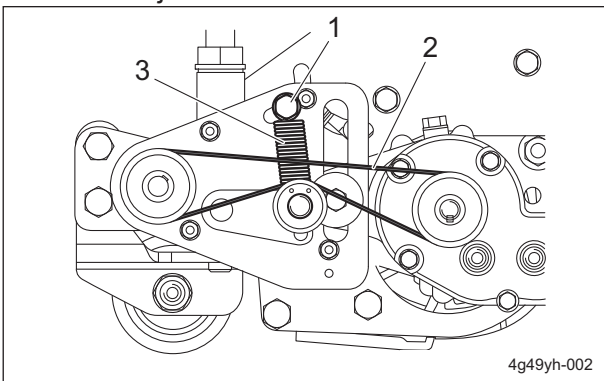

CR Brush Drive Belt (Installation with Groomer at the same time)\_001

1	Bolt
2	Belt
3	Spring

The belt tension is appropriate when the length of the spring coil is 63.0 to 65.0 mm (2.48 to 2.56 in).

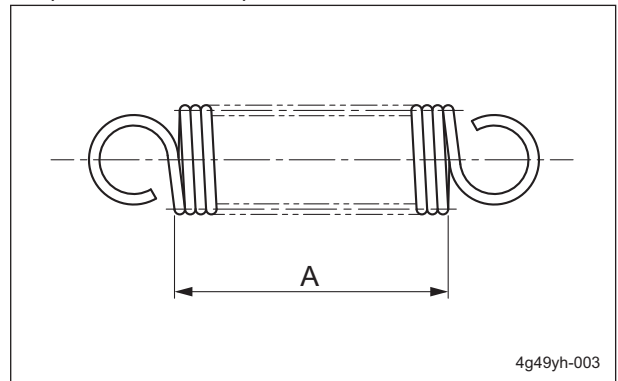

CR Brush Drive Belt (Installation with Groomer at the same time)\_002

A	63.0 - 65.0 mm (2.48 - 2.56 in)
---	---------------------------------

# Operating Machine and Mower Units

## Removal and installation of each section

### Reel cover

#### Removal of Reel Cover

**⚠ Danger**

Both the reel cutter (cutting cylinder) and the bed knife (bottom blade) are edged tools. Handle them carefully, since they could cut your hands and feet.

1. Turn up the mower units.

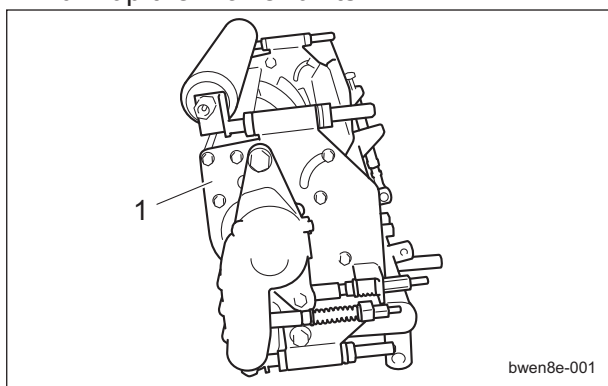

Removal of Reel Cover\_001

1	Mower unit
---	------------

2. Remove the rear roller Assy.  
"Removal of the Rear Roller Assy" (Page 4-26)
3. Remove the three bolts, spring washers and washers used to install the reel cover on each of the left and right sides, and then remove it from the mower unit.

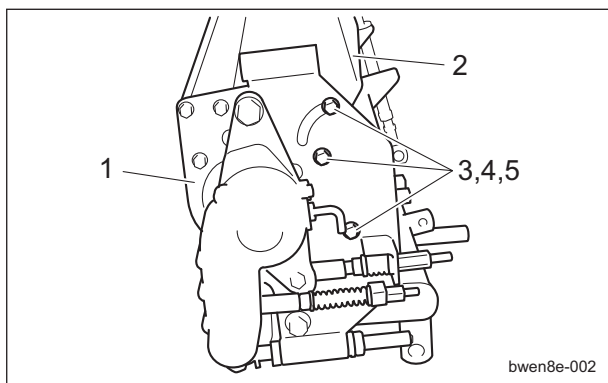

Removal of Reel Cover\_002

1	Mower unit
2	Reel cover
3	Bolt
4	Spring washer
5	Washer

4. Lift up the reel cover in the direction of the arrow from the mower unit to remove it.

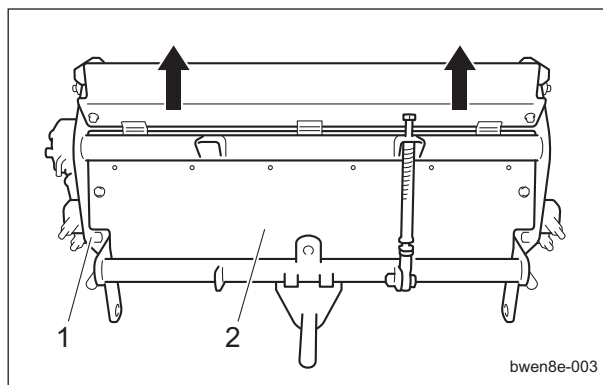

Removal of Reel Cover\_003

1	Mower unit
2	Reel cover

#### Installation of Reel Cover

**⚠ Danger**

Both the reel cutter (cutting cylinder) and the bed knife (bottom blade) are edged tools. Handle them carefully, since they could cut your hands and feet.

**⚠ Caution**

"Tightening torques" (Page 3-5) See the list. Note that the Baroness product warranty may not apply to defects caused by incorrect or overtorque tightening, etc.

For installation, reverse the removing procedure.

# Operating Machine and Mower Units

## Bed Knife Mounting Assy

### Removal of Bed Knife Base Assy

**⚠ Danger**

Both the reel cutter (cutting cylinder) and the bed knife (bottom blade) are edged tools. Handle them carefully, since they could cut your hands and feet.

**⚠ Caution**

When placing the mower unit on top of pieces of wood, check thoroughly that the mower unit is stable.

**⚠ Caution**

When removing the bed knife base assy from the mower unit, take care not to drop it and cause injury as it is heavy.

**⚠ Caution**

Be sure to hold the bed knife base assy firmly when removing bolts and nuts.

1. Remove the mower unit.
2. Turn the mower unit upside-down.
3. Place pieces of wood under the left and right front roller brackets, and place the mower unit on top.
4. Tighten the cutter adjustment nut, and make some space between the reel cutter and the bed knife.

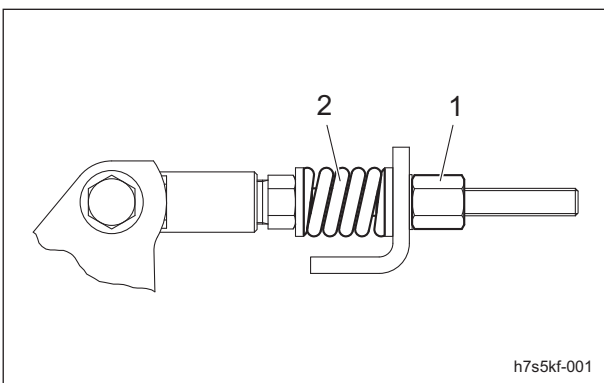

Removal of Bed Knife Base Assy\_001

1	Cutter adjustment nut
2	Spring

5. Loosen the left and right bolts used to install the bed knife base.

6. Remove the bolts and disc spring washers on the reel housing side.
7. Remove the bolts and disc spring washers on the hydraulic housing side.

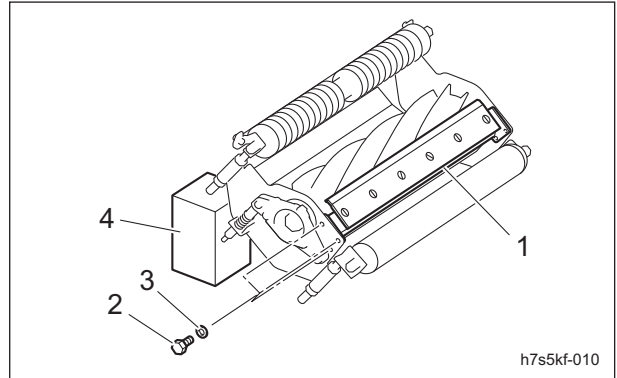

Removal of Bed Knife Base Assy\_002

1	Bed knife base
2	Bolt
3	Disc spring washer
4	Piece of wood

8. Lift up the bed knife base, and then pull out it keeping its horizontal attitude to remove it from the mower unit.

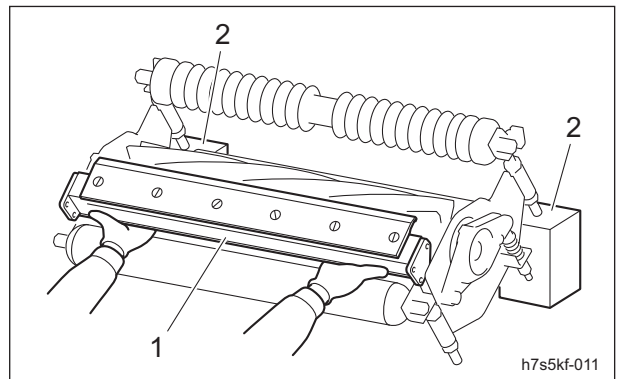

Removal of Bed Knife Base Assy\_003

1	Bed knife base
2	Piece of wood

# Operating Machine and Mower Units

## Installation of Bed Knife Base Assy

### **⚠ Danger**

Both the reel cutter (cutting cylinder) and the bed knife (bottom blade) are edged tools. Handle them carefully, since they could cut your hands and feet.

### **⚠ Caution**

When placing the mower unit on top of pieces of wood, check thoroughly that the mower unit is stable.

### **⚠ Caution**

"Tightening torques" (Page 3-5) See the list. Note that the Baroness product warranty may not apply to defects caused by incorrect or overtightening, etc.

### **⚠ Caution**

When handling the reel cutter or bed knife, wear gloves to protect your hands. Pay attention not to let the reel cutter (cutting cylinder) catch your gloves during your rotating it. Otherwise, you may injure your hand or fingers.

1. Place pieces of wood under the left and right front roller brackets, and place the mower unit on top.
2. Insert the bed knife base horizontally into the mower unit.  
Note:  
If you cannot insert it by hand, tap it lightly with a plastic hammer.  
Do not allow the reel cutter to come in contact with the bed knife.

3. Temporarily install the left and right bolts and disc spring washers used to install the bed knife mounting.

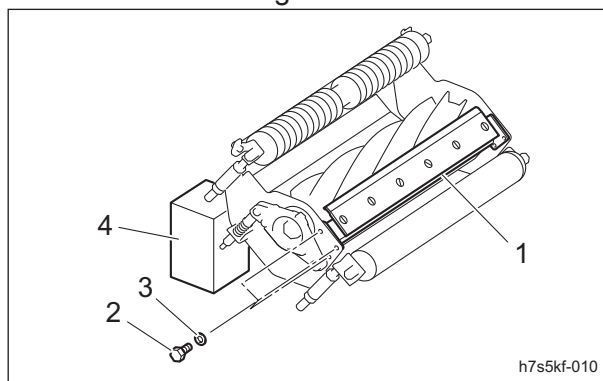

Installation of Bed Knife Base Assy\_001

1	Bed knife base
2	Bolt
3	Disc spring washer
4	Piece of wood

4. Tighten the bolts on both sides of the reel housing.
5. Adjust blade engagement.  
"Adjustment of Blade Engagement" (Page 4-7)
6. Adjust it by using the pipe with cutter adjusting screw so that the length of the spring coil will be approximately 27.0 mm (1.06 in).

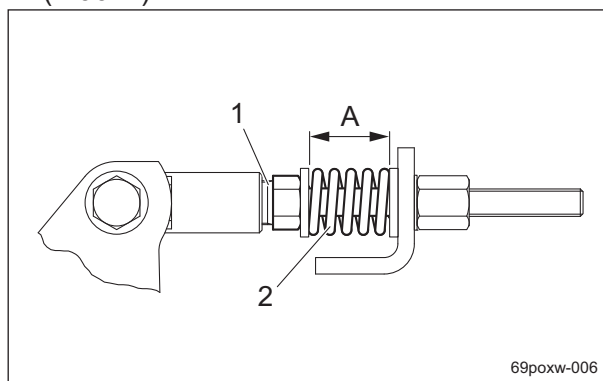

Installation of Bed Knife Base Assy\_002

1	Pipe with cutter adjustment screw
2	Cutter adjustment spring
A	27.0 mm (1.06 in)

7. Adjust the cutting height.  
"Cutting Height Adjustment" (Page 4-8)

# Operating Machine and Mower Units

## Bed knife

### Removal of Bed Knife

**Caution**

Both the reel cutter (cutting cylinder) and the bed knife (bottom blade) are edged tools. Handle them carefully, since they could cut your hands and feet.

**Caution**

If removing the bed knife base assy from the mower unit, take care not to drop it and cause injury as it is heavy.

1. Remove the bed knife base assy. "Removal of Bed Knife Base Assy" (Page 4-16)
2. Place the bed knife base assy on a stable stage.
3. Remove the screws using an impact driver or punch, and then remove the bed knife from the bed knife base.

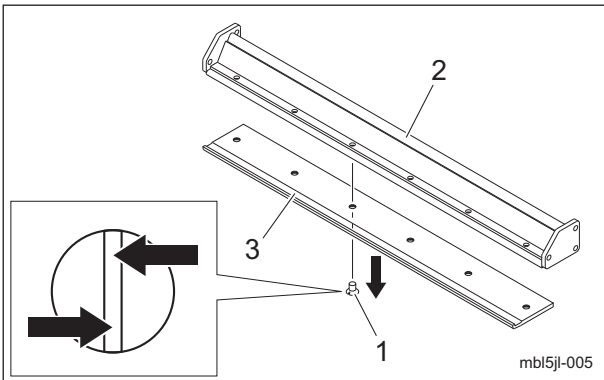

Removal of Bed Knife\_001

1	Screw
2	Bed knife base
3	Bed knife

### Installation of Bed Knife

**Caution**

Both the reel cutter (cutting cylinder) and the bed knife (bottom blade) are edged tools. Handle them carefully, since they could cut your hands and feet.

**Caution**

"Tightening torques" (Page 3-5) See the list. Note that the Baroness product warranty may not apply to defects caused by incorrect or overtorque tightening, etc.

**Important**

Be careful not to damage the knife mounting surface of bed knife base. Clean off any rust or dirt.

**Important**

Replace the screws with new ones.

1. Tighten the screws evenly using an impact driver, and install the bed knife to the bed knife base.

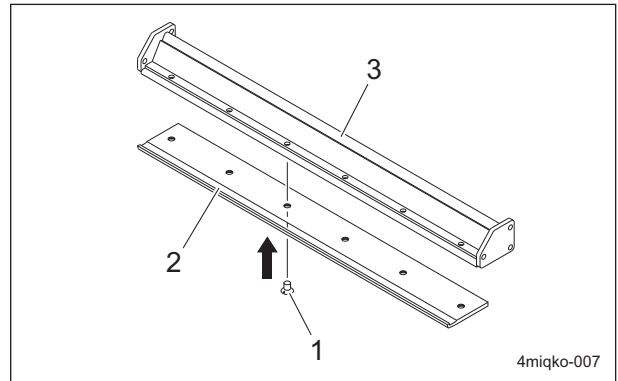

Installation of Bed Knife\_001

1	Screw
2	Bed knife
3	Bed knife base

# Operating Machine and Mower Units

**Note:**

When installing the bed knife, first tighten the center screw, and then tighten from center outwards, alternating between left and right sides.

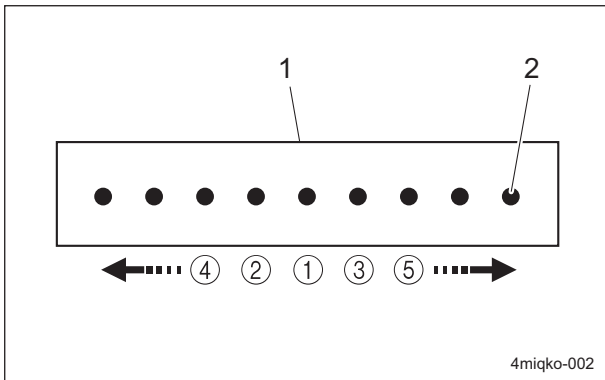

4miqko-002

Installation of Bed Knife\_002

1	Bed knife
2	Screw

1	Bolt
2	Spring washer
3	Reel housing lid
4	Packing
5	Mower weight

- Secure the reel cutter with a wooden board.
- Loosen the left and right special nuts with a socket wrench or similar tool.

**Note:**

Socket wrench size 41 mm

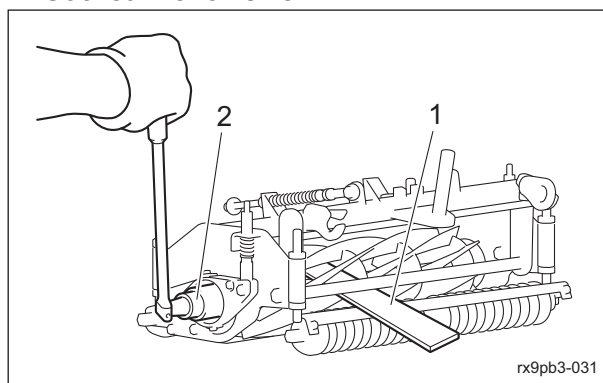

rx9pb3-031

Removal of Reel Cutter\_002

1	Wood board
2	Socket wrench

## Reel Cutter

### Removal of Reel Cutter



**Caution**

Both the reel cutter (cutting cylinder) and the bed knife (bottom blade) are edged tools. Handle them carefully, since they could cut your hands and feet.

- Remove the bed knife base assy. "Removal of Bed Knife Base Assy" (Page 4-16)
- Remove the bolt and spring washer.
- Remove the reel housing lid, mower weight and packing.

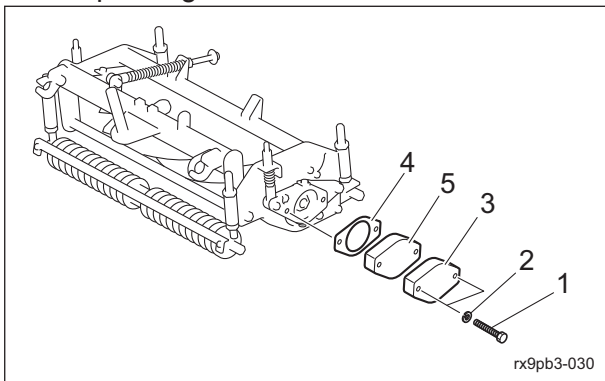

rx9pb3-030

Removal of Reel Cutter\_001

- Remove the left and right special nuts.

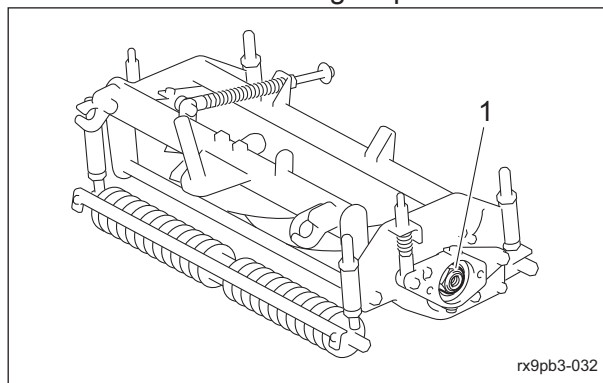

rx9pb3-032

Removal of Reel Cutter\_003

1	Special nut
---	-------------



**Caution**

When placing the mower unit on top of pieces of wood, check thoroughly that the mower unit is stable.

- Turn the mower unit upside-down.
- Place pieces of wood under the left and right front roller brackets, and place the mower unit on top.

# Operating Machine and Mower Units

9. Remove the cutter adjustment nut, washer and spherical washer.

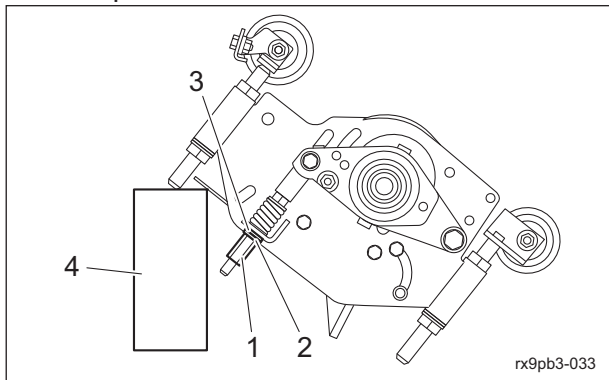

Removal of Reel Cutter\_004

1	Nut
2	Washer
3	Spherical washer
4	Piece of wood

12. Remove the nuts fixing the left and right reel housings, and then remove the washers and spindle bolts.

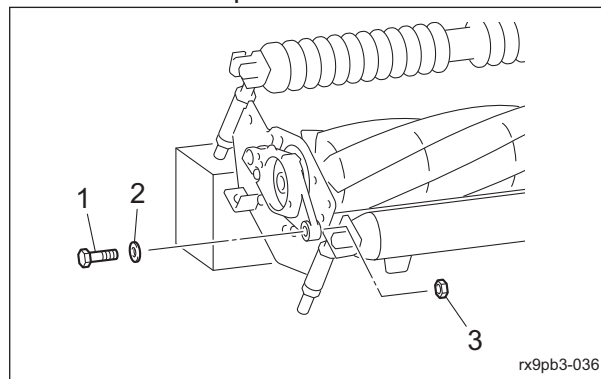

Removal of Reel Cutter\_007

1	Spindle bolt
2	Washer
3	Nut

10. Remove the left and right housing bolts, nuts, and washers.

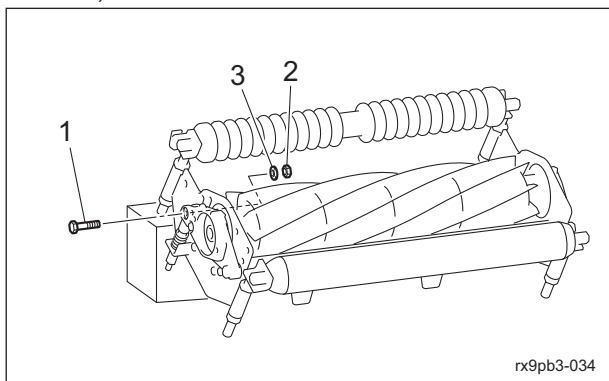

Removal of Reel Cutter\_005

1	Housing bolt
2	Nut
3	Washer

13. To remove the reel housing, install the sliding hammer mounting bracket to the reel housing, using a sliding hammer.

14. Install bolts A using the  $\phi 10$  holes of the mounting bracket.

15. Install the sliding hammer with bolt B and nut.

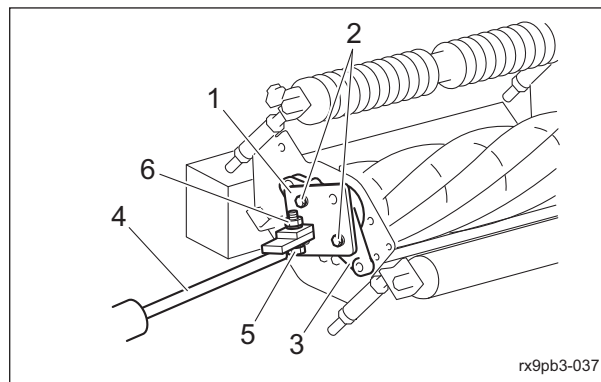

Removal of Reel Cutter\_008

1	Mounting bracket
2	Bolt A
3	Housing
4	Sliding hammer
5	Bolt B
6	Nut

11. Remove the left and right cutter adjustment parts.

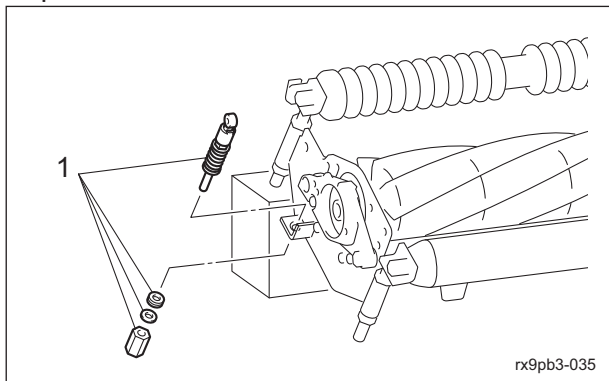

Removal of Reel Cutter\_006

1	Cutter adjustment parts
---	-------------------------

# Operating Machine and Mower Units

**⚠ Caution**

When sliding the hammer, be careful of the holding position not to pinch your fingers.

- Slide the hammer and remove the reel housing by its impact.

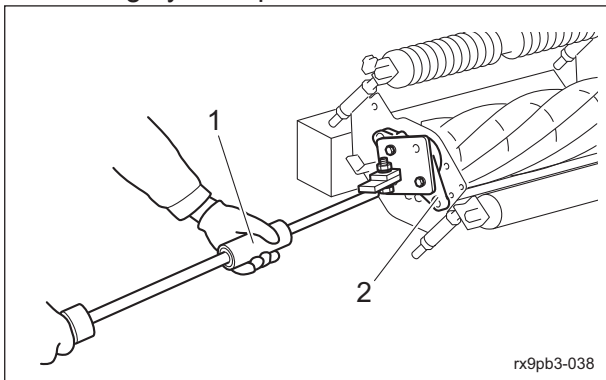

Removal of Reel Cutter\_009

1	Hammer
2	Reel Housing

- Follow the same steps to remove the reel housing of the other side.
- Lift the end of the reel cutter and the other end to remove from the mower unit.

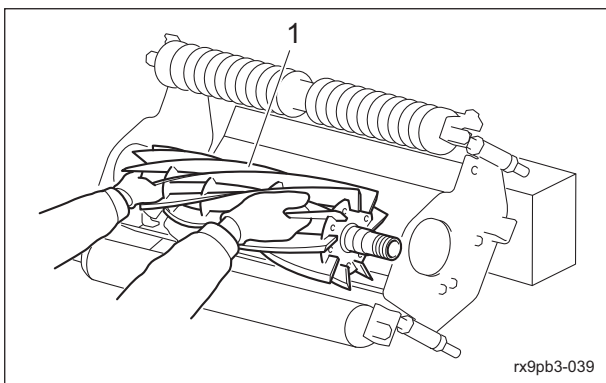

Removal of Reel Cutter\_010

1	Reel cutter
---	-------------

## Attaching Reel Cutter (Cutting Cylinder)

**⚠ Caution**

Both the reel cutter (cutting cylinder) and the bed knife (bottom blade) are edged tools. Handle them carefully, since they could cut your hands and feet.

**⚠ Caution**

"Tightening torques" (Page 3-5) See the list. Note that the Baroness product warranty may not apply to defects caused by incorrect or overtorque tightening, etc.

- Turn the mower unit upside-down.
- Place the reel cutter in the reel unit in the correct direction.
- Lift the reel cutter up and insert the left and right reel housings into it.

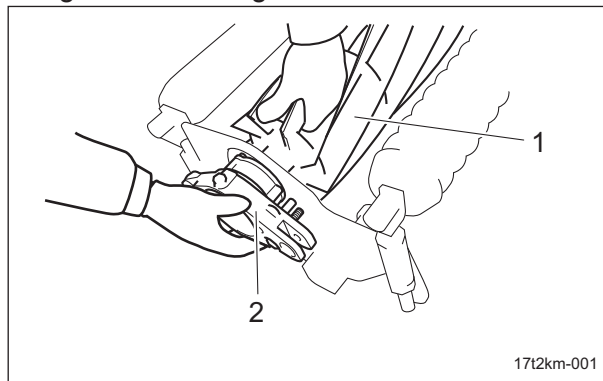

Attaching Reel Cutter (Cutting Cylinder)\_001

1	Reel cutter
2	Reel housing

- Tap the left and right reel housings with a plastic hammer.

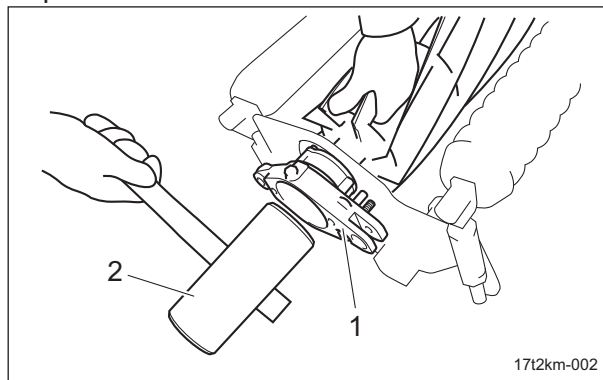

Attaching Reel Cutter (Cutting Cylinder)\_002

1	Reel housing
2	Plastic hammer

# Operating Machine and Mower Units

**⚠ Caution**

When placing the mower unit on top of pieces of wood, check thoroughly that the mower unit is stable.

- Place pieces of wood under the left and right front roller brackets, and place the mower unit on top.
- Temporarily install the spindle bolts, washers, and nuts of the left and right reel housings.

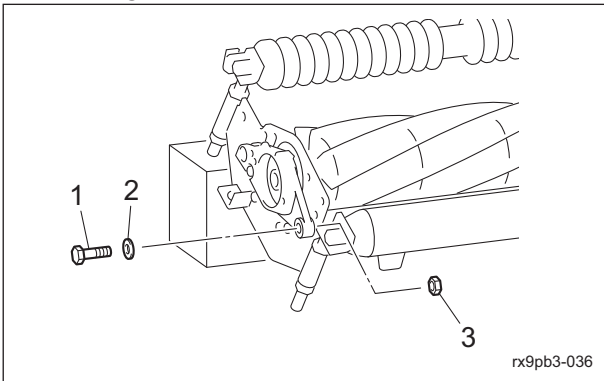

Attaching Reel Cutter (Cutting Cylinder)\_003

1	Spindle bolt
2	Washer
3	Nut

- Use the bearing driver to tap the left and right reel housings with a plastic hammer until there is no play between the housings and frame.

**Note:**

If there is play between the frame and reel housing, tap the reel housing on one side so that there is no play between the frame and reel housing.

- Install all of the left and right cutter adjustment parts.

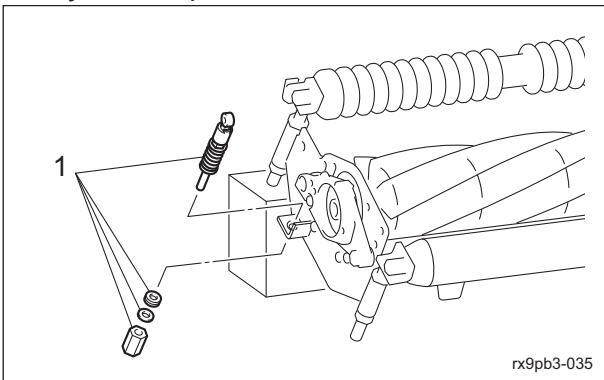

Attaching Reel Cutter (Cutting Cylinder)\_004

1	Cutter adjustment parts
---	-------------------------

- Install the left and right housing bolts, nuts, and washers.

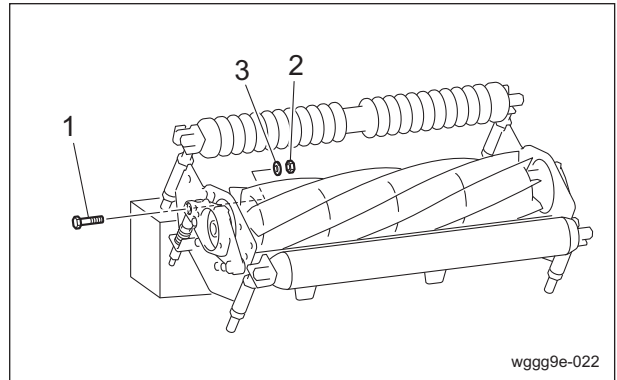

Attaching Reel Cutter (Cutting Cylinder)\_005

1	Housing bolt
2	Nut
3	Washer

- Loosen the temporarily tightened left and right spindle bolts in a way such that the reel housing moves but there is no play, and then lock them with nuts.

- Install the left and right special nuts.

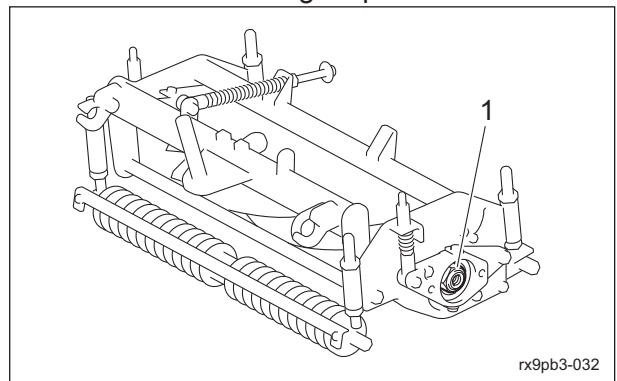

Attaching Reel Cutter (Cutting Cylinder)\_006

1	Special nut
---	-------------

- Secure the reel cutter with a wooden board.

# Operating Machine and Mower Units

13. Loosen the left and right special nuts with a socket wrench or similar tool.

Note:

Socket wrench size 41 mm

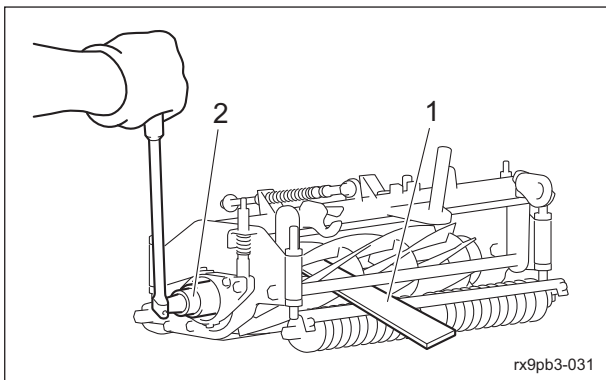

Attaching Reel Cutter (Cutting Cylinder)\_007

1	Wood board
2	Socket wrench

14. Install the reel housing lid, mower weight and packing with a bolt and spring washer.

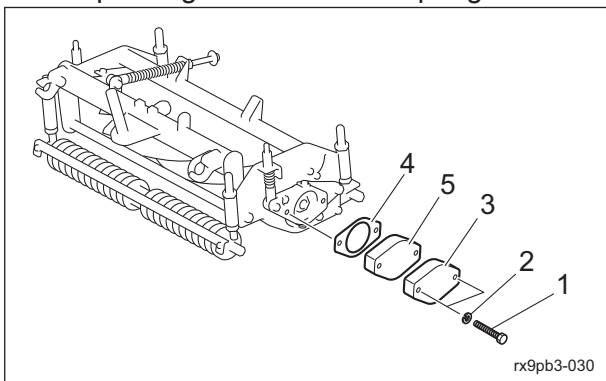

Attaching Reel Cutter (Cutting Cylinder)\_008

1	Bolt
2	Spring washer
3	Reel housing lid
4	Packing
5	Mower weight

15. Tighten the cutter adjustment nut so that there is no clearance with the cutter adjustment spring.

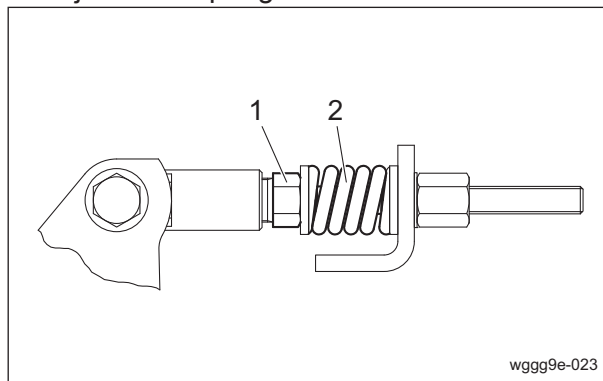

Attaching Reel Cutter (Cutting Cylinder)\_009

1	Cutter adjustment nut
2	Cutter adjustment spring

16. Install the bed knife base assy.  
"Installation of Bed Knife Base Assy" (Page 4-17)

17. Adjust blade engagement.  
"Adjustment of Blade Engagement" (Page 4-7)

18. Loosen the pipe with cutter adjustment screw and adjust it so that the length of the spring coil is approximately 27.0 mm (1.06 in).

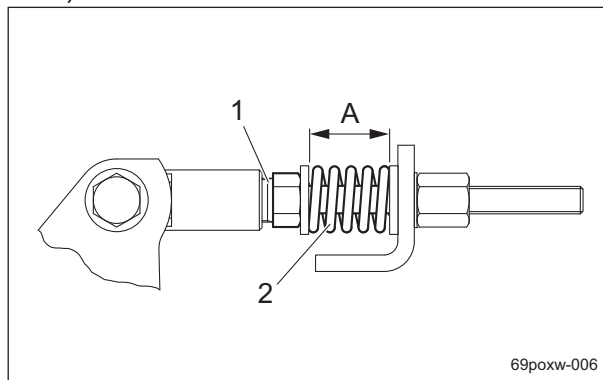

Attaching Reel Cutter (Cutting Cylinder)\_010

1	Pipe with cutter adjustment screw
2	Cutter adjustment spring
A	27.0 mm (1.06 in)

19. Adjust the cutting height.  
"Cutting Height Adjustment" (Page 4-8)

# Operating Machine and Mower Units

## Front Roller Assy

### Removal of Front Roller Assy

**Caution**

Both the reel cutter (cutting cylinder) and the bed knife (bottom blade) are edged tools. Handle them carefully, since they could cut your hands and feet.

**Caution**

When placing the mower unit on top of pieces of wood, check thoroughly that the mower unit is stable.

**Important**

When turning the mower unit upside down and placing the cutter adjustment bolt on a piece of wood, handle the cutter adjustment bolt carefully as there is the risk of it being damaged.

1. Remove the mower unit.
2. Turn the mower unit upside-down.
3. Place pieces of wood under the left and right cutter adjustment bolts, and place the mower unit on top.

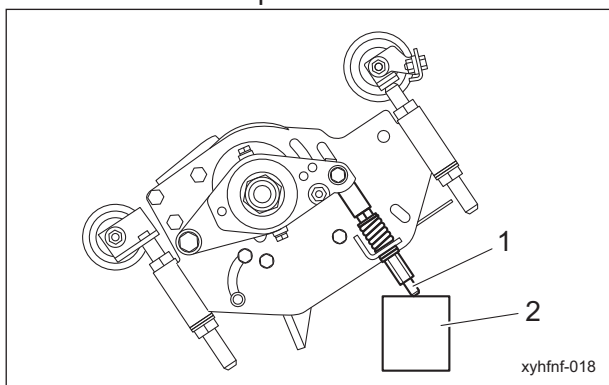

Removal of Front Roller Assy\_001

1	Cutter adjustment bolt
2	Piece of wood

### 4. Remove the scraper.

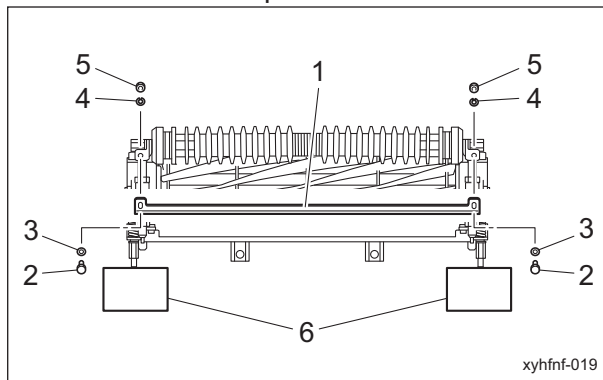

Removal of Front Roller Assy\_002

1	Scraper
2	Bolt
3	Washer
4	Spring washer
5	Nut
6	Piece of wood

### 5. Loosen the nuts, spring washers and washers that tighten the left and right cutting height adjustment screws of the front roller assy.

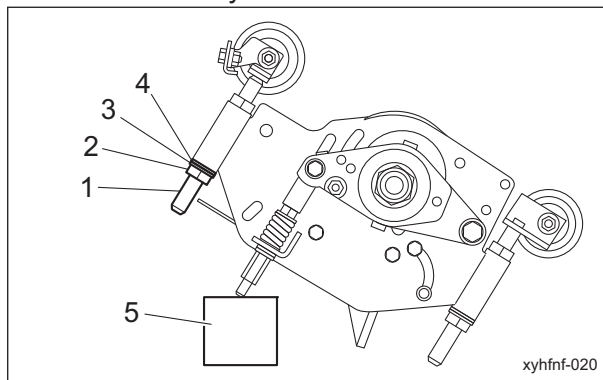

Removal of Front Roller Assy\_003

1	Cutting height adjustment screw
2	Nut
3	Spring washer
4	Washer
5	Piece of wood

# Operating Machine and Mower Units

6. Raise the front roller with both hands and pull it out horizontally with the cutting height adjustment screw installed to remove the roller from the mower unit.

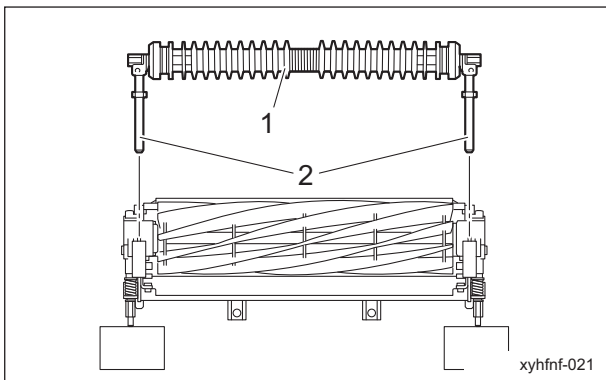

Removal of Front Roller Assy\_004

1	Front roller assy
2	Cutting height adjustment screw

7. Remove the left and right nuts A, spring washers, scraper mounting brackets and cutting height adjustment screws from the front roller assy.

8. Remove nuts B from the cutting height adjustment screws.

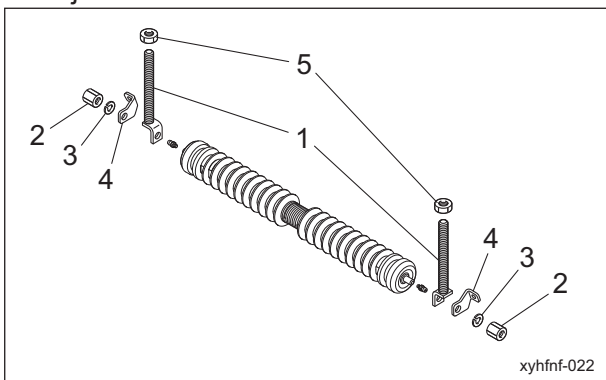

Removal of Front Roller Assy\_005

1	Cutting height adjustment screw
2	Nut A
3	Spring washer
4	Scraper mounting bracket
5	Nut B

## Installation of Front Roller Assy

**Caution**

Both the reel cutter (cutting cylinder) and the bed knife (bottom blade) are edged tools. Handle them carefully, since they could cut your hands and feet.

**Caution**

"Tightening torques" (Page 3-5) See the list. Note that the Baroness product warranty may not apply to defects caused by incorrect or overtorque tightening, etc.

1. For installation, reverse the removing procedure.
2. Rotate the front roller by hand to check the rotation state.
3. Set the gap between the scraper and front roller so that they do not come into contact.
4. Adjust the cutting height.  
"Cutting Height Adjustment" (Page 4-8)

# Operating Machine and Mower Units

## Rear Roller Assy

### Removal of the Rear Roller Assy

**Caution**

Both the reel cutter (cutting cylinder) and the bed knife (bottom blade) are edged tools. Handle them carefully, since they could cut your hands and feet.

**Caution**

When placing the mower unit on top of pieces of wood, check thoroughly that the mower unit is stable.

1. Remove the mower unit.
2. Turn the mower unit upside-down.
3. Place a piece of wood under the frame, and place the mower unit on top.
4. Loosen the nuts, spring washers and washers that tighten the left and right cutting height adjustment screws of the rear roller assy.

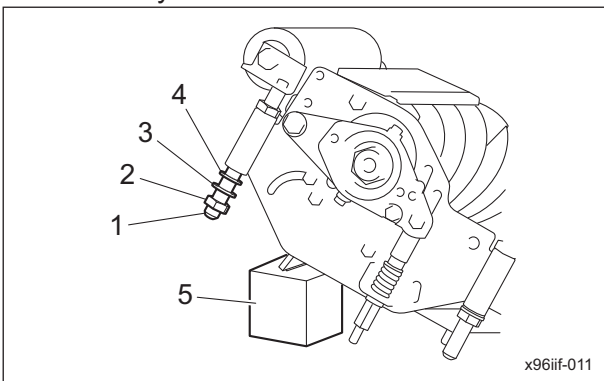

Removal of the Rear Roller Assy\_001

1	Cutting height adjustment screw
2	Nut
3	Spring washer
4	Washer
5	Piece of wood

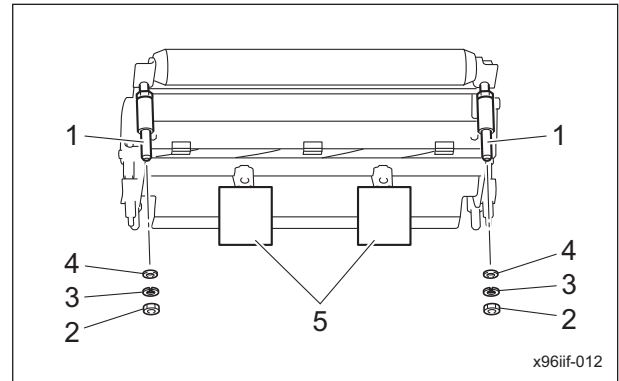

Removal of the Rear Roller Assy\_002

1	Cutting height adjustment screw
2	Nut
3	Spring washer
4	Washer
5	Piece of wood

5. Raise the rear roller and pull it out horizontally with the cutting height adjustment screw installed to remove the roller from the mower unit.

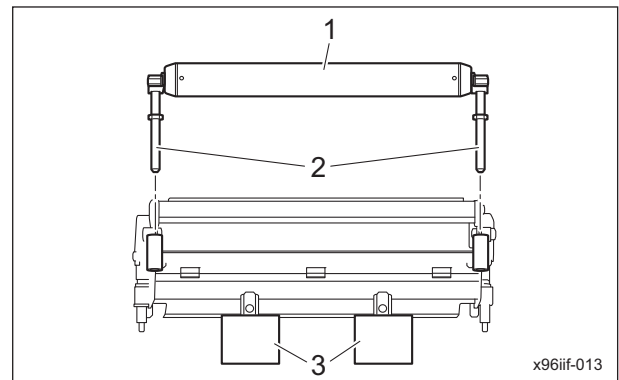

Removal of the Rear Roller Assy\_003

1	Rear roller assy
2	Cutting height adjustment screw
3	Piece of wood

6. Remove the left and right nuts A, spring washers, cutting height adjustment screws, and grease nipples from the rear roller assy.

# Operating Machine and Mower Units

7. Remove nuts B from the cutting height adjustment screws.

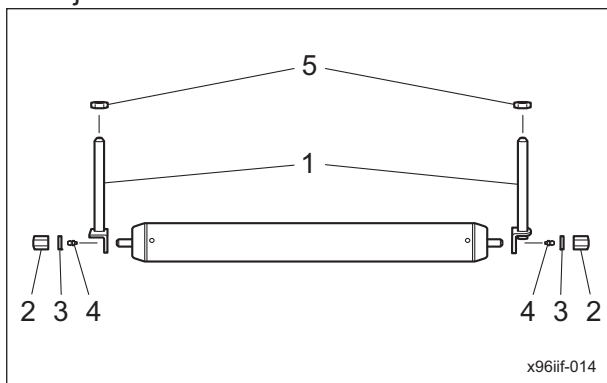

Removal of the Rear Roller Assy\_004

1	Cutting height adjustment screw
2	Nut A
3	Spring washer
4	Grease nipple
5	Nut B

Reference:

The illustration is of the cutting height adjustment screw (installed on right of motor). The cutting height adjustment screw (installed on left of motor) is installed at opposite end.

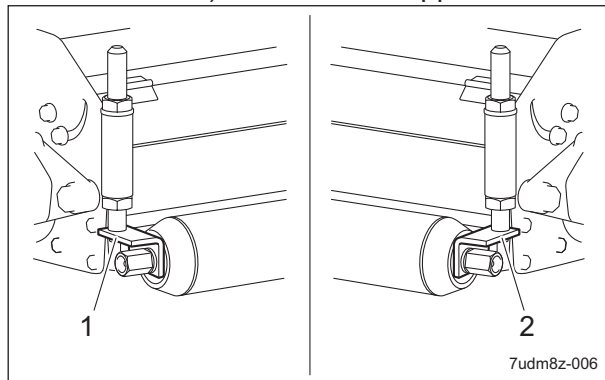

Installation of Rear Roller Assy\_001

1	Left cutting height adjustment screw
2	Right cutting height adjustment screw

## Installation of Rear Roller Assy

### ⚠ Caution

Both the reel cutter (cutting cylinder) and the bed knife (bottom blade) are edged tools. Handle them carefully, since they could cut your hands and feet.

### ⚠ Caution

"Tightening torques" (Page 3-5) See the list. Note that the Baroness product warranty may not apply to defects caused by incorrect or overtightening, etc.

### Important

The left and right height adjustment screws are different from each other. The installation position of types with a CR brush installed may differ depending on the mower unit. Install it in the correct orientation.

1. For installation, reverse the removing procedure.
2. Turn the rear roller by hand and confirm how it turns.
3. Adjust the cutting height.  
"Cutting Height Adjustment" (Page 4-8)

## Groomer Case Assy

Removal of Groomer Case Assy (type with only groomer installed)

Note:

Depending on the specifications, this function may not be available.

### ⚠ Caution

The reel cutter (cutting cylinder), bed knife (bottom blade), and groomer blades are all edged tools. Handle them carefully, since they could cut your hands and feet.

### ⚠ Caution

When placing the mower unit on top of pieces of wood, check thoroughly that the mower unit is stable.

1. Remove the mower unit.
2. Turn the mower unit upside-down.

# Operating Machine and Mower Units

3. Place a piece of wood under the front roller adjustment screw, and place the mower unit on top.

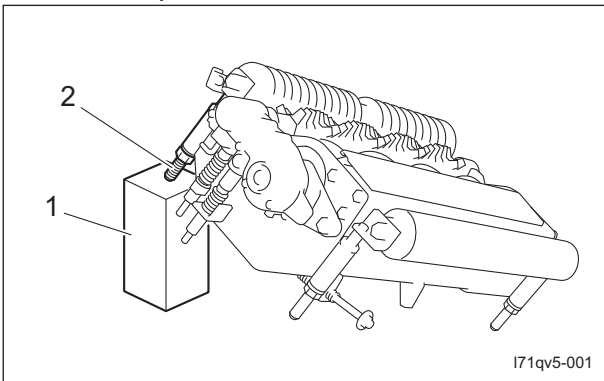

Removal of Groomer Case Assy (type with only groomer installed)\_001

1	Piece of wood
2	Front roller adjustment screw

4. Remove the stop bolts and seal washers from the reel housing.

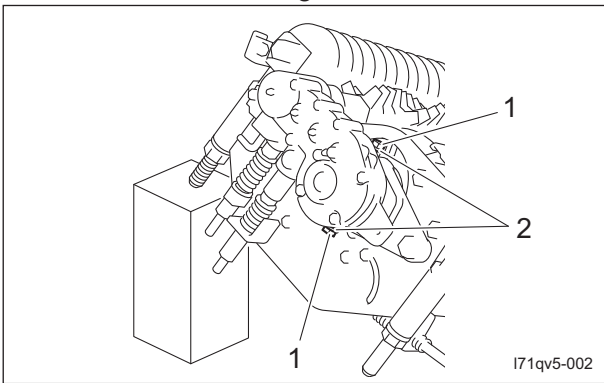

Removal of Groomer Case Assy (type with only groomer installed)\_002

1	Stop bolt
2	Seal washer

5. Remove the U nut and washer A used to install the groomer housing.

6. Remove the nut, spring washer and washer B securing the groomer adjustment bolt Assy.

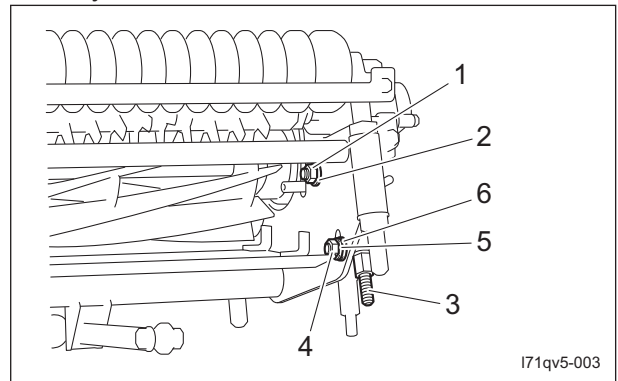

Removal of Groomer Case Assy (type with only groomer installed)\_003

1	U nut
2	Washer A
3	Groomer adjustment bolt
4	Nut
5	Spring washer
6	Washer B

7. Remove the groomer case assy in the direction of the arrow.

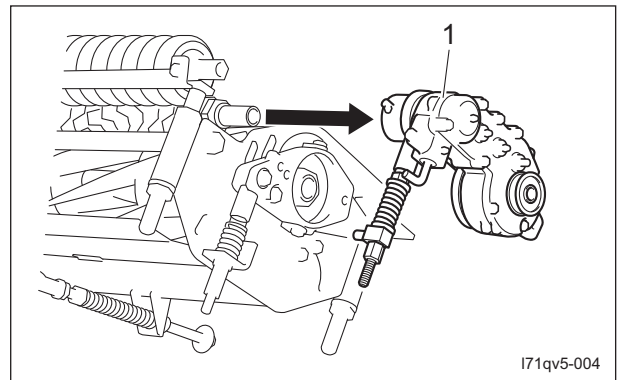

Removal of Groomer Case Assy (type with only groomer installed)\_004

1	Groomer case assy
---	-------------------

# Operating Machine and Mower Units

Removal of Groomer Case Assy (type with groomer + CR brush installed together)

**Note:**  
Depending on the specifications, this function may not be available.

**⚠ Caution**

The reel cutter (cutting cylinder), bed knife (bottom blade), and groomer blades are all edged tools. Handle them carefully, since they could cut your hands and feet.

**⚠ Caution**

When placing the mower unit on top of pieces of wood, check thoroughly that the mower unit is stable.

1. Remove the mower unit.
2. Remove the CR brush belt and then remove the brush mounting bracket.
3. Turn the mower unit upside-down.
4. Place a piece of wood under the front roller bracket, and place the mower unit on top.

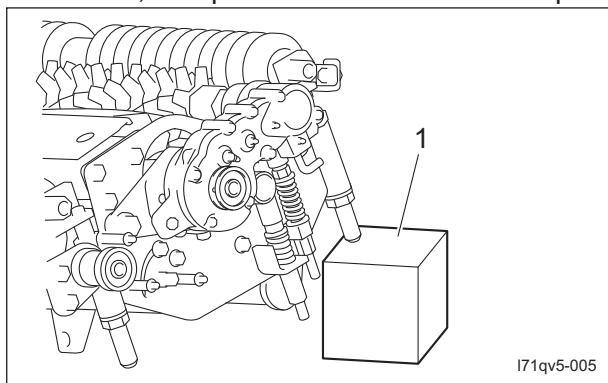

Removal of Groomer Case Assy (type with groomer + CR brush installed together)\_001

1	Block of wood
---	---------------

5. Remove the stop bolts and seal washers from the reel housing.

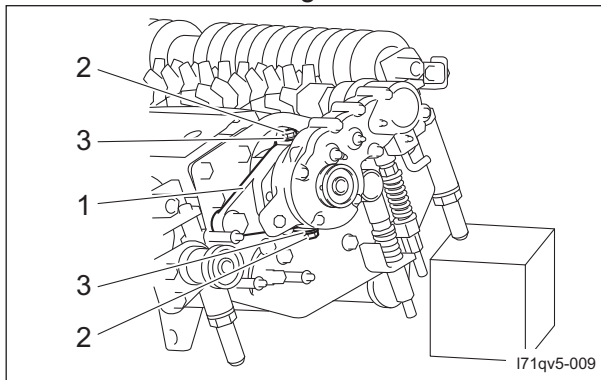

Removal of Groomer Case Assy (type with groomer + CR brush installed together)\_002

1	Reel housing
2	Stop bolt
3	Seal washer

6. Remove the hollow screws from the brush pulley.
7. Remove the brush pulley in the direction of the arrow.

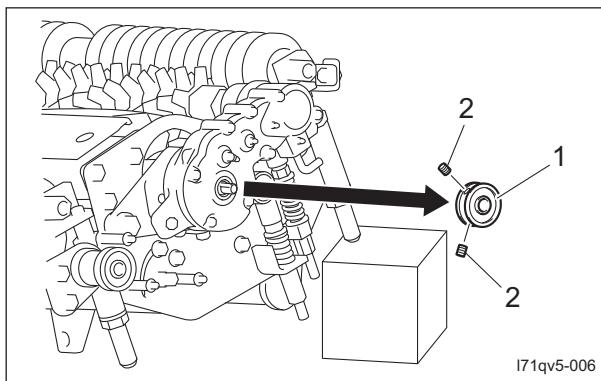

Removal of Groomer Case Assy (type with groomer + CR brush installed together)\_003

1	Brush pulley
2	Hollow screw

8. Remove the nut, spring washer and washer securing the groomer adjustment bolt assy.

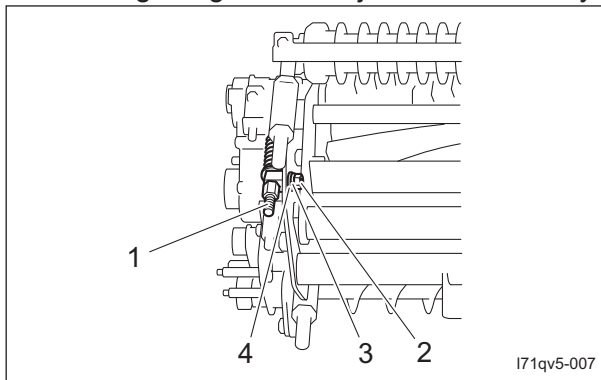

Removal of Groomer Case Assy (type with groomer + CR brush installed together)\_004

# Operating Machine and Mower Units

1	Groomer adjustment bolt assy
2	Nut
3	Spring washer
4	Washer

9. Remove the groomer case assy in the direction of the arrow.

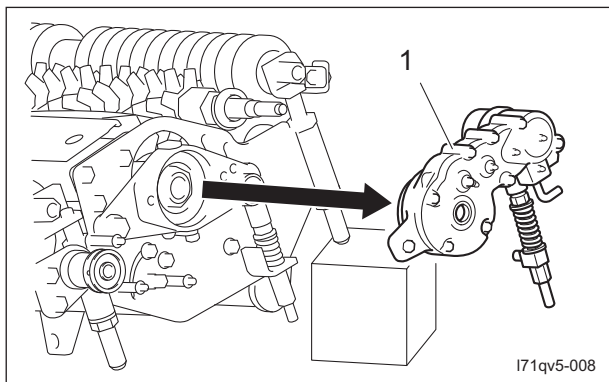

Removal of Groomer Case Assy (type with groomer + CR brush installed together)\_005

1	Groomer case assy
---	-------------------

## Installation of Groomer Case Assy

Note:  
Depending on the specifications, this function may not be available.

### ⚠ Caution

The reel cutter (cutting cylinder), bed knife (bottom blade), and groomer blades are all edged tools. Handle them carefully, since they could cut your hands and feet.

### ⚠ Caution

"Tightening torques" (Page 3-5) See the list. Note that the Baroness product warranty may not apply to defects caused by incorrect or overtightening, etc.

For installation, reverse the removing procedure.

## Groomer shaft assy

### Removal of Groomer Shaft Assy

Note:  
Depending on the specifications, this function may not be available.

### ⚠ Caution

The reel cutter (cutting cylinder), bed knife (bottom blade), and groomer blades are all edged tools. Handle them carefully, since they could cut your hands and feet.

### ⚠ Caution

When placing the mower unit on top of pieces of wood, check thoroughly that the mower unit is stable.

1. Remove the mower unit.
2. Turn the mower unit upside-down.
3. Place a piece of wood under the front roller adjustment screw, and place the mower unit on top.

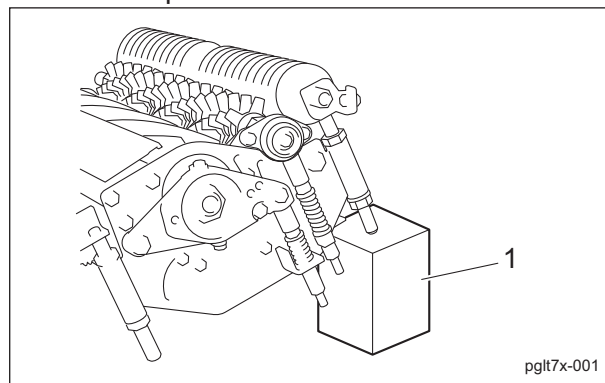

Removal of Groomer Shaft Assy\_001

1	Piece of wood
---	---------------

4. Remove the groomer case assy.

# Operating Machine and Mower Units

5. Loosen the left and right adjustment nuts of the groomer adjustment bolts so that there is no tension on the spring.

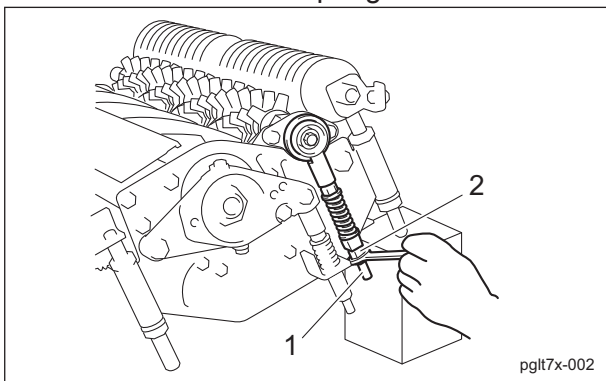

Removal of Groomer Shaft Assy\_002

1	Groomer adjustment bolt
2	Adjusting nut

6. Remove the left and right nuts, spring washer and washer securing the groomer adjustment bolt.

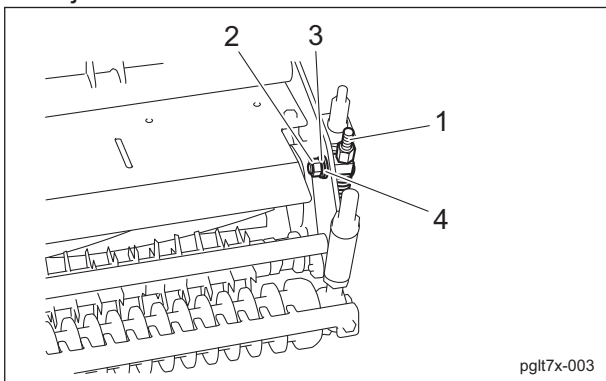

Removal of Groomer Shaft Assy\_003

1	Groomer adjustment bolt
2	Nut
3	Spring washer
4	Washer

7. Remove the groomer adjustment bolt from the groomer housing.

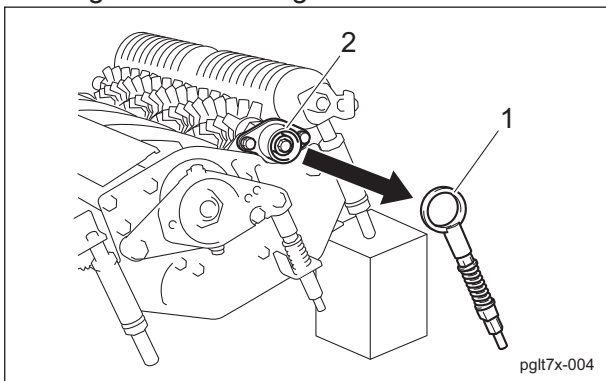

Removal of Groomer Shaft Assy\_004

1	Groomer adjustment bolt
2	Groomer housing

8. Remove the bolt, spring washer and washer from the groomer housing.

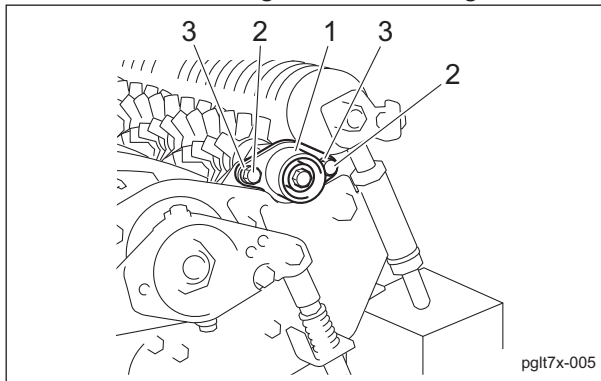

Removal of Groomer Shaft Assy\_005

1	Groomer housing
2	Bolt
3	Spring washer

9. Remove the groomer shaft assembly.

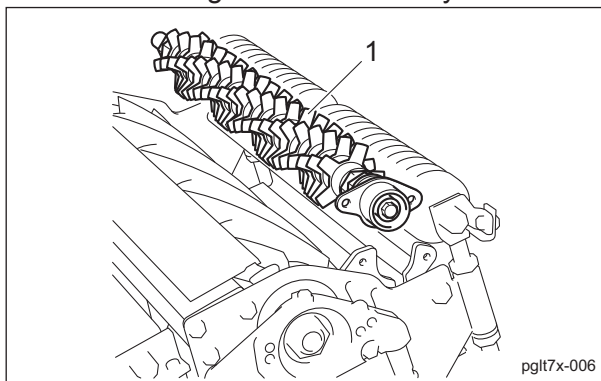

Removal of Groomer Shaft Assy\_006

1	Groomer shaft assembly
---	------------------------

10. Remove the bolt, spring washer and washer from the groomer shaft assembly.

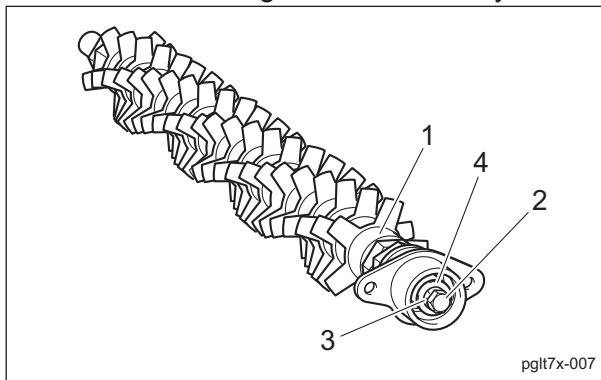

Removal of Groomer Shaft Assy\_007

Operating Machine and Mower Units

# Operating Machine and Mower Units

1	Groomer shaft assy
2	Bolt
3	Spring washer
4	Washer

11. Remove the groomer housing from the groomer shaft assy.

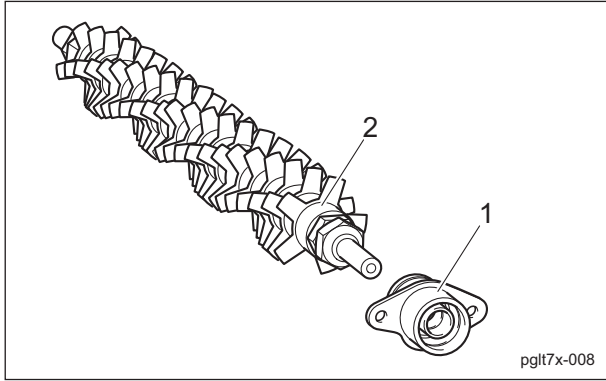

Removal of Groomer Shaft Assy\_008

1	Groomer housing
2	Groomer shaft assy

## Installation of Groomer Shaft Assy

Note:

Depending on the specifications, this function may not be available.

### Caution

The reel cutter (cutting cylinder), bed knife (bottom blade), and groomer blades are all edged tools. Handle them carefully, since they could cut your hands and feet.

### Caution

"Tightening torques" (Page 3-5) See the list. Note that the Baroness product warranty may not apply to defects caused by incorrect or overtorque tightening, etc.

1. For installation, reverse the removing procedure.
2. Adjust the groomer.  
"Adjustment of Groomer" (Page 4-10)

## CR Brush Assy

Removal of CR Brush Assy (type with only CR brush installed)

Note:

Depending on the specifications, this function may not be available.

### Caution

Both the reel cutter (cutting cylinder) and the bed knife (bottom blade) are edged tools. Handle them carefully, since they could cut your hands and feet.

1. Remove the mower unit.
2. Remove the nuts, spring washers, washers and bolts from the roller bracket.

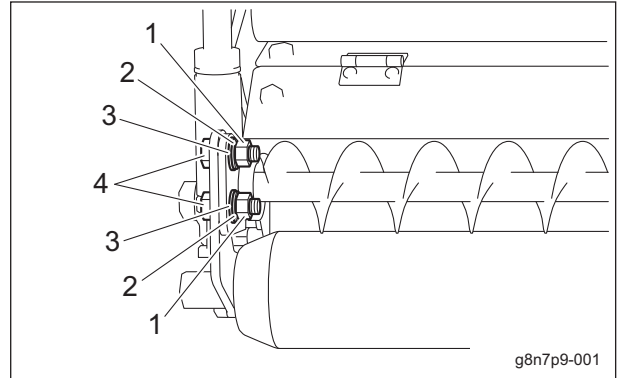

Removal of CR Brush Assy (type with only CR brush installed)\_001

1	Nut
2	Spring washer
3	Washer
4	Bolt

3. Remove the stop bolts and seal washers from the reel housing.
4. Remove the bolt, spring washer and washer holding the brush frame.

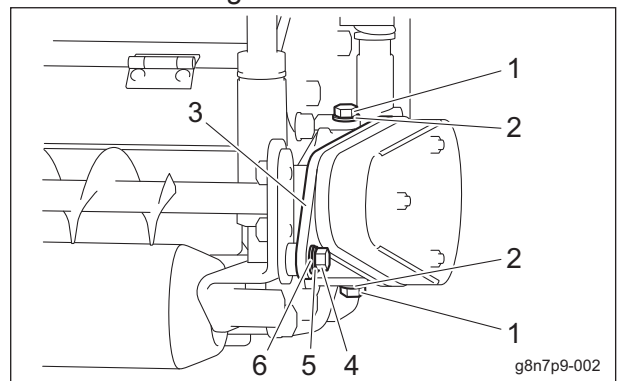

Removal of CR Brush Assy (type with only CR brush installed)\_002

1	Stop bolt
2	Seal washer
3	Brush frame
4	Bolt
5	Spring washer
6	Washer

# Operating Machine and Mower Units

5. Remove the CR brush assy in the direction of the arrow.

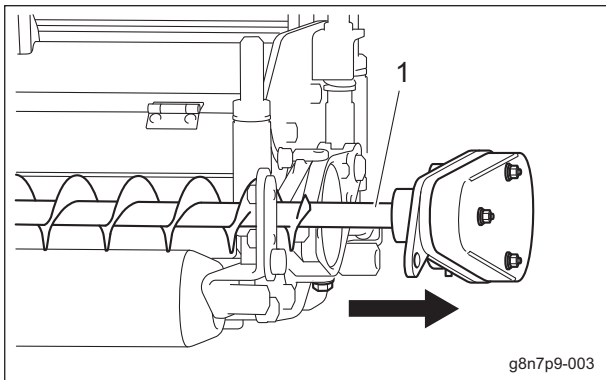

Removal of CR Brush Assy (type with only CR brush installed)\_003

1	CR brush assy
---	---------------

Removal of CR Brush Assy (type with groomer + CR brush installed together)

Note:

Depending on the specifications, this function may not be available.

**Caution**

The reel cutter (cutting cylinder), bed knife (bottom blade), and groomer blades are all edged tools. Handle them carefully, since they could cut your hands and feet.

1. Remove the mower unit.
2. Remove the nuts, spring washers, and washers, and then remove the case cover.

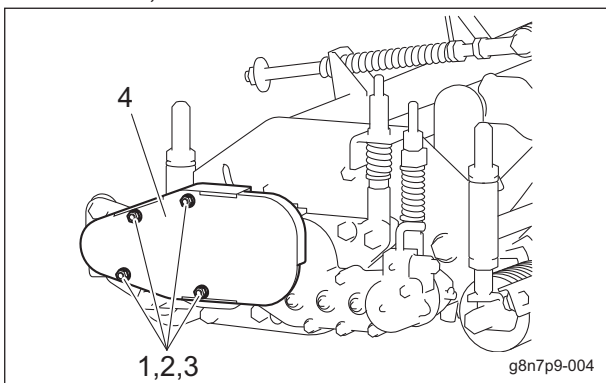

Removal of CR Brush Assy (type with groomer + CR brush installed together)\_001

1	Nut
2	Spring washer
3	Washer
4	Case cover

3. Lower the tension lever, and then remove the belt.

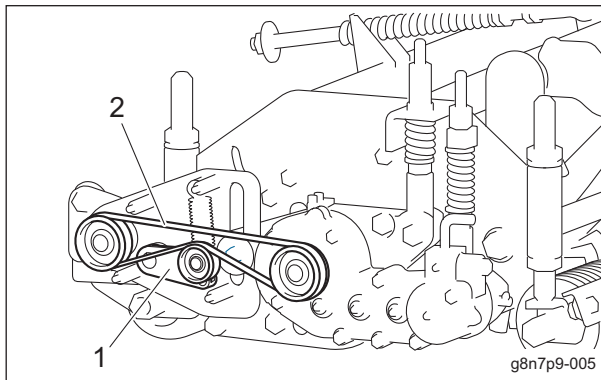

Removal of CR Brush Assy (type with groomer + CR brush installed together)\_002

1	Tension lever
2	Belt

4. Remove the U nuts, and then remove the bolt and washer.

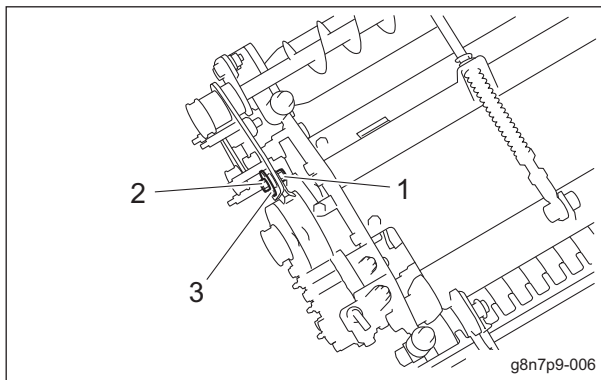

Removal of CR Brush Assy (type with groomer + CR brush installed together)\_003

1	U nut
2	Bolt
3	Washer

5. Remove the nuts, spring washers, washers and bolts securing the brush frame.

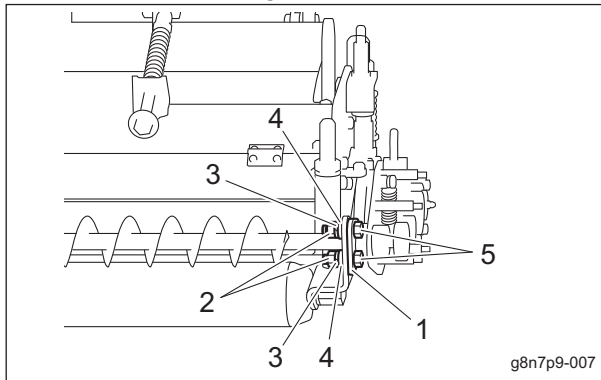

Removal of CR Brush Assy (type with groomer + CR brush installed together)\_004

# Operating Machine and Mower Units

1	Brush frame
2	Nut
3	Spring washer
4	Washer
5	Bolt

6. Remove the bolts, spring washers and washers securing the brush housing.

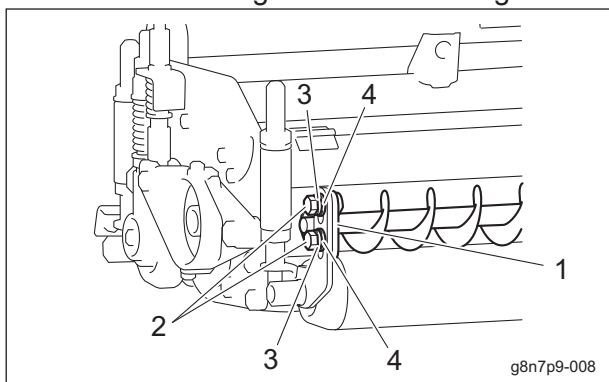

Removal of CR Brush Assy (type with groomer + CR brush installed together)\_005

1	Brush housing
2	Bolt
3	Spring washer
4	Washer

7. Remove the CR brush assy.

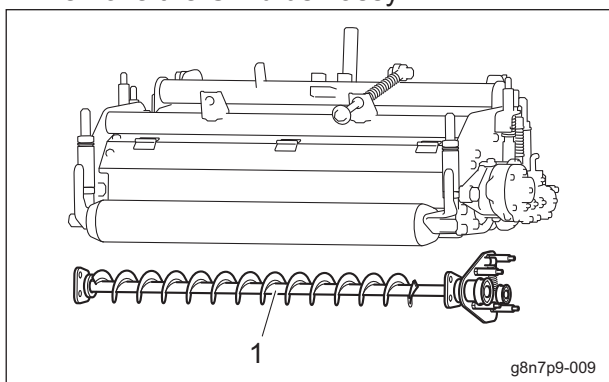

Removal of CR Brush Assy (type with groomer + CR brush installed together)\_006

1	CR brush assy
---	---------------

## Installation of CR Brush Assy

Note:

Depending on the specifications, this function may not be available.

### **! Danger**

Both the reel cutter (cutting cylinder) and the bed knife (bottom blade) are edged tools. Handle them carefully, since they could cut your hands and feet.

1. For installation, reverse the removing procedure.
2. Adjust the CR brush.  
"Adjustment of CR brush" (Page 4-11)

# Operating Machine and Mower Units

## Inspection and repair of each section

### Reel Cover

Due to frequent use, corrosion, or damage during use or transportation, the reel cover may be caught in the reel cutter. Inspect it, and if necessary, replace the parts.

- Check if the safety decals or instruction decals are not peeled off.
- Check if there is no crack, change in shape, etc. on the reel cover.

Refer to "Installation of Reel Cover" (Page 4-15) and "Removal of Reel Cover" (Page 4-15) for information on attaching and removing the reel cover.

### Reel cutter

#### Important

Be sure to replace the oil seals and bearings with new ones.

The reel cutter (cutting cylinder) may become dull due to frequent use, objects crushed during mowing, or damage caused during transportation.

Inspect it, and if necessary, grind or replace the reel cutter.

- Make sure that the welding between the reel cutter (cutting cylinder) and the disc has not come off.
- Make sure that the reel cutter is not cracked.
- Check to see whether or not the "relief" surface remains at the point of reel cutter (cutting cylinder).
- Check to see whether or not grinding burn and color change have occurred on the reel cutter.
- Check to see how much the reel cutter is worn.

Refer to "Removal of Reel Cutter" (Page 4-19) and "Attaching Reel Cutter (Cutting Cylinder)" (Page 4-21) for information on attaching and removing the reel cutter.

### Back Lapping of Reel Cutter (Cutting Cylinder)

Back lapping is work similar to sharpening a cooking knife. If the edges of the reel cutter (cutting cylinder) and the bed knife (bottom blade) become blunt and make cutting difficult, both the reel cutter (cutting cylinder) and the bed knife (bottom blade) should be simultaneously sharpened by reversing the reel cutter (cutting cylinder) with an abrasive paste applied.

However, back lapping is a temporary measure and would not restore the sharpness completely.

If the edges of the reel cutter (cutting cylinder) and the bed knife (bottom blade) become blunt and make cutting difficult, follow the steps below to perform back lapping.

#### ⚠ Caution

Both the reel cutter (cutting cylinder) and the bed knife (bottom blade) are edged tools. Handle them carefully, since they could cut your hands and feet.

#### ⚠ Caution

Be careful not to inhale exhaust gas during back lapping.

#### ⚠ Caution

During back lapping, the reel cutter (cutting cylinder) rotates. Keep hands and feet away from moving parts.

#### ⚠ Caution

Do not perform back lapping with any other persons.

1. Have the following items ready: Strips of newspaper, Abrasive [Back lapping powder mixed with oil; or gel compound (Baroness genuine abrasive)], Brush.

# Operating Machine and Mower Units

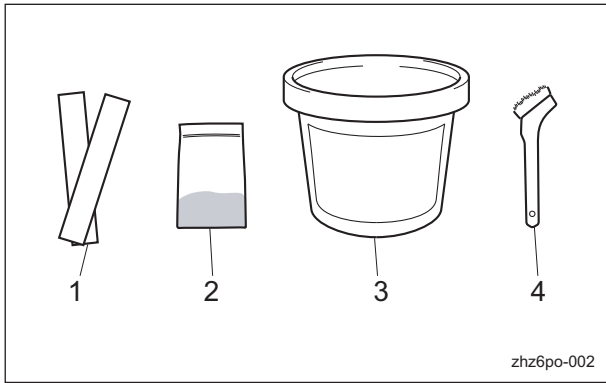

Back Lapping of Reel Cutter (Cutting Cylinder)\_001

1	Newspaper
2	Back lapping powder
3	Gel compound
4	Brush

**Note:**

The mixing ratio for the abrasive, in volume, is one part back lapping powder (#150 - #200) to three or four parts oil.

**Caution**

When handling the reel cutter (cutting cylinder) or bed knife (bottom blade), wear gloves to protect your hands. However, pay attention not to let the reel cutter (cutting cylinder) catch your gloves, etc. Otherwise, you may injure your hand or fingers.

**Important**

Check the sharpness of the blade by checking the blade engagement after cutting grass.

2. Stop the engine.
3. Set the reel rotation/stop switching lever to the "Stop" position.

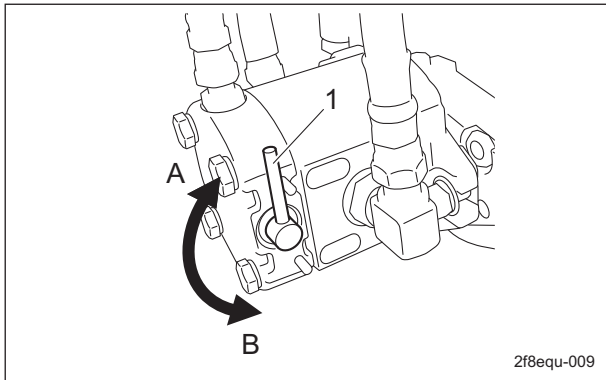

Back Lapping of Reel Cutter (Cutting Cylinder)\_002

1	Reel rotation/stop switching lever
A	Rotate
B	Stop

4. Insert two or three strips of newspaper into the space between the reel cutter (cutting cylinder) and the bed knife (bottom blade) at an angle of 90 degrees. Then, rotate the reel cutter (cutting cylinder) counter-clockwise (when you face the mower unit from the left) by hand to check the sharpness of the blades.
5. Check the sharpness of the entire range (three or four points from the left edge to the right one) of the reel cutter (cutting cylinder).
6. With a piece of chalk, etc., mark locations on the blade that are sharp.
7. Shift only the reel rotation/stop switching levers of the hydraulic motors in the mower units to be used for back lapping to the "Rotate" position. Shift the levers to the "Stop" position for the mower units for which you will not perform back lapping.
8. Sit on the seat, apply the parking brake, and then start the engine.
 

**Note:**  
If the reel rotation switch is set to the "Rotate" position, the engine will not start.
9. Lower all mower units to the ground.
10. Set the reel reverse switch to the "Reverse" position.
11. Run the engine at a low rpm.
12. Set the reel rotation switch to the "Rotate" position to rotate the reel cutter (cutting cylinder) for back lapping.
13. With the reel rotation/stop switching lever, adjust the rotation speed of the reel cutter (cutting cylinder).
14. Apply the abrasive evenly with the brush on the top side of reel cutter (cutting cylinder) where the newspaper was cut well or of chalk-marked locations. (Never apply to blunt areas.)
15. Idle the machine for a while, and when contact noise is no longer heard, set the reel rotation switch to the "Stop" position to stop the reel cutter (cutting cylinder).
16. Stop the engine.

# Operating Machine and Mower Units

17. Wash off or wipe off with a cloth, etc., the abrasive from the reel cutter (cutting cylinder), and then check the sharpness.
18. Repeat steps 3 to 17 until the entire range (three or four points from the left edge to the right one) of the reel cutter (cutting cylinder) will be uniformly sharpened.
19. Finally, apply abrasive to the entire blade width of the reel cutter (cutting cylinder) and perform final back lapping.
20. Set the reel rotation switch to the "Stop" position to stop the rotation of the reel cutter (cutting cylinder), stop the engine, and then carefully and thoroughly wash off any remaining abrasive.
21. Set the reel reverse switch to the "Normal rotation" position.
22. Shift the reel rotation/stop switching lever to the "Stop" position.
23. While checking the blade for sharpness, adjust blade engagement.

For sharpening the reel cutter (cutting cylinder), contact your dealer or Baroness. If the outer diameter of the reel cutter (cutting cylinder) after sharpening is more than the usage limit, the reel cutter (cutting cylinder) can be sharpened.

New		Usage limit	
Dimension A (Outer diameter of reel cutter (cutting cylinder))	Dimension B (Distance from blade edge to outer edge of reel cutter (cutting cylinder) shaft)	Dimension A (Outer diameter of reel cutter (cutting cylinder))	Dimension B (Distance from blade edge to outer edge of reel cutter (cutting cylinder) shaft)
163 mm (6.42 in)	68.8 mm (2.71 in)	143 mm (5.63 in)	58.8 mm (2.31 in)

**Note:**  
The outer diameter of the reel cutter (cutting cylinder) shaft is 25.4 mm (1.00 in).

## Sharpening of Reel Cutter (Cutting Cylinder)

**⚠ Caution**

Both the reel cutter (cutting cylinder) and the bed knife (bottom blade) are edged tools. Handle them carefully, since they could cut your hands and feet.

**⚠ Caution**

Wear gloves when touching edged tools to avoid cutting your hands.

The sharpening of the reel cutter (cutting cylinder) consists in maintaining its roundness and creating a relief (second edge face). This work should be performed if the sharpness cannot be restored, even after back lapping, or if the relief (second edge face) has worn away.

Sharpen the reel cutter (cutting cylinder) when the sharpness cannot be restored, even after back lapping, or when the relief (second edge face) has worn away, there is full contact or back lapping takes too much time.

In addition, if the reel cutter (cutting cylinder) becomes worn and its shape conical, perform cylindrical grinding to return it to a cylindrical shape.

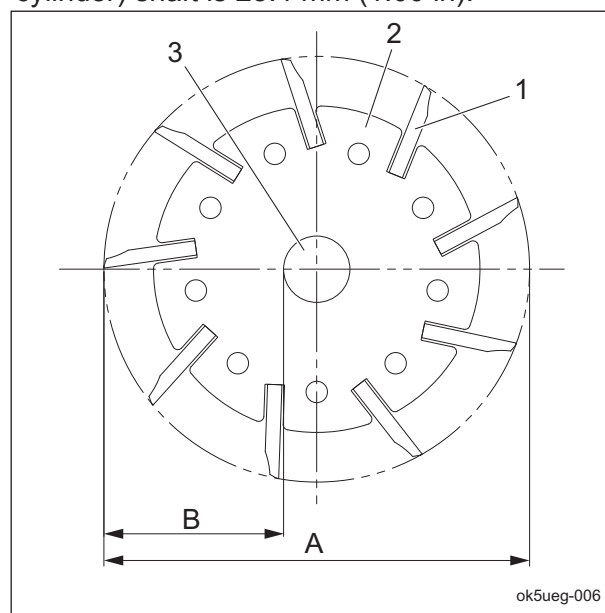

Sharpening of Reel Cutter (Cutting Cylinder)\_001

1	Reel cutter (cutting cylinder) blade
2	Reel cutter (cutting cylinder) disc
3	Reel cutter (cutting cylinder) shaft
A	Outer diameter of reel cutter (cutting cylinder)
B	Distance from blade edge to outer edge of reel cutter (cutting cylinder) shaft

# Operating Machine and Mower Units

Sharpening is necessary when the reel cutter (cutting cylinder) reaches a condition described below.

1. When the sharpening width (length of contacting surface of bed knife (bottom blade)) for the outer diameter of the reel cutter (cutting cylinder) is greater than the usage limit.

Outer diameter of reel cutter (cutting cylinder) (new part)	Usage limit of sharpening width for outer diameter of reel cutter (cutting cylinder)
163 mm (6.42 in)	3.0 mm (0.12 in) (factory-recommended)

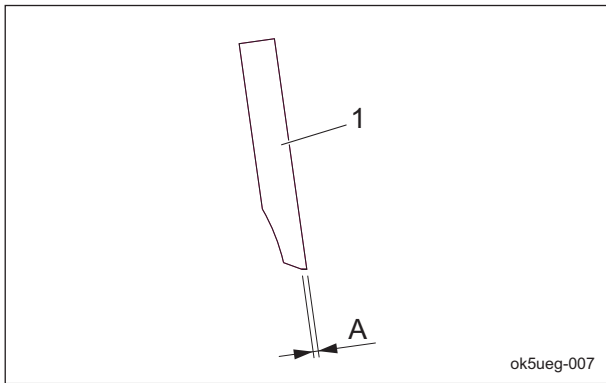

Sharpening of Reel Cutter (Cutting Cylinder)\_002

1	Reel cutter (cutting cylinder) blade
A	Sharpening width for outer diameter of reel cutter (cutting cylinder)

2. When the edges become blunt or the blade edge cannot be formed with back lapping
3. When the reel cutter (cutting cylinder) becomes worn and its shape conical, or when blade engagement adjustment cannot be performed

■ Bearing/Holder for Grinding Machine

These are used for the types of grinding machines which performs centering of the reel cutter with using bearings.

**Important**

Be sure to confirm how to receive the bearings because that method varies among grinding machines.

1. Holder Assy  $\phi 52$

The bearing holder assy is used on the both sides of the shaft in the case of the bearing holder of the grinding machine of inner  $\Phi 52$ .

2. Holder Assy  $\phi 60$

The bearing holder assy is used on the both sides of the shaft in the case of the bearing holder of the grinding machine of inner  $\Phi 60$ .

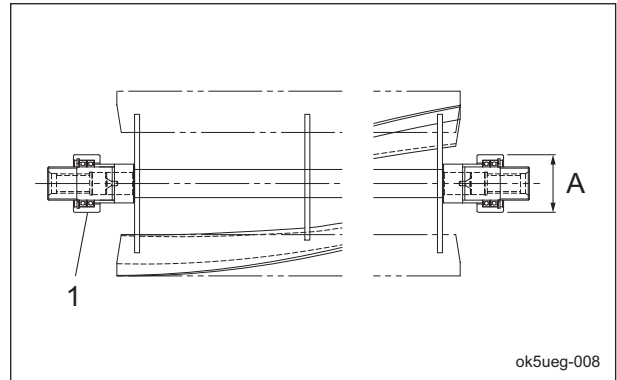

Bearing/Holder for Grinding Machine\_001

1	Holder assy
A	Bearing holder assy outer diameter

**Important**

Use a double-sealed bearing, because dust, dirt, etc. adversely affect the movement of bearings.

3. The bearing is used on the both sides of the shaft if the bearing holder of the grinding machine is V type.

Note:

Bearing #62062RD (Outer  $\Phi 62$ )

Bearing #60062RD (Outer  $\Phi 55$ )

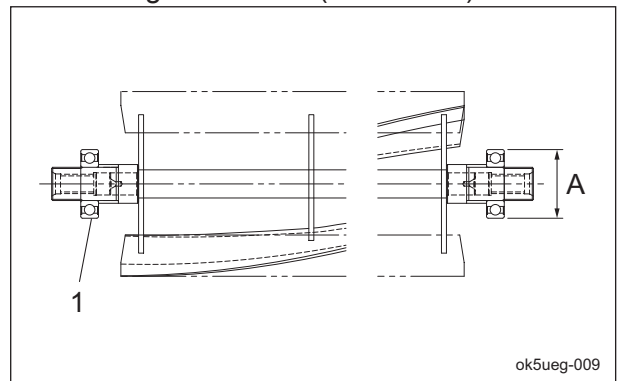

Bearing/Holder for Grinding Machine\_002

1	Bearing
A	Bearing outer diameter

# Operating Machine and Mower Units

## Replacement of Reel Cutter (Cutting Cylinder)

**⚠ Caution**

Both the reel cutter (cutting cylinder) and the bed knife (bottom blade) are edged tools. Handle them carefully, since they could cut your hands and feet.

**⚠ Caution**

Wear gloves when touching edged tools to avoid cutting your hands.

The criteria for replacing the reel cutter (cutting cylinder) are described below. However, these criteria are only a reference and do not guarantee performance like that of a new reel cutter (cutting cylinder).

1. When the outer diameter of the reel cutter (cutting cylinder) is less than the usage limit

New		Usage limit	
Dimension A (Outer diameter of reel cutter (cutting cylinder))	Dimension B (Distance from blade edge to outer edge of reel cutter (cutting cylinder) shaft)	Dimension A (Outer diameter of reel cutter (cutting cylinder))	Dimension B (Distance from blade edge to outer edge of reel cutter (cutting cylinder) shaft)
163 mm (6.42 in)	68.8 mm (2.71 in)	143 mm (5.63 in)	58.8 mm (2.31 in)

**Note:**

The outer diameter of the reel cutter (cutting cylinder) shaft is 25.4 mm (1.00 in).

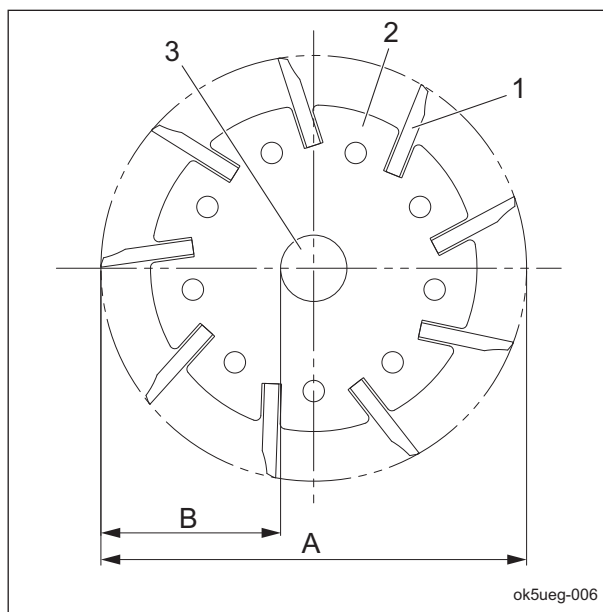

Replacement of Reel Cutter (Cutting Cylinder)\_001

1	Reel cutter (cutting cylinder) blade
2	Reel cutter (cutting cylinder) disc
3	Reel cutter (cutting cylinder) shaft
A	Outer diameter of reel cutter (cutting cylinder)
B	Distance from blade edge to outer edge of reel cutter (cutting cylinder) shaft

# Operating Machine and Mower Units

## Reel Housing

Wear of bearings due to frequent use and/or damage of bearings, etc. caused by invasion of water may prevent smooth rotation of the reel cutter.

Inspect and replace the parts such as the oil seal and bearings.

- Make sure that the reel housing does not have any crack.
- Make sure that the spindle bolt and housing bolt receptacles are not shaky.
- Make sure that the bearing receptacle is not shaky.

**⚠ Caution**

Both the reel cutter (cutting cylinder) and the bed knife (bottom blade) are edged tools. Handle them carefully, since they could cut your hands and feet.

**⚠ Caution**

"Tightening torques" (Page 3-5) See the list. Note that the Baroness product warranty may not apply to defects caused by incorrect or overtorque tightening, etc.

1. Remove the reel housing from the reel cutter.  
"Removal of Reel Cutter" (Page 4-19)

**Important**

The bearing and oil seal have a specific installation orientation. Confirm its direction.

**Important**

The stop ring has a specific installation orientation. Confirm its direction.

**Important**

The grease nipple of the reel housing has a specific installation direction. Confirm its direction.

2. Remove the grease nipple.

3. Remove the bearing, oil seal, and stop ring in order from the reel housing.

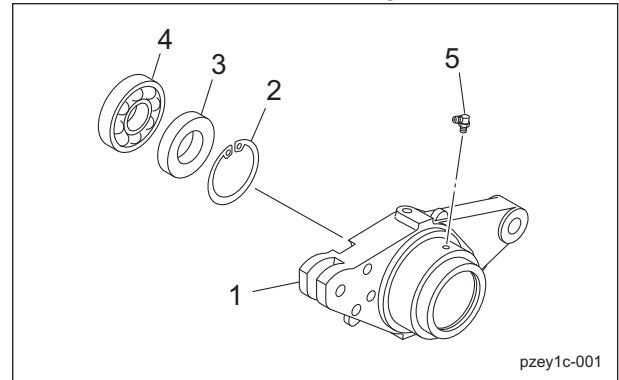

Reel Housing\_001

1	Reel housing
2	Stop ring
3	Oil seal
4	Bearing
5	Grease nipple

**Important**

The stop ring has a specific installation orientation. Install it in the correct orientation.

4. Install the stop ring to the reel housing.

**Important**

Be sure to replace the bearing and oil seal with new ones.

5. Apply a profuse amount of grease on new bearings and oil seals. Apply a profuse amount of grease to the lip of the oil seal.

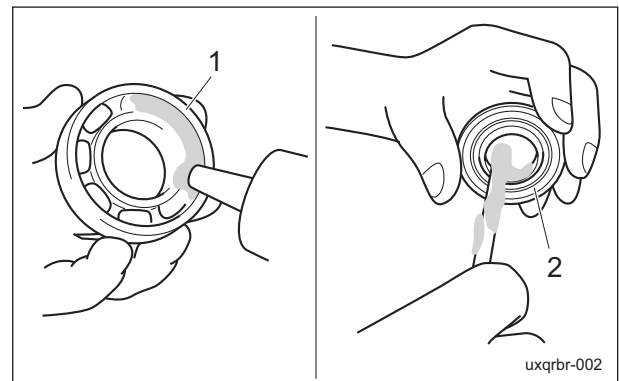

Reel Housing\_002

1	Bearing
2	Oil seal

# Operating Machine and Mower Units

**Important**

The bearing and oil seal have a specific installation orientation. Install it in the correct orientation.

- Tap the oil seal and bearing into the reel housing evenly.  
**Note:**  
 Use a bearing driver to drive in the bearings and oil seals.

**Important**

The grease nipple of the reel housing has a specific installation direction. Install it in the correct orientation.

- Install the grease nipple.
- Install the reel housing.

## Reel Housing (with housing lid)

Wear of bearings due to frequent use and/or damage of bearings, etc. caused by invasion of water may prevent smooth rotation of the reel cutter.

Inspect and replace the parts such as the oil seal and bearings.

- Make sure that the reel housing does not have any crack.
- Make sure that the spindle bolt and housing bolt receptacles are not shaky.
- Make sure that the bearing receptacle is not shaky.

**Caution**

Both the reel cutter (cutting cylinder) and the bed knife (bottom blade) are edged tools. Handle them carefully, since they could cut your hands and feet.

**Caution**

"Tightening torques" (Page 3-5) See the list. Note that the Baroness product warranty may not apply to defects caused by incorrect or overtightening, etc.

**Important**

The grease nipple of the reel housing has a specific installation direction. Confirm its direction.

- Remove the reel housing from the reel cutter.  
 "Removal of Reel Cutter" (Page 4-19)
- Remove the grease nipple.
- Remove the bolt and spring washer, and then remove the housing cover.

**Important**

The stop ring has a specific installation orientation. Confirm its direction.

**Important**

The bearing and oil seal have a specific installation orientation. Confirm its direction.

- Remove the packing and stop ring.
- Remove the oil seal and bearing.

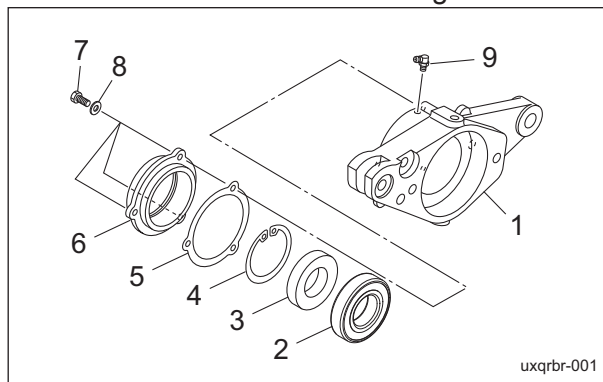

Reel Housing (with housing lid)\_001

1	Reel housing
2	Bearing
3	Oil seal
4	Stop ring
5	Packing
6	Housing cover
7	Bolt
8	Spring washer
9	Grease nipple

**Important**

Be sure to replace the bearing, oil seal and packing with new ones.

- Apply a profuse amount of grease on new bearings and oil seals. Apply a profuse amount of grease to the lip of the oil seal.

# Operating Machine and Mower Units

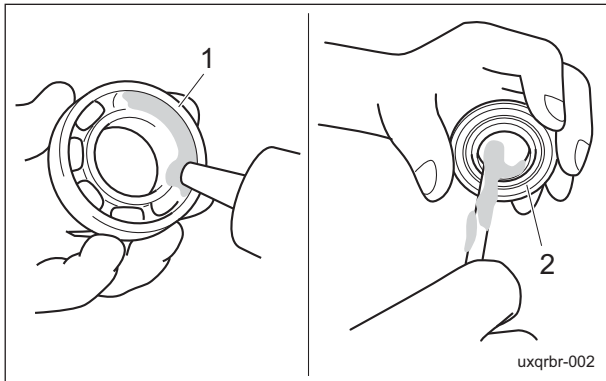

Reel Housing (with housing lid)\_002

1	Bearing
2	Oil seal

**Important**

The bearing and oil seal have a specific installation orientation. Install it in the correct orientation.

- Tap the bearing into the reel housing evenly.  
Note:  
Use a bearing driver to drive in the bearings and oil seals.

**Important**

The stop ring has a specific installation orientation. Install it in the correct orientation.

- Install the stop ring onto the housing lid.
- Tap the oil seal into the housing lid evenly.  
Note:  
Use a bearing driver to drive in the bearings and oil seals.
- Install the packing and housing lid onto the reel housing with the bolt and spring washer.

**Important**

The grease nipple of the reel housing has a specific installation direction. Install it in the correct orientation.

- Install the grease nipple.

## Bed knife

### Replacement of Bed Knife (Bottom Blade)

**Caution**

Both the reel cutter (cutting cylinder) and the bed knife (bottom blade) are edged tools. Handle them carefully, since they could cut your hands and feet.

**Caution**

Wear gloves when touching edged tools to avoid cutting your hands.

The criteria for replacing the bed knife (bottom blade) are described below.

- When the reel cutter (cutting cylinder) is ground
- When the reel cutter (cutting cylinder) is replaced
- When the bed knife (bottom blade) is worn  
High-speed-steel-tipped blade  
Replace the bed knife (bottom blade) before it no longer has a tip.

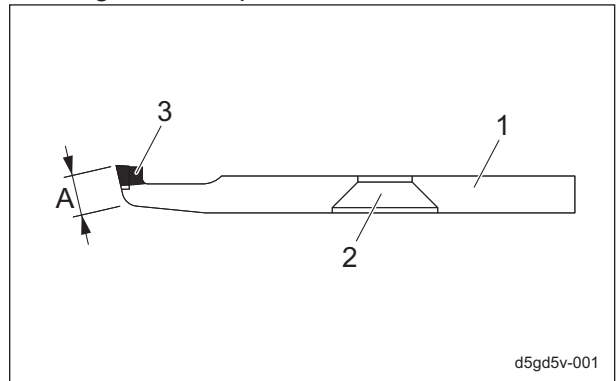

Replacement of Bed Knife (Bottom Blade)\_001

1	Bed knife (bottom blade)
2	Mounting hole
3	Tip
A	Front face

# Operating Machine and Mower Units

## Roller

### Front Roller

Wear of bearings due to frequent use and/or damage of bearing, etc. caused by invasion of water may prevent smooth rotation of the roller.

Inspect and replace the parts such as the oil seal and bearings.

- Make sure that there is no abrasion or adhesion of the roller.
- Make sure that there is no abrasion of the collars nor nuts on both ends.
- Make sure that there is no wear or rust of the bearing or play of the housing or bearing.

**⚠ Danger**

Both the reel cutter (cutting cylinder) and the bed knife (bottom blade) are edged tools. Handle them carefully, since they could cut your hands and feet.

**⚠ Caution**

"Tightening torques" (Page 3-5) See the list. Note that the Baroness product warranty may not apply to defects caused by incorrect or overtorque tightening, etc.

1. Remove the front roller assy.
2. Follow the steps below to disassemble the front roller.

[1] Use the special wrench to loose the roller housing and nuts of one side, and remove the roller housing.

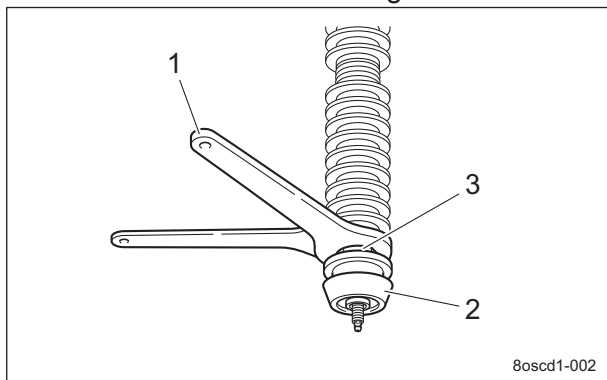

Front Roller\_001

1	Special wrench
2	Roller housing
3	Nut

[2] Pull out the roller shaft, and then remove the plate and nut.

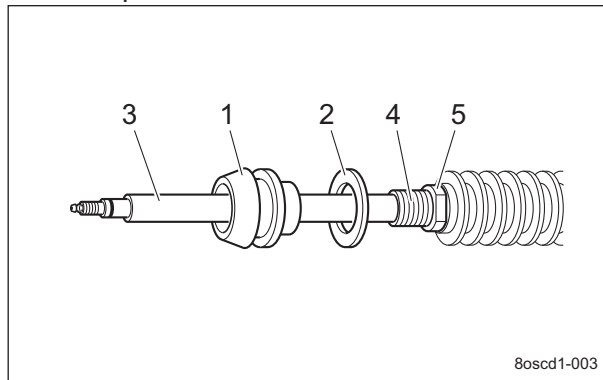

Front Roller\_002

1	Roller housing
2	Plate
3	Roller shaft
4	Roller pipe
5	Nut

[3] Remove the rollers, adjustment washers, and spring from the roller pipe.

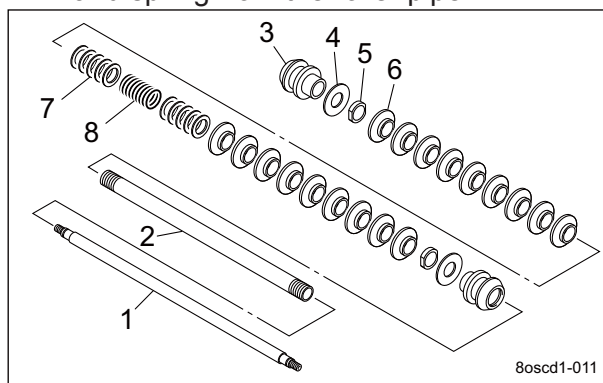

Front Roller\_003

1	Roller shaft
2	Roller pipe
3	Roller housing
4	Plate
5	Nut
6	Roller
7	Adjustment washer
8	Spring

# Operating Machine and Mower Units

[4] Use the special wrench to loose the roller housing and nut on the other side, and remove the roller housing, plate, and nut from the roller pipe.

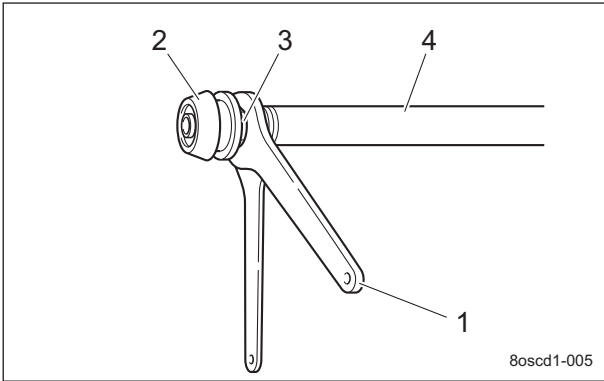

Front Roller\_004

1	Special wrench
2	Roller housing
3	Nut
4	Roller pipe

**Note:**

When disassembling the roller pipe, only the nut may be loosen and the roller housing and roller pipe may not be loosen.

In such a case, lock the nut and roller housing of the other side with the special wrench, and loose the roller housing.

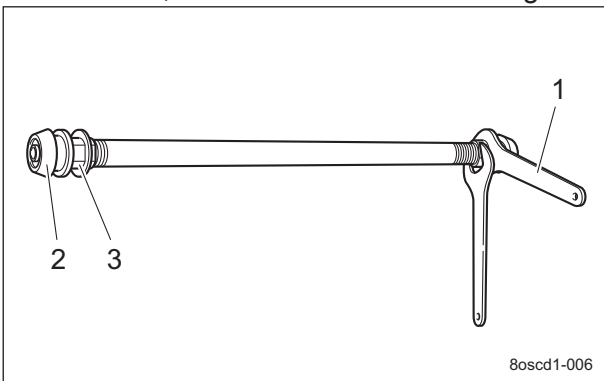

Front Roller\_005

1	Special wrench
2	Roller housing
3	Nut

[5] Remove stop ring A, collar, O-ring, oil seal A, bearing, oil seal B, and stop ring B from the roller housing.

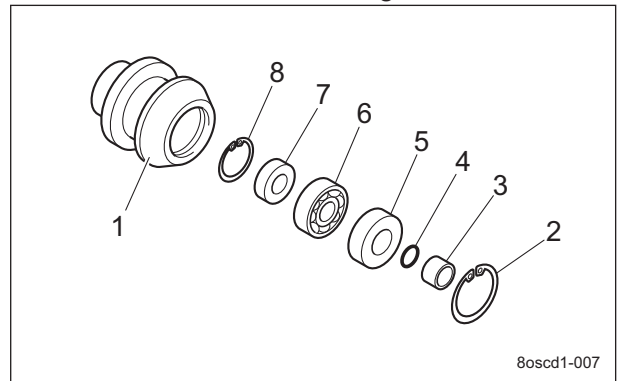

Front Roller\_006

1	Roller housing
2	Stop ring A
3	Collar
4	O-ring
5	Oil seal A
6	Bearing
7	Oil seal B
8	Stop ring B

**Important**

Be sure to replace the bearing, oil seal, and O-ring with new ones.

3. Apply a profuse amount of grease on new bearings and oil seals. For bearings, apply the grease until it overflows from the opposite side. Apply a profuse amount of grease to the lip of the oil seal.

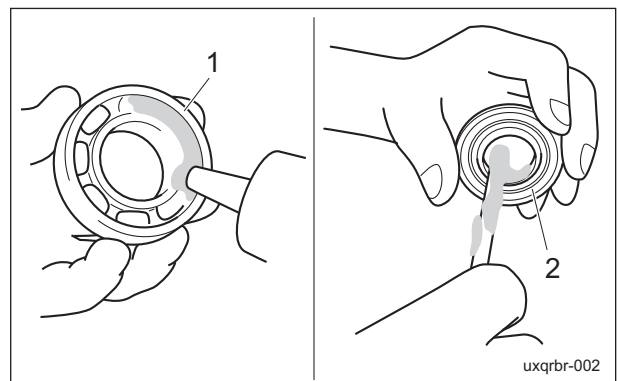

Front Roller\_007

1	Bearing
2	Oil seal

# Operating Machine and Mower Units

4. Follow the steps below to assemble the front roller.

**Important**

The stop ring has a specific installation orientation. Install it in the correct orientation.

[1] Install stop ring B, oil seal B, bearing, oil seal A, O-ring, collar, and stop ring A onto the roller housing.

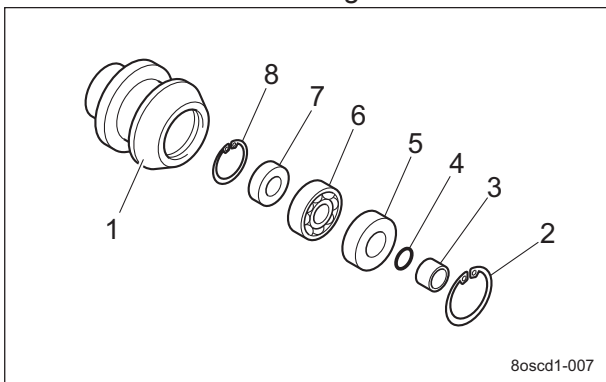

Front Roller\_008

1	Roller housing
2	Stop ring A
3	Collar
4	O-ring
5	Oil seal A
6	Bearing
7	Oil seal B
8	Stop ring B

**Important**

The roller housing to be installed first must be pushed all the way into the roller pipe.

[2] Install the nut, plate, and roller housing in order onto one side of the roller pipe, and lock them with a nut.

[3] Install the roller shaft, rollers, adjustment washers, and spring onto the roller pipe.

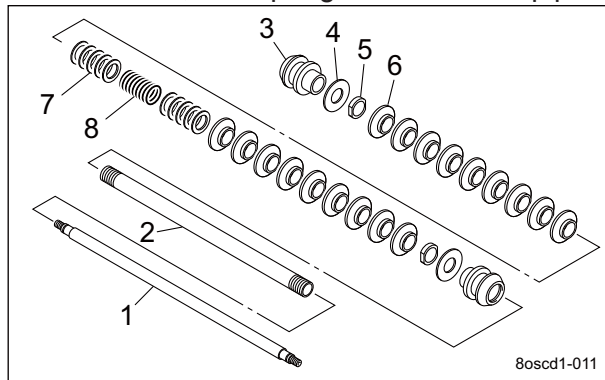

Front Roller\_009

1	Roller shaft
2	Roller pipe
3	Roller housing
4	Plate
5	Nut
6	Roller
7	Adjustment washer
8	Spring

[4] Install the nuts and tighten them to the maximum extent.

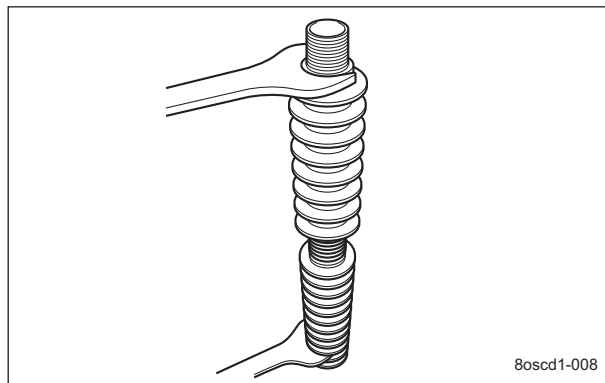

Front Roller\_010

[5] Install the plate to the roller pipe.

[6] Tighten the roller housing to the roller pipe.

Operating Machine and Mower Units

# Operating Machine and Mower Units

[7] Secure the roller housing with nut.

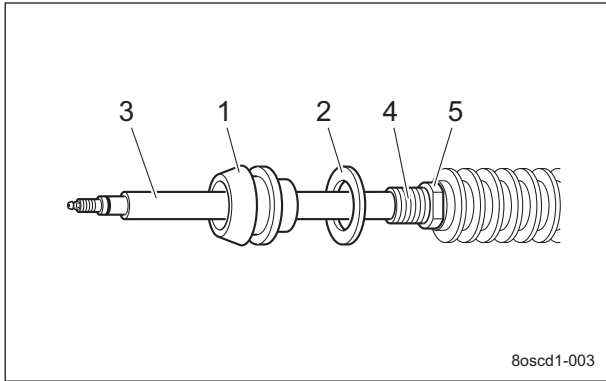

Front Roller\_011

1	Roller housing
2	Plate
3	Roller shaft
4	Roller pipe
5	Nut

5. Check the total length of the front roller assy.

26-inch specification	696.0 mm (27.40 in)
22-inch specification	593.5 mm (23.36 in)

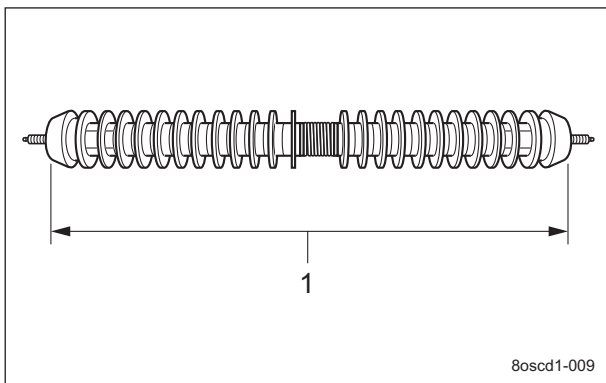

Front Roller\_012

1	Total length
---	--------------

Note:

If the total length is longer than the standard dimension, the tightening of the roller housing is insufficient.

6. Make sure that the roller rotates smoothly with no play when the roller shaft is fixed.

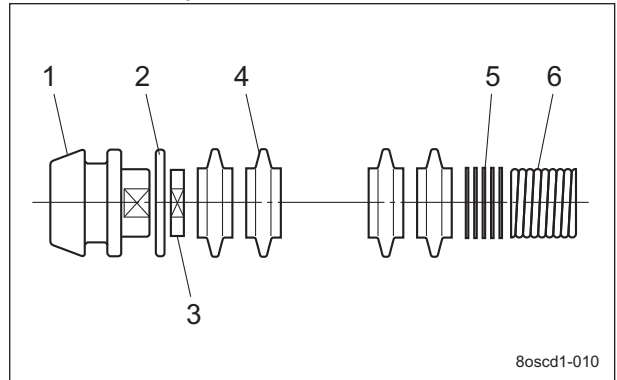

Front Roller\_013

1	Roller housing
2	Plate
3	Nut
4	Roller
5	Adjustment washer
6	Spring

Note:

If the roller does not rotate, the spring has play, or the roller has a backlash, adjust the clearance of the spring with the adjustment washers.

When the roller is pushed toward the spring, the clearance of the spring is 1.0 to 3.0 mm (0.039 to 0.118 in).

7. Apply grease.

"Greasing Points" (Page 3-9)

8. Install the front roller assy.

"Installation of Front Roller Assy" (Page 4-25)

# Operating Machine and Mower Units

## Rear Roller

Wear of bearings due to frequent use and/or damage of bearing, etc. caused by invasion of water may prevent smooth rotation of the roller.

Inspect and replace the parts such as the oil seal and bearings.

- Make sure that there is no abrasion or adhesion of the rear roller.
- Make sure that there is no abrasion of the collars nor nuts on both ends.
- Make sure that there is no wear or rust of the bearing or play of the housing or bearing.

**Caution**

Both the reel cutter (cutting cylinder) and the bed knife (bottom blade) are edged tools. Handle them carefully, since they could cut your hands and feet.

**Caution**

"Tightening torques" (Page 3-5) See the list. Note that the Baroness product warranty may not apply to defects caused by incorrect or overtorque tightening, etc.

1. Remove the rear roller assy.  
"Removal of the Rear Roller Assy" (Page 4-26)
2. Remove the left and right stop rings from the rear roller assy.

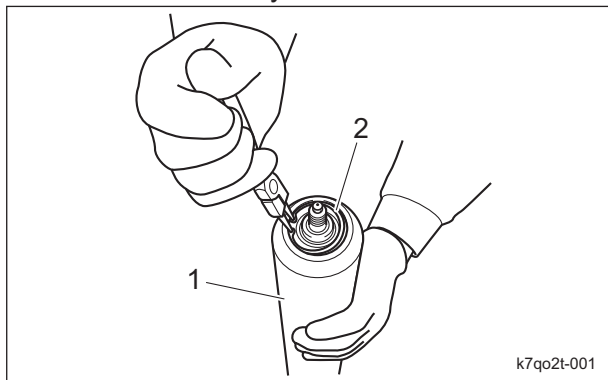

Rear Roller\_001

1	Rear roller assy
2	Stop ring

3. Knock one end of the roller shaft with a plastic hammer to push out the shaft.

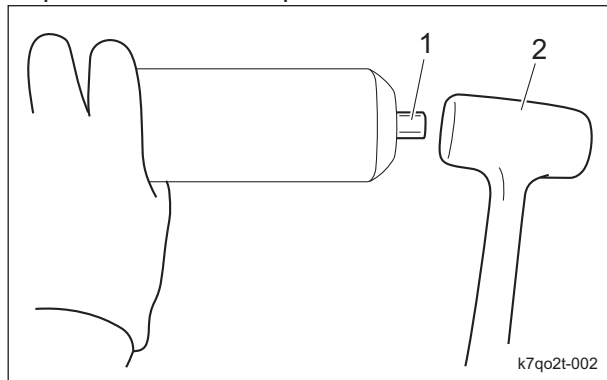

Rear Roller\_002

1	Roller shaft
2	Plastic hammer

**Note:**

The roller shaft protrudes from the side which is not hit by the plastic hammer.

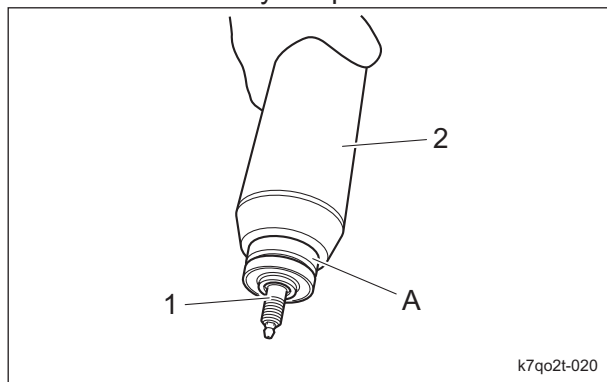

Rear Roller\_003

1	Roller shaft
2	Roller
A	Roller shaft protrusion

4. Remove the collar, O-ring, oil seal, washer, and bearing from the roller shaft.

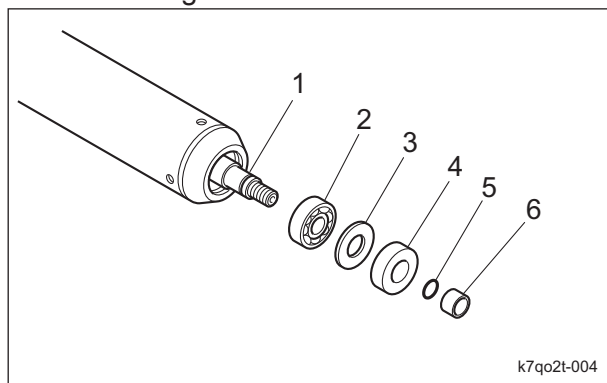

Rear Roller\_004

# Operating Machine and Mower Units

1	Roller shaft
2	Bearing
3	Washer
4	Oil seal
5	O-ring
6	Collar

- Remove the one in the opposite side as well in the same procedure.
- Remove the oil seal from the roller.

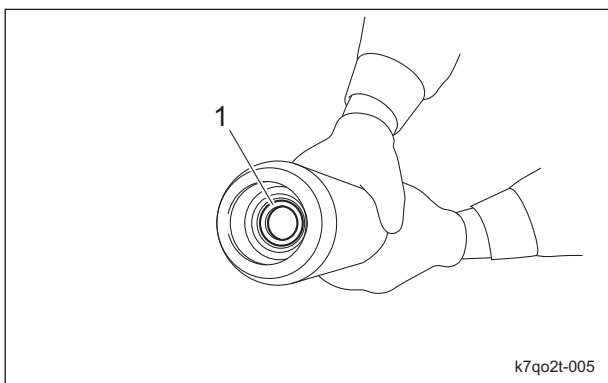

k7qo2t-005

Rear Roller\_005

1	Oil seal
---	----------

**Important**

Be sure to replace the bearings, oil seals and O-rings with new ones.

- Apply a profuse amount of grease on new bearings, O-rings, and oil seals.  
For bearings, apply the grease until it overflows from the opposite side.  
Apply a profuse amount of grease to the lip of the oil seal.

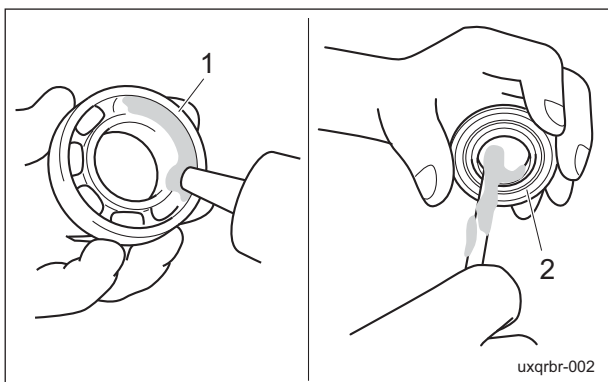

uxqrbr-002

Rear Roller\_006

1	Bearing
2	Oil seal

**Important**

The stop ring has a specific installation orientation.  
Install it in the correct orientation.

- Install the rear roller assy following the reversed procedure of the procedure 2 to 7.
- Make sure that the roller rotates smoothly with no play when the roller shaft is fixed.
- Apply grease.  
"Greasing Points" (Page 3-9)
- Install the rear roller assy to the mower unit.  
"Installation of Rear Roller Assy" (Page 4-27)

# Operating Machine and Mower Units

## Groomer Assy

### Groomer Case

**Note:**

Depending on the specifications, this function may not be available.

Wear of bearings due to frequent use and/or damage of bearing, etc. caused by invasion of water may prevent smooth rotation of the groomer.

Inspect and replace the parts such as the oil seal and bearings.

- Make sure that there is no change in shape, breakage, etc. on the groomer blades.
- Make sure that the groomer shaft is not bent nor worn.
- Make sure that there is no crack on the groomer case and groomer cover.
- Make sure that the intermediate shaft of the groomer cover has no play.
- Make sure that the bearings and shaft receptacle of the groomer case have no play.
- Make sure that the shifter receptacle of the groomer case has no play.

**Caution**

The reel cutter (cutting cylinder), bed knife (bottom blade), and groomer blades are all edged tools. Handle them carefully, since they could cut your hands and feet.

**Caution**

"Tightening torques" (Page 3-5) See the list. Note that the Baroness product warranty may not apply to defects caused by incorrect or overtightening, etc.

1. Remove the groomer case assy.
  - "Removal of Groomer Case Assy (type with only groomer installed)" (Page 4-27)
  - "Removal of Groomer Case Assy (type with groomer + CR brush installed together)" (Page 4-29)

2. Follow the steps below to remove the groomer cover from the groomer case assy.
  - [1] If there is a CR brush, remove the 2 drive pulley hollow screws, and remove the driving pulley and key.

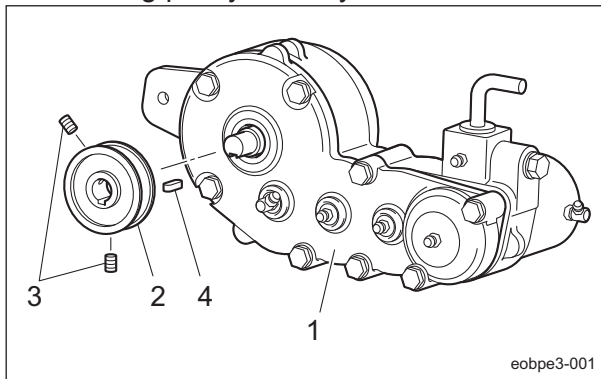

Groomer Case\_001

1	Groomer case assy
2	Driving pulley
3	Hollow screw
4	Key

- [2] Remove the bolt, seal washer, spring, and steel ball, and remove the clutch lever.

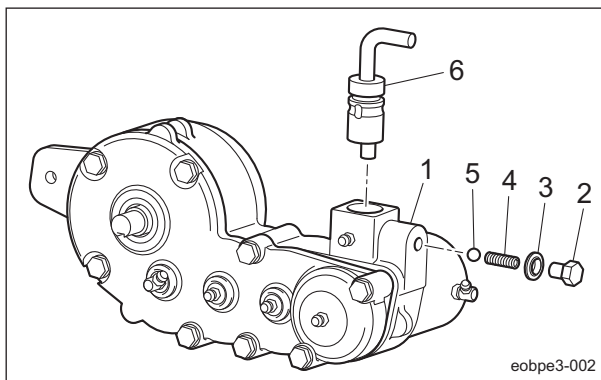

Groomer Case\_002

1	Groomer case assy
2	Bolt
3	Seal washer
4	Spring
5	Steel ball
6	Clutch lever

- [3] Remove bolt A and bolt B, and then remove the disc spring washer.

Operating Machine and Mower Units

# Operating Machine and Mower Units

[4] Tap two parts of the arrow alternatively with a wood hammer, etc. to remove the groomer cover.

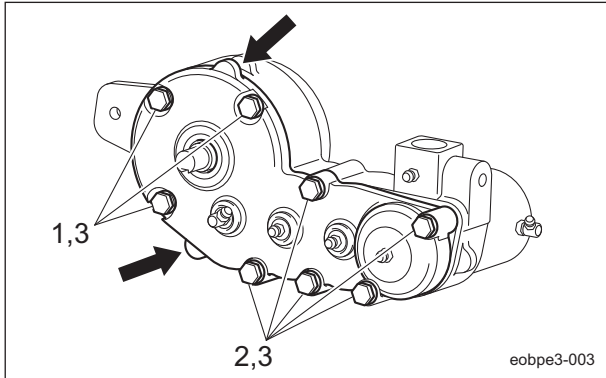

Groomer Case\_003

1	Bolt A
2	Bolt B
3	Disc spring washer

3. Follow the steps below to disassemble the groomer cover.

- [1] Remove all grease nipples.
- [2] Remove the copper washers, gear, and needle bearing.

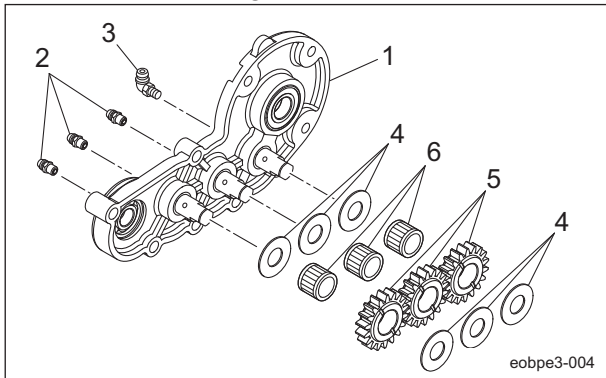

Groomer Case\_004

1	Groomer cover
2	Grease nipple (type A)
3	Grease nipple (type C)
4	Copper washer
5	Gear
6	Needle bearing

[3] Remove the stop ring and bearing A.

[4] Remove the bearing B.

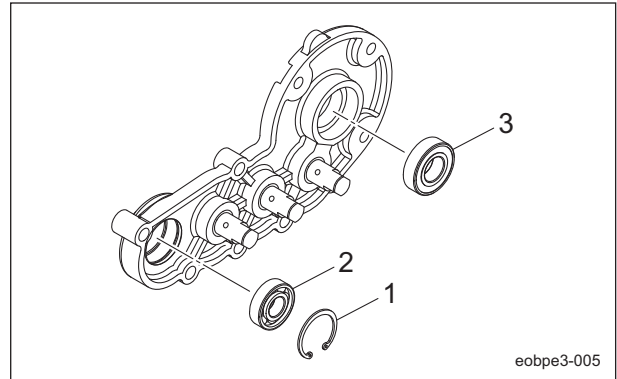

Groomer Case\_005

1	Stop ring
2	Bearing A
3	Bearing B

[5] Remove the intermediate shaft and O-ring that are screwed in to the case.

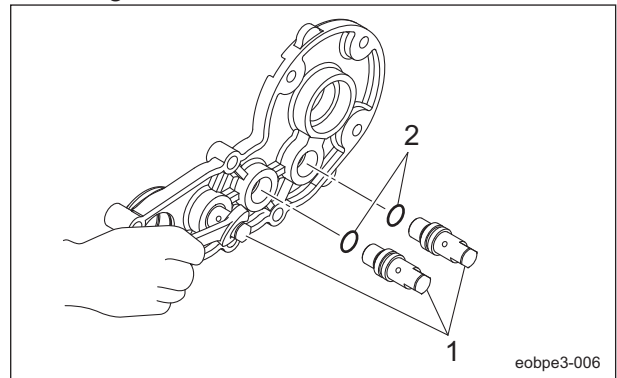

Groomer Case\_006

1	Intermediate shaft
2	O-ring

4. Follow the steps below to disassemble the groomer case.

- [1] Remove the stop ring from the groomer case, and remove the drive gear, key and drive shaft.
- [2] Remove the clutch gear and spline shaft.

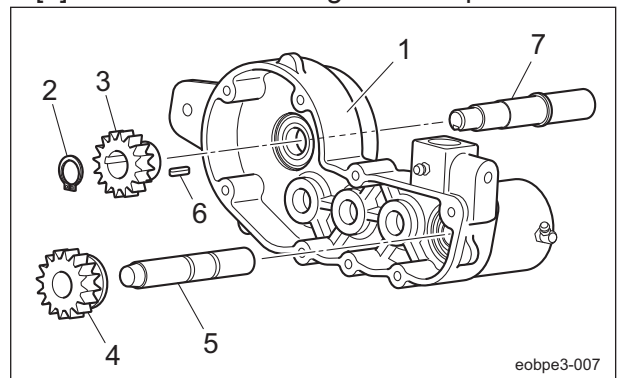

Groomer Case\_007

# Operating Machine and Mower Units

1	Groomer case
2	Stop ring
3	Drive gear
4	Clutch gear
5	Spline shaft
6	Key
7	Drive shaft

[3] Remove the stop ring, bearing A, and bearing B.

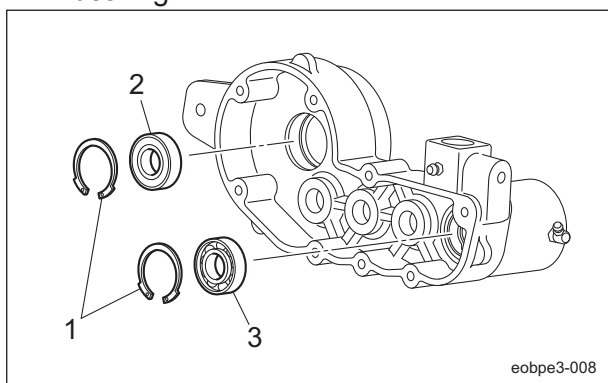

Groomer Case\_008

1	Stop ring
2	Bearing A
3	Bearing B

[4] Remove the stop rings, oil seal and bearings.

[5] Remove all grease nipples.

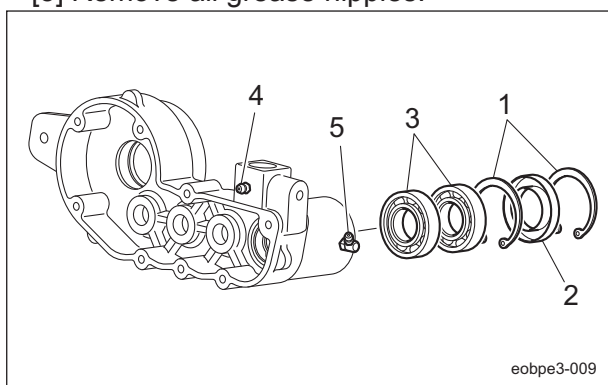

Groomer Case\_009

1	Stop ring
2	Oil seal
3	Bearing
4	Grease nipple (type A)
5	Grease nipple (type C)

5. Follow the steps below to assemble the groomer case assy.

**Important**

Be sure to replace the bearing and oil seal with new ones.

[1] Apply a profuse amount of grease on new bearings and oil seals. For bearings, apply the grease until it overflows from the opposite side. Also apply a profuse amount of grease to the lip of the oil seal.

**Note:**

Use a bearing driver to drive in the bearings and oil seals.

[2] Install the groomer case assy following the reversed procedure of the procedure 2 to 4.

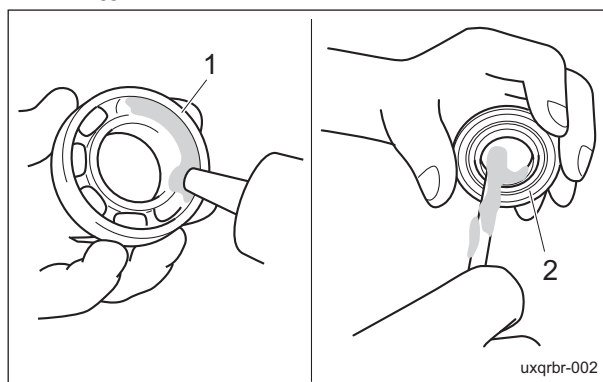

Groomer Case\_010

1	Bearing
2	Oil seal

**Note:**

Assemble the long bosses (indicated with arrows) of the 18-tooth gear to the groomer cover.

# Operating Machine and Mower Units

[3] Apply additional grease to the groomer case.  
 Note:  
 The grease quantity is approximately 60 g (0.13 lb).

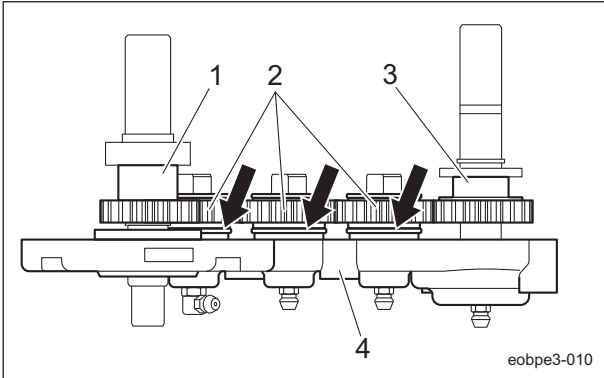

Groomer Case\_011

1	Drive gear
2	18-tooth gear
3	Clutch gear
4	Groomer cover

## Groomer Shaft

Note:  
 Depending on the specifications, this function may not be available.  
 Wear of bearings due to frequent use and/or damage of bearing, etc. caused by invasion of water may prevent smooth rotation of the groomer.  
 Inspect and replace the parts such as the oil seal and bearings.

- Make sure that there is no change in shape, breakage, etc. on the groomer blades.
- Make sure that the groomer shaft is not bent nor worn.  
 Make sure that the groomer housing does not have any crack.
- Make sure that the bearings receptacle of the groomer housing has no play.
- Make sure that there is no wear of the collar.

### ⚠ Caution

The reel cutter (cutting cylinder), bed knife (bottom blade), and groomer blades are all edged tools. Handle them carefully, since they could cut your hands and feet.

### ⚠ Caution

"Tightening torques" (Page 3-5) See the list. Note that the Baroness product warranty may not apply to defects caused by incorrect or overtorque tightening, etc.

1. Remove the groomer shaft assy.  
 "Removal of Groomer Shaft Assy" (Page 4-30)
2. Remove the groomer housing from the groomer shaft assy.
3. Follow the steps below to disassemble the groomer housing.  
 [1] Remove the dust-proof cover, collars, stop rings and oil seals.  
 The dust-proof cover and collar may be remaining on the groomer shaft.

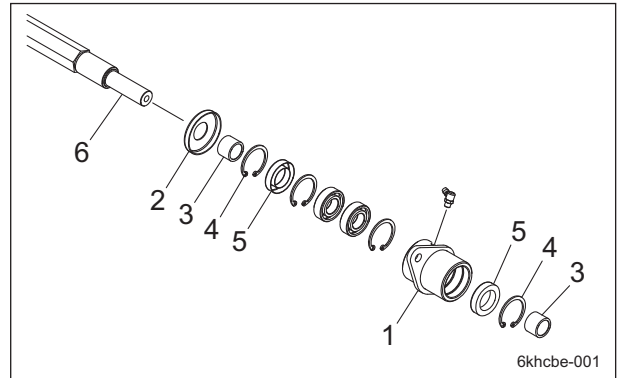

Groomer Shaft\_001

1	Groomer housing
2	Dust-proof cover
3	Collar
4	Stop ring
5	Oil seal
6	Groomer shaft

- [2] Remove the stop ring, bearings and grease nipple.

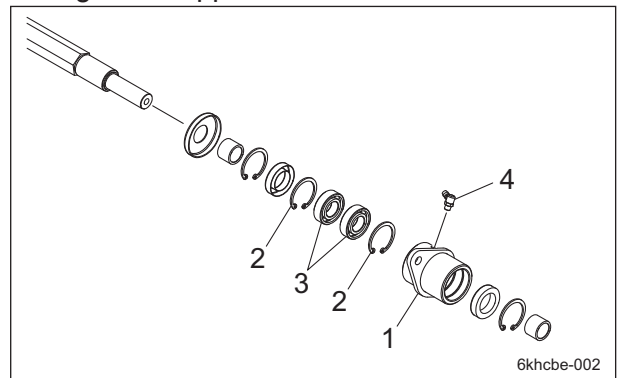

Groomer Shaft\_002

# Operating Machine and Mower Units

1	Groomer housing
2	Stop ring
3	Bearing
4	Grease nipple

4. Follow the steps below to disassemble the groomer shaft assy.

- [1] Remove the nuts on the groomer housing side.
- [2] Remove the collar and groomer blades in order.
- [3] Remove fixing nut A and fixing nut B.

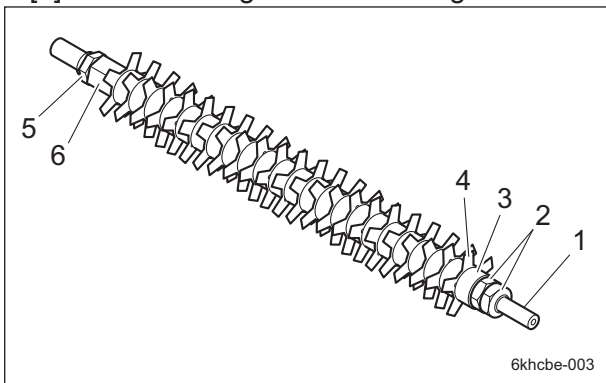

Groomer Shaft\_003

1	Groomer shaft (groomer housing side)
2	Nut
3	Collar
4	Groomer blade
5	Fixing nut A
6	Fixing nut B

5. Follow the steps below to disassemble the groomer adjustment bolt assy.

6. Remove the adjustment nut, washer, rod holder, spring holders, spring, pipe with adjustment screw, and adjustment pipe in order.

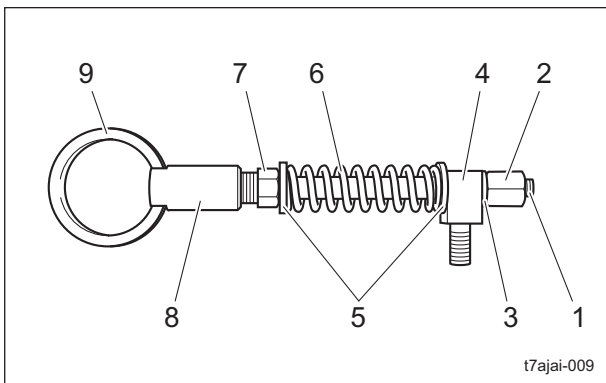

Groomer Shaft\_004

1	Groomer adjustment bolt assy
2	Adjustment nut
3	Washer
4	Rod holder
5	Spring holder
6	Spring
7	Pipe with adjustment screw
8	Adjustment pipe
9	Groomer adjustment bolt

7. Install the groomer adjustment bolt assy. For installation, reverse the disassembly steps.

8. Adjust the length of the spring of the height adjustment bolt to 45.0 mm (1.77 in) with the pipe with adjustment screw.

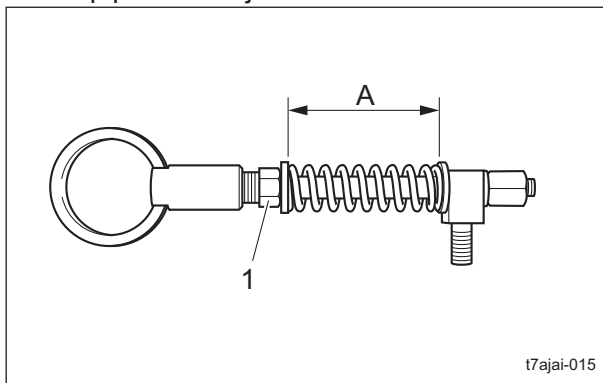

Groomer Shaft\_005

1	Pipe with adjustment screw
A	45.0 mm (1.77 in)

# Operating Machine and Mower Units

**Important**

Be careful not to damage the groomer shaft.

9. Follow the steps below to install the groomer shaft assy.

[1] Temporarily install fixing nut B and fixing nut A to the groomer shaft.

Fixing nut A is located approximately 10.0 mm (0.39 in) away from the threaded end (A).

[2] Insert 1 groomer blade.

[3] Turn up the groomer shaft.

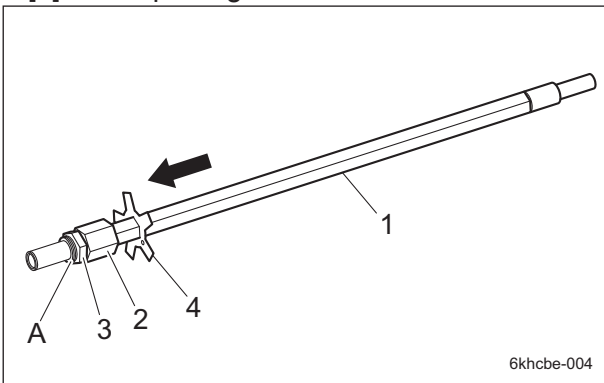

Groomer Shaft\_006

1	Groomer shaft
2	Fixing nut B
3	Fixing nut A
4	Groomer blade

Note:

Top view with the first groomer blade inserted onto the groomer shaft. Place the hole mark toward you

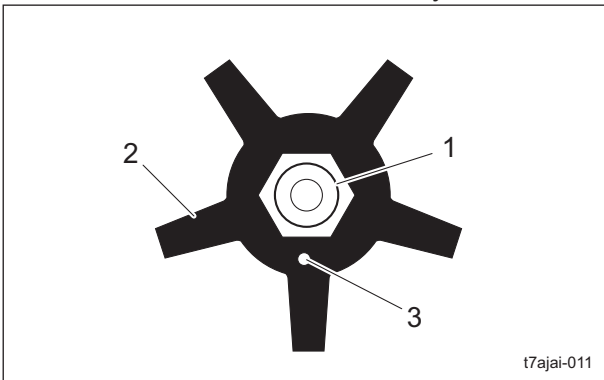

Groomer Shaft\_007

1	Groomer shaft
2	Groomer blade
3	Hole mark

**Important**

After inserting each groomer blade onto the groomer shaft, rotate the groomer shaft clockwise by one surface of the six shaft surfaces.

[4] Rotate the groomer shaft clockwise and insert the groomer blades and collars alternately onto the groomer shaft. The twist of the groomer blades must be the same as that of the blades of the reel cutter.

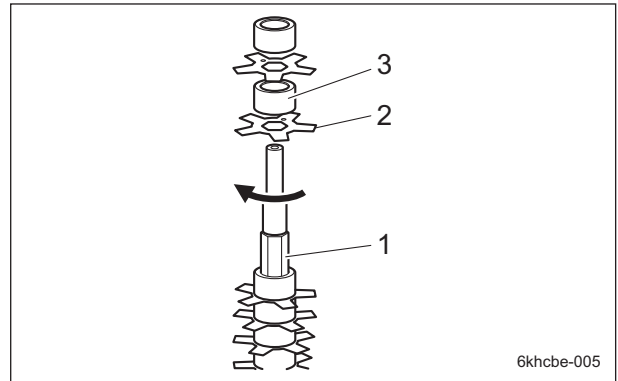

Groomer Shaft\_008

1	Groomer shaft
2	Groomer blade
3	Collar

[5] Install two nuts to the groomer shaft.

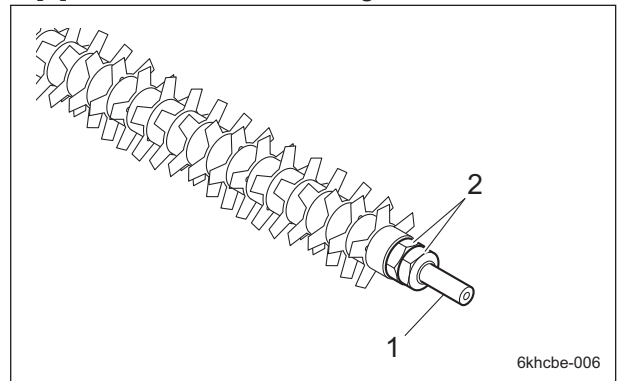

Groomer Shaft\_009

1	Groomer shaft
2	Nut

10. Follow the steps below to install the groomer housing.

# Operating Machine and Mower Units

**Important**

Be sure to replace the bearing and oil seal with new ones.

- [1] Apply a profuse amount of grease on new bearings and oil seals. For bearings, apply the grease until it overflows from the opposite side. Also apply a profuse amount of grease to the lip of the oil seal.

Note:

Use a bearing driver to drive in the bearings and oil seals.

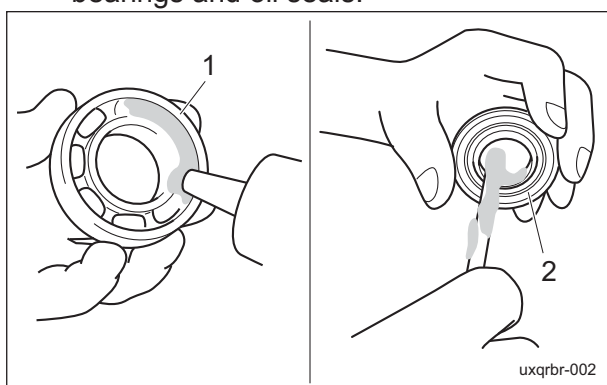

Groomer Shaft\_010

1	Bearing
2	Oil seal

- 11. Install stop ring A, bearing and stop ring A in order to the groomer housing.

- [1] Install the oil seal and stop ring B, and install the collar.
- [2] Follow the same steps to install them to the other side.
- [3] Install the grease nipple and dust-proof cover to the groomer housing.

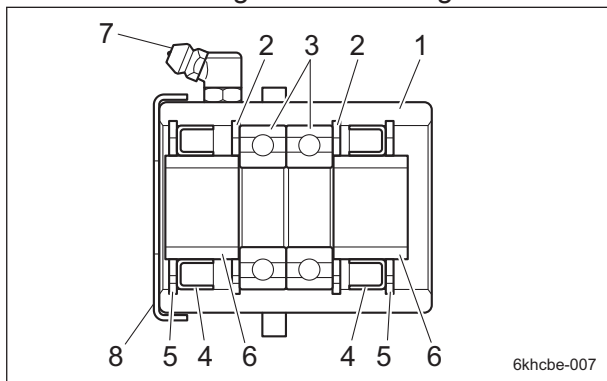

Groomer Shaft\_011

1	Groomer housing
2	Stop ring A
3	Bearing
4	Oil seal
5	Stop ring B
6	Collar
7	Grease nipple
8	Dust-proof cover

- 12. Install the groomer housing to the groomer shaft assy, and install the washer, spring washer and bolt.

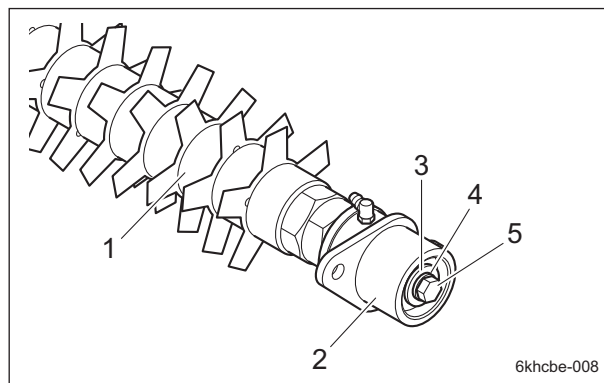

Groomer Shaft\_012

1	Groomer shaft assy
2	Groomer housing
3	Washer
4	Spring washer
5	Bolt

- 13. When installing the groomer shaft assy to the mower unit, be sure to adjust the nuts, fixing nut A and fixing nut B so that it fits into the grooves of the front roller.
- 14. Lock the nuts and fixing nut A and fixing nut B.

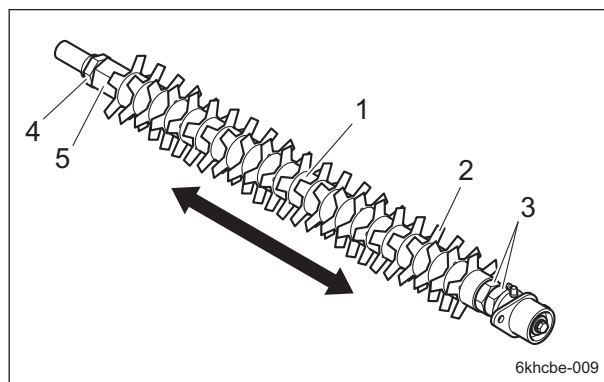

Groomer Shaft\_013

# Operating Machine and Mower Units

1	Groomer shaft assy
2	Groomer blade
3	Nut
4	Fixing nut A
5	Fixing nut B

## CR Brush Assy

CR Brush Assy (type with only CR brush installed)

**Note:**

Depending on the specifications, this function may not be available.

Wear of bearings due to frequent use and/or damage of bearing, etc. caused by invasion of water may prevent smooth rotation of the CR brush.

Inspect and replace the parts such as the oil seal and bearings.

- Check that there is no deformation or damage on the brush.
- Make sure that the brush shaft is not bent nor worn.
- Make sure that the brush frame and brush housing do not have any cracks.
- Make sure that the bearing receptacles of the brush frame and brush housing have no play.
- Make sure that there is no wear or damage of the belt.

**⚠ Caution**

"Tightening torques" (Page 3-5) See the list. Note that the Baroness product warranty may not apply to defects caused by incorrect or overtorque tightening, etc.

1. Remove the CR brush assy.  
"Removal of CR Brush Assy (type with only CR brush installed)" (Page 4-32) "Removal of CR Brush Assy (type with groomer + CR brush installed together)" (Page 4-33)
2. Loosen the tension pulley shaft, and remove the belt from the driving pulley and brush pulley.

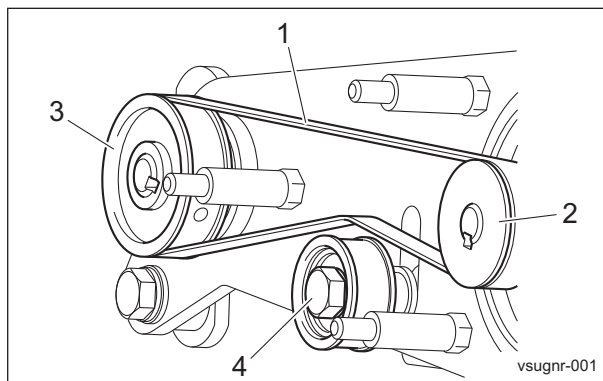

CR Brush Assy (type with only CR brush installed)\_001

1	Belt
2	Driving pulley
3	Brush pulley
4	Tension pulley shaft

3. Remove the brush pulley hollow screws.

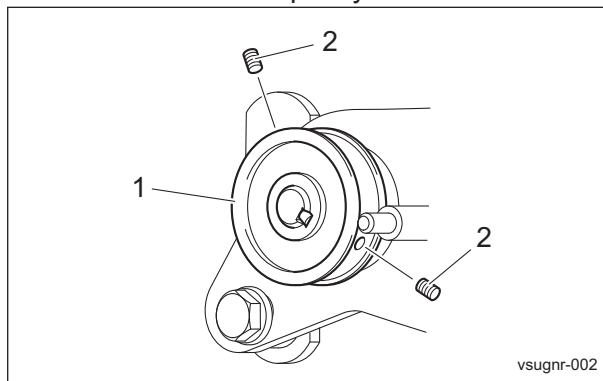

CR Brush Assy (type with only CR brush installed)\_002

1	Brush pulley
2	Hollow screw

4. Remove the brush pulley from the brush shaft.

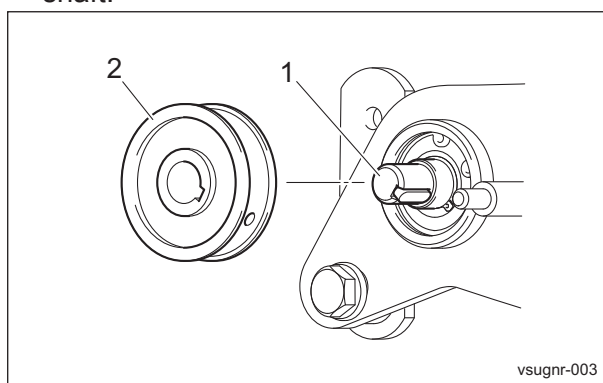

CR Brush Assy (type with only CR brush installed)\_003

1	Brush shaft
2	Brush pulley

# Operating Machine and Mower Units

5. Remove the key from the brush shaft.

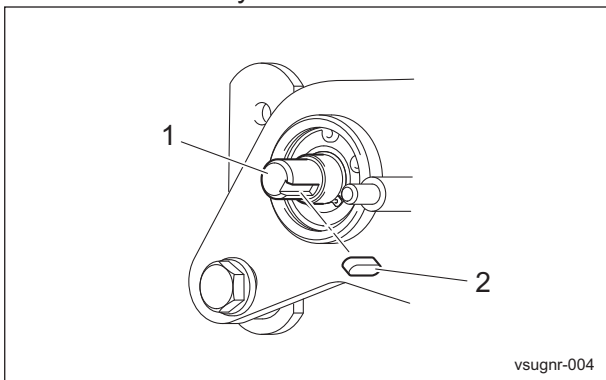

CR Brush Assy (type with only CR brush installed)\_004

1	Brush shaft
2	Key

6. Remove the stop ring from the brush shaft.

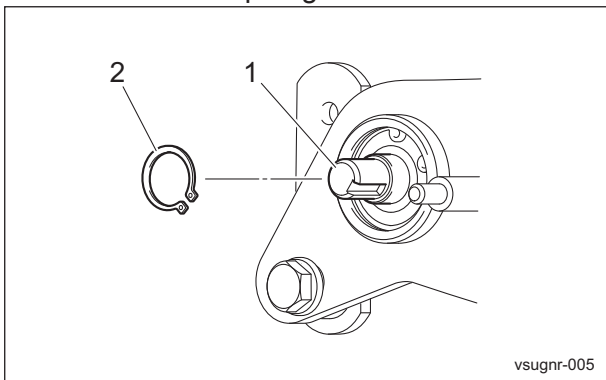

CR Brush Assy (type with only CR brush installed)\_005

1	Brush shaft
2	Stop ring

7. Tap the end of the brush shaft with a plastic hammer or similar tool, and remove the brush frame.

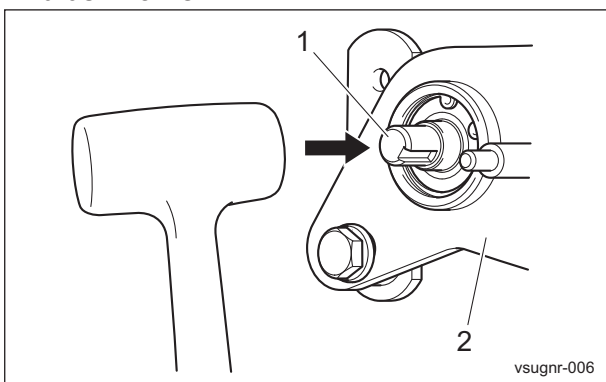

CR Brush Assy (type with only CR brush installed)\_006

1	Brush shaft
2	Brush frame

8. Follow the steps below to disassemble the brush frame.

[1] Remove the stop ring from the housing frame.

[2] Remove the bearing, collar, and bearing in order.

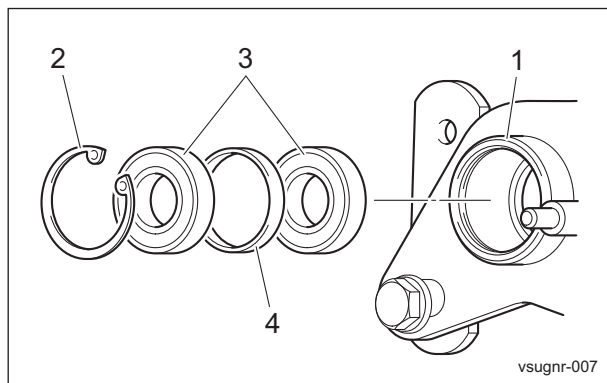

CR Brush Assy (type with only CR brush installed)\_007

1	Brush frame
2	Stop ring
3	Bearing
4	Collar

[3] Loosen the tension pulley shaft, and remove it from the screw washer.

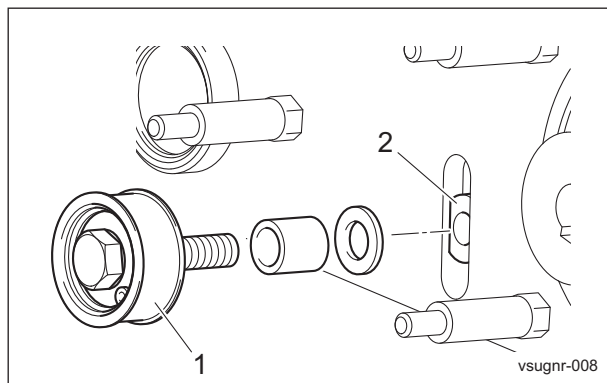

CR Brush Assy (type with only CR brush installed)\_008

1	Tension pulley shaft
2	Screw washer

# Operating Machine and Mower Units

[4] Tap the end of the tension pulley shaft with a plastic hammer or similar tool, and remove the tension pulley.

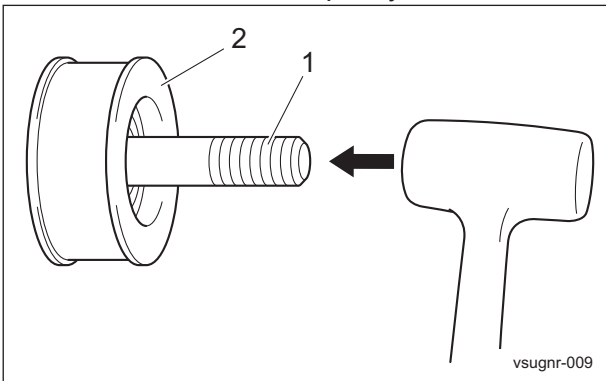

CR Brush Assy (type with only CR brush installed)\_009

1	Tension pulley shaft
2	Tension pulley

[5] Remove the stop ring from the tension pulley.

[6] Remove the bearing.

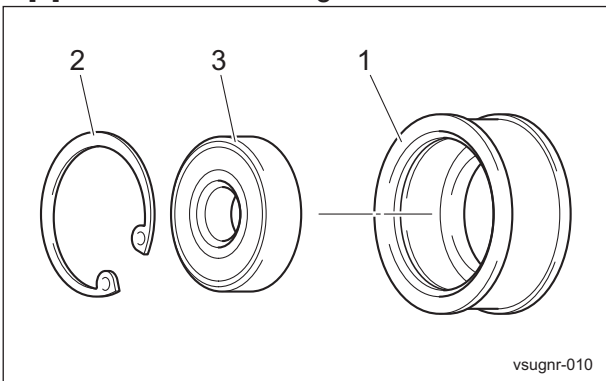

CR Brush Assy (type with only CR brush installed)\_010

1	Tension pulley
2	Stop ring
3	Bearing

[7] Remove the hollow screws from the driving pulley.

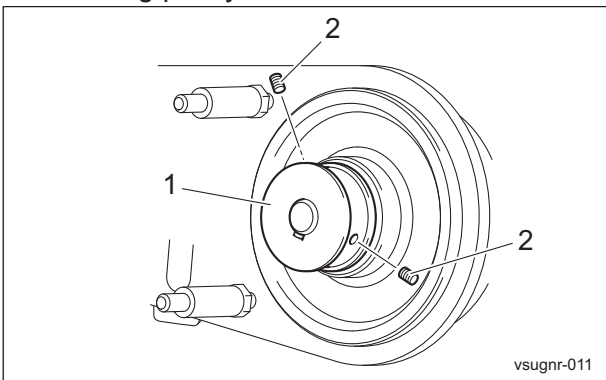

CR Brush Assy (type with only CR brush installed)\_011

1	Driving pulley
2	Hollow screw

[8] Remove the drive pulley from the drive shaft.

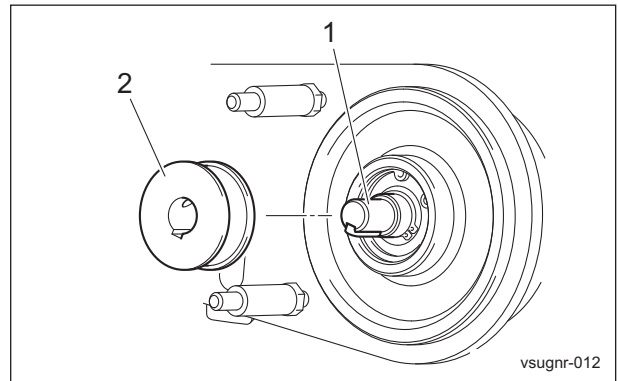

CR Brush Assy (type with only CR brush installed)\_012

1	Drive shaft
2	Driving pulley

[9] Remove the key from the drive shaft.

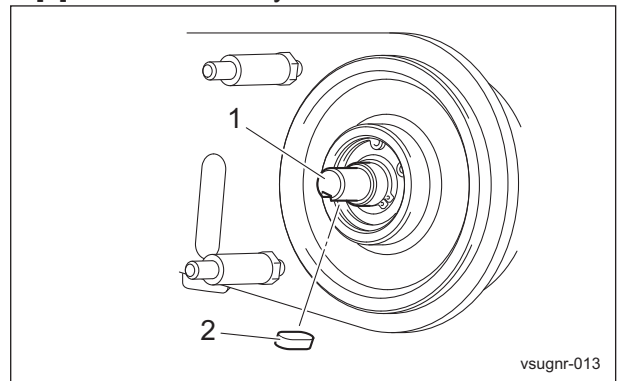

CR Brush Assy (type with only CR brush installed)\_013

1	Drive shaft
2	Key

[10] Remove the stop ring from the drive shaft.

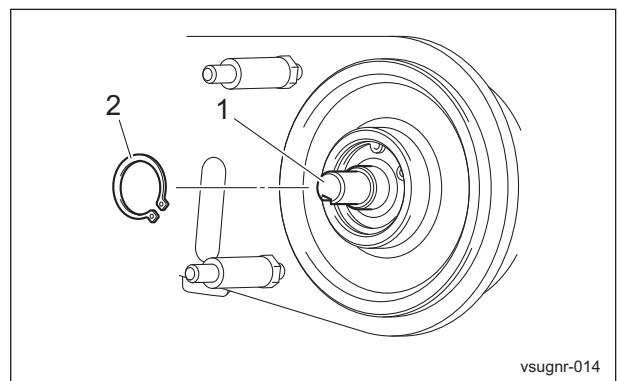

CR Brush Assy (type with only CR brush installed)\_014

1	Drive shaft
2	Stop ring

# Operating Machine and Mower Units

[11] Tap the end of the drive shaft with a plastic hammer or similar tool, and remove the brush frame.

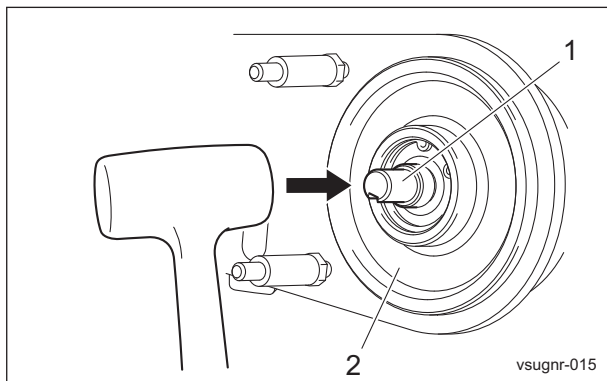

CR Brush Assy (type with only CR brush installed)\_015

1	Drive shaft
2	Brush frame

[12] Remove the stop ring from the brush frame.

[13] Remove the bearing, collar, and bearing in order.

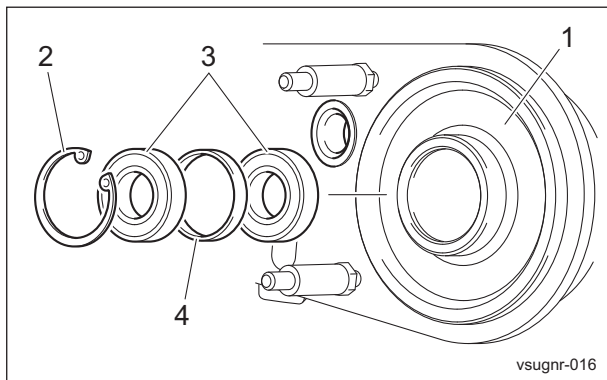

CR Brush Assy (type with only CR brush installed)\_016

1	Brush frame
2	Stop ring
3	Bearing
4	Collar

[14] Remove the O-ring from the brush frame groove.

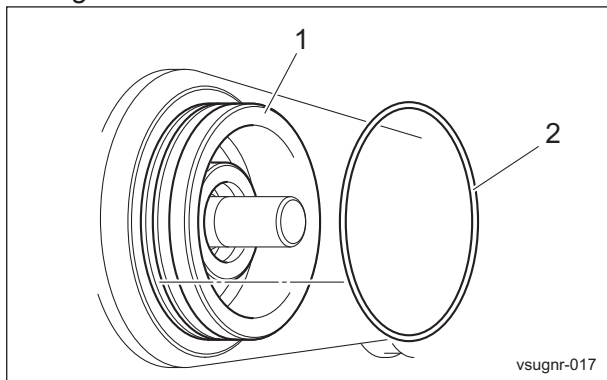

CR Brush Assy (type with only CR brush installed)\_017

1	Brush frame
2	O-ring

9. Tap the end of the brush shaft with a plastic hammer or similar tool, and remove the brush housing.

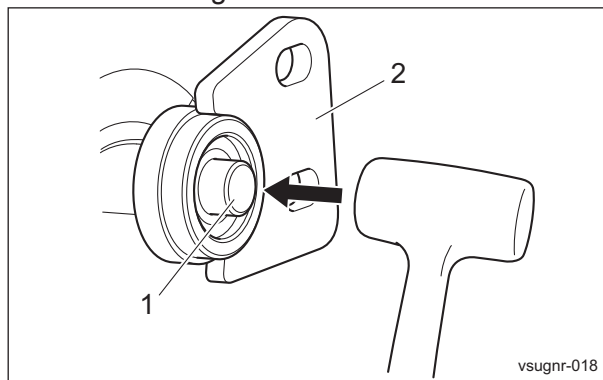

CR Brush Assy (type with only CR brush installed)\_018

1	Brush shaft
2	Brush housing

10. Follow the steps below to disassemble the brush housing.

[1] Remove the stop ring from the brush housing.

[2] Remove the bearing.

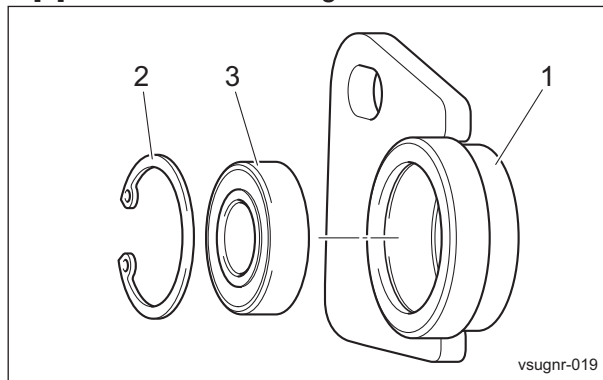

CR Brush Assy (type with only CR brush installed)\_019

1	Brush housing
2	Stop ring
3	Bearing

# Operating Machine and Mower Units

**Important**  
 Replace deteriorated, deformed, or worn parts with new ones.

**Important**  
 Be careful not to cause damage or deformation to the brush.

**Important**  
 Be sure to replace the bearing and O-ring with a new ones.

**Important**  
 The stop ring has a specific installation orientation. Install it in the correct orientation.

For installation, reverse the disassembly steps.

1. Follow the steps below to install the brush housing.

[1] Install the bearing to the brush housing.

Note:  
 Use a bearing driver to drive in the bearing.

[2] Attach the stop ring.

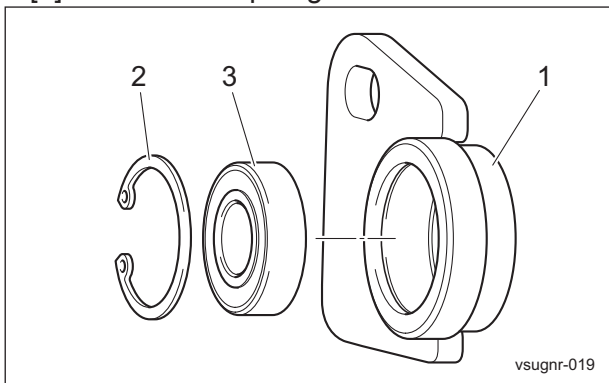

CR Brush Assy (type with only CR brush installed)\_020

1	Brush housing
2	Stop ring
3	Bearing

2. Apply grease to the end of the brush shaft, and install the brush shaft to the brush housing.

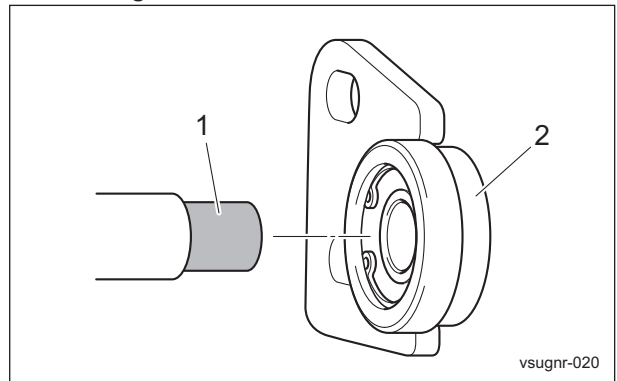

CR Brush Assy (type with only CR brush installed)\_021

1	Brush shaft
2	Brush housing

3. Follow the steps below to install the brush frame.

**Important**  
 The stop ring has a specific installation orientation. Install it in the correct orientation.

[1] Drive the bearing, collar and bearing in order to the brush frame drive shaft.

Note:  
 Use a bearing driver to drive in the bearing.

[2] Attach the stop ring.

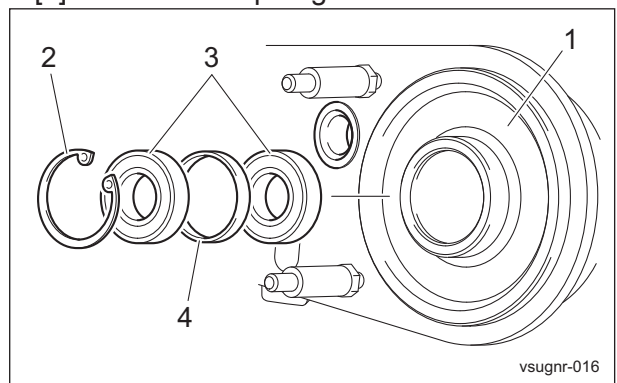

CR Brush Assy (type with only CR brush installed)\_022

1	Brush frame
2	Stop ring
3	Bearing
4	Collar

# Operating Machine and Mower Units

[3] Apply grease to the drive shaft, tap the end of the drive shaft with a plastic hammer or similar tool, and install it to the brush frame.

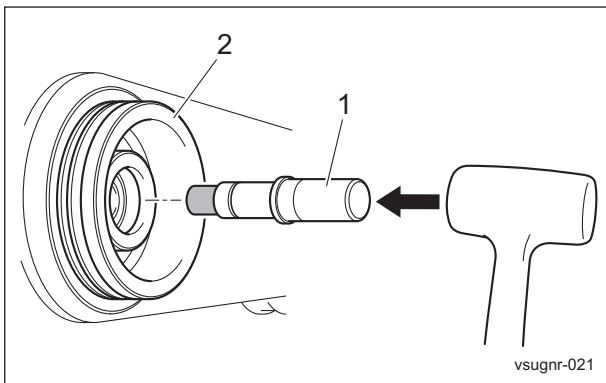

CR Brush Assy (type with only CR brush installed)\_023

1	Drive shaft
2	Brush frame

[4] Install the stop ring to the drive shaft groove.

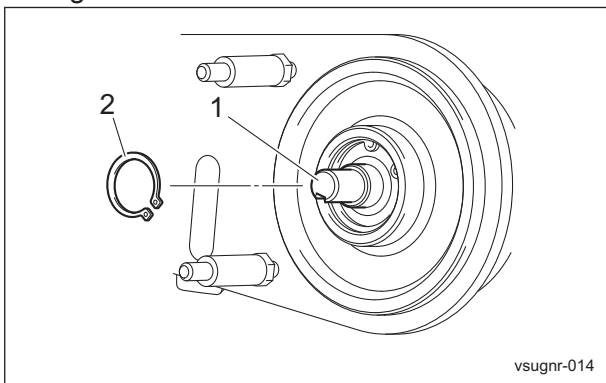

CR Brush Assy (type with only CR brush installed)\_024

1	Drive shaft
2	Stop ring

[5] Install the key to the drive shaft keyed groove.

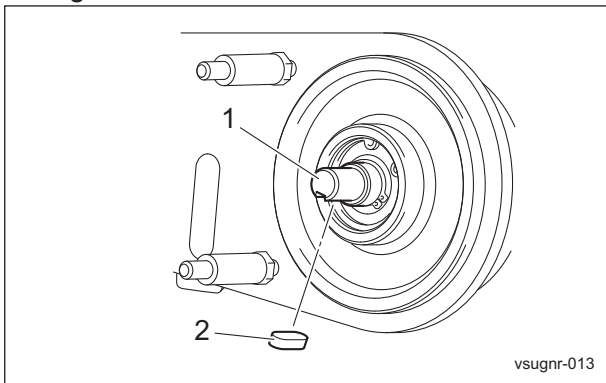

CR Brush Assy (type with only CR brush installed)\_025

1	Drive shaft
2	Key

[6] Install the drive pulley to the drive shaft.

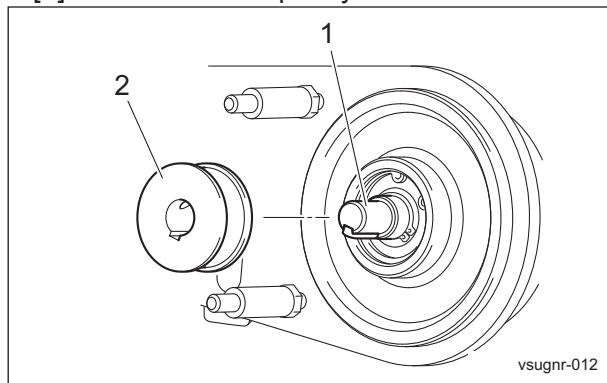

CR Brush Assy (type with only CR brush installed)\_026

1	Drive shaft
2	Driving pulley

[7] Install the hollow screws to the driving pulley.

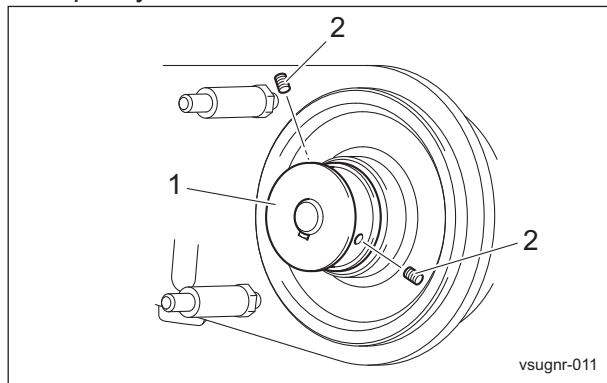

CR Brush Assy (type with only CR brush installed)\_027

1	Driving pulley
2	Hollow screw

[8] Apply grease to the base of the tension pulley shaft, and drive the tension pulley shaft to the tension pulley assy with a plastic hammer or similar tool.

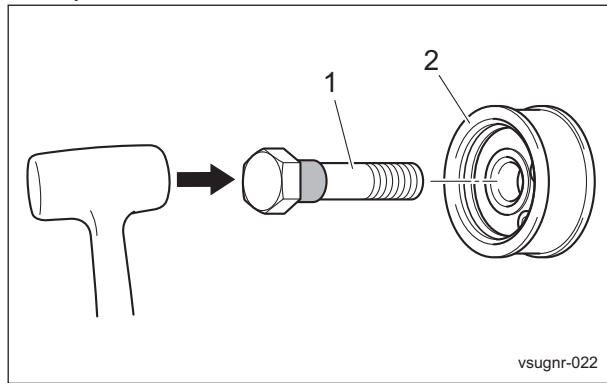

CR Brush Assy (type with only CR brush installed)\_028

1	Tension pulley shaft
2	Tension pulley assy

# Operating Machine and Mower Units

[9] Install the collar and disc spring washer to the tension pulley shaft.

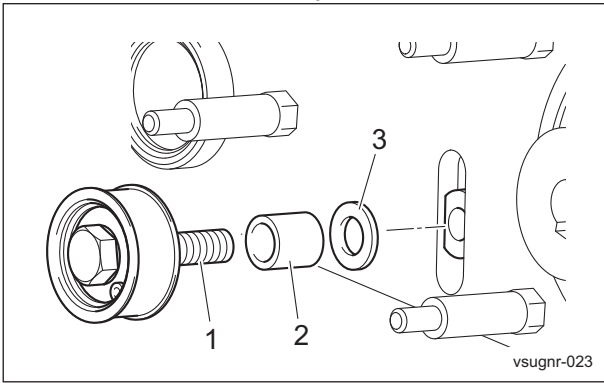

CR Brush Assy (type with only CR brush installed)\_029

1	Tension pulley shaft
2	Collar
3	Disc spring washer

[10] Insert the tension pulley shaft into the brush frame groove, and temporarily install the plate and washer in order.

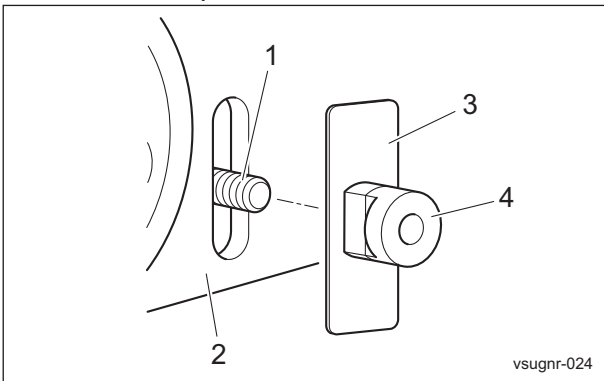

CR Brush Assy (type with only CR brush installed)\_030

1	Tension pulley shaft
2	Brush frame
3	Plate
4	Screw washer

[11] Install the bearing, collar and bearing in order to the brush frame.

Note:

Use a bearing driver to drive in the bearing.

[12] Attach the stop ring.

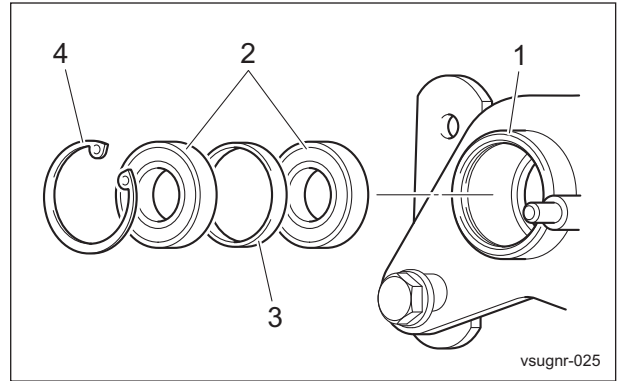

CR Brush Assy (type with only CR brush installed)\_031

1	Housing frame
2	Bearing
3	Collar
4	Stop ring

4. Apply grease to the shaded section of the brush shaft, tap the other end of the brush shaft with a plastic hammer or similar tool, and install it to the brush frame.

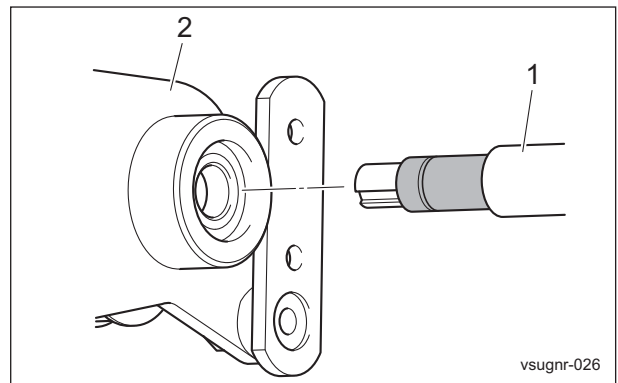

CR Brush Assy (type with only CR brush installed)\_032

1	Brush shaft
2	Brush frame

5. Install the stop ring to the brush shaft groove.

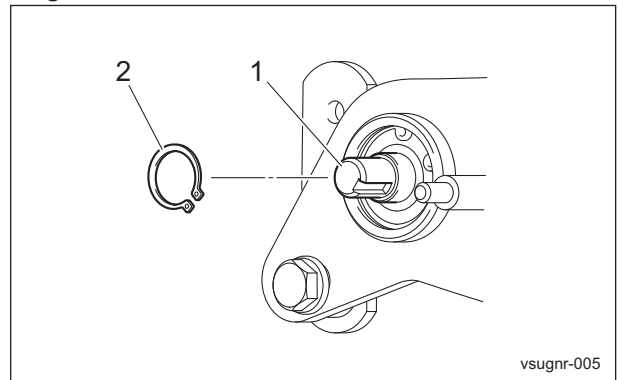

CR Brush Assy (type with only CR brush installed)\_033

# Operating Machine and Mower Units

1	Brush shaft
2	Stop ring

6. Install the key to the brush shaft.

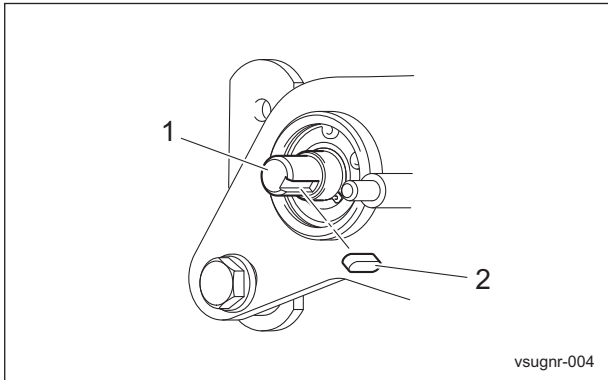

CR Brush Assy (type with only CR brush installed)\_034

1	Brush shaft
2	Key

7. Install the brush pulley by aligning its keyed groove with the brush shaft key.

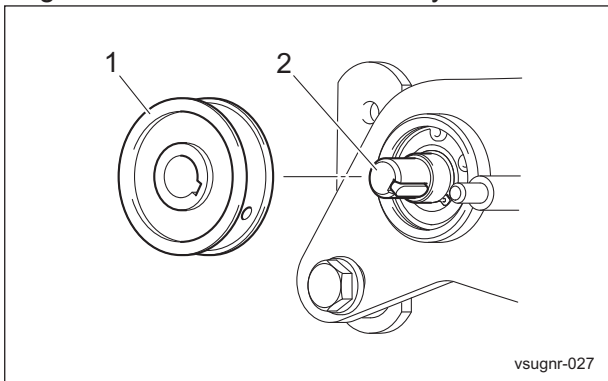

CR Brush Assy (type with only CR brush installed)\_035

1	Brush pulley
2	Brush shaft

8. Install the hollow screws to the brush pulley.

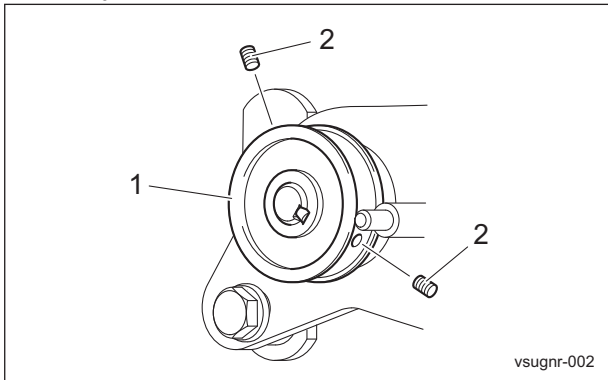

CR Brush Assy (type with only CR brush installed)\_036

1	Brush pulley
2	Hollow screw

9. Apply grease to the O-ring, and install it to the brush frame groove.

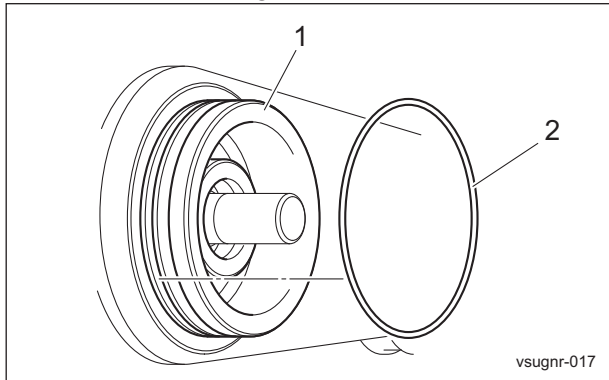

CR Brush Assy (type with only CR brush installed)\_037

1	O-ring
2	Brush frame

10. Install the belt to the driving pulley and brush pulley.

11. Adjust the belt tension.

The belt tension is appropriate when there is 5.0 - 6.0 mm (0.197 - 0.236 in) of slack when the belt is pressed lightly by finger at 10.0 N (1.0 kgf) around the center section between the belt pulleys.

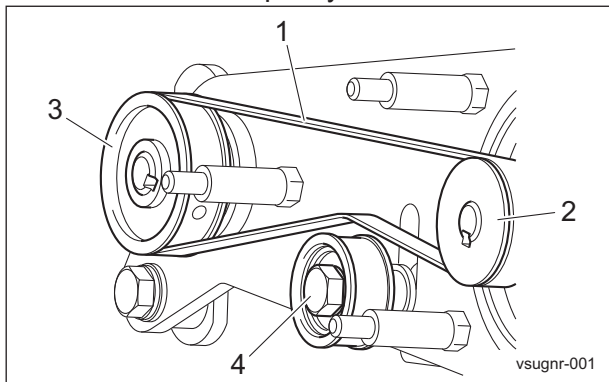

CR Brush Assy (type with only CR brush installed)\_038

1	Belt
2	Driving pulley
3	Brush pulley
4	Tension pulley shaft

# Operating Machine and Mower Units

CR Brush Assy (type with groomer + CR brush installed together)

**Note:**

- Depending on the specifications, this function may not be available.
- Wear of bearings due to frequent use and/or damage of bearing, etc. caused by invasion of water may prevent smooth rotation of the CR brush.
- Inspect and replace the parts such as the oil seal and bearings.
- Check that there is no deformation or damage on the brush.
  - Make sure that the brush shaft is not bent nor worn.
  - Make sure that the brush frame and brush housing do not have any cracks.
  - Make sure that there is no play in the tension lever.
  - Make sure that the bearing receptacles of the brush frame and brush housing have no play.
  - Make sure that the bearings receptacle of the groomer housing has no play.
  - Make sure that there is no wear or damage of the belt.

1	Tension adjustment bolt
2	Belt

2. Remove the CR brush assy.  
"Removal of CR Brush Assy (type with only CR brush installed)" (Page 4-32) "Removal of CR Brush Assy (type with groomer + CR brush installed together)" (Page 4-33)
3. Remove the brush pulley hollow screws.

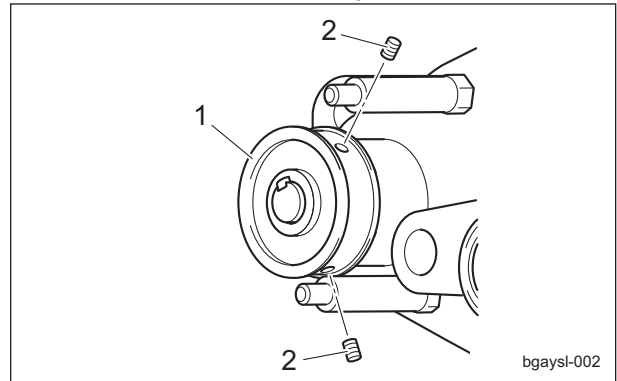

CR Brush Assy (type with groomer + CR brush installed together)\_002

1	Brush pulley
2	Hollow screw

4. Remove the brush pulley from the brush shaft.

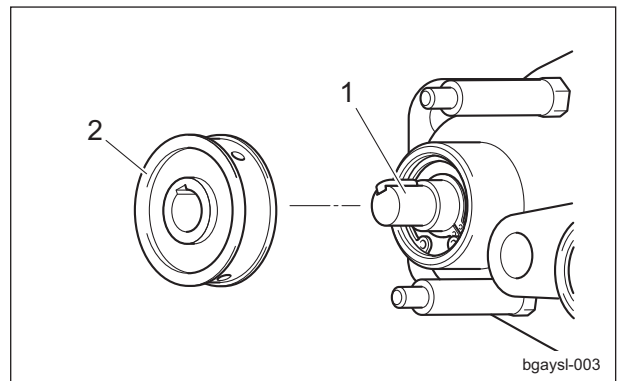

CR Brush Assy (type with groomer + CR brush installed together)\_003

1	Brush shaft
2	Brush pulley

**Caution**

"Tightening torques" (Page 3-5) See the list. Note that the Baroness product warranty may not apply to defects caused by incorrect or overtightening, etc.

1. Loosen the tension adjustment bolt of the tension spring applying tension to the belt, and remove the belt.

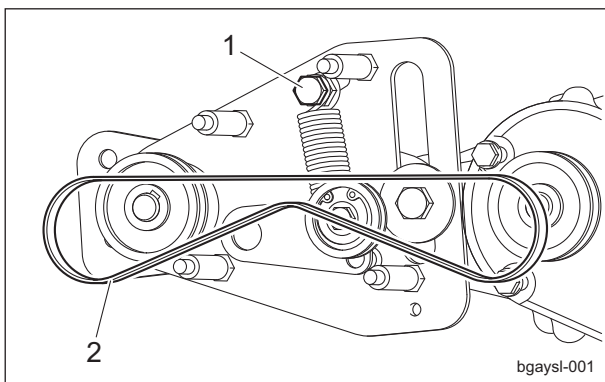

CR Brush Assy (type with groomer + CR brush installed together)\_001

# Operating Machine and Mower Units

5. Remove the key from the brush shaft.

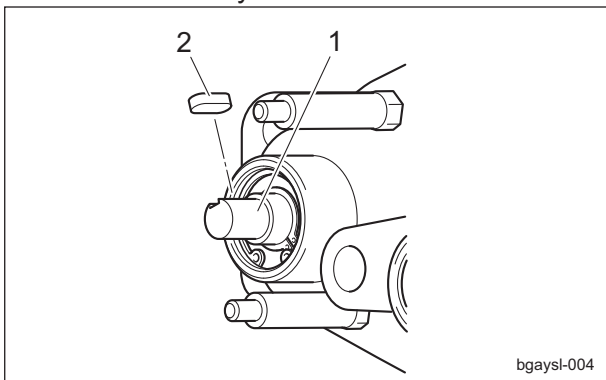

CR Brush Assy (type with groomer + CR brush installed together)\_004

1	Brush shaft
2	Key

6. Remove the stop ring from the brush shaft.

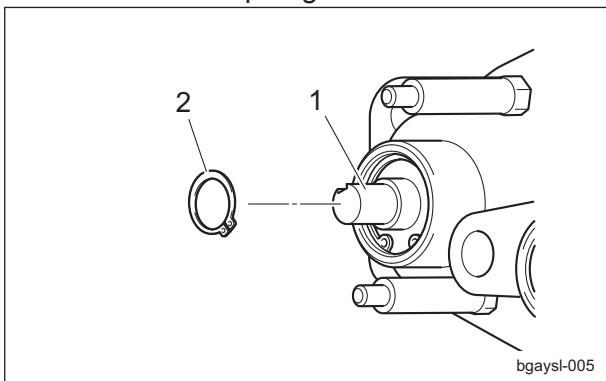

CR Brush Assy (type with groomer + CR brush installed together)\_005

1	Brush shaft
2	Stop ring

7. Tap the end of the brush shaft with a plastic hammer or similar tool, and remove it from the brush frame.

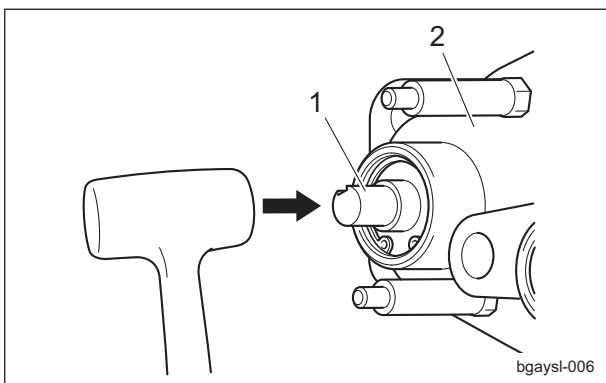

CR Brush Assy (type with groomer + CR brush installed together)\_006

1	Brush shaft
2	Brush frame

8. Follow the steps below to disassemble the brush frame.

[1] Remove the stop ring from the brush frame.

[2] Remove the bearing, collar, and bearing in order.

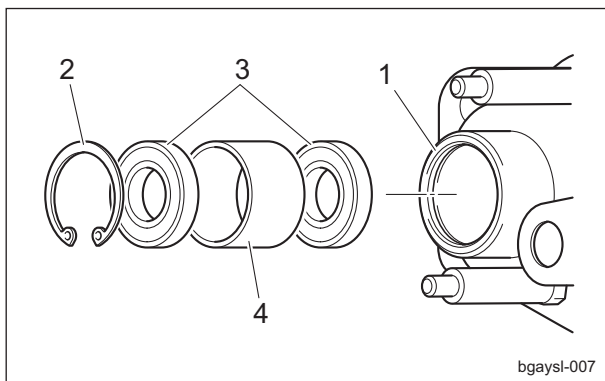

CR Brush Assy (type with groomer + CR brush installed together)\_007

1	Brush frame
2	Stop ring
3	Bearing
4	Collar

[3] Remove the grease nipple from the tension lever.

[4] Remove the stop ring.

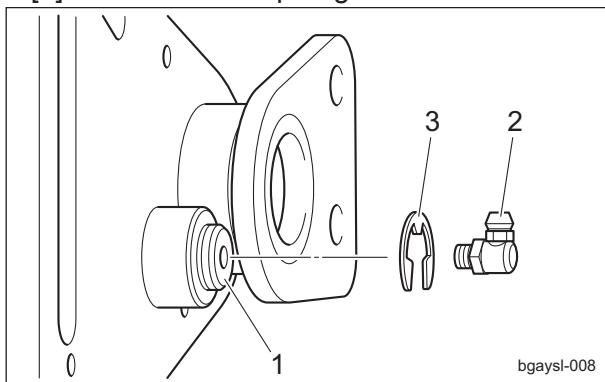

CR Brush Assy (type with groomer + CR brush installed together)\_008

1	Tension lever
2	Grease nipple
3	Stop ring

# Operating Machine and Mower Units

[5] Remove the tension lever from the brush frame.

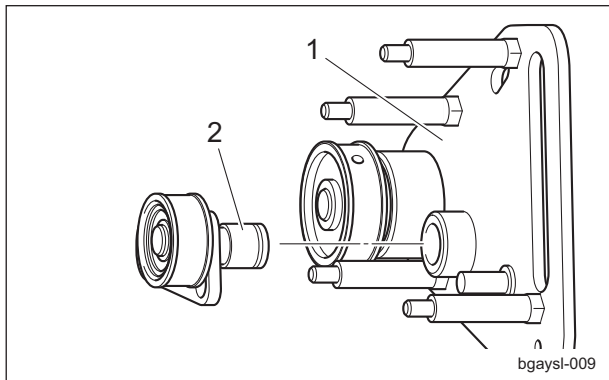

CR Brush Assy (type with groomer + CR brush installed together)\_009

1	Brush frame
2	Tension lever

[6] Remove the stop ring from the tension pulley shaft.

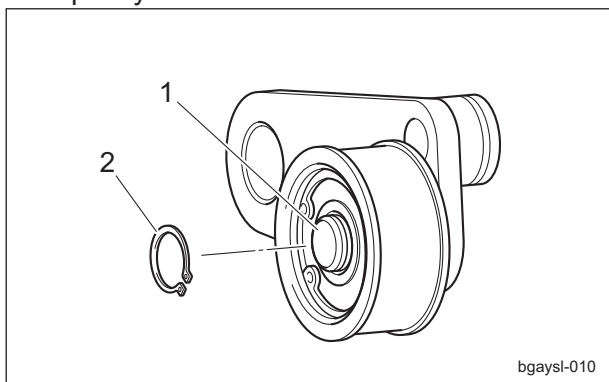

CR Brush Assy (type with groomer + CR brush installed together)\_010

1	Tension pulley shaft
2	Stop ring

[7] Remove the tension pulley assy from the tension lever.

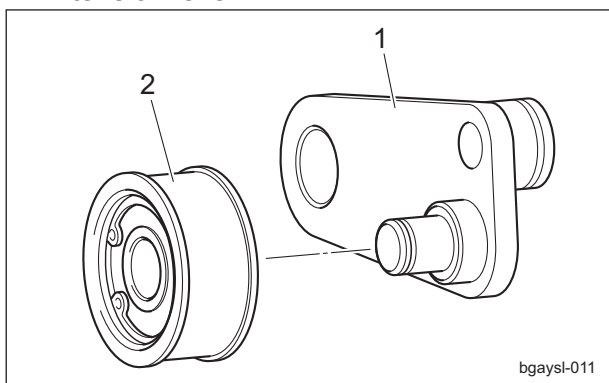

CR Brush Assy (type with groomer + CR brush installed together)\_011

1	Tension lever
2	Tension pulley assy

[8] Remove the stop ring from the tension pulley.

[9] Remove the bearing.

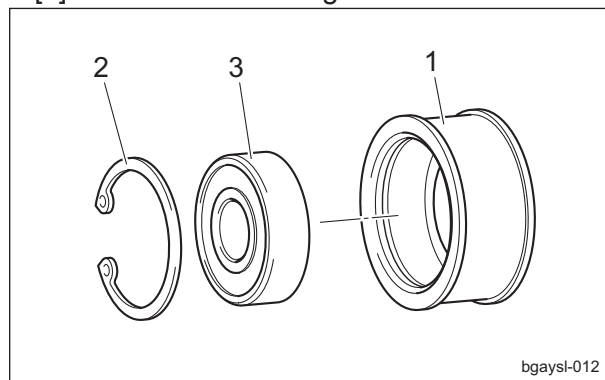

CR Brush Assy (type with groomer + CR brush installed together)\_012

1	Tension pulley
2	Stop ring
3	Bearing

9. Tap the end of the brush shaft with a plastic hammer or similar tool, and remove it from the brush housing.

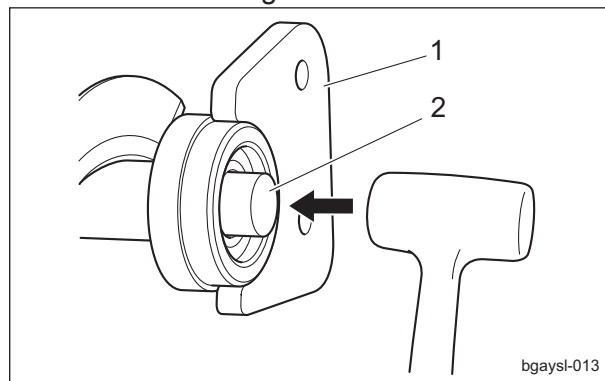

CR Brush Assy (type with groomer + CR brush installed together)\_013

1	Brush housing
2	Brush shaft

10. Remove the stop ring from the brush housing.

# Operating Machine and Mower Units

## 11. Remove the bearing.

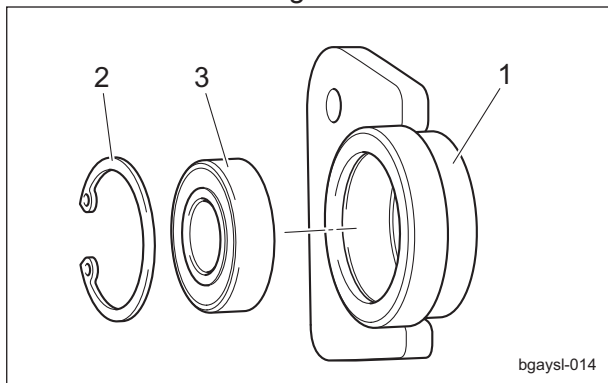

CR Brush Assy (type with groomer + CR brush installed together)\_014

1	Brush housing
2	Stop ring
3	Bearing

**Important**

Replace deteriorated, deformed, or worn parts with new ones.

**Important**

Be careful not to cause damage or deformation to the brush.

**Important**

Be sure to replace the bearing with a new one.

**Important**

The stop ring has a specific installation orientation. Install it in the correct orientation.

For installation, reverse the disassembly steps.

1. Follow the steps below to install the brush housing.

[1] Install the bearing to the brush housing.

Note:

Use a bearing driver to drive in the bearing.

## [2] Attach the stop ring.

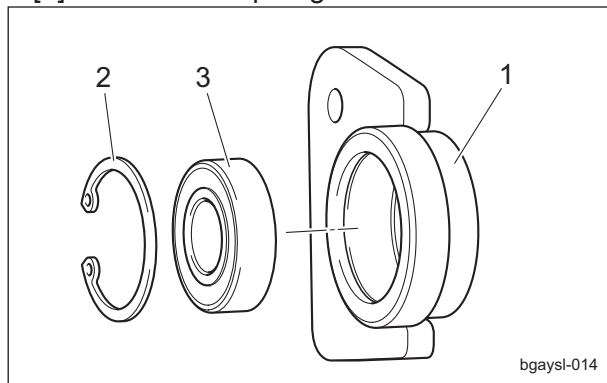

CR Brush Assy (type with groomer + CR brush installed together)\_015

1	Brush housing
2	Stop ring
3	Bearing

2. Apply grease to the end of the brush shaft, and install the brush shaft to the brush housing.

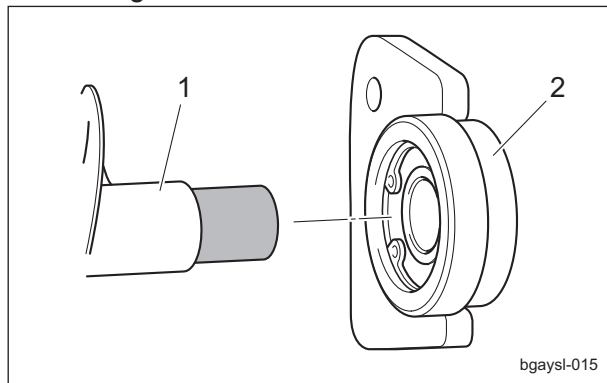

CR Brush Assy (type with groomer + CR brush installed together)\_016

1	Brush shaft
2	Brush housing

3. Follow the steps below to install the housing frame.

[1] Install the bearing to the tension pulley.

Note:

Use a bearing driver to drive in the bearing.

# Operating Machine and Mower Units

[2] Attach the stop ring.

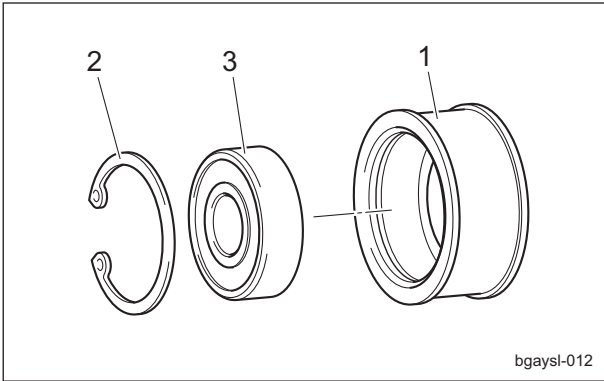

CR Brush Assy (type with groomer + CR brush installed together)\_017

1	Tension pulley
2	Stop ring
3	Bearing

[3] Install the tension pulley to the tension lever.

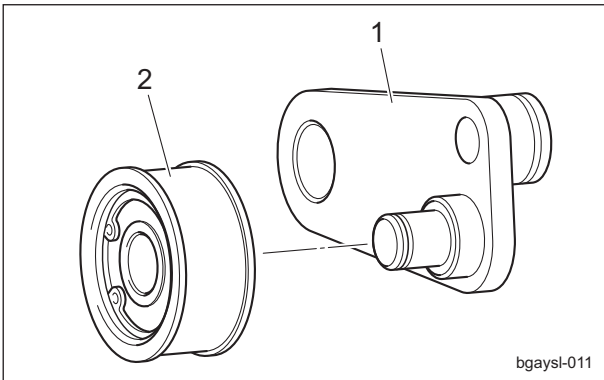

CR Brush Assy (type with groomer + CR brush installed together)\_018

1	Tension lever
2	Tension pulley

[4] Install the stop ring to the tension pulley shaft.

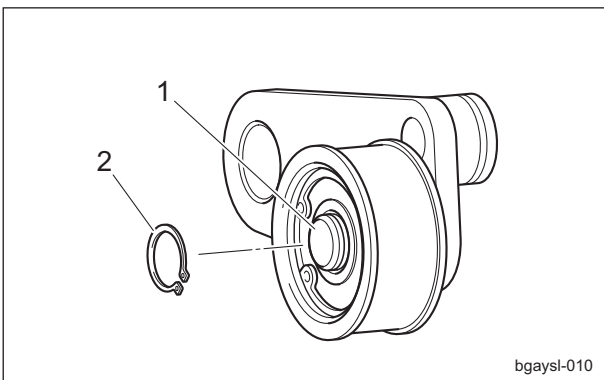

CR Brush Assy (type with groomer + CR brush installed together)\_019

1	Tension pulley shaft
2	Stop ring

[5] Apply grease to the shaft section of the tension lever shaft, and install it to the brush frame.

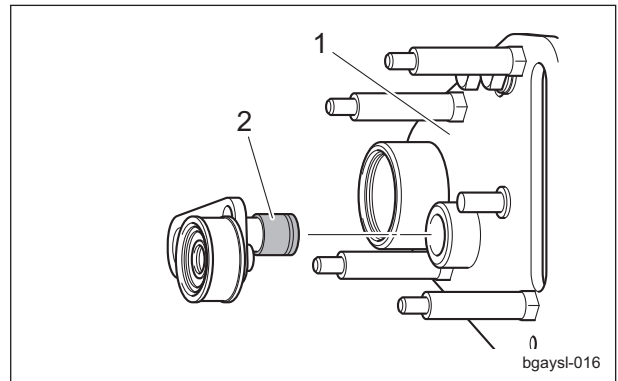

CR Brush Assy (type with groomer + CR brush installed together)\_020

1	Brush frame
2	Tension lever

[6] Install the stop ring to the tension lever.

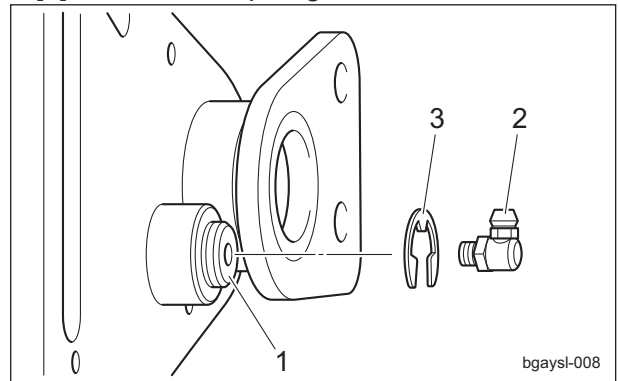

CR Brush Assy (type with groomer + CR brush installed together)\_021

1	Tension lever
2	Grease nipple
3	Stop ring

# Operating Machine and Mower Units

**Important**

The grease nipple has a specific installation direction.

Check that the grease nipple is in the orientation shown in the figure, and install it.

[7] Install the grease nipple.

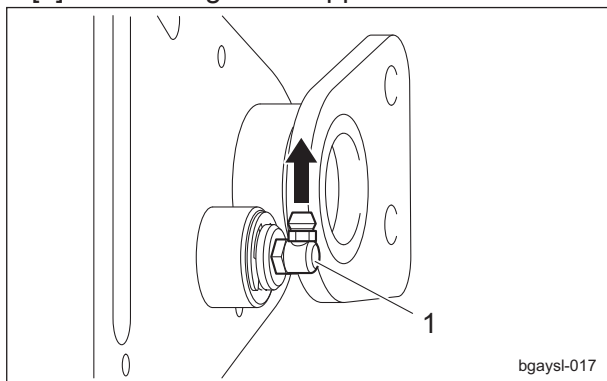

CR Brush Assy (type with groomer + CR brush installed together)\_022

1	Grease nipple
---	---------------

[8] Install the bearing, collar and bearing in order to the brush frame.

Note:  
Use a bearing driver to drive in the bearing.

[9] Attach the stop ring.

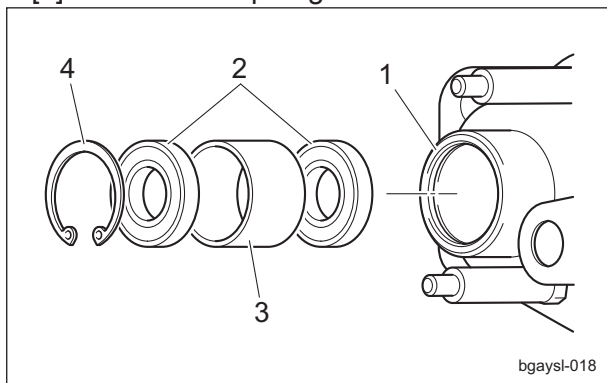

CR Brush Assy (type with groomer + CR brush installed together)\_023

1	Brush frame
2	Bearing
3	Collar
4	Stop ring

4. Apply grease to the end of the brush shaft, tap the other end of the brush shaft with a plastic hammer or similar tool, and install it to the brush frame.

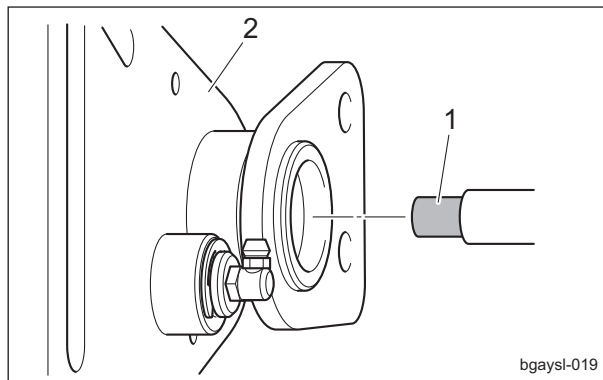

CR Brush Assy (type with groomer + CR brush installed together)\_024

1	Brush shaft
2	Brush frame

5. Install the stop ring to the brush shaft.

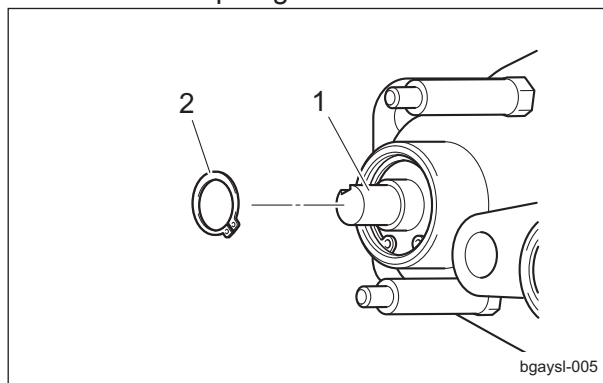

CR Brush Assy (type with groomer + CR brush installed together)\_025

1	Brush shaft
2	Stop ring

6. Install the key to the brush shaft.

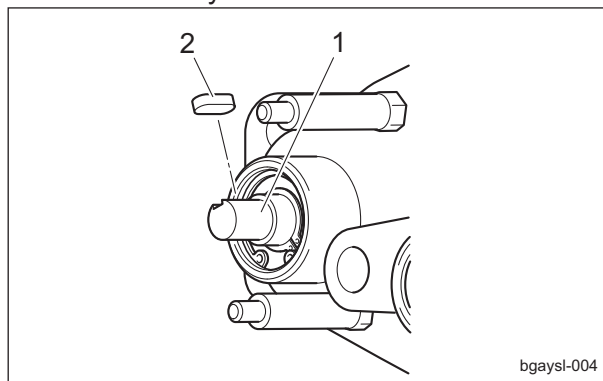

CR Brush Assy (type with groomer + CR brush installed together)\_026

1	Brush shaft
2	Key

# Operating Machine and Mower Units

7. Install it by aligning with the brush pulley keyed groove and the brush shaft key.

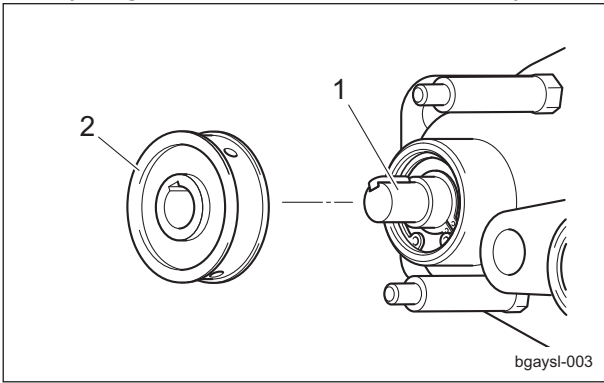

CR Brush Assy (type with groomer + CR brush installed together)\_027

1	Brush shaft
2	Brush pulley

8. Install the hollow screws to the brush pulley.

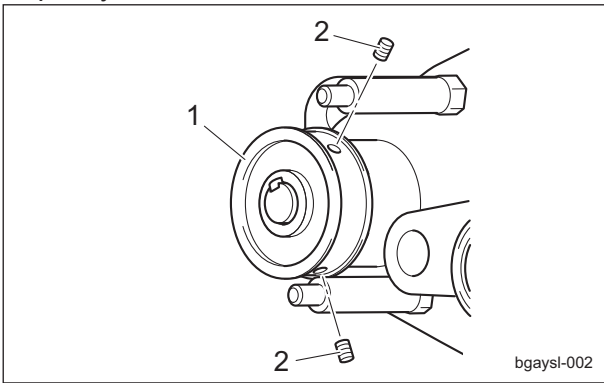

CR Brush Assy (type with groomer + CR brush installed together)\_028

1	Brush pulley
2	Hollow screw

9. Install the CR brush assy.  
"Installation of CR Brush Assy" (Page 4-34)

10. Install the belt to the driving pulley and brush pulley.

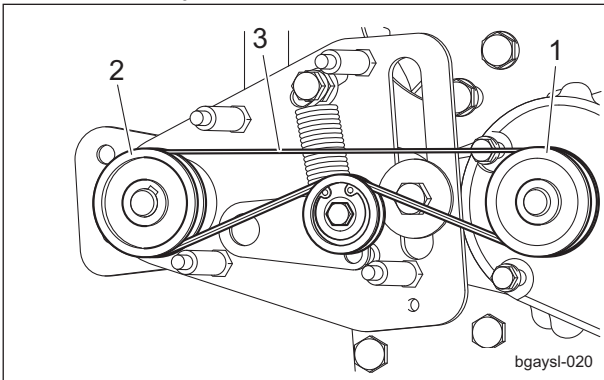

CR Brush Assy (type with groomer + CR brush installed together)\_029

1	Driving pulley
2	Brush pulley
3	Belt

11. Adjust the belt tension.

The belt tension is appropriate when the length of the spring coil is 63.0 - 65.0 mm (2.48 - 2.56 in).

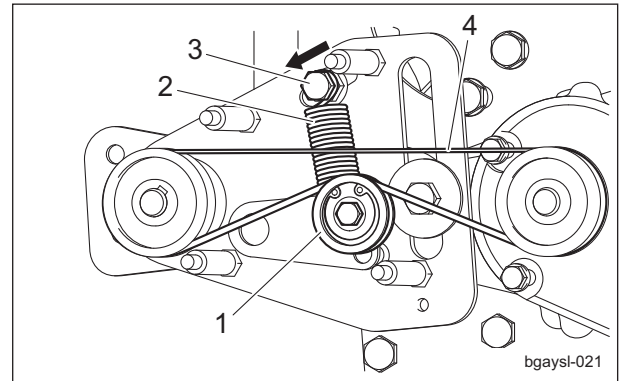

CR Brush Assy (type with groomer + CR brush installed together)\_030

1	Tension pulley
2	Spring
3	Tension adjustment bolt
4	Belt

**Relating to Operating Machine and  
Mower Unit ..... Page 5-2**

# Troubleshooting

## Relating to Operating Machine and Mower Unit

Problem	Cause	Reference
Blade engagement gets out of order	Insufficient tension of the spring on the pipe with the cutter adjustment screw	Operating machine and mower units - Removal and installation of each section - Reel cutter
	Adhesion or play of the up/down movement part of the reel housing	Operating machine and mower units - Inspection and repair of each section - Reel housing
	Malfunction of the reel bearing	Operating machine and mower units - Inspection and repair of each section - Reel housing Replacement of the bearing
	Wear of the reel shaft	Operating machine and mower units - Inspection and repair of each section - Reel cutter
	Insufficient tightening of the reel nuts	Operating machine and mower units - Removal and installation of each section - Reel cutter
	Insufficient tightening of the mounting bolts of the bed knife base	Operating machine and mower units - Inspection and repair of each section - Bed knife
Cutting height adjustment gets out of order.	Malfunction of the roller bearing	Operating machine and mower units - Inspection and repair of each section - Roller Replacement of the bearing
	Looseness of the cutting height adjustment nuts	This mower unit's Owner's Operating Manual
	Abrasion of the roller shaft	Operating machine and mower units - Inspection and repair of each section - Roller Replacement of the roller shaft
Mowed face is not flat	The cutting heights of the mower units are not consistent	This mower unit's Owner's Operating Manual
	The edge is rounded	Operating machine and mower units - Inspection and repair of each section - Grinding
	The operating speed is too fast.	Operate at an appropriate speed.
Mower units moves irregularly	Malfunction of the roller part	Operating machine and mower units - Inspection and repair of each section - Roller
	The operating speed is too fast.	Operate at an appropriate speed.
	Insufficient tension in unit damper spring	This mower unit's Owner's Operating Manual
The groomer does not rotate	The groomer clutch lever is OFF	Turn the groomer clutch lever ON
	Malfunction inside the groomer gear case	Removal and installation of each part - Inspection of the groomer Replacement of the groomer gear case
The CR brush does not rotate	Insufficient drive belt tension, or severed	Removal and installation of each section - Adjustment - CR brush assy Replacement of the drive belt
	The brush contacts the roller with too strong pressure	Removal and installation of each section - Adjustment - CR brush assy
	Faulty CR brush	Removal and installation of each section - Adjustment - CR brush assy Replacement of the CR brush assy

# Troubleshooting

Problem	Cause	Reference
The CR brush does not rotate	Malfunction of bearing	Removal and installation of each section - Adjustment - CR brush assy Replacement of the CR brush assy
Clippings do not enter the grass catcher smoothly	Insufficient adjustment of the reel cover	This mower unit's Owner's Operating Manual
	Insufficient rotation of the reel cutter	This mower unit's Owner's Operating Manual
	Wrong installation of the grass catcher	This mower unit's Owner's Operating Manual

# Troubleshooting

---

**Specifications list ..... Page 6-2**

LH62 ..... Page 6-2

LH66 ..... Page 6-3

**Maintenance Schedule ..... Page 6-4**



# Reference

## Specifications list

### LH62

Model		LH62			
Type		Base unit (incl. two weights)		With groomer	
Dimensions	Total length	17.76 in	451 mm	17.76 in	451 mm
	Total width	30.35 in	771 mm	30.35 in	771 mm
	Total height	11.50 in	292 mm	11.50 in	292 mm
Weight	Mower Unit	123.46 lb	56.0 kg	134.48 lb	61.0 kg
	Weight (one piece)	4.41 lb	2.0 kg	—	—
	Groomer	—	—	19.84 lb	9.0 kg
	CR brush	—	—	—	—
	Groomer + CR brush	—	—	—	—
Operating height (Mowing height)		0.315 - 1.772 in	8.0 - 45.0 mm	0.315 - 1.772 in	8.0 - 45.0 mm
Operating width (Mowing width)		22 in	557.5 mm	22 in	557.5 mm
Diameter of the reel cutter		6.4 in	163 mm	6.4 in	163 mm
Blades		9		9	

Model		LH62			
Type		With CR brush type A		With groomer and CR brush type B	
Dimensions	Total length	18.70 in	475 mm	18.70 in	475 mm
	Total width	30.16 in [30.87 in]	766 mm [784 mm]	30.87 in	784 mm
	Total height	11.50 in	292 mm	11.50 in	292 mm
Weight	Mower Unit	125.66 lb [127.87 lb]	57.0 kg [58.0 kg]	143.30 lb	65.0 kg
	Weight (one piece)	—	—	—	—
	Groomer	—	—	—	—
	CR brush	11.02 lb [13.23 lb]	5.0 kg [6.0 kg]	—	—
	Groomer + CR brush	—	—	28.66 lb	13.0 kg
Operating height (Mowing height)		0.315 - 1.772 in	8.0 - 45.0 mm	0.315 - 1.772 in	8.0 - 45.0 mm
Operating width (Mowing width)		22 in	557.5 mm	22 in	557.5 mm
Diameter of the reel cutter		6.4 in	163 mm	6.4 in	163 mm
Blades		9		9	

The values in the brackets [ ] are for CR brush type B.

## LH66

Model		LH66			
Type		Base unit (incl. two weights)		With groomer	
Dimensions	Total length	17.76 in	451 mm	17.76 in	451 mm
	Total width	34.41 in	874 mm	34.37 in	873 mm
	Total height	11.50 in	292 mm	11.50 in	292 mm
Weight	Mower Unit	134.48 lb	61.0 kg	145.50 lb	66.0 kg
	Weight (one piece)	4.41 lb	2.0 kg	—	—
	Groomer	—	—	19.84 lb	9.0 kg
	CR brush	—	—	—	—
	Groomer + CR brush	—	—	—	—
Operating height (Mowing height)		0.315 - 1.772 in	8.0 - 45.0 mm	0.315 - 1.772 in	8.0 - 45.0 mm
Operating width (Mowing width)		26 in	660 mm	26 in	660 mm
Diameter of the reel cutter		6.4 in	163 mm	6.4 in	163 mm
Blades		7 • 9		7 • 9	

Model		LH66			
Type		With CR brush type A		With groomer and CR brush type B	
Dimensions	Total length	18.66 in	474 mm	18.66 in	474 mm
	Total width	34.17 in [34.92 in]	868 mm [887 mm]	34.92 in	887 mm
	Total height	11.50 in	292 mm	11.50 in	292 mm
Weight	Mower Unit	136.68 lb [138.89 lb]	62.0 kg [63.0 kg]	154.32 lb	70.0 kg
	Weight (one piece)	—	—	—	—
	Groomer	—	—	—	—
	CR brush	11.02 lb [13.23 lb]	5.0 kg [6.0 kg]	—	—
	Groomer + CR brush	—	—	28.66 lb	13.0 kg
Operating height (Mowing height)		0.315 - 1.772 in	8.0 - 45.0 mm	0.315 - 1.772 in	8.0 - 45.0 mm
Operating width (Mowing width)		26 in	660 mm	26 in	660 mm
Diameter of the reel cutter		6.4 in	163 mm	6.4 in	163 mm
Blades		7 • 9		7 • 9	

The values in the brackets [ ] are for CR brush type B.

# Reference

## Maintenance Schedule

LH62 • LH66

Follow the maintenance schedule below.

○ • • • Inspect, adjust, supply, clean

● • • • Replace (first time)

△ • • • Replace

Maintenance Item	Before Work	After Work	Every 10 hrs.	Every 50 hrs.	Every 250 hrs.	Every 500 hrs.	When Required	Remarks
Check blade condition (Reel cutter and Bed knife)	○							Refer to "Inspection of Reel Cutter (Cutting Cylinder) and Bed Knife (Bottom Blade)"
Check cover condition	○							Refer to "Inspection of Covers"
Check roller condition	○							Refer to "Inspection of Roller"
Check groomer condition	○							Refer to "Inspection of Groomer"
Check CR brush condition	○							Refer to "Inspection of CR Brush"
Check scraper condition	○							Refer to "Inspection of Scraper"
Check belt condition	○							Refer to "Inspection of Belt"
Check damaged parts	○							
Check tightening bolts and nuts	○							
Engage blades	○							Refer to "Adjustment of Blade Engagement"
Check mowing height	○							Refer to "Adjustment of Cutting Height"
Adjust reel cover (Variable type)	○							Refer to "Adjustment of Reel Cover (Variable Type)"
Adjust groomer	○							Refer to "Adjustment of Groomer"
Adjust CR brush	○							Refer to "Adjustment of CR Brush"
Adjust scraper	○							Refer to "Adjustment of Scraper"
Clean mower unit		○						Refer to "Cleaning of Mower Unit"
Backlap blades							○	Refer to "Back Lapping of Reel Cutter (Cutting Cylinder)"
Grease groomer gears in the case			○					Refer to "Greasing Points"
Grease				○				Refer to "Greasing Points"
Clean inside of CR brush belt cover				○				
Grease hydraulic motor shaft of mower unit					○			
Grease spindle bolt of reel housing						○		

## Reference

Maintenance Item	Before Work	After Work	Every 10 hrs.	Every 50 hrs.	Every 250 hrs.	Every 500 hrs.	When Required	Remarks
Adjust cutter adjustment spring							<input type="radio"/>	Refer to "Adjustment of Cutter Adjustment Spring"
Adjust belt tension of CR brush							<input type="radio"/>	Refer to "CR Brush Drive Belt"
Regrind blades (Reel cutter and Bed knife)							<input type="radio"/>	Regrind/Replace blades as and when required

- The values for consumables are not guaranteed.

# Reference

---

**BARONESS**<sup>®</sup>  
Quality on Demand

 **KYOEISHA CO., LTD.**  
Head Office 1-26, Miyuki-cho, Toyokawa, Tel : (0533) 84-1390  
Aichi-Pref. 442-8530 Japan. Fax : (0533) 89-3623