

LS62 · LS66

Standard Mower Unit

Service Manual

Serial No. LS62 : 10001- · LS66 : 10001-

BARONESS[®]
Quality on Demand

Ver.1.0

Introduction

This document outlines maintenance procedures, fault diagnosis and other details for the mower unit.

Details have been categorized systematically in accordance with the main types of maintenance.

For repairs, please contact your sales dealer or Kyoeshia.

For information on operation, handling and maintenance instructions, please refer to the Owner's Operating Manual.

Refer to the Parts Catalog for required parts.

Kyoeshia Co., Ltd.

Caution

The details included in this document are subject to notice due to improvements.

When replacing parts, always use genuine Baroness parts or parts specified by Kyoeshia.

Note that no responsibility will be taken for defects caused by use of non-genuine parts.





List of Suitable Baroness Machine

The Baroness main body models that can be equipped with the STD mower unit are listed below.

	LS62	LS66	Remarks
	22 in.	26 in.	
LM331	-	○	
LM551	○	○	
LM551A	○	○	

Warning Symbols

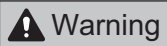
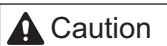
This manual uses the following warning symbols for handling precautions that are important for your safety.

 <p>696cq5-001</p>	<p>Warning symbol</p>
<p>This symbol indicates the articles regarding “Danger,” “Warning,” or “Caution.” Those articles describe important safety precautions and so read them carefully to understand completely before operating the machine. Failure to adequately follow these safety precautions may cause an accident.</p>	
<p> Danger</p> <p>This symbol indicates that serious injury or death will occur if the warning is ignored.</p> <p> Warning</p> <p>This symbol indicates that serious injury or death may occur if the warning is ignored.</p> <p> Caution</p> <p>This symbol indicates that injury or damage to property may occur if the warning is ignored.</p> <p> Important</p> <p>This symbol indicates precautions on the mechanism of the machine.</p>	

Introduction

Safety	Page 1-1
Safety Precautions	Page 1-2
Safety Signs and Instruction Signs	Page 1-2
Disposal	Page 2-1
Recycle and Waste Disposal	Page 2-2
Maintenance standards and maintenance ...	Page 3-1
Unit conversion	Page 3-2
Maintenance standards	Page 3-4
Tightening torques	Page 3-5
General precautions	Page 3-7
Greasing	Page 3-9
Operating Machine and Mower Units	Page 4-1
Maintenance	Page 4-2
Special Tool	Page 4-2
Adjustment	Page 4-7
Removal and installation of each section	Page 4-13
Inspection and repair of each section	Page 4-30
Troubleshooting	Page 5-1
Relating to Operating Machine and Mower Unit	Page 5-2
Reference	Page 6-1
Specifications list	Page 6-2
Maintenance Schedule	Page 6-3

Contents

Safety Precautions Page 1-2

Safety Signs and Instruction Signs Page 1-2

About Safety Decals and Instruction
DecalsPage 1-2

Safety

Failure to adequately follow these safety precautions may cause an accident resulting in injury or death.

Danger

This mower unit is designed to ensure safe operation and has been tested and inspected thoroughly before shipment from the factory. The machine is equipped with safety devices to prevent accidents.

However, whether the machine demonstrates its original performance level depends on the manner in which it is operated and handled, as well as the manner in which it is managed on a daily basis.

Inappropriate use or management of the machine may result in injury or death.

Observe the following safety instructions to ensure safe operation.

Safety Precautions

Read Safe Operating Practices described in the Owner's Operating Manual of Baroness main vehicle equipped with this mower unit thoroughly.

Safety Signs and Instruction Signs

About Safety Decals and Instruction Decals

Warning

Safety decals and instruction decals are attached to this mower unit.

Make sure that decals are preserved in their entirety. If they are damaged, become dirty, or peel off, replace them with new ones.

Part numbers for decals that need to be replaced are listed in the parts catalog. Order them from a Baroness dealer or Kyo-eisha.

Recycle and Waste Disposal Page 2-2

About RecyclePage 2-2

About the Waste disposal Page 2-2

Disposal

Recycle and Waste Disposal

About Recycle

Recycling battery etc. is recommended for environmental conservation and economical use of resources.

It may be required by local laws.

About the Waste disposal

Make sure that waste generated when servicing or repairing the machine is disposed of in accordance with local regulations. (e.g. waste oil, antifreeze, rubber products, and wires etc.)

Maintenance standards and maintenance

Unit conversionPage 3-2

Inch-millimeter conversion table Page 3-2

US unit-SI unit conversion tablePage 3-3

Maintenance standardsPage 3-4

List of Maintenance Specifications Page 3-4

Tightening torques Page 3-5

Standard tightening torques Page 3-5

Principal tightening torques Page 3-6

General precautions Page 3-7

Bearing Page 3-7

Stop Ring Page 3-8

Greasing Page 3-9

About GreasingPage 3-9

Greasing Points Page 3-9

Maintenance standards and maintenance

Unit conversion

Inch-millimeter conversion table

1 mm = 0.03937 in

1 in = 25.4 mm

Fractions		Decimals	mm	Fractions		Decimals	mm
	1/64	0.015625	0.397		33/64	0.515625	13.097
	1/32	0.03125	0.794		17/32	0.53125	13.494
	3/64	0.046875	1.191		35/64	0.546875	13.891
1/16		0.0625	1.588	9/16		0.5625	14.288
	5/64	0.078125	1.984		37/64	0.578125	14.684
	3/32	0.09375	2.381		19/32	0.59375	15.081
	7/64	0.109275	2.778		39/64	0.609375	15.478
1/8		0.1250	3.175	5/8		0.6250	15.875
	9/64	0.140625	3.572		41/64	0.640625	16.272
	5/32	0.15625	3.969		21/32	0.65625	16.669
	11/64	0.171875	4.366		43/64	0.671875	17.066
3/16		0.1875	4.762	11/16		0.6875	17.462
	13/64	0.203125	5.159		45/64	0.703125	17.859
	7/32	0.21875	5.556		23/32	0.71875	18.256
	15/64	0.234375	5.953		47/64	0.734375	18.653
1/4		0.2500	6.350	3/4		0.7500	19.050
	17/64	0.265625	6.747		49/64	0.765625	19.447
	9/32	0.28125	7.144		25/32	0.78125	19.844
	19/64	0.296875	7.541		51/64	0.796875	20.241
5/16		0.3125	7.938	13/16		0.8125	20.638
	21/64	0.328125	8.334		53/64	0.828125	21.034
	11/32	0.34375	8.731		27/32	0.84375	21.431
	23/64	0.359375	9.128		55/64	0.859375	21.828
3/8		0.3750	9.525	7/8		0.8750	22.225
	25/64	0.390625	9.922		57/64	0.890625	22.622
	13/32	0.40625	10.319		29/32	0.90625	23.019
	27/64	0.421875	10.716		59/64	0.921875	23.416
7/16		0.4375	11.112	15/16		0.9375	23.812
	29/64	0.453125	11.509		61/64	0.953125	24.209
	15/32	0.46875	11.906		31/32	0.96875	24.606
	31/64	0.484375	12.303		63/64	0.984375	25.003
1/2		0.5000	12.700	1		1.000	25.400

Maintenance standards and maintenance

US unit-SI unit conversion table

To Convert			Into		Multiply By
Linear Measurement	Miles	mi	Kilometers	km	1.609
	Yards	yd	Meters	m	0.9144
	Feet	ft	Meters	m	0.3048
	Feet	ft	Centimeters	cm	30.48
	Inches	in	Meters	m	0.0254
	Inches	in	Centimeters	cm	2.54
	Inches	in	Millimeters	mm	25.4
Area	Square Miles	mile ²	Square Kilometers	km ²	2.59
	Square Feet	ft ²	Square Meters	m ²	0.0929
	Square Inches	in ²	Square Centimeters	cm ²	6.452
	Acre	ac	Hectare	ha	0.4047
Volume	Cubic Yards	yd ³	Cubic Meters	m ³	0.7646
	Cubic Feet	ft ³	Cubic Meters	m ³	0.02832
	Cubic Inches	in ³	Cubic Centimeters	cm ³	16.39
Weight	Tons (Short)	sh tn	Metric Tons	ton	0.9078
	Pounds	lb	Kilograms	kg	0.4536
	Ounces (Avdp.)	oz	Grams	g	28.3495
Pressure	Pounds/Sq. In.	psi	Kilopascal	kPa	6.895
	Pounds/Sq. In.	psi	Bar	mdyn/cm ²	0.069
Work	Foot-pounds	lb-ft	Newton-Meters	N-m	1.356
	Foot-pounds	lb-ft	Kilogram-Meters	kgf-m	0.1383
	Inch-pounds	lb-in	Kilogram-Centimeters	kgf-cm	1.152144
Liquid Volume	Quarts	qt (US)	Liters	L	0.9463
	Gallons	gal (US)	Liters	L	3.785
Liquid Flow	Gallons/Minute	gal/min	Liters/Minute	L/min	3.785
Temperature	Fahrenheit	°F	Celsius	°C	1. Subtract 32 ° 2. Multiply by 5/9

Maintenance standards and maintenance

Maintenance standards

List of Maintenance Specifications

Item	Adjusted Value		Remarks
	LS62	LS66	
Cutter adjustment spring	40.0 mm (1.575 in)	←	Spring coil length
Front roller spring	1.0 - 3.0 mm (0.039 - 0.118 in)	←	Front roller spring clearance
Front roller assy	593.5 mm (23.36 in)	696.0 mm (27.40 in)	Front roller assy total length
CR brush drive belt	5.0 - 6.0 mm (0.197 - 0.236 in)	←	Slack with 10.0 N (1.0 kgf) force applied around center section between belt pulleys
CR brush	0 - 1.0 mm (0 - 0.039 in)	←	Brush and rear roller clearance
Front scraper	2.0 - 3.0 mm (0.079 - 0.118 in)	←	Scraper and roller outer diameter surface clearance
Rear scraper	2.0 - 3.0 mm (0.079 - 0.118 in)	←	Scraper and roller clearance
Reel cutter usage limit (outer dimensions)	143.0 mm (56.30 in)	←	Replace if below standard values

Maintenance standards and maintenance

Tightening torques

Standard tightening torques

Bolts and Nuts

Important

A number of bolts are used in each part of this machine.
Be sure to re-tighten the bolts and nuts, because they may be loosened at the earlier stage of the use.

As to the bolts and nuts without any special instruction, tighten them in appropriate tightening torque with proper tool.

Too much tightening may cause the looseness or damage of the screw.

The strength of tightening is determined by types of screws, strength, the friction of thread face or base face and others.

The table below is for the galvanized or parkerized bolts.

In case that the strength of internal thread is weak, it is not applied.

Do not use rusty or sand attached "screw."

Otherwise, it may cause insufficient tightening even if you apply the specified tightening torque.

The friction of the screw face becomes higher and the tightening torque is canceled out by the friction, therefore sufficient tightening cannot be applied.

If "screw" is wet by water or oil, do not tighten it with normal tightening torque.

If the screw is wet, the torque coefficient will get smaller and it may result in too much tightening.

Too much tightening may cause looseness by the screw stretched or result in damage.

Do not use a bolt experienced too much burden.

Using the impact wrench requires the skill.

Do exercise as much as possible for steady tightening.

Nominal diameter	General bolt		
	Strength classification 4.8		
			
	N-m	kgf-cm	lb-in
M5	3 - 5	30.59 - 50.99	26.55 - 44.26
M6	7 - 9	71.38 - 91.77	61.96 - 79.66
M8	14 - 19	142.76 - 193.74	123.91 - 168.17
M10	29 - 38	295.71 - 387.49	256.68 - 336.34
M12	52 - 67	530.24 - 683.20	460.25 - 593.02
M14	70 - 94	713.79 - 958.52	619.57 - 831.99
M16	88 - 112	897.34 - 1142.06	778.89 - 991.31
M18	116 - 144	1,182.85 - 1,468.37	1,026.72 - 1,274.54
M20	147 - 183	1,498.96 - 1,866.05	1,301.10 - 1,619.73
M22	295	3,008.12	2,611.05
M24	370	3,772.89	3,274.87
M27	550	5,608.35	4,868.05
M30	740	7,545.78	6,549.74

Maintenance standards and maintenance

Nominal diameter	Heat-treated bolt					
	Strength classification 8.8			Strength classification 10.9		
	N-m	kgf-cm	lb-in	N-m	kgf-cm	lb-in
M5	5 - 7	50.99 - 71.38	44.26 - 61.96	7 - 10	71.38 - 101.97	61.96 - 88.51
M6	8 - 11	81.58 - 112.17	70.81 - 97.36	14 - 18	142.76 - 183.55	123.91 - 159.32
M8	23 - 29	234.53 - 295.71	203.57 - 256.68	28 - 38	285.52 - 387.49	247.83 - 336.34
M10	45 - 57	458.87 - 581.23	398.30 - 504.51	58 - 76	591.43 - 774.97	513.36 - 672.68
M12	67 - 85	683.20 - 866.75	593.02 - 752.34	104 - 134	1,060.49 - 1,366.40	920.50 - 1186.03
M14	106 - 134	1,080.88 - 1,366.40	938.21 - 1,186.03	140 - 188	1,427.58 - 1,917.04	1,239.14 - 1,663.99
M16	152 - 188	1,549.94 - 1,917.04	1,345.35 - 1,663.99	210 - 260	2,141.37 - 2,651.22	1,858.71 - 2,301.26
M18	200 - 240	2,039.40 - 2,447.28	1,770.20 - 2,124.24	280 - 340	2,855.16 - 3,466.98	2,478.28 - 3,009.34
M20	245 - 295	2,498.27 - 3,008.12	2,168.50 - 2,611.05	370 - 450	3,772.89 - 4,588.65	3,274.87 - 3,982.95
M22	-	-	-	530	5,404.41	4,691.03
M24	-	-	-	670	6,831.99	5,930.17
M27	-	-	-	1,000	10,197.00	8,851.00
M30	-	-	-	1,340	14,628.78	11,860.34

Note:
The same values are applied to "fine screw thread."

Principal tightening torques

Tightening Torque by Model

LH66/LH62
LS66/LS62

Tighten the following bolts and nuts at the torque specified in the table.

For thread locking adhesive, apply a middle strength thread locker (ThreeBond 1322 or equivalent anaerobic sealant).

Location	Code	Part name	Tightening torque			Thread locking adhesive
			N-m	kgf-cm	lb-in	
Bed knife	K0071000092	SCREW, HT FLAT HEAD M10-20	29 - 38	295.71 - 387.49	256.68 - 336.34	-

Maintenance standards and maintenance

General precautions

Bearing

The bearing is a precision machine part. Install the bearing in an appropriate work environment so that dust does not enter the interior, and be extremely careful not to subject the bearing to strong impact. To install the bearing correctly, use a bearing driver.

⚠ Caution

Be careful not to hit your hand with a hammer etc.

1. When pressing the bearing into the shaft, apply pressure evenly around the inner ring of the bearing using the bearing driver.

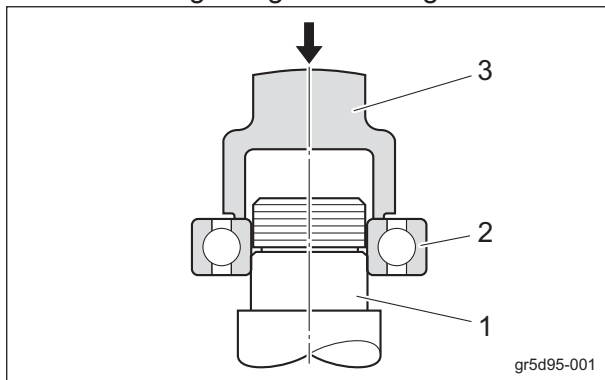

Bearing_001

1	Shaft
2	Bearing
3	Bearing driver

2. When pressing the bearing into the housing, apply pressure evenly around the outer ring of the bearing using the bearing driver.

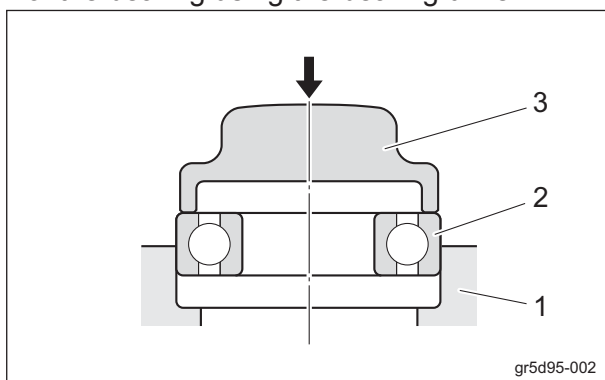

Bearing_002

1	Housing
2	Bearing
3	Bearing driver

3. When pressing the bearing into the shaft and housing evenly, apply pressure evenly with the bearing driver in contact with the inner ring and outer ring of the bearing.

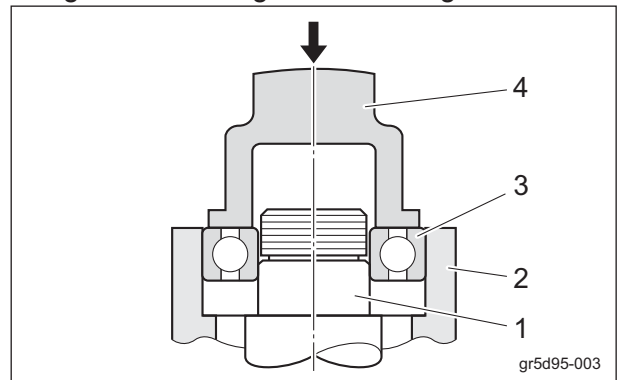

Bearing_003

1	Shaft
2	Housing
3	Bearing
4	Bearing driver

Maintenance standards and maintenance

Stop Ring

⚠ Caution

When attaching the stop ring to a hole or a shaft, the stop ring may become disengaged from the dedicated pliers, fly off, and cause injury. Take extra precautions to ensure that the stop ring does not become disengaged from the pliers.

⚠ Caution

When attaching the stop ring to a hole or a shaft, do not contract or expand the stop ring more than necessary. Excessive contraction or expansion of the stop ring may cause increased deformation, which may lead to play and disengagement from the groove.

1. There are two types of stop rings: one for a hole and one for a shaft. Both stop rings have a front and a back. The front side is rounded, and the back side has a sharp edge.

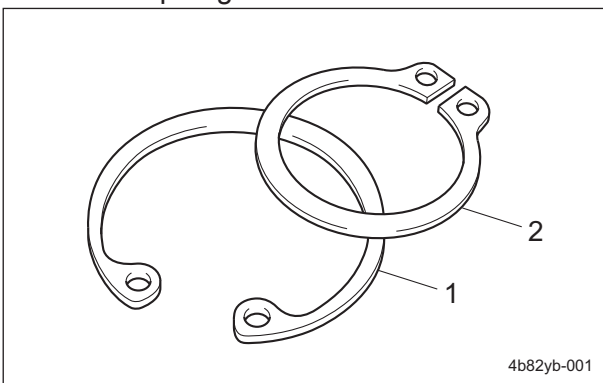

Stop Ring_001

1	Stop ring for hole
2	Stop ring for shaft

2. When attaching the stop ring for a shaft, assemble the stop ring so that the sharp edge side receives the load (indicated by an arrow).

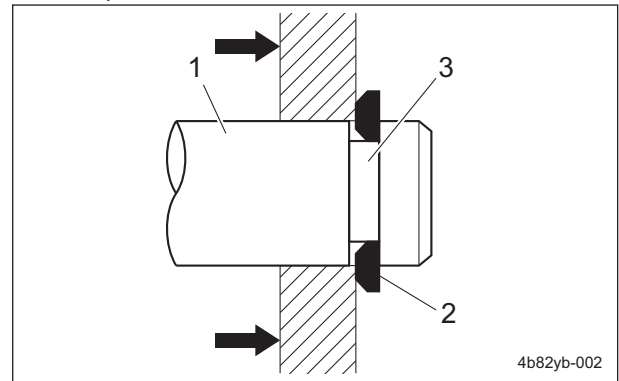

Stop Ring_002

1	Shaft
2	Stop ring (sharp edge side)
3	Stop ring groove

3. When attaching the stop ring for a hole, assemble the stop ring so that the sharp edge side receives the load (indicated by an arrow).

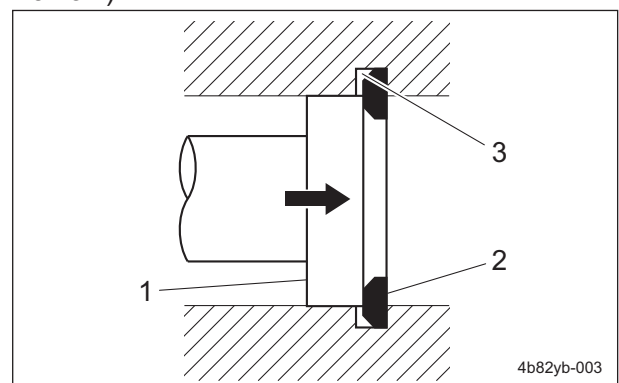

Stop Ring_003

1	Shaft
2	Stop ring (sharp edge side)
3	Stop ring groove

Maintenance standards and maintenance

Greasing

About Greasing

Since there may be adhesion or damage due to lack of grease on moving parts, they must be greased.

Add urea-based No. 2 grease in accordance with the Maintenance Schedule.

Other locations where the specified grease or lubricant is used are indicated in "Greasing Points".

Add grease using the specified grease or lubricant.

Greasing Points

Grease nipples are installed in the following locations.

Add grease every 50 hours of operation.

However, for locations where a time is specified, add grease according to that schedule.

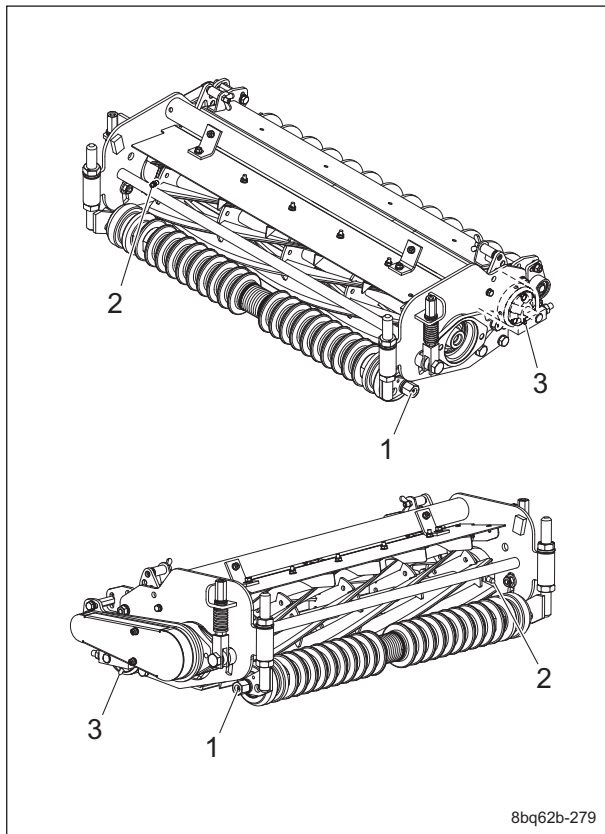

Greasing Points_001

8bq62b-279

	Location	No. of greasing points
1	Front roller shaft	2
2	Housing	2
3	Rear roller shaft	2

1. Front roller shaft

There is one point each on the left and right of the front roller shaft.

Left end of front roller

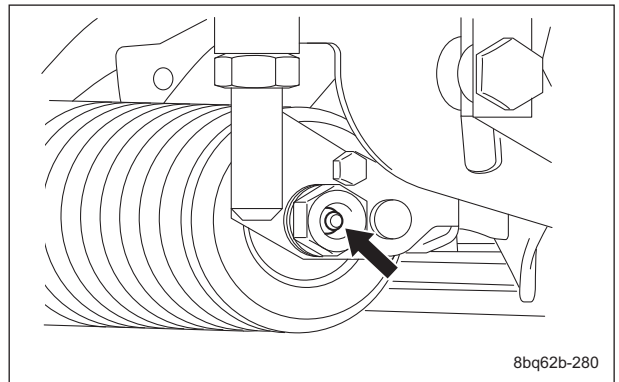

8bq62b-280

Greasing Points_002

Right end of front roller

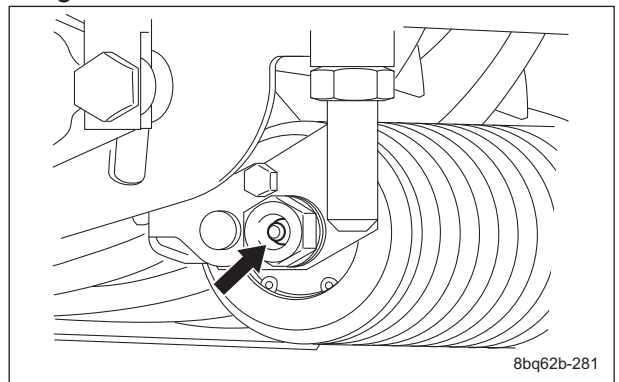

8bq62b-281

Greasing Points_003

2. Housing

There is one point each on the left and right of the housing.

Hydraulic motor housing side

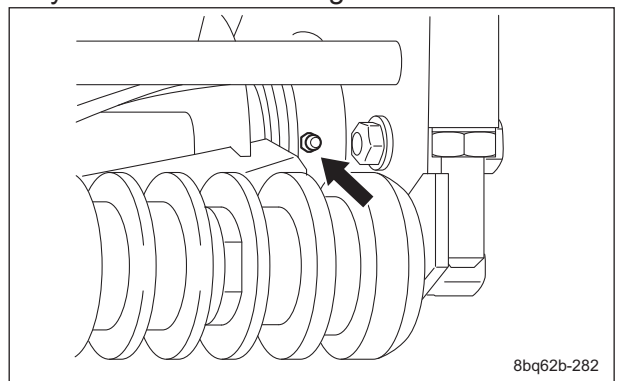

8bq62b-282

Greasing Points_004

Maintenance standards and maintenance

Reel housing side

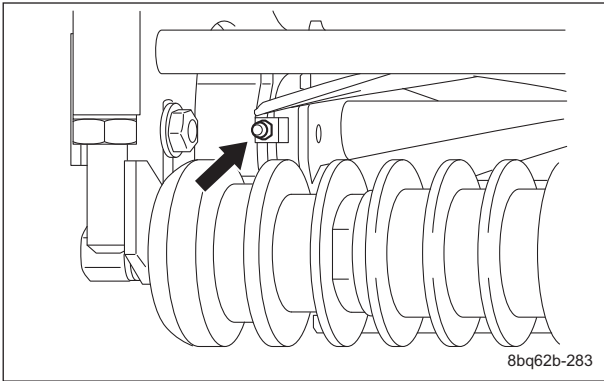

Greasing Points_005

3. Rear roller shaft

There is one point each on the left and right of the rear roller shaft.

Left end of rear roller

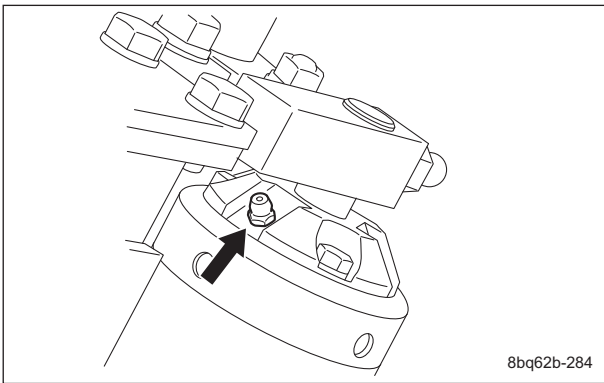

Greasing Points_006

Right end of rear roller

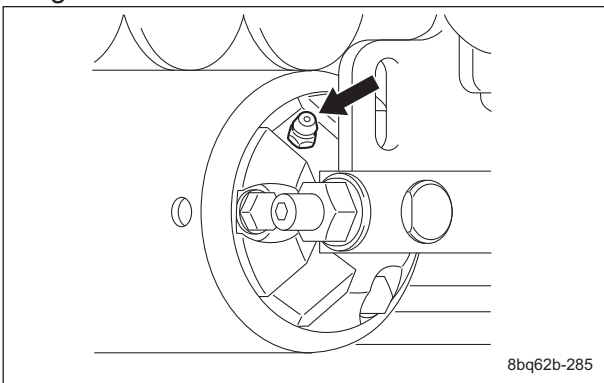

Greasing Points_007

Operating Machine and Mower Units

Maintenance Page 4-2

About MaintenancePage 4-2

Special ToolPage 4-2

List of Special ToolsPage 4-2

Adjustment Page 4-7

Adjustment of Blade Engagement Page 4-7

Adjustment of Cutting Height Page 4-8

Adjustment of Cutter Adjustment
Spring Page 4-9

Adjustment of Reel Cover (Variable
Type)Page 4-9

Adjustment of Reel Cover (Variable
Easy Latch Type)Page 4-9

Adjustment of CR brush Page 4-10

Adjustment of Scraper Page 4-11

Adjustment of Belt TensionPage 4-12

Removal and installation of each section Page 4-13

Reel coverPage 4-13

Bed Knife Mounting Assy Page 4-16

Bed knifePage 4-18

Reel CutterPage 4-19

Front Roller Assy Page 4-25

Rear Roller AssyPage 4-26

CR Brush Assy Page 4-28

Inspection and repair of each section Page 4-30

Reel CoverPage 4-30

Reel cutter Page 4-30

Reel Housing Page 4-36

Hydraulic Motor Housing Page 4-38

Bed knifePage 4-39

Roller Page 4-40

CR Brush Assy Page 4-45

Operating Machine and Mower Units

Maintenance

About Maintenance

This chapter describes primary checking and maintenance operations for the STD mower unit.

For information on daily checks, maintenance and handling of the mower unit, please refer to the separate STD Mower Unit's Owner's Operating Manual and Parts Catalog.

For information on attaching and removing optional parts and attachments, please refer to the handling manual for the corresponding attachment.

Special Tool

List of Special Tools

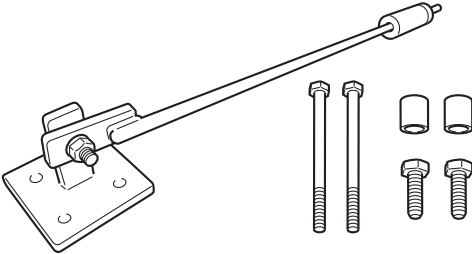
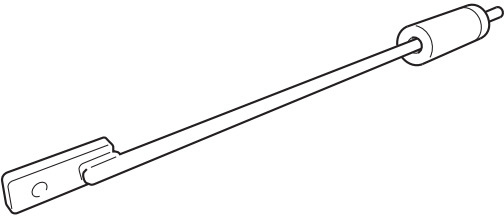
<p>Sliding hammer 318</p>  <p>q9c6v6-023</p>	<p>K4802000460</p>	<p>Used when removing the reel housing and other parts.</p>
<p>Sliding hammer</p>  <p>q9c6v6-024</p>	<p>K480200047D</p>	<p>One of the parts that compose the sliding hammer 318 and used together with the mounting bracket.</p>

Operating Machine and Mower Units

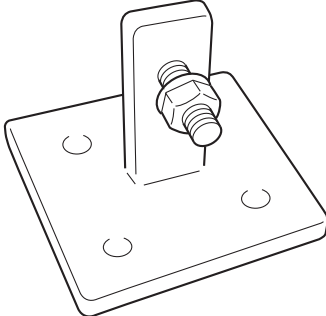
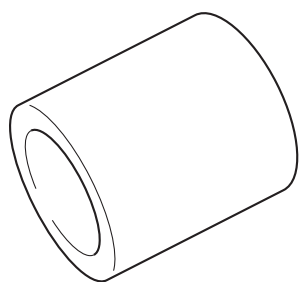
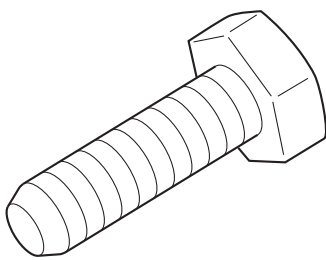
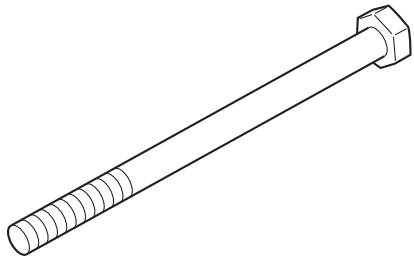
<p>Mounting bracket</p>  <p style="text-align: right;">q9c6v6-025</p>	<p>K480200048D</p>	<p>One of the parts that compose the sliding hammer 318 and used by being mounted on the gear motor and housing.</p>
<p>12.7 collar 17.320.2</p>  <p style="text-align: right;">q9c6v6-026</p>	<p>K6211000012</p>	<p>One of the parts that compose the sliding hammer 318 and used between the gear motor and mounting bracket.</p>
<p>Bolt, M10-30</p>  <p style="text-align: right;">q9c6v6-027</p>	<p>K0000100302</p>	<p>One of the parts that compose the sliding hammer 318 and used to remove the housing, etc.</p>
<p>Bolt, M12-140</p>  <p style="text-align: right;">q9c6v6-028</p>	<p>K0003121402</p>	<p>One of the parts that compose the sliding hammer 318 and used to remove the gear motor.</p>

Operating Machine and Mower Units

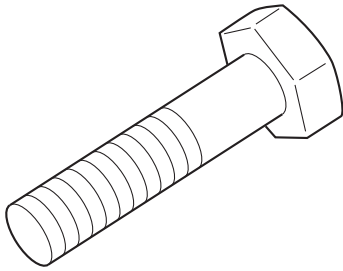
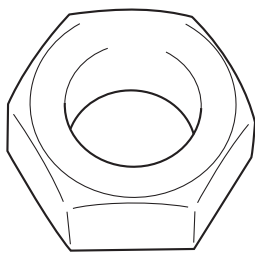
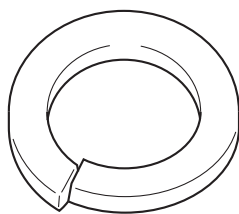
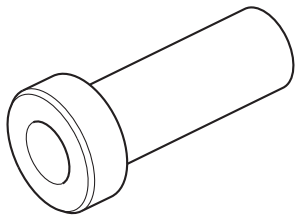

Operating Machine and Mower Units

<p>Bolt, heat-treated M14-50</p>  <p>q9c6v6-029</p>	<p>K0013140502</p>	<p>One of the parts that compose the sliding hammer 318 and used to fix the sliding hammer and mounting bracket.</p>
<p>14 Nut</p>  <p>q9c6v6-030</p>	<p>K0100140002</p>	<p>One of the parts that compose the sliding hammer 318 and used to fix the sliding hammer and mounting bracket.</p>
<p>Spring washer 14</p>  <p>q9c6v6-031</p>	<p>K0200140002</p>	<p>One of the parts that compose the sliding hammer 318 and used to fix the sliding hammer and mounting bracket.</p>
<p>6207 Bearing driver</p>  <p>q9c6v6-009</p>	<p>K4802000492</p>	<p>Used when installing bearings with outer $\varnothing 72$ and inner $\varnothing 35$.</p>

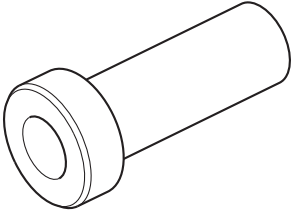
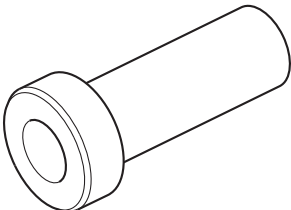
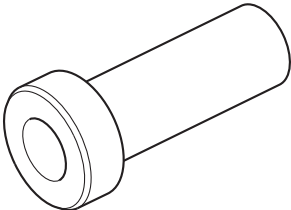
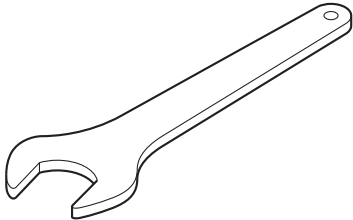
Operating Machine and Mower Units

<p>6005 Bearing driver</p>  <p>q9c6v6-009</p>	<p>K4802000502</p>	<p>Used when installing bearings with outer $\phi 47$ and inner $\phi 25$.</p>
<p>6303 Bearing driver</p>  <p>q9c6v6-009</p>	<p>K4802000752</p>	<p>Used when installing bearings with outer $\phi 47$ and inner $\phi 17$.</p>
<p>6003 Bearing driver</p>  <p>q9c6v6-009</p>	<p>K4802000842</p>	<p>Used when installing bearings with outer $\phi 35$ and inner $\phi 17$.</p>
<p>46 Single head wrench</p>  <p>q9c6v6-032</p>	<p>K480200081D</p>	<p>Used to disassemble or assemble the front roller.</p>

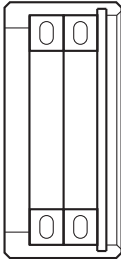
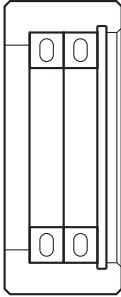
Operating Machine and Mower Units

<p>Holder assy φ52</p>  <p style="text-align: right;">q9c6v6-053</p>	<p>LM318--9103Z0</p>	<p>Used by the hydraulic motor side when setting the reel cutter in the grinding machine. Holder outer diameter φ52</p>
<p>Holder assy φ60</p>  <p style="text-align: right;">q9c6v6-054</p>	<p>LM318--9104Z0</p>	<p>Used by the hydraulic motor side when setting the reel cutter in the grinding machine. Holder outer diameter φ60</p>
<p>Holder assy φ60-20</p>  <p style="text-align: right;">q9c6v6-055</p>	<p>LM318--9115Z0</p>	<p>Used by the other side of the hydraulic motor when setting the reel cutter in the grinding machine. Holder outer diameter φ60</p>

Operating Machine and Mower Units

Adjustment

Adjustment of Blade Engagement

⚠ Danger

Make sure that the parking brake is firmly applied before performing the operation.

⚠ Caution

Be sure to perform this operation on your own.

⚠ Caution

When handling the reel cutter (cutting cylinder) or bed knife (bottom blade), wear gloves to protect your hands. However, pay attention not to let the reel cutter (cutting cylinder) catch your gloves, etc. Otherwise, you may injure your hand or fingers.

Important

If the CR brush is installed, loosen the left and right bolts and nuts used to install the CR brush before adjusting the blade engagement. After adjusting the blade engagement, adjust the CR brush, and then firmly tighten the loosened bolts and nuts.

1. Stop the engine.
2. Shift the reel rotation/stop switching lever to the "Stop" position.

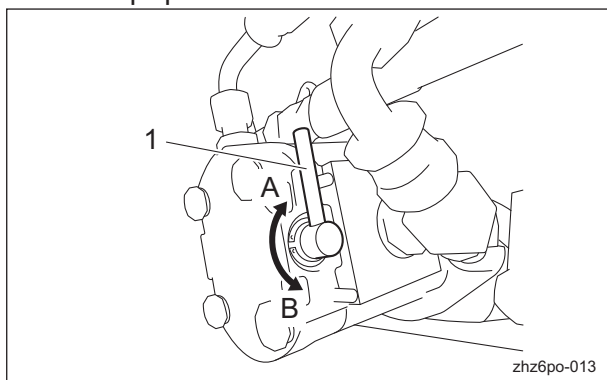

Adjustment of Blade Engagement_001

1	Reel rotation/stop switching lever
A	Rotation
B	Stop

3. With the cutter adjustment nut, adjust the engagement between the reel cutter (cutting cylinder) and the bed knife (bottom blade) so that newspaper (two to three sheets) will be cut by the edge of both blades when the blades in their entirety come slightly into contact with each other.

4. Insert two or three strips of newspaper into the space between the reel cutter (cutting cylinder) and the bed knife (bottom blade) at an angle of 90 degrees. Then, rotate the reel cutter (cutting cylinder) counterclockwise (as seen from the left side of the mower unit) by hand to check the sharpness.

Check the sharpness of the entire range (at three or four points between the left and right ends) of the reel cutter (cutting cylinder).

- If there is a gap between the blade edges: Loosen (rotate counter-clockwise) the cutter adjustment nut to apply more contact pressure between the reel cutter (cutting cylinder) and the bed knife (bottom blade).
- If the reel cutter (cutting cylinder) is too tight to turn: Tighten (rotate clockwise) the cutter adjustment nut to reduce the contact pressure between the reel cutter (cutting cylinder) and the bed knife (bottom blade).
- If the blades still cannot cut well: Perform back lapping of the reel cutter (cutting cylinder).

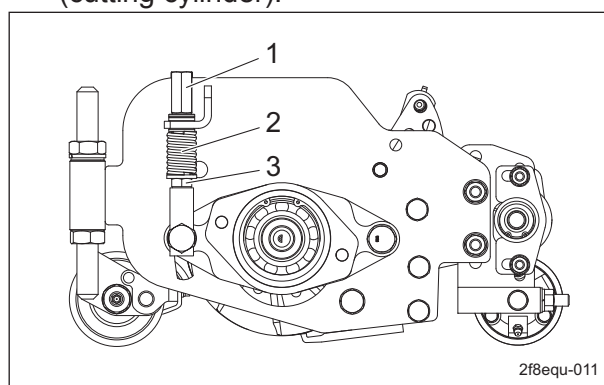

Adjustment of Blade Engagement_002

1	Cutter adjustment nut
2	Spring
3	Pipe with cutter adjustment screw

Operating Machine and Mower Units

Adjustment of Cutting Height

Cutting Height Adjustment

⚠ Caution

Do not perform the operation with any other persons.

Adjust the cutting height to fit your cutting work.
The rear roller can be adjusted to one of four settings.

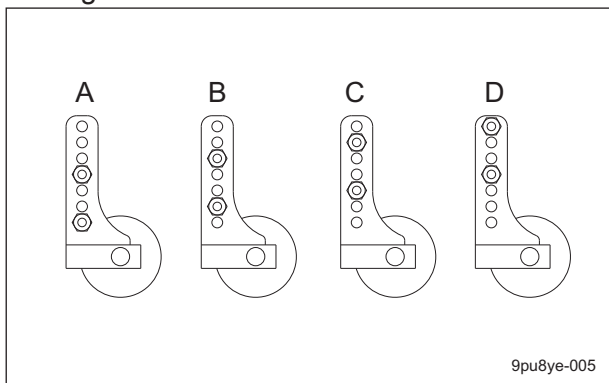

Cutting Height Adjustment_001

A	10 - 17 mm (0.39 - 0.67 in)
B	10 - 33 mm (0.39 - 1.30 in)
C	21 - 39 mm (0.83 - 1.54 in)
D	28 - 46 mm (1.10 - 1.81 in)

Note:

With the same cutting height for settings A and B, the clippings volume with B will be larger since the offset distance is longer. The same goes for settings B and C and settings C and D.

1. Attach the rear roller in a position that suits your work requirements within the cutting height range.
2. Set the slide caliper to the required cutting height, adjust the neck position of the cutting height screw of the cutting height gauge and securely lock with a fly nut.
3. Loosen the nut which fixes the roller bracket of the front roller.
4. Apply the cutting height gauge to the front and rear rollers at each edge of left and right of the mower unit.

5. Adjust the front roller up and down by the roller adjuster to determine the position of the front roller, in order not to have a gap with the neck position of the cutting height screw of the cutting height gauge, at the edge of the bed knife.

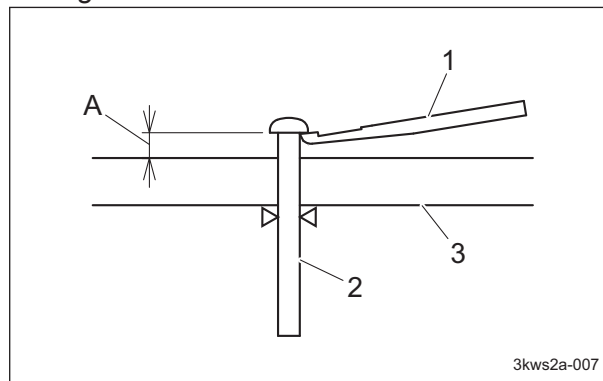

Cutting Height Adjustment_002

1	Bed knife (bottom blade)
2	Cutting height screw
3	Cutting height gauge
A	Cutting height

- To increase cutting height:
 - [1] Loosen cutting height adjustment nut A, tighten cutting height adjustment nut B, and then lower the front roller.
 - [2] Use the cutting height gauge to determine the cutting position, and then firmly tighten cutting height adjustment nut A.
- To decrease cutting height:
 - [1] Loosen cutting height adjustment nut B, tighten cutting height adjustment nut A, and then raise the front roller.
 - [2] Use the cutting height gauge to determine the cutting position, and then firmly tighten cutting height adjustment nut B.

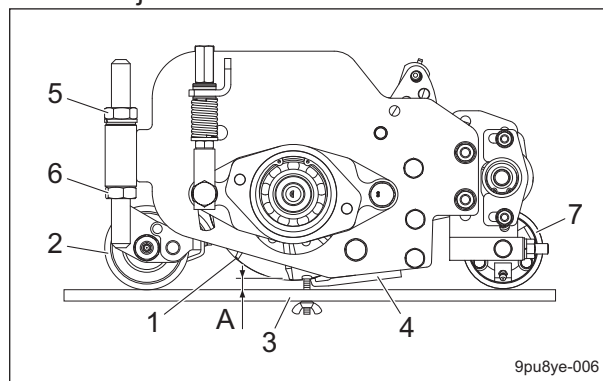

Cutting Height Adjustment_003

Operating Machine and Mower Units

1	Reel cutter (cutting cylinder)
2	Front roller
3	Cutting height gauge
4	Bed knife (bottom blade)
5	Cutting height adjustment nut A
6	Cutting height adjustment nut B
7	Rear roller
A	Cutting height

- Repeat the same process at the opposite side for the adjustment of cutting height.
- Again, make sure that the cutting height is at the required position by applying the cutting height gauge to the front and rear rollers at each edge of right and left of the mower unit.

Adjustment of Cutter Adjustment Spring

If the diameter of the reel cutter (cutting cylinder) becomes smaller, adjust the cutter adjustment spring.

- Adjust the blade engagement.
- Loosen the pipe with cutter adjusting screw, and then adjust the length of the spring coil to approximately 40 mm (1.575 in.).

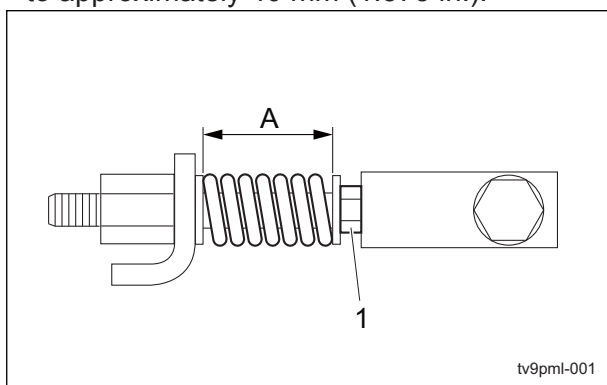

Adjustment of Cutter Adjustment Spring_001

1	Pipe with cutter adjusting screw
A	40 mm (1.575 in.)

Adjustment of Reel Cover (Variable Type)

Note:
Depending on the specifications, this function may not be available.
The angle of the reel cover can be adjusted.
The opening angle of the reel cover can be set to one of three positions in 15-degree increments.

- Pull the left and right knobs securing the reel cover in order to release it.

- Secure the reel cover to a different hole in the cover adjustment plate.

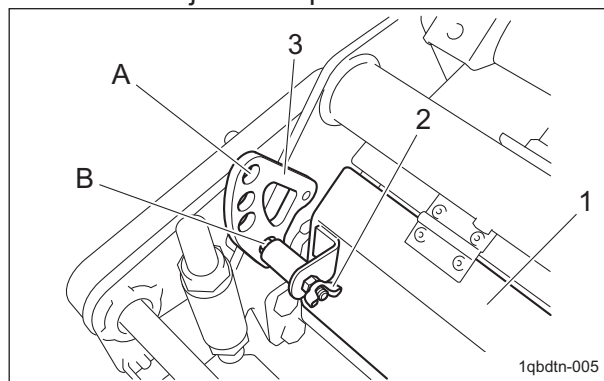

Adjustment of Reel Cover (Variable Type)_001

1	Reel cover
2	Knob
3	Cover adjustment plate
A	Fully open
B	Fully closed

Adjustment of Reel Cover (Variable Easy Latch Type)

Note:
Depending on the specifications, this function may not be available.
The angle of the reel cover can be adjusted.
The opening angle of the reel cover can be set to one of six positions in 12.5-degree increments.

- Pull the rod connecting the left and right knobs securing the reel cover in order to release the cover.

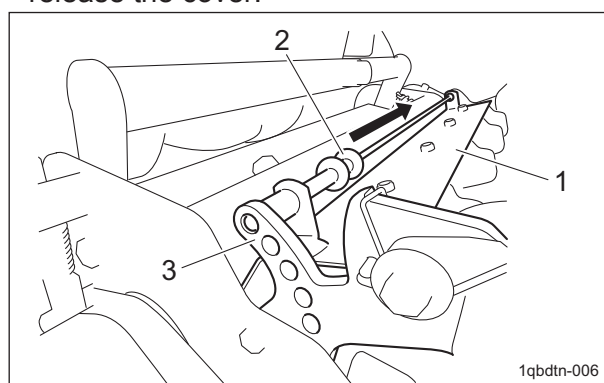

Adjustment of Reel Cover (Variable Easy Latch Type)_001

1	Reel cover
2	Rod
3	Cover adjustment plate

Operating Machine and Mower Units

2. Secure the reel cover to a different hole in the cover adjustment plate.

Note:

If the fin is installed, the reel cover cannot be fully closed.

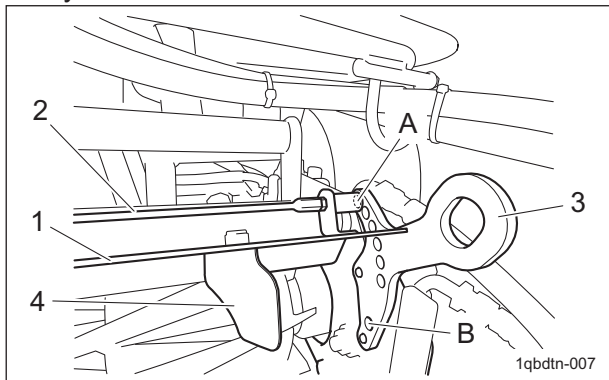

Adjustment of Reel Cover (Variable Easy Latch Type)_002

1	Reel cover
2	Rod
3	Cover adjustment plate
4	Fin
A	Fully open
B	Fully closed

2. Adjust the CR brush so that there is a clearance of 0 to 1.0 mm (0 to 0.039 in) between it and the rear roller, and then firmly tighten the loosened bolts and nuts.

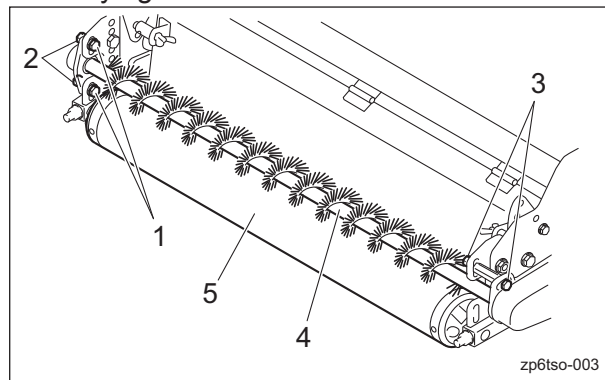

Adjustment of CR Brush_001

1	Bolt A
2	Nut
3	Bolt B
4	Brush
5	Rear roller

Adjustment of CR brush

Adjustment of CR Brush

Note:

Depending on the specifications, this function may not be available.

Caution

If the contact between the brush and rear roller is too tight, the belt may slip or break.

Important

The rotating CR brush prevents grass clippings, etc., from attaching to the rear roller.

1. Loosen the bolts A, bolts B and nuts used to install the CR brush.

Operating Machine and Mower Units

Adjustment of Scraper

Adjustment of Front Scraper

Note:
Depending on the specifications, this function may not be available.

⚠ Caution

If the contact between the scraper and the front roller is too tight, the scraper may become deformed or the front roller may be shaved.

The scraper prevents grass clippings, etc., from attaching to the front roller.

1. Loosen the left and right bolts of the scraper.

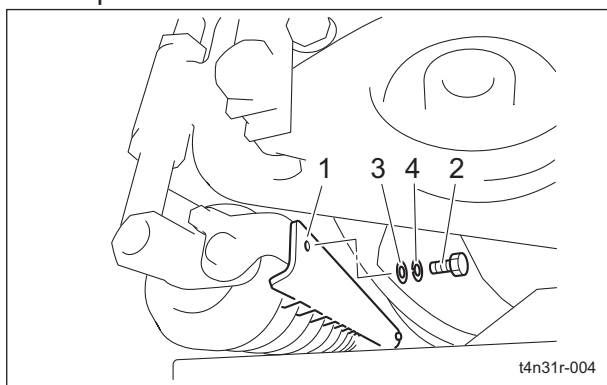

Adjustment of Front Scraper_001

1	Scraper
2	Bolt
3	Washer
4	Spring washer

2. Adjust the scraper so that there is a clearance of 2.0 to 3.0 mm (0.079 to 0.118 in) between it and the outer diameter surface of the front roller, and then firmly tighten the loosened bolts and nuts.

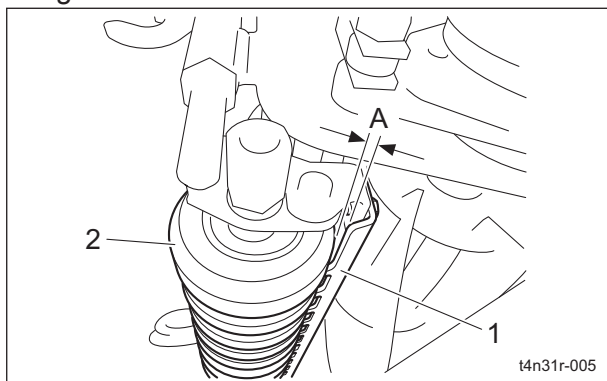

Adjustment of Front Scraper_002

1	Scraper
2	Front roller
A	2.0 - 3.0 mm (0.079 - 0.118 in)

Adjustment of Rear Scraper (Wire Type)

Note:
Depending on the specifications, this function may not be available.

⚠ Caution

If the contact between the scraper and the rear roller is too tight, the scraper may break or sag.

The scraper prevents grass clippings, etc., from attaching to the rear roller.

1. Loosen the left and right lock nuts and nuts of the scraper.
2. Adjust the scraper so that there is a clearance of 2.0 to 3.0 mm (0.079 to 0.118 in) between it and the rear roller, and then secure it with the lock nuts.

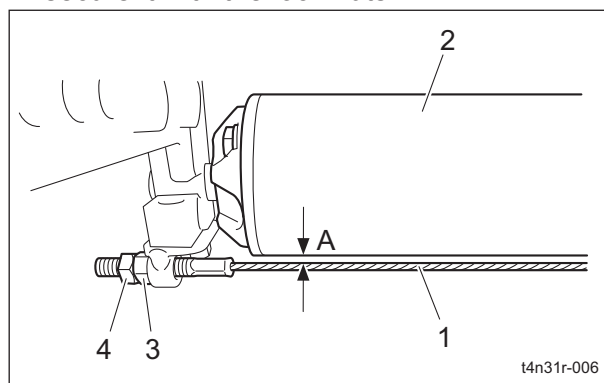

Adjustment of Rear Scraper (Wire Type)_001

1	Scraper
2	Rear roller
3	Nut
4	Lock nut
A	2.0 - 3.0 mm (0.079 - 0.118 in)

Operating Machine and Mower Units

Adjustment of Belt Tension

Caution

Be sure to stop the engine before adjusting the belts.

Important

Make sure that the belt has the specified amount of tension.
Before making sure of its specified tension, rotate the belt several times.

The belt tension is appropriate when the belt slacks by approximately 5.0 to 6.0 mm (0.197 to 0.236 in) when you apply a force of 10.0 N (1.0 kgf) with your finger to the belt at the middle point between the pulleys.

If the belt becomes slack due to frequent use, it may jump or slip.
In addition, if it is overtightened, it may wear prematurely.
If necessary, adjust it, and always check the belt for appropriate tension.

CR Brush Drive Belt

Note:
Depending on the specifications, this function may not be available.

Caution

Be sure to stop the engine before adjusting the belts.

1. Remove the belt cover.
2. Check the belt tension.
3. If the belt tension is inappropriate, adjust the belt tension with the tension pulley adjustment bolt.

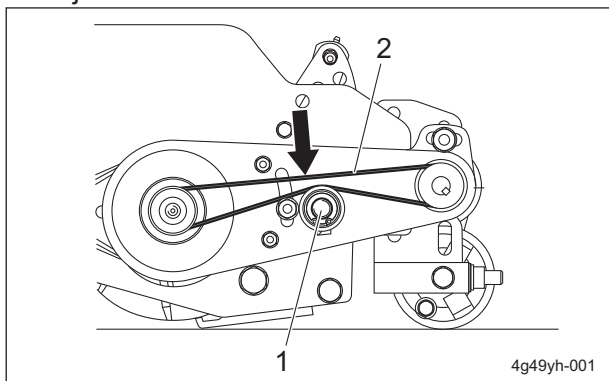

CR Brush Drive Belt_001

1	Tension pulley adjustment bolt
2	Belt

Operating Machine and Mower Units

Removal and installation of each section

Reel cover

Removal of Reel Cover (variable type)

Caution

Both the reel cutter (cutting cylinder) and the bed knife (bottom blade) are edged tools. Handle them carefully, since they could cut your hands and feet.

1. Remove the U nut and disc spring washer from the front roller side, and then remove the fin.

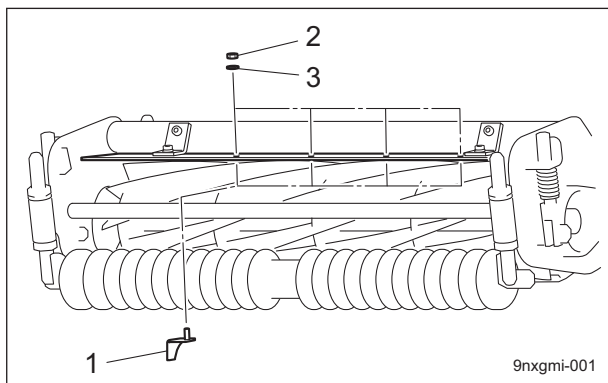

Removal of Reel Cover (variable type)_001

1	Fin
2	U nut
3	Disc spring washer

2. Remove the nuts, spring washers, and washers of the left and right cover mounting plate, then remove the reel cover from the cover mounting plate.

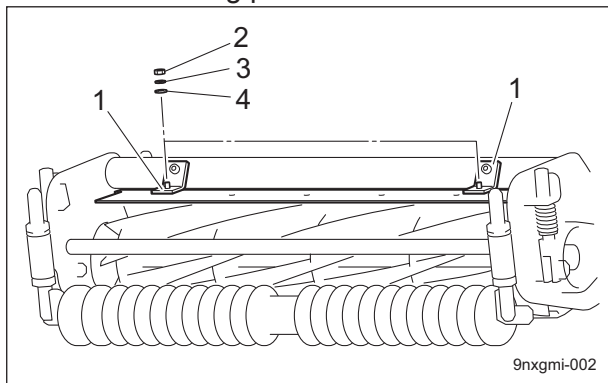

Removal of Reel Cover (variable type)_002

1	Cover mounting plate
2	Nut
3	Spring washer
4	Washer
5	Reel cover

3. Pull the left and right wing nuts on the rear roller side in the direction of the arrow, and pull the lock pin out from the fixing hole of the cover adjustment plate.

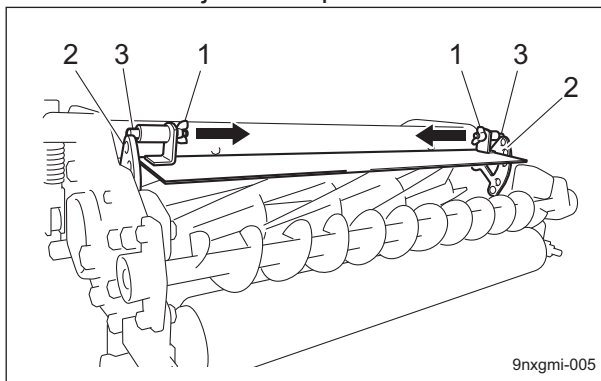

Removal of Reel Cover (variable type)_003

1	Wing nut
2	Cover adjustment plate
3	Lock pin

4. With the variable cover opened, slide the reel cover in the direction of the arrow and remove it from the mower unit.

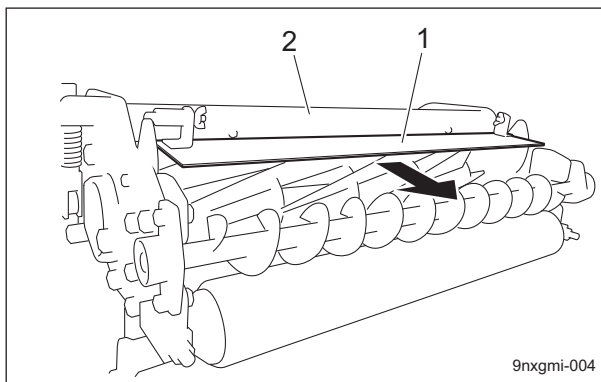

Removal of Reel Cover (variable type)_004

1	Reel cover
2	Mower unit

Operating Machine and Mower Units

Removal of Reel Cover (fixed type, rear discharge)

⚠ Caution

Both the reel cutter (cutting cylinder) and the bed knife (bottom blade) are edged tools. Handle them carefully, since they could cut your hands and feet.

1. Remove the cover mounting plate nuts, spring washers and washers securing the reel cover.

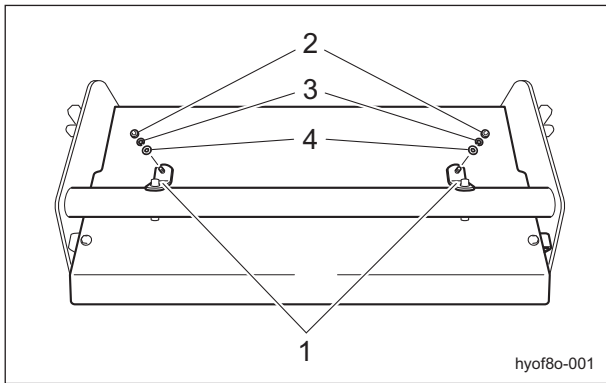

Removal of Reel Cover (fixed type, rear discharge)_001

1	Cover mounting plate
2	Nut
3	Spring washer
4	Washer

2. Remove the cover mounting plate bolts, spring washers and washers securing the reel cover.

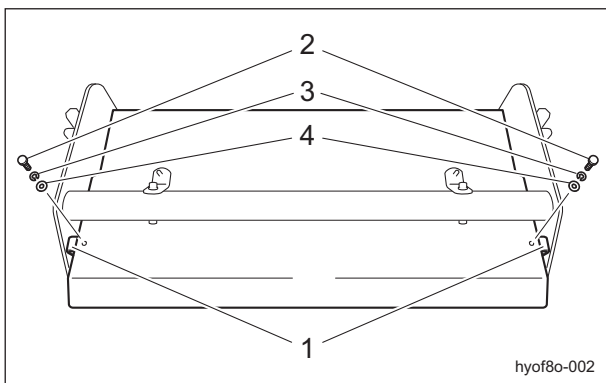

Removal of Reel Cover (fixed type, rear discharge)_002

1	Cover mounting plate
2	Bolt
3	Spring washer
4	Washer

3. Slide the reel cover in the direction of the arrow and remove it from the mower unit.

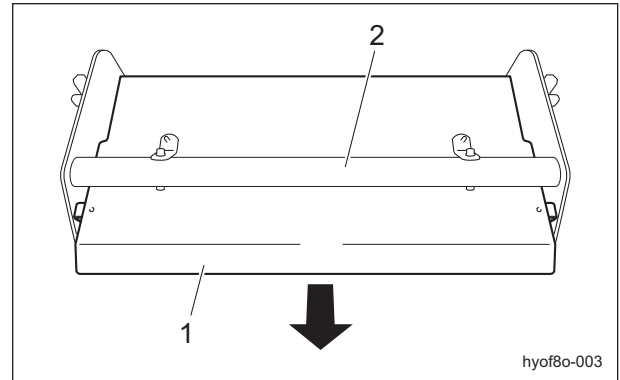

Removal of Reel Cover (fixed type, rear discharge)_003

1	Reel cover
2	Mower unit

Removal of Reel Cover (fixed type, front discharge)

⚠ Caution

Both the reel cutter (cutting cylinder) and the bed knife (bottom blade) are edged tools. Handle them carefully, since they could cut your hands and feet.

1. Remove the cover mounting plate bolts, nuts, washers and spring washers securing the reel cover.

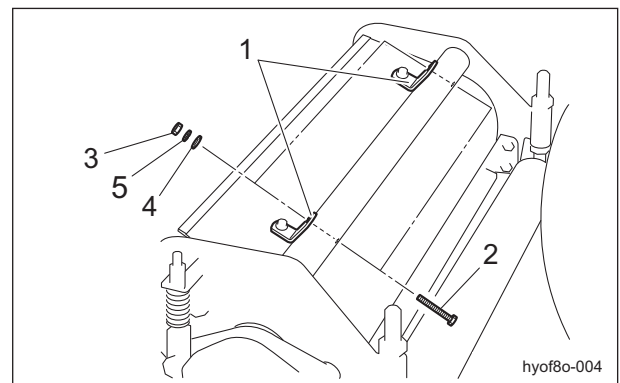

Removal of Reel Cover (fixed type, front discharge)_001

1	Cover mounting plate
2	Bolt
3	Nut
4	Washer
5	Spring washer

Operating Machine and Mower Units

2. Slide the reel cover in the direction of the arrow and remove it from the mower unit.

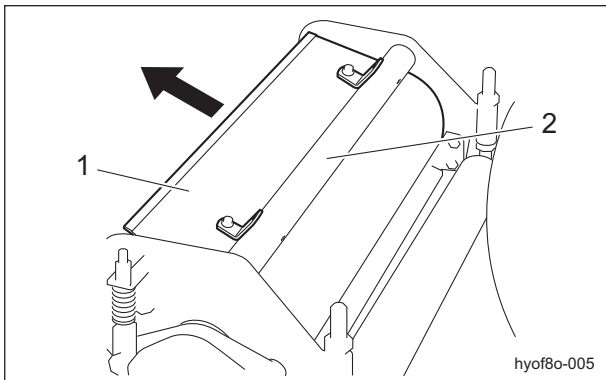

Removal of Reel Cover (fixed type, front discharge)_002

1	Reel cover
2	Mower unit

3. Remove the cover mounting plate nuts, spring washers, washers and bolts from the reel cover.

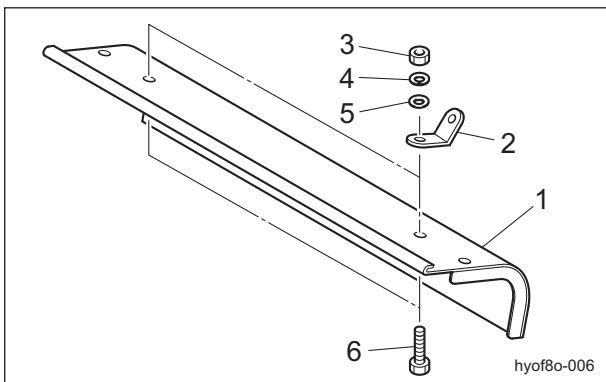

Removal of Reel Cover (fixed type, front discharge)_003

1	Reel cover
2	Cover mounting plate
3	Nut
4	Spring washer
5	Washer
6	Bolt

Installation of Reel Cover

⚠ Danger

Both the reel cutter (cutting cylinder) and the bed knife (bottom blade) are edged tools. Handle them carefully, since they could cut your hands and feet.

⚠ Caution

"Tightening torques" (Page 3-5) See the list. Note that the Baroness product warranty may not apply to defects caused by incorrect or overtightening, etc.

For installation, reverse the removing procedure.

Operating Machine and Mower Units

Bed Knife Mounting Assy

Removal of Bed Knife Base Assy

⚠ Caution

Both the reel cutter (cutting cylinder) and the bed knife (bottom blade) are edged tools. Handle them carefully, since they could cut your hands and feet.

⚠ Caution

When placing the mower unit on top of pieces of wood, check thoroughly that the mower unit is stable.

⚠ Caution

When removing the bed knife base assy from the mower unit, take care not to drop it and cause injury as it is heavy.

1. Remove the mower unit.
2. Turn the mower unit upside-down.
3. Place pieces of wood under the left and right front roller brackets, and place the mower unit on top.
4. Tighten the cutter adjustment nut, and make some space between the reel cutter and the bed knife.

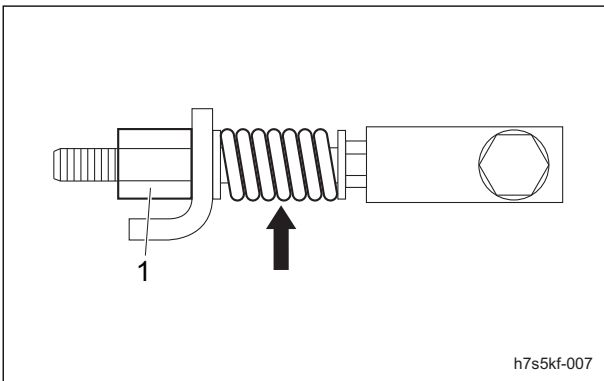

Removal of Bed Knife Base Assy_001

1	Cutter adjustment nut
---	-----------------------

5. Loosen bolts A and spring washers A fastening the bed knife base assy on the left and right rear sides.
6. Loosen front left and right bolts B and spring washers B.

7. Remove all loosened bolts and spring washers.

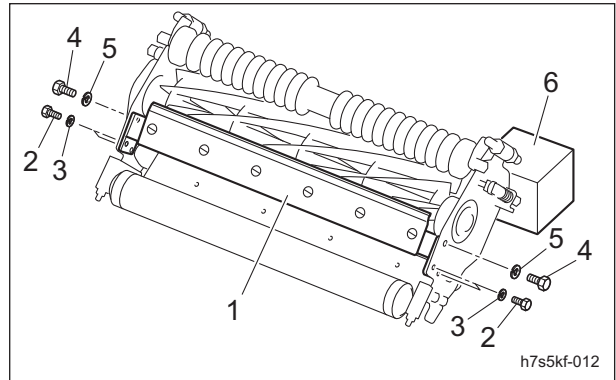

Removal of Bed Knife Base Assy_002

1	Bed knife base assy
2	Bolt A
3	Spring washer A
4	Bolt B
5	Spring washer B
6	Piece of wood

8. Lift up the bed knife base assy, and then pull out it keeping its horizontal attitude to remove it from the mower unit.

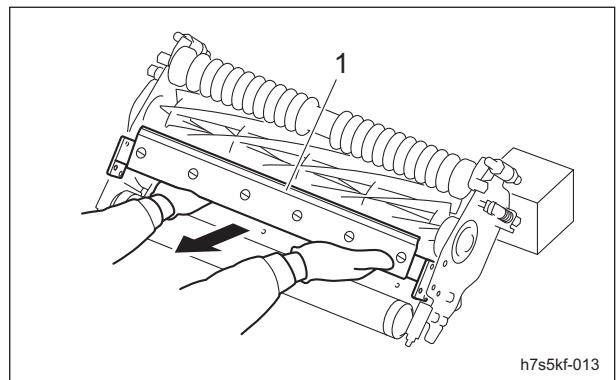

Removal of Bed Knife Base Assy_003

1	Bed knife base assy
---	---------------------

Operating Machine and Mower Units

Installation of Bed Knife Base Assy

Caution

Both the reel cutter (cutting cylinder) and the bed knife (bottom blade) are edged tools. Handle them carefully, since they could cut your hands and feet.

Caution

When placing the mower unit on top of pieces of wood, check thoroughly that the mower unit is stable.

Caution

Refer to the Tightening Torque Table. Note that the Baroness product warranty may not apply to defects caused by incorrect or overtorque tightening, etc.

Caution

When handling the reel cutter or bed knife, wear gloves to protect your hands. Pay attention not to let the reel cutter (cutting cylinder) catch your gloves during your rotating it. Otherwise, you may injure your hand or fingers.

1. Insert the bed knife base assy keeping its horizontal attitude into the mower unit.
Note:
 If you cannot insert it by hand, tap it with a plastic hammer.
 Do not allow the reel cutter to come in contact with the bed knife.
2. Temporarily install rear left and right bolts A and spring washers A used to install the bed knife base.

3. Temporarily install front left and right bolts B and spring washers B.

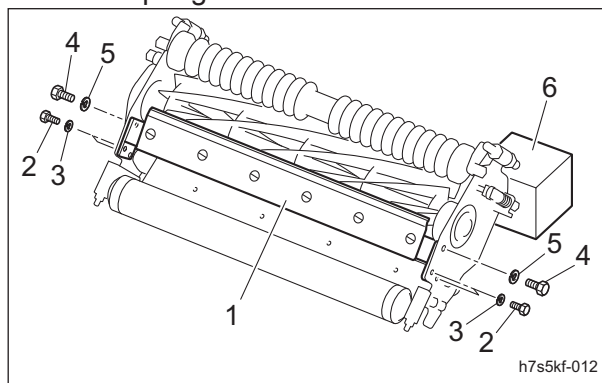

Installation of Bed Knife Base Assy_001

1	Bed knife base assy
2	Bolt A
3	Spring washer A
4	Bolt B
5	Spring washer B
6	Piece of wood

4. Tighten bolts A and B.
5. Adjust blade engagement.
 "Adjustment of Blade Engagement" (Page 4-7)
6. Adjust it by using the pipe with cutter adjusting screw so that the length of the spring coil will be approximately 40.0 mm (1.575 in).

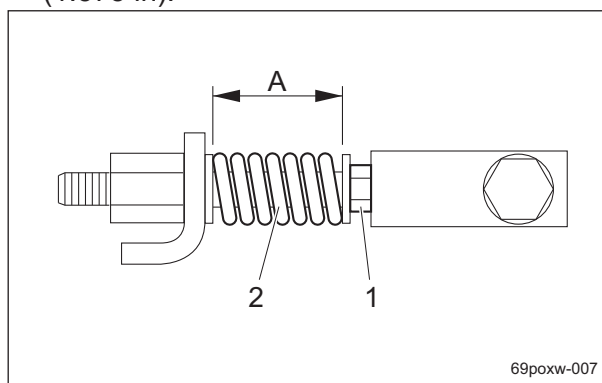

Installation of Bed Knife Base Assy_002

1	Pipe with cutter adjustment screw
2	Cutter adjustment spring
A	40.0 mm (1.575 in)

7. Adjust the cutting height.
 "Cutting Height Adjustment" (Page 4-8)

Operating Machine and Mower Units

Bed knife

Removal of Bed Knife

Caution

Both the reel cutter (cutting cylinder) and the bed knife (bottom blade) are edged tools. Handle them carefully, since they could cut your hands and feet.

Caution

If removing the bed knife base assy from the mower unit, take care not to drop it and cause injury as it is heavy.

1. Remove the bed knife base assy. "Removal of Bed Knife Base Assy" (Page 4-16)
2. Place the bed knife base assy on a stable stage.
3. Remove the screws using an impact driver or punch, and then remove the bed knife from the bed knife base.

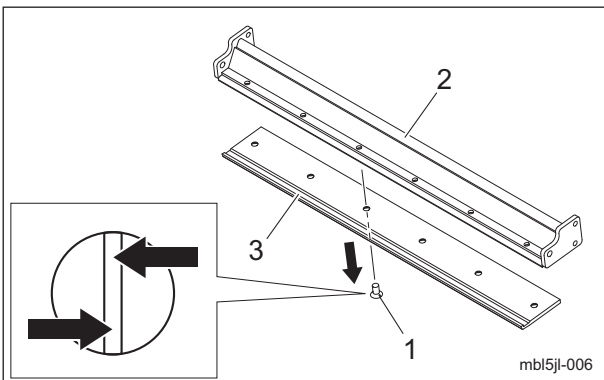

Removal of Bed Knife_001

1	Screw
2	Bed knife base
3	Bed knife

Installation of Bed Knife

Caution

Both the reel cutter (cutting cylinder) and the bed knife (bottom blade) are edged tools. Handle them carefully, since they could cut your hands and feet.

Caution

Refer to the Tightening Torque Table. Note that the Baroness product warranty may not apply to defects caused by incorrect or overtorque tightening, etc.

Important

Be careful not to damage the knife mounting surface of bed knife base. Clean off any rust or dirt.

Important

Replace the screws with new ones.

1. Tighten the screws evenly using an impact driver, and install the bed knife to the bed knife base.



Installation of Bed Knife_001

1	Screw
2	Bed knife base
3	Bed knife

Operating Machine and Mower Units

Note:
When installing the bed knife, first tighten the center screw, and then tighten from center outwards, alternating between left and right sides.

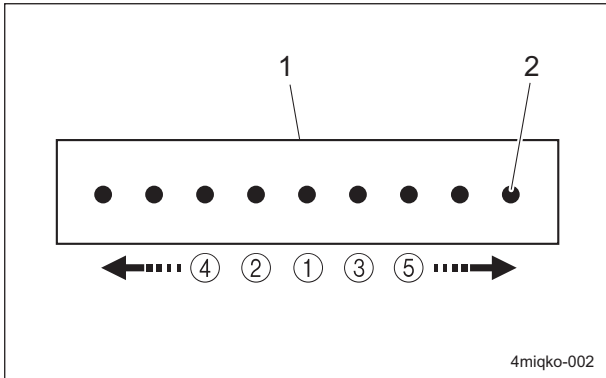

Installation of Bed Knife_002

1	Bed knife
2	Screw

Reel Cutter

Removal of Reel Cutter

Caution

Both the reel cutter (cutting cylinder) and the bed knife (bottom blade) are edged tools. Handle them carefully, since they could cut your hands and feet.

1. Remove the bed knife base assy. "Removal of Bed Knife Base Assy" (Page 4-16)
2. Remove the bolt and spring washer.
3. Remove the reel housing lid and packing.

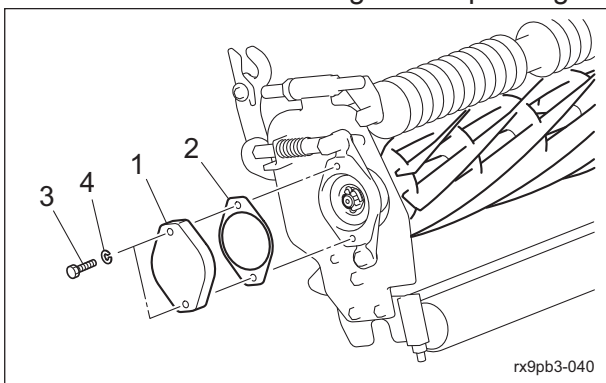

Removal of Reel Cutter_001

1	Reel housing lid
2	Packing
3	Bolt
4	Spring washer

4. Remove the cotter pin.

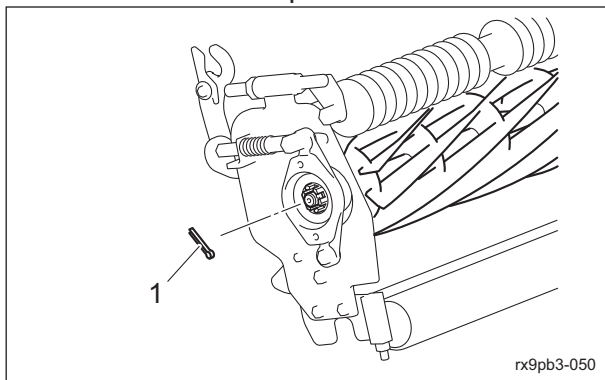

Removal of Reel Cutter_002

1	Cotter pin
---	------------

5. Secure the reel cutter with a wooden board.
6. Loosen the left and right slotted nuts with a socket wrench or similar tool.

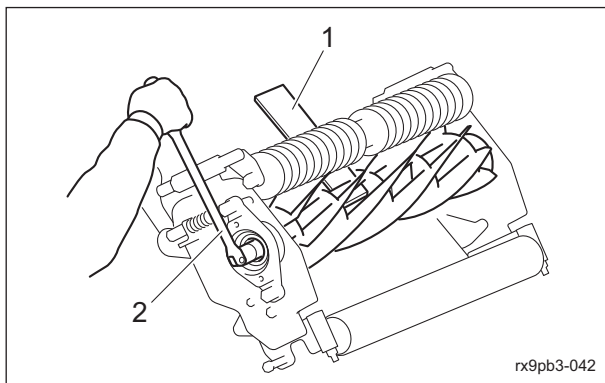

Removal of Reel Cutter_003

1	Wood board
2	Socket wrench

7. Remove the collar.

Caution

When placing the mower unit on top of pieces of wood, check thoroughly that the mower unit is stable.

8. Turn the mower unit upside-down.
9. Place pieces of wood under the left and right cutter adjustment screws, and place the mower unit on top.

Operating Machine and Mower Units

10. Remove the left and right cutter adjustment parts.

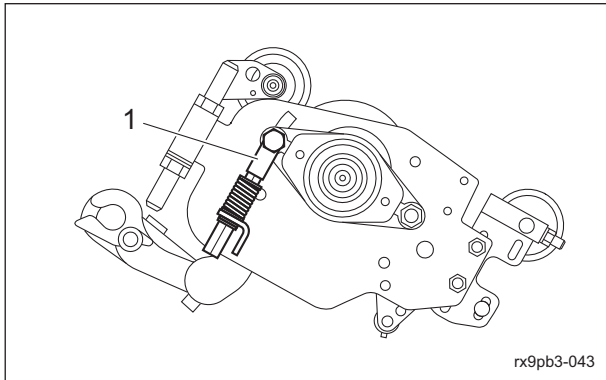

Removal of Reel Cutter_004

1	Cutter adjustment parts
---	-------------------------

[1] Remove the left and right cutter adjustment nuts and washers.

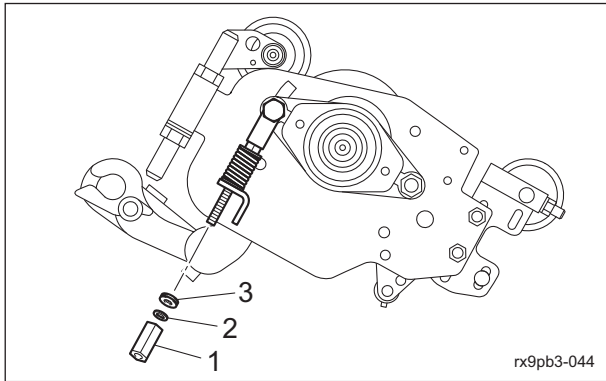

Removal of Reel Cutter_005

1	Cutter adjustment nut
2	Washer
3	Spherical washer

[2] Remove the nuts and washers B which are fixing the left and right housing bolts.

[3] Loosen the left and right housing bolts, and remove the disc spring washers and washers A.

[4] Remove the housing bolts.

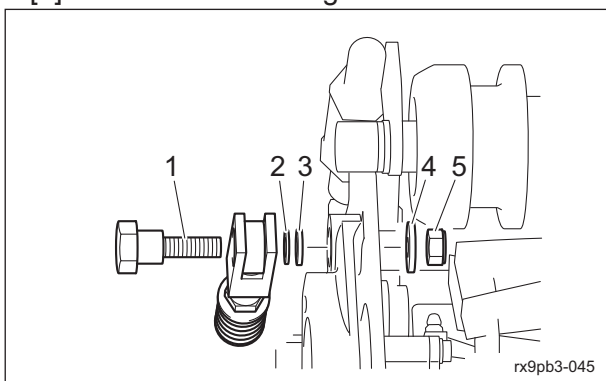

Removal of Reel Cutter_006

1	Housing bolt
2	Disc spring washer
3	Washer A
4	Washer B
5	Nut

11. Remove the nuts installed on the left and right housing spindle bolts, and remove the spindle bolts and washers.

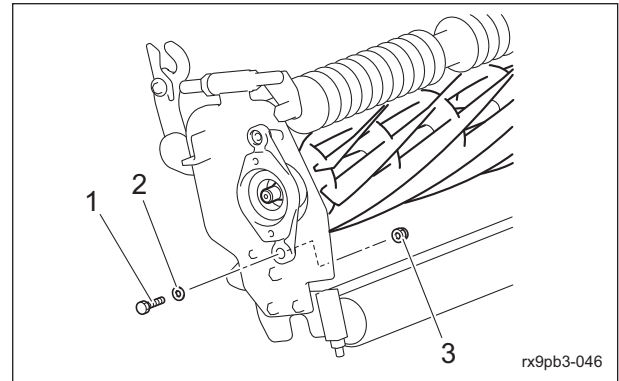

Removal of Reel Cutter_007

1	Spindle bolt
2	Washer
3	Nut

12. To remove the reel housing, install the sliding hammer mounting bracket to the reel housing, using a sliding hammer.

13. Install bolts A using the $\phi 10$ holes of the mounting bracket.

14. Install the sliding hammer with bolt B and nut.

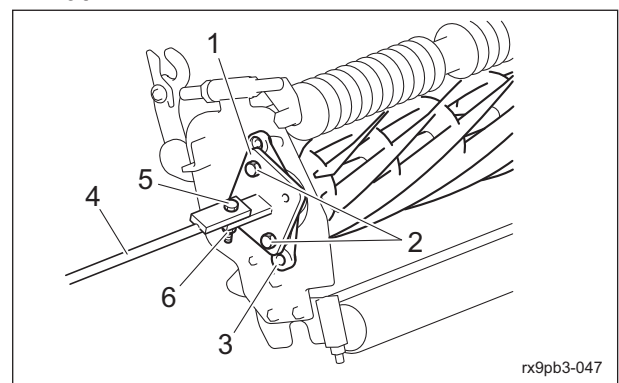

Removal of Reel Cutter_008

1	Mounting bracket
2	Bolt A
3	Reel housing
4	Sliding hammer
5	Bolt B
6	Nut

Operating Machine and Mower Units

Caution

When sliding the hammer, be careful of the holding position not to pinch your fingers.

Important

The hydraulic motor housing differs depending on the mower unit. Remember which mower unit the hydraulic motor housing belongs to.

- Slide the hammer and remove the reel housing by its impact.

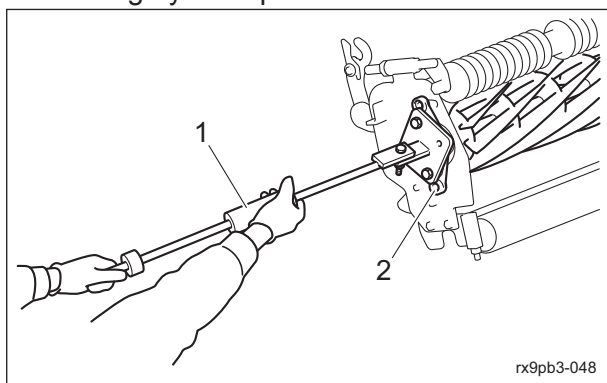

Removal of Reel Cutter_009

1	Hammer
2	Reel housing

- Follow the same steps to remove the hydraulic housing of the other side.

Important

The reel cutter differs depending on the mower unit. Remember which mower unit the reel cutter belongs to.

- Lift the end of the reel cutter and the other end to remove from the mower unit.

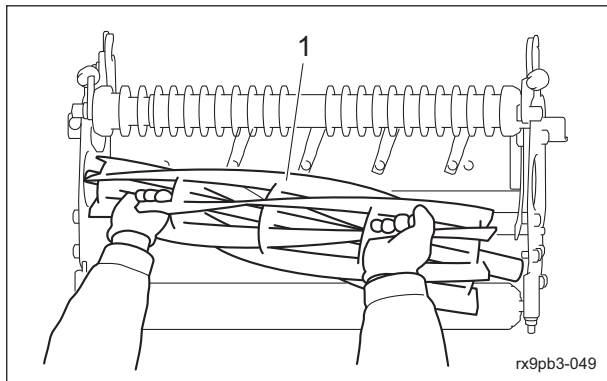

Removal of Reel Cutter_010

1	Reel cutter
---	-------------

Attaching Reel Cutter (Cutting Cylinder)

Caution

Both the reel cutter (cutting cylinder) and the bed knife (bottom blade) are edged tools. Handle them carefully, since they could cut your hands and feet.

Caution

Refer to the Tightening Torque Table. Note that the Baroness product warranty may not apply to defects caused by incorrect or overtightening, etc.

Important

The reel cutter and hydraulic motor housing differ depending on the mower unit. Be careful of the difference.

- Turn the mower unit upside-down.
- Place the reel cutter in the mower unit in the correct direction.
- Lift up the reel cutter and insert the reel housing and hydraulic motor housing.

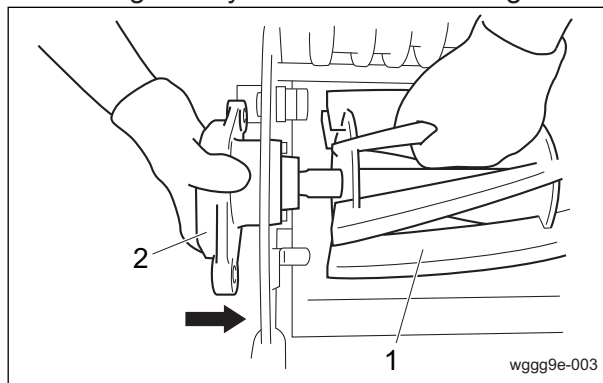

Attaching Reel Cutter (Cutting Cylinder)_001

1	Reel cutter
2	Reel housing

Operating Machine and Mower Units

4. Drive in the reel housing with a plastic hammer to some extent.

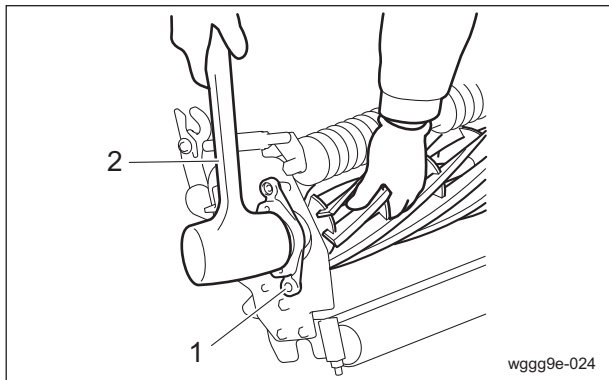

Attaching Reel Cutter (Cutting Cylinder)_002

1	Reel housing
2	Plastic hammer

5. Temporarily install the spindle bolt, washer, and nut on the hydraulic motor housing side.

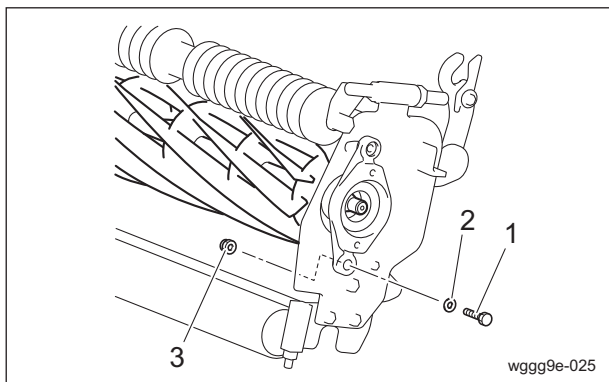

Attaching Reel Cutter (Cutting Cylinder)_003

1	Spindle bolt
2	Washer
3	Nut

Caution

When placing the mower unit on top of pieces of wood, check thoroughly that the mower unit is stable.

6. Place pieces of wood under the left and right cutter adjustment bolts, and place the mower unit on top.

7. Install the cutter adjustment part with the housing bolt, disc spring washer, and washer A in the hydraulic motor housing side and then temporarily install washer B and U nut.

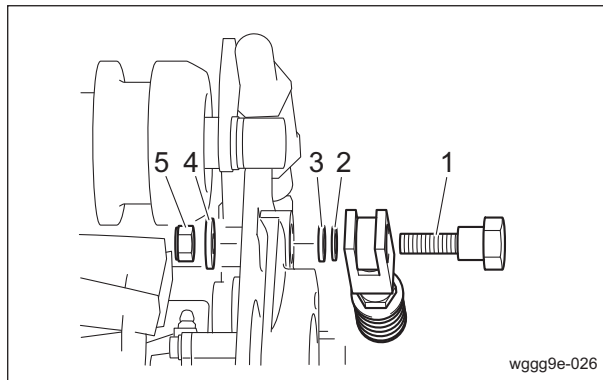

Attaching Reel Cutter (Cutting Cylinder)_004

1	Housing bolt
2	Disc spring washer
3	Washer A
4	Washer B
5	U nut

8. Install the cutter adjustment nut, washer and spherical washer in the hydraulic motor housing side and temporarily install all cutter adjustment parts.

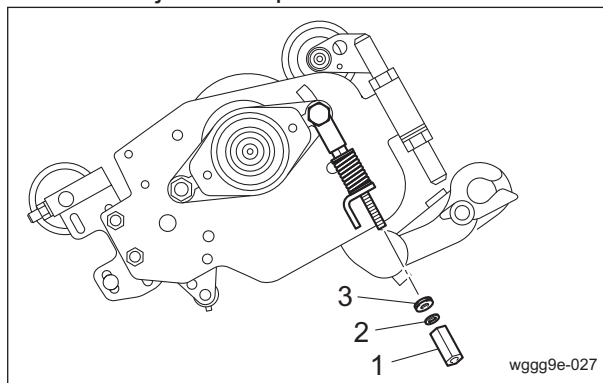

Attaching Reel Cutter (Cutting Cylinder)_005

1	Cutter adjustment nut
2	Washer
3	Spherical washer

Operating Machine and Mower Units

9. Use a bearing driver and tap it with a plastic hammer until there is no play between the hydraulic motor housing and frame.

Note:

If there is play between the frame and reel housing, tap the reel motor housing so that there is no play between the frame and hydraulic motor housing.

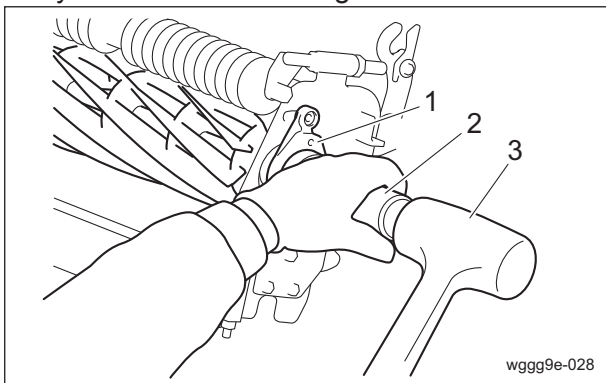

Attaching Reel Cutter (Cutting Cylinder)_006

1	Reel housing
2	Bearing driver
3	Plastic hammer

10. Tighten the spindle bolt on the reel housing side in a way such that the reel housing moves but there is no play, and then lock it with nut.

11. Tighten the spindle bolt on the hydraulic motor housing side as well.

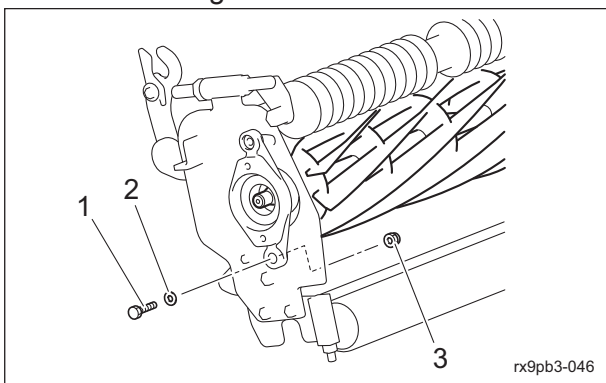

Attaching Reel Cutter (Cutting Cylinder)_007

1	Spindle bolt
2	Washer
3	Nut

12. Install the cutter adjustment part with the housing bolt, disc spring washer, and washer A on the reel housing side, and then temporarily install washer B and U nut.

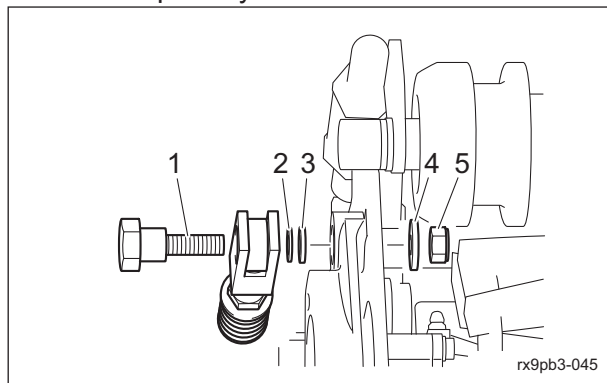

Attaching Reel Cutter (Cutting Cylinder)_008

1	Housing bolt
2	Disc spring washer
3	Washer A
4	Washer B
5	U nut

13. Install the cutter adjustment nut and washer in the reel housing side and then install all cutter adjustment parts.

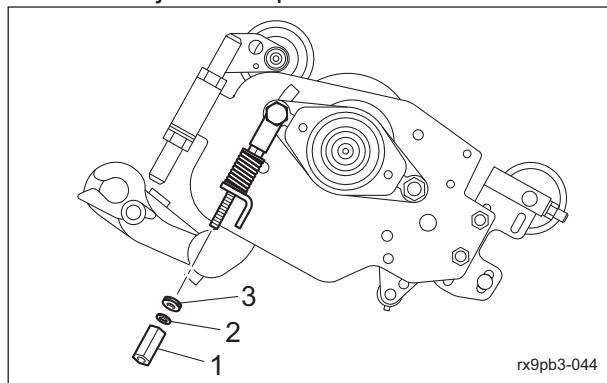

Attaching Reel Cutter (Cutting Cylinder)_009

1	Cutter adjustment nut
2	Washer
3	Spherical washer

Operating Machine and Mower Units

Operating Machine and Mower Units

14. Tighten the left and right housing bolts in a way such that the reel housing and hydraulic motor housing move but there is no play, and then lock them with nuts.

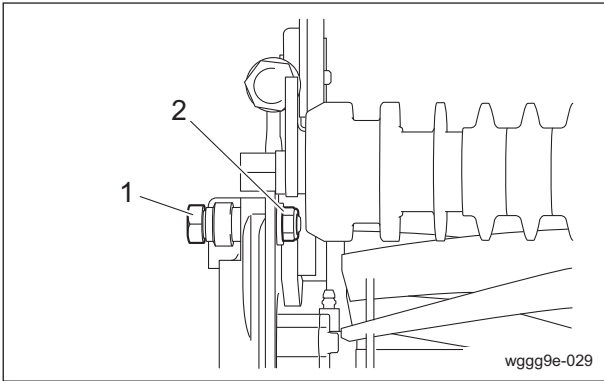

Attaching Reel Cutter (Cutting Cylinder)_010

1	Housing bolt
2	Nut

15. Install a collar and slotted nut onto the reel housing side.

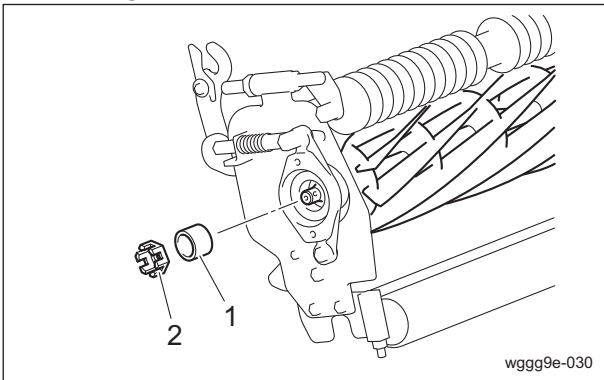

Attaching Reel Cutter (Cutting Cylinder)_011

1	Collar
2	Slotted nut

16. Secure the reel cutter with a piece of wood.
17. Tighten the left and right slotted nuts with a socket wrench or similar tool.

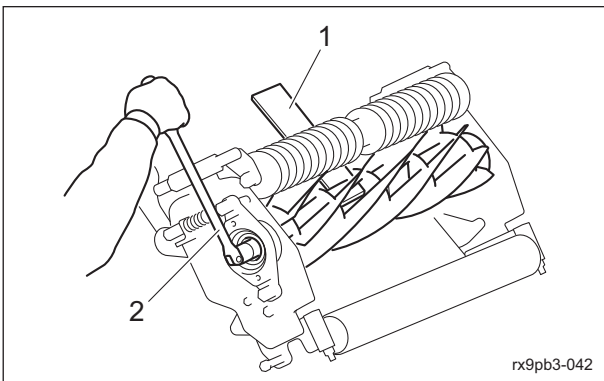

Attaching Reel Cutter (Cutting Cylinder)_012

1	Wood board
2	Box wrench

18. Install the cotter pin.

19. Install the reel housing lid and packing with using a bolt and spring washer.

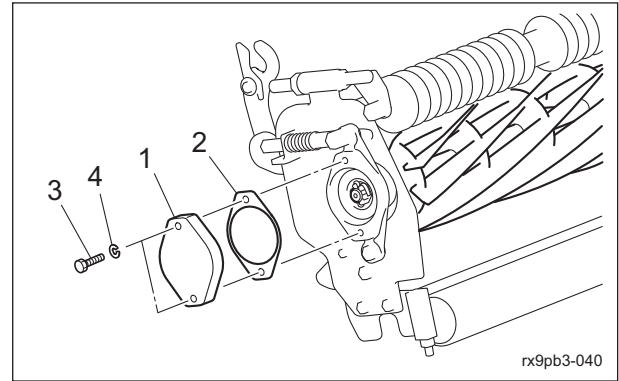

Attaching Reel Cutter (Cutting Cylinder)_013

1	Reel housing lid
2	Packing
3	Bolt
4	Spring washer

20. Tighten the cutter adjustment nut so that there is no clearance with the cutter adjustment spring.

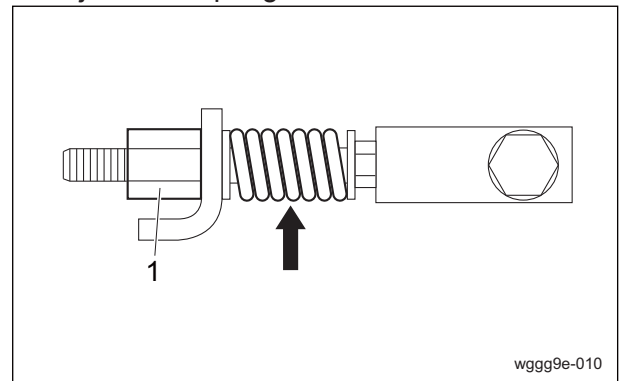

Attaching Reel Cutter (Cutting Cylinder)_014

1	Cutter adjustment nut
---	-----------------------

21. Install the bed knife base assy.
"Installation of Bed Knife Base Assy" (Page 4-17)

22. Adjust blade engagement.
"Adjustment of Blade Engagement" (Page 4-7)

Operating Machine and Mower Units

23. Loosen the pipe with cutter adjustment screw and adjust it so that the length of the spring coil is approximately 40.0 mm (1.575 in).

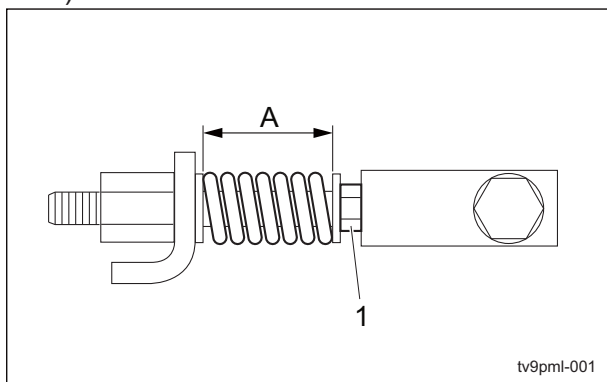

Attaching Reel Cutter (Cutting Cylinder)_015

1	Pipe with cutter adjustment screw
A	40.0 mm (1.575 in)

24. Adjust the cutting height.
"Cutting Height Adjustment" (Page 4-8)

Front Roller Assy

Removal of Front Roller Assy

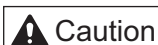

Caution

Both the reel cutter (cutting cylinder) and the bed knife (bottom blade) are edged tools. Handle them carefully, since they could cut your hands and feet.

1. Remove the mower unit.
2. Place the mower unit so that the front roller is at the top.
3. Remove the nuts, spring washers, and washers of the left and right cutting height adjustment screws.

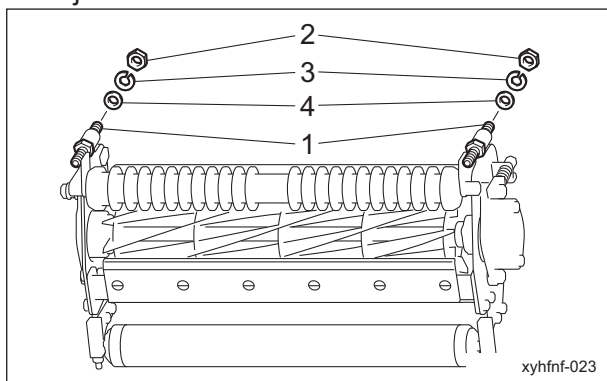

Removal of Front Roller Assy_001

1	Cutting height adjustment screw
2	Nut
3	Spring washer
4	Washer

4. Raise the front roller with both hands and pull it out horizontally with the cutting height adjustment screw installed to remove the roller from the mower unit.

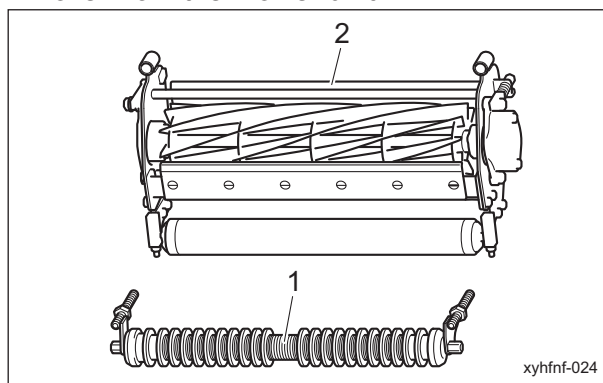

Removal of Front Roller Assy_002

1	Front roller assy
2	Mower unit

5. Remove the left and right nuts, spring washers, cutting height adjustment screws, and grease nipples.

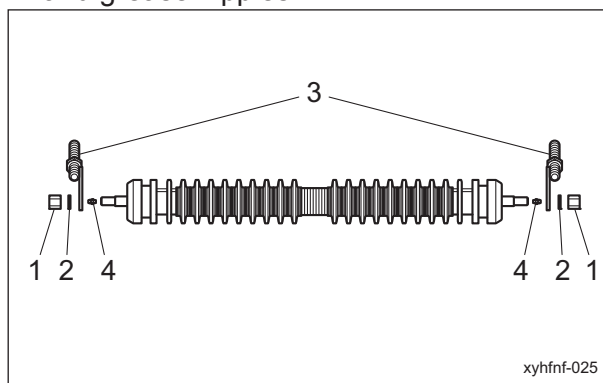

Removal of Front Roller Assy_003

1	Nut
2	Spring washer
3	Cutting height adjustment screw
4	Grease nipple

Operating Machine and Mower Units

Installation of Front Roller Assy

⚠ Caution

Both the reel cutter (cutting cylinder) and the bed knife (bottom blade) are edged tools. Handle them carefully, since they could cut your hands and feet.

⚠ Caution

"Tightening torques" (Page 3-5) See the list. Note that the Baroness product warranty may not apply to defects caused by incorrect or overtorque tightening, etc.

1. For installation, reverse the removing procedure.
2. Rotate the front roller by hand to check the rotation state.
3. Set the gap between the scraper and front roller so that they do not come into contact.
4. Adjust the cutting height.
"Cutting Height Adjustment" (Page 4-8)

Rear Roller Assy

Removal of the Rear Roller Assy

⚠ Caution

Both the reel cutter (cutting cylinder) and the bed knife (bottom blade) are edged tools. Handle them carefully, since they could cut your hands and feet.

1. Remove the mower unit.
2. Place the mower unit so that the rear roller is at the top.
3. Remove the bolts, nuts, spring washers, and washers with which the right and left roller brackets are mounted.

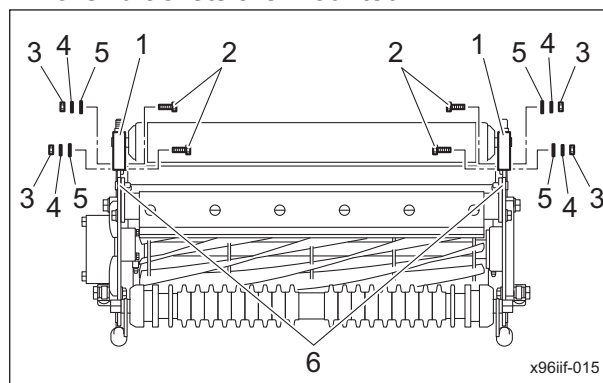

Removal of the Rear Roller Assy_001

1	Roller bracket
2	Bolt
3	Nut
4	Spring washer
5	Washer
6	Frame

4. Lift the rear roller with both hands, and remove it from the mower unit so the left and right are parallel with the roller bracket still installed.

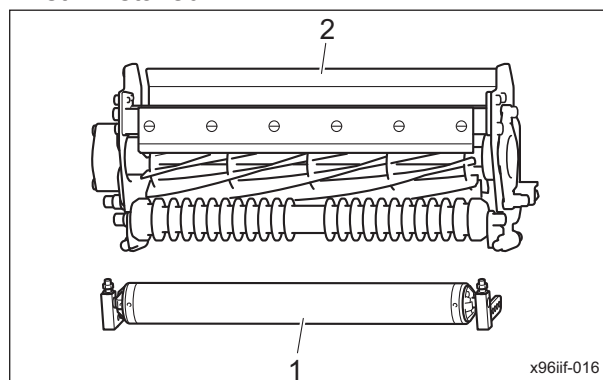

Removal of the Rear Roller Assy_002

Operating Machine and Mower Units

1	Rear roller assy
2	Mower unit

- Loosen the left and right lock nuts and hollow screws.
- Remove the roller bucket.

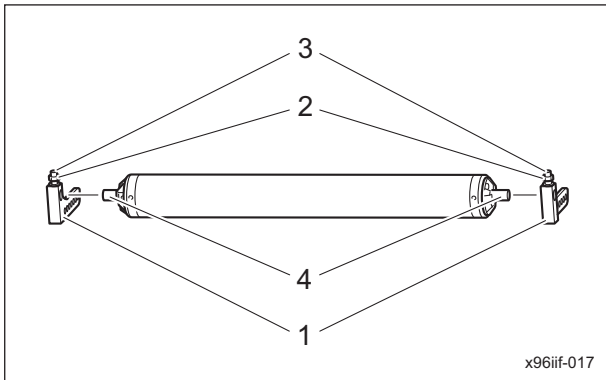

Removal of the Rear Roller Assy_003

1	Roller bracket
2	Lock nut
3	Hollow screw
4	Roller shaft

1	Roller bracket
2	Hollow screw
3	Nut

- Lift the rear roller with both hands, and install it to the mower unit so the left and right are parallel with the roller bracket still installed.

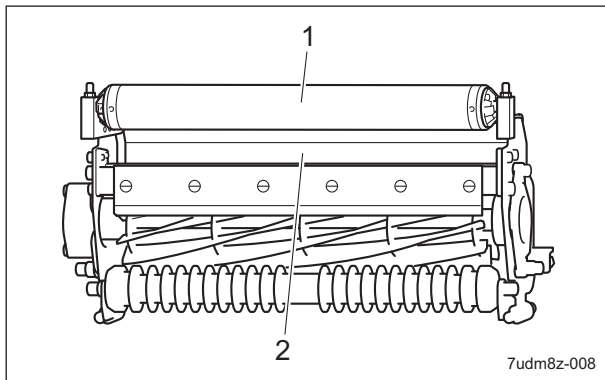

Installation of Rear Roller Assy_002

1	Rear roller assy
2	Mower unit

Installation of Rear Roller Assy

Caution

Both the reel cutter (cutting cylinder) and the bed knife (bottom blade) are edged tools. Handle them carefully, since they could cut your hands and feet.

Caution

"Tightening torques" (Page 3-5) See the list. Note that the Baroness product warranty may not apply to defects caused by incorrect or overtorque tightening, etc.

- Temporarily install the hollow screws and nuts to the left and right roller brackets.

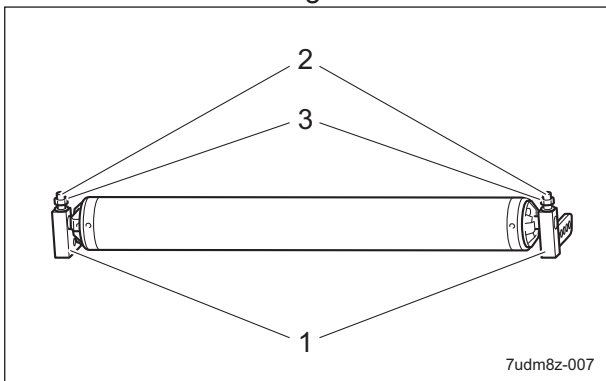

Installation of Rear Roller Assy_001

Important

Align the roller bracket hole positions to the desired cutting height, and install the bolts to the frame holes in the same position left and right.

- Install the bolts, washers and spring washers to the left and right roller bracket and frame, and tighten the nuts.

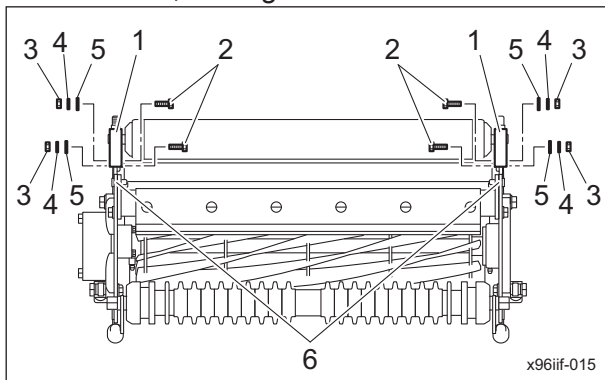

Installation of Rear Roller Assy_003

1	Roller bracket
2	Bolt
3	Nut
4	Spring washer
5	Washer
6	Frame

Operating Machine and Mower Units

4. Install the rear roller assy to the mower unit so that the length of roller shaft protruding from the left and right brackets is even.

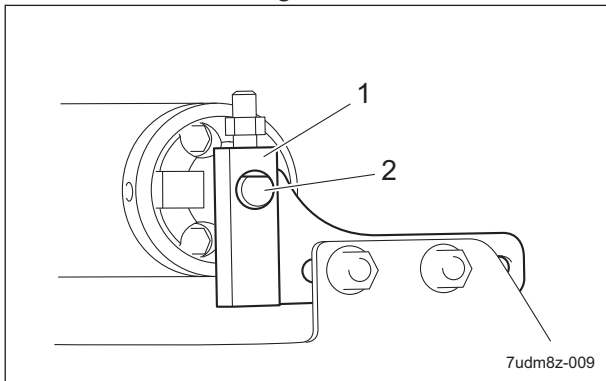

Installation of Rear Roller Assy_004

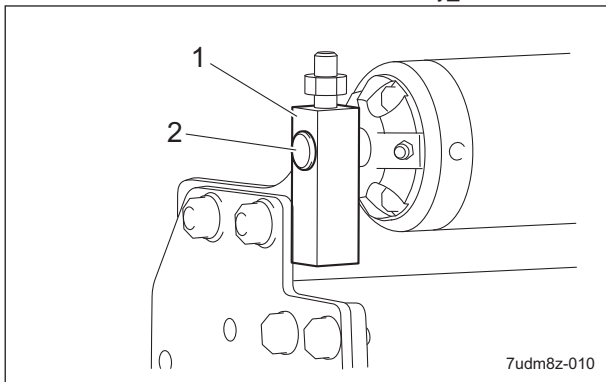

Installation of Rear Roller Assy_005

1	Roller bracket
2	Roller shaft

5. Align the flat section of one side of the roller shaft with the hollow screw positions of the roller bracket.
6. Tighten the hollow screw and nut.

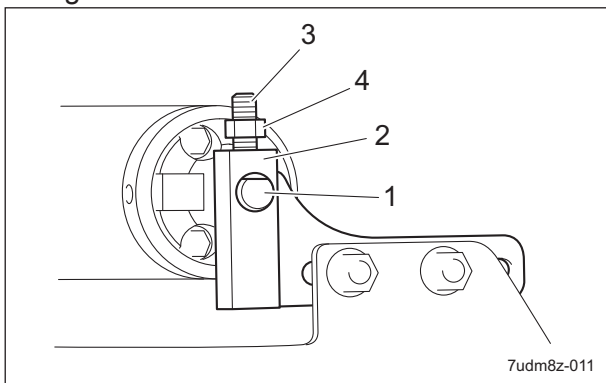

Installation of Rear Roller Assy_006

1	Roller shaft
2	Roller bracket
3	Hollow screw
4	Nut

7. Tighten the hollow screw and nut on the other side as well.

8. Turn the rear roller by hand and confirm how it turns.
9. Adjust the cutting height.
"Cutting Height Adjustment" (Page 4-8)

CR Brush Assy

Removal of CR Brush Assy

Note:
Depending on the specifications, this function may not be available.

⚠ Caution

Both the reel cutter (cutting cylinder) and the bed knife (bottom blade) are edged tools. Handle them carefully, since they could cut your hands and feet.

1. Remove the mower unit.
2. Remove the nuts, spring washers, and washers, and then remove the belt cover.

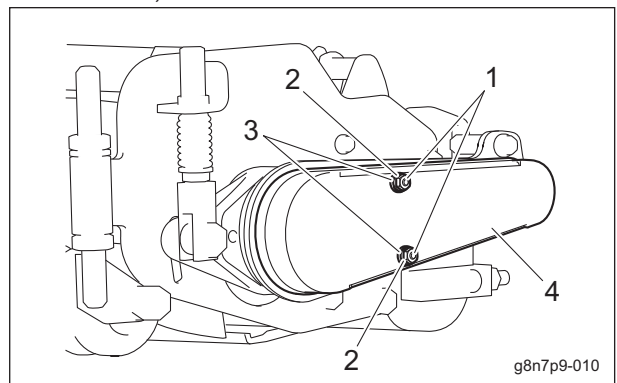

Removal of CR Brush Assy_001

1	Nut
2	Spring washer
3	Washer
4	Belt cover

3. Loosen the bolt, lower the tension pulley and remove the belt.

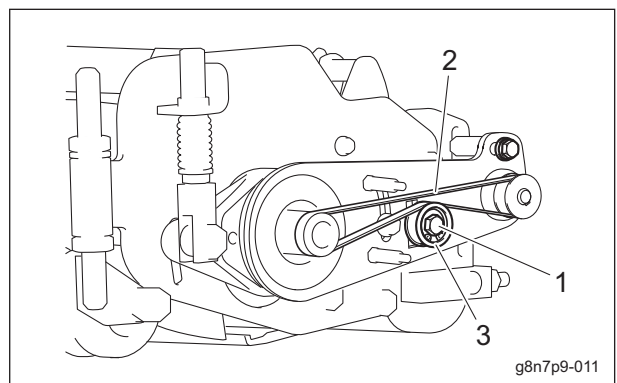

Removal of CR Brush Assy_002

Operating Machine and Mower Units

1	Bolt
2	Belt
3	Tension pulley

4. Remove the U nuts and washer.

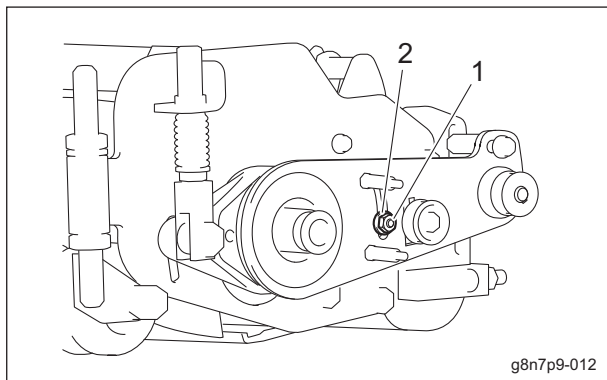

Removal of CR Brush Assy_003

1	U nut
2	Washer

5. Remove the bolt, spring washer, and washer.

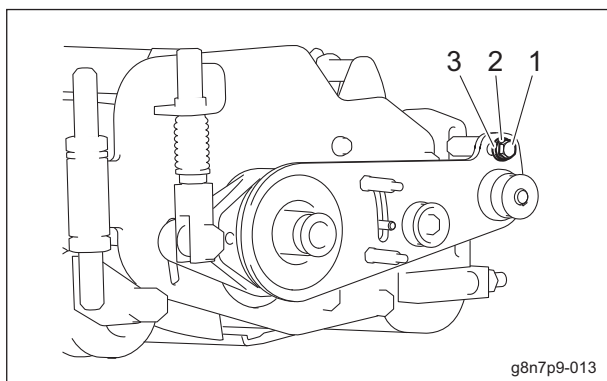

Removal of CR Brush Assy_004

1	Bolt
2	Spring washer
3	Washer

6. Remove the nuts, spring washers, washers and bolts securing the brush shaft housing.

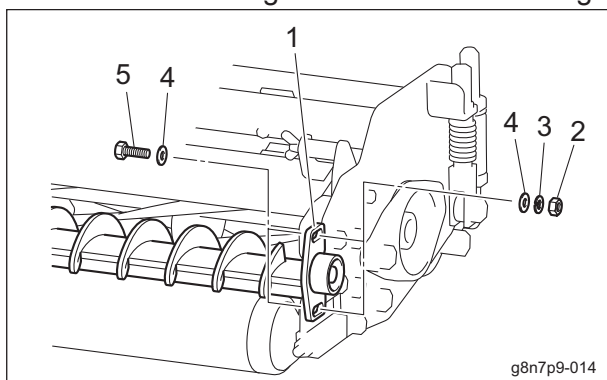

Removal of CR Brush Assy_005

1	Brush shaft housing
2	Nut
3	Spring washer
4	Washer
5	Bolt

7. Remove the CR brush assy in the direction of the arrow.

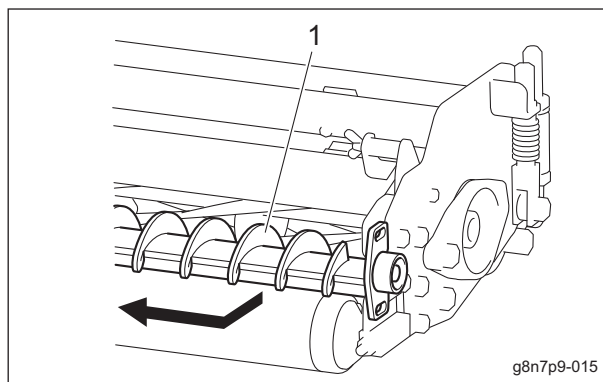

Removal of CR Brush Assy_006

1	CR brush assy
---	---------------

Installation of CR Brush Assy

Note:

Depending on the specifications, this function may not be available.

⚠ Danger

Both the reel cutter (cutting cylinder) and the bed knife (bottom blade) are edged tools. Handle them carefully, since they could cut your hands and feet.

1. For installation, reverse the removing procedure.
2. Adjust the CR brush.
"Adjustment of CR brush" (Page 4-10)

Operating Machine and Mower Units

Inspection and repair of each section

Reel Cover

Due to frequent use, corrosion, or damage during use or transportation, the reel cover may be caught in the reel cutter. Inspect it, and if necessary, replace the parts.

- Check if the safety decals or instruction decals are not peeled off.
- Check if there is no crack, change in shape, etc. on the reel cover.

Refer to "Installation of Reel Cover" (Page 4-15) and "Removal of Reel Cover (variable type)" (Page 4-13) for information on attaching and removing the reel cover.

Reel cutter

Important

Be sure to replace the oil seals and bearings with new ones.

The reel cutter (cutting cylinder) may become dull due to frequent use, objects crushed during mowing, or damage caused during transportation.

Inspect it, and if necessary, grind or replace the reel cutter.

- Make sure that the welding between the reel cutter (cutting cylinder) and the disc has not come off.
- Make sure that the reel cutter is not cracked.
- Check to see whether or not the "relief" surface remains at the point of reel cutter (cutting cylinder).
- Check to see whether or not grinding burn and color change have occurred on the reel cutter.
- Check to see how much the reel cutter is worn.

Refer to "Removal of Reel Cutter" (Page 4-19) and "Attaching Reel Cutter (Cutting Cylinder)" (Page 4-21) for information on attaching and removing the reel cutter.

Back Lapping of Reel Cutter (Cutting Cylinder)

Back lapping is work similar to sharpening a cooking knife. If the edges of the reel cutter (cutting cylinder) and the bed knife (bottom blade) become blunt and make cutting difficult, both the reel cutter (cutting cylinder) and the bed knife (bottom blade) should be simultaneously sharpened by reversing the reel cutter (cutting cylinder) with an abrasive paste applied.

However, back lapping is a temporary measure and would not restore the sharpness completely.

If the edges of the reel cutter (cutting cylinder) and the bed knife (bottom blade) become blunt and make cutting difficult, follow the steps below to perform back lapping.

⚠ Caution

Both the reel cutter (cutting cylinder) and the bed knife (bottom blade) are edged tools. Handle them carefully, since they could cut your hands and feet.

⚠ Caution

Be careful not to inhale exhaust gas during back lapping.

⚠ Caution

During back lapping, the reel cutter (cutting cylinder) rotates. Keep hands and feet away from moving parts.

⚠ Caution

Do not perform back lapping with any other persons.

Operating Machine and Mower Units

1. Have the following items ready: Strips of newspaper, Abrasive [Back lapping powder mixed with oil; or gel compound (Baroness genuine abrasive)], Brush.

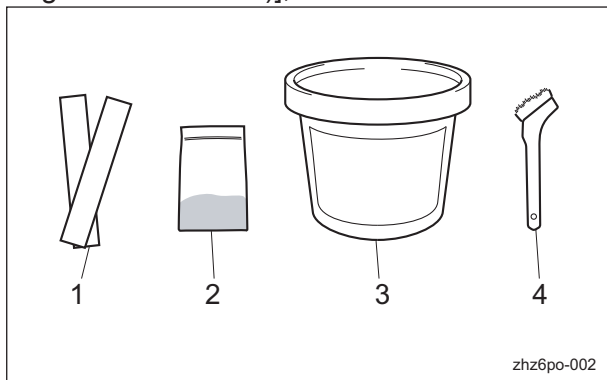

Back Lapping of Reel Cutter (Cutting Cylinder)_001

1	Newspaper
2	Back lapping powder
3	Gel compound
4	Brush

Note:

The mixing ratio for the abrasive, in volume, is one part back lapping powder (#150 - #200) to three or four parts oil.

Caution

When handling the reel cutter (cutting cylinder) or bed knife (bottom blade), wear gloves to protect your hands. However, pay attention not to let the reel cutter (cutting cylinder) catch your gloves, etc. Otherwise, you may injure your hand or fingers.

Important

Check the sharpness of the blade by checking the blade engagement after cutting grass.

2. Stop the engine.

3. Set the reel rotation/stop switching lever to the "Stop" position.

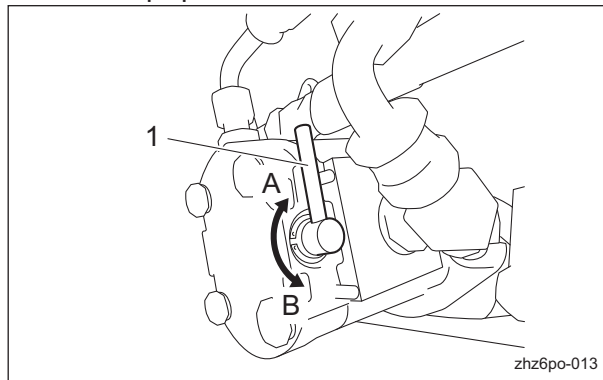

Back Lapping of Reel Cutter (Cutting Cylinder)_002

1	Reel rotation/stop switching lever
A	Rotate
B	Stop

4. Insert two or three strips of newspaper into the space between the reel cutter (cutting cylinder) and the bed knife (bottom blade) at an angle of 90 degrees. Then, rotate the reel cutter (cutting cylinder) counter-clockwise (when you face the mower unit from the left) by hand to check the sharpness of the blades.
5. Check the sharpness of the entire range (three or four points from the left edge to the right one) of the reel cutter (cutting cylinder).
6. With a piece of chalk, etc., mark locations on the blade that are sharp.
7. Shift only the reel rotation/stop switching levers of the hydraulic motors in the mower units to be used for back lapping to the "Rotate" position. Shift the levers to the "Stop" position for the mower units for which you will not perform back lapping.
8. Sit on the seat, apply the parking brake, and then start the engine.

Note:
If the reel rotation switch is set to the "Rotate" position, the engine will not start.
9. Lower all mower units to the ground.
10. Set the reel reverse switch to the "Reverse" position.
11. Run the engine at a low rpm.
12. Set the reel rotation switch to the "Rotate" position to rotate the reel cutter (cutting cylinder) for back lapping.

Operating Machine and Mower Units

13. With the reel rotation/stop switching lever, adjust the rotation speed of the reel cutter (cutting cylinder).
14. Apply the abrasive evenly with the brush on the top side of reel cutter (cutting cylinder) where the newspaper was cut well or of chalk-marked locations. (Never apply to blunt areas.)
15. Idle the machine for a while, and when contact noise is no longer heard, set the reel rotation switch to the "Stop" position to stop the reel cutter (cutting cylinder).
16. Stop the engine.
17. Wash off or wipe off with a cloth, etc., the abrasive from the reel cutter (cutting cylinder), and then check the sharpness.
18. Repeat steps 3 to 17 until the entire range (three or four points from the left edge to the right one) of the reel cutter (cutting cylinder) will be uniformly sharpened.
19. Finally, apply abrasive to the entire blade width of the reel cutter (cutting cylinder) and perform final back lapping.
20. Set the reel rotation switch to the "Stop" position to stop the rotation of the reel cutter (cutting cylinder), stop the engine, and then carefully and thoroughly wash off any remaining abrasive.
21. Set the reel reverse switch to the "Normal rotation" position.
22. Shift the reel rotation/stop switching lever to the "Stop" position.
23. While checking the blade for sharpness, adjust blade engagement.

The sharpening of the reel cutter (cutting cylinder) consists in maintaining its roundness and creating a relief (second edge face). This work should be performed if the sharpness cannot be restored, even after back lapping, or if the relief (second edge face) has worn away.

Sharpen the reel cutter (cutting cylinder) when the sharpness cannot be restored, even after back lapping, or when the relief (second edge face) has worn away, there is full contact or back lapping takes too much time.

In addition, if the reel cutter (cutting cylinder) becomes worn and its shape conical, perform cylindrical grinding to return it to a cylindrical shape.

For sharpening the reel cutter (cutting cylinder), contact your dealer or Baroness. If the outer diameter of the reel cutter (cutting cylinder) after sharpening is more than the usage limit, the reel cutter (cutting cylinder) can be sharpened.

New		Usage limit	
Dimension A (Outer diameter of reel cutter (cutting cylinder))	Dimension B (Distance from blade edge to outer edge of reel cutter (cutting cylinder) shaft)	Dimension A (Outer diameter of reel cutter (cutting cylinder))	Dimension B (Distance from blade edge to outer edge of reel cutter (cutting cylinder) shaft)
163 mm (6.42 in)	68.8 mm (2.71 in)	143 mm (5.63 in)	58.8 mm (2.31 in)

Note:

The outer diameter of the reel cutter (cutting cylinder) shaft is 25.4 mm (1.00 in).

Sharpening of Reel Cutter (Cutting Cylinder)

⚠ Caution

Both the reel cutter (cutting cylinder) and the bed knife (bottom blade) are edged tools. Handle them carefully, since they could cut your hands and feet.

⚠ Caution

Wear gloves when touching edged tools to avoid cutting your hands.

Operating Machine and Mower Units

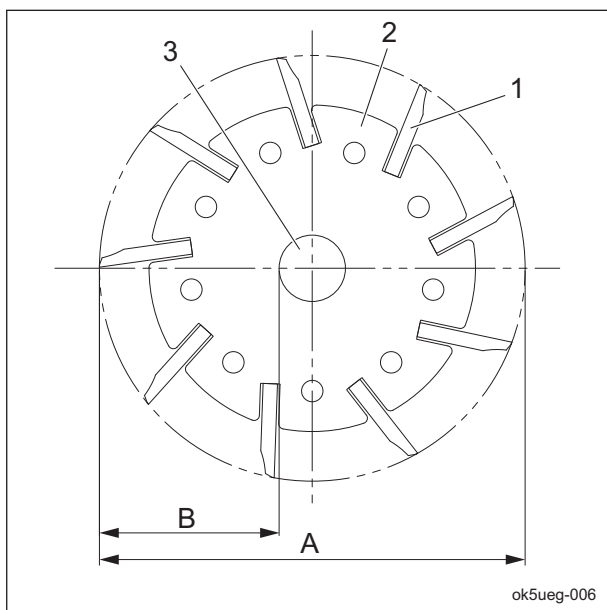

Sharpening of Reel Cutter (Cutting Cylinder)_001

1	Reel cutter (cutting cylinder) blade
2	Reel cutter (cutting cylinder) disc
3	Reel cutter (cutting cylinder) shaft
A	Outer diameter of reel cutter (cutting cylinder)
B	Distance from blade edge to outer edge of reel cutter (cutting cylinder) shaft

Sharpening is necessary when the reel cutter (cutting cylinder) reaches a condition described below.

1. When the sharpening width (length of contacting surface of bed knife (bottom blade)) for the outer diameter of the reel cutter (cutting cylinder) is greater than the usage limit.

Outer diameter of reel cutter (cutting cylinder) (new part)	Usage limit of sharpening width for outer diameter of reel cutter (cutting cylinder)
163 mm (6.42 in)	3.0 mm (0.12 in) (factory-recommended)

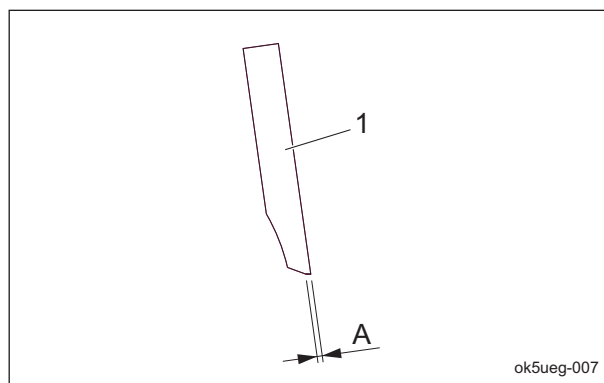

Sharpening of Reel Cutter (Cutting Cylinder)_002

1	Reel cutter (cutting cylinder) blade
A	Sharpening width for outer diameter of reel cutter (cutting cylinder)

2. When the edges become blunt or the blade edge cannot be formed with back lapping
3. When the reel cutter (cutting cylinder) becomes worn and its shape conical, or when blade engagement adjustment cannot be performed

Operating Machine and Mower Units

■ Bearing/Holder for Grinding Machine

These are used for the types of grinding machines which performs centering of the reel cutter with using bearings.

1	Holder assy (φ52)
2	Bearing #6304

3. Adjust the outer diameter of the bearing in the opposite side by using the bearing holder in the hydraulic motor side of the shaft.

- Holder Assy φ60 and Holder Assy φ60-20

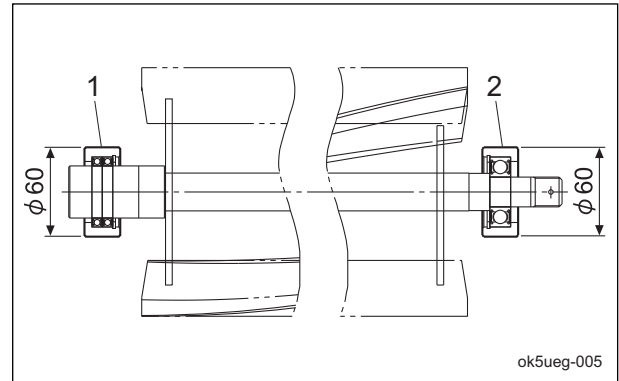

ok5ueg-005

Bearing/Holder for Grinding Machine_003

1	Holder assy (φ60)
2	Holder assy (φ60-20)

Important

Be sure to confirm how to receive the bearings because that method varies among grinding machines.

Important

Use a double-sealed bearing, because dust, dirt, etc. adversely affect the movement of bearings.

1. Use the bearings of #6807 and #6204 for each end of the shaft to adjust the outer diameter.

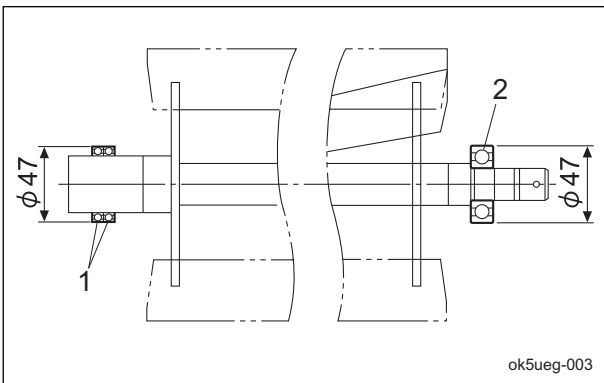

ok5ueg-003

Bearing/Holder for Grinding Machine_001

1	Bearing #6807
2	Bearing #6204

2. Adjust the outer diameter of the bearing in the opposite side by using the bearing holder in the hydraulic motor side of the shaft.

- Bearing holder Assy φ52

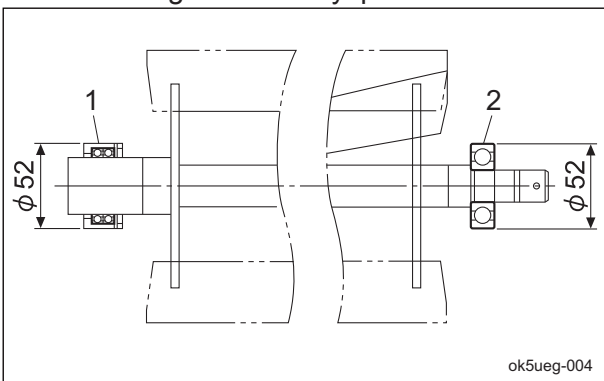

ok5ueg-004

Bearing/Holder for Grinding Machine_002

Operating Machine and Mower Units

Replacement of Reel Cutter (Cutting Cylinder)

⚠ Caution

Both the reel cutter (cutting cylinder) and the bed knife (bottom blade) are edged tools. Handle them carefully, since they could cut your hands and feet.

⚠ Caution

Wear gloves when touching edged tools to avoid cutting your hands.

The criteria for replacing the reel cutter (cutting cylinder) are described below. However, these criteria are only a reference and do not guarantee performance like that of a new reel cutter (cutting cylinder).

1. When the outer diameter of the reel cutter (cutting cylinder) is less than the usage limit

New		Usage limit	
Dimension A (Outer diameter of reel cutter (cutting cylinder))	Dimension B (Distance from blade edge to outer edge of reel cutter (cutting cylinder) shaft)	Dimension A (Outer diameter of reel cutter (cutting cylinder))	Dimension B (Distance from blade edge to outer edge of reel cutter (cutting cylinder) shaft)
163 mm (6.42 in)	68.8 mm (2.71 in)	143 mm (5.63 in)	58.8 mm (2.31 in)

Note:

The outer diameter of the reel cutter (cutting cylinder) shaft is 25.4 mm (1.00 in).

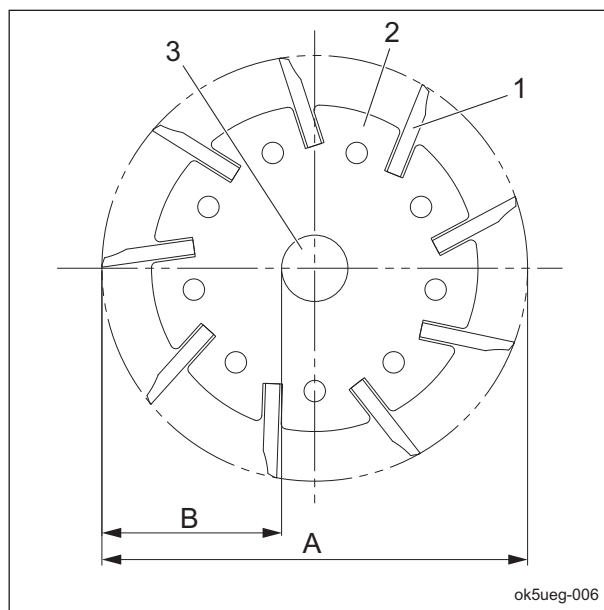

Replacement of Reel Cutter (Cutting Cylinder)_001

1	Reel cutter (cutting cylinder) blade
2	Reel cutter (cutting cylinder) disc
3	Reel cutter (cutting cylinder) shaft
A	Outer diameter of reel cutter (cutting cylinder)
B	Distance from blade edge to outer edge of reel cutter (cutting cylinder) shaft

Operating Machine and Mower Units

Reel Housing

Wear of bearings due to frequent use and/or damage of bearings, etc. caused by invasion of water may prevent smooth rotation of the reel cutter.

Inspect and replace the parts such as the oil seal and bearings.

- Make sure that the reel housing does not have any crack.
- Make sure that the spindle bolt and housing bolt receptacles are not shaky.
- Make sure that the bearing receptacle is not shaky.

⚠ Caution

Both the reel cutter (cutting cylinder) and the bed knife (bottom blade) are edged tools. Handle them carefully, since they could cut your hands and feet.

⚠ Caution

"Tightening torques" (Page 3-5) See the list. Note that the Baroness product warranty may not apply to defects caused by incorrect tightening, etc.

Important

The grease nipple of the reel housing lid has a specific installation direction. Confirm its direction.

Important

The bearing and oil seal have a specific installation orientation. Confirm its direction.

1. Remove the reel housing from the reel cutter.
"Removal of Reel Cutter" (Page 4-19)
2. Remove the grease nipple.

3. Remove the bolt and spring washer of the reel housing.

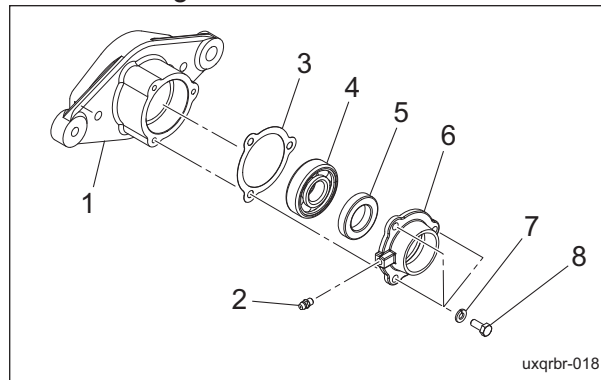

Reel Housing_001

1	Reel housing
2	Grease nipple
3	Packing
4	Bearing
5	Oil seal
6	Housing lid
7	Spring washer
8	Bolt

4. Remove the housing lid and packing.

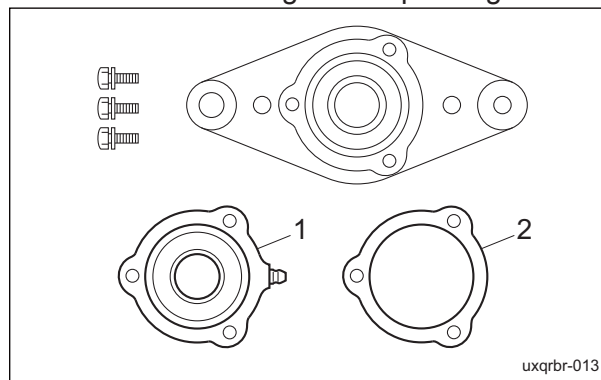

Reel Housing_002

1	Housing lid
2	Packing

5. Remove the oil seal from the housing lid.

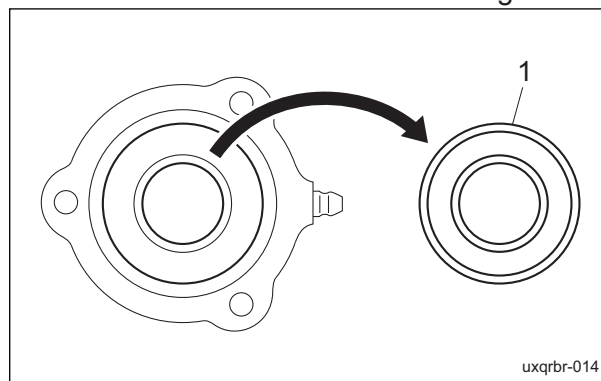

Reel Housing_003

Operating Machine and Mower Units

1	Oil seal
---	----------

6. Remove the bearing of the reel housing.

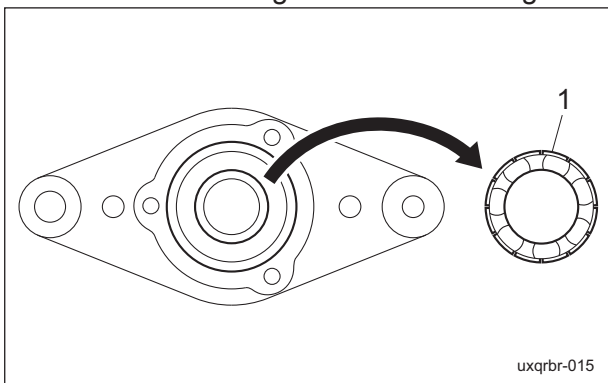

1	Bearing
---	---------

Important

The grease nipple of the reel housing has a specific installation direction. Install it in the correct orientation.

- 10. Install the packing and housing lid to the reel housing with bolts and spring washers.
- 11. Install the grease nipple.
- 12. Install the reel housing.

Important

Be sure to replace the bearing, oil seal and packing with new ones.

- 7. Apply a profuse amount of grease on new bearings and oil seals.
Apply a profuse amount of grease to the lip of the oil seal.

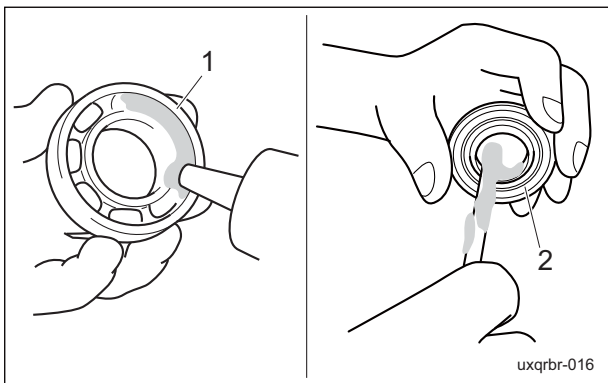

1	Bearing
2	Oil seal

Important

The bearing and oil seal have a specific installation orientation. Install it in the correct orientation.

- 8. Drive the bearing into the reel housing evenly.
- 9. Tap the oil seal into the housing lid evenly.
Note:
Use a bearing driver to drive in the bearings and oil seals.

Operating Machine and Mower Units

Hydraulic Motor Housing

Wear of bearings due to frequent use and/or damage of bearings, etc. caused by invasion of water may prevent smooth rotation of the reel cutter.

Inspect and replace the parts such as the oil seal and bearings.

- Make sure that the hydraulic motor housing does not have any crack.
- Make sure that the spindle bolt and housing bolt receptacles are not shaky.
- Make sure that the bearing receptacle is not shaky.

⚠ Caution

Both the reel cutter (cutting cylinder) and the bed knife (bottom blade) are edged tools. Handle them carefully, since they could cut your hands and feet.

⚠ Caution

"Tightening torques" (Page 3-5) See the list. Note that the Baroness product warranty may not apply to defects caused by incorrect tightening, etc.

Important

The stop ring has a specific installation orientation. Confirm its direction.

Important

The bearing and oil seal have a specific installation orientation. Confirm its direction.

Important

The grease nipple of the hydraulic motor housing has a specific installation orientation. Confirm its direction.

1. Remove the hydraulic motor housing from the reel cutter.
"Removal of Reel Cutter" (Page 4-19)
2. Remove the grease nipple.

3. Remove the stop ring, oil seal, and bearing in order.

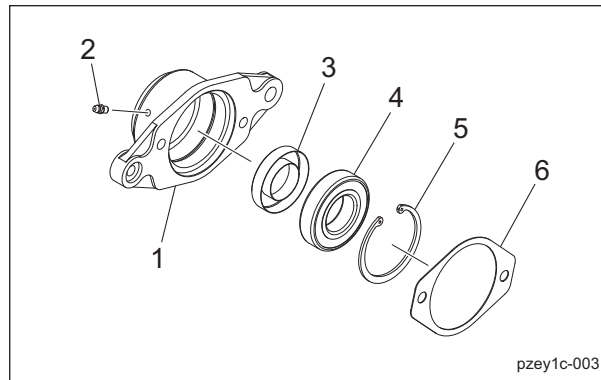

Hydraulic Motor Housing_001

1	Hydraulic motor housing
2	Grease nipple
3	Oil seal
4	Bearing
5	Stop ring
6	Packing

Important

Be sure to replace the bearing and oil seal with new ones.

4. Apply a profuse amount of grease on new bearings and oil seals.
Apply a profuse amount of grease to the lip of the oil seal.

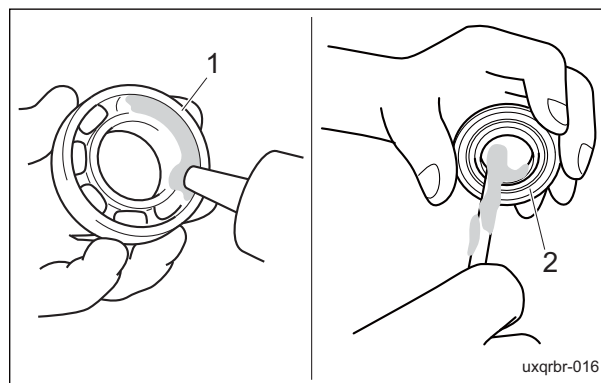

Hydraulic Motor Housing_002

1	Bearing
2	Oil seal

Operating Machine and Mower Units

Important

The bearing and oil seal have a specific installation orientation. Install it in the correct orientation.

Important

The stop ring has a specific installation orientation. Install it in the correct orientation.

Important

The grease nipple of the hydraulic motor housing has a specific installation orientation. Confirm its direction.

5. Drive the bearing into the hydraulic motor housing evenly and install the stop ring.
Note:
Use a bearing driver to drive in the bearing.
6. Tap the oil seal into the hydraulic motor housing evenly.
Note:
Use the bearing driver to drive in the oil seals.
7. Install the grease nipple.
8. Install the hydraulic motor housing.

Bed knife

Replacement of Bed Knife (Bottom Blade)

Caution

Both the reel cutter (cutting cylinder) and the bed knife (bottom blade) are edged tools. Handle them carefully, since they could cut your hands and feet.

Caution

Wear gloves when touching edged tools to avoid cutting your hands.

The criteria for replacing the bed knife (bottom blade) are described below.

1. When the reel cutter (cutting cylinder) is ground
2. When the reel cutter (cutting cylinder) is replaced
3. When the bed knife (bottom blade) is worn
High-speed-steel-tipped blade
Replace the bed knife (bottom blade) before it no longer has a tip.

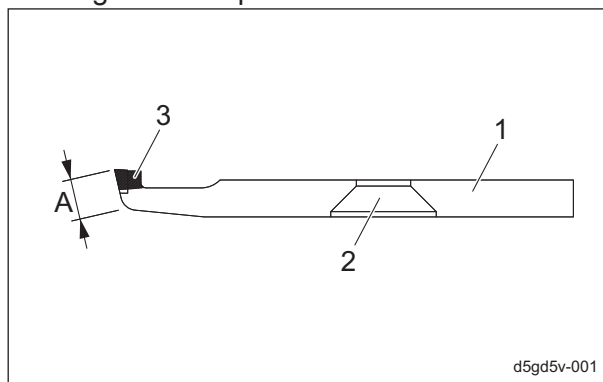

Replacement of Bed Knife (Bottom Blade)_001

1	Bed knife (bottom blade)
2	Mounting hole
3	Tip
A	Front face

Operating Machine and Mower Units

Roller

Front Roller

Wear of bearings due to frequent use and/or damage of bearing, etc. caused by invasion of water may prevent smooth rotation of the roller.

Inspect and replace the parts such as the oil seal and bearings.

- Make sure that there is no abrasion or adhesion of the roller.
- Make sure that there is no abrasion of the collars nor nuts on both ends.
- Make sure that there is no wear or rust of the bearing or play of the housing or bearing.

⚠ Danger

Both the reel cutter (cutting cylinder) and the bed knife (bottom blade) are edged tools. Handle them carefully, since they could cut your hands and feet.

⚠ Caution

"Tightening torques" (Page 3-5) See the list. Note that the Baroness product warranty may not apply to defects caused by incorrect or overtorque tightening, etc.

1. Remove the front roller assy.
2. Follow the steps below to disassemble the front roller.

[1] Use the special wrench to loose the roller housing and nuts of one side, and remove the roller housing.

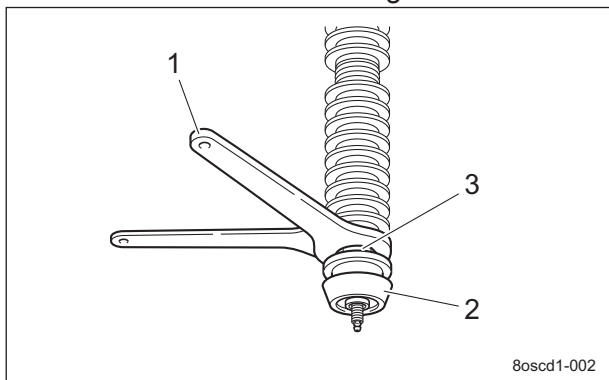

Front Roller_001

1	Special wrench
2	Roller housing
3	Nut

[2] Pull out the roller shaft, and then remove the plate and nut.

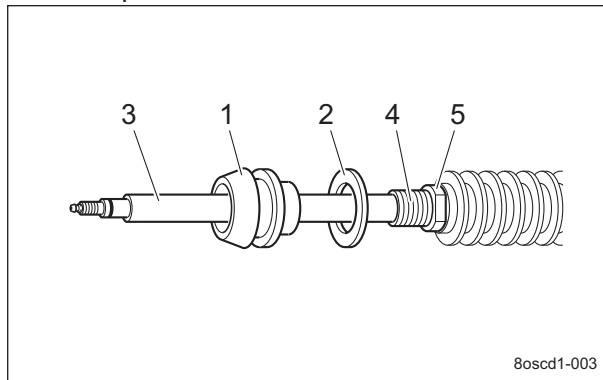

Front Roller_002

1	Roller housing
2	Plate
3	Roller shaft
4	Roller pipe
5	Nut

[3] Remove the rollers, adjustment washers, and spring from the roller pipe.

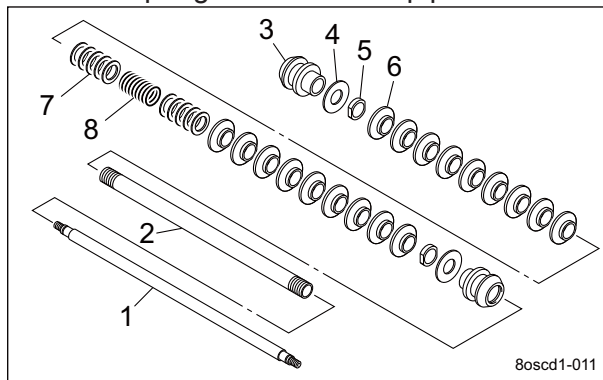

Front Roller_003

1	Roller shaft
2	Roller pipe
3	Roller housing
4	Plate
5	Nut
6	Roller
7	Adjustment washer
8	Spring

Operating Machine and Mower Units

[4] Use the special wrench to loose the roller housing and nut on the other side, and remove the roller housing, plate, and nut from the roller pipe.

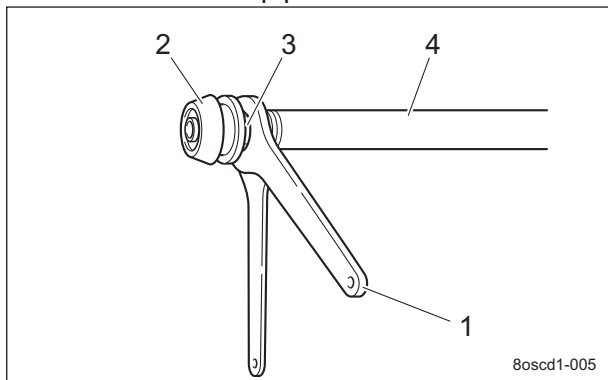

Front Roller_004

1	Special wrench
2	Roller housing
3	Nut
4	Roller pipe

Note:
When disassembling the roller pipe, only the nut may be loosen and the roller housing and roller pipe may not be loosen.
In such a case, lock the nut and roller housing of the other side with the special wrench, and loose the roller housing.

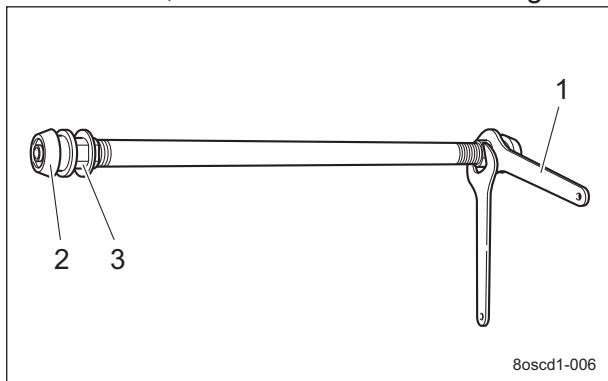

Front Roller_005

1	Special wrench
2	Roller housing
3	Nut

[5] Remove stop ring A, collar, O-ring, oil seal A, bearing, oil seal B, and stop ring B from the roller housing.

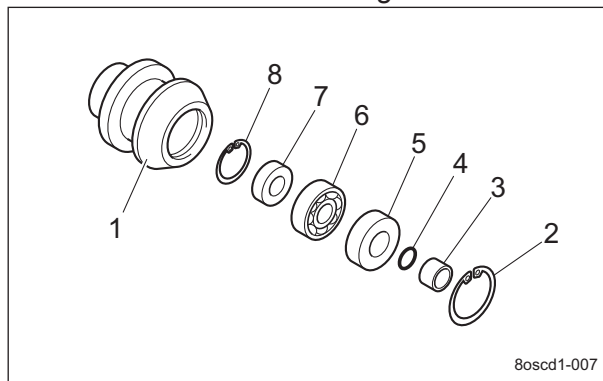

Front Roller_006

1	Roller housing
2	Stop ring A
3	Collar
4	O-ring
5	Oil seal A
6	Bearing
7	Oil seal B
8	Stop ring B

Important

Be sure to replace the bearing, oil seal, and O-ring with new ones.

3. Apply a profuse amount of grease on new bearings and oil seals.
For bearings, apply the grease until it overflows from the opposite side.
Apply a profuse amount of grease to the lip of the oil seal.

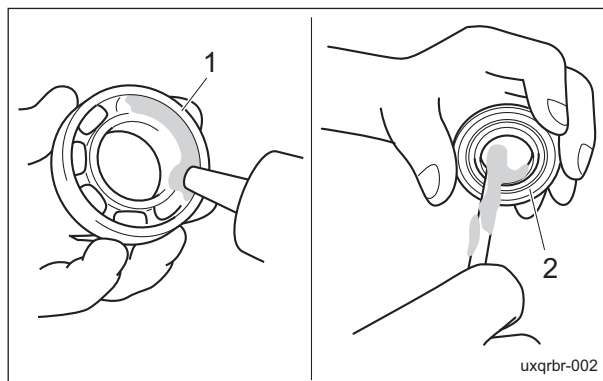

Front Roller_007

1	Bearing
2	Oil seal

Operating Machine and Mower Units

4. Follow the steps below to assemble the front roller.

Important

The stop ring has a specific installation orientation. Install it in the correct orientation.

[1] Install stop ring B, oil seal B, bearing, oil seal A, O-ring, collar, and stop ring A onto the roller housing.

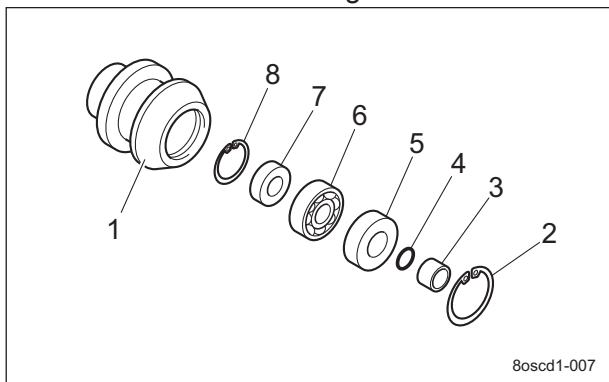

Front Roller_008

1	Roller housing
2	Stop ring A
3	Collar
4	O-ring
5	Oil seal A
6	Bearing
7	Oil seal B
8	Stop ring B

Important

The roller housing to be installed first must be pushed all the way into the roller pipe.

[2] Install the nut, plate, and roller housing in order onto one side of the roller pipe, and lock them with a nut.

[3] Install the roller shaft, rollers, adjustment washers, and spring onto the roller pipe.

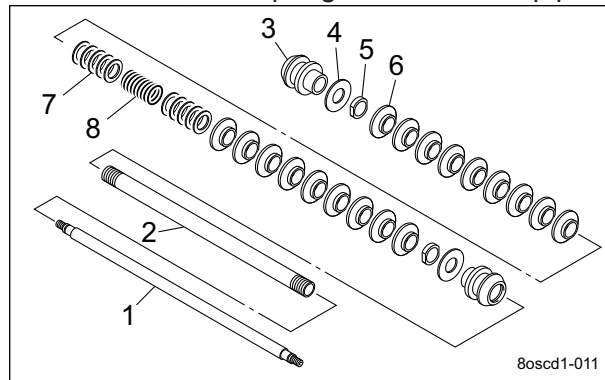

Front Roller_009

1	Roller shaft
2	Roller pipe
3	Roller housing
4	Plate
5	Nut
6	Roller
7	Adjustment washer
8	Spring

[4] Install the nuts and tighten them to the maximum extent.

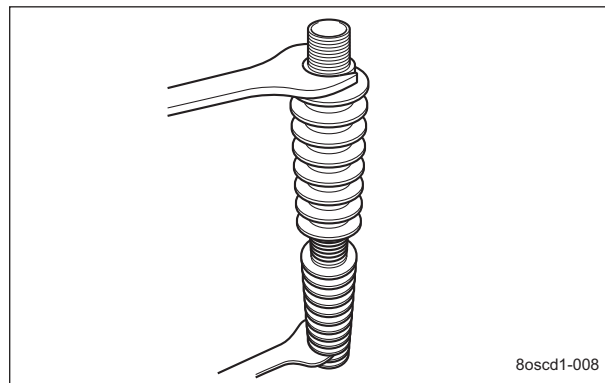

Front Roller_010

[5] Install the plate to the roller pipe.

[6] Tighten the roller housing to the roller pipe.

Operating Machine and Mower Units

[7] Secure the roller housing with nut.

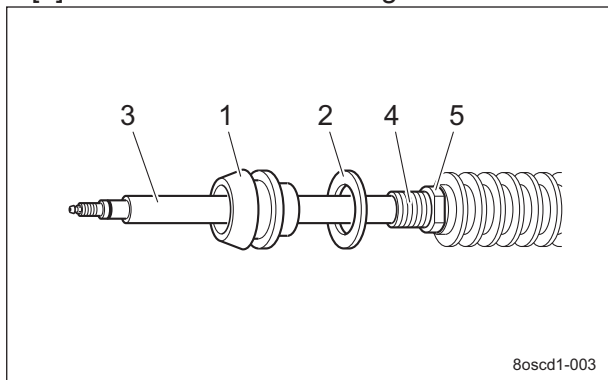

Front Roller_011

1	Roller housing
2	Plate
3	Roller shaft
4	Roller pipe
5	Nut

5. Check the total length of the front roller assy.

26-inch specification	696.0 mm (27.40 in)
22-inch specification	593.5 mm (23.36 in)

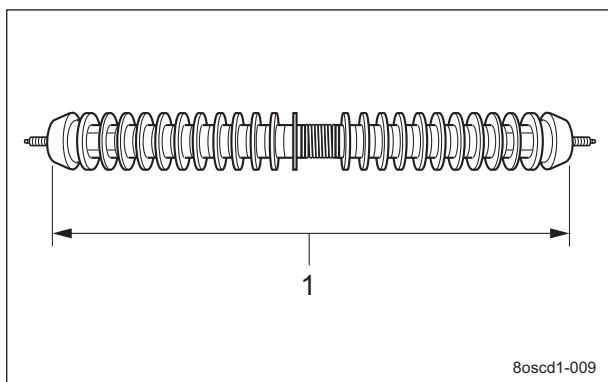

Front Roller_012

1	Total length
---	--------------

Note:

If the total length is longer than the standard dimension, the tightening of the roller housing is insufficient.

6. Make sure that the roller rotates smoothly with no play when the roller shaft is fixed.

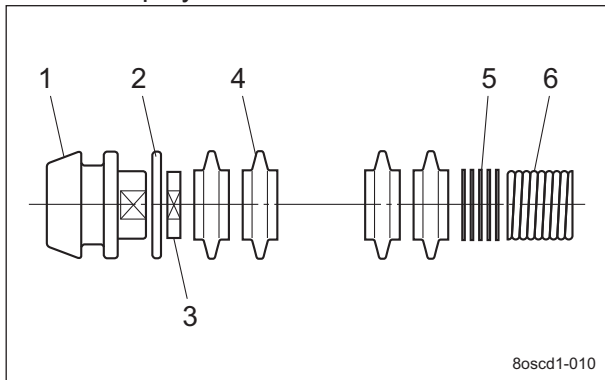

Front Roller_013

1	Roller housing
2	Plate
3	Nut
4	Roller
5	Adjustment washer
6	Spring

Note:

If the roller does not rotate, the spring has play, or the roller has a backlash, adjust the clearance of the spring with the adjustment washers.

When the roller is pushed toward the spring, the clearance of the spring is 1.0 to 3.0 mm (0.039 to 0.118 in).

7. Apply grease.

8. Install the front roller assy.

"Installation of Front Roller Assy" (Page 4-26)

Operating Machine and Mower Units

Rear Roller

Wear of bearings due to frequent use and/or damage of bearing, etc. caused by invasion of water may prevent smooth rotation of the roller.

Inspect and replace the parts such as the oil seal and bearings.

- Make sure that there is no abrasion or adhesion of the rear roller.
- Make sure that there is no abrasion of the collars nor nuts on both ends.
- Make sure that there is no wear or rust of the bearing or play of the housing or bearing.

⚠ Caution

Both the reel cutter (cutting cylinder) and the bed knife (bottom blade) are edged tools. Handle them carefully, since they could cut your hands and feet.

⚠ Caution

"Tightening torques" (Page 3-5) See the list. Note that the Baroness product warranty may not apply to defects caused by incorrect tightening, etc.

1. Remove the rear roller assy.
"Removal of the Rear Roller Assy" (Page 4-26)
2. Remove the three bolts and spring washers used to install the seal housing.

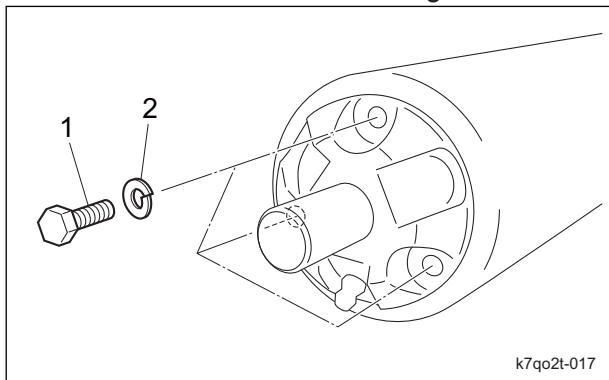

Rear Roller_001

1	Bolt
2	Spring washer

3. Knock one end of the roller shaft with a plastic hammer to push out the shaft.

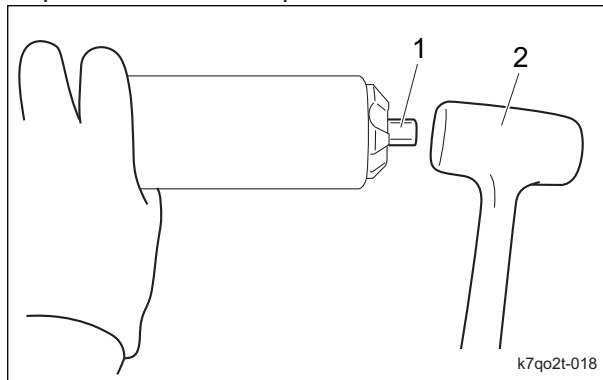

Rear Roller_002

1	Roller shaft
2	Plastic hammer

4. Remove the seal housing, packing, and bearing on either end.
5. Remove the oil seal from the seal housing.
6. Follow the same steps to remove them from the other side.
7. Remove the roller shaft.

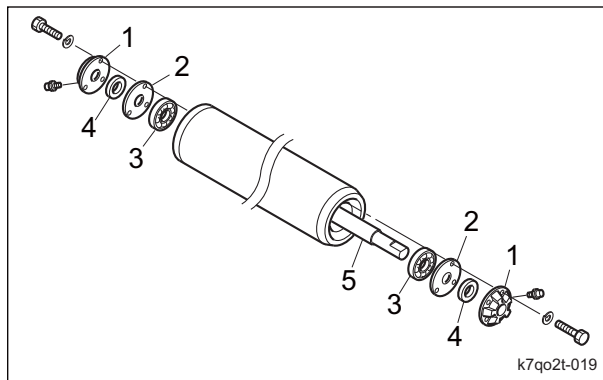

Rear Roller_003

1	Seal housing
2	Packing
3	Bearing
4	Oil seal
5	Roller shaft

Operating Machine and Mower Units

Important

Be sure to replace the bearing and oil seal with new ones.

- Apply a profuse amount of grease on new bearings and oil seals.
For bearings, apply the grease until it overflows from the opposite side.
Apply a profuse amount of grease to the lip of the oil seal.

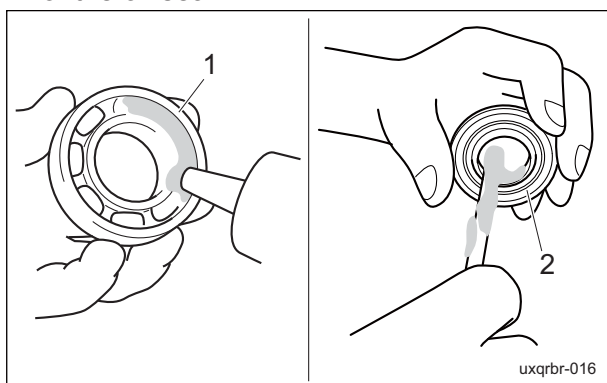

Rear Roller_004

1	Bearing
2	Oil seal

- Install the rear roller assy following the reversed procedure of the procedure 2. to 7.
- Make sure that the roller rotates smoothly with no play when the roller shaft is fixed.
- Apply grease.
- Install the rear roller assy to the mower unit.
"Installation of Rear Roller Assy" (Page 4-27)

CR Brush Assy

Note:

Depending on the specifications, this function may not be available.

Wear of bearings due to frequent use and/or damage of bearing, etc. caused by invasion of water may prevent smooth rotation of the CR brush.

Inspect and replace the parts such as the oil seal and bearings.

- Check that there is no deformation or damage on the brush.
- Make sure that the brush shaft is not bent nor worn.
- Make sure that the brush frame and brush housing do not have any cracks.

- Make sure that the bearing receptacles of the brush frame and brush housing have no play.
- Make sure that there is no wear or damage of the belt.

Caution

"Tightening torques" (Page 3-5) See the list.
Note that the Baroness product warranty may not apply to defects caused by incorrect or overtightening, etc.

- Loosen the tension pulley shaft applying tension to the belt, and remove the belt.

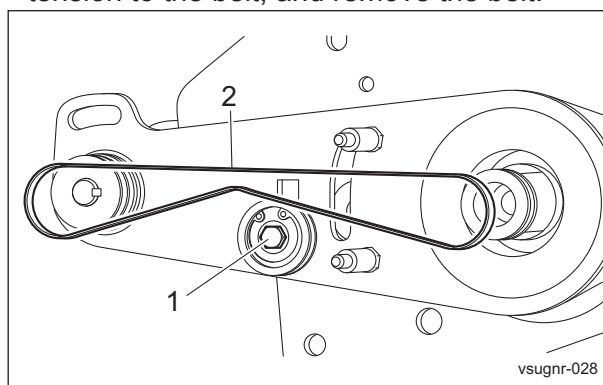

CR Brush Assy_001

1	Tension pulley shaft
2	Belt

- Remove the CR brush assy.
"Removal of CR Brush Assy" (Page 4-28)
- Remove the brush pulley hollow screws.

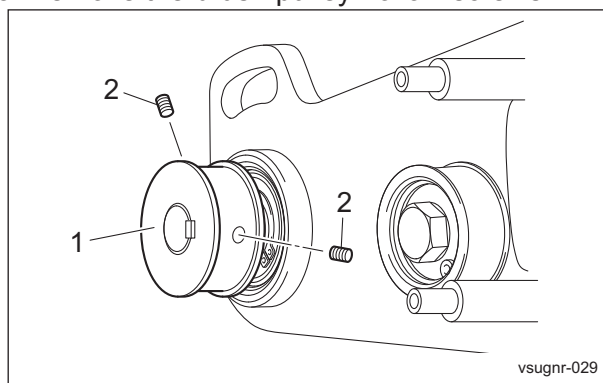

CR Brush Assy_002

1	Brush pulley
2	Hollow screw

Operating Machine and Mower Units

4. Remove the brush pulley from the brush shaft.

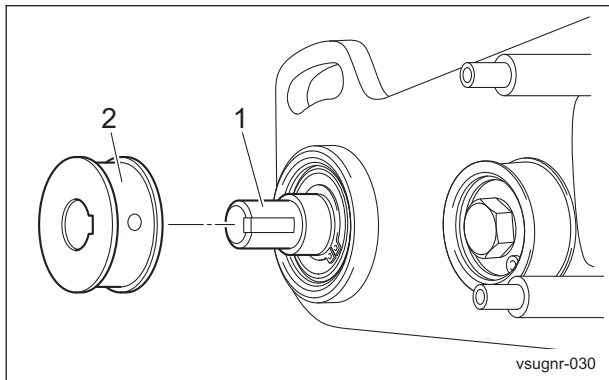

CR Brush Assy_003

1	Brush shaft
2	Brush pulley

5. Remove the key from the brush shaft.

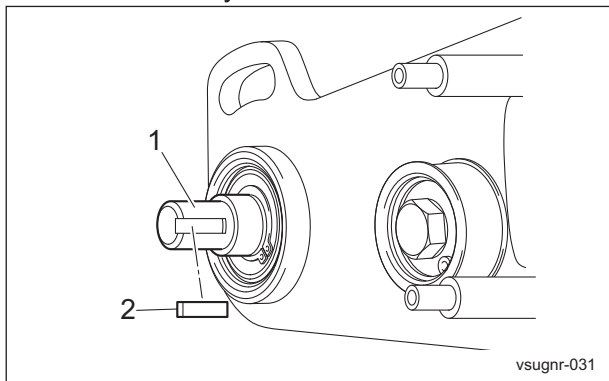

CR Brush Assy_004

1	Brush shaft
2	Key

6. Remove the stop ring from the brush shaft.

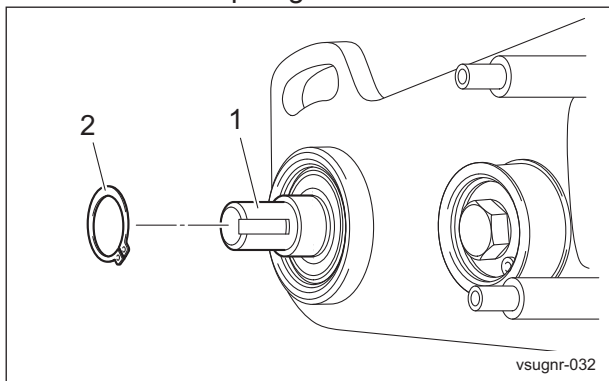

CR Brush Assy_005

1	Brush shaft
2	Stop ring

7. Tap the end of the brush shaft with a plastic hammer or similar tool, and remove it from the brush frame.

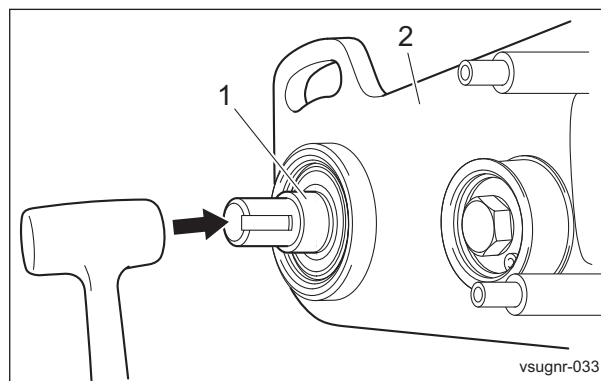

CR Brush Assy_006

1	Brush shaft
2	Brush frame

8. Follow the steps below to disassemble the brush frame.

[1] Remove the stop ring from the brush frame.

[2] Remove the bearing.

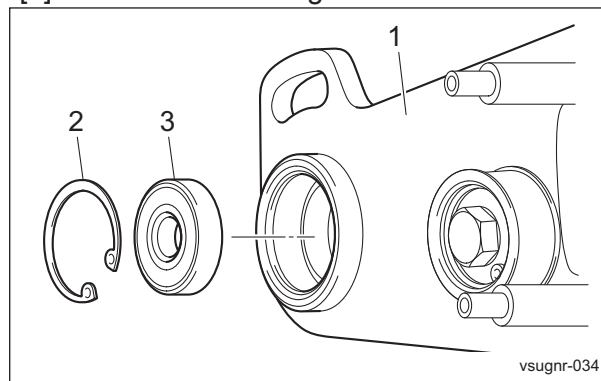

CR Brush Assy_007

1	Brush frame
2	Stop ring
3	Bearing

[3] Loosen the tension pulley shaft, and remove it from the screw washer.

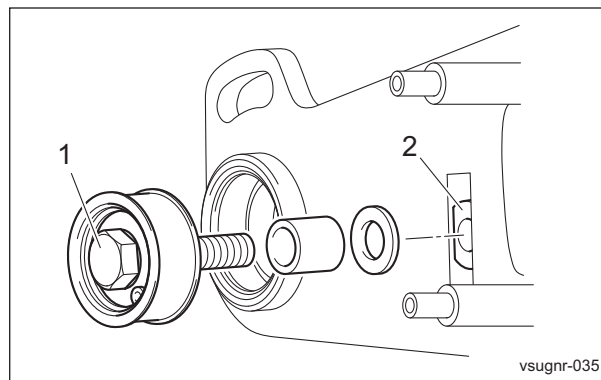

CR Brush Assy_008

Operating Machine and Mower Units

1	Tension pulley shaft
2	Screw washer

[4] Tap the end of the tension pulley shaft with a plastic hammer or similar tool, and remove it from the tension pulley.

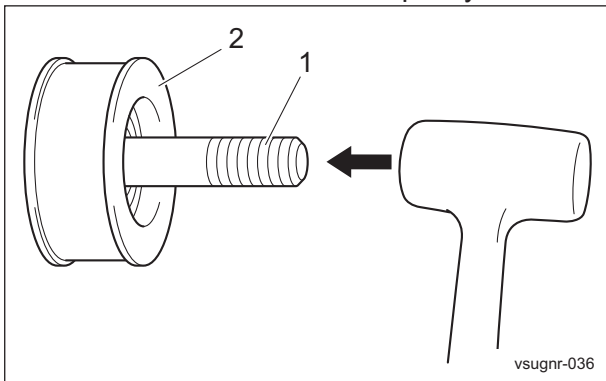

CR Brush Assy_009

1	Tension pulley shaft
2	Tension pulley

[5] Remove the stop ring from the tension pulley.

[6] Remove the bearing.

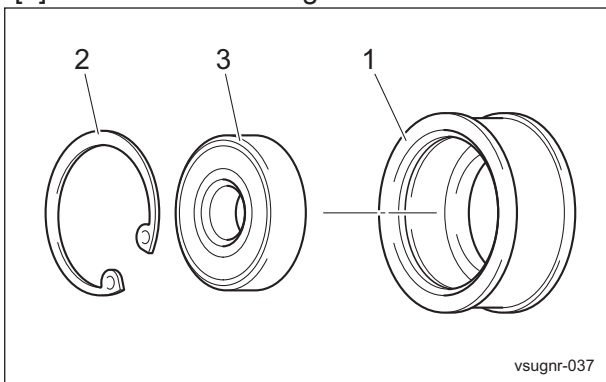

CR Brush Assy_010

1	Tension pulley
2	Stop ring
3	Bearing

[7] Remove the O-ring and oil seal from the brush frame.

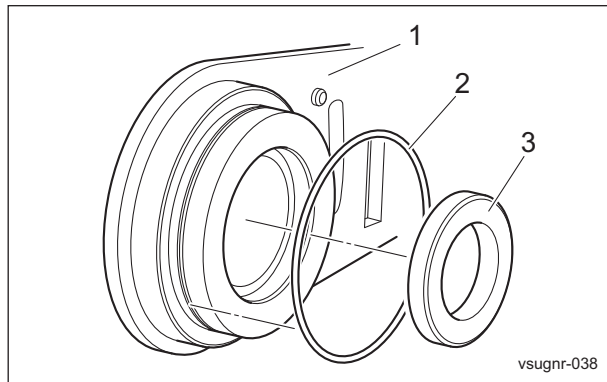

CR Brush Assy_011

1	Brush frame
2	O-ring
3	Oil seal

9. Tap the end of the brush shaft with a plastic hammer or similar tool, and remove it from the brush shaft housing.

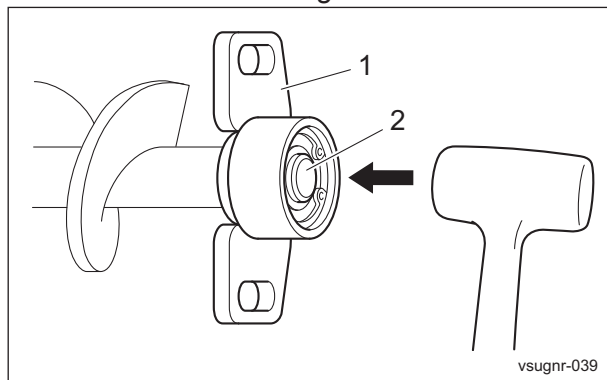

CR Brush Assy_012

1	Brush shaft housing
2	Brush shaft

10. Follow the steps below to disassemble the brush shaft housing.

[1] Remove the stop ring from the brush shaft housing.

[2] Remove the bearing.

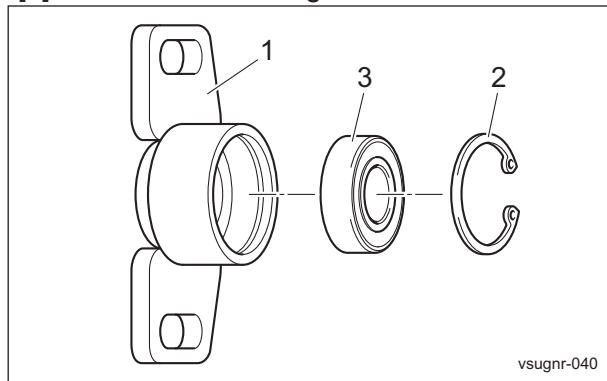

CR Brush Assy_013

Operating Machine and Mower Units

1	Brush shaft housing
2	Stop ring
3	Bearing

2. Apply grease to the end of the brush shaft, and install the brush shaft to the brush shaft housing.

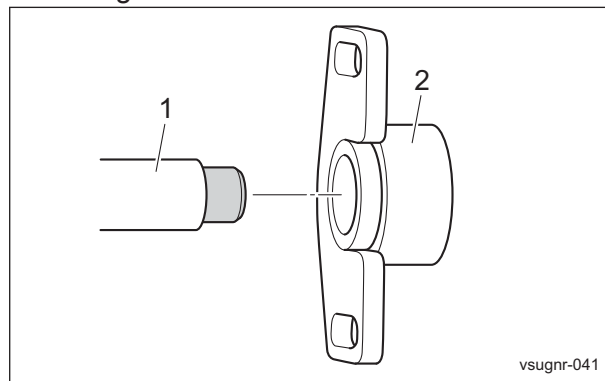

CR Brush Assy_015

1	Brush shaft
2	Brush shaft housing

Important

Replace deteriorated, deformed, or worn parts with new ones.

Important

Be careful not to cause damage or deformation to the brush.

Important

Be sure to replace the bearing and O-ring with a new ones.

Important

The stop ring has a specific installation orientation. Install it in the correct orientation.

For installation, reverse the disassembly steps.

1. Follow the steps below to assemble the brush shaft housing.

[1] Install the brush shaft housing bearing.

Note:

Use a bearing driver to drive in the bearing.

[2] Attach the stop ring.

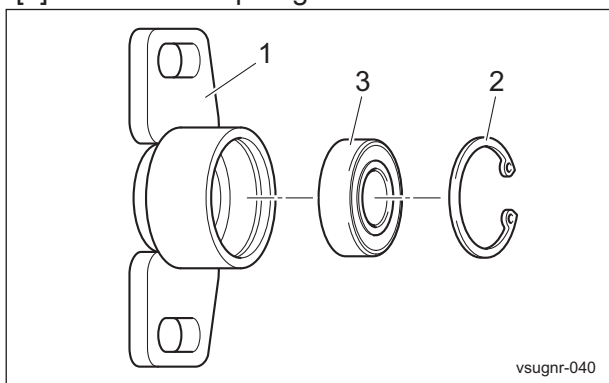

CR Brush Assy_014

1	Brush shaft housing
2	Stop ring
3	Bearing

3. Follow the steps below to install the housing frame.

[1] Install the bearing to the tension pulley.

Note:

Use a bearing driver to drive in the bearing.

[2] Attach the stop ring.

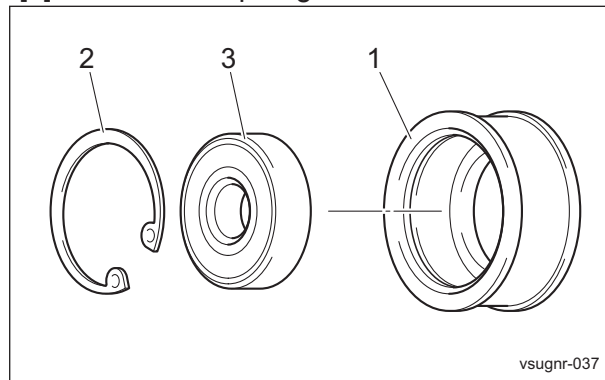

CR Brush Assy_016

1	Tension pulley
2	Stop ring
3	Bearing

Operating Machine and Mower Units

[3] Apply grease to the shaft section of the tension pulley shaft, and drive it to the tension pulley assy with a plastic hammer or similar tool.

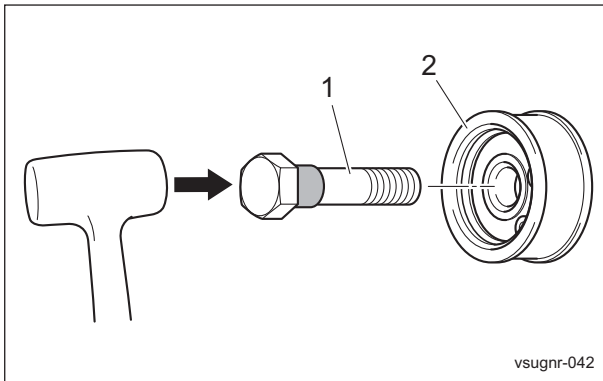

CR Brush Assy_017

1	Tension pulley shaft
2	Tension pulley assy

[4] After inserting the tension pulley assy to the collar and disc spring washer, insert the screw washer into the groove from the opposite side of the brush frame, and temporarily tighten the tension pulley shaft.

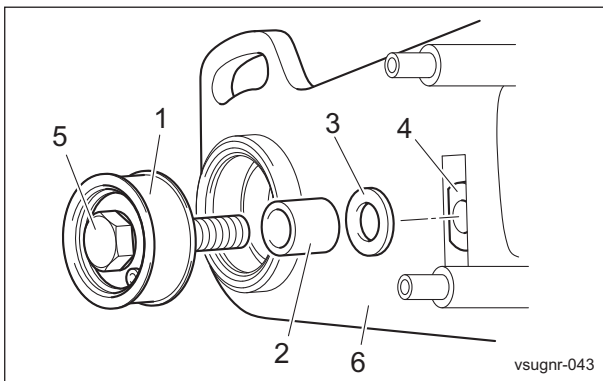

CR Brush Assy_018

1	Tension pulley assy
2	Collar
3	Disc spring washer
4	Screw washer
5	Tension pulley shaft
6	Brush frame

[5] Install the bearing to the brush frame.

[6] Attach the stop ring.

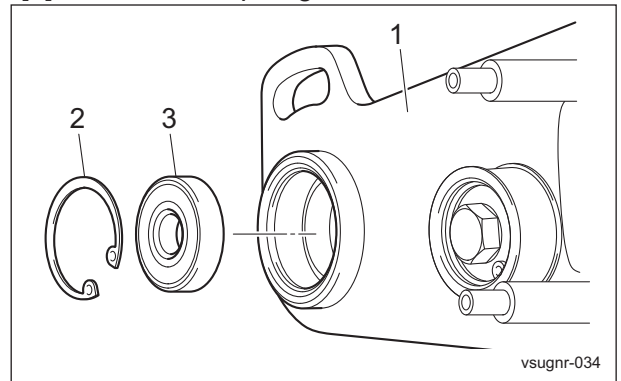

CR Brush Assy_019

1	Brush frame
2	Stop ring
3	Bearing

[7] Apply grease to the shaded section of the brush shaft, tap the other end of the brush shaft with a plastic hammer or similar tool, and install it to the brush frame.

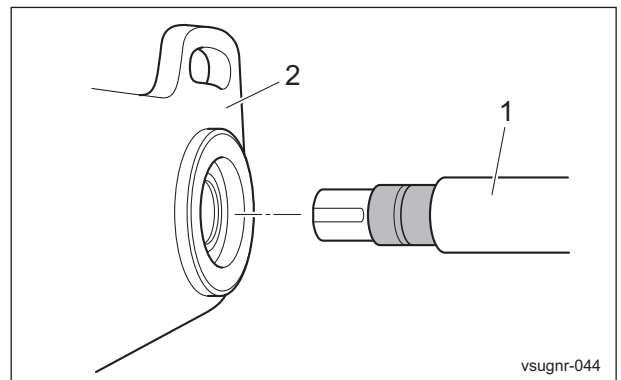

CR Brush Assy_020

1	Brush shaft
2	Brush frame

4. Install the stop ring to the brush shaft groove.

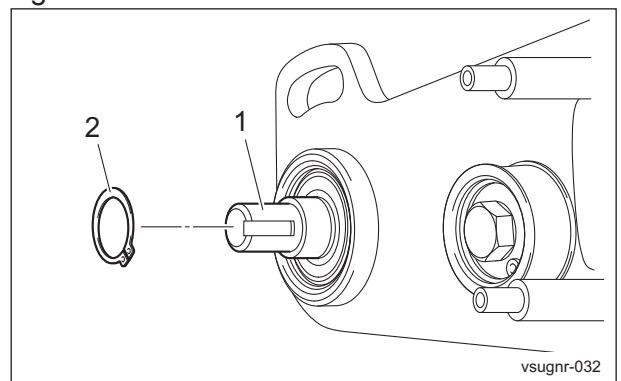

CR Brush Assy_021

1	Brush shaft
2	Stop ring

Operating Machine and Mower Units

5. Install the key to the brush shaft key groove.

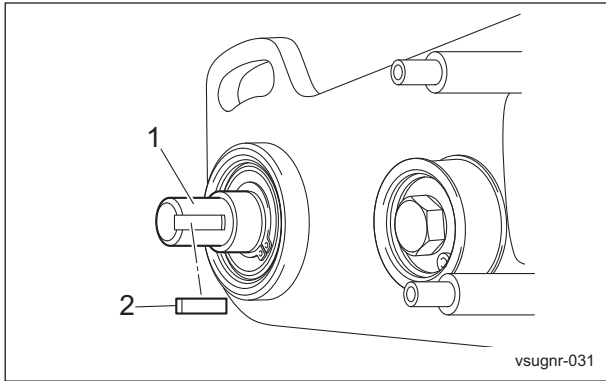

CR Brush Assy_022

1	Brush shaft
2	Key

6. Install the brush pulley by aligning the brush pulley key groove and the brush shaft key.

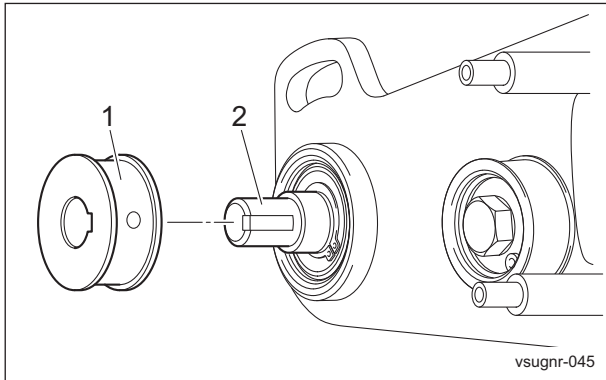

CR Brush Assy_023

1	Brush pulley
2	Brush shaft

7. Install the hollow screws to the brush pulley.

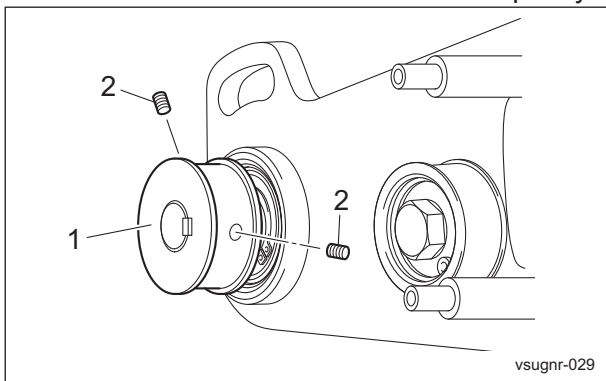

CR Brush Assy_024

1	Brush pulley
2	Hollow screw

Important

For installation of the O-ring and oil seal, apply grease and then install them. Apply grease to the entire O-ring, and to the lip surface of the oil seal.

8. Apply grease to the O-ring and oil seal, and install them to the brush frame.

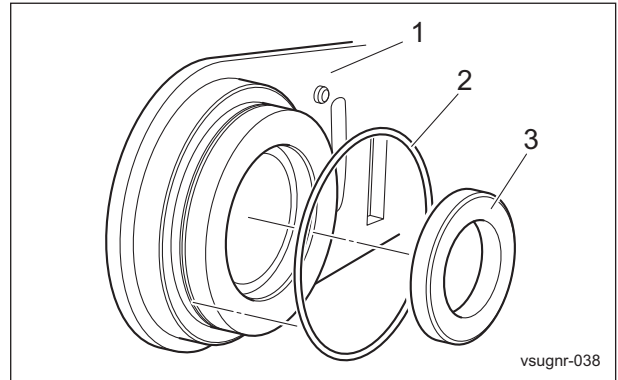

CR Brush Assy_025

1	Brush frame
2	O-ring
3	Oil seal

9. Install the CR brush assy to the mower unit.
 10. Install the belt to the brush pulley and driving pulley.
 11. Adjust the belt tension.

The belt tension is appropriate when there is 5.0 - 6.0 mm (0.197 - 0.236 in) of slack when the belt is pressed lightly by finger at 10.0 N (1.0 kgf) around the center section between the belt pulleys.

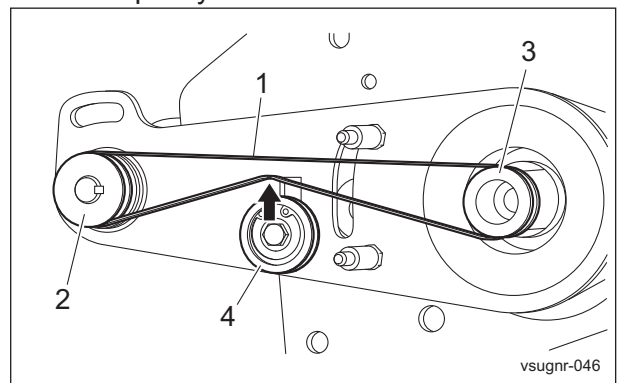

CR Brush Assy_026

1	Belt
2	Brush pulley
3	Driving pulley
4	Tension pulley

**Relating to Operating Machine and
Mower Unit Page 5-2**

Troubleshooting

Relating to Operating Machine and Mower Unit

Problem	Cause	Reference
Blade adjustment gets out of order	Insufficient tension of the spring of the pipe part with the cutter adjustment screw	Operating machine and mower units - Removal and installation of each section - Reel cutter
	Adhesion or play of the up/down movement part of the reel housing	Operating machine and mower units - Inspection and repair of each section - Reel housing - Hydraulic motor housing
	Malfunction of the reel bearing	Operating machine and mower units - Inspection and repair of each section - Reel housing Replacement of the bearing
	Wear of the reel shaft	Operating machine and mower units - Inspection and repair of each section - Reel cutter
	Insufficient tightening of the reel nuts	Operating machine and mower units - Removal and installation of each section - Reel cutter
	Insufficient tightening of the mounting bolts of the bed knife base	Operating machine and mower units - Inspection and repair of each section - Bed knife
Cutting height adjustment gets out of order.	Malfunction of the roller bearing	Operating machine and mower units - Inspection and repair of each section - Roller Replacement of the bearing
	Looseness of the cutting height adjustment nuts	This unit's Owner's Operating Manual
	Abrasion of the roller shaft	Operating machine and mower units - Inspection and repair of each section - Roller Replacement of the roller shaft
Mowed face is not flat	The cutting heights of the mower units are not consistent	This unit's Owner's Operating Manual
	The edge is rounded	Operating machine and mower units - Inspection and repair of each section - Grinding
	The operating speed is too fast.	Operate at an appropriate speed.
Mower units moves irregularly	Malfunction of the roller part	Operating machine and mower units - Inspection and repair of each section - Roller
	The operating speed is too fast.	Operate at an appropriate speed.
The CR brush does not rotate	Insufficient drive belt tension, or severed	Removal and installation of each section - Adjustment - CR brush assy Replacement of the drive belt
	The brush contacts the roller with too strong pressure	Removal and installation of each section - Adjustment - CR brush assy
	Faulty CR brush	Removal and installation of each section - Adjustment - CR brush assy Replacement of the CR brush assy
	Malfunction of bearing	Removal and installation of each section - Adjustment - CR brush assy Replacement of the CR brush assy
Clippings do not enter the grass catcher smoothly	Insufficient adjustment of the reel cover	This unit's Owner's Operating Manual
	Insufficient rotation of the reel cutter	This unit's Owner's Operating Manual

Troubleshooting

Problem	Cause	Reference
Clippings do not enter the grass catcher smoothly	Wrong installation of the grass catcher	This unit's Owner's Operating Manual

Troubleshooting

Specifications list Page 6-2

LS62 Page 6-2

LS66 Page 6-2

Maintenance Schedule Page 6-3

Reference

Specifications list

LS62

Model		LS62			
Type		Base unit (incl. one weight)		With CR brush	
Dimensions	Total length	16.54 in	420 mm	16.54 in	420 mm
	Total width	29.72 in	755 mm	30.55 in	776 mm
	Total height	9.17 in	233 mm	9.17 in	233 mm
Weight	Mower Unit	110.23 lb	50.0 kg	110.23 lb	52.0 kg
	Weight (one piece)	4.41 lb	2.0 kg	—	—
	CR brush	—	—	11.02 lb	5.0 kg
Operating height (Mowing height)		0.394 - 1.811 in	10.0 - 46.0 mm	0.394 - 1.811 in	10.0 - 46.0 mm
Operating width (Mowing width)		22 in	557.5 mm	22 in	557.5 mm
Diameter of the reel cutter		6.4 in	163 mm	6.4 in	163 mm
Blades		9		9	

LS66

Model		LS66			
Type		Base unit (incl. one weight)		With CR brush	
Dimensions	Total length	16.54 in	420 mm	16.54 in	420 mm
	Total width	33.74 in	857 mm	34.61 in	879 mm
	Total height	9.17 in	233 mm	9.17 in	233 mm
Weight	Mower Unit	116.84 lb	53.0 kg	123.46 lb	56.0 kg
	Weight (one piece)	4.41 lb	2.0 kg	—	—
	CR brush	—	—	11.02 lb	5.0 kg
Operating height (Mowing height)		0.394 - 1.811 in	10.0 - 46.0 mm	0.394 - 1.811 in	10.0 - 46.0 mm
Operating width (Mowing width)		26 in	660 mm	26 in	660 mm
Diameter of the reel cutter		6.4 in	163 mm	6.4 in	163 mm
Blades		5 • 7 • 9		5 • 7 • 9	

Maintenance Schedule

LS62 • LS66

Follow the maintenance schedule below.

○ • • • Inspect, adjust, supply, clean

● • • • Replace (first time)

△ • • • Replace

Maintenance Item	Before Work	After Work	Every 10 hrs.	Every 50 hrs.	Every 250 hrs.	Every 500 hrs.	When Required	Remarks
Check blade condition (Reel cutter and Bed knife)	○							Refer to "Inspection of Reel Cutter (Cutting Cylinder) and Bed Knife (Bottom Blade)"
Check cover condition	○							Refer to "Inspection of Covers"
Check roller condition	○							Refer to "Inspection of Roller"
Check CR brush condition	○							Refer to "Inspection of CR Brush"
Check scraper condition	○							Refer to "Inspection of Scraper"
Check belt condition	○							Refer to "Inspection of Belt"
Check damaged parts	○							
Check tightening bolts and nuts	○							
Engage blades	○							Refer to "Adjustment of Blade Engagement"
Check mowing height	○							Refer to "Adjustment of Cutting Height"
Adjust reel cover (Variable type)	○							Refer to "Adjustment of Reel Cover (Variable Type)"
Adjust CR brush	○							Refer to "Adjustment of CR Brush"
Adjust scraper	○							Refer to "Adjustment of Scraper"
Clean mower unit		○						Refer to "Cleaning of Mower Unit"
Backlap blades							○	Refer to "Back Lapping of Reel Cutter (Cutting Cylinder)"
Grease				○				Refer to "Greasing Points"
Clean inside of CR brush belt cover				○				
Grease hydraulic motor shaft of mower unit					○			Refer to "Greasing Points"
Grease spindle bolt of reel housing						○		
Adjust cutter adjustment spring							○	Refer to "Adjustment of Cutter Adjustment Spring"
Adjust belt tension of CR brush							○	Refer to "CR Brush Drive Belt"
Regrind blades (Reel cutter and Bed knife)							○	Regrind/Replace blades as and when required

• The values for consumables are not guaranteed.

Reference

BARONESS[®]
Quality on Demand

 **KYOEISHA CO., LTD.**
Head Office 1-26, Miyuki-cho, Toyokawa, Tel : (0533) 84-1390
Aichi-Pref. 442-8530 Japan. Fax : (0533) 89-3623