

RR1000

Riding Roller

Service manual

BARONESS[®]
Quality on Demand

RR1000 MAINTENANCE

Contents

1)	Fastening torque	2
2)	Engine	2
3)	Hydrostatic Pump Motor (HST)	2
4)	Coupling	2
5)	REF. NO. 41 CODE 801699628 TIMING BELT tension setting	4
6)	REF. NO. 101 CODE 801699635 CHAIN tension setting	4
7)	WIRE ASSEMBLY REF. NO. 59 CODE 801709159 / REF. NO. 60 CODE 801709160 adjustment method	4
8)	REF. NO. 74 CODE 801699683 SPRING adjustment alteration	4
9)	Roller (steering) steering ring replacement	5
10)	REF. NO. 21 CODE 801699617 HYDROSTATIC PUMP MOTOR (HST) replacement	6
11)	REF. NO. 156 CODE 801709062 LINK ARM fastening position correction or replacement	8
12)	REF. NO. 135 CODE 801699658 LINK ARM fastening position correction or replacement	8
13)	REF. NO. 132 CODE 801699657 GUIDE replacement	9
14)	REF. NO. 173 CODE 801706973 BRACKET replacement	10
15)	REF. NO. 214 CODE 801709087 BRACKET slide adjustment	11
16)	REF. NO. 324 CODE 801706816 FASTENER fastening force adjustment	11
17)	For other locations, disassembly or part replacement	11

1) Fastening torque

Fastening torque for pertinent parts is given in the table. The torque values correspond to the REF. NO. of the parts list, and are provided for required parts only. The table provides torque value only; torque values are not provided for common bolts and adjustment bolts.

See attached Table 1.

2) Engine

Basic information concerning engine handling and operation shall be as given in the SUBARU EX Series instructions manual.

Oil volume: 0.6 L (SAE 10-30W or equivalent)

Oil replacement method has already been recorded on P. 19 of the RR1000 instructions manual.

Preset speed shall be 3000 min^{-1} for the high speed side (matches HST upper limit speed) and 1600 min^{-1} for the low speed side; upper/lower limit positions of the speed control lever shall be regulated by bolt contact position. Speed shall be set by tachometer when adjusting.

3) Hydrostatic Pump Motor (HST)

Oil level shall be within the specified oil level range provided on the side of the tank at the top of the HST. Already given on P. 10 of RR1000 instructions manual

Oil 10W-30 CD class (HST maker specified)Already given on P. 19 of RR1000 instructions manual

Life: 300 hrs (HST maker preset value)

Components shall not be provided for HST. REF. NO. 21 CODE 801699617 only shall be provided.

Oil replacement shall be as described in the following 10) HST (Hydrostatic Pump Motor), thus enabling individual HST.

4) Coupling

The tolerance for coupling is as follows:

Allowable parallel error: Within 1.0mm; Allowable angle error: Within 2°; Axial displacement: Within $\pm 4\text{mm}$ (Coupling manufacturer specified value)

Max. allowable speed 6500 min^{-1} ; Common torque value $120\text{N} \cdot \text{m}$
(comparison engine max. torque $13.9\text{N} \cdot \text{m} / 2500 \text{ min}^{-1}$)

Reuse of REF. NO. 14 CODE 801707788 CAP BOLT is forbidden when replacing parts in this location.

This is to prevent parts of rotating parts from falling out. Bolts applied with anaerobic adhesive are employed; reuse is forbidden to ensure safety.

Part REF.NO.13 CODE 801707787 COUPLING replacement procedure

(1) Open Ref No. 316 CODE 801709071 BELT COVER to the rear.

- (2) Remove REF. NO. 9 CODE 801682497 BOLT and remove REF. NO. 8 CODE 801709054 FAN COVER.
- (3) Remove four REF. NO. 801707788 CAP BOLT fastening REF. NO. 13 CODE 801707787 COUPLING from the circumference surface. **Do not reuse bolts that have been removed.**
- (4) Remove the four REF. NO. 7 CODE 801682505 BOLT fastening the engine.
- (5) Move the engine toward its recoil starter side. When doing so, be careful not to apply external force on REF. NO. 5 CODE 801699969 BUSHING mounted to the flange below the engine.
- (6) Remove the four remaining REF. NO. 14 CODE 801707788 CAP BOLT.
Do not reuse bolts that have been removed.
- (7) The new REF. NO. 13 CODE 801707787 COUPLING is attached to REF. NO. 15 CODE 801709158 COUPLING; the pins must however be lined up with the pin holes.
- (8) Fasten with new REF. NO. 14 CODE 801707788 CAP BOLT to 49 to 54N · m of torque.
- (9) Slide the engine back to its original mounting position. Turn the REF. NO. 13 CODE 801707787 COUPLING to line up the mounting screw section of the engine side REF. NO. 12 CODE 801709157 COUPLING with the outer circumference holes.
- (10) Temporarily fasten the four REF. NO. 14 CODE 801707788 CAP BOLT.
- (11) Fasten the engine with four REF. NO. 7 CODE 801682505 BOLT.
- (12) Fasten CAP BOLT of (12) (10) to 49 to 54N · m of torque.
- (13) Prepare the machine for towing, erect the stand and move the roller up from the ground surface.
- (14) Move the stop switch of the engine to the stop "O" side.
- (15) Pull the start knob of the recoil starter out slowly and check if the HST shaft rotates without resistance.
- (16) Move the stop switch of the engine to the run "I" side and start in accordance with the start procedure.
- (17) Set motor speed near idle and check if there is any abnormal vibration or noise.
Do not operate pedals while checking.
- (18) Raise the speed setting gradually and check in the same manner. Ultimately raise to maximum speed and check.
- (19) If no abnormal vibration or noise is noted, lower speed to idle, press the right and left pedals alternately to make sure pedal operation is properly conveyed to ROLLER (Drive).
Absolutely do not board the device when doing so.
- (20) Similarly, raise the speed setting and continue to check. Ultimately raise to maximum speed and check.
- (21) Return the pedal to the neutral position.
- (22) Make sure the ROLLER (Drive) stops rotating. (The roller may continue to rotate slightly even when the pedals are in the neutral position.)
- (23) Return the engine speed control lever to the idle position.
- (24) Move the stop switch of the engine to the stop "O" side.
- (25) Shut the fuel cock of the engine.

REF. NO. 13 CODE 801707787 COUPLING precautions

- (1) Service ambient temperature: -30° to $+85^{\circ}$
- (2) Using in direct sunlight reduces product life.
- (3) Any grease adhering must be removed with alcohol or acetone.

5) REF. NO. 41 CODE 801699628 TIMING BELT tension setting

Already given on P. 21 of RR1000 instructions manual.

Reference: The probability of having to replace this belt is low. Make sure the shafts are parallel to each other (parallelism: 1/400) when adjusting tension.

6) REF. NO. 101 CODE 801699635 CHAIN tension setting

Already given on P. 22 of RR1000 instructions manual.

Replacement timing for the CHAIN and procedure for shaft position offset of the ROLLER (Drive) when adjusting tension have already been recorded on PP. 22 - 23 of the instructions manual.

7) REF. NO. 59 CODE 801709159 / REF. NO. 60 CODE 801709160 WIRE ASSEMBLY adjustment method

Already given on PP. 21 - 27 of RR1000 instructions manual.

For reference position, see attached Assembly drawing 102.

After adjustment, check if the machine can be moved in the left/right directions and stopped on a flat lawn without any problem.

If there is any difference in the amount of time it takes from drive to stop in the left and right directions, check if REF. NO. 130 CODE 801709162 ARM is perpendicular and if the outer circumference of the REF. NO. 80 CODE 801658604 BALL BEARING is making good contact with the half-moon notch of REF. NO. 61 CODE 801699669 ARM.

If not, the problem may be caused by the setting position of the WIRE ASSEMBLY.

If the assembly position is correct, remedy by altering the setting position of REF. NO. 137 CODE 801699662 BOLT and tension of REF. NO. 136 CODE 801658363 SPRING.

Sliding resistance of the inner wire of the WIRE ASSEMBLY increases along with usage time, resulting in requiring more force for pedal operation, or could result in a difference in the amount of force required to operate the left and right pedals. To remedy, apply oil on the inner wire. Process has already been recorded on P. 20 of RR1000 instructions manual.

8) REF. NO. 74 CODE 801699683 SPRING adjustment alteration

When compression force is applied to the SPRING, the trunnion shaft of the Hydrostatic Pump Motor (HST) is forced back to the neutral position when the pedals are not depressed, and output shaft rotation is stopped.

Stopping suddenly while the machine is traveling on the lawn may however affect the operator and the surface of the lawn. To gradually stop while alleviating this problem, match the setting position of the

REF. NO. 89 CODE 801702245 DAMPER and REF. NO. 73 CODE 801656398 LOCK NUT.

For reference position of the nut, see Fig. 1.

If you want to increase the time it takes to stop while the machine is being driven, loosen NO. 73 CODE 801656398 LOCK NUT.

If you want to decrease the time it takes to stop while the machine is being driven, tighten NO. 73 CODE 801656398 LOCK NUT.

The amount of loosening or tightening must be the same for both the left and right sides. Adjust according to the preference of the operator while driving on a flat lawn.

The proper amount of time to stop the machine while performing must be provided to ensure safe operation and prevent damage to the lawn.

9) Roller (steering) steering ring replacement

The ROLLER (Drive) must be removed when replacing parts in this location.

- (1) Prepare the machine for towing.
- (2) Remove REF. NO. 309 CODE 801656743 SCREW.
- (3) Remove REF. NO. 308 CODE 801709069 SHAFT COVER.
- (4) Remove REF. NO. 125 CODE 801656629 BOLT.
- (5) Draw out Ref No. 124 CODE 801657791 SPACER toward the rear.
- (6) Remove REF. NO. 306 CODE 801656743 SCREW.
- (7) Remove REF. NO. 305 CODE 801709068 STEP COVER.
- (8) Remove REF. NO. 158 CODE 801656583 LOCK NUT. Reference Dimensions: 19mm distance between the parallel sides of a hexagon
- (9) Retain REF. NO. 157 CODE 801708142 BALL LINK JOINT with a rope, etc., to keep it from lowering.
- (10) Loosen screw section of REF. NO. 172 CODE 801708142 BALL LINK JOINT
Reference dimensions: 17mm distance between the parallel sides of a hexagon.
Use a low profile spanner.
- (11) Mount four belts on the machine and lift horizontally.
- (12) Provide a base that is 850mm wide, 1200mm long and 125mm high below the machine.
A stopper to restrict left/right motion of the ROLLER (Drive) (not included) is required.
- (13) Mount the rollers on the base. Mount stoppers to immobilize the ROLLER (Drive) so it can't move left/right on the base. Maintain slight tension on the lifting belt.
- (14) Remove REF. NO. 101 CODE 8011699635 CHAIN.
- (15) Remove REF. NO. 109 CODE 801699640 SPROCKET.
- (16) Remove REF. NO. 105 CODE 801657761 PILLOW BLOCK.
- (17) Lift the machine and move to a place other than where the ROLLER (Drive) is.
- (18) Lift to the working height relative to the bottom of the machine.
Provide a means to prevent the load from falling.
- (19) Remove REF. NO. 167 CODE 800017870 BOLT.

- (20) Remove REF. NO. 166 CODE 801669635 WASHER.
- (21) Remove REF. NO. 163 CODE 801709063 LINK ARM.
- (22) Remove REF. NO. 162 CODE 801708142 BALL LINK JOINT or REF. NO. 168 CODE 801708142 BALL LINK JOINT screw section.
Reference Dimensions: 17mm distance between the parallel sides of a hexagon.
Use a low profile spanner.
- (23) For mounting position of REF. NO. 160 CODE 801708143 BOLT or REF. NO. 170 CODE 801708146 BOLT, see Fig. 2.
- (24) When returning to REF. NO. 163 CODE 801709063 LINK ARM section, degrease the screw section of REF. NO. 162 CODE 801708142 BALL LINK JOINT or REF. NO. 168 CODE 801708142 BALL LINK JOINT, apply Anaerobic Adhesive LOCTITE # 242 and mount.
- (25) Mount the assembled REF. NO. 163 CODE 801709063 LINK ARM on the shaft of the machine.
- (26) Mount REF. NO. 166 CODE 801669635 WASHER.
- (27) Apply Anaerobic Adhesive LOCTITE # 242 to REF. NO. 167 CODE 800017870 BOLT and fasten.
- (28) Subsequently perform the procedure in reverse to return to the original status. For fastening torque, see attached Table 1. For tension setting of REF. NO. 101 CODE 8011699635 CHAIN, see PP. 22 - 23 of RR1000 instructions manual.

10) REF. NO. 21 CODE 801699617 HYDROSTATIC PUMP MOTOR (HST) replacement

- (1) Remove REF. NO. 64 CODE 801668299 CAP BOLT and REF. NO. 65 CODE 801707800 CONICAL SPRING WASHER fastening the WIRE ASSEMBLY.
- (2) Draw out REF. NO. 63 CODE 801707797 ATM PIN.
- (3) Remove REF. NO. 66 CODE 801702805 SPACER.
- (4) Loosen REF. NO. 47 CODE 800014850 BOLT, REF. NO. 51 CODE 800030230 NUT, No. 50 CODE 801656400 BOLT and move REF. NO. 46 CODE 801709056 BRACKET.
- (5) Remove REF. NO. 41 CODE 801699628 TIMING BELT from REF. NO. 34 CODE 801699789 PULLEY.
- (6) Remove REF. NO. 9 CODE 801682497 BOLT and remove REF. NO. 8 CODE 801709054 FAN COVER.
- (7) Remove four REF. NO. 14 CODE 801707788 CAP BOLT fastening REF. NO. 13 CODE 801707787 COUPLING from the circumference surface.
Do not reuse bolts that have been removed.
- (8) Remove REF. NO. 33 CODE 800014850 BOLT and move HST section toward the rear.
- (9) Remove HST section from the machine.
Be careful not to damage the fan.
- (10) Loosen two REF. NO. 15.1 CODE 801699608 SCREW and remove the FAN section.
- (11) Remove REF. NO. 16 CODE 801707790 KEY from HYDROSTATIC PUMP MOTOR (HST).
- (12) Tap REF. NO. 61 CODE 801699673 SPRING PIN on outside circumference of REF. NO. 61 CODE 801699669 ARM with a rod 4.8mm in diameter and remove.

- (13) Remove REF. NO. 61 CODE 801699669 ARM from Trunnion Axis of HYDROSTATIC PUMP MOTOR (HST).
- (14) Loosen REF. NO. 23 CODE 801699619 CAP BOLT / No. 26 CODE 801658502 CAP BOLT and remove HYDROSTATIC PUMP MOTOR (HST).
- (15) Open REF. NO. 22 CODE 801699618 TANK cap, inside cover, and drain oil.
- (16) Remove REF. NO. 22 CODE 801699618 TANK from HYDROSTATIC PUMP MOTOR (HST).
- (17) Apply lithium grease to outside circumference of new HYDROSTATIC PUMP MOTOR (HST) spline shaft.
- (18) Fasten new HYDROSTATIC PUMP MOTOR (HST) with REF. NO. 23 CODE 801699619 CAP BOLT, No. 26 CODE 801658502 CAP BOLT, etc.
- (19) Insert REF. NO. 61 CODE 801699669 ARM on trunnion axis of HYDROSTATIC PUMP MOTOR (HST). After lining up hole with shaft, drive in REF. NO. 62 CODE 801699673 SPRING PIN.
- (20) Remove plug from top of HYDROSTATIC PUMP MOTOR (HST).
Reference Dimensions: 3/8inch distance between the parallel sides of a hexagon.
- (21) Mount REF. NO. 22 CODE 801699618 TANK.
- (22) Open REF. NO. 22 CODE 801699618 TANK cap, inside cover. Next, fill with oil to specified oil level.
- (23) Mount REF. NO. 22 CODE 801699618 TANK inside cover and cap.
- (24) Mount REF. NO. 16 CODE 801707790 KEY on shaft of HYDROSTATIC PUMP MOTOR (HST).
Be careful of position and orientation. See Fig. 3.
- (25) Place the FAN section in the shaft of HYDROSTATIC PUMP MOTOR (HST) and fasten with two REF. NO. 15.1 CODE 801699608 SCREW.
- (26) Mount REF. NO. 41 CODE 801699628 TIMING BELT on REF. NO. 34 CODE 801699789 PULLEY.
- (27) Attach REF. NO. 13 CODE 801707787 COUPLING to engine side REF. NO. 12 CODE 801709157 COUPLING.
- (28) Fasten REF. NO. 30 CODE 801709055 BRACKET on REF. NO. 33 CODE 800014850 BOLT.
- (29) Set REF. NO. 41 CODE 801699628 TIMING BELT tension and fasten. For procedure, see P. 21 of RR1000 instructions manual.
- (30) Turn the outside circumference of REF. NO. 13 CODE 801707787 COUPLING to line up the mounting screw section of the engine side REF. NO. 12 CODE 801709157 COUPLING with the outer circumference holes.
- (31) Fasten with four REF. NO. 14 CODE 801707788 CAP BOLT to 49 to 54N · m of torque.
- (32) Mount REF. NO. 66 CODE 801702805 SPACER on Bracket of WIRE ASSEMBLY.
- (33) Temporarily fasten WIRE ASSEMBLY with REF. NO. 63 CODE 801707797 ARM PIN.
- (33) Fasten with REF. NO. 64 CODE 801668299 CAP BOLT and REF. NO. 65 CODE 801707800 CONICAL SPRING WASHER.
- (34) For tension adjustment of WIRE and HST (Hydrostatic Pump Motor) check, see PP. 24 - 27 of RR1000 instructions manual.

11) REF. NO. 156 CODE 801709062 LINK ARM fastening position correction or replacement

- (1) Loosen REF. NO. 309 CODE 801656743 SCREW and remove REF. NO. 308 CODE 801709069 SHAFT COVER.
- (2) Loosen REF. NO. 125 CODE 801656629 BOLT and remove REF. NO. 124 CODE 801657791 SPACER.
- (3) Loosen REF. NO. 306 CODE 801656743 SCREW and remove REF. NO. 305 CODE 801709068 STEP COVER.
- (4) Remove REF. NO. 158 CODE 801656583 LOCK NUT.
- (5) Hook a belt, etc., on the T-shaped handle and retain with slight tension.
- (6) Remove REF. NO. 154 CODE 800014300 BLOT and separate the handle section from the machine.
- (7) Remove REF. NO. 155 CODE 801708139 COUPLING SLEEVE CAP BOLT (4 M5).
- (8) Screw in M5 CAP BOLT uniformly to screw section where CAP BOLT is not mounted, and separate SLEEVE from REF. NO. 150 CODE 801709169 HANDLE. When unfastened, remove CAP BOLT.
- (9) In the case of REF. NO. 156 CODE 801709062 LINK ARM replacement, reuse REF. NO. 155 CODE 801708139 COUPLING SLEEVE.
- (10) For positions of REF. NO. 150 CODE 801709169 HANDLE grip and REF. NO. 156 CODE 801709062 LINK ARM, see Fig. 4.
- (11) Tighten opposing REF. NO. 155 CODE 801708139 COUPLING SLEEVE CAP BOLT (4 M5) until uniformly fastened.
Tighten to $8.3N \cdot m$ of torque. Apply grease to COUPLING SLEEVE, CAP BOLT outer circumference.
- (12) To return to former status, perform procedure in reverse. For reference of mounting position, see Assembly drawing 102.
- (13) If moving left/right handle grip position to neutral with machine prepared for work, make sure the outer circumference of REF. NO. 183 CODE 801699724 ROLLER and left side of REF. NO. 1 CODE 801709053 FRAME are parallel.

12) REF. NO. 135 CODE 801699658 LINK ARM fastening position correction or replacement

- (1) Remove REF. NO. 139 CODE 801656398 LOCK NUT, REF. NO. 138 CODE 800030030 NUT.
- (2) Remove REF. NO. 137 CODE 801699662 BOLT from mounting section.
- (3) Remove REF. NO. 143 CODE 801654100 LOCK NUT, REF. NO. 141 CODE 801699667 BALL LINK from screw section.
- (4) Remove NUT (F), NUT (H) of REF. NO. 59 CODE 801709159 WIRE ASSEMBLY, REF. NO. 60 CODE 801709160 WIRE ASSEMBLY from screw section and then remove vertically from REF. NO. 129 CODE 801709161 BRACKET. See attached Fig. 5. Mark the WIRE ASSEMBLY after removing so you can tell the top from the bottom.
- (5) Remove REF. NO. 64 CODE 801668299 CAP BOLT and REF. NO. 65 CODE 801707800 CONICAL SPRING WASHER fastening the WIRE ASSEMBLY.

- (6) Draw out REF. NO. 63 CODE 801707797 ARM PIN.
- (7) Remove REF. NO. 66 CODE 801702805 SPACER.
- (8) Remove Bracket of WIRE ASSEMBLY from REF. NO. 61 CODE 801699669.
- (9) Remove REF. NO. 204 CODE 800014280 BOLT, REF. NO. 205 CODE 800014300 BOLT, and separate the SEAT STAY from the machine.
- (10) Loosen REF. NO. 309 CODE 801656743 SCREW and remove REF. NO. 308 CODE 801709069 SHAFT COVER.
- (11) Remove REF. NO. 125 CODE 801656629 BOLT and REF. NO. 128 CODE 801656629 BOLT.
- (12) Remove the pedal section from the machine.
- (13) Remove REF. NO. 134 CODE 800082030 RETAINING LING and REF. NO. 133 CODE 800032250 PLAIN WASHER.
- (14) Remove REF. NO. 131 CODE 801680322 RETAINING LING.
- (15) Draw out REF. NO. 130 CODE 801709162 ARM.
- (16) Remove REF. NO. 129 CODE 801709161 BRACKET.
- (17) Remove REF. NO. 140 CODE 801699663 COUPLING SLEEVE CAP BOLT (6 M4).
- (18) Screw in M4 CAP BOLT (not included) uniformly to screw section where CAP BOLT is not mounted, and separate SLEEVE from REF. NO. 122 CODE 801699646 ATM SHAFT. When unfastened, remove CAP BOLT.
- (19) In the case of REF. NO. 135 CODE 80169958 LINK ARM replacement, reuse REF. NO. 140 CODE 801699663 COUPLING SLEEVE.
- (20) For positions of REF. NO. 114 CODE 801709057 PEDAL and REF. NO. 135 CODE 80169958 LINK ARM, see Fig. 5.
- (21) Tighten opposing REF. NO. 140 CODE 801699663 COUPLING SLEEVE CAP BOLT (6 M4) until uniformly fastened. Tighten to $4.0N \cdot m$ of torque. Apply grease to COUPLING SLEEVE, CAP BOLT outer circumference.
- (22) To return to former status, perform procedure in reverse. For reference of mounting position, see Assembly drawing 102, Fig. 5 and Fig. 6.
- (23) Prepare the machine for towing, start the engine and check machine operation by operating the pedals manually. With ROLLER (Drive) stationary, make sure the distance is the same for REF. NO. 301 CODE 801709067 of both the left and right pedals.
If the distances are not the same, adjust in accordance with PP. 24 - 27 of RR1000 instructions manual.

13) REF. NO. 132 CODE 801699657 GUIDE replacement

- (1) Loosen NUT (E), NUT (G) of REF. NO. 59 CODE 801709159 WIRE ASSEMBLY and REF. NO. 60 CODE 801709160 WIRE ASSEMBLY. See attached Fig. 5.
- (2) Remove REF. NO. 143 CODE 801654100 LOCK NUT and REF. NO. 141 CODE 801699667 BALL LINK from the screw section of REF. NO. 130 CODE 801709162 ARM.
- (3) Remove REF. NO. 134 CODE 800082030 RETAINING LING. In this case, use pliers with curved

tip.

- (4) Remove REF. NO. 133 CODE 800032250 PLAIN WASHER.
- (5) Remove REF. NO. 131 CODE 801680322 RETAINING LING.
- (6) Draw out REF. NO. 130 CODE 801709162 ARM.
- (7) Slide REF. NO. 132 CODE 801699657 GUIDE up in the slot of REF. NO. 130 CODE 801709162 ARM and separate.
- (8) Mount a new REF. NO. 132 CODE 801699657 GUIDE in the slot of REF. NO. 130 CODE 801709162 ARM. Orientation does not matter when mounting.
- (9) Apply oil on the shaft of REF. NO. 130 CODE 801709162 ARM and remount REF. NO. 129 CODE 801709161 BRACKET. Slide REF. NO. 130 CODE 801709162 ARM and make sure it moves without resistance.
- (10) Mount REF. NO. 131 CODE 801680322 RETAINING LING.
- (11) Set REF. NO. 133 CODE 800032250 PLAIN WASHER.
- (12) Mount REF. NO. 134 CODE 800082030 RETAINING LING.
- (13) Apply grease to the outer circumference of REF. NO. 132 CODE 801699657 GUIDE. See Fig. 37 in RR1000 instructions manual.
- (14) To subsequently return to former status, perform procedure in reverse. For reference of mounting position, see Assembly drawing 102, Fig. 5 and Fig. 6.
- (15) Prepare the machine for towing, start the engine, and check machine operation by operating the pedals manually.

14) REF. NO. 173 CODE 801706973 BRACKET replacement

- (1) Prepare the machine for performing work.
- (2) Place stopper on the outside right side of REF. NO. 104 CODE 801699638 ROLLER.
- (3) Remove screw section of REF. NO. 172 CODE 801708142 BALL LINK JOINT Reference
Dimensions: 17mm distance between the parallel sides of a hexagon. Use a low profile spanner.
- (4) Remove REF. NO. 175 CODE 800030250 NUT.
- (5) Remove REF. NO. 174 CODE 801656583 LOCK NUT.
- (6) Mount the two belts of REF. NO. 363 CODE 801709172 SUB FRAME on the left side of the machine.
- (7) Pull the Roller (steering) section from the area of the machine.
- (8) Replace the necessary parts. Pay attention to the orientation of REF. NO. 180 CODE 801709064 ROLLER STAY and mounting position of REF. NO. 192 CODE 801699729 CAP BOLT. Refer to Assembly drawing 104.
Be careful to Fasten REF. NO. 173 CODE 801706973 BRACKET to REF. NO. 176 CODE 801657816 PILLOW BLOCK with the attached screws in two locations.
- (9) If sliding of REF. NO. 176 CODE 801657816 PILLOW BLOCK is sluggish, remove foreign matter such as sand and oil the spherical surface. Next forcibly shake the shaft to make movement smooth. After that, return to former status.
- (10) Return Roller (steering) to machine area, and hold the screw section of REF. NO. 173

CODE801706973 BRACKET vertically.

- (11) Line up the screw section with the mounting hole positions of REF. NO. 1 CODE 801709053 FRAME and then slowly lower the left end of the machine. When doing so, orient the holes on the surface of REF. NO. 173 CODE 801706973 BRACKET so they are visible.
- (12) Insert a rod, etc., in the holes to keep the bracket from turning. Reference max. rod diameter 11.5mm
- (13) Mount REF. NO. 174 CODE 801656583 LOCK NUT. Fastening torque is 60N · m.
Check the values twice with a torque wrench.
- (14) Fasten REF. NO. 175 CODE 800030250 NUT. Fastening torque is 42N · m.
- (15) To subsequently return to former status, perform procedure in reverse.

15) REF. NO. 214 CODE 801709087 BRACKET slide adjustment

- (1) Prepare the machine for performing work.
- (2-1) If you over-tighten inner side REF. NO. 213 CODE 800030240 NUT (2), you cannot move REF. NO. 214 CODE 801709087 BRACKET smoothly to the front/rear.
- (2-2) If inner side REF. NO. 213 CODE 800030240 NUT (2) is improper (does not reach proper fastening position), you cannot move the bottom edge REF. NO. 214 CODE 801709087 BRACKET (guide hole) to the left/right and cannot maintain the position of the ROLLER (Steering) when towing.
- (3) While maintaining position of the previously mentioned inner side REF. NO. 213 CODE 800030240 NUT (2), fasten the outside of inner side REF. NO. 213 CODE 800030240 NUT (2). However, apply Anaerobic Adhesive LOCTITE # 242 to the screw section.
- (4) Move the end towing section of the SUB FRAME vertically and make sure REF. NO. 214 CODE 801709087 BRACKET moves smoothly.
- (5) If REF. NO. 218 CODE 801666104 NUT has been removed, refer to Assembly drawing 105.

16) REF. NO. 324 CODE 801706816 FASTENER fastening force adjustment

- (1) With REF. NO. 324 CODE 801706816 FASTENER facing the front, the surface of both sides is fastened with slot head nuts.
- (2-1) If loosened, power to retain REF. NO. 316 CODE 801709071 BELT COVER is reduced.
- (2-2) If tightened, power to retain REF. NO. 316 CODE 801709071 BELT COVER is provided.
- (3) Adjust to the optimal position taking ease of maintenance and prevention of belt cover coming off during operation into account. Use the same amount of tightness or looseness for fasteners on both the left and right.

17) Refer to Assembly drawing 101 - 105 for other locations, disassembly or part replacement.

Check mounting sequence, etc., while performing work.

MODEL RR1000

Torque Values

MODEL RR1000

2015/4

REF. NO.	PART NO.	DESCRIPTION	Tq N·m	While it's fastening,even a process needs the torque	Tq N·m	anaerobic adhesive
1	801 709 053	FRAME				
2	701 707 775	ENGINE				
2	801 706 786	EXHAUST DEFLECTOR				
3	801 702 368	SCREW				
4	800 030 220	NUT	5.2			
5	801 699 969	BUSHING	68			
6	801 699 969	WASHER				
7	801 682 505	BOLT	12.5			
8	801 709 054	FAN COVER				
9	801 682 497	BOLT	12.5			
10	801 663 272	KEY				
11	801 707 784	SPACER				
12	801 709 157	COUPLING				
12.1	801 699 608	SCREW	22			
13	801 707 787	COUPLING				
14	801 707 788	CAP BOLT	49~54			
15	801 709 158	COUPLING				
15.1	801 699 608	SCREW	22			
16	801 707 790	KEY				
17	801 699 616	FAN				
18	800 032 020	PLAIN WASHER				
19	800 032 720	SPRING WASHER				
20	801 650 917	CAP BOLT	5.2			
21	801 699 617	HYDROSTATIC PUMP MOTOR				
22	801 699 618	TANK				
23	801 699 619	CAP BOLT	22			
24	801 654 545	CONICAL SPRING WASHER				
25	800 032 230	PLAIN WASHER				
26	801 658 502	CAP BOLT	22			
27	801 693 060	CONICAL SPRING WASHER				
28	800 032 230	PLAIN WASHER				
29	801 699 620	PUMP FLANGE				
30	801 709 055	BRACKET				
31	801 651 148	BOLT	24.5			
32	801 651 148	BOLT	24.5			
33	800 014 850	BOLT	24.5			
34	801 699 789	PULLEY				
35	801 699 623	PULLEY FLANGE				
36	801 699 624	SPACER				
37	801 699 625	RETAINING RING				
38	801 699 626	RETAINING RING				
39	801 656 139	BALL BEARING				
40	801 699 627	BALL BEARING				
41	801 699 628	TIMING BELT				
42	801 699 629	PULLEY				
43	801 699 630	PULLEY SHAFT				
44	801 699 631	KEY				
45	801 651 069	SCREW	22			
46	801 709 056	BRACKET				
47	800 014 850	BOLT	24.5			
48	801 657 816	PILLOW BLOCK				
49	800 014 850	BOLT	24.5			
50	801 656 400	BOLT	---			
51	800 030 230	NUT	12.5			
52	801 699 633	SPROCKET				
53	801 699 634	KEY				
54	801 651 379	SCREW	9.2			
55	801 676 126	WASHER				
56	800 014 050	BOLT	12.5			
57	801 675 631	WASHER				

MODEL RR1000

2015/4

REF. NO.	PART NO.	DESCRIPTION	Tq N•m	While it's fastening,even a process needs the torque	Tq N•m	anaerobic adhesive
58	800 017 870	BOLT	5.2			
59	801 709 159	WIRE ASSEMBLY	12.5(NUT)			
60	801 709 160	WIRE ASSEMBLY	12.5(NUT)			
61	801 699 669	ARM				
62	801 699 673	SPRING PIN				
63	801 707 797	ARM PIN				
64	801 668 299	CAP BOLT	5.4			
65	801 707 800	CONICAL SPRING WASHER				
66	801 702 805	SPACER				
67	801 709 059	BRACKET				
68	801 651 021	CAP BOLT	22			
69	800 032 730	SPRING WASHER				
70	801 699 681	SPRING GUIDE				
71	801 699 682	STUD BOLT	12.5			
72	800 030 030	NUT	12.5			
73	801 656 398	LOCK NUT	12.5	**		
74	801 699 683	SPRING				
75	801 654 433	CAP BOLT	9.2			
76	801 699 684	ARM				
77	801 658 502	CAP BOLT	22			
78	800 032 230	PLAIN WASHER				
79	800 030 230	NUT	12.5			
80	801 658 604	BALL BEARING				
81	801 699 686	WASHER				
82	801 699 687	BEARING SHAFT				
83	800 082 010	RETAINING RING				
84	801 702 243	BRACKET				
85	800 014 840	BOLT				
86	801 702 244	PIN				
87	800 032 230	PLAIN WASHER				
88	801 699 679	SPLIT PIN				
89	801 702 245	DAMPER				
90	801 702 246	BOLT				
91	801 656 398	LOCK NUT	12.5	**		
92	800 032 230	PLAIN WASHER				
93	801 699 679	SPLIT PIN				

MODEL RR1000

2015/4

REF. NO.	PART NO.	DESCRIPTION	Tq N•m	While it's fastening,even a process needs the torque	Tq N•m	anaerobic adhesive
101	801 699 635	CHAIN				
102	801 699 636	CHAIN JOINT				
103	801 699 637	OFFSET LINK				
104	801 699 638	ROLLER				
105	801 657 761	PILLOW BLOCK				
106	801 699 639	SPACER				
107	800 011 540	BOLT	24.5			
108	801 693 071	CONICAL SPRING WASHER				
109	801 699 640	SPROCKET				
110	801 699 641	KEY				
111	801 651 069	SCREW	22			
112	801 673 944	WASHER				
113	801 651 148	BOLT	24.5			
114	801 709 057	PEDAL				
115	801 699 644	SLIP-PROOF SHEET				
116	801 699 645	SCREW	1.5			
117	800 031 210	LOCK NUT	1.5	**		
118	801 654 436	SCREW	9.2			
119	801 657 790	KEY				
120	801 675 631	WASHER				
121	800 014 050	BOLT	12.5			
122	801 699 646	ARM SHAFT				
123	801 657 789	PILLOW BLOCK				
124	801 657 791	SPACER				
125	801 656 629	BOLT	12.5			
126	801 657 789	PILLOW BLOCK				
127	801 699 647	SPACER				
128	801 656 629	BOLT	12.5			
129	801 709 161	ARM LINK				
130	801 709 162	ARM				
131	801 680 322	RETAINING RING				
132	801 699 657	GUIDE				
133	800 032 250	PLAIN WASHER				
134	800 082 030	RETAINING RING				
135	801 699 658	ARM LINK				
136	801 658 363	SPRING				
137	801 699 662	BOLT				
138	800 030 030	NUT	12.5			
139	801 656 398	LOCK NUT	12.5	**		
140	801 699 663	COUPLING SLEEVE	4			
141	801 699 667	BALL LINK JOINT				
142	800 030 180	NUT	3			
143	801 654 100	LOCK NUT	3	**		
144	801 702 522	BOLT				
145	801 702 523	BOLT				
146	800 030 230	NUT	12.5			
147	801 709 058	BRACKET				
148	801 653 712	CAP BOLT	9.2			
149	800 032 720	SPRING WASHER				
150	801 709 169	HANDLE				
151	801 709 061	HANDLE SHAFT HOLDER				
152	801 657 082	BALL BEARING				
153	801 657 743	RETAINING RING				
154	800 014 300	BOLT				
155	801 708 139	COUPLING SLEEVE	8.3			
156	801 709 062	LINK ARM				
157	801 708 142	BALL LINK JOINT				
158	801 656 583	LOCK NUT	50			
159	800 030 250	NUT	42			
160	801 708 143	BOLT				

MODEL RR1000

2015/4

REF. NO.	PART NO.	DESCRIPTION	Tq N•m	While it's fastening,even a process needs the torque	Tq N•m	anaerobic adhesive
161	800 030 250	NUT	42			
162	801 708 142	BALL LINK JOINT			42	LOCTITE #242
163	801 709 063	LINK ARM				
164	800 046 020	BALL BEARING				
165	801 668 111	RETAINING RING				
166	801 669 635	WASHER				
167	800 017 870	BOLT			5.2	LOCTITE #242
168	801 708 142	BALL LINK JOINT			42	LOCTITE #242
169	800 030 250	NUT	42			
170	801 708 146	BOLT				
171	800 030 250	NUT	42			
172	801 708 142	BALL LINK JOINT	42			
173	801 706 973	BRACKET				
174	801 656 583	LOCK NUT	60			
175	800 030 250	NUT	42			
176	801 657 816	PILLOW BLOCK				
177	801 672 441	WASHER				
178	801 699 720	BOLT	42			
179	801 699 721	BOLT	24.5			
180	801 709 064	ROLLER STAY				
181	801 699 723	STOPPER				
182	800 014 260	BOLT	12.5			
183	801 699 724	ROLLER				
184	801 699 725	PILLOW BLOCK				
185	801 699 726	BOLT	12.5			
186	801 693 060	CONICAL SPRING WASHER				
187	801 699 727	ROLLER SHAFT				
188	800 082 150	RETAINING RING				
189	801 699 728	DISK				
190	801 654 803	LOCK NUT	5.2			
191	800 014 840	BOLT	24.5			
192	801 699 729	CAP BOLT	44			
193	801 699 730	SEAT				
194	800 014 280	BOLT	12.5			
195	801 709 065	SEAT BRACKET				
196	801 706 825	CUSHION				
197	801 658 552	CAP BOLT			9.2	LOCTITE #242
198	801 708 334	HINGE				
199	800 017 740	BOLT	5.2			
200	800 031 221	LOCK NUT	5.2	**		
201	801 708 335	BOLT	9.2			
202	800 031 221	LOCK NUT	5.2	**		
203	801 709 066	SEAT STAY				
204	800 014 280	BOLT	12.5			
205	800 014 300	BOLT	12.5			
206	801 699 746	MUFFLER GUARD				
207	800 017 870	BOLT	5.2			
208	801 702 801	FASTENER				
209	801 708 352	SCREW			5.4	LOCTITE #242
210	801 699 751	CAP BOLT	44			
211	801 709 164	GUIDE PLATE				
212	800 032 240	PLAIN WASHER				
213	800 030 240	NUT			24.5	LOCTITE #242
214	801 709 087	BRACKET				
215	801 699 794	LINK SHAFT				
216	800 032 230	PLAIN WASHER				
217	801 671 293	SPLIT PIN				
218	801 666 104	NUT				
219	800 030 230	NUT	12.5			
220	801 702 506	LINK BOLT				

MODEL RR1000

2015/4

REF. NO.	PART NO.	DESCRIPTION	Tq N•m	While it's fastening,even a process needs the torque	Tq N•m	anaerobic adhesive
221	800 032 230	PLAIN WASHER				
222	801 701 757	SPRING				
223	800 030 230	NUT	12.5			
224	801 699 796	STOPPER				
225	801 699 797	CAP BOLT				

MODEL RR1000

2015/4

REF. NO.	PART NO.	DESCRIPTION	Tq N•m	While it's fastening,even a process needs the torque	Tq N•m	anaerobic adhesive
301	801 709 067	STEP				
302	801 702 624	SHEET				
303	801 656 743	SCREW	5.2			
304	801 656 585	WASHER				
305	801 709 068	STEP COVER				
306	801 656 743	SCREW	5.2			
307	801 656 585	WASHER				
308	801 709 069	SHAFT COVER				
309	801 656 743	SCREW	5.2			
310	801 656 585	WASHER				
311	801 709 070	COVER BRACKET				
312	800 014 840	BOLT	24.5			
313	801 657 490	HINGE				
314	801 657 823	PLATE NUT				
315	800 018 340	BOLT	5.2			
316	801 709 071	BELT COVER				
317	801 699 753	CUSHION				
318	801 699 754	CUSHION				
319	801 699 755	CUSHION				
320	801 709 072	BRACKET				
321	801 706 814	BOLT				
322	801 666 539	LOCK NUT	15.5			
323	801 706 815	PLUG				
324	801 706 816	FASTENER				
325	801 671 317	SCREW			1.5	LOCTITE #242
326	801 709 073	BRACKET				
327	800 014 300	BOLT	12.5			
328	801 709 170	SUB FRAME				
329	801 657 804	WASHER				
330	800 014 060	BOLT	12.5			
331	801 657 825	TIRE				
332	801 709 128	PLAIN WASHER				
333	801 657 733	SPLIT PIN				
334	801 709 075	STOPPER				
335	800 014 300	BOLT	12.5			
336	801 657 801	SPACER				
337	801 657 802	STOPPER				
338	801 682 505	BOLT	12.5			
339	801 709 171	BRACKET				
340	800 014 840	BOLT	24.5			
341	801 709 077	STOPPER				
342	801 699 769	SHAFT				
343	801 651 069	SCREW	22			
344	800 030 230	NUT	12.5			
345	801 699 770	SPRING				
346	801 706 807	STOPPER				
347	801 699 772	HINGE				
348	801 691 458	SCREW				
349	800 032 712	SPRING WASHER				
350	800 030 013	NUT	1.5			
351	801 699 773	CAP BOLT	2.7			
352	801 676 569	CONICAL SPRING WASHER				
353	801 699 774	KNOB BOLT				
354	801 656 398	LOCK NUT	12.5	**		
355	801 709 078	STOPPER				
356	801 706 822	GRIP				
357	800 030 250	NUT	42			
358	800 032 250	PLAIN WASHER				
359	800 084 040	SNAP PIN				
360	801 699 776	SPRING				

MODEL RR1000

2015/4

REF. NO.	PART NO.	DESCRIPTION	Tq N•m	While it's fastening,even a process needs the torque	Tq N•m	anaerobic adhesive
361	801 709 079	BRACKET				
362	800 014 840	BOLT	24.5			
363	801 709 172	SUB FRAME				
364	801 657 804	WASHER				
365	800 014 060	BOLT	12.5			
366	801 657 825	TIRE				
367	801 709 128	PLAIN WASHER				
368	801 657 733	SPLIT PIN				
369	801 709 173	BRACKET				
370	800 014 840	BOLT	24.5			
371	801 709 082	STOPPER				
372	801 699 769	SHAFT				
373	801 651 069	SCREW	22			
374	800 030 230	NUT	12.5			
375	801 699 770	SPRING				
376	801 706 807	STOPPER				
377	801 699 772	HINGE				
378	801 691 458	SCREW				
379	800 032 712	SPRING WASHER				
380	800 030 013	NUT	1.5			
381	801 699 773	CAP BOLT	2.7			
382	801 676 569	CONICAL SPRING WASHER				
383	801 699 774	KNOB BOLT				
384	801 656 398	LOCK NUT	12.5	**		
385	801 709 083	BRACKET				
386	801 699 784	PIPE				
387	801 709 084	BRACKET				
388	800 011 670	BOLT				
389	800 032 240	PLAIN WASHER				
390	801 666 540	LOCK NUT	24			
391	801 709 065	STAND				
392	801 709 086	BRACKET				
393	801 699 788	BOLT	12.5			
394	800 010 530	BOLT	5.2			
395	800 032 220	PLAIN WASHER				
396	800 032 720	SPRING WASHER				
397	800 030 020	NUT	5.2			
398	801 706 981	HOLDER				
399	801 699 790	STAND PIN				
400	800 080 700	RETAINING RING				
401	801 709 090	SLIP-PROOF SHEET				
402	801 709 091	SLIP-PROOF SHEET				
403	801 709 092	PROTECTOR				

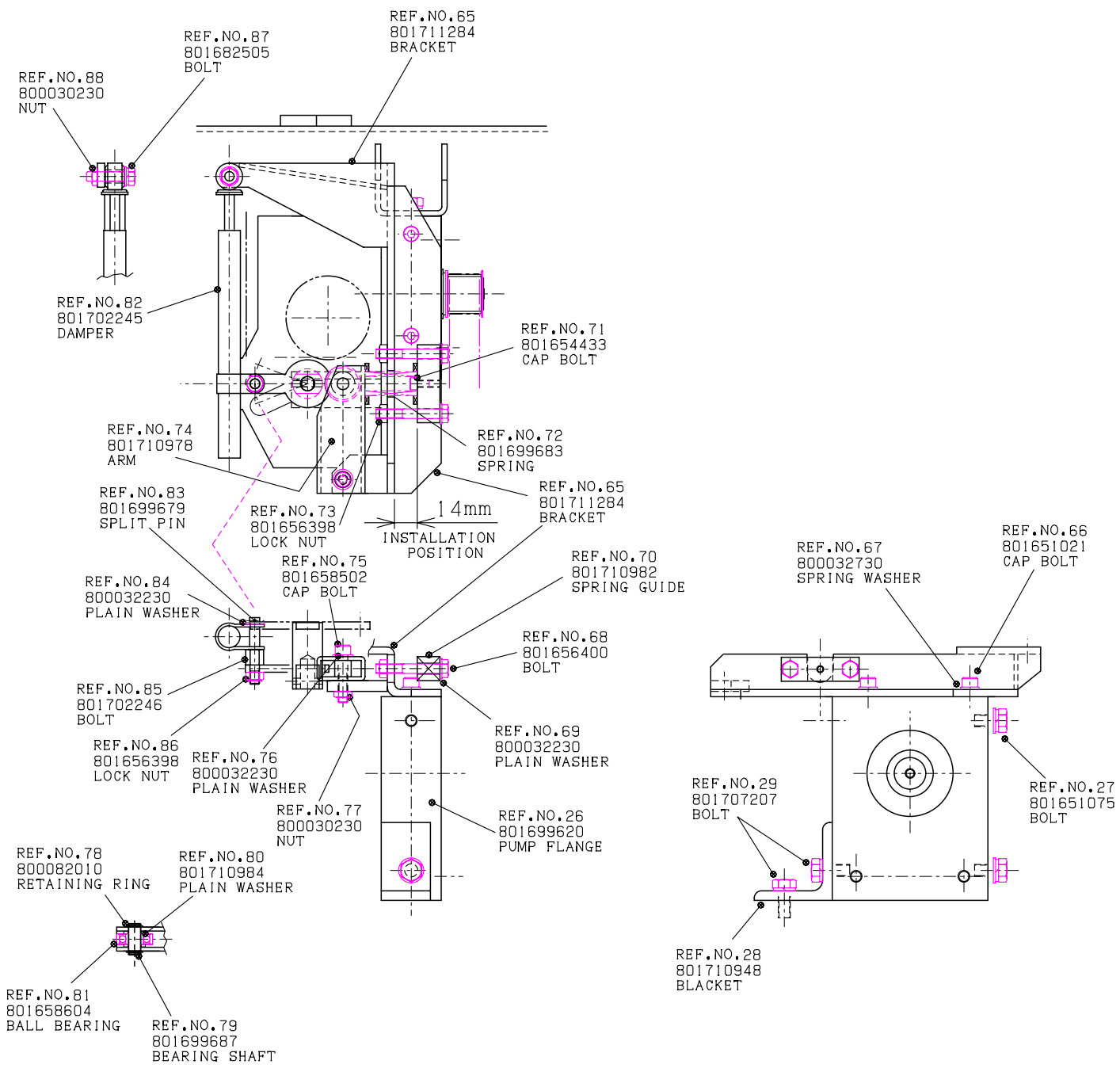

FIG. 1

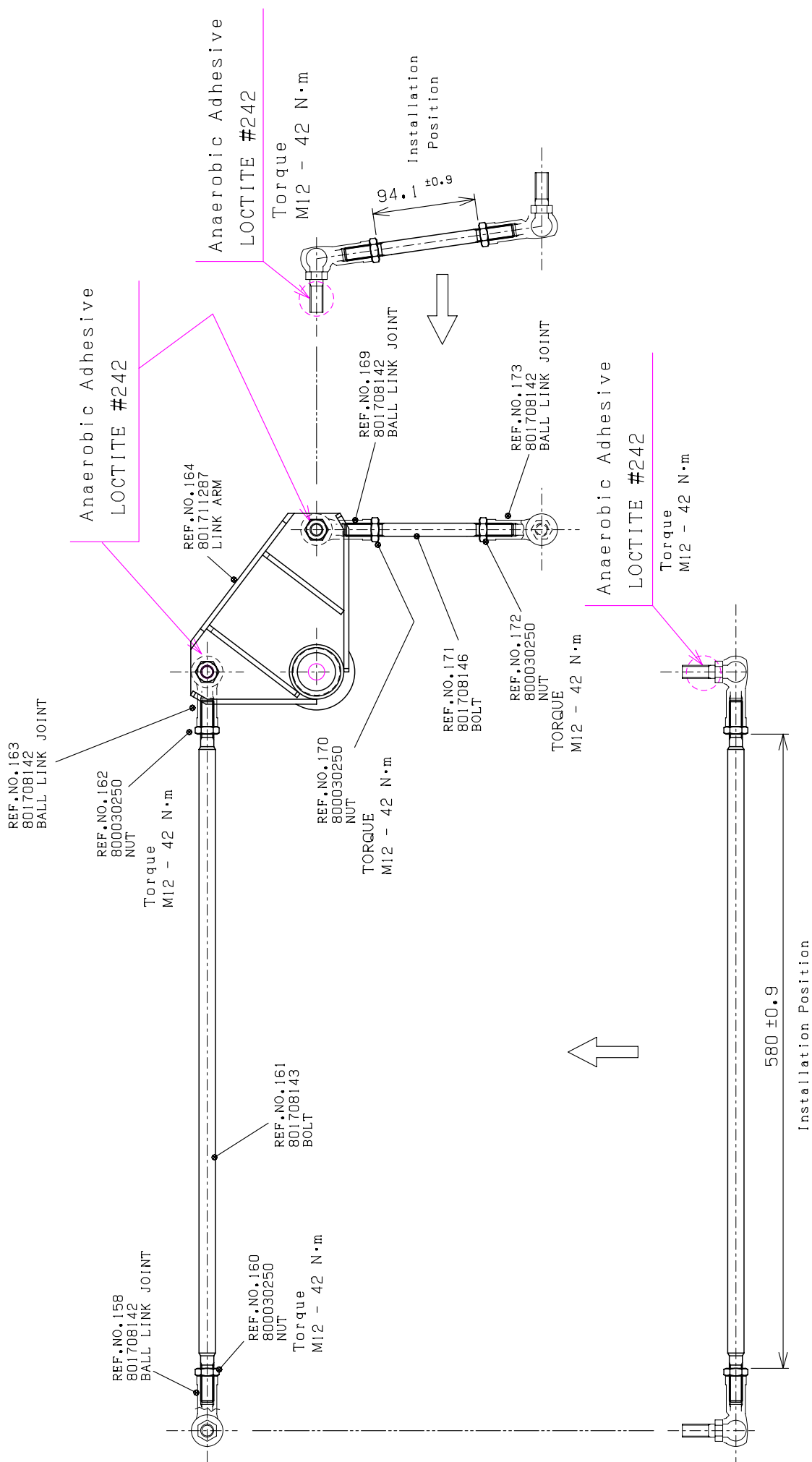

FIG. 2

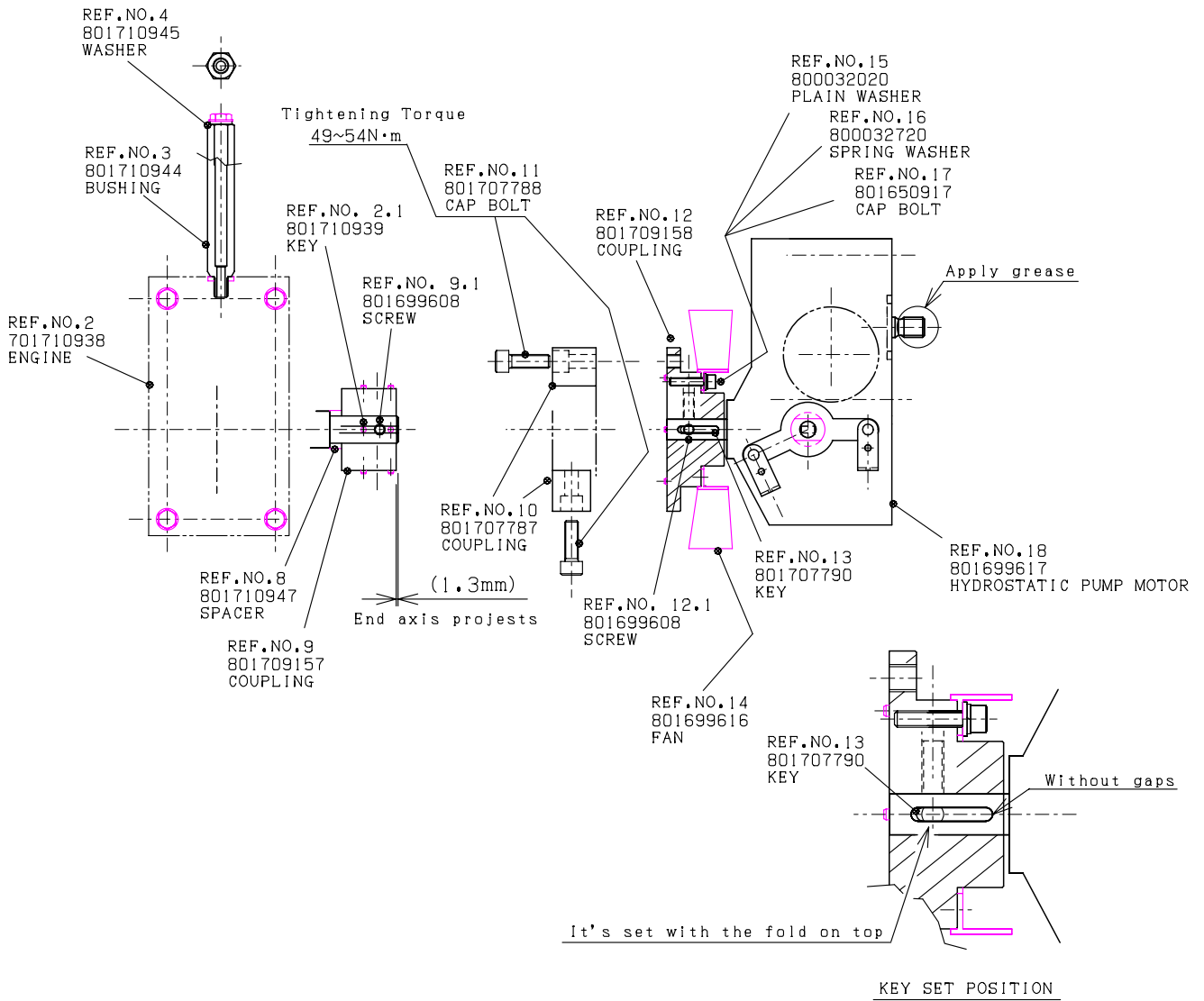

FIG. 3

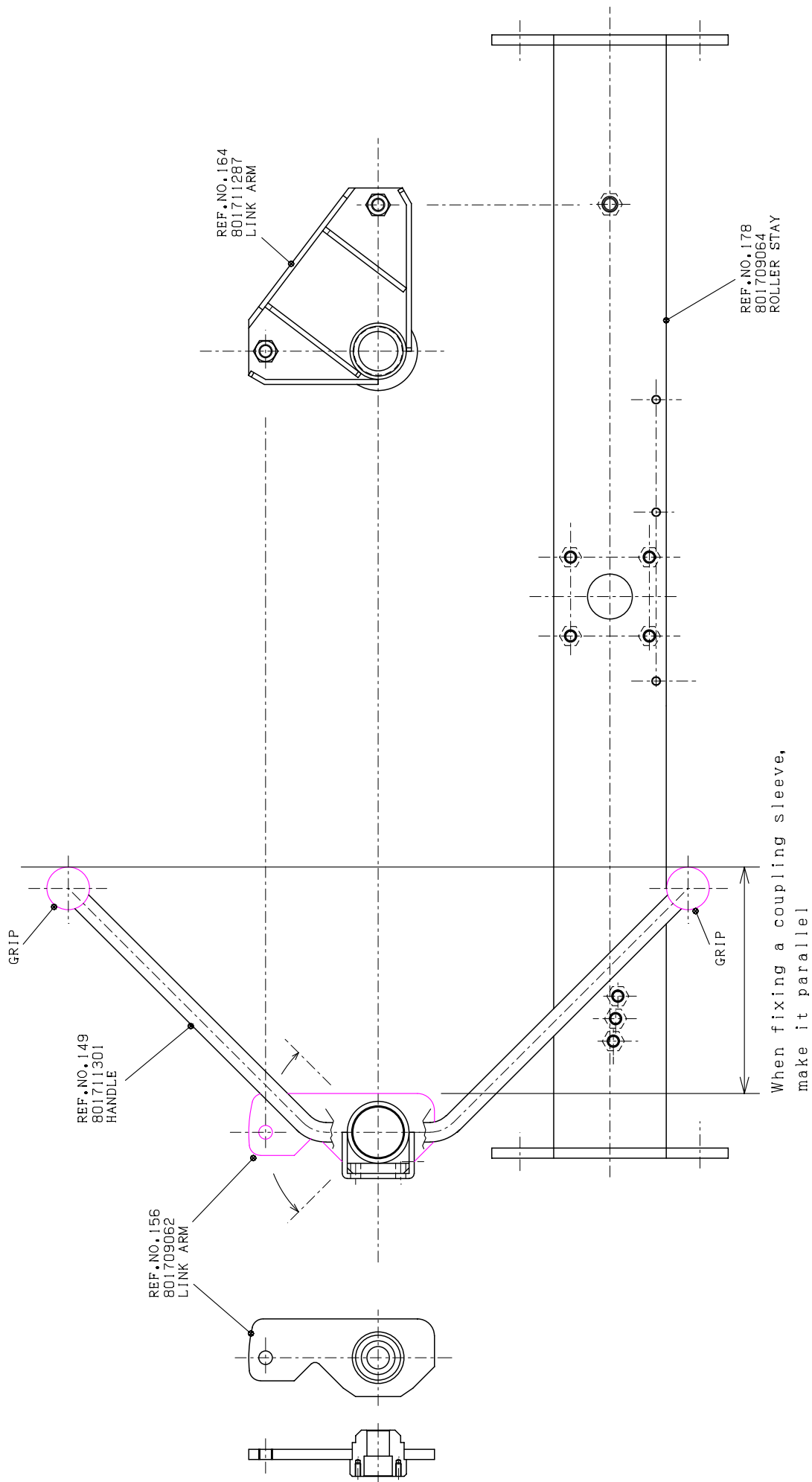
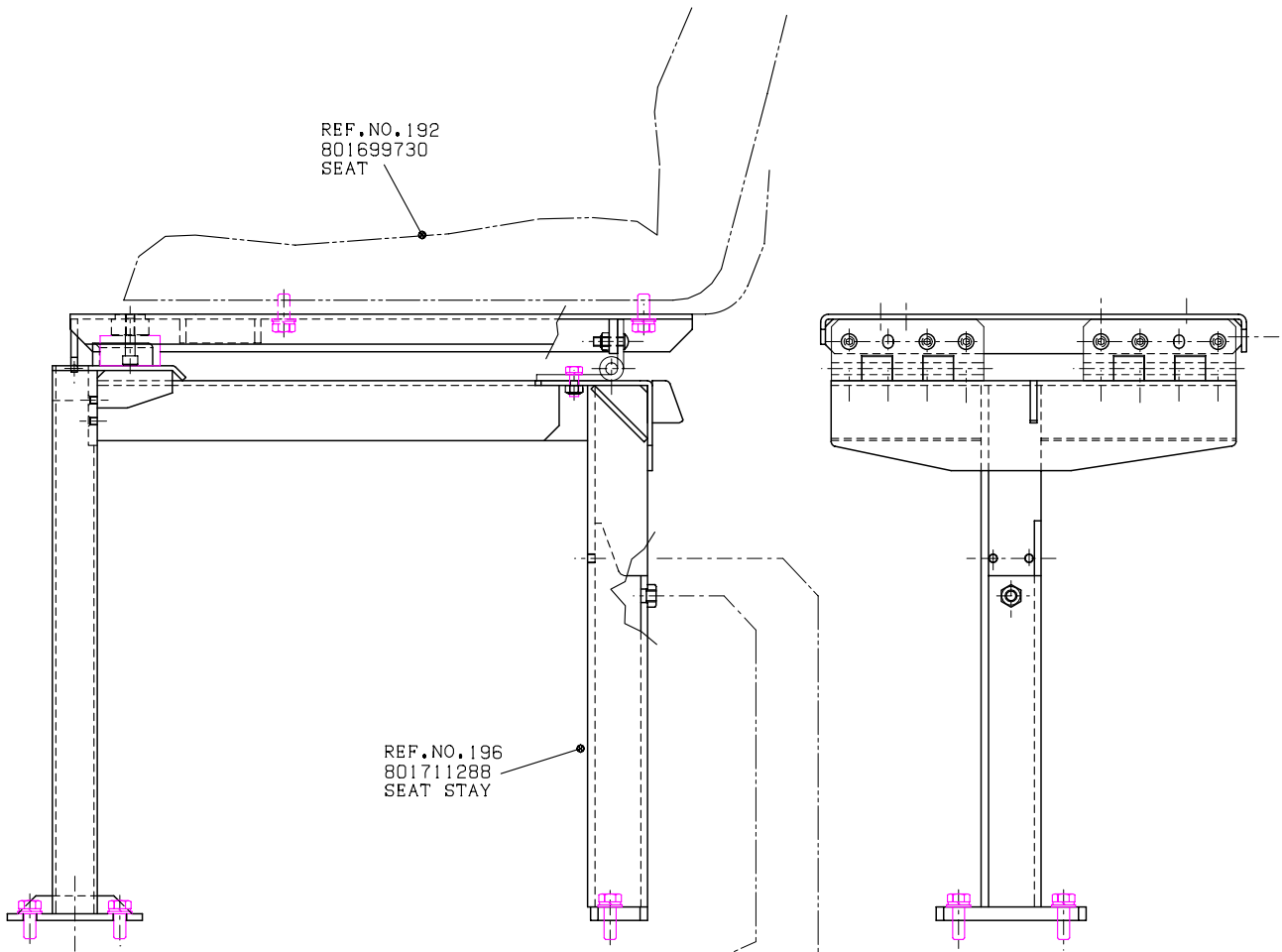

FIG. 4



REF. NO. 192
801699730
SEAT

REF. NO. 196
801711288
SEAT STAY

Do a mounting point of a wire assembly
in the last
It's spread and the condition is
established so that a pedal
in left and right may become parallel
to a frame
Spread as there is no slack
for an inner wire

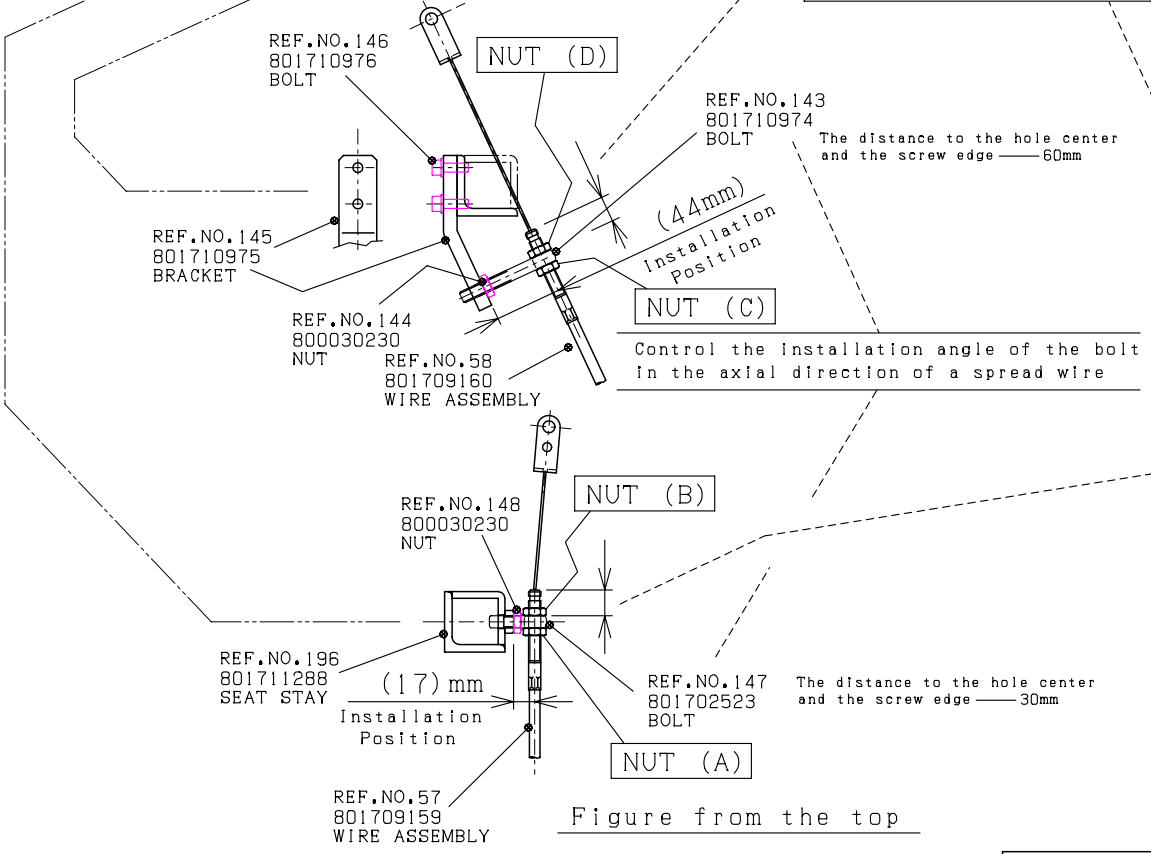

REF. NO. 146
801710976
BOLT

NUT (D)

REF. NO. 143
801710974
BOLT

The distance to the hole center
and the screw edge — 60mm

REF. NO. 145
801710975
BRACKET

(44mm)
Installation
Position

NUT (C)

REF. NO. 144
800030230
NUT

REF. NO. 58
801709160
WIRE ASSEMBLY

Control the installation angle of the bolt
in the axial direction of a spread wire

REF. NO. 148
800030230
NUT

NUT (B)

REF. NO. 196
801711288
SEAT STAY

(17mm)
Installation
Position

REF. NO. 147
801702523
BOLT

The distance to the hole center
and the screw edge — 30mm

NUT (A)

REF. NO. 57
801709159
WIRE ASSEMBLY

Figure from the top

Refer to Assembly drawing 102.

FIG. 6

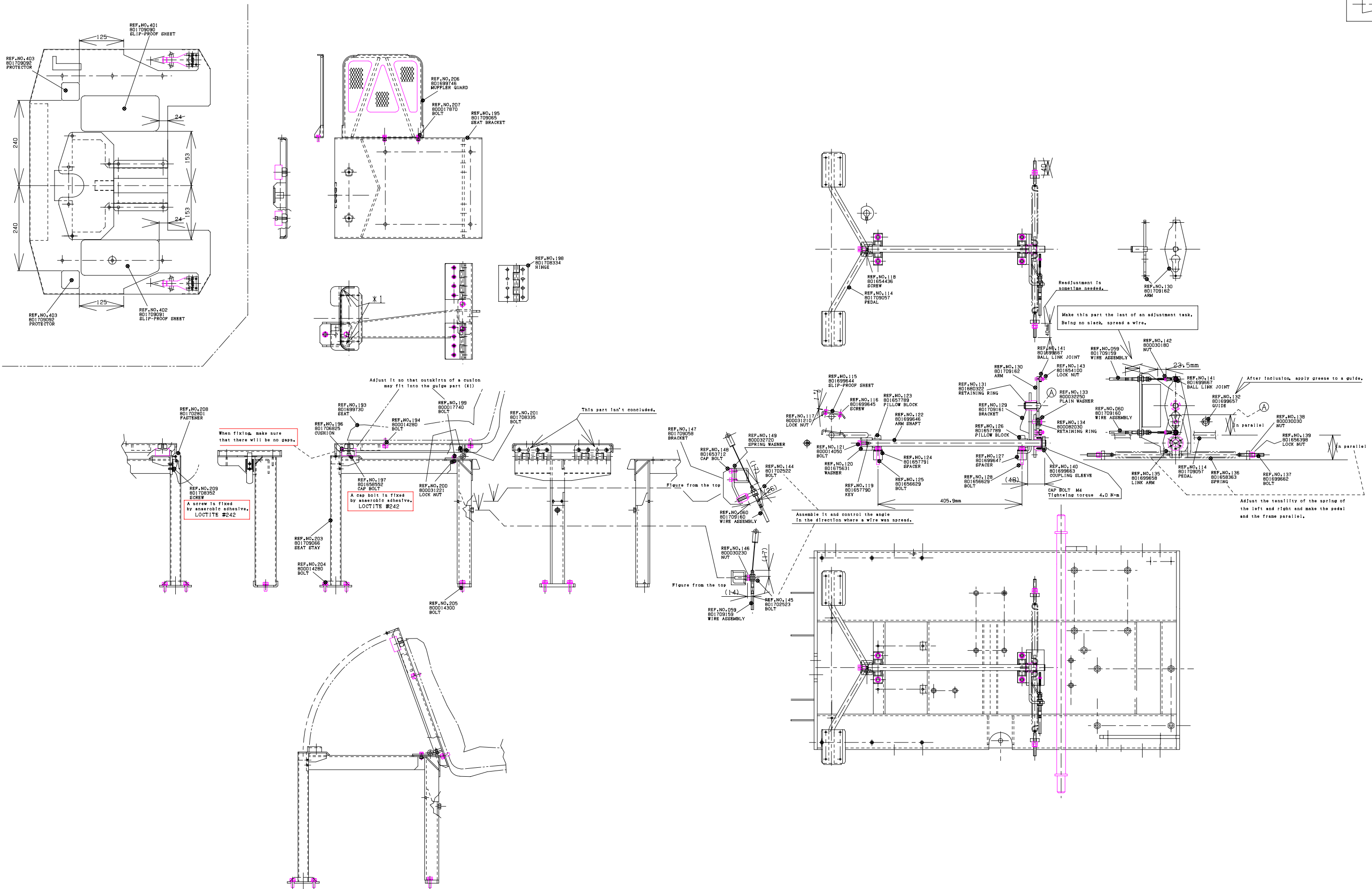
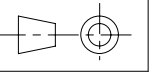

Exterior		MODEL
Material		RR1000
Finish state		NAME
Scale	1:5	Date
Design	k.yamauchi	Date
		150223
		Assembly drawing
		CODE
		102

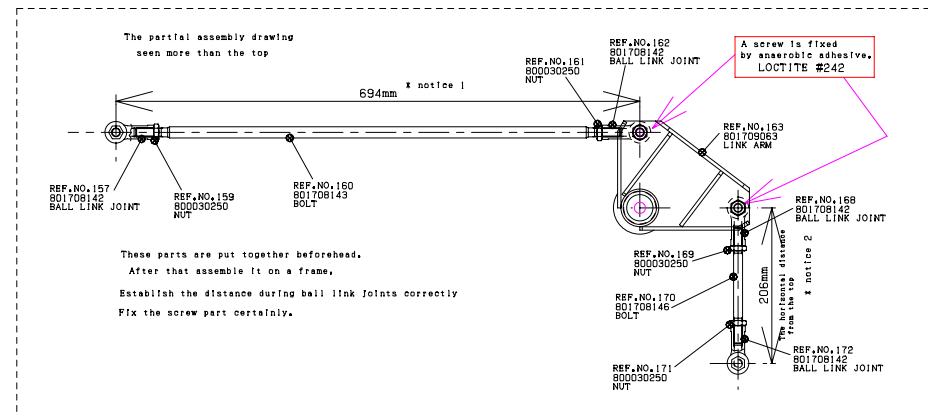
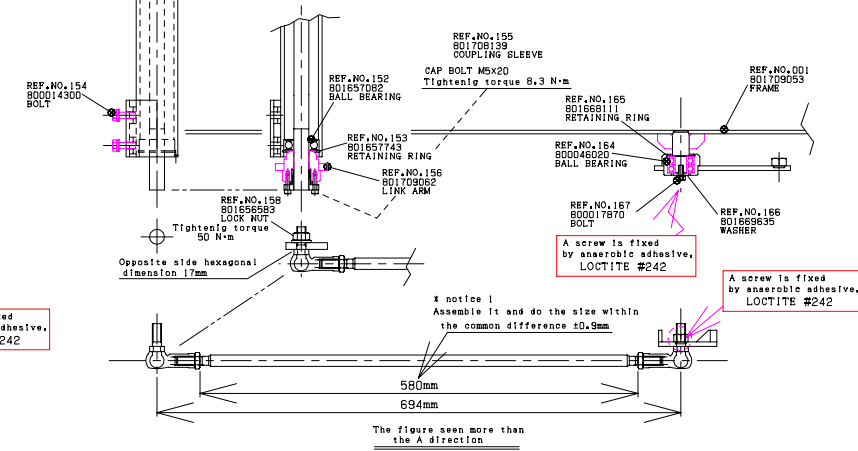
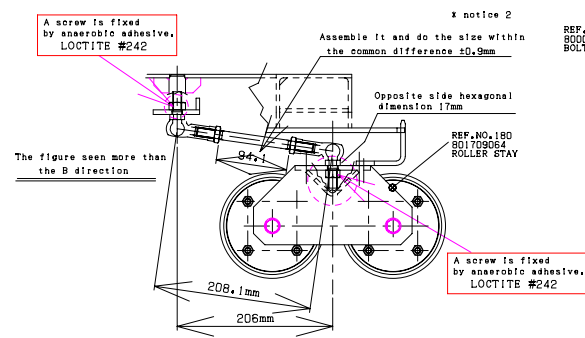
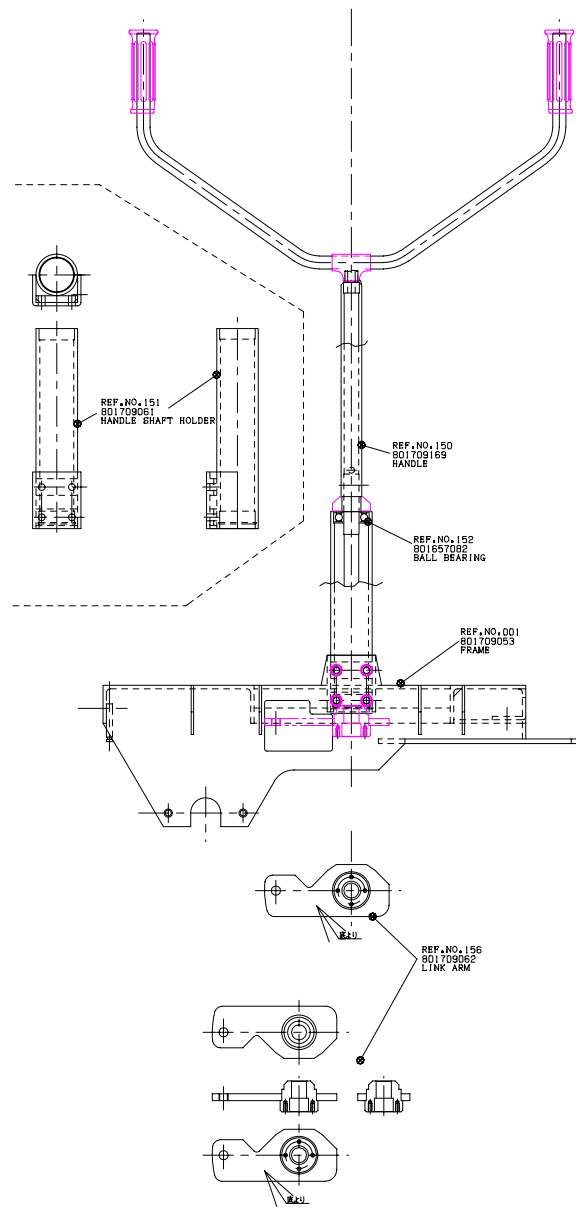
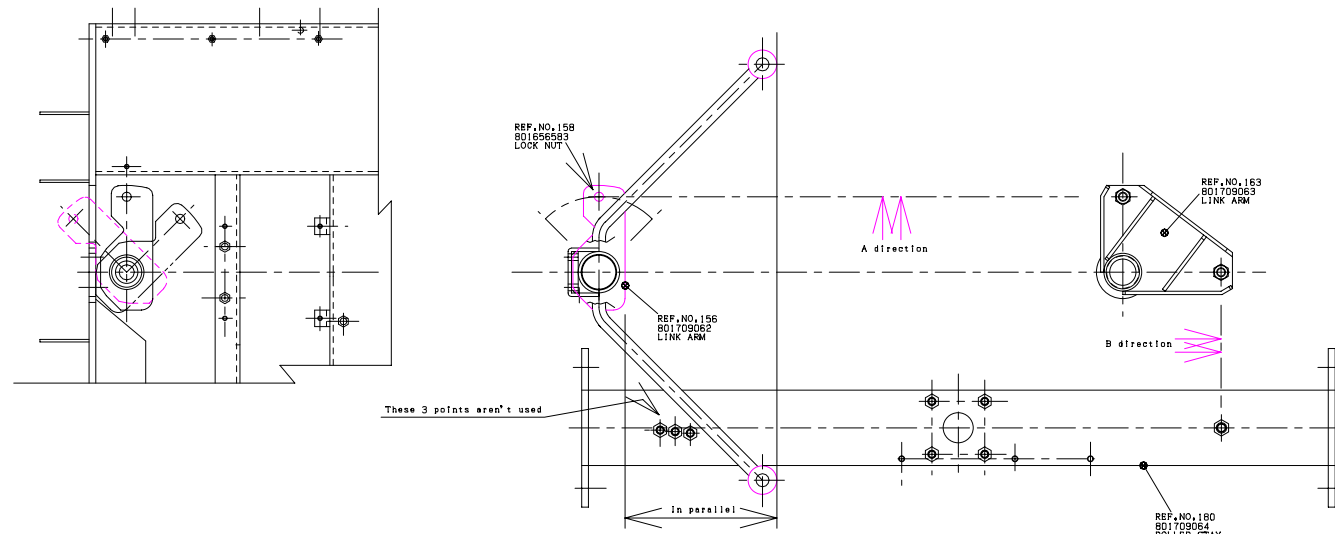
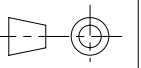

These parts are put together beforehand.
After that assemble it on a frame.
Establish the distance during ball link joints correctly.
Fix the screw part certainly.

Exterior		MODEL
Material		RR1000
Finish state		NAME
Scale	1:5	Date 150223
Design	k.yamauchi	CODE
		103

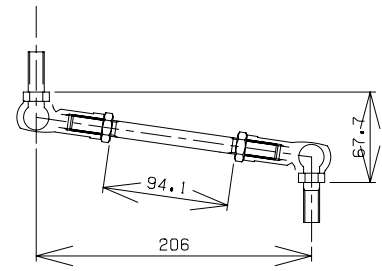
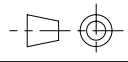

REF.NO.168
801708142
BALL LINK JOINT

REF.NO.170
801708146
BOLT

REF.NO.169
800030250
NUT

REF.NO.191
800014840
BOLT

Refer to assembly drawing 103
for a conclusion in this part.

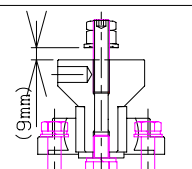
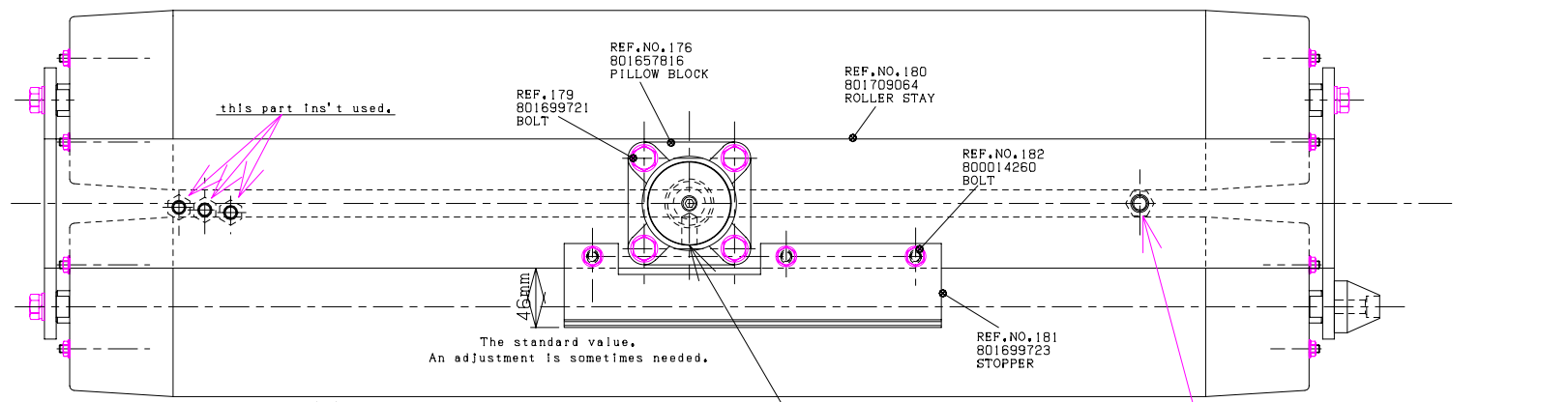

REF.NO.224
801699796
STOPPER

REF.NO.225
801699797
CAP BOLT

REF.NO.192
801699729
CAP BOLT

REF.NO.191
800014840
BOLT

REF.NO.174
801656583
LOCK NUT

Tightening torque 60N·m

REF.NO.175
800030250
NUT

REF.NO.173
801706973
BRACKET

REF.NO.179
801699721
BOLT

REF.NO.176
801657816
PILLOW BLOCK

REF.NO.177
801672441
WASHER

REF.NO.178
801699720
BOLT

REF.NO.183
801699724
ROLLER

REF.NO.185
801699726
BOLT

REF.NO.184
801699725
PILLOW BLOCK

REF.NO.186
801693060
CONICAL SPRING WASHER

REF.NO.190
801654803
LOCK NUT

REF.NO.187
801699727
ROLLER SHAFT

REF.NO.188
800082150
RETAINING RING

REF.NO.189
801699728
DISK

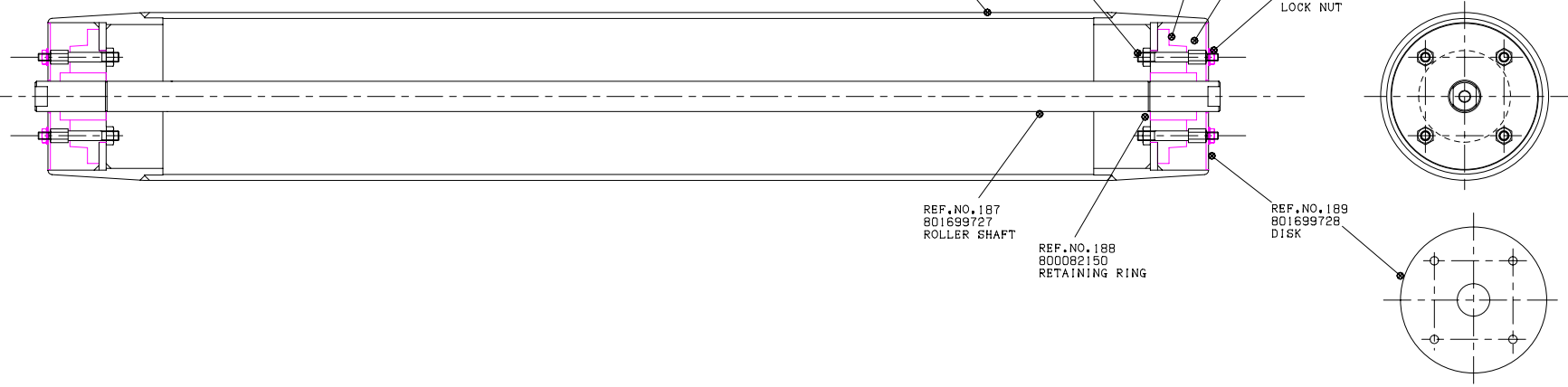

Exterior	MODEL
Material	RR1000
Finish state	NAME
Scale 1:5 Date 150223	Assembly drawing
Design K.Yamauchi	CODE
	104

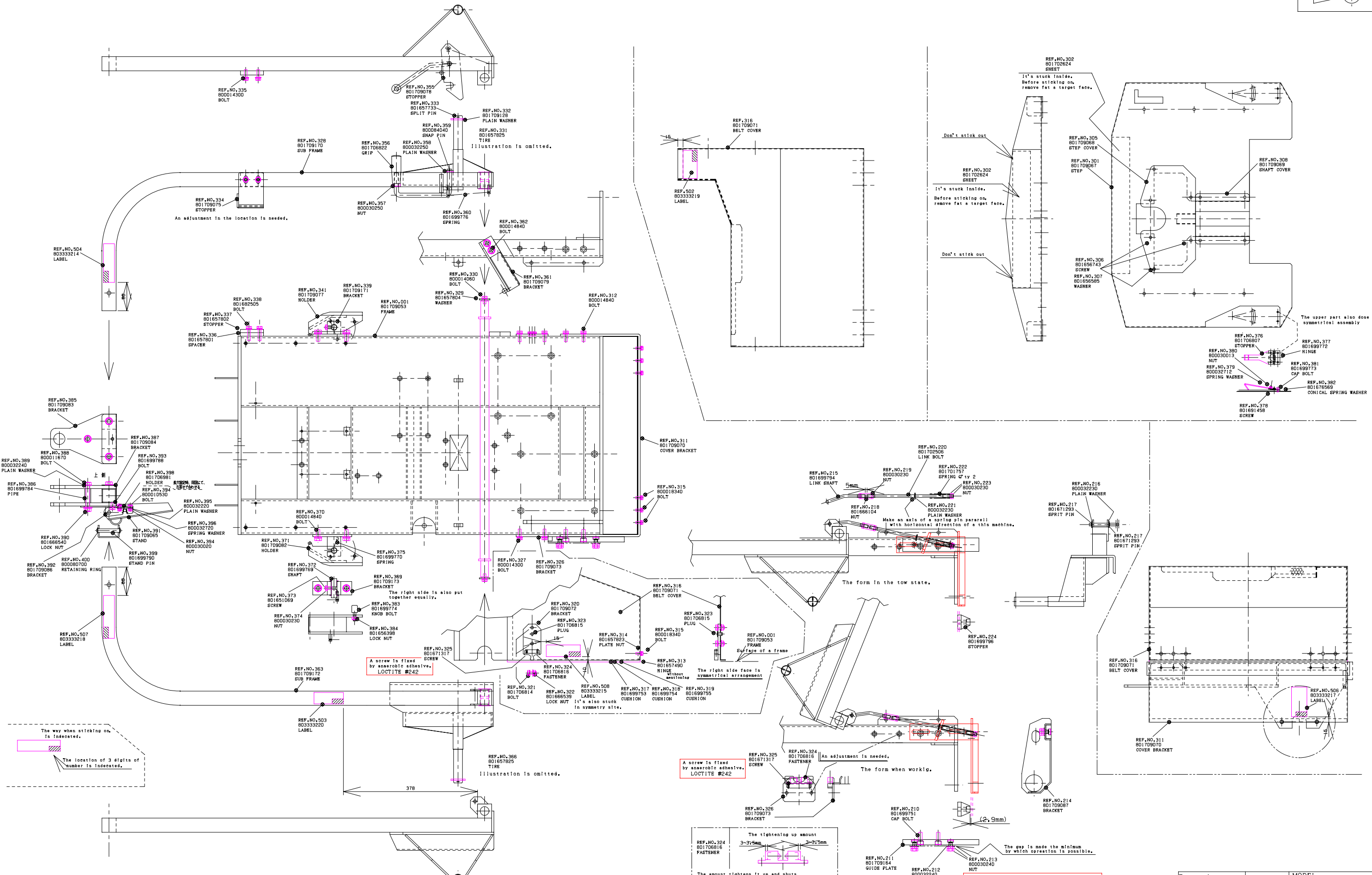
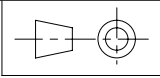

REF. NO. 302 801702624 SHEET

It's stuck inside. Before sticking on, remove fat at target face.

Don't stick out

It's stuck inside. Before sticking on, remove fat at target face.

Don't stick out

The upper part also dose symmetrical assembly

REF. NO. 376 801709071 STOPPER

REF. NO. 377 801699772 RINGE

REF. NO. 378 801699773 CAP BOLT

REF. NO. 379 800030220 SPRING WASHER

REF. NO. 380 800030220 NUT

REF. NO. 381 801699773 CONICAL SPRING WASHER

REF. NO. 382 801691458 SCREW

REF. NO. 215 801699754 LINK SHAFT

REF. NO. 218 801666104 NUT

REF. NO. 219 800030230 NUT

REF. NO. 220 801702508 LINK BOLT

REF. NO. 221 800032230 PLAIN WASHER

REF. NO. 222 801701767 SPRING of ty 2

REF. NO. 223 800030230 NUT

REF. NO. 216 800032230 PLAIN WASHER

REF. NO. 217 801671293 SPRIT PIN

REF. NO. 214 801709067 BRACKET

REF. NO. 210 801699751 CAP BOLT

REF. NO. 211 801709184 GUIDE PLATE

REF. NO. 212 800030240 PLAIN WASHER

REF. NO. 213 800030240 NUT

The gap is made the minimum by which operation is possible.

After confirming that you can slide, the outside nut is fixed by anaerobic adhesive, LOCTITE #242.

The form in the tow state.

The form when working.

A screw is fixed by anaerobic adhesive, LOCTITE #242.

REF. NO. 324 801706816 PASTENER

The amount tightens it up and shuts a belt cover, judges the sense resultant and establishes it.

The tightening up amount 3-7.5mm

A screw is fixed by anaerobic adhesive, LOCTITE #242.

REF. NO. 366 801657825 TIRE

Illustration is omitted.

The right side is also put together equally.

The right side face is symmetrical arrangement

REF. NO. 322 80333215 LABEL

REF. NO. 317 801699753 CUSHION

REF. NO. 318 801699754 CUSHION

REF. NO. 319 801699755 CUSHION

It's also stuck in symmetry site.

The way when sticking on is indicated.

The location of 3 digits of number is indicated.

Exterior		MODEL	RR1000
Material		NAME	
Finish state		Assembly drawing	
Scale 1:5	Date 150223	CODE	
Design k.yamauchi			105

BARONESS[®]
Quality on Demand



KYOEISHA CO., LTD.

Head Office 1-26, Miyuki-cho, Toyokawa, Tel : (0533)84-1390
Aichi-Pref. 442-8530 Japan. Fax : (0533)89-3623