

***HMA1560***  
***HMA1720***

# KYOEISHA HAMMER KNIFE MOWER

Service Manual

2005

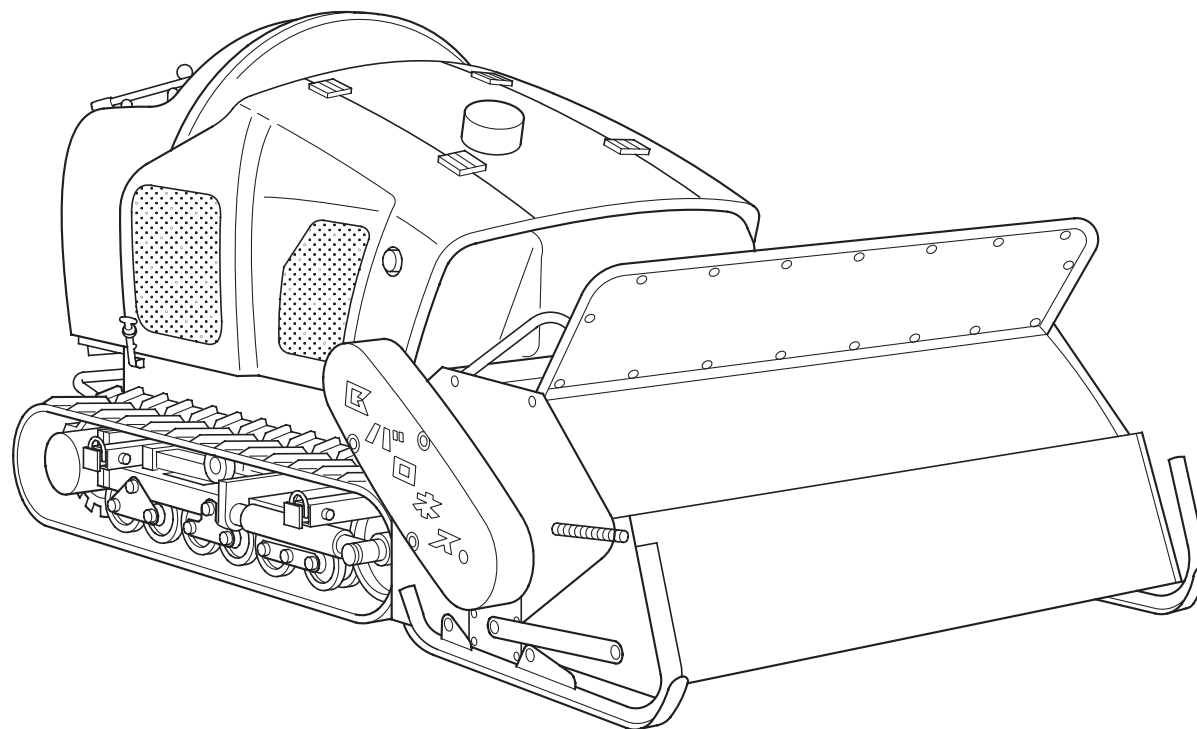

## Introduction

This service manual explains the specifications and maintenance procedures for our Hammer Knife Mower, HMA1560/HMA1720.

### Notes

1. This manual was prepared in January 2005. Its contents are subject to change for improvement without notice.
2. Carefully read “Owner's Handling Manual” and understand the contents well to ensure safety during maintenance and repair.
3. Maintain the machine sufficiently to allow the machine to deliver better performance.
4. All rights reserved

# CONTENTS

1. Specifications .....	2
2. Maintenance schedule .....	2
3. List of major power transmission parts .....	3
4. Wiring diagram .....	4
5. Electrical equipment .....	5
5-1. Electrical equipment box .....	5
5-2. Fuse box .....	5
6. Hydraulic circuit and equipment .....	6~7
7. Maintenance of each part .....	8~17
7-1. Hydraulic system .....	8
7-2. Engine .....	9
7-3. Fuel system/radiator .....	10
7-4. Air cleaner/battery .....	11
7-5. Step .....	12
7-6. Belt adjustment .....	13
7-7. Adjustment and detachment of rubber crawler .....	14
7-8. Adjustment of the neutral position of piston pump .....	15
7-9. Greasing of friction parts .....	16
7-10. Hammer knife .....	17
8. Troubleshooting .....	18~23
8-1. Engine trouble .....	18~19
8-2. Traveling system trouble .....	20
8-3. Hammer knife trouble .....	21~22
8-4. Overheating .....	23
8-5. Step trouble .....	23
9. Checklist .....	24

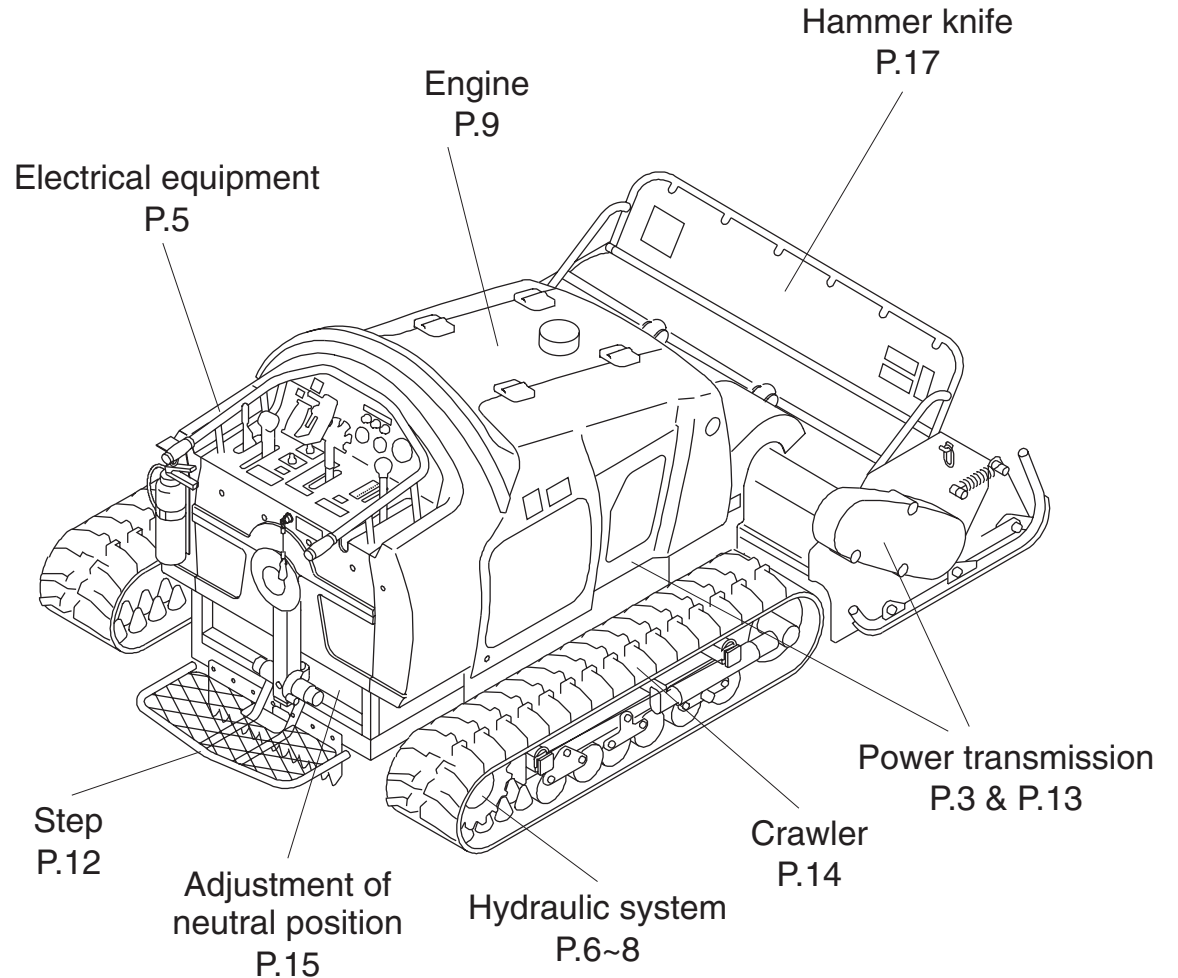

# 1. Specifications

		HMA1560	HMA1720
Dimensions	Total length	3,000mm(3,200mm Foot step)	
	Total width	1,717mm	1,910mm
	Total height	1,350mm	
Engine		Mitsubishi Diesel S4L2-E231KM 1.758L (1,758 cm <sup>3</sup> )	
		Max. output: 26.5 kW/2,800 rpm (36 PS/2,800 rpm)	
		Fuel tank: 33 L (dm <sup>3</sup> )	
Rubber crawler	30 × 7.2cm(51P)	35 × 7.2cm(51P)	
Speed change (Hydraulic variable speed)		Forward: 0-6.5 km/h	
		Backward: 0-4.5 km/h	
Hammer knife	120 blades	140 blades	
Knife clutch	Belt tension type		
Mowing height	3-28 cm(max. 42 cm)		
Mowing width	154cm	170cm	
	Efficiency	70 are/h (6.5 km/h)	77 are/h (6.5 km/h)
	(Mowing width × Operation speed × 0.7)		
Max. operating inclination	30°		
Ground pressure	16.6kPa	14.6kPa	
Dry weight	1,470kg	1,510kg	
Curb weight	1,535kg	1,575kg	

# 2. Maintenance schedule

○.....Inspection, adjustment, replenishment and cleaning  
 ●.....Replacement

Maintenance		Before use	10hrs	every 50hrs	every 200hrs	every 500hrs	Page	
Engine	Engine oil	Initial	●				9	
		After 10 hr	○					
	Oil filter			●			9	
	Fuel filter			○	●		10	
	Electromagnetic pump filter			○	●		10	
	Air cleaner element	○			●		11	
	Air cleaner urethane	○					11	
	Cooling water (qty, leakage, etc.)	○		●			10	
	Fuel (qty, leakage, etc.)	○					10	
	Main unit	Hydraulic oil (qty, leakage, etc.)	○				●	8
Hydraulic oil filter						●	8	
Tightening of hydraulic hose/joint		○					-	
Hydraulic motor oil		Initial			●			8
		After 200 hr				●		
Electrolyte		○					11	
Radiator core		○					10	
Side brake		○					-	
Traveling lever		○					-	
Neutral position		○					15	
Emergency switch operation		○					-	
Step operation		○					12	
Operation of respective switches and meters		○					-	
Lighting of pilot lamp		○					-	
Knife tension operation		○					-	
Strength of knife tension		○					13	
V-belt tension	○					13		
Crawler tension	○					14		
Knife section	Breakage of hammer knife	○					17	
	Looseness of knife mounting bolt	○						
	Knife shaft bearing	○				●		
	Dust-proof cover and protection plate	○						
Others	Greasing each section			○			16	
	Looseness of screw in each section	○					-	
	Accumulation of dust	○					-	
	Visible damage	○					-	

※Repair or replace the abnormal part immediately irrespective of the above schedule.

### 3. List of major power transmission parts

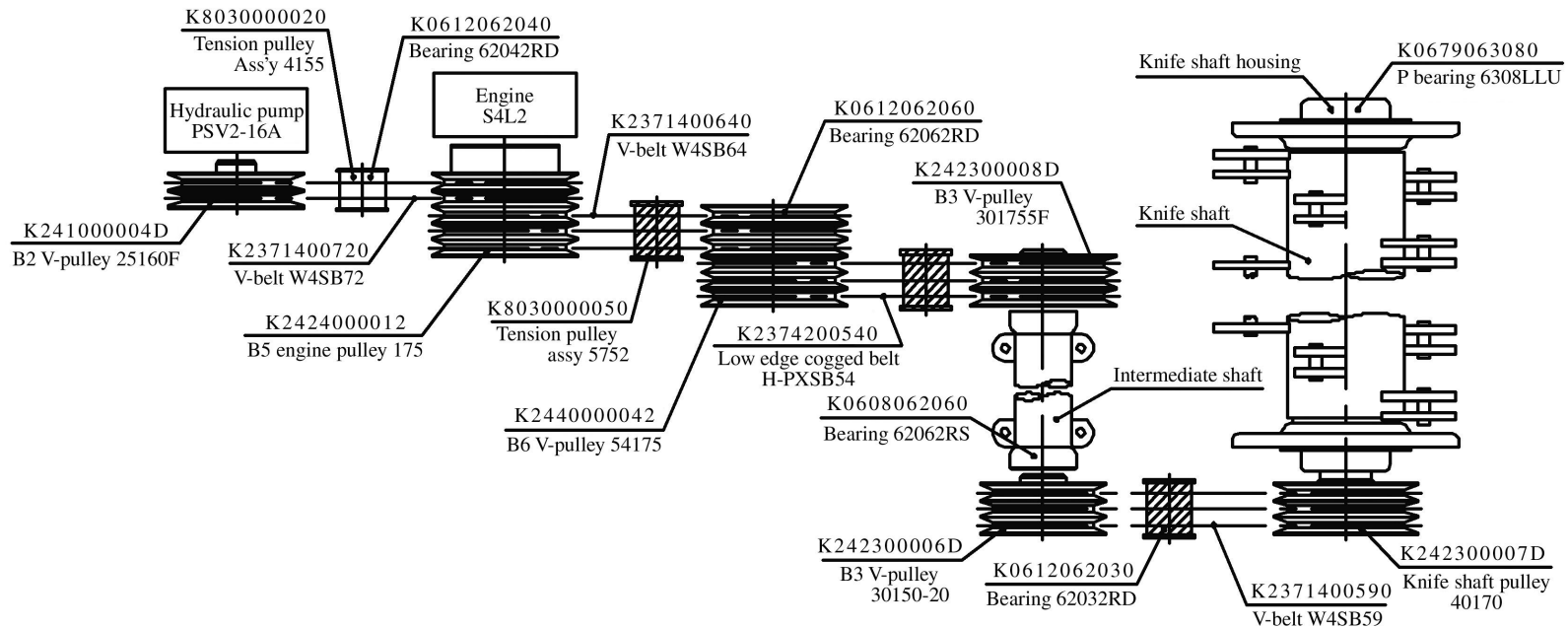
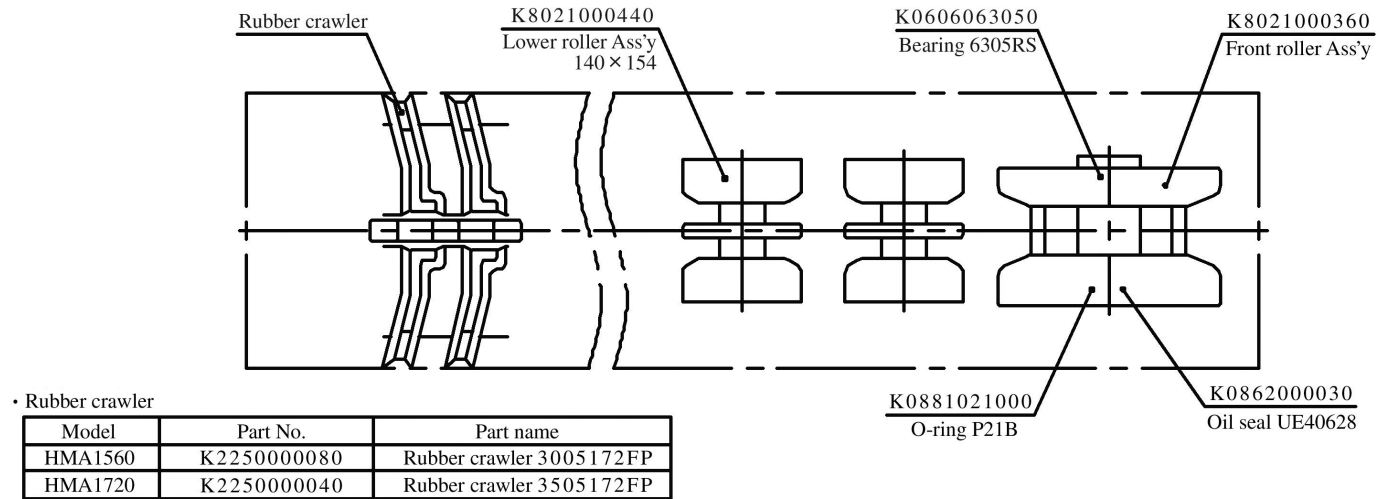

# 4. Wiring diagram

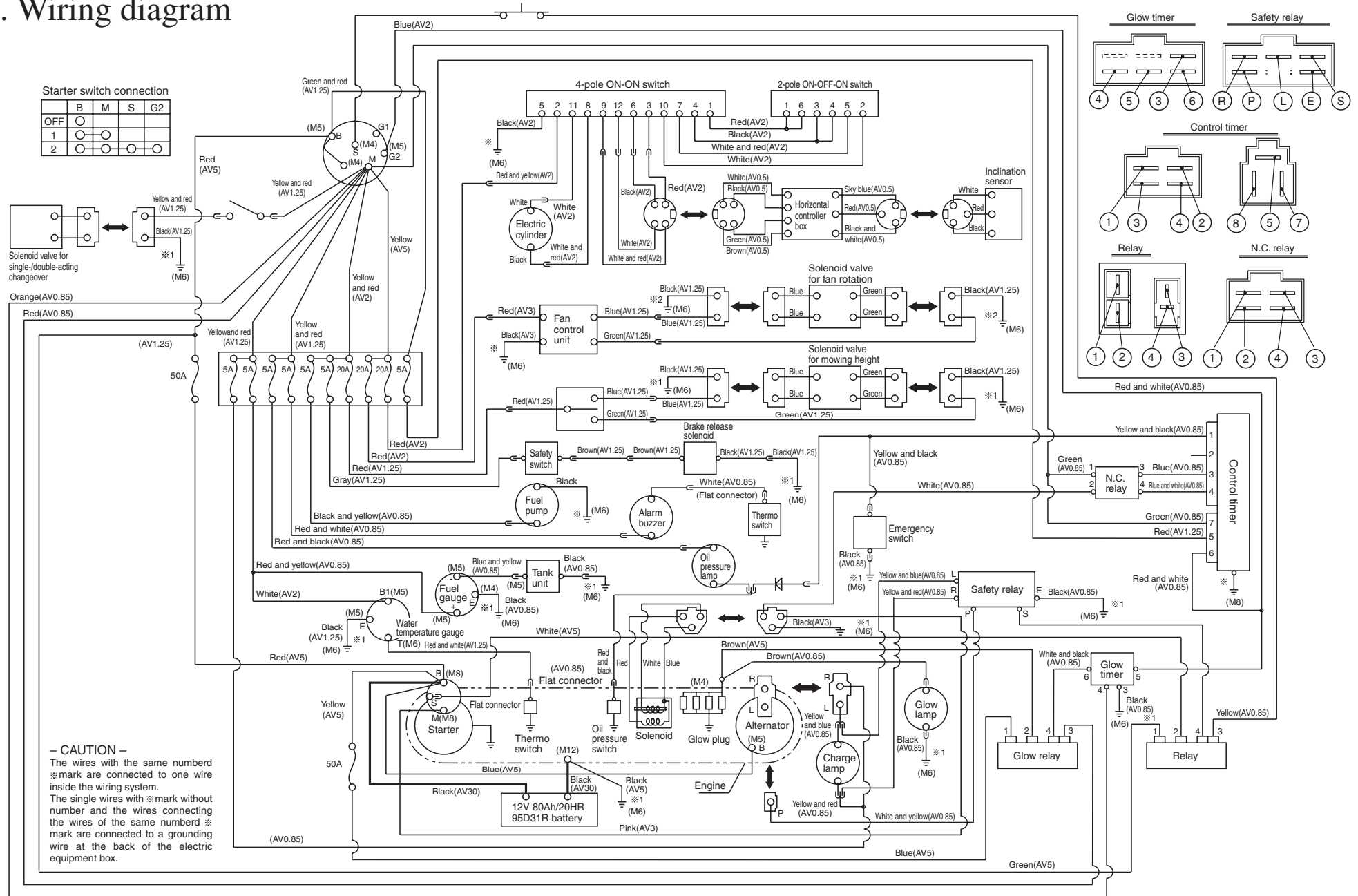

## 5. Electrical equipment

### 5-1. Electrical equipment box

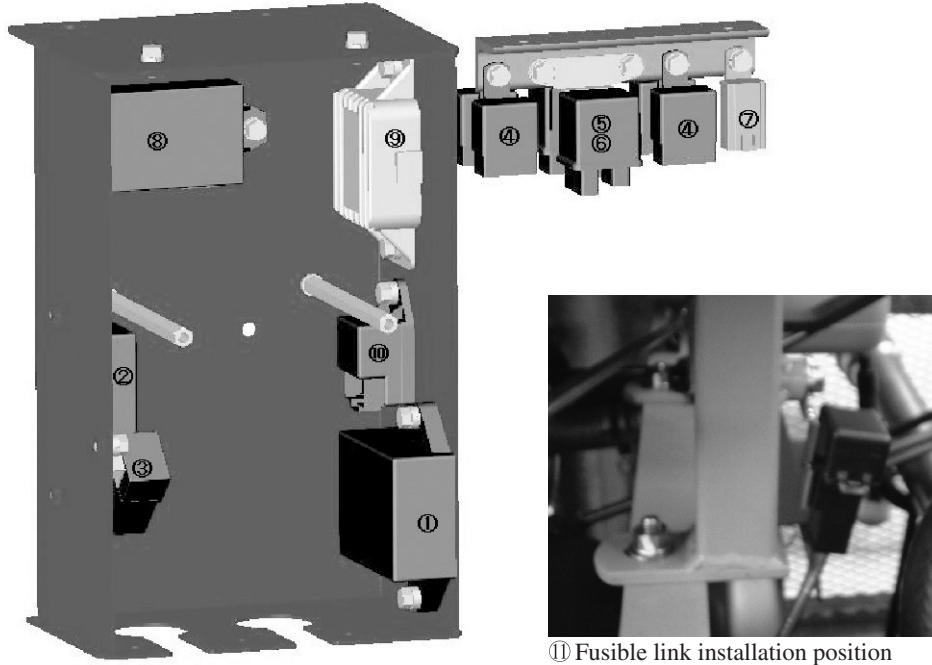

No.	Part name	Application
1	Horizontal controller box	Horizontal control of step
2	Fan control unit	Control of direction of cooling fan rotation
3	Fusible link	Main fuse of electric circuit (50A)
4	Relay	Step control × 2 ; fan control × 2
5	Glow relay	Relay for engine glow relay
6	Starter relay	Engine starting relay
7	Relay	Fuel shutoff solenoid relay
8	Control timer	Control of electric circuit of engine
9	Safety relay	Emergency stop relay
10	Glow timer	Engine glow control
11	Fusible link	Engine glow fuse (50A)

### 5-2. Fuse box

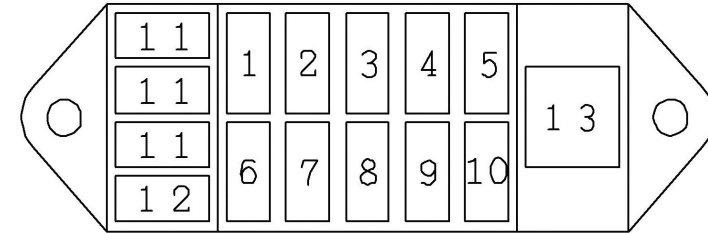

No.	A	Location
1	5	Alarm buzzer
2	5	Oil pressure lamp
3	5	Fuel gauge and water temperature gauge
4	20	Step changeover switch
5	20	Fan control unit
6	5	Control timer unit
7	5	Charge lamp
8	5	Safety switch
9	5	Solenoid valve
10	5	Fuel pump
11	5	Spare fuse
12	20	Spare fuse
13	-	Fuse puller

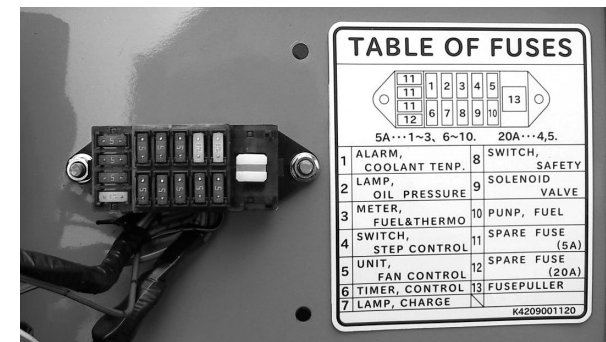

## 6. Hydraulic circuit and equipment

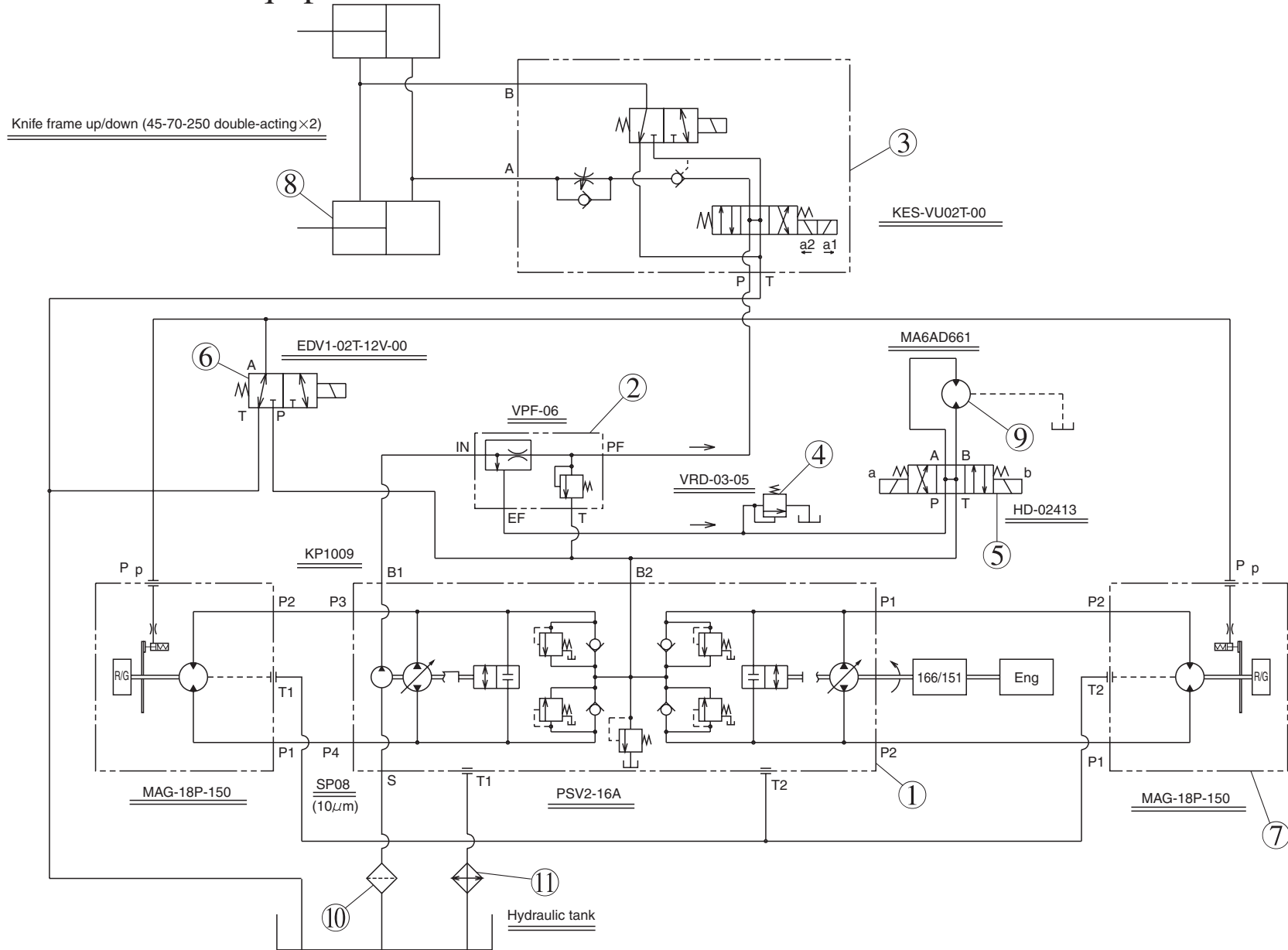

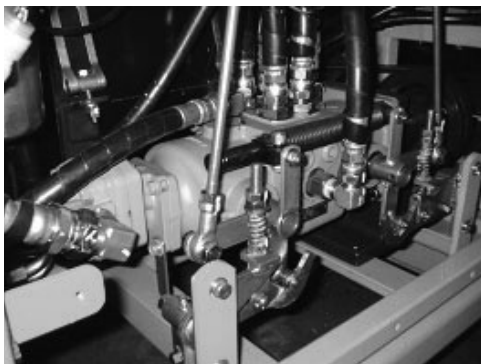

① Hydraulic pump  
Traveling piston pump  
+  
Hydraulic equipment driving gear pump

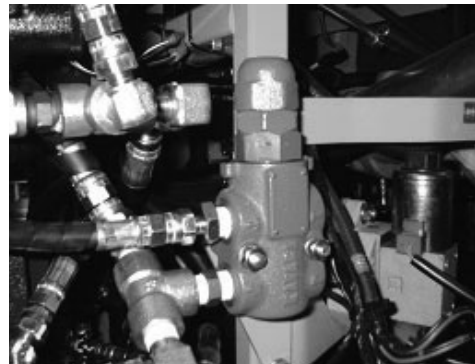

④ Relief valve  
Protection of gear pump

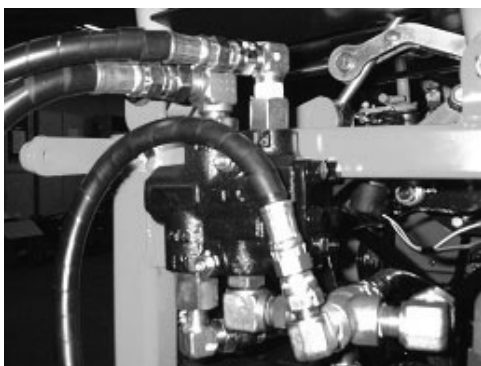

② Flow priority  
Flow dividing valve  
(flow volume control valve)



⑤ Solenoid valve  
Control of direction of cooling fan rotation

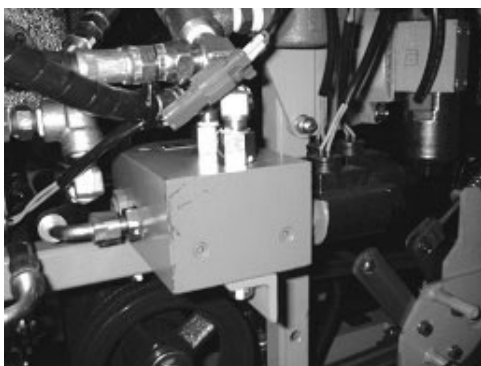

③ Valve unit  
· Mowing height adjustment control  
(Up/down of hammer knife)  
· Single-double changeover of hydraulic cylinder



⑥ Solenoid valve  
Control of brake in traveling motor

⑦ MAG motor : Traveling motor

⑧ Hydraulic cylinder : Up/down of hammer knife

⑨ Gear motor : Cooling fan motor

⑩ Oil filter : Removal of contamination and impurities

⑪ Oil cooler : Cooling unit

## 7. Maintenance of each part

### 7-1. Hydraulic system



A. Hydraulic tank

The tank is at the front of the center of the machine. The oil filler port and oil level gauge are at the left side of the machine.

Remove the seal of the oil filler port, and carefully supply hydraulic oil so that dust or other impurities will not enter.

Hydraulic oil : Shell Tellus ST46



B. Hydraulic tank drain

The drain is at the bottom of the right side of the hydraulic tank. The drain plug itself has no sealing function. Be sure to apply seal tape.



C. Oil filter

It is at the left side of the back of the machine.

※ Refer to “6. Hydraulic circuit and equipment.”



D. Traveling motor (MAG motor)

0.35 L of gear oil is in the speed reducer of the traveling motor. Change oil after 50 hr of initial operation and every 200 hr thereafter.

Gear oil : VG140

(Supplement) Direction of port when changing gear oil

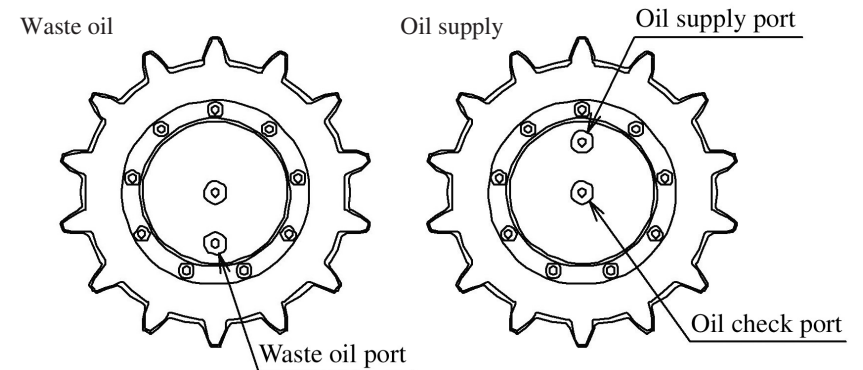

## 7-2. Engine



### A. Engine oil change

Drain engine oil through the drain hose near the crawler at the left side of the machine.

Keep the drain hose inserted in the holder usually when engine oil change is not necessary.



### B. Engine oil supply

Supply engine oil through the oil filler port atop the engine. Use the accompanying funnel to supply oil.

- Engine oil specification  
API standard: Grade CC or above
- Quantity of engine oil  
7.9 L



### (Supplement) Actual oil supply

Clean the machine to prevent dust from entering the engine before oil supply.

※ The photo shows the condition when the left side cover is removed.

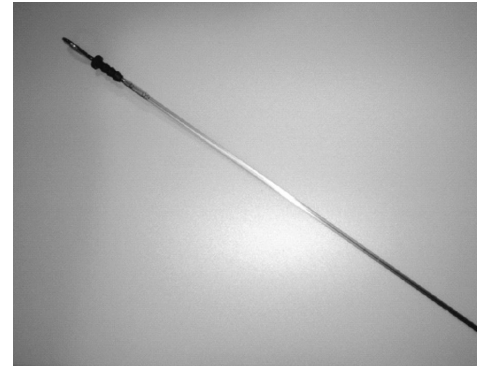

### C. Engine oil gauge

A saber type oil gauge is used for the machine.

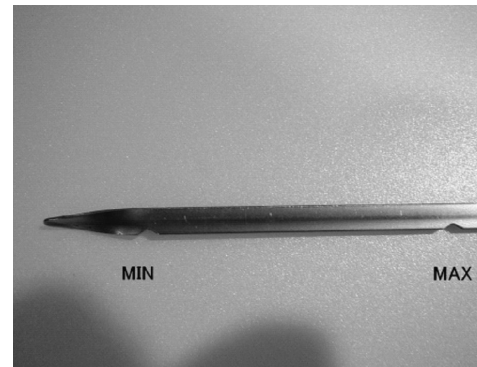

### D. Engine oil quantity

Be sure to check the oil quantity when changing or supplying oil.

The machine is to be operated on a slope as well, so supply oil to the maximum.

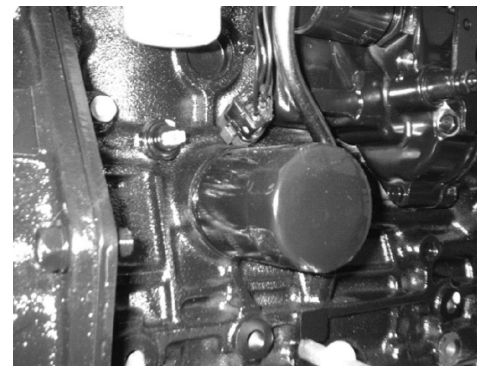

### E. Oil filter

The oil filter is at the front side of the engine (between the engine and hydraulic oil tank).

Before changing the oil filter, stop the engine and cool it sufficiently.

### 7-3. Fuel system/radiator

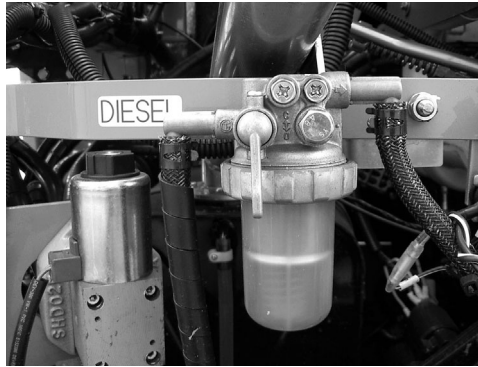

A. Water sedimenter  
Primary fuel filter

When the red float at the bottom of the cup rises, water is mixed with the fuel. Change the whole quantity of the fuel.



B. Fuel pump  
Fuel supply electromagnetic pump  
+  
Secondary fuel filter



C. Exploded view of fuel pump  
There is a filter also in the fuel pump. Unlike other filters, this filter cannot be checked from outside. Exercise care.

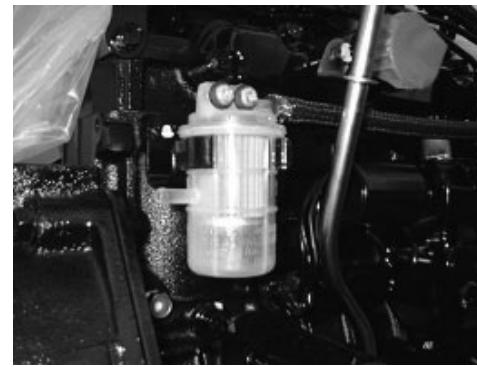

D. Fuel filter  
Tertiary fuel filter

Air bleeding is automatically conducted by the engine itself, but when air bleeding is incomplete, bleed air with the bolt atop the filter.

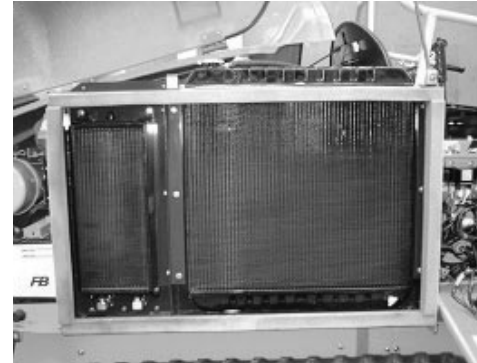

E. Radiator

It is at left side of the machine.  
(Right side of photo)

High-pressure cleaning will damage the heat sink, reducing the cooling effect.

Low-pressure air blowing is recommended.



F. Reserve tank

It is at the right side of the machine.

The volume of water is approx. 11 L in the circulation section, and it is approx. 0.8 L in the reserve tank.

Adjust the quantity of coolant according to the environment.

## 7-4. Air cleaner/battery

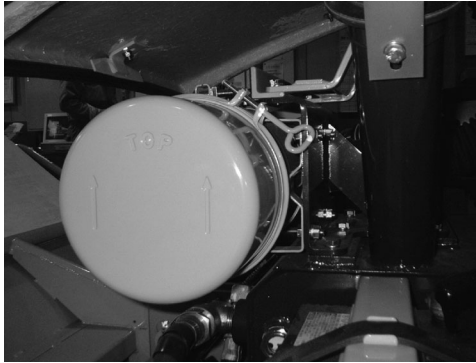

A. Air cleaner

It is atop the hydraulic tank at the front of the machine. The cover is at the left side of the machine.

Pay attention to the installation direction of the cover.

Be sure to stop the engine before maintaining the air cleaner.

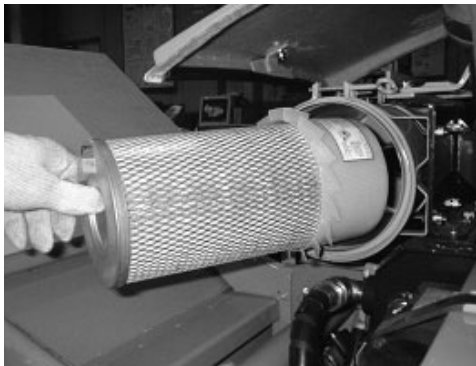

B. Air cleaner element

Remove the cover and wing bolt, and the element can be removed.

When the filter is extremely dirty or broken, change it immediately.



C. Air cleaner cap

It is at the center of the top of the machine.

A cleaner cover and urethane for the cleaner are provided for dust control.



D. Cleaner cover and urethane

The air cleaner cap consists of these parts shown in the photo.

Check that the machine is in the condition shown in Photo C before mowing operation.



E. Battery

It is at the front of the radiator box at the left side of the machine.

Be sure to remove the grounding wire (-) before maintaining the electrical equipment.

## 7-5. Step



### A. Step

It is a simple riding unit provided at the back of the machine.

The electric cylinder is at the right side of the disc at the center.

※ The photo shows the step without the cover.



### B. Step operation switch

- Step control changeover switch  
(Photo: Top)

AUTO :

The step automatically swings according to the angle of inclination.

MANUAL :

Use the switch shown at the bottom of the photo to swing the step.

- Step control manual switch  
(Photo: Bottom)

Manual operation switch to be used when the switch shown at the top of the photo is set in the “MANUAL” position.

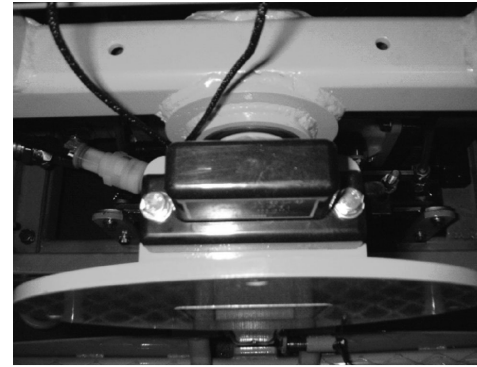

### C. Horizontal sensor

(Analog sensor, Slope Eye 30)

It is at the front of the disc at the center.

This horizontal sensor senses the angle of inclination.



### D. Horizontal controller box

It is in the lower section of the back inside the electrical equipment box.

The signal from the horizontal sensor is transmitted to the electric cylinder.

※ Refer to “5. Electrical equipment.”

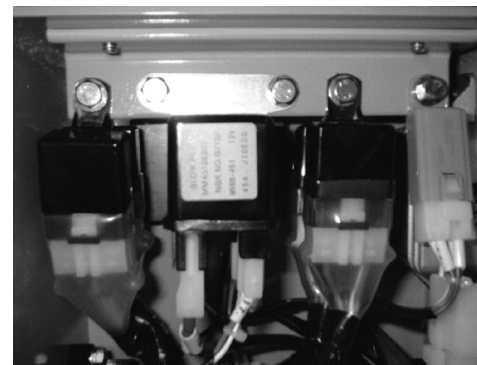

### E. Relay

(Two relays - front and back - at the far left of the photo)

External relays for the horizontal controller box

※ Refer to “5. Electrical equipment.”

## 7-6. Belt adjustment

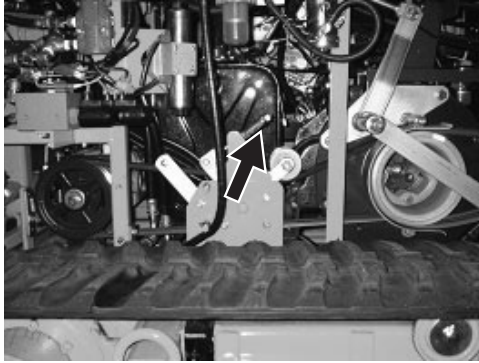

A. Engine pulley ~ Hydraulic pump  
(V-belt W4SB72 × 2 pcs)  
Adjust the hydraulic tension bar spring.

※ Appropriate spring length : 52-55 mm

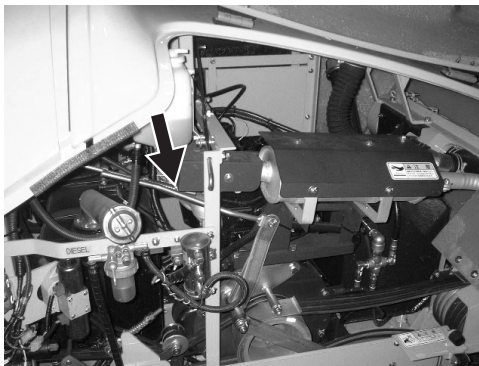

B. Engine pulley ~ Sextuple pulley  
(V-belt W4SB64 × 3 pcs)  
Adjust the knife tension rod spring.

※ Appropriate spring length : 52-55 mm

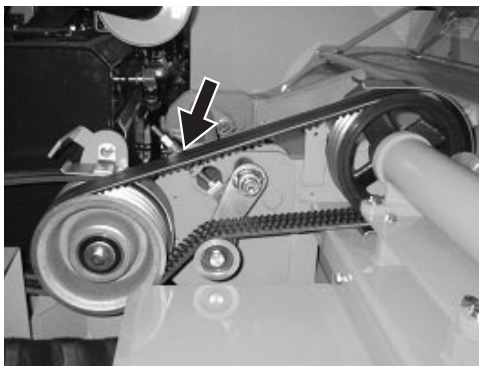

C. Sextuple pulley ~ Intermediate shaft pulley  
(Low-edge cogged belt H-PXSB54 × 3 pcs)  
Adjust the tension lever spring.

※ Appropriate spring length : 47-50 mm

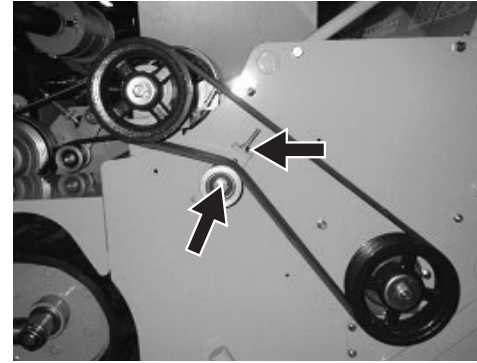

D. Intermediate shaft pulley ~  
Knife shaft pulley  
(V-belt W4SB59 × 3 pcs)

1. Adjust the tension pin and M8 nut at the tension pulley adjusting bolt section.

Loosen the tension pin and tighten M8 nut , and the belt will be stretched.

After adjustment, be sure to tighten and secure the tension pin.

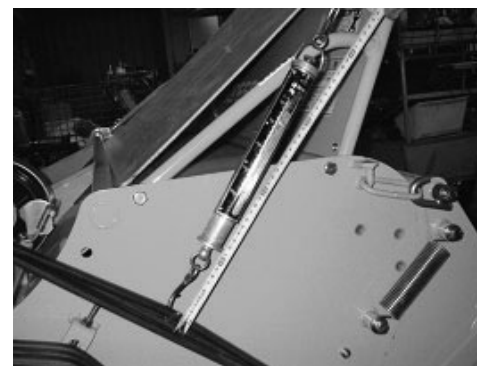

2. Measurement of belt tension  
(Reference)

Pull the center of the belt between pulleys with a spring scale.  
Check the tension by the belt pulling force and the quantity of belt distortion.



3. Belt tensions (Reference)

Appropriate values

Belt pulling force : 5 kg  
Qty of belt distortion : 20 mm

※ The circumferential length of the V-belt changes according to the time and environment of use.  
Try to keep appropriate tension at all times.

## 7-7. Adjustment and detachment of rubber crawler

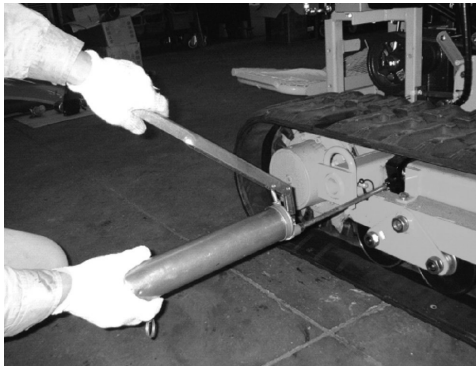

A. Stretching the rubber crawler

Supply grease to the grease nipple of the grease cylinder at the back of the rubber crawler to tension the crawler.

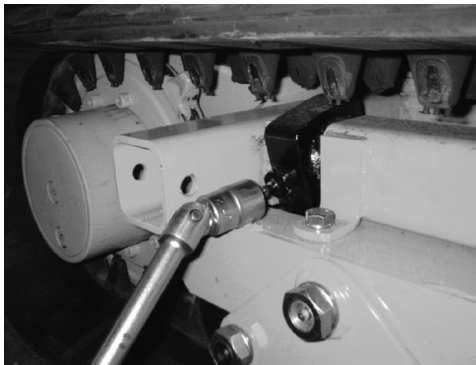

B. Loosening the rubber crawler

1. Loosen the bolt (width across flats: 22 mm) on the grease nipple.



2. Grease will leak from the loosened bolt section, and the rubber crawler will be loosened.

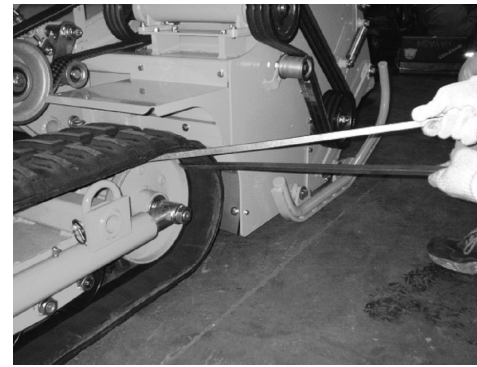

C. Detaching the rubber crawler

After loosening the rubber crawler, jack up the machine and lift the rubber crawler above the ground. Remove the front portion of the crawler first. It is convenient to use a long crowbar shown in the photo.

When attaching the crawler, fit the sprocket side first, and then fit the front roller side.

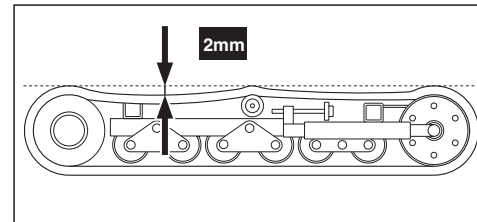

D. Adjustment of the rubber crawler tension

Refer to the figure at left, and adjust the tension.

※ Looseness or excessive tension will cause the rubber crawler to come off.

E. Configuration of rubber crawler parts

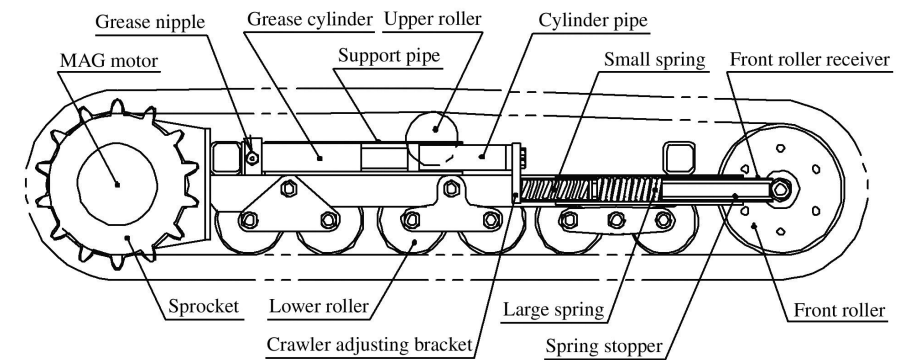

## 7-8. Adjustment of the neutral position of piston pump

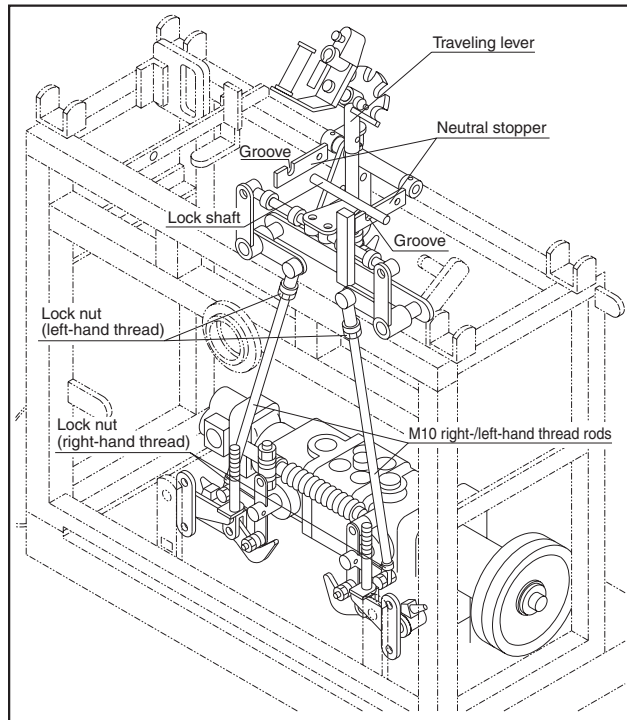

Fig. A

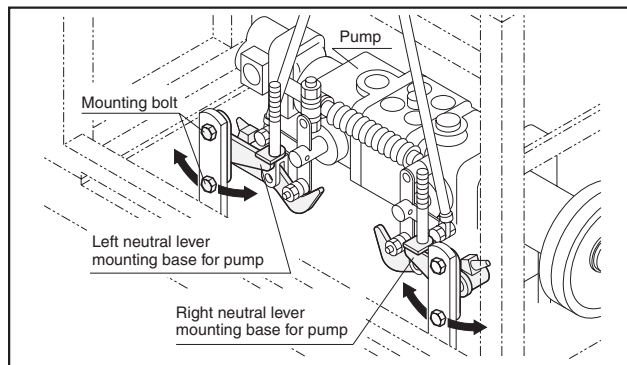

Fig. B

### A. Adjustment of neutral position

- When the machine will not stop even if the traveling lever is released, adjust the neutral position in the manner shown below.
  - ① Secure the machine so that the rubber crawlers at right and left will be lifted above the ground, and release the side brake. (When the rubber crawler is out of place, lift the sprocket above the ground.)
  - ② After loosening the mounting bolts (Fig.B), start the engine and move the neutral lever right and left to find the neutral position.
    - ※ The engine is running. Be careful of the rotating parts and hot parts.
  - ③ When the neutral position is found, tighten the mounting bolts, and recheck that the machine is in the neutral position. Adjustment of the neutral position is finished.
  - ④ Then while keeping the machine in the neutral position, pull the side brake and make adjustment so that the lock shaft of the traveling lever is set in the grooves of the neutral stopper. (Fig.A)
  - ⑤ Loosen the lock nuts of the M10 rods at right and left. (Fig.A: 4 locations in total)
  - ⑥ Rotate the rods to adjust the length of them and make adjustment so that the lock shaft will be set naturally in the grooves.
  - ⑦ Confirm appropriate setting of the lock shaft and grooves by repeat of lock and unlock of the side brake several time.
  - ⑧ After adjustment, tighten the lock nuts and check again the locational relationship between the lock shaft and grooves.

Now all the processes are finished.
- If the side brake cannot be pulled (the lock shaft and grooves are not in position) although the machine is at rest when the traveling lever is released, continue operations from ④.

### B. Q&A about neutral position

Q : What will happen when the neutral position is not correct?

A : Even if the operation lever is released in an emergency, the machine will not stop, which is very dangerous.

Q : What will happen when the lock shaft and groove are not in position.

A : You cannot pull the side brake, and you cannot park the machine correctly. When you pull the side brake forcibly and align the lock shaft with the grooves by force, the traveling machine will be forcibly stopped by the brake; therefore, the relief valve will be activated, raising the oil temperature suddenly.

When the oil temperature rises, the hydraulic equipment will be damaged.

## 7-9. Greasing of friction parts

Apply grease to respective joints in good time to prevent rusting.  
Supply grease every 50 hours to grease nipples.

### A. Greasing section

- Crawler section [26 locations]

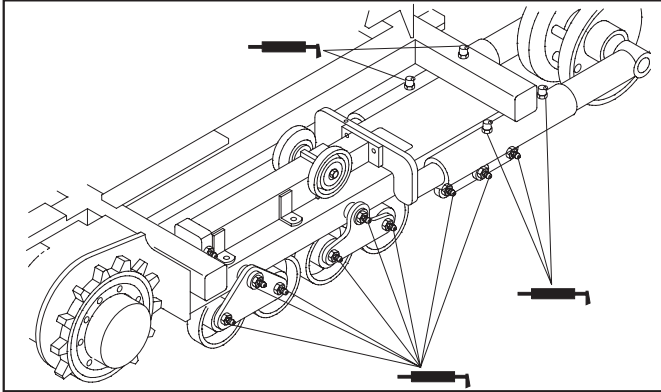

- Tensioning section [3 locations]

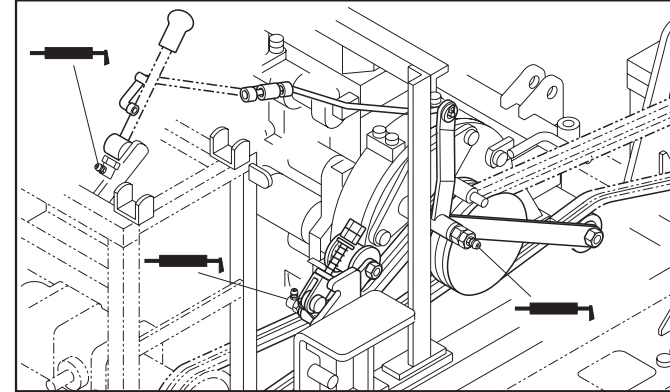

- Operation lever & parts relating to the neutral position [8 locations]

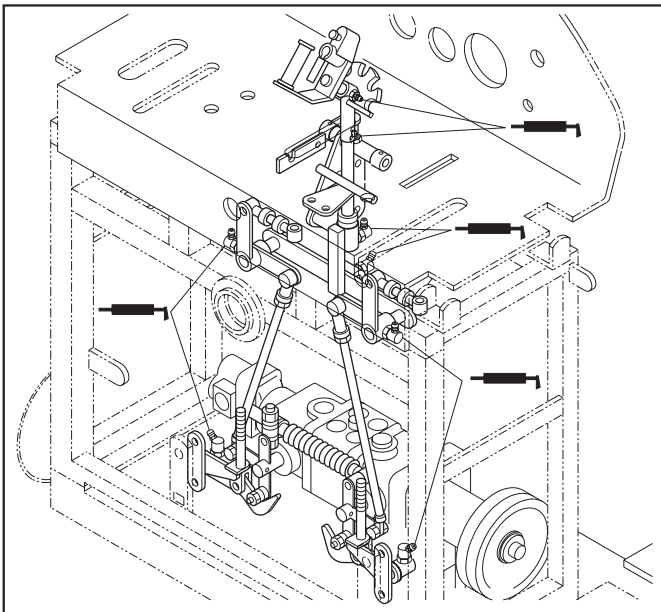

- Knife frame support [2 locations]

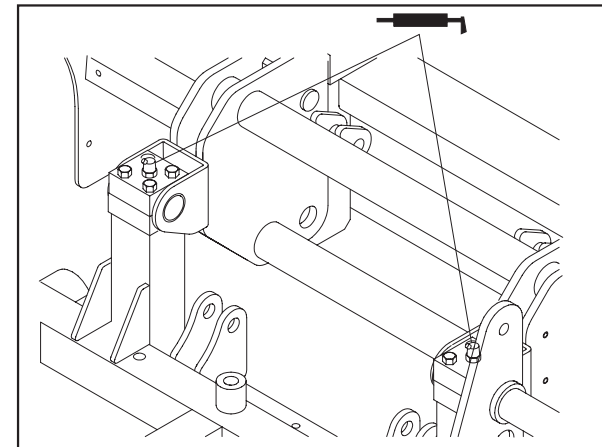

- Both sides of knife shaft [2 locations]

Greasing of both ends of the knife shaft is not for lubrication but for protection (waterproofing and dustproofing) of the bearing.

Exercise care so as not to apply pressure when greasing.

## 7-10. Hammer knife

The knife shaft is rotating at high speed, and slight loss of balance will cause substantial vibration. Machine operation with loss of balance may cause an unexpected accident or failure. Maintain the knife shaft most carefully.

### A. Maintenance of knife shaft

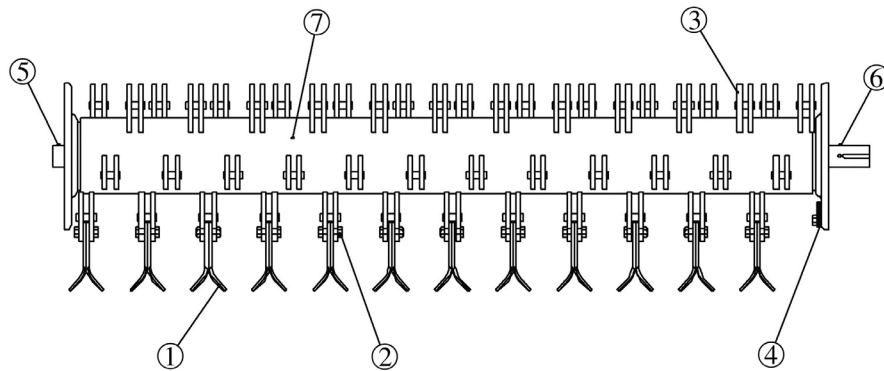

No.	Part	Inspection item	Correction
1	Knife blade	Missing blades	Attach.
		Breakage, curvature, or uneven abrasion	Replacement
2	Mounting pin	Wrong direction	Attach correctly.
		Looseness	Tightening (*1)
3	Mounting hitch	Curved or open	Correction
		Breakage or uneven abrasion	Repair or replacement (*2)
4	Balance weight	Missing	Repair by specialist (*2)
		Abrasion	
5	Support shaft	Uneven abrasion	Repair or replacement by specialist (*2)
6	Bearing	Unsmooth rotation	Replacement
7	Knife shaft	Twining of vines or cords	Removal
		Distortion as a whole	Replacement

\*1 The tightening torque of the knife mounting pin is 32-36 Nm (equivalent to M10 ordinary bolt). Excessive tightening will damage the thread of the mounting pin.

\*2 Special correction by balancing machine may be required.

### B. Protective device

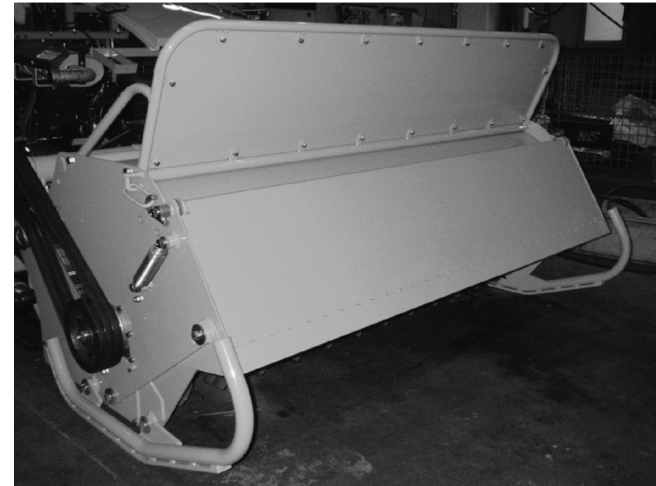

The protection cover, protection plate, and knife guard are protective devices. Attach them correctly before work. Replace them immediately if they are damaged in any degree.

An anti-scattering chain is provided as an option. Use it according to the working environment.

# 8. Troubleshooting

## 8-1. Engine trouble

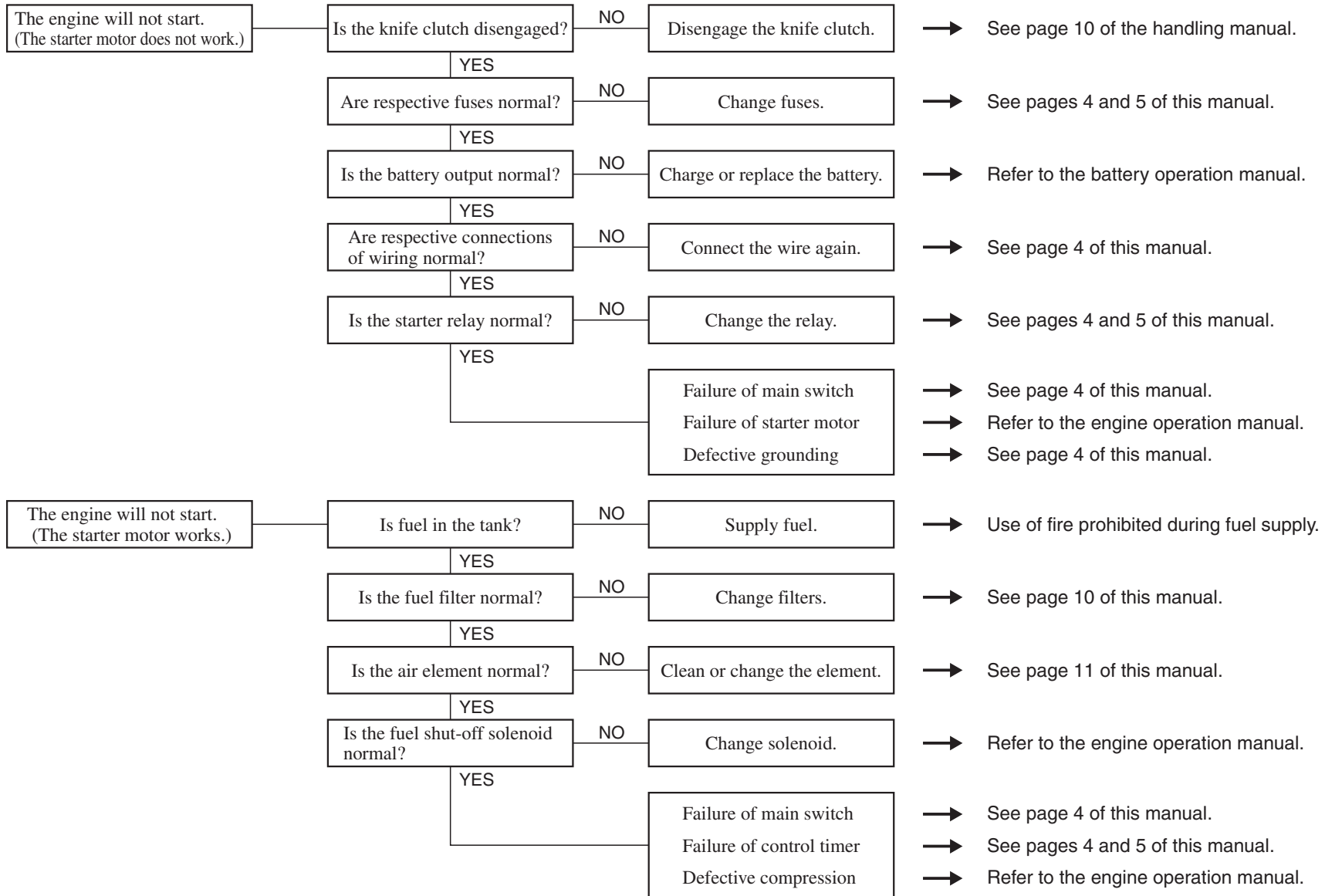

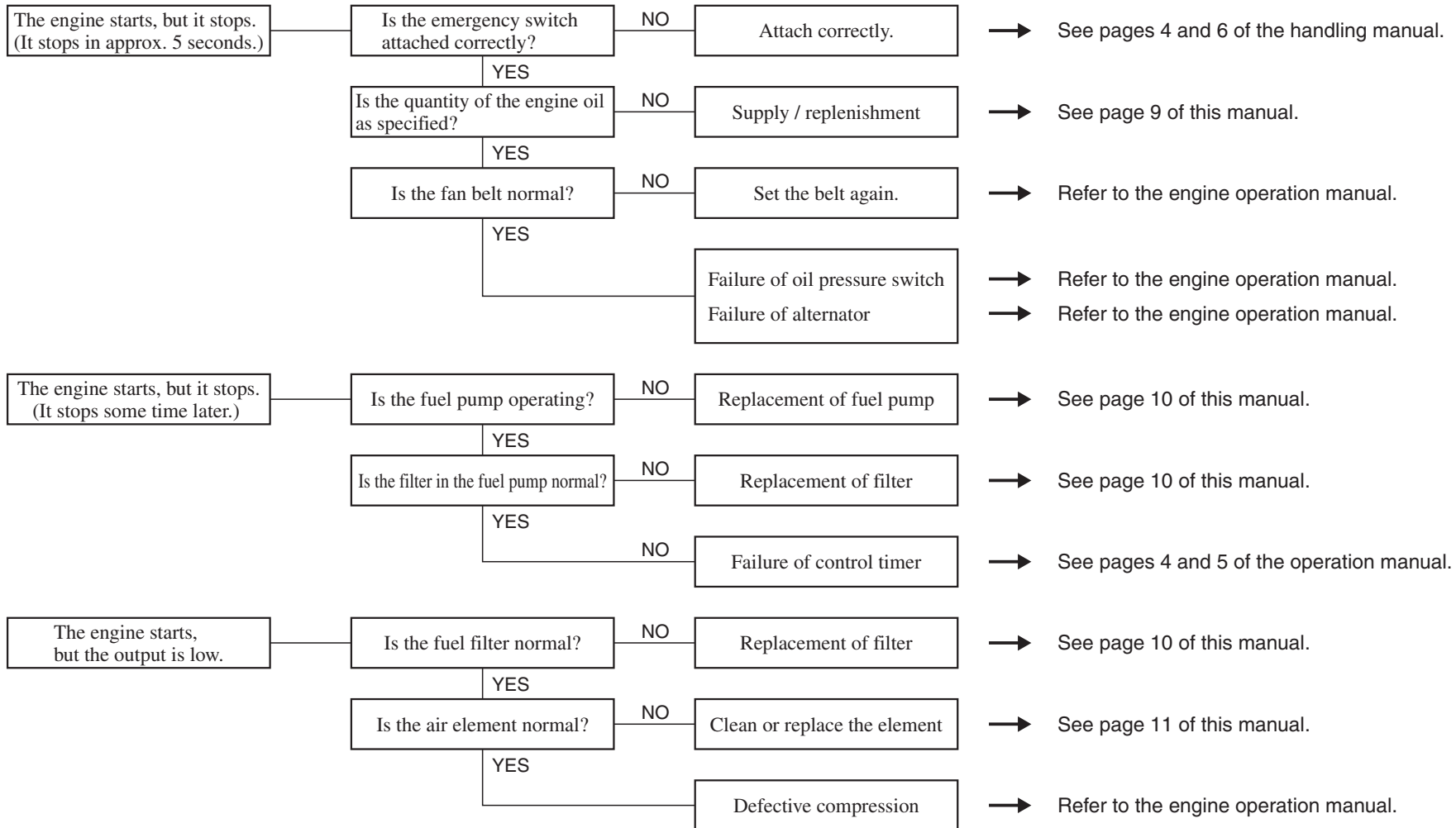

## 8-2. Traveling system trouble

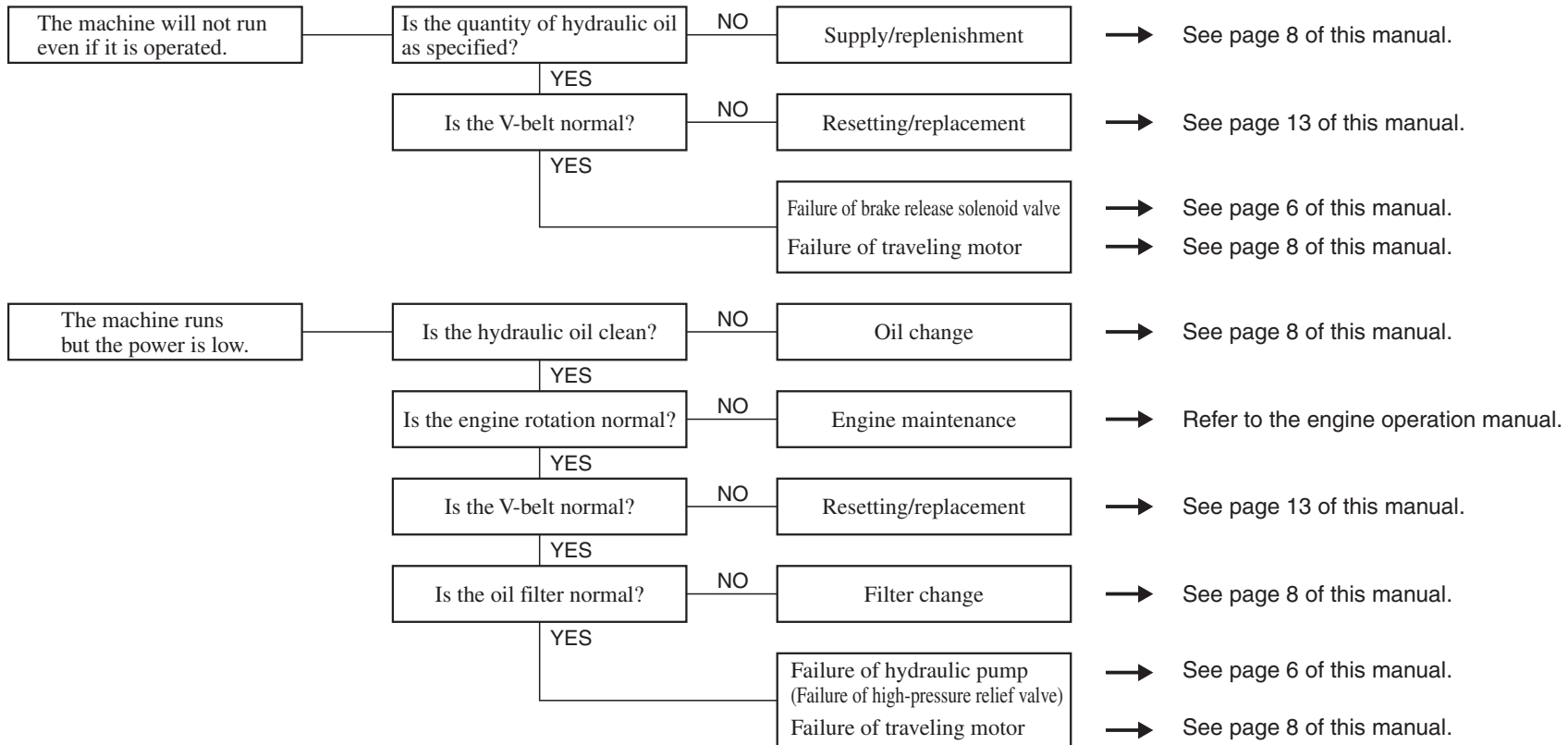

### 8-3. Hammer knife trouble

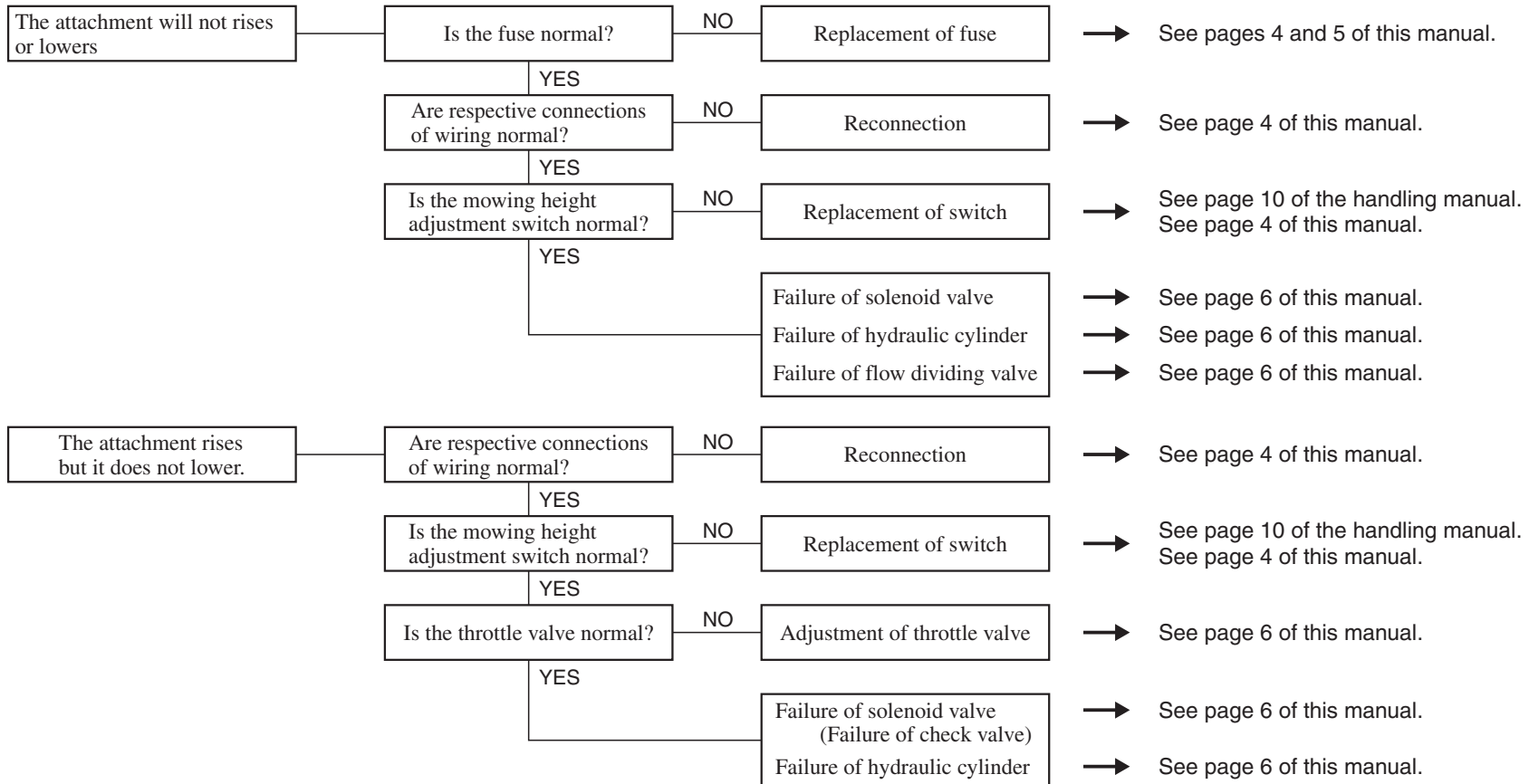

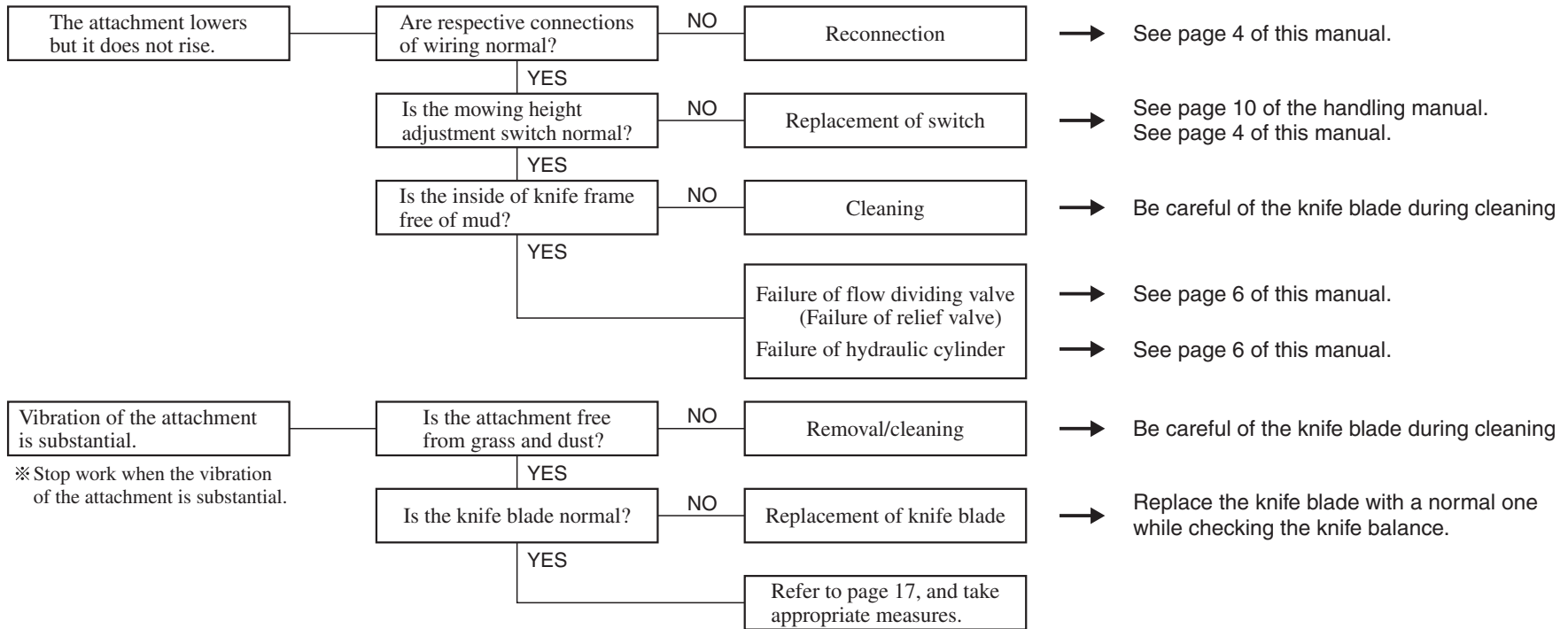

## 8-4. Overheating

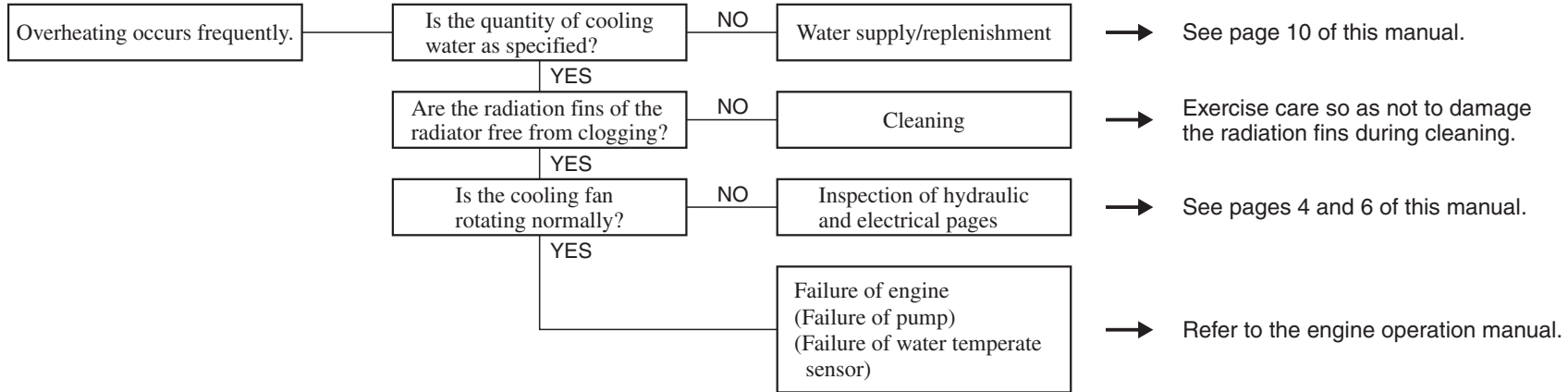

## 8-5. Step trouble

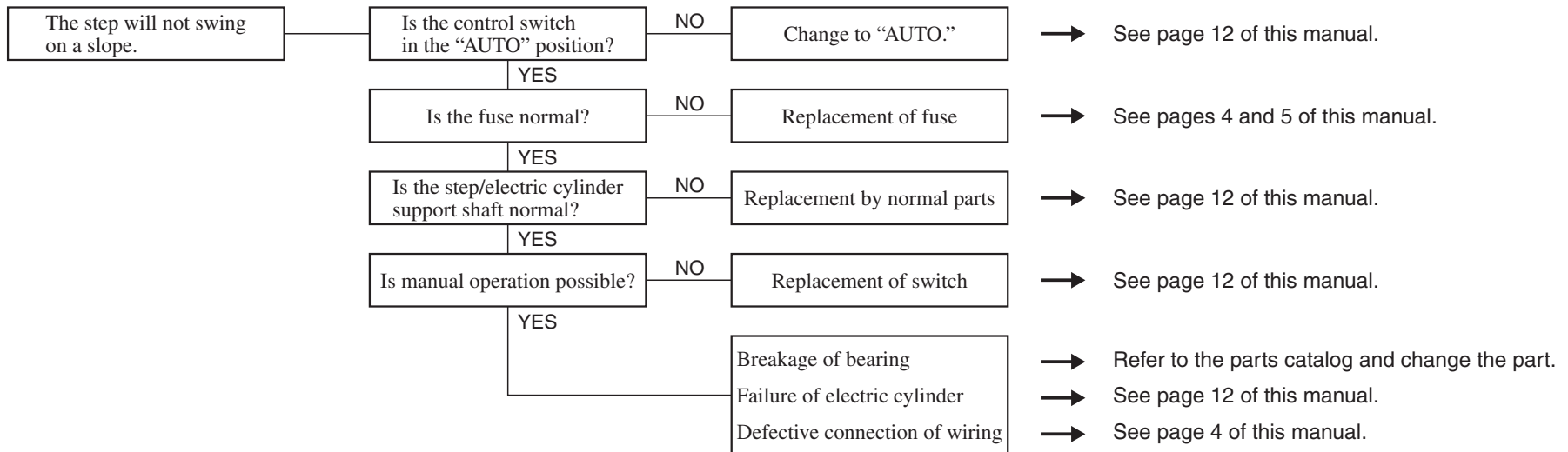

# 9. Checklist

Symbol of judgment . . . . ○ : Normal ; △: Adjustment/correction ; × : Repair/replacement

Model	Machine No.	Operating time	Performance date	Operating time	Performance date	Operating time	Performance date	Operating time	Performance date	Operating time	Performance date	Memo
Item		Judgment	Notes	Judgment	Notes	Judgment	Notes	Judgment	Notes	Judgment	Notes	
Engine (start/color of exhaust/number of revolutions)												
Engine oil (quantity/cleanliness)												
Engine oil filter												
Air cleaner (element/urethane)												
Radiator (cooling water/radiation fin)												
Fan belt tension												
Fuel (quantity/leakage)												
Hydraulic oil (quantity/cleanliness)												
Hydraulic oil filter												
Tightening of hydraulic hose/joint												
Traveling motor gear oil (quantity/cleanliness)												
Battery (qty of electrolyte/connection)												
Operation of operation levers												
Neutral position												
Operation of emergency switch												
Operation of step												
Operation of switches and meters												
Lighting of lamps												
Operation of wires												
Operation of knife tension parts												
Operation of knife tension spring												
Tension of V-belts												
Rubber crawler (tension/damage)												
Condition of rotation of front and bottom rollers												
Balance of hammer knife shaft												
Hammer knife blade (abrasion/breakage)												
Vertical motion of hammer knife												
Damage to protective covers												
Greasing of respective parts												
Loosening of screws												
Accumulation of dust												
Damage to caution label												
Damage to appearance												
		Inspector		Inspector		Inspector		Inspector		Inspector		



 **KYOISHA CO., LTD.**  
Head Office  
1-26, Miyuki-cho, Toyokawa,  
Aichi-Pref. 442-8530 Japan.  
Tel : (0533)84-1221  
Fax : (0533)84-1220