

LM101

Floating Head Greens Mower

Parts catalog

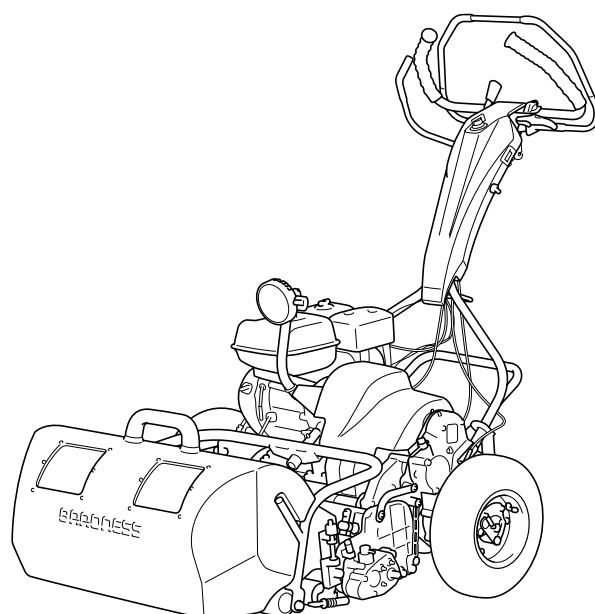

BARONNESS[®]
Quality on Demand

Serial No. LM101 : 10906-

Ver.3.1

Greetings

Thank you for purchasing Baroness product.

This brochure contains the information needed for ordering BARONESS parts.

Search the number indicating the figure of your desired part in the illustration area, and find the same number from among the latter parts of the hyphenated Cat Nos. in the listing area to obtain the individual Code No.

Notes

1) For inquiries of parts

Inform us of the model and the serial number of your machine or attachment.

The model and the serial number are indicated on the serial number plate of your machine or attachment.

* Consult the Owner's Operating Manual for the position where the serial number plate is affixed.

2) For ordering parts

- Inform us of the Code No., Part name and order quantity.
- We do not accept returns unless our company is responsible for the issue.
- Use genuine Baroness parts and accessories. The Baroness product warranty may not apply if parts or accessories from other companies are used.

3) The information described in this brochure is subject to change without prior notice.

Description of the content of Parts catalog

1) Illustration area

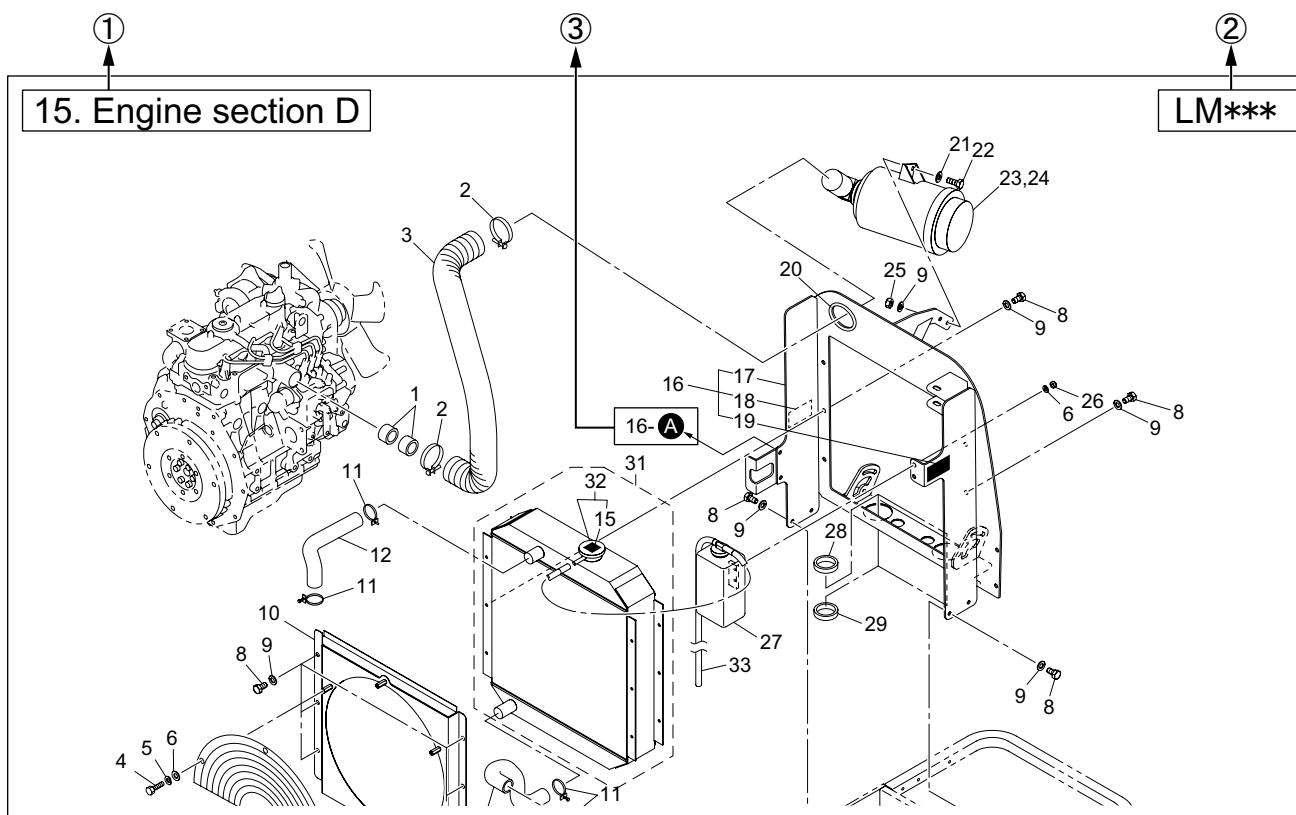

- ① Section No. /Section name
- ② Model
- ③ Indication of the connecting point

The following indication shows the connecting point of the part shown on the other page.

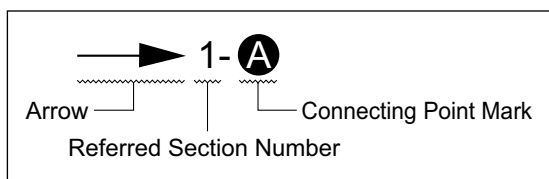

- 1- **A** :
Refer to the point **A** in the illustration of the section No.1
- 2- **B** :
Refer to the point **B** in the illustration of the section No.2

Note :

The figures of assembled components or isolated parts do not always show their accurate shapes. The figures are supposed to be used for obtaining the correct code numbers.

2) Listing area

| ① Cat No. | ② Code No. | ③ Part name | ④ ⑤ Qty | | | ⑥ Remark | ⑦ SN of application |
|--------------|---------------|-----------------------------|------------|---|---|-------------|------------------------|
| | | | | | | | |
| 1 - 1 | K0000080152 | BOLT, M8-15 | 2 | 2 | 2 | | |
| 1 - 2 | K0185160002 | NUT, LEFT-HANDED P1.5 M16-3 | 2 | 2 | 2 | | |
| 1 - 3 | K3650000100 | HOUR METER, HH2AS | 1 | 1 | 1 | | 10001-10023 |
| 1a- 3 | K3650000130 | HOUR METER, 636DC | 1 | 1 | 1 | | 10024- |
| 1 - 4 | K0100060002 | NUT, M6 | 2 | 2 | 2 | | |
| 1 - 5 | K0003080702 | BOLT, M8-70 | 1 | 1 | 1 | | |
| 1 - 7 | K0830000020 | OIL SEAL, 254210 | 2 | 2 | 2 | | |

① Cat No. or Catalog No.

Find the same number as the number indicating the figure of your desired part in the illustration area from among the latter parts of the hyphenated Cat Nos. to obtain the individual Code No.

② Code No.

Identification code of an individual part

③ Part name

④ Qty

Quantity needed per Cat No.

⑤ Model

When the quantity differs by models, the models are indicated.

⑥ Remark

Specification or description, etc. of the part may be indicated.







⑦ SN of application

In case of part alteration, the serial number ranges of machines to which the alteration is applied will be indicated.

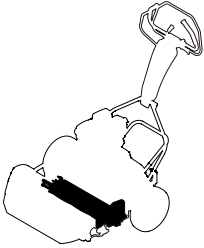
3) Indication in case of part alteration

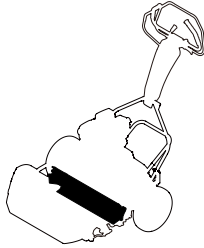
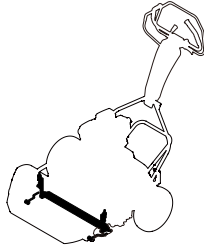
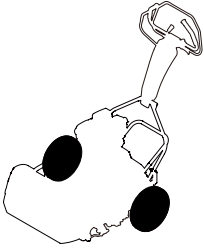
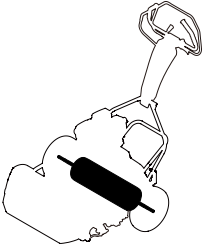
- When a new part and an old one are interchangeable with each other, indication of the old part code No. is discontinued and the new part code No. is solely indicated.
- When a new part and an old one are not interchangeable, the serial number ranges of both machines where the new part is used and those where the old one is used are indicated in the SN of application column.
- When a part is newly added, the serial number range of machines where the part is used is indicated in the SN of application column.
- When a part was previously used but the part is not used in the machine any longer, the serial number range of machines where the part was used is indicated in the SN of application column.

Contents

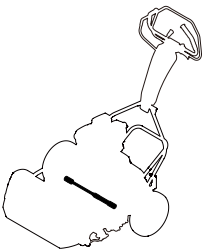
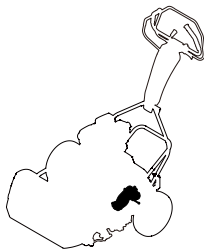
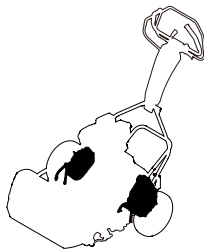
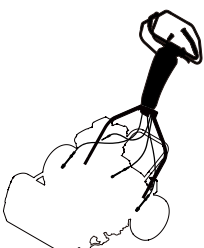
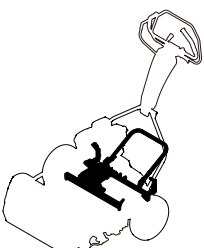
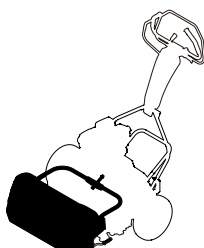
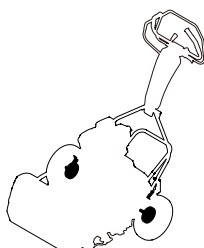
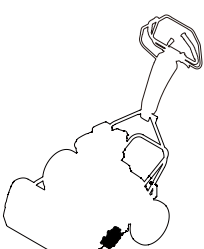
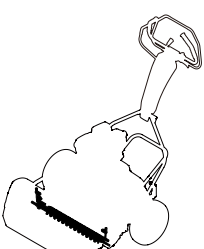
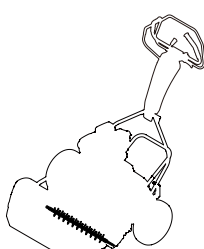
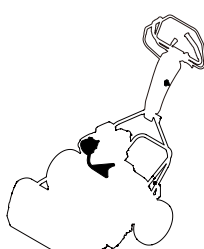
| | | | |
|---|---|---|---|
| <p>1. Cutting section A P1</p>  | <p>2. Cutting section B P3</p>  | <p>3. Cutting section C P5</p>  | <p>4. Cutting section D (Grooved roller) P7</p>  |
| <p>5. Wheel section A (Tire) P8</p>  | <p>6. Wheel section B (Drum) P9</p>  | <p>7. Wheel section C P10</p>  | <p>8. Wheel section D P11</p>  |
| <p>9. Engine & Clutch section P13</p>  | <p>10. Power transmission section (Joint) P15</p>  | <p>11. Mower transmission case section P16</p>  | <p>12. Frame section P18</p>  |
| <p>B13. Handle section C P20</p>  | <p>14. Handle section D P22</p>  | <p>15. Grass catcher section P23</p>  | <p>16. Brake section P25</p>  |
| <p>17. Groomer section A P26</p>  | <p>18. Groomer section B P28</p>  | <p>19. Brush section P30</p>  | <p>20. Light section P31</p>  |

Contents

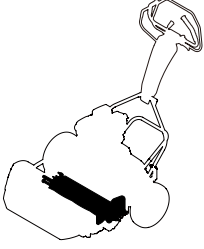
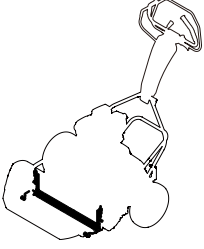
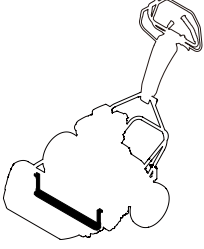
| | | | |
|---|---|----------------------------------|-------------------------------------|
| <p>21. Cutting section A (with Groomer) P32</p>  | <p>22. Cutting section B (with Groomer) P34</p>  | <p>23. Accessories P35</p> | <p>24. Optional tools P36</p> |
| <p>25. Smooth roller KIT ... P37</p>  | | | |
| | | | |
| | | | |
| | | | |

1. Cutting section A

LM101

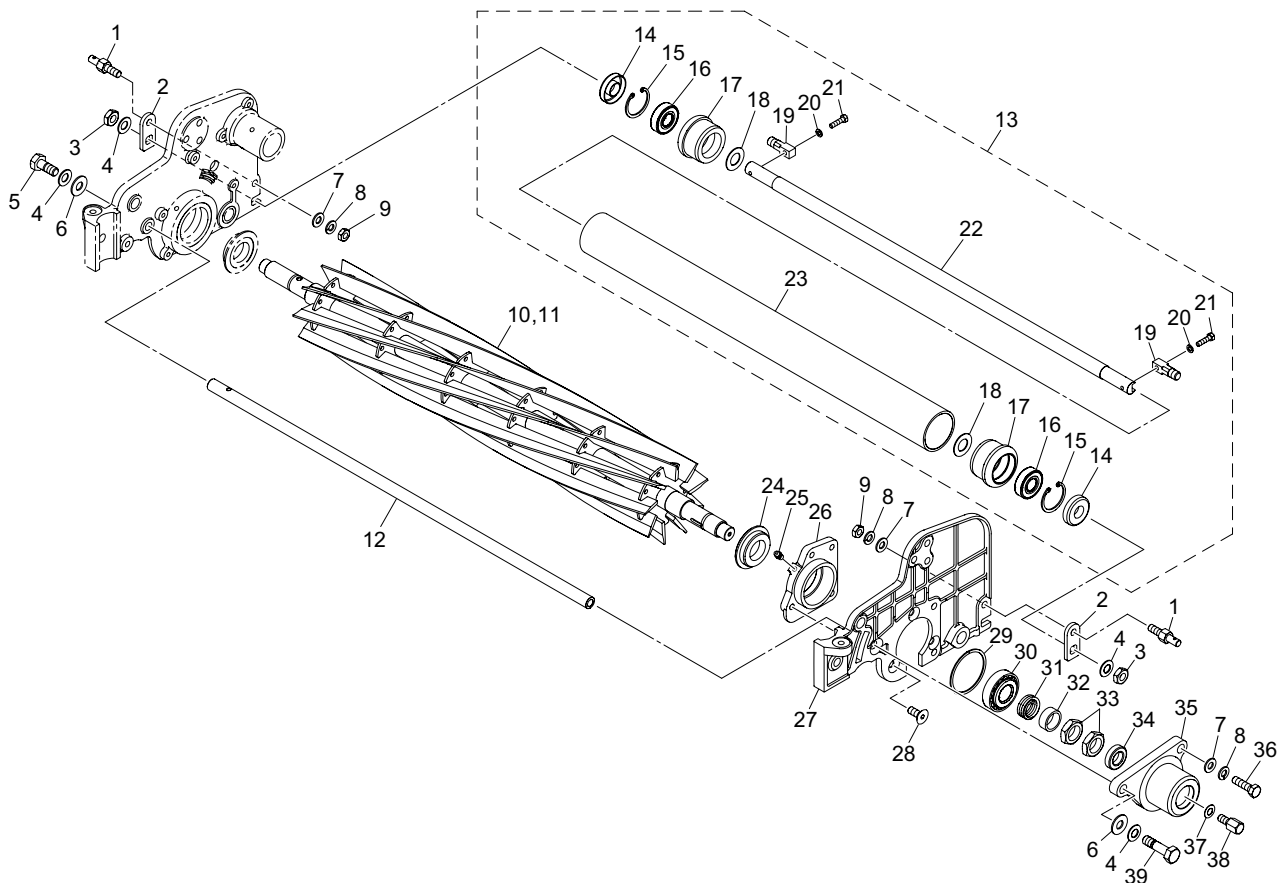

LM101_01_z00

| Cat No. | Code No. | Part name | Qty | Remark | SN of application |
|---------|---------------|-----------------------------------|-----|-----------|-------------------|
| 1 - 1 | LM54GA-0149Z3 | BOLT, 45 | 2 | | |
| 1 - 2 | LM101--0148Z2 | STOPPER | 2 | | |
| 1 - 3 | K0160000282 | NUT, P1 OH1 M10-3 | 2 | | |
| 1 - 4 | K0211100001 | SPRING, CONICAL DISC H M10 | 4 | | |
| 1 - 5 | LM54GA-0115A3 | BOLT, KNOCK 25 | 1 | | |
| 1 - 6 | K5001100002 | WASHER, M10-24 | 2 | | |
| 1 - 7 | K5000080002 | WASHER, M8 | 4 | | |
| 1 - 8 | K0200080002 | WASHER, SPRING M8 | 4 | | |
| 1 - 9 | K0102080002 | NUT, M8-3 | 2 | | |
| 1 - 10 | K280540090R | REEL CUTTER, 557 | 1 | 9 blades | 10470-10905 |
| 1a- 10 | K28054009CR | REEL CUTTER, 557 | 1 | 9 blades | 10906- |
| 1 - 11 | K280540110R | REEL CUTTER, 557-11 | 1 | 11 blades | 10470-10905 |
| 1a- 11 | K28054011AR | REEL CUTTER, 557-11 | 1 | 11 blades | 10906- |
| 1 - 12 | LM54GA-0114A3 | STAY, MOWER 603.4 (FRONT) | 1 | | |
| 1 - 13 | LM101--0153A0 | ROLLER ASSY, REAR | 1 | | |
| 1 - 14 | K0851535080 | OIL SEAL, PJN15358 | 2 | | |
| 1 - 15 | K0402035001 | RING, RETAINING R M35 | 2 | | |
| 1 - 16 | K0612062020 | BEARING, BALL SEAL 2RD 6202 | 2 | | |
| 1 - 17 | LM101--0139Z0 | HOUSING, ROLLER | 2 | | |
| 1 - 18 | K5051015280 | WASHER, C5191P 1-15-28 | 2 | | |
| 1 - 19 | LM101--0140Z2 | SHAFT, M10 | 2 | | |
| 1 - 20 | K0200050002 | WASHER, SPRING M5 | 2 | | |
| 1 - 21 | K0010050202 | BOLT, HT M5-20 | 2 | | |
| 1 - 22 | LM101--0137Z2 | SHAFT, ROLLER | 1 | | |
| 1 - 23 | LM54G--0138Z0 | ROLLER, REAR | 1 | | |
| 1 - 24 | K0830000020 | OIL SEAL, 254210 | 1 | | |
| 1 - 25 | K1440000010 | GREASE NIPPLE, STRAIGHT TYPE A | 1 | | |
| 1 - 26 | LM101--0123ZR | HOUSING, REEL (LH) | 1 | | |
| 1 - 27 | LM101--0103B0 | FRAME, (LH) | 1 | | |
| 1 - 28 | K0053080202 | BOLT, FLAT HEAD W/HEX. HOLE M8-20 | 3 | | |

1. Cutting section A

LM101

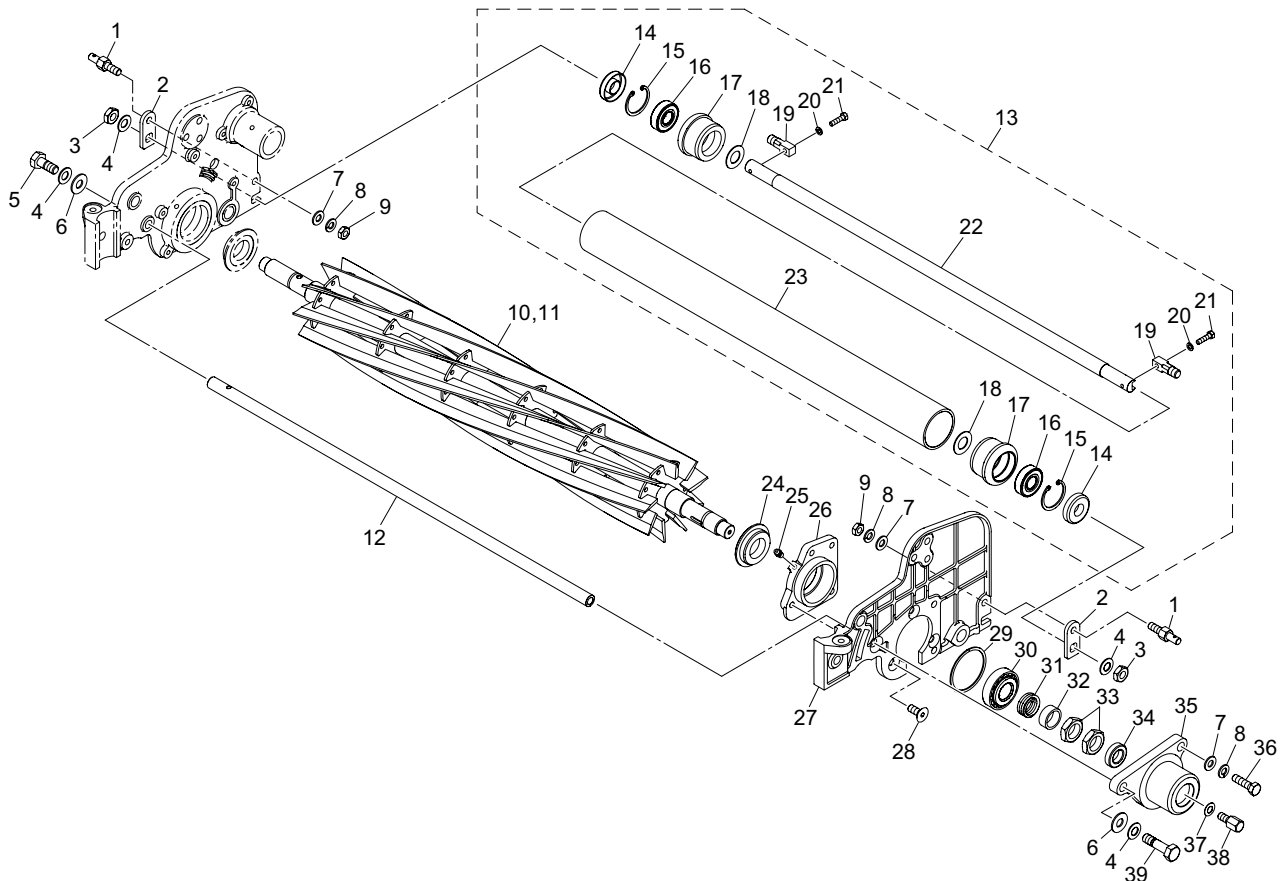

LM101_01_z00

| Cat No. | Code No. | Part name | Qty | Remark | SN of application |
|---------|---------------|----------------------------------|-----|--------|-------------------|
| 1 - 29 | K0880050000 | O-RING, P50 | 1 | | |
| 1 - 30 | K0631302040 | BEARING, TAPER ROLLER JRP6 30204 | 1 | | |
| 1 - 31 | K1000000740 | SPRING, COMPRESSION M3.2-26.9-22 | 1 | | |
| 1 - 32 | K6212000630 | COLLAR, STKM M20.2-25.4-10 | 1 | | |
| 1 - 33 | K0160000082 | NUT, SPECIAL P1.5 M20-8 | 2 | | |
| 1 - 34 | K0821628070 | OIL SEAL, MHSA16287 | 1 | | |
| 1 - 35 | LM54G--0111ZR | COVER, REEL SHAFT | 1 | | |
| 1 - 36 | K0000080302 | BOLT, M8-30 | 2 | | |
| 1 - 37 | K0210080002 | SPRING, CONICAL DISC L M8 | 1 | | |
| 1 - 38 | LM101--0112Z2 | BOLT, RAPPING | 1 | | |
| 1 - 39 | K0071000592 | BOLT, POSITIONING M10-40 | 1 | | |
| | | | | | |
| | | | | | |
| | | | | | |
| | | | | | |

2. Cutting section B

LM101

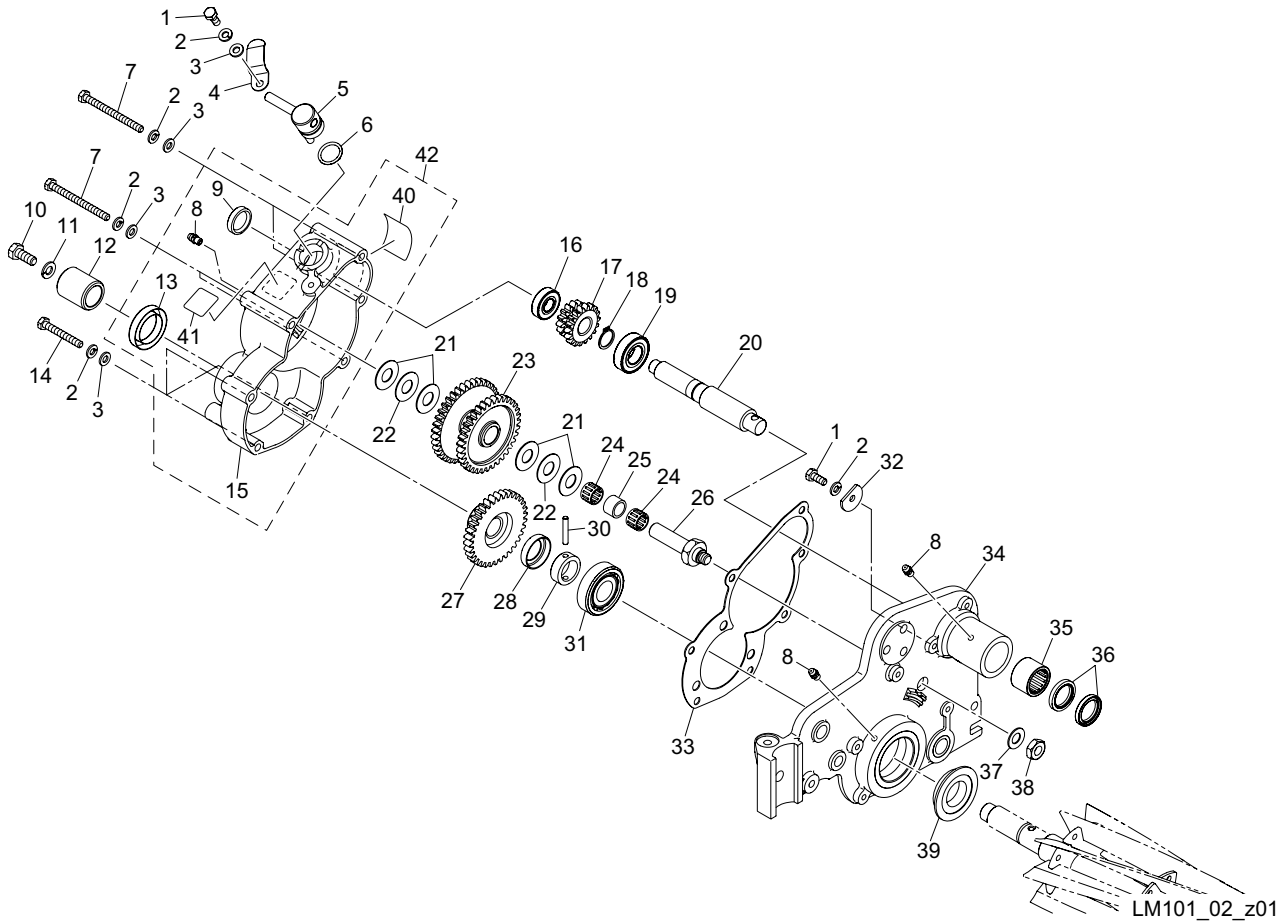

| Cat No. | Code No. | Part name | Qty | Remark | SN of application |
|---------|---------------|---------------------------------|-----|--------|-------------------|
| 2 - 1 | K0000060152 | BOLT, M6-15 | 2 | | |
| 2 - 2 | K0200060002 | WASHER, SPRING M6 | 9 | | |
| 2 - 3 | K5000060002 | WASHER, M6 | 8 | | |
| 2 - 4 | K1090000058 | SPRING, CLUTCH RETAINER | 1 | | |
| 2 - 5 | LM101--0107Z8 | LEVER, CLUTCH | 1 | | |
| 2 - 6 | K0880018000 | O-RING, P18 | 1 | | |
| 2 - 7 | K0000060702 | BOLT, M6-70 | 4 | | |
| 2 - 8 | K1440000010 | GREASE NIPPLE, STRAIGHT TYPE A | 3 | | |
| 2 - 9 | K0890000030 | CAP, RUBBER 25 | 1 | | |
| 2 - 10 | K0074080202 | BOLT, LEFT-HANDED M8-20 | 1 | | |
| 2 - 11 | K0200080002 | WASHER, SPRING M8 | 1 | | |
| 2 - 12 | LM101--0110Z8 | COLLAR, SECURING GEAR | 1 | | |
| 2 - 13 | K0822840080 | OIL SEAL, MHSA28408 | 1 | | |
| 2 - 14 | K0000060452 | BOLT, M6-45 | 3 | | |
| 2 - 15 | LM101--0101Z0 | COVER, GEAR (RH) | 1 | | |
| 2 - 16 | K0612060010 | BEARING, BALL SEAL 2RD 6001 | 1 | | |
| 2 - 17 | LM101--0106Z0 | GEAR, 15-TEETH /18 TEETH | 1 | | |
| 2 - 18 | K0401017001 | RING, RETAINING S M17 | 1 | | |
| 2 - 19 | K0613060030 | BEARING, BALL SEAL 2RDC3 6003 | 1 | | |
| 2 - 20 | LM101--0108Z8 | SHAFT, INLET | 1 | | |
| 2 - 21 | K5051013280 | WASHER, C5191P 1-13-28 | 4 | | |
| 2 - 22 | K5020813280 | WASHER, NBS55 0.8-13-28 | 2 | | |
| 2 - 23 | LM101--0105A0 | GEAR, 35T 38T | 1 | | |
| 2 - 24 | K0701317120 | BEARING, NEEDLE KT131712 | 2 | | |
| 2 - 25 | LM101--0113Z0 | COLLAR, GEAR | 1 | | |
| 2 - 26 | LM101--0109Z0 | COUNTERSHAFT | 1 | | |
| 2 - 27 | LM101--0104Z0 | GEAR, REEL 34 TEETH | 1 | | |
| 2 - 28 | K5300000282 | COVER, FOR PIN LOCK | 1 | | |
| 2 - 29 | K6213000040 | COLLAR, W/HOLE FOR BEARING (LH) | 1 | | |
| 2 - 30 | K6051045280 | PIN, STRAIGHT HT 4.5-28 | 1 | | |

2. Cutting section B

LM101

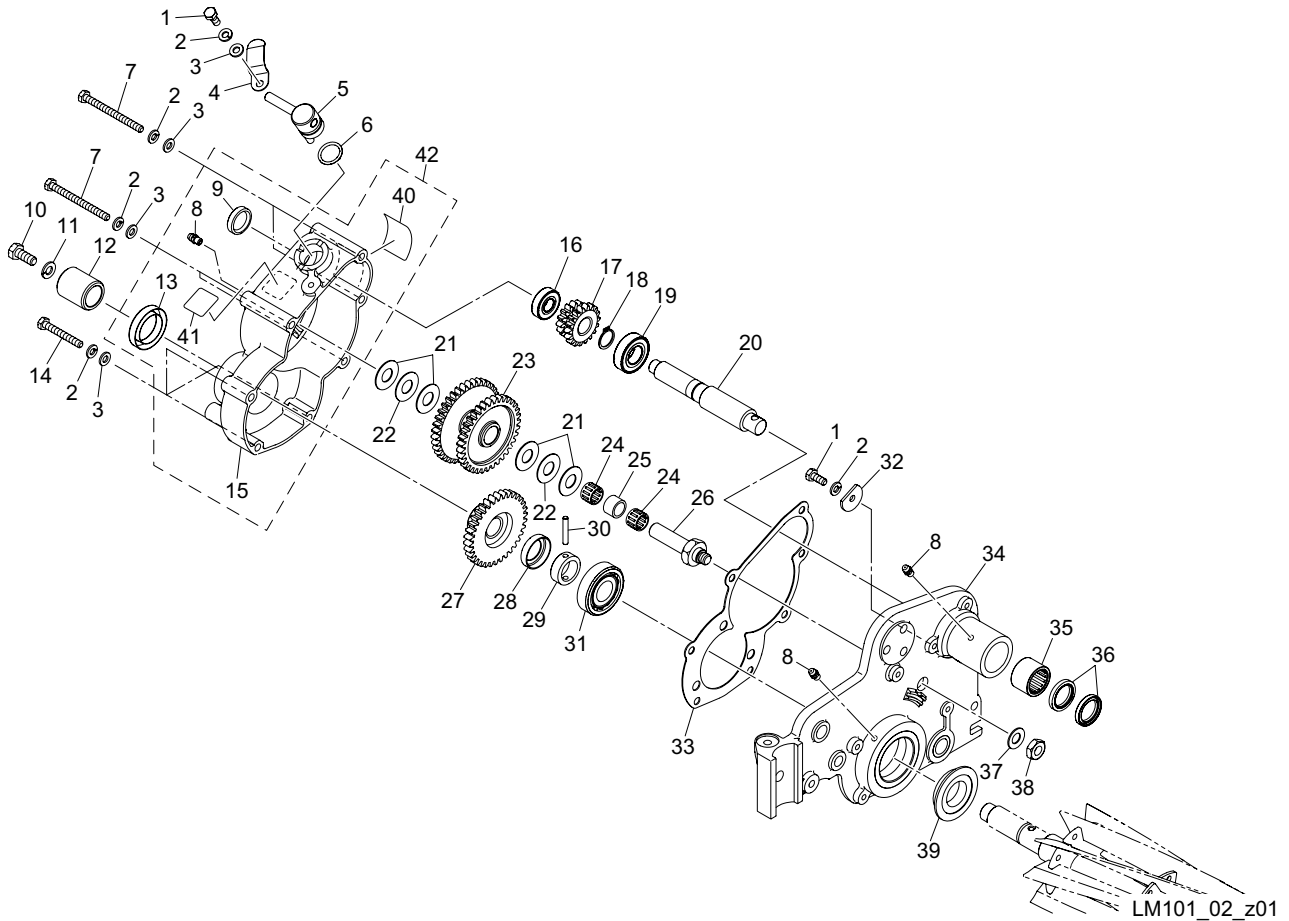

| Cat No. | Code No. | Part name | Qty | Remark | SN of application |
|---------|---------------|-----------------------------------|-----|--------|-------------------|
| 2 - 31 | K0631302040 | BEARING, TAPER ROLLER JRP6 30204 | 1 | | |
| 2 - 32 | K5090000603 | WASHER, SPCC 2.3-6-25 | 1 | | |
| 2 - 33 | LM54G--0127Z0 | PACKING, CASE | 1 | | |
| 2 - 34 | LM101--0102A0 | FRAME, (RH) | 1 | | |
| 2 - 35 | K0736000010 | BEARING, NEEDLE CAGE TAF 212920OG | 1 | | |
| 2 - 36 | K0871212940 | OIL SEAL, DS 21294 | 2 | | |
| 2 - 37 | K0210100002 | SPRING, CONICAL DISC L M10 | 1 | | |
| 2 - 38 | K0160000282 | NUT, P1 OH1 M10-3 | 1 | | |
| 2 - 39 | K0830000020 | OIL SEAL, 254210 | 1 | | |
| 2 - 40 | K4209000370 | DECAL, GREASING EACH 10-HOURS | 1 | | |
| 2 - 41 | K4203001690 | DECAL, REEL ROTATION | 1 | | |
| 2 - 42 | LM101--0154Z0 | COVER, GEAR W/DECAL (RH) | 1 | | |
| | | | | | |
| | | | | | |
| | | | | | |
| | | | | | |

3. Cutting section C

LM101

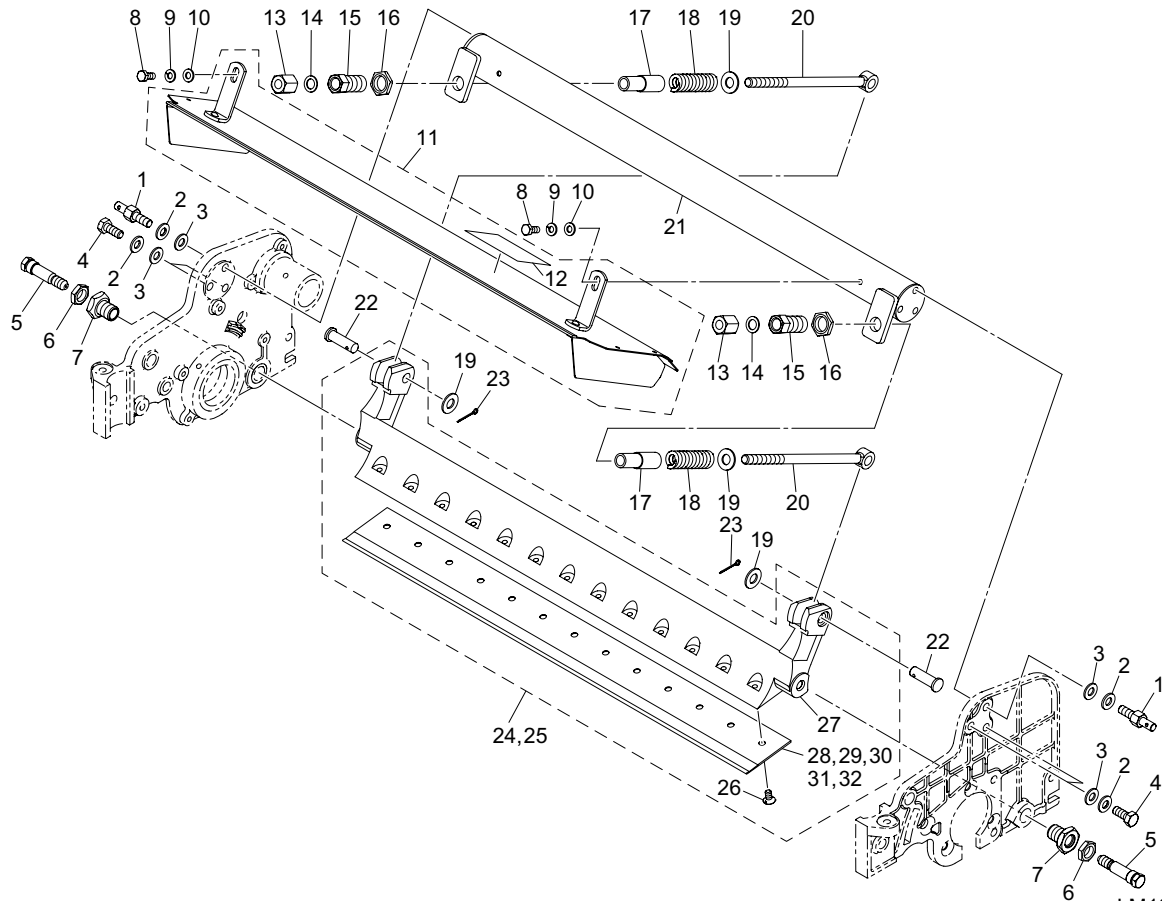

LM101_03_z00

| Cat No. | Code No. | Part name | Qty | Remark | SN of application |
|---------|---------------|-------------------------------------|-----|--------|-------------------|
| 3 - 1 | LM54GA-0149Z3 | BOLT, 45 | 2 | | |
| 3 - 2 | K0213080002 | WASHER, DISK SPRING 1H M8 | 6 | | |
| 3 - 3 | K5000080002 | WASHER, M8 | 6 | | |
| 3 - 4 | K0000080202 | BOLT, M8-20 | 4 | | |
| 3 - 5 | K6082000010 | BOLT, SUS STEPPED FOR FIXING CUTTER | 2 | | |
| 3 - 6 | K0160000112 | NUT, LOCKING | 2 | | |
| 3 - 7 | K6010000010 | BUSH, STEPPED | 2 | | |
| 3 - 8 | K0000060152 | BOLT, M6-15 | 2 | | |
| 3 - 9 | K0200060002 | WASHER, SPRING M6 | 2 | | |
| 3 - 10 | K5000060002 | WASHER, M6 | 2 | | |
| 3 - 11 | LM54GB-2001Z0 | COVER, REEL W/ DECAL | 1 | | |
| 3 - 12 | K4205001600 | DECAL, CAUTION CUTTING HANDS/FEET | 1 | | |
| 3 - 13 | K0160000032 | NUT, ADJUSTING BED-KNIFE P1 M10 | 2 | | |
| 3 - 14 | K5011010162 | WASHER, SPCC 1-10-16 | 2 | | |
| 3 - 15 | K6081000032 | PIPE, ADJUSTING CUTTER W/SCREW | 2 | | |
| 3 - 16 | K0160000122 | NUT, LOCKING ADJUSTING CUTTER | 2 | | |
| 3 - 17 | LM54GA-0117Z3 | COLLAR, 53.5 | 2 | | |
| 3 - 18 | K1000000078 | SPRING, COMPRESSION M3.5-17.5-60 | 2 | | |
| 3 - 19 | K5000100002 | WASHER, M10 | 4 | | |
| 3 - 20 | K6511000052 | BOLT, ADJUSTING CUTTER 185 | 2 | | |
| 3 - 21 | LM54GA-0113ZR | STAY, MOWER | 1 | | |
| 3 - 22 | K6032000052 | PIN, FLAT HEAD M10-32 | 2 | | |
| 3 - 23 | K0300025202 | PIN, COTTER M2.5-20 | 2 | | |
| 3 - 24 | LM101--0152Z0 | BEDKNIFE COMP, 1.5 | 1 | | 10470-10833 |
| 3a-24 | LM101--0152A0 | BEDKNIFE COMP, 1.5 | 1 | | 10834- |
| 3 - 25 | LM101--1952Z0 | BEDKNIFE COMP, 2.0 | 1 | | 10470-10833 |
| 3a-25 | LM101--1952A0 | BEDKNIFE COMP, 2.0 | 1 | | 10834- |
| 3 - 26 | K0071000222 | SCREW, HT + FLAT HEAD M6-12 | 13 | | |
| 3 - 27 | LM54GA-0120AR | BASE, BEDKNIFE | 1 | | 10470-10833 |
| 3a-27 | LM54GA-0120BR | BASE, BEDKNIFE | 1 | | 10834- |

3. Cutting section C

LM101

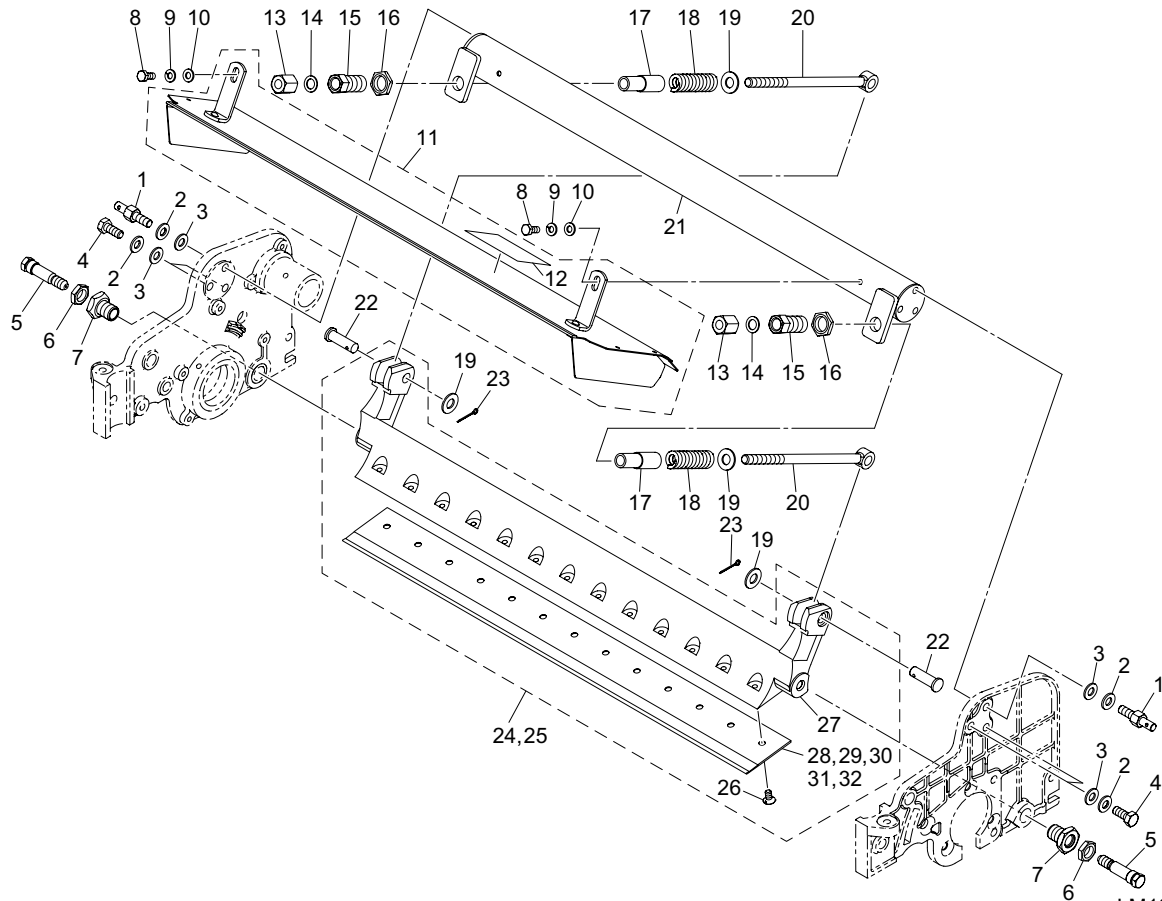

LM101_03_z00

| Cat No. | Code No. | Part name | Qty | Remark | SN of application |
|---------|-------------|-------------------------------|-----|--------|-------------------|
| 3 - 28 | K2511000270 | BEDKNIFE, 1.5-22 | 1 | | |
| 3 - 29 | K2511000280 | BEDKNIFE, 2.0-22 | 1 | | |
| 3 - 30 | K2511000050 | BEDKNIFE, 2.5-22 | 1 | | |
| 3 - 31 | K2510000060 | BEDKNIFE, TIPPED 3.0-62.5-559 | 1 | | |
| 3 - 32 | K2510000160 | BEDKNIFE, TIPPED 5.0-62.5-559 | 1 | | |
| | | | | | |
| | | | | | |
| | | | | | |
| | | | | | |
| | | | | | |
| | | | | | |
| | | | | | |
| | | | | | |

4. Cutting section D (Grooved roller)

LM101

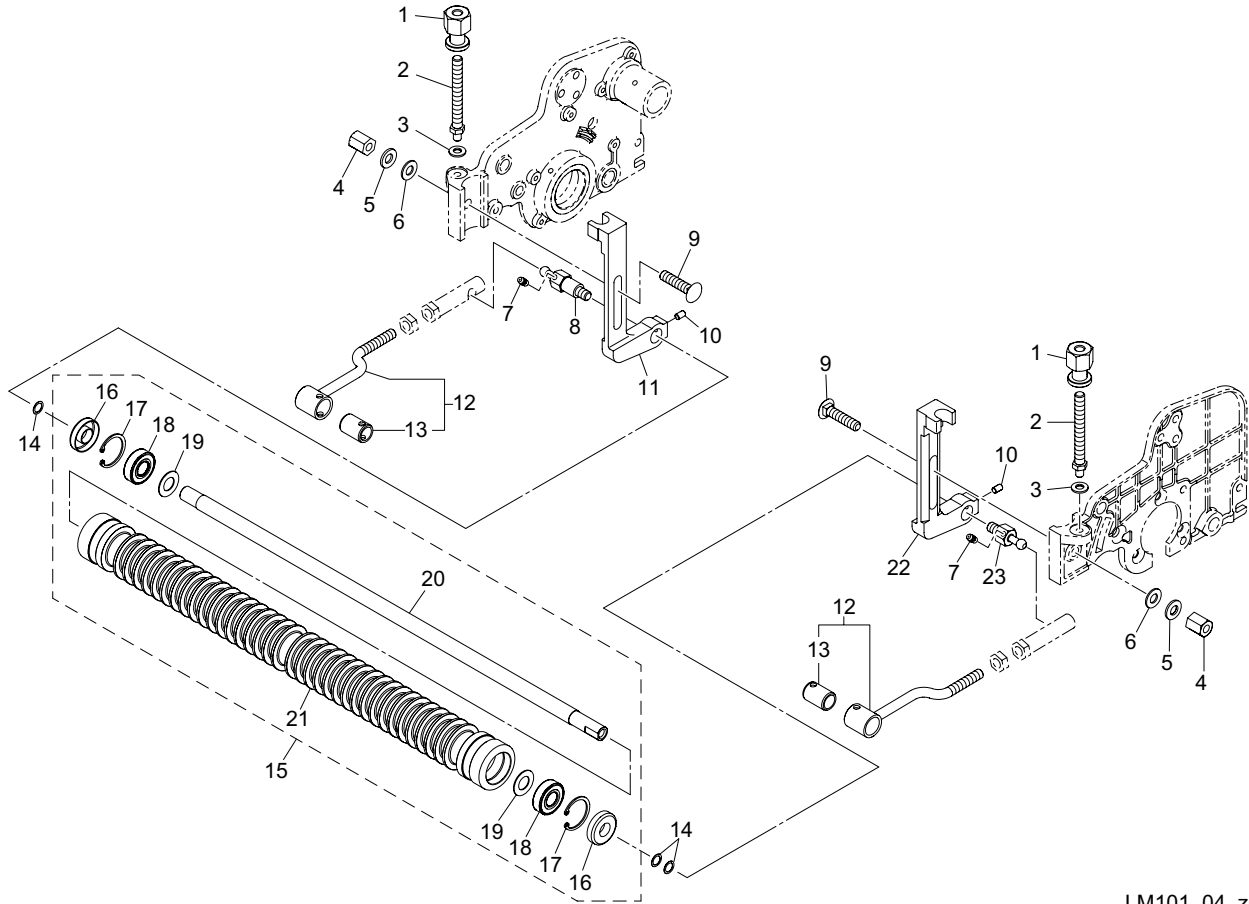

LM101_04_z00

| Cat No. | Code No. | Part name | Qty | Remark | SN of application |
|---------|---------------|--------------------------------|-----|----------------|-------------------|
| 4 - 1 | K6084000162 | ADJUSTER FOR ROLLER (IGCA) | 2 | | |
| 4 - 2 | LM101--0121Z0 | BOLT, SUS ADJ HOC | 2 | | |
| 4 - 3 | K0213080002 | WASHER, DISK SPRING 1H M8 | 2 | | |
| 4 - 4 | K0149107202 | NUT, HIGH M10-17-20 | 2 | | |
| 4 - 5 | K0213100002 | WASHER, DISK SPRING 1H M10 | 2 | | |
| 4 - 6 | K5000100002 | WASHER, M10 | 2 | | |
| 4 - 7 | K1440000010 | GREASE NIPPLE, STRAIGHT TYPE A | 2 | | |
| 4 - 8 | LM54G--0133Z0 | BOLT, SUS MOUNTING MOWER (RH) | 1 | | |
| 4 - 9 | K0025100452 | BOLT,CARRIAGE M10-45 | 2 | | |
| 4 - 10 | K0028060100 | SETSCREW, SUS M6-10 | 2 | | |
| 4 - 11 | LM101--0116Z2 | BRACKET, ROLLER (RH) | 1 | | |
| 4 - 12 | LM54G--0823Z0 | FITTING, MOWER LM54GB | 2 | | |
| 4 - 13 | K6000000150 | BUSH, W/HOLE 15-20-29 | 2 | | |
| 4 - 14 | K5050310140 | WASHER, C5191P 0.3-10-14 | 0~6 | for adjustment | |
| 4 - 15 | LM101--0151Z0 | ROLLER ASSY, GROOVED | 1 | | |
| 4 - 16 | K0851535080 | OIL SEAL, PJN15358 | 2 | | |
| 4 - 17 | K0402035001 | RING, RETAINING R M35 | 2 | | |
| 4 - 18 | K0612062020 | BEARING, BALL SEAL 2RD 6202 | 2 | | |
| 4 - 19 | K5051015280 | WASHER, C5191P 1-15-28 | 2 | | |
| 4 - 20 | LM101--0118Z2 | SHAFT, ROLLER | 1 | | |
| 4 - 21 | LM101--0117Z3 | ROLLER, GROOVED | 1 | | |
| 4 - 22 | LM101--0115Z2 | BRACKET, ROLLER (LH) | 1 | | |
| 4 - 23 | LM54G--0132Z0 | BOLT, SUS MOUNTING MOWER (LH) | 1 | | |

5. Wheel section A (Tire)

LM101

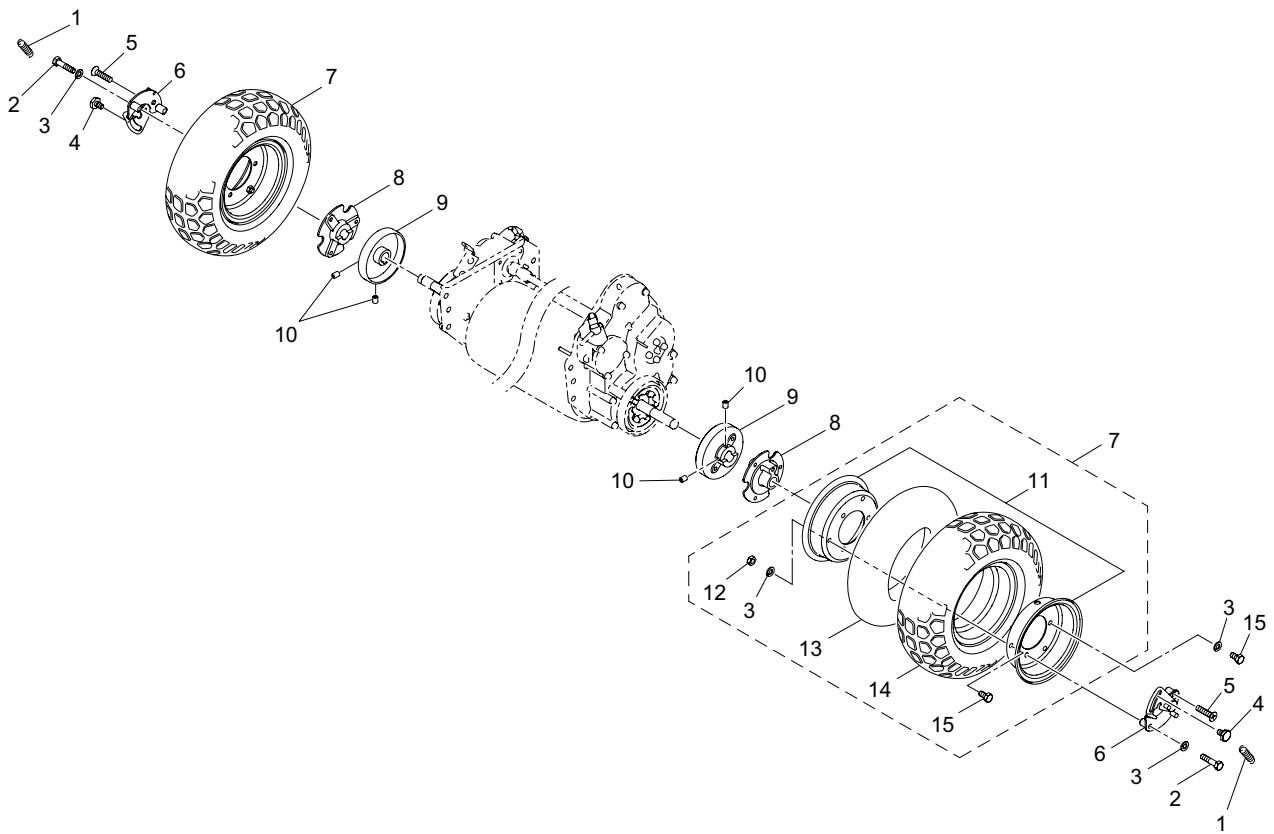

LM101_05_z00

| Cat No. | Code No. | Part name | Qty | Remark | SN of application |
|---------|---------------|--------------------------------|-----|--------|-------------------|
| 5 - 1 | K1030000068 | SPRING, W/U HOOK M1.5-8.5-35.5 | 2 | | |
| 5 - 2 | K0000080352 | BOLT, M8-35 | 2 | | |
| 5 - 3 | K0200080002 | WASHER, SPRING M8 | 10 | | |
| 5 - 4 | K6082000023 | BOLT, STEPPED M8-10 | 2 | | |
| 5 - 5 | K0041080352 | SCREW, + FLAT HEAD M8-35 | 2 | | |
| 5 - 6 | LM55GB-0242C2 | PLATE, CLAMPING WHEEL | 2 | | |
| 5 - 7 | K2020000050 | TIRE ASSY, 4.10/3.50-6 | 2 | | |
| 5 - 8 | LM55GD-0239AD | MOUNT, WHEEL | 2 | | 10470-10716 |
| 5a- 8 | LM55GD-0239CD | MOUNT, WHEEL | 2 | | 10717- |
| 5 - 9 | LM55GD-0238Z2 | DRUM, BRAKE | 2 | | |
| 5 - 10 | K0023080101 | SETSCREW, M8-10 | 4 | | |
| 5 - 11 | K2080000040 | WHEEL COMP, 3SP-6 | 2 | | |
| 5 - 12 | K0100080003 | NUT, M8 | 6 | | |
| 5 - 13 | K2091000220 | TUBE, TIRE 4.10/3.50-6 | 2 | | |
| 5 - 14 | K2021000030 | TIRE, 4.10/3.50-6 | 2 | | |
| 5 - 15 | K0000080152 | BOLT, M8-15 | 8 | | |
| | | | | | |
| | | | | | |

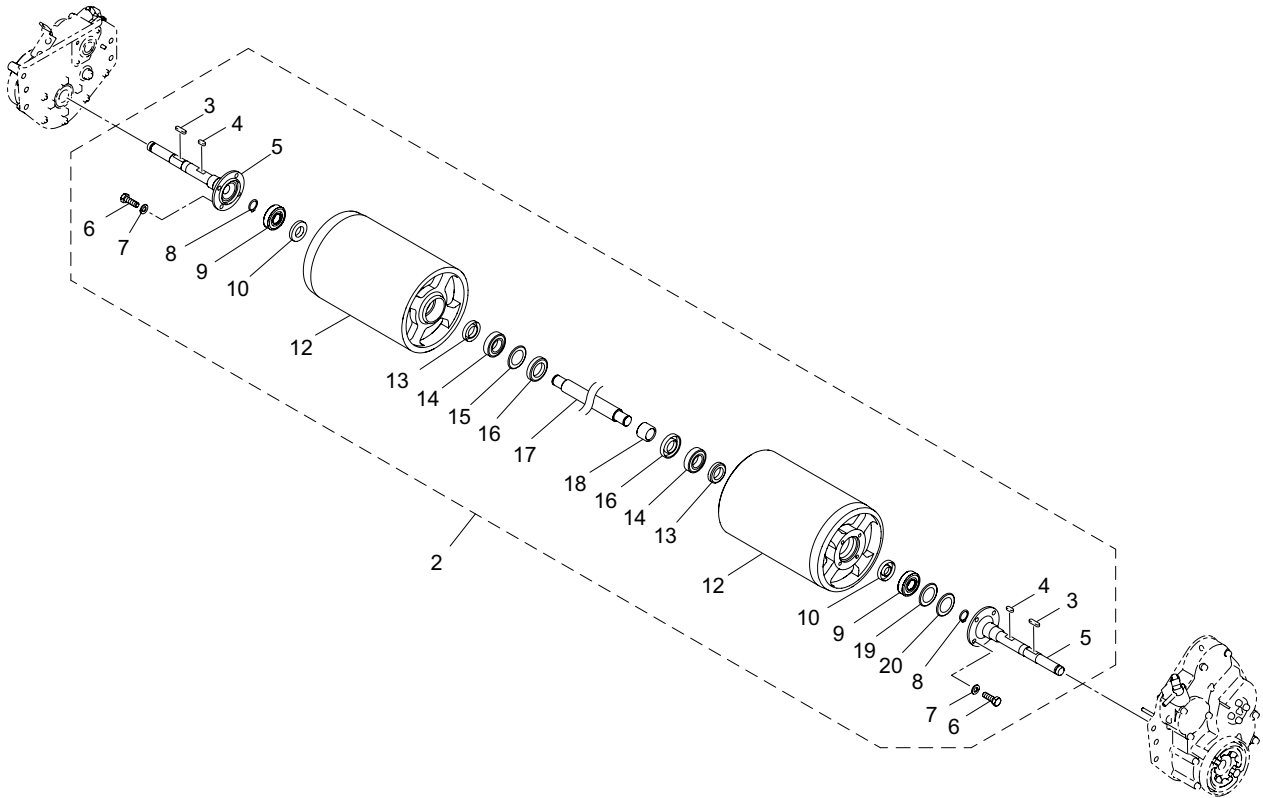

LM101_06_a00

| Cat No. | Code No. | Part name | Qty | Remark | SN of application |
|---------|---------------|-------------------------------|-----|----------------|-------------------|
| 6a- 1 | | | | | |
| 6 - 2 | LM101--2801Z0 | DRUM & SHAFT ASSY, ND | 1 | | |
| 6 - 3 | K0500505280 | KEY, BOTH ROUND M5-528 | 2 | | |
| 6 - 4 | K0500505160 | KEY, BOTH ROUND M5-516 | 2 | | |
| 6 - 5 | LM101--0204Z2 | SHAFT, DRUM (OUTER) | 2 | | |
| 6 - 6 | K0000080252 | BOLT, M8-25 | 8 | | |
| 6 - 7 | K0200080002 | WASHER, SPRING M8 | 8 | | |
| 6 - 8 | K0401020001 | RING, RETAINING S M20 | 2 | | |
| 6 - 9 | K0613062040 | BEARING, BALL SEAL 2RDC3 6204 | 2 | | |
| 6 - 10 | K0812040070 | OIL SEAL, MHS20407 | 2 | | |
| 6a- 11 | | | | | |
| 6 - 12 | LM101--2802Z0 | DRUM, ND | 2 | | |
| 6 - 13 | K0852540080 | OIL SEAL, PJN25408 | 2 | | |
| 6 - 14 | K0608060050 | BEARING, BALL SEAL 2RS 6005 | 2 | | |
| 6 - 15 | K5010525322 | WASHER, SPCC 0.5-25-32 | 1 | for adjustment | |
| 6 - 16 | K0823047080 | OIL SEAL, MHSA30478 | 2 | | |
| 6 - 17 | LM101--0203Z2 | SHAFT, DRUM (INNER) | 1 | | |
| 6 - 18 | K6212002592 | COLLAR, STKM 25.1-30-21.5 | 1 | | |
| 6 - 19 | K5010320282 | WASHER, SPCC 0.3-20-28 | 1 | for adjustment | |
| 6 - 20 | K5011020282 | WASHER, SPCC 1-20-28 | 1 | for adjustment | |
| | | | | | |
| | | | | | |

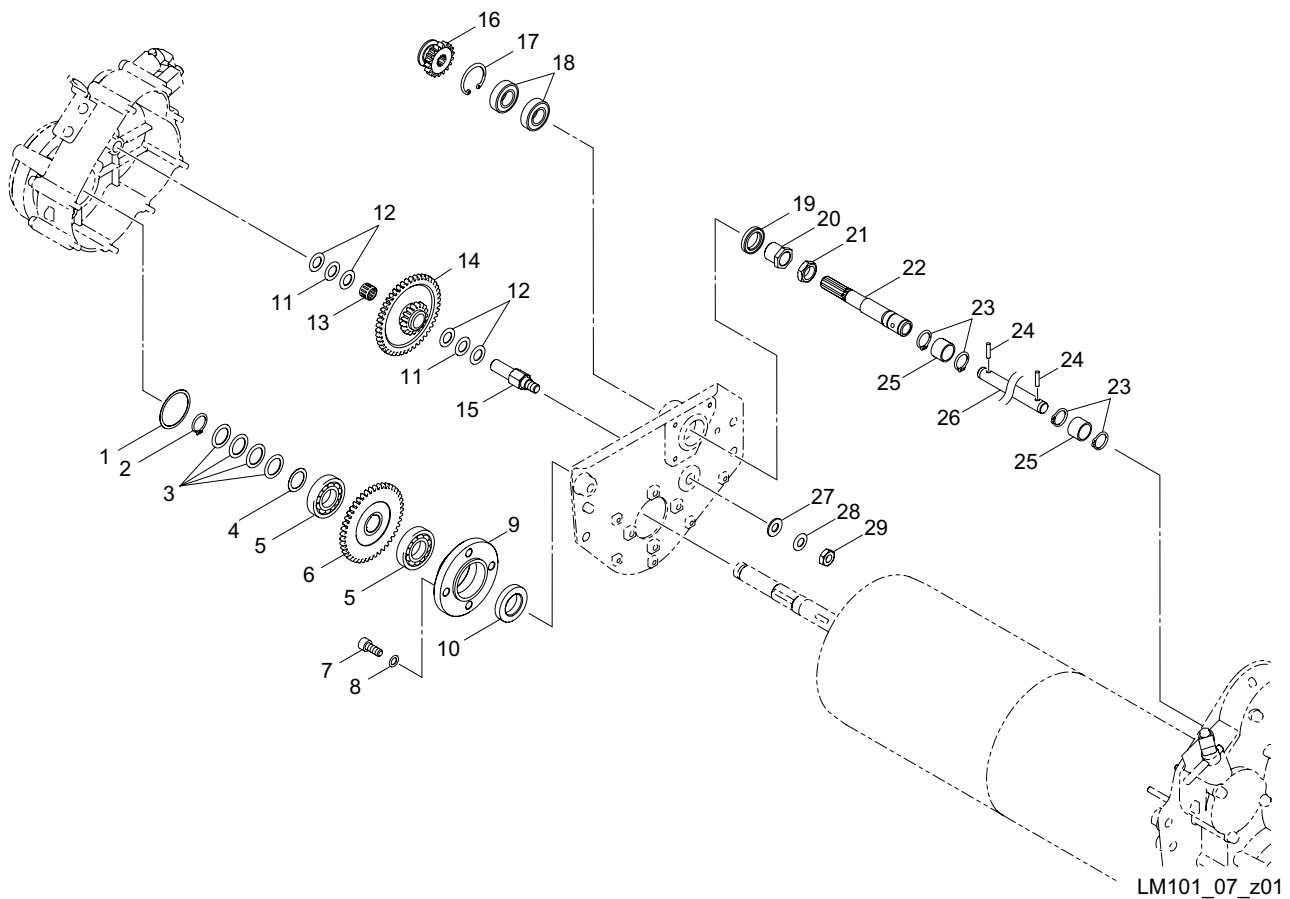

LM101_07_z01

| Cat No. | Code No. | Part name | Qty | Remark | SN of application |
|---------|---------------|--------------------------------|-----|----------------|-------------------|
| 7 - 1 | K5010340462 | WASHER, SPCC 0.3-40-46.5 | 1~3 | for adjustment | |
| 7 - 2 | K0401020001 | RING, RETAINING S M20 | 1 | | |
| 7 - 3 | K5011020282 | WASHER, SPCC 1-20-28 | 4 | | |
| 7 - 4 | K5010320282 | WASHER, SPCC 0.3-20-28 | 1 | for adjustment | |
| 7 - 5 | K0601062040 | BEARING, BALL C3 6204 | 2 | | |
| 7 - 6 | LM54GA-0221B0 | GEAR, 45T FOR WHEEL SHAFT (RH) | 1 | | |
| 7 - 7 | K001A080201 | BOLT, 13T W/HEX HOLE M8-20 | 4 | | |
| 7 - 8 | K0215080002 | WASHER, DISK SPRING 2H M8 | 4 | | |
| 7 - 9 | LM54G--0229Z0 | HOUSING, AXLE (RH) | 1 | | |
| 7 - 10 | K0822542080 | OIL SEAL, MHSA25428 | 1 | | |
| 7 - 11 | K5020813220 | WASHER, NBS55 0.8-13-22 | 2 | | |
| 7 - 12 | K5051013220 | WASHER, C5191P 1-13-22 | 4 | | |
| 7 - 13 | K0711317200 | BEARING, NEEDLE KTW131720E01C3 | 1 | | |
| 7 - 14 | LM54GA-0219A0 | GEAR, DOUBLE 46-/17-TEETH (RH) | 1 | | |
| 7 - 15 | LM54G--0228Z0 | SHAFT, #2 FOR FRAME (RH) | 1 | | |
| 7 - 16 | K6180000090 | GEAR, 18-TEETH M2 SPLINE | 1 | | |
| 7 - 17 | K0402035001 | RING, RETAINING R M35 | 1 | | |
| 7 - 18 | K0616062020 | BEARING, BALL SEAL 2NSEC3 6202 | 2 | | |
| 7 - 19 | K0802030050 | OIL SEAL, MH20305 | 1 | | |
| 7 - 20 | K0160000510 | NUT, SPECIAL P1 M17-22 | 1 | | |
| 7 - 21 | K0160000332 | NUT, SPECIAL P1 M17-7 | 1 | | |
| 7 - 22 | K6100000049 | SHAFT, TRANSMISSION (RH) | 1 | | |
| 7 - 23 | K0401018001 | RING, RETAINING S M18 | 4 | | |
| 7 - 24 | K0311040170 | ROLLER, NEEDLE N4*17.8 FW6-C3 | 2 | | |
| 7 - 25 | K6211000312 | COLLAR, SGP 18.2-21.7-15 | 2 | | |
| 7 - 26 | LM54G--0225Z3 | SHAFT, TRANSMISSION | 1 | | |
| 7 - 27 | K5000100002 | WASHER, M10 | 1 | | |
| 7 - 28 | K0211100001 | SPRING, CONICAL DISC H M10 | 1 | | |
| 7 - 29 | K0160000282 | NUT, P1 OH1 M10-3 | 1 | | |

8. Wheel section D

LM101

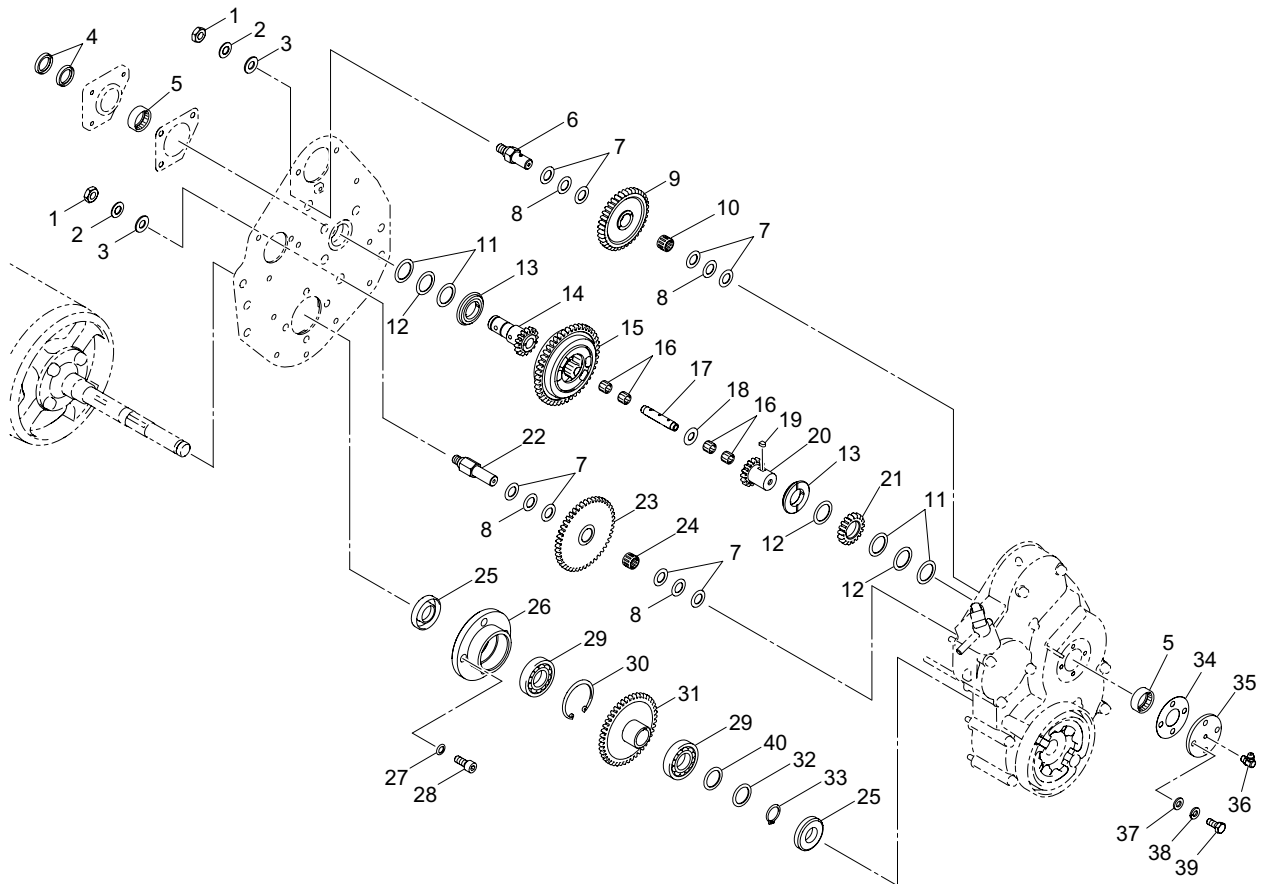

LM101_08_z01

| Cat No. | Code No. | Part name | Qty | Remark | SN of application |
|---------|---------------|--------------------------------|-----|--------|-------------------|
| 8 - 1 | K0160000282 | NUT, P1 OH1 M10-3 | 2 | | |
| 8 - 2 | K0211100001 | SPRING, CONICAL DISC H M10 | 2 | | |
| 8 - 3 | K5000100002 | WASHER, M10 | 2 | | |
| 8 - 4 | K0870182640 | OIL SEAL, OS 18264 | 2 | | |
| 8 - 5 | K0722210000 | BEARING, NEEDLE TAZ 2210 | 2 | | |
| 8 - 6 | LM54G--0201Z0 | SHAFT, #2 | 1 | | |
| 8 - 7 | K5051013220 | WASHER, C5191P 1-13-22 | 8 | | |
| 8 - 8 | K5020813220 | WASHER, NBS55 0.8-13-22 | 4 | | |
| 8 - 9 | LM54G--0202Z0 | GEAR, 38-TEETH | 1 | | |
| 8 - 10 | K0701317120 | BEARING, NEEDLE KT131712 | 1 | | |
| 8 - 11 | K5051022300 | WASHER, C5191P 1-22-30 | 4 | | |
| 8 - 12 | K5020822300 | WASHER, NBS55 0.8-22-30 | 3 | | |
| 8 - 13 | K6202000140 | RETAINER, DIFF GEAR | 2 | | |
| 8 - 14 | LM55GB-0210A3 | GEAR, DIFF 16-TEETH (RH) | 1 | | |
| 8 - 15 | LM54G--0203Z0 | GEAR ASSY, DIFF 50-TEETH | 1 | | |
| 8 - 16 | K0701013100 | BEARING, NEEDLE KT101310EGB2 | 4 | | |
| 8 - 17 | K6150000150 | PIN, FOR DIFF GEAR M10-55 | 1 | | |
| 8 - 18 | K5051010220 | WASHER, C5191P 1-10-22 | 1 | | |
| 8 - 19 | K0520504060 | KEY, ROUND/SQUARE, M5-46.3 | 1 | | |
| 8 - 20 | LM55GB-0209C0 | GEAR, DIFF 16-TEETH (LH) | 1 | | |
| 8 - 21 | LM55GB-0214A0 | GEAR, 18-TEETH (LH) | 1 | | |
| 8 - 22 | LM54G--0218Z0 | SHAFT, #4 LEFT FRAME | 1 | | |
| 8 - 23 | LM54GA-0220A0 | GEAR, DOUBLE 46-/17-TEETH (LH) | 1 | | |
| 8 - 24 | K0711317200 | BEARING, NEEDLE KTW131720E01C3 | 1 | | |
| 8 - 25 | K0822542080 | OIL SEAL, MHSA25428 | 2 | | |
| 8 - 26 | LM54G--0222Z0 | HOUSING, AXLE (LH) | 1 | | |
| 8 - 27 | K0215080002 | WASHER, DISK SPRING 2H M8 | 4 | | |
| 8 - 28 | K001A080201 | BOLT, 13T W/HEX HOLE M8-20 | 4 | | |
| 8 - 29 | K0601062040 | BEARING, BALL C3 6204 | 2 | | |
| 8 - 30 | K0402047001 | RING, RETAINING R M47 | 1 | | |

8. Wheel section D

LM101

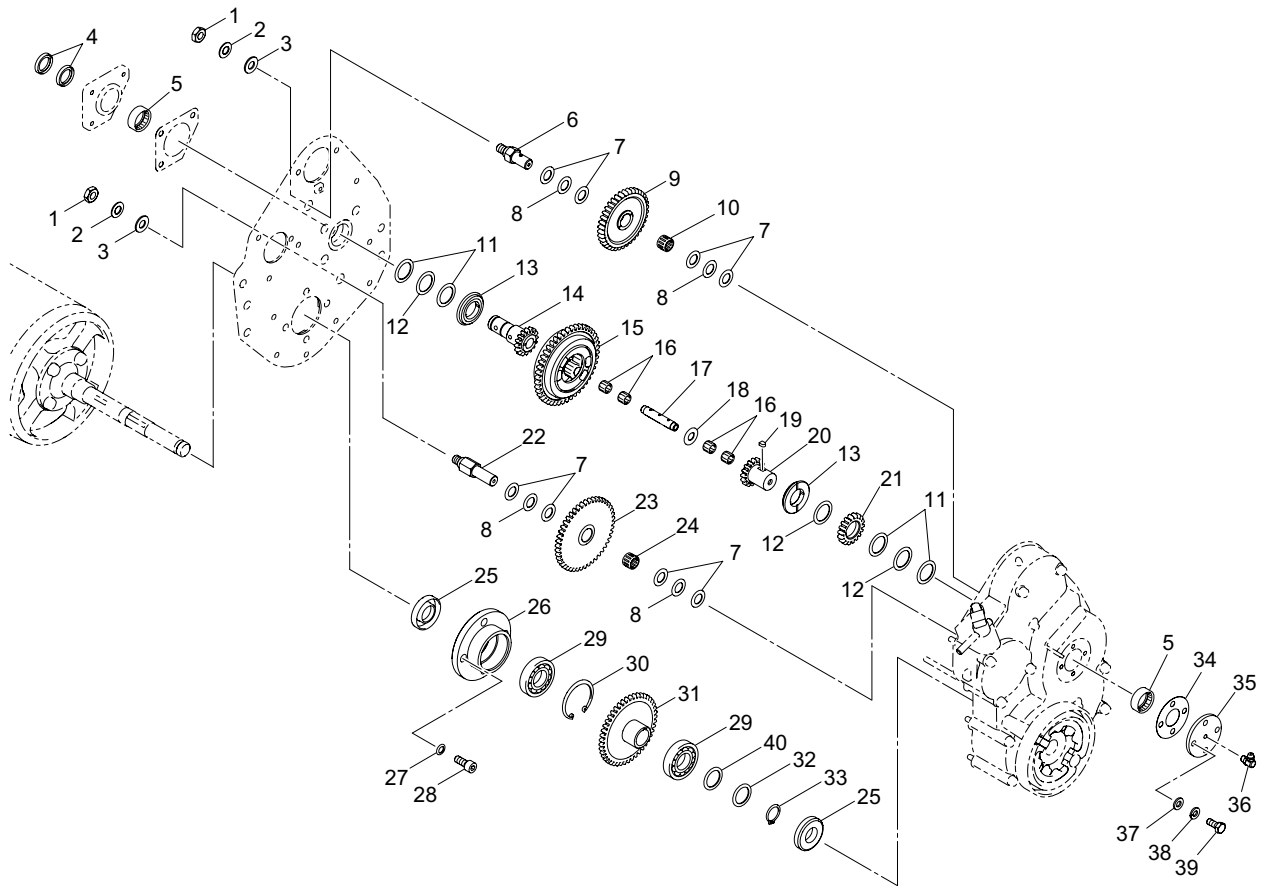

LM101_08_z01

| Cat No. | Code No. | Part name | Qty | Remark | SN of application |
|---------|---------------|--------------------------------|-----|----------------|-------------------|
| 8 - 31 | LM54GA-0223A0 | GEAR, 45T FOR WHEEL SHAFT (LH) | 1 | | |
| 8 - 32 | K5010320282 | WASHER, SPCC 0.3-20-28 | 1 | for adjustment | |
| 8 - 33 | K0401020001 | RING, RETAINING S M20 | 1 | | |
| 8 - 34 | LM55GB-0208Z0 | PACKING, #3 SHAFT | 1 | | |
| 8 - 35 | LM55GB-0217Z0 | RETAINER, BEARING | 1 | | |
| 8 - 36 | K1440000020 | GREASE NIPPLE, TYPE C | 1 | | |
| 8 - 37 | K5000060002 | WASHER, M6 | 4 | | |
| 8 - 38 | K0200060002 | WASHER, SPRING M6 | 4 | | |
| 8 - 39 | K0000060152 | BOLT, M6-15 | 4 | | |
| 8 - 40 | K5011020282 | WASHER, SPCC 1-20-28 | 1 | | |
| | | | | | |
| | | | | | |
| | | | | | |
| | | | | | |

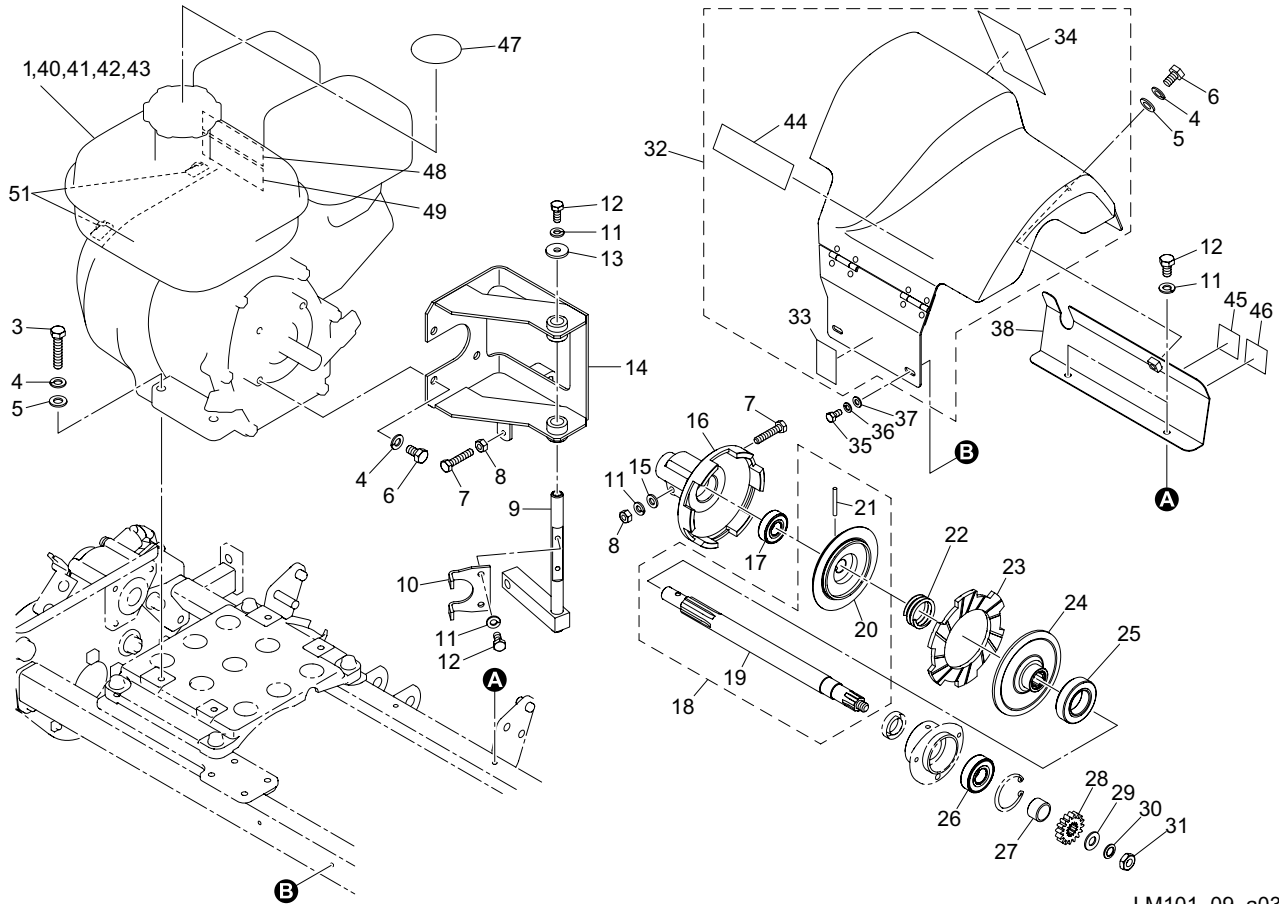

LM101_09_a03

| Cat No. | Code No. | Part name | Qty | Remark | SN of application |
|---------|---------------|--------------------------------|-----|--------|-------------------|
| 9a- 1 | K2655000030 | ENGINE, HONDA GX120UT3 | 1 | | 10470-10905 |
| 9d- 1 | K2655000040 | ENGINE, HONDA GX120UT3X | 1 | | 10906-11241 |
| 9e- 1 | K2655000050 | ENGINE, HONDA GX120T3 | 1 | | 11242- |
| 9a- 2 | | | | | |
| 9 - 3 | K0000080352 | BOLT, M8-35 | 4 | | |
| 9a- 4 | K0200080002 | WASHER, SPRING M8 | 9 | | |
| 9a- 5 | K5000080002 | WASHER, M8 | 5 | | |
| 9a- 6 | K0000080152 | BOLT, M8-15 | 5 | | |
| 9 - 7 | K0000060302 | BOLT, M6-30 | 2 | | |
| 9 - 8 | K0100060002 | NUT, M6 | 2 | | |
| 9 - 9 | LM56G--2202Z2 | LEVER, CLUTCH S | 1 | | |
| 9 - 10 | LM56G--2203Z2 | PLATE, RETAINING S | 1 | | |
| 9 - 11 | K0200060002 | WASHER, SPRING M6 | 6 | | |
| 9 - 12 | K0000060152 | BOLT, M6-15 | 5 | | |
| 9 - 13 | K5012306202 | WASHER, SPCC 2.3-6-20 | 1 | | |
| 9 - 14 | LM101--0301ZD | CASE, CLUTCH 54 | 1 | | |
| 9 - 15 | K5000060002 | WASHER, M6 | 1 | | |
| 9 - 16 | K6911000050 | CLUTCH, ENGINE | 1 | | |
| 9 - 17 | K0616062020 | BEARING, BALL SEAL 2NSEC3 6202 | 1 | | |
| 9 - 18 | LM54GB-0308Z0 | SHAFT ASSY, CLUTCH 54 | 1 | | |
| 9 - 19 | LM54GB-0307Z2 | SHAFT, ENGINE CLUTCH | 1 | | |
| 9 - 20 | K6911000043 | HOLDER, CLUTCH FADING 15 | 1 | | |
| 9 - 21 | K0310050402 | PIN, TAPERED M5-40 | 1 | | |
| 9 - 22 | K1000000160 | SPRING, COMPRESSION M3.5-34-15 | 1 | | |
| 9 - 23 | K1810000030 | LINING, CLUTCH FADING | 1 | | |
| 9 - 24 | K6911000092 | PLATE, CLUTCH | 1 | | |
| 9 - 25 | K0659000020 | BEARING, RELEASE RCT 2850 | 1 | | |
| 9 - 26 | K0616062030 | BEARING, BALL SEAL 2NSEC3 6203 | 1 | | |
| 9 - 27 | K6212001060 | COLLAR, STKM M17.1-22-14 | 1 | | |
| 9 - 28 | K6180000140 | GEAR, SPLINED 16-TEETH | 1 | | |

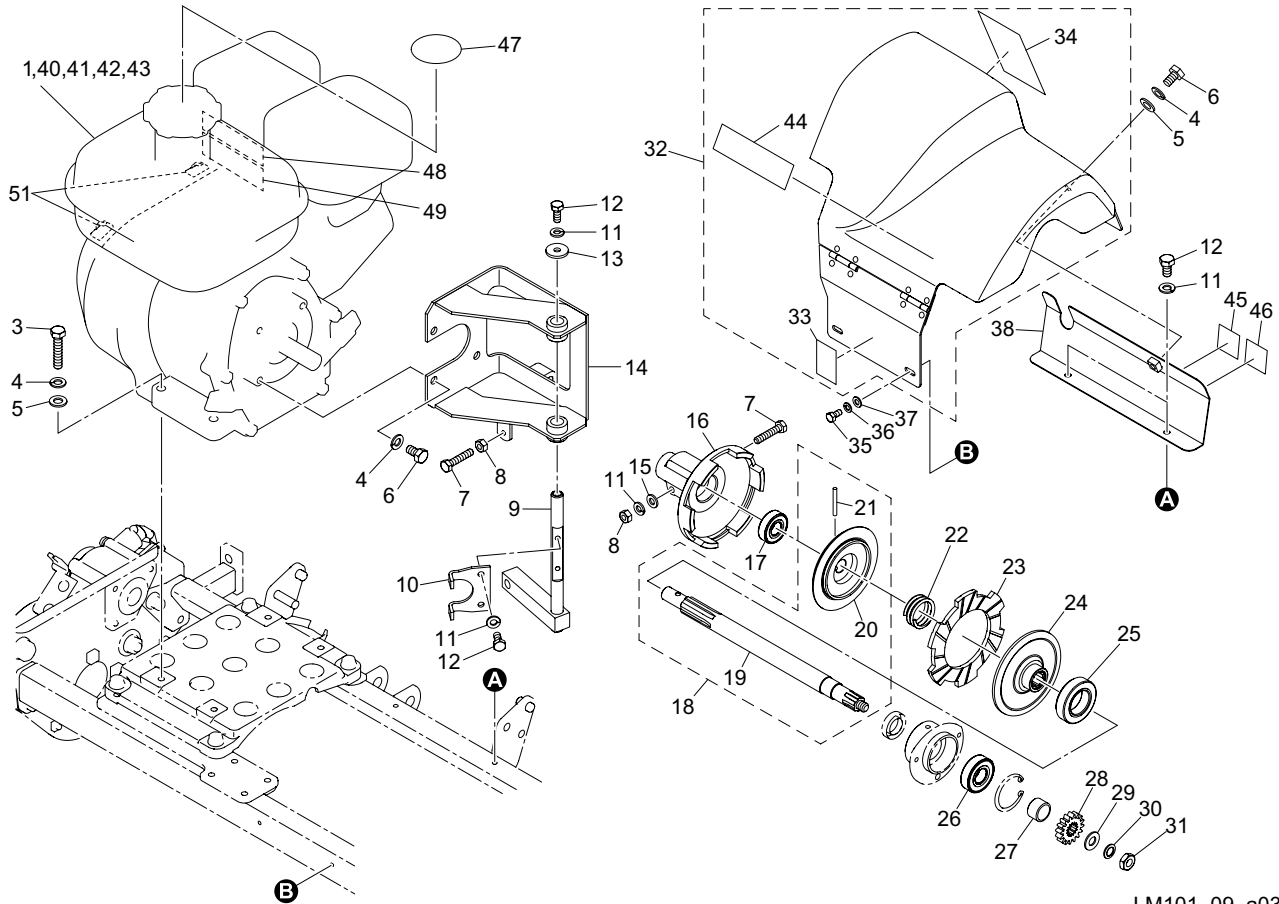

LM101_09_a03

| Cat No. | Code No. | Part name | Qty | Remark | SN of application |
|---------|------------------|--------------------------------------|-----|--------|-------------------|
| 9 - 29 | K5000100002 | WASHER, M10 | 1 | | |
| 9 - 30 | K0214100002 | WASHER, DISK SPRING 2L M10 | 1 | | |
| 9 - 31 | K0160000282 | NUT, P1 OH1 M10-3 | 1 | | |
| 9 - 32 | LM101--0302A0 | COVER ASSY, CLUTCH | 1 | | 10470-10868 |
| 9a- 32 | LM101--0302B0 | COVER ASSY, CLUTCH | 1 | | 10869- |
| 9 - 33 | K4205001760 | DECAL, CAUTION PTO | 1 | | |
| 9 - 34 | K4205002150 | DECAL, CAUTION HANDLING | 1 | | |
| 9 - 35 | K0000050102 | BOLT, M5-10 | 2 | | |
| 9 - 36 | K0200050002 | WASHER, SPRING M5 | 2 | | |
| 9 - 37 | K5000050002 | WASHER, M5 | 2 | | |
| 9 - 38 | LM101--0305ZD | RECEIVER, COVER | 1 | | |
| 9a- 39 | | | | | |
| 9a- 40 | PE920702112 | PLUG, SPARK (BPR4ES) (NGK) | 1 | | |
| 9a- 41 | PBH17210-Z4M-821 | ELEMENT, AIR CLEANER (DUAL) | 1 | | |
| 9a- 42 | PBH17218-ZE0-821 | FILTER, OUTER | 1 | | |
| 9a- 43 | PBH17232-891-000 | GROMMET, AIR CLEANER | 1 | | |
| 9 - 44 | K4201000680 | DECAL, BARONESS 95 | 1 | | |
| 9a- 45 | K4205001330 | DECAL, CAUTION NOISE | 1 | | |
| 9a- 46 | K4209000880 | DECAL, NOISE LEVEL LWA 98 | 1 | | |
| 9 - 47 | K4205001300 | DECAL, WARNING ENGINE OIL | 1 | | |
| 9a- 48 | K4205002190 | DECAL, WARNING CA P65 FOR PUSH MOWER | 1 | | 10470-10905 |
| 9a- 49 | K4205002200 | DECAL, WARNING SPARK ARRESTER | 1 | | 10470-10905 |
| 9 - 50 | | | | | |
| 9a- 51 | K4251000040 | LATCH, WIRE S10 | 2 | | |

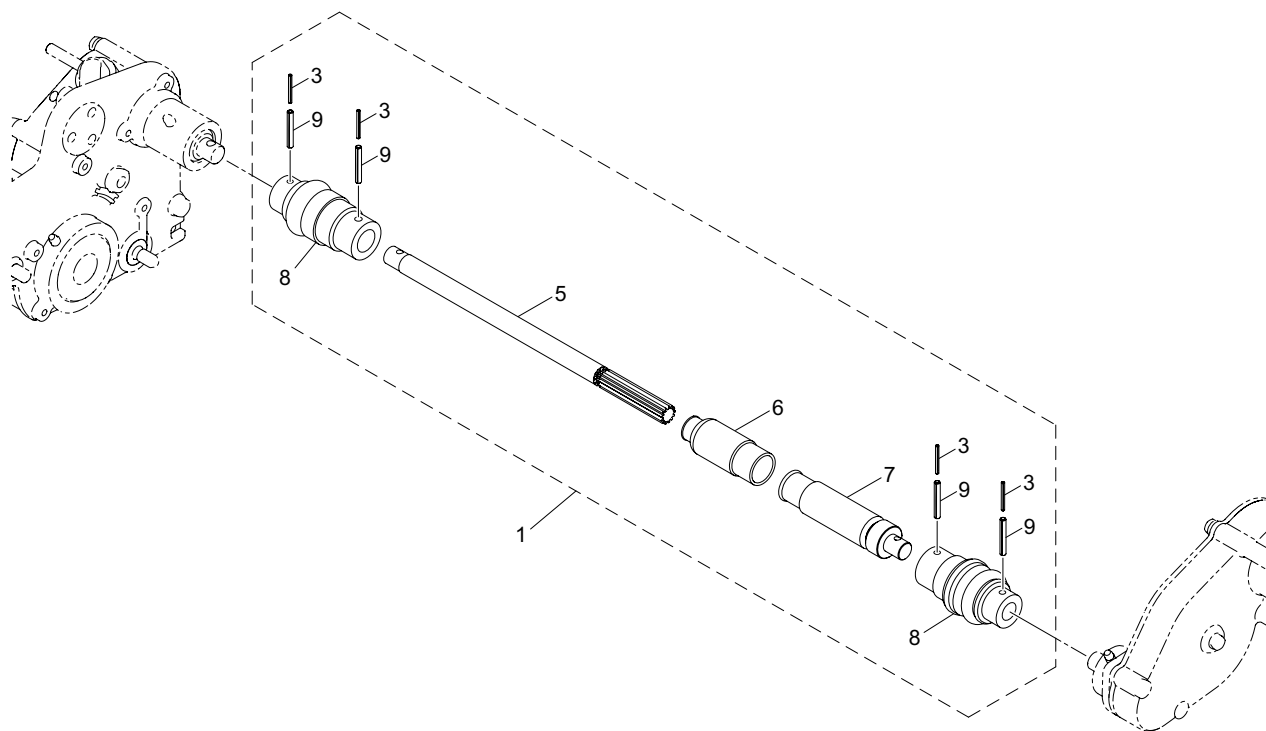

LM101_10_z02

| Cat No. | Code No. | Part name | Qty | Remark | SN of application |
|---------|---------------|------------------------|-----|--------|-------------------|
| 10 - 1 | LM101--0410B0 | JOINT ASSY | 1 | | |
| 10 - 2 | | | | | |
| 10 - 3 | K0320025251 | PIN, SPRING M2.5-25 | 4 | | |
| 10 - 4 | | | | | |
| 10 - 5 | LM54G--0402A9 | SHAFT, SPLINE | 1 | | |
| 10 - 6 | K4032000030 | RUBBER, TUBE 24-250 | 1 | | |
| 10 - 7 | LM54G--0401BD | SLEEVE, SPLINED W/BOSS | 1 | | |
| 10 - 8 | K1620000310 | JOINT, TBJ14SBC | 2 | | |
| 10 - 9 | K0320040251 | PIN, SPRING M4-25 | 4 | | |
| | | | | | |
| | | | | | |
| | | | | | |
| | | | | | |
| | | | | | |

11. Mower transmission case section

LM101

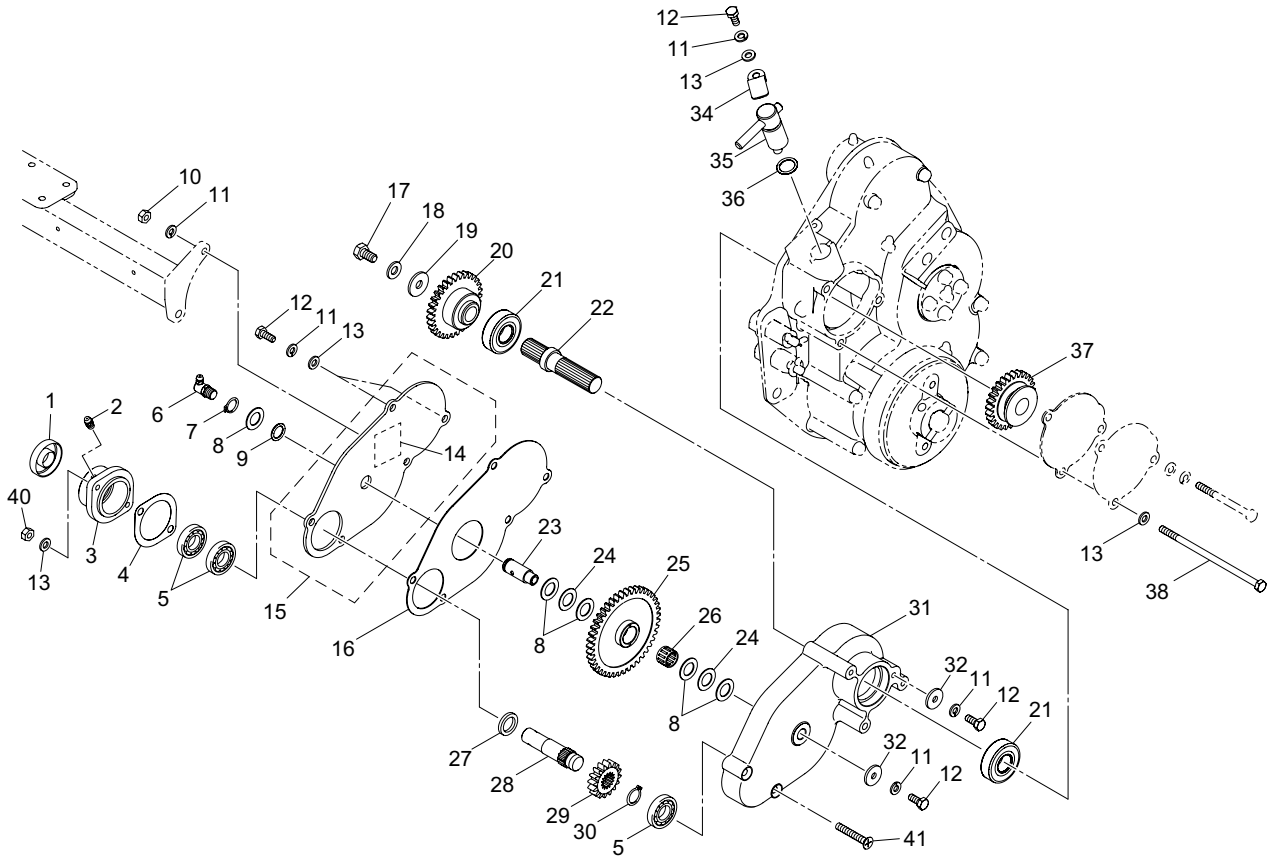

LM101_11_z03

| Cat No. | Code No. | Part name | Qty | Remark | SN of application |
|---------|---------------|--------------------------------|-----|--------|-------------------|
| 11 - 1 | K0851535080 | OIL SEAL, PJN15358 | 1 | | |
| 11 - 2 | K1440000010 | GREASE NIPPLE, STRAIGHT TYPE A | 1 | | |
| 11 - 3 | LM101--0502A2 | HOUSING | 1 | | |
| 11 - 4 | LM101--0507Z0 | PACKING, HOUSING | 1 | | |
| 11 - 5 | K0601060020 | BEARING, BALL C3 6002 | 3 | | |
| 11 - 6 | K1440000040 | GREASE NIPPLE, C TYPE PT1/8 | 1 | | |
| 11 - 7 | K0401013001 | RING, RETAINING S M13 | 1 | | |
| 11 - 8 | K5051013220 | WASHER, C5191P 1-13-22 | 5 | | |
| 11 - 9 | K0880012500 | O-RING, P12.5 | 1 | | |
| 11 - 10 | K0100060002 | NUT, M6 | 1 | | |
| 11 - 11 | K0200060002 | WASHER, SPRING M6 | 6 | | |
| 11 - 12 | K0000060152 | BOLT, M6-15 | 5 | | |
| 11 - 13 | K5000060002 | WASHER, M6 | 6 | | |
| 11 - 14 | K4209000370 | DECAL, GREASING EACH 10-HOURS | 1 | | |
| 11 - 15 | LM101--0511Z0 | PLATE, W/DECAL | 1 | | |
| 11 - 16 | LM101--0505Z0 | PACKING | 1 | | |
| 11 - 17 | K0000080152 | BOLT, M8-15 | 1 | | |
| 11 - 18 | K0213080002 | WASHER, DISK SPRING 1H M8 | 1 | | |
| 11 - 19 | K5012308242 | WASHER, SPCC 2.3-8-24 | 1 | | |
| 11 - 20 | LM54G--0504Z0 | GEAR, 31-TEETH | 1 | | |
| 11 - 21 | K0616062030 | BEARING, BALL SEAL 2NSEC3 6203 | 2 | | |
| 11 - 22 | LM54G--0503A0 | SHAFT, #1 | 1 | | |
| 11 - 23 | LM54G--0505A0 | COUNTERSHAFT | 1 | | |
| 11 - 24 | K5020813220 | WASHER, NBS55 0.8-13-22 | 2 | | |
| 11 - 25 | LM101--0506Z0 | GEAR, 43-TEETH | 1 | | |
| 11 - 26 | K0701317120 | BEARING, NEEDLE KT131712 | 1 | | |
| 11 - 27 | K6210000470 | COLLAR, 15.2-223 | 1 | | |
| 11 - 28 | LM101--0501Z8 | SHAFT, TRANSMISSION | 1 | | |
| 11 - 29 | K6180000140 | GEAR, SPLINED 16-TEETH | 1 | | |
| 11 - 30 | K0401015001 | RING, RETAINING S M15 | 1 | | |

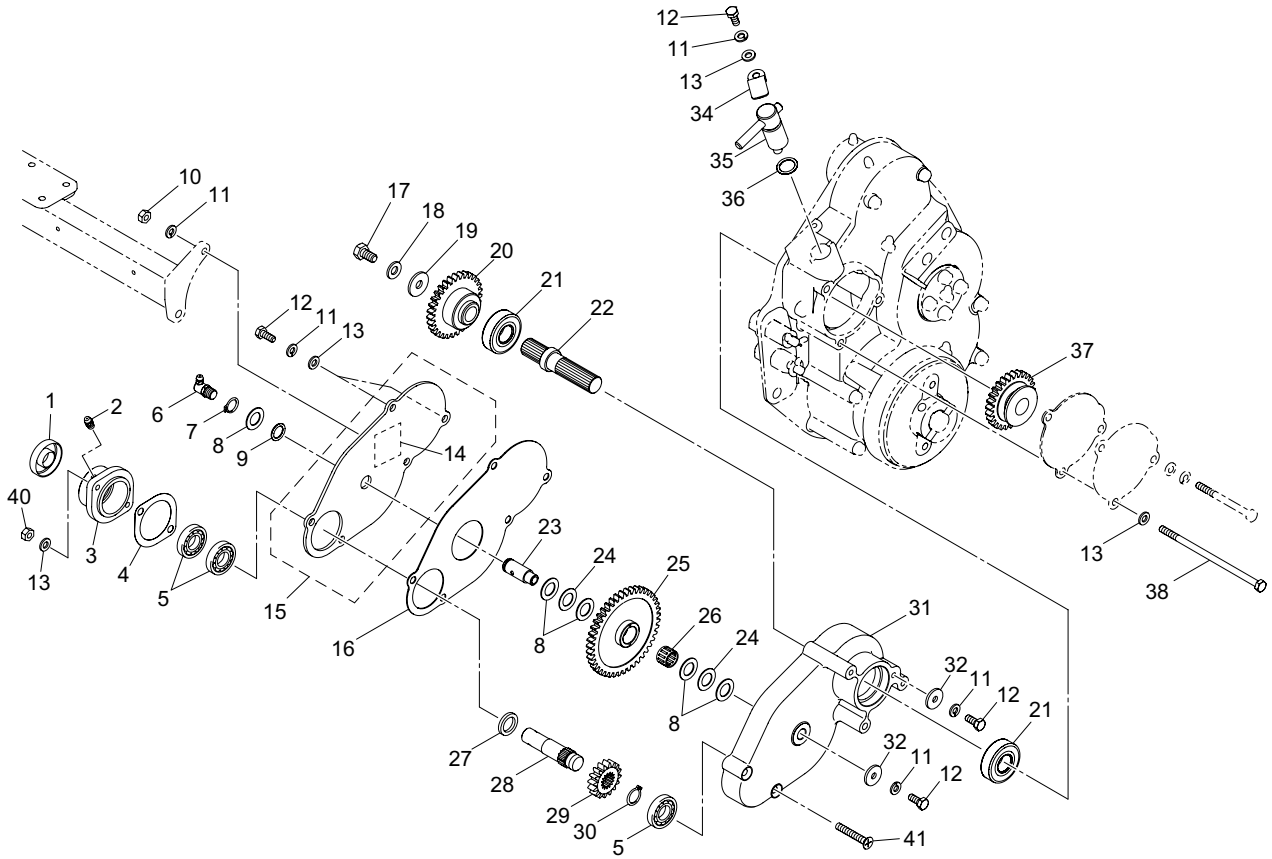

LM101_11_z03

| Cat No. | Code No. | Part name | Qty | Remark | SN of application |
|---------|---------------|--------------------------|-----|--------|-------------------|
| 11 - 31 | LM101--0503Z0 | GEARCASE | 1 | | |
| 11 - 32 | K5012306202 | WASHER, SPCC 2.3-6-20 | 2 | | |
| 11 - 33 | | | | | |
| 11 - 34 | K1090000058 | SPRING, CLUTCH RETAINER | 1 | | |
| 11 - 35 | K7321000093 | HANDLE, CLUTCH | 1 | | |
| 11 - 36 | K0880015000 | O-RING, P15 | 1 | | |
| 11 - 37 | LM54G--0512Z0 | GEAR, 27-TEETH | 1 | | |
| 11 - 38 | K0003061302 | BOLT, M6-130 | 1 | | |
| 11 - 39 | | | | | |
| 11 - 40 | K0144060002 | NUT, W/F-RING M6 | 2 | | |
| 11 - 41 | K0041060452 | SCREW, + OVAL HEAD M6-45 | 2 | | |
| | | | | | |
| | | | | | |
| | | | | | |
| | | | | | |

12. Frame section

LM101

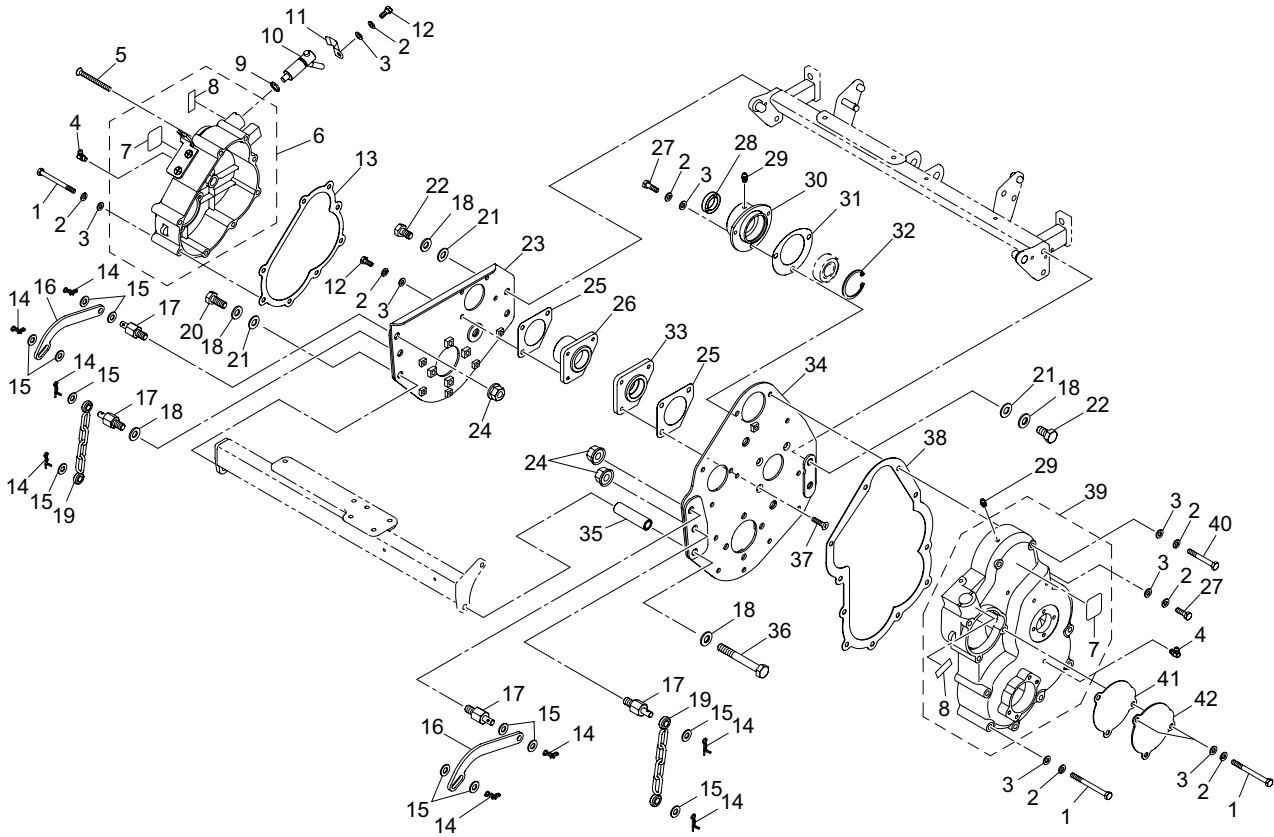

LM101_12_z01

| Cat No. | Code No. | Part name | Qty | Remark | SN of application |
|---------|---------------|--------------------------------|-----|--------|-------------------|
| 12 - 1 | K0000060702 | BOLT, M6-70 | 15 | | |
| 12 - 2 | K0200060002 | WASHER, SPRING M6 | 21 | | |
| 12 - 3 | K5000060002 | WASHER, M6 | 21 | | |
| 12 - 4 | K1440000020 | GREASE NIPPLE, 90 TYPE C | 3 | | |
| 12 - 5 | K0041060652 | SCREW, + FLAT HEAD M 6-65 | 1 | | |
| 12 - 6 | LM101--0602Z0 | COVER, FRAME W/ DECAL (RH) | 1 | | |
| 12 - 7 | K4209000370 | DECAL, GREASING EACH 10-HOURS | 2 | | |
| 12 - 8 | K4203001140 | DECAL, ON/OFF A | 2 | | |
| 12 - 9 | K0880012500 | O-RING, P12.5 | 1 | | |
| 12 - 10 | LM54G--0618Z3 | HANDLE, CLUTCH | 1 | | |
| 12 - 11 | K1090000058 | SPRING, CLUTCH RETAINER | 1 | | |
| 12 - 12 | K0000060152 | BOLT, M6-15 | 2 | | |
| 12 - 13 | LM54G--0606Z0 | PACKING, (RH) | 1 | | |
| 12 - 14 | K0340800002 | PIN, SNAP W/RETAINER M8 | 8 | | |
| 12 - 15 | K5000080002 | WASHER, M8 | 12 | | |
| 12 - 16 | LM101--0603Z3 | SUPPORT, MOWER | 2 | | |
| 12 - 17 | LM54G--0614Z3 | BOLT, HOLDING CHAIN | 4 | | |
| 12 - 18 | K0213100002 | WASHER, DISK SPRING 1H M10 | 7 | | |
| 12 - 19 | LM54G--0617Z0 | CHAIN | 2 | | |
| 12 - 20 | K0000100252 | BOLT, M10-25 | 1 | | |
| 12 - 21 | K5000100002 | WASHER, M10 | 5 | | |
| 12 - 22 | K0000100202 | BOLT, M10-20 | 4 | | |
| 12 - 23 | LM54G--0602A3 | FRAME, (RH) | 1 | | |
| 12 - 24 | K0143100002 | NUT, W/DISC S M10 | 3 | | |
| 12 - 25 | LM54G--0609Z0 | GASKET, DIFF HOUSING | 2 | | |
| 12 - 26 | LM54G--0612ZD | HOUSING, DIFF (RH) | 1 | | |
| 12 - 27 | K0000060202 | BOLT, M6-20 | 2 | | |
| 12 - 28 | K0811930070 | OIL SEAL, MHS19307 | 1 | | |
| 12 - 29 | K1440000010 | GREASE NIPPLE, STRAIGHT TYPE A | 2 | | |
| 12 - 30 | LM54GA-0608Z3 | HOUSING, #1 SHAFT | 1 | | |

12. Frame section

LM101

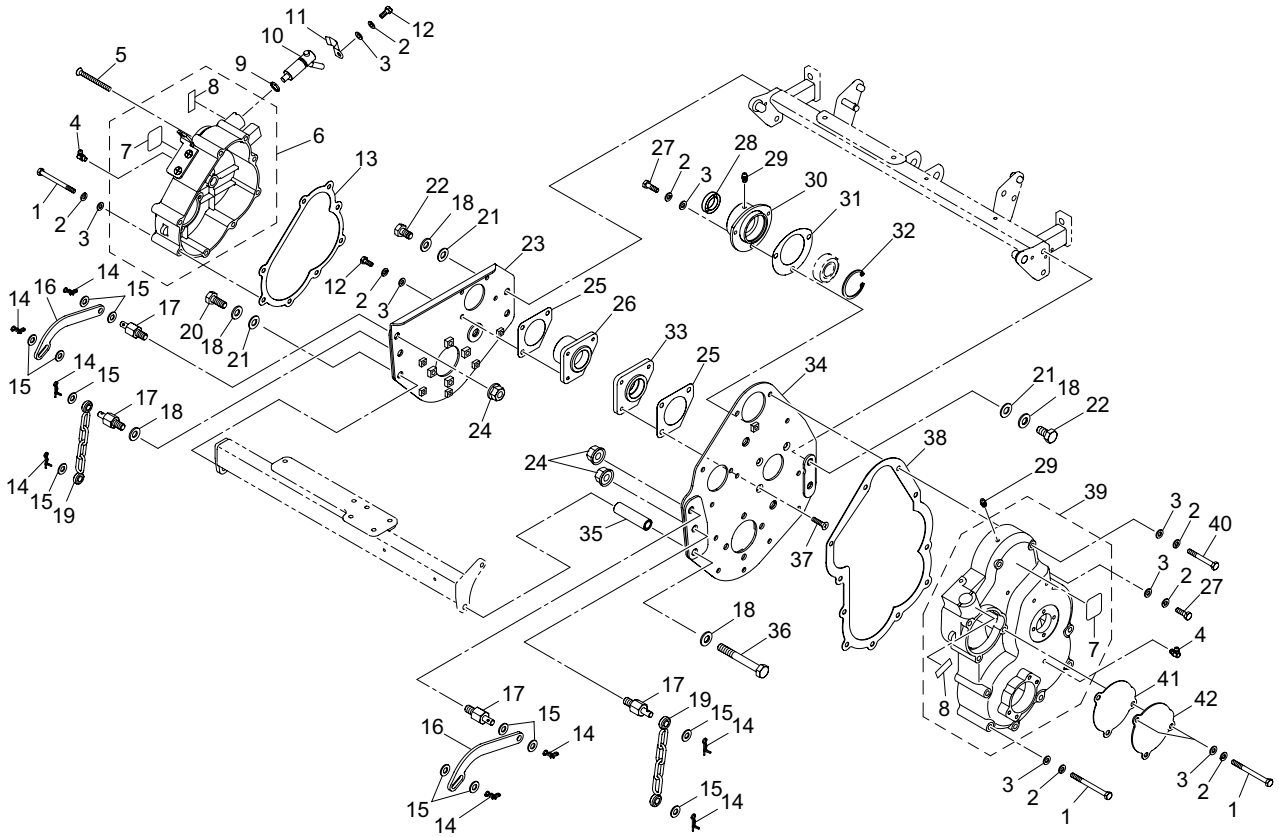

LM101_12_z01

| Cat No. | Code No. | Part name | Qty | Remark | SN of application |
|---------|---------------|----------------------------|-----|--------|-------------------|
| 12 - 31 | LM54G--0607Z0 | PACKING, #1 SHAFT | 1 | | |
| 12 - 32 | K0402040001 | RING, RETAINING R M40 | 1 | | |
| 12 - 33 | LM54G--0610ZD | HOUSING, DIFF (LH) | 1 | | |
| 12 - 34 | LM54G--0601B3 | FRAME, (LH) | 1 | | |
| 12 - 35 | K6212002643 | COLLAR, STKM M10.2-165-9.8 | 1 | | |
| 12 - 36 | K0000100802 | BOLT, M10-80 | 1 | | |
| 12 - 37 | K0041060122 | SCREW, + FLAT HEAD M6-12 | 3 | | |
| 12 - 38 | LM54G--0603A0 | PACKING, LARGE | 1 | | |
| 12 - 39 | LM101--0601Z0 | COVER, FRAME W/ DECAL (LH) | 1 | | |
| 12 - 40 | K0000060502 | BOLT, M6-50 | 2 | | |
| 12 - 41 | LM54G--0620Z0 | PACKING | 1 | | |
| 12 - 42 | LM54G--0619ZD | COVER | 1 | | |
| | | | | | |
| | | | | | |
| | | | | | |
| | | | | | |

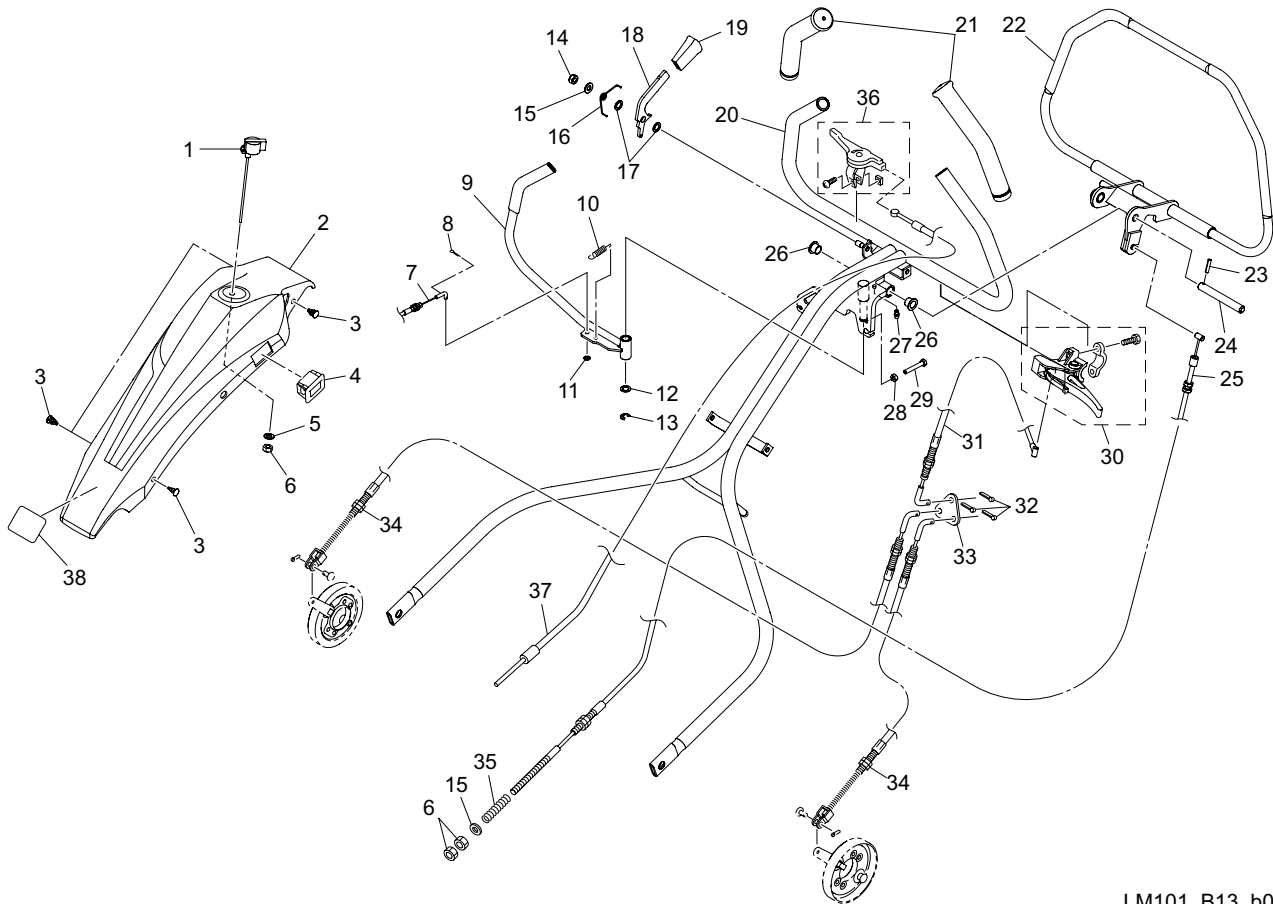

LM101_B13_b02

| Cat No. | Code No. | Part name | Qty | Remark | SN of application |
|----------|---------------|----------------------------|-----|--------|-------------------|
| B13 - 1 | K3662000050 | SWITCH, TOGGLE FOR ENGINE | 1 | | |
| B13 - 2 | LM56GC-3109A0 | COVER, HANDLE A | 1 | | 10470-10874 |
| B13a-2 | LM56GC-3109B0 | COVER, HANDLE A | 1 | | 10875- |
| B13 - 3 | K4021000010 | CLIP, ANCHOR 7.5 | 4 | | |
| B13 - 4 | K3650000090 | HOUR METER | 1 | | |
| B13 - 5 | K0200080002 | WASHER, SPRING M8 | 1 | | |
| B13 - 6 | K0100080002 | NUT, M8 | 3 | | |
| B13 - 7 | K1110090010 | WIRE, THROTTLE 900 | 1 | | |
| B13 - 8 | K0300016122 | PIN, COTTER M1.6-12 | 1 | | |
| B13 - 9 | LM56GC-3106ZD | LEVER, THROTTLE L | 1 | | |
| B13 - 10 | K1040000068 | SPRING, W/HOOK M1-10-52 | 1 | | |
| B13 - 11 | K5000050002 | WASHER, M5 | 1 | | |
| B13 - 12 | K5011011182 | WASHER, SPCC 1-11-18 | 1 | | |
| B13 - 13 | K0400008002 | RING, RETAINING E M8 | 1 | | |
| B13 - 14 | K0144080002 | NUT, W/F-RING M8 | 1 | | |
| B13 - 15 | K5000080002 | WASHER, M8 | 2 | | |
| B13 - 16 | K1050000258 | SPRING, TORSION M1.8-11.6 | 1 | | |
| B13 - 17 | K5051010160 | WASHER, C5191P 1-10-16 | 2 | | |
| B13 - 18 | LM56GC-3107Z2 | LEVER, LOCKING CLUTCH | 1 | | |
| B13 - 19 | K1301000130 | GRIP, PLASTIC SQUARE | 1 | | |
| B13 - 20 | LM101--3302AD | HANDLE, A 101 | 1 | | |
| B13 - 21 | K1300000250 | GRIP, PLASTIC BLACK 22-256 | 2 | | |
| B13 - 22 | LM56GC-3105ZD | LEVER, CLUTCH | 1 | | |
| B13 - 23 | K0320050221 | PIN, SPRING M5-22 | 1 | | |
| B13 - 24 | LM56GC-3108Z2 | SHAFT, W/HOLE 5 | 1 | | |
| B13 - 25 | K1130120000 | WIRE, CLUTCH 1200 | 1 | | |
| B13 - 26 | K6010000170 | BUSH, FLANGED 12-14-10 | 2 | | |
| B13 - 27 | K1440000070 | GREASE NIPPLE | 1 | | |
| B13 - 28 | K0100060002 | NUT, M6 | 1 | | |
| B13 - 29 | K0000060402 | BOLT, M6-40 | 1 | | |

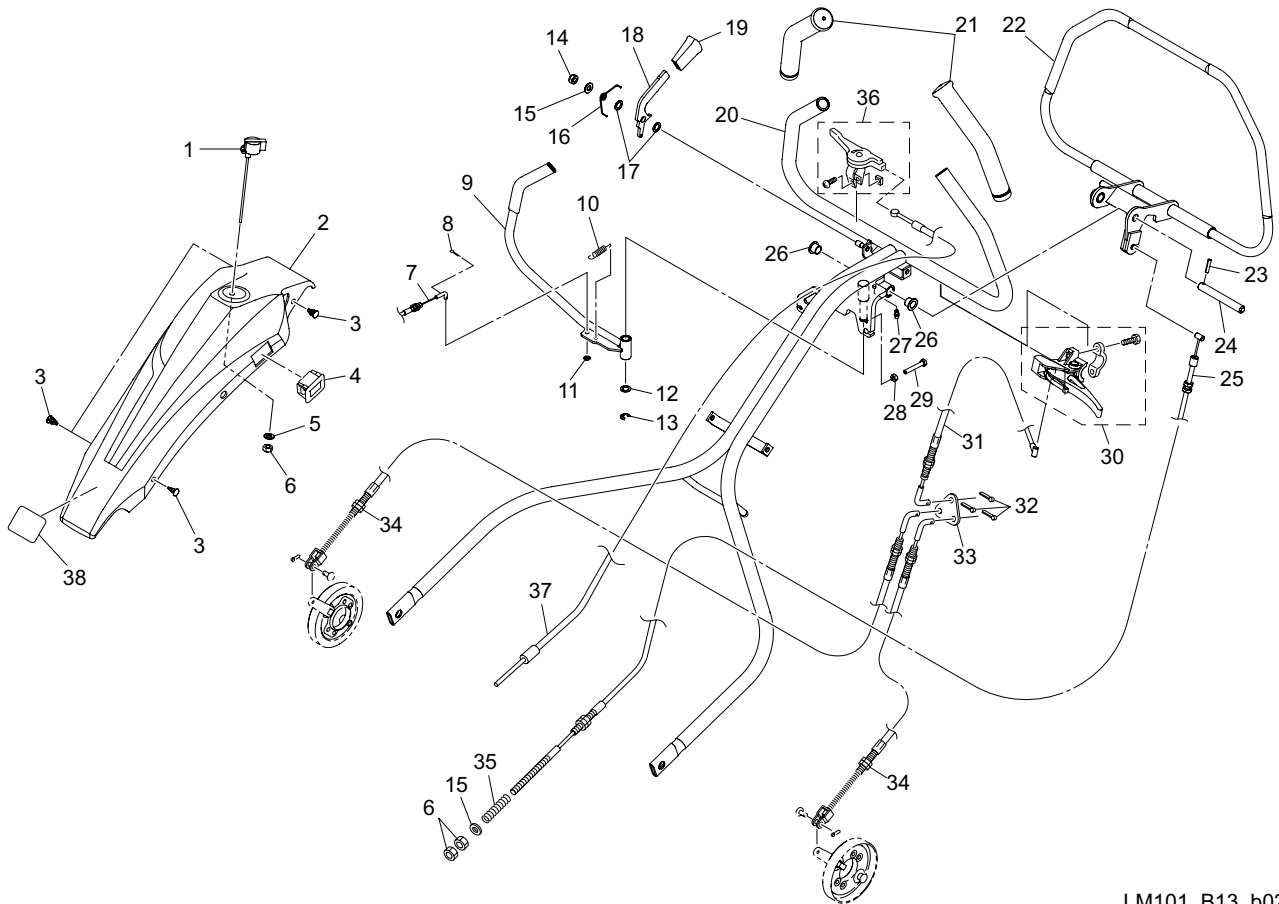

LM101_B13_b02

| Cat No. | Code No. | Part name | Qty | Remark | SN of application |
|----------|---------------|----------------------------------|-----|-----------|-------------------|
| B13 - 30 | K1211380040 | LEVER, CLUTCH E138004 | 1 | | |
| B13 - 31 | K1120042010 | WIRE, BRAKE 420 | 1 | | |
| B13 - 32 | K0300020122 | PIN, COTTER M2-12 | 3 | | |
| B13 - 33 | LM54GB-1101Z2 | CONNECTOR, WIRE | 1 | | |
| B13 - 34 | K1120095300 | WIRE, BRAKE 953 | 2 | | |
| B13 - 35 | K100000082D | SPRING, COMPRESSION M2.6-17.2-70 | 1 | | |
| B13 - 36 | K1203522000 | LEVER, THROTTLE E352200 | 1 | Accessory | |
| B13 - 37 | K1110117010 | WIRE, THROTTLE 1170S | 1 | Accessory | |
| B13 - 38 | K4201000590 | DECAL, K | 1 | | 10826- |
| | | | | | |
| | | | | | |
| | | | | | |
| | | | | | |

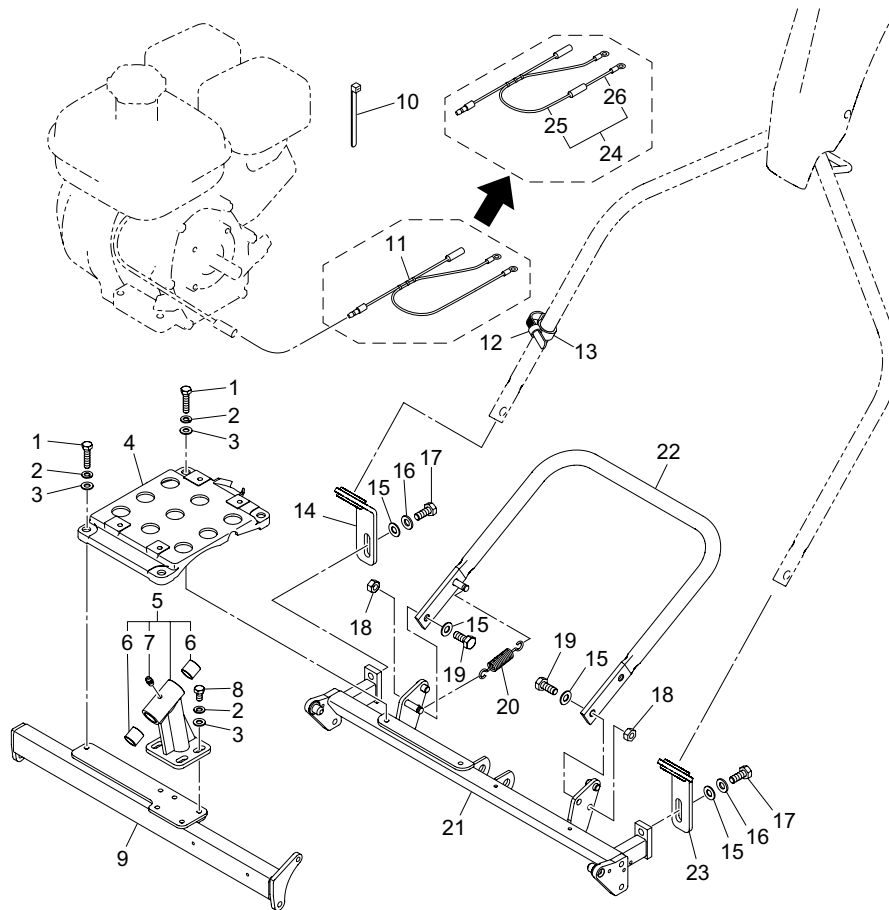

LM101_14_a02

| Cat No. | Code No. | Part name | Qty | Remark | SN of application |
|---------|---------------|-----------------------------------|-----|--------|-------------------|
| 14 - 1 | K0000080302 | BOLT, M8-30 | 4 | | |
| 14 - 2 | K0200080002 | WASHER, SPRING M8 | 8 | | |
| 14 - 3 | K5000080002 | WASHER, M8 | 8 | | |
| 14 - 4 | LM54GA-0727A0 | BASE, ENGINE 106 | 1 | | |
| 14 - 5 | LM54G--0719CD | HITCH, MOUNTING ARM | 1 | | |
| 14 - 6 | K6000000240 | BUSH, 17-20-19 | 2 | | |
| 14 - 7 | K1440000010 | GREASE NIPPLE, STRAIGHT TYPE A | 1 | | |
| 14 - 8 | K0000080152 | BOLT, M8-15 | 4 | | |
| 14 - 9 | LM54G--0713ZR | STAY, FRAME FRONT | 1 | | |
| 14 - 10 | K4241000040 | BAND, PLASTIC TRCV-200W | 1 | | |
| 14a- 11 | K3620000550 | LINE, ENGINE SWITCH 8A | 1 | | 10470-10875 |
| 14 - 12 | K4241000070 | TUBE, URETHANE 7 | 3 | | |
| 14 - 13 | K4241000010 | BAND, NYLON 140 | 3 | | |
| 14 - 14 | LM55GB-0716E0 | ADJUSTER, HANDLE (RH) | 1 | | |
| 14 - 15 | K5000100002 | WASHER, M10 | 4 | | |
| 14 - 16 | K0213100002 | WASHER, DISK SPRING 1H M10 | 2 | | |
| 14 - 17 | K0010100252 | BOLT, HT M10-25 | 2 | | |
| 14 - 18 | K0100100002 | NUT, M10 | 2 | | |
| 14 - 19 | K0000100252 | BOLT, M10-25 | 2 | | |
| 14 - 20 | K1020000198 | SPRING, W/ROUND HOOK M2.6-15.5-84 | 1 | | |
| 14 - 21 | LM101--0714ZR | STAY, REAR FRAME | 1 | | |
| 14 - 22 | LM56G--0708AD | STAND | 1 | | |
| 14 - 23 | LM55GB-0715E0 | ADJUSTER, HANDLE (LH) | 1 | | |
| 14 - 24 | K3620001160 | LINE, ENGINE SWITCH 8C | 1 | | 10876- |
| 14 - 25 | K3620001170 | LINE, ENGINE SWITCH | 1 | | 10876- |
| 14 - 26 | K3620001180 | LINE, BRACK 160 | 1 | | 10876- |

15. Grass catcher section

LM101

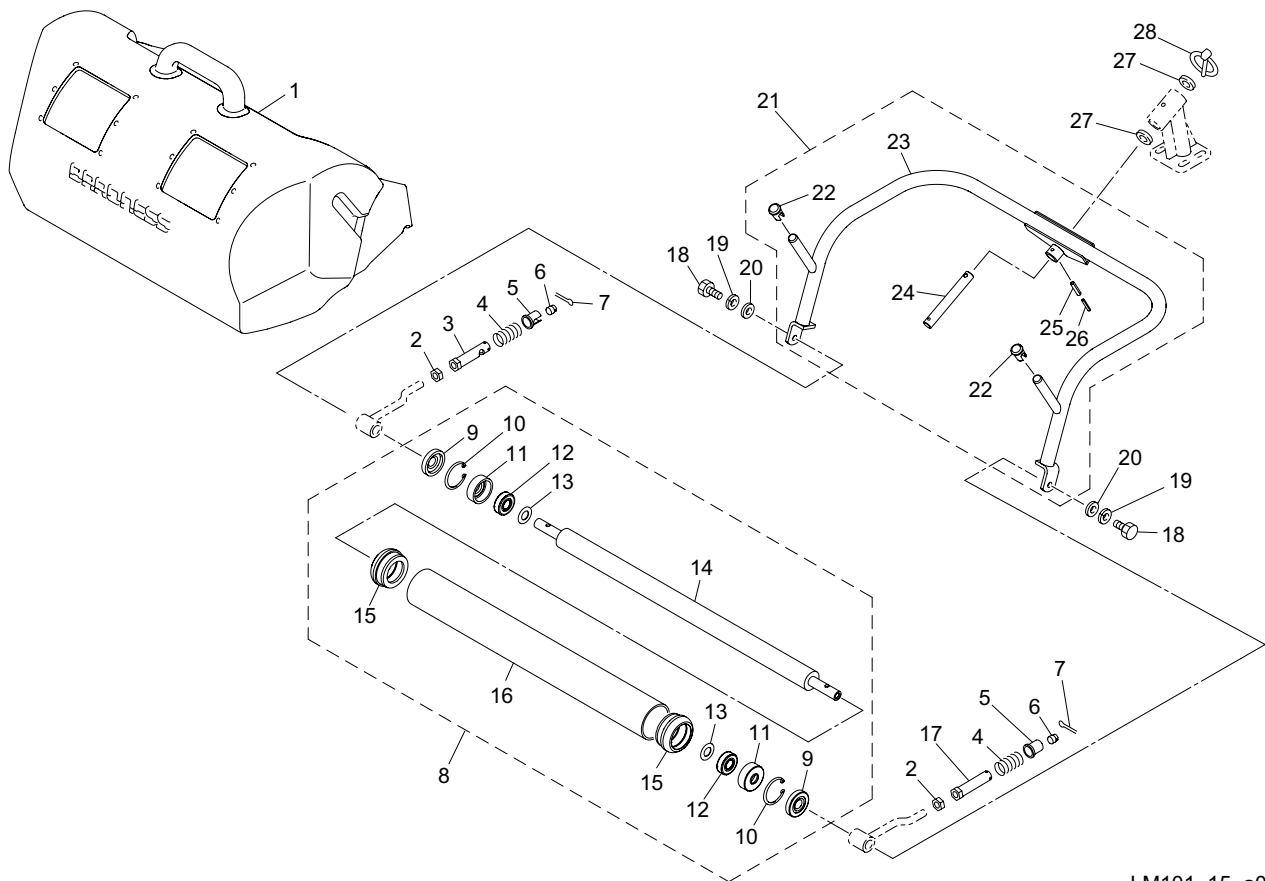

LM101_15_a00

| Cat No. | Code No. | Part name | Qty | Remark | SN of application |
|---------|---------------|--------------------------------|-----|--------|-------------------|
| 15 - 1 | LM101--0820A0 | GRASS CATCHER COMP | 1 | | |
| 15 - 2 | K0160000282 | NUT, P1 OH1 M10-3 | 2 | | |
| 15 - 3 | LM54G--0805Z9 | PIPE, (RH) | 1 | | |
| 15 - 4 | K1000000678 | SPRING, COMPRESSION M1-18-43 | 2 | | |
| 15 - 5 | LM54G--0808Z9 | STOPPER | 2 | | |
| 15 - 6 | LM54G--0806Z3 | SCREW, RETAINING | 2 | | |
| 15 - 7 | K0302025250 | PIN, COTTER SUS M2.5-25 | 2 | | |
| 15a- 8 | LM54G--0810B0 | ROLLER ASSY, 590 | 1 | | 10470-10935 |
| 15b- 8 | LM101--4101Z0 | ROLLER ASSY, 590 | 1 | | 10936-11035 |
| 15c- 8 | LM101--4105Z0 | ROLLER ASSY, 590 | 1 | | 11036- |
| 15 - 9 | K0861000020 | OIL SEAL, TA1542.38 | 2 | | |
| 15 - 10 | K0402042001 | RING, RETAINING R M42 | 2 | | |
| 15 - 11 | K0861000030 | OIL SEAL, 6202 | 2 | | |
| 15 - 12 | K0616062020 | BEARING, BALL SEAL 2NSEC3 6202 | 2 | | |
| 15a- 13 | K5051015280 | WASHER, C5191P 1-15-28 | 2 | | 10470-11035 |
| 15a- 14 | K6131000060 | SHAFT, ROLLER 651 | 1 | | 10470-10935 |
| 15b- 14 | LM101--4102Z2 | SHAFT, ROLLER 651 | 1 | | 10936-11035 |
| 15c- 14 | LM101--4106Z2 | SHAFT, ROLLER 651 | 1 | | 11036- |
| 15 - 15 | LM54GA-0812A0 | HOUSING, ROLLER 60 | 2 | | |
| 15 - 16 | K6226000100 | PIPE, ROLLER M55-605-60 | 1 | | |
| 15 - 17 | LM54G--0804Z9 | PIPE, (LH) | 1 | | |
| 15 - 18 | K0000100302 | BOLT, M10-30 | 2 | | |
| 15 - 19 | K0200100002 | WASHER, SPRING M10 | 2 | | |
| 15 - 20 | K5000100002 | WASHER, M10 | 2 | | |
| 15 - 21 | LM54G--0822Z0 | BRACKET COMP, GRASS CATCHER | 1 | | |
| 15 - 22 | K1310000060 | CAP, 12.7 | 2 | | |
| 15 - 23 | LM54G--0824Z0 | BRACKET, GRASS CATCHER | 1 | | |
| 15 - 24 | LM54G--0825A8 | SHAFT, ARM | 1 | | |
| 15 - 25 | K0320050251 | PIN, SPRING M5-25 | 1 | | |
| 15 - 26 | K0320030251 | PIN, SPRING M3-25 | 1 | | |

15. Grass catcher section

LM101

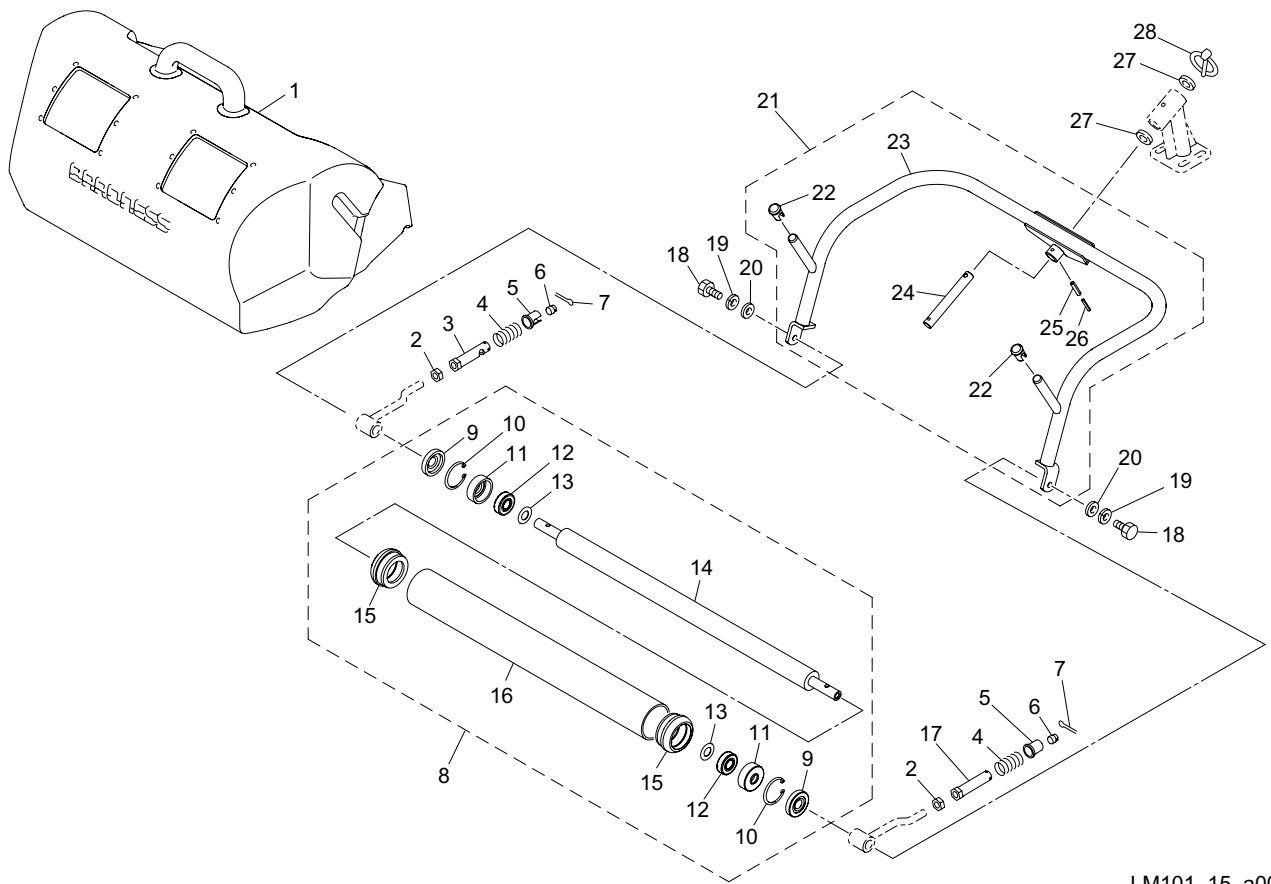

LM101_15_a00

| Cat No. | Code No. | Part name | Qty | Remark | SN of application |
|---------|-------------|------------------------|-----|--------|-------------------|
| 15 - 27 | K5051017280 | WASHER, C5191P 1-17-28 | 2 | | |
| 15 - 28 | K6061060002 | PIN, CLIP M6 | 1 | | |
| | | | | | |
| | | | | | |
| | | | | | |
| | | | | | |
| | | | | | |
| | | | | | |
| | | | | | |

16. Brake section

LM101

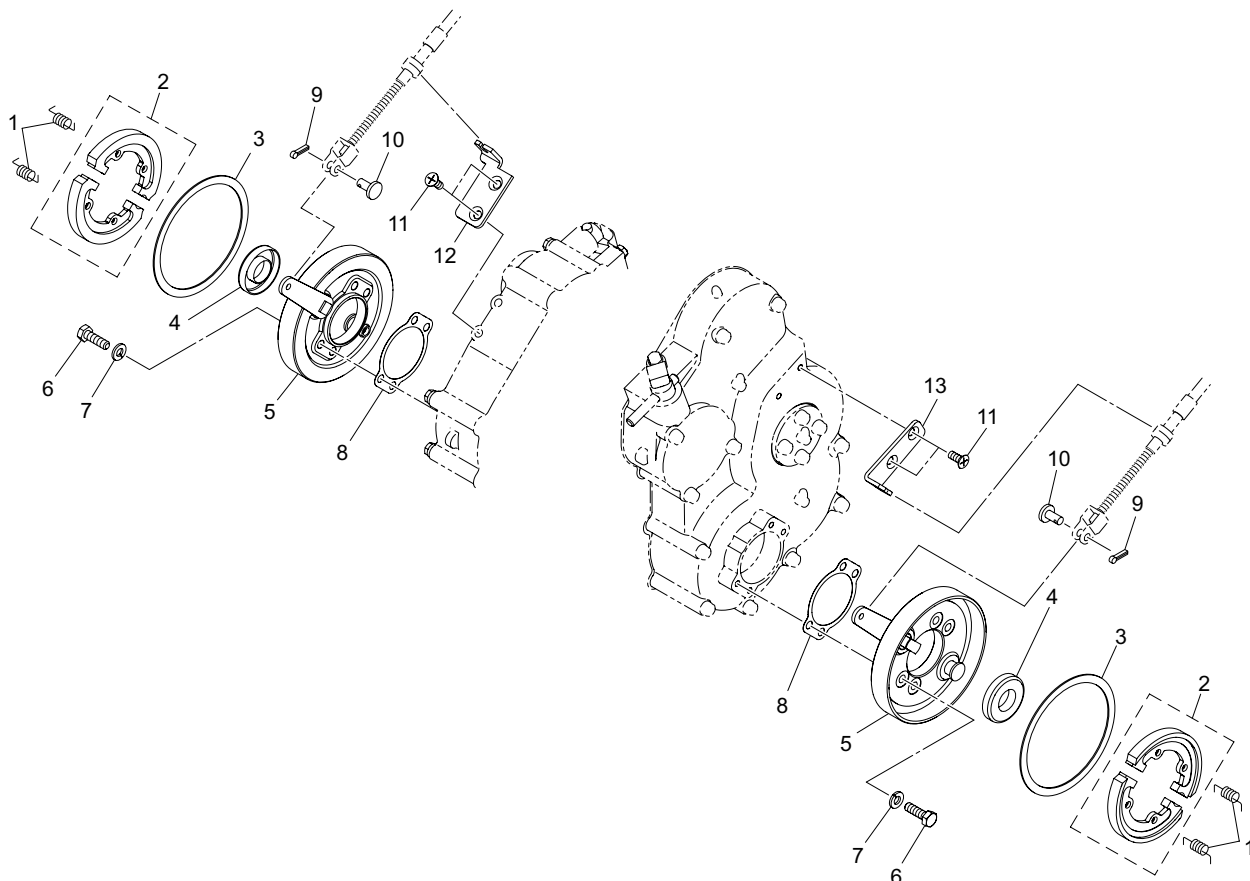

LM101_16_z00

| Cat No. | Code No. | Part name | Qty | Remark | SN of application |
|---------|---------------|--------------------------|-----|--------|-------------------|
| 16 - 1 | K1040000010 | SPRING, W/HOOK M1.6-8-45 | 4 | | |
| 16 - 2 | K1725000040 | SHOE ASSY, BRAKE 100 | 2 | | |
| 16 - 3 | K4009000010 | PACKING, FELT 1-96-110 | 2 | | |
| 16 - 4 | K0852042080 | OIL SEAL, PJN20428 | 2 | | |
| 16 - 5 | LM55GB-1102Z2 | PLATE, MOUNTING BRAKE | 2 | | |
| 16 - 6 | K0000060202 | BOLT, M6-20 | 8 | | |
| 16 - 7 | K0200060002 | WASHER, SPRING M6 | 8 | | |
| 16 - 8 | LM55GB-1101Z0 | PACKING | 2 | | |
| 16 - 9 | K0300020202 | PIN, COTTER M2-20 | 2 | | |
| 16 - 10 | K6030050152 | PIN, FLAT HEAD M5-15 | 2 | | |
| 16 - 11 | K0041060152 | SCREW, + FLAT HEAD M6-15 | 4 | | |
| 16 - 12 | LM54G--1112Z3 | BRACKET, BRAKE WIRE (RH) | 1 | | |
| 16 - 13 | LM55GB-1113A3 | BRACKET, BRAKE WIRE (LH) | 1 | | |
| | | | | | |
| | | | | | |
| | | | | | |
| | | | | | |

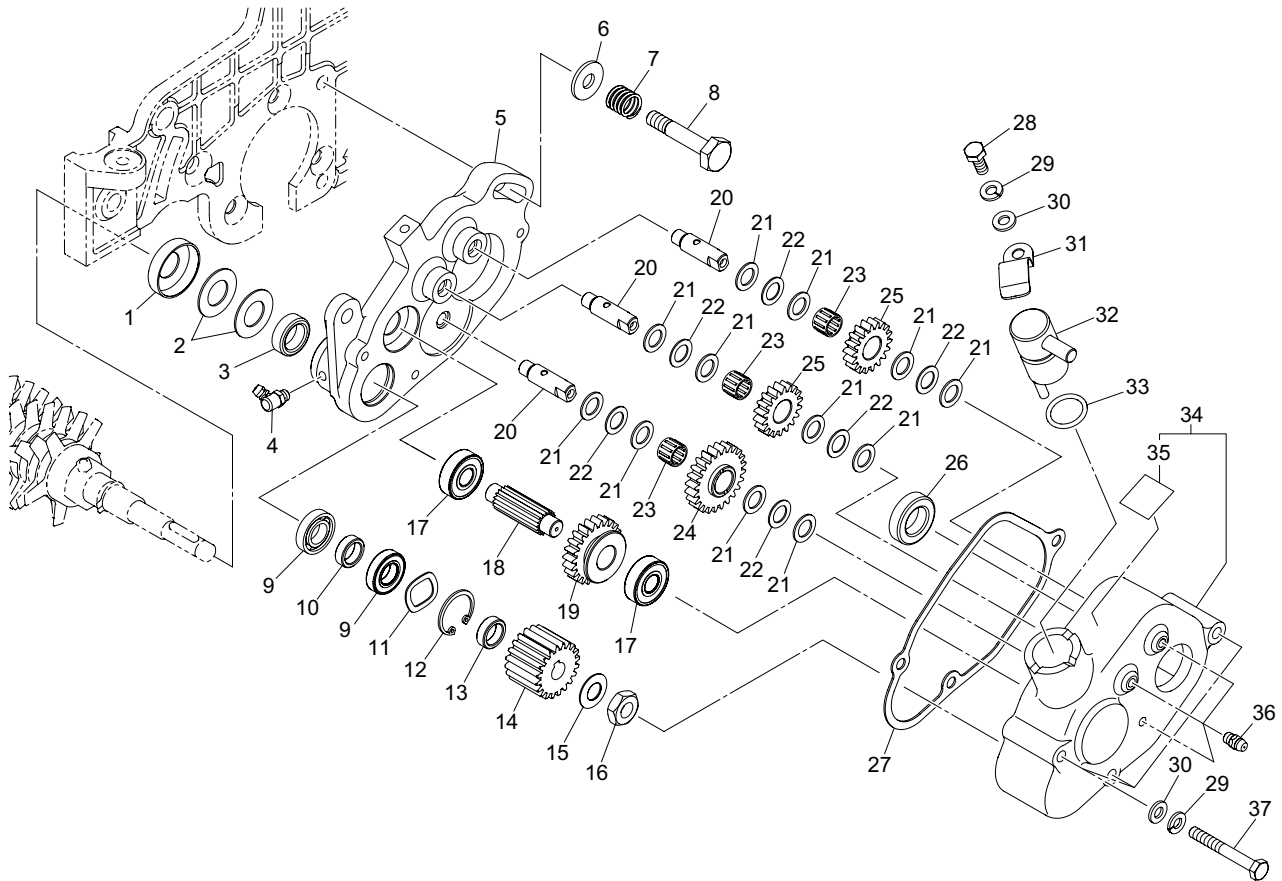

LM101_17_z00

| Cat No. | Code No. | Part name | Qty | Remark | SN of application |
|---------|---------------|----------------------------------|-----|--------|-------------------|
| 17 - 1 | K5300000293 | COVER, DUST PROOF | 1 | | |
| 17 - 2 | K5051015280 | WASHER, C5191P 1-15-28 | 2 | | |
| 17 - 3 | K0821522070 | OIL SEAL, MHSA15227 | 1 | | |
| 17 - 4 | K1440000030 | GREASE NIPPLE, 67.5 TYPE B | 1 | | |
| 17 - 5 | LM101--1201Z0 | GEARCASE | 1 | | 10470-10825 |
| 17a- 5 | LM101--1201A0 | GEARCASE | 1 | | 10826- |
| 17 - 6 | K5090000250 | WASHER, C5191P 2-8.5-22 | 1 | | |
| 17 - 7 | K1000000309 | SPRING, COMPRESSION M1.6-13.7-20 | 1 | | |
| 17 - 8 | LM54GAS1230Z3 | BOLT, CLAMPING CASE (LH) | 1 | | |
| 17 - 9 | K0611069010 | BEARING, BALL SEAL RDC3 6901 | 2 | | |
| 17 - 10 | K6212002630 | COLLAR, STKM M12.1-17-5.6 | 1 | | |
| 17 - 11 | K0220160110 | WASHER, WAVE 16011 | 1 | | |
| 17 - 12 | K0402024001 | RING, RETAINING R M24 | 1 | | |
| 17 - 13 | K6212001910 | COLLAR, STKM M12.1-17-6 | 1 | | |
| 17 - 14 | LM101--1204Z0 | GEAR, 20-TEETH | 1 | | |
| 17 - 15 | K0210100002 | SPRING, CONICAL DISC L M10 | 1 | | |
| 17 - 16 | K0160000282 | NUT, P1 OH1 M10-3 | 1 | | |
| 17 - 17 | K0608060000 | BEARING, BALL SEAL 2RS 6000 | 2 | | |
| 17 - 18 | K6100000100 | SHAFT, CLUTCH | 1 | | |
| 17 - 19 | K6180000150 | GEAR, SPLINED 23-TEETH | 1 | | |
| 17 - 20 | K6120000310 | COUNTERSHAFT, THREADED | 3 | | |
| 17 - 21 | K5051010160 | WASHER, C5191P 1-10-16 | 12 | | |
| 17 - 22 | K5020810160 | WASHER, NBS55 0.8-10-16 | 6 | | |
| 17 - 23 | K0701013100 | BEARING, NEEDLE KT101310EGB2 | 3 | | |
| 17 - 24 | K6186000050 | GEAR, 24-TEETH | 1 | | |
| 17 - 25 | K6186000040 | GEAR, 18-TEETH B | 2 | | |
| 17 - 26 | K0821628070 | OIL SEAL, MHSA16287 | 1 | | |
| 17 - 27 | LM101--1203Z0 | PACKING, GEARCASE | 1 | | |
| 17 - 28 | K0000060102 | BOLT, M6-10 | 1 | | |
| 17 - 29 | K0200060002 | WASHER, SPRING M6 | 4 | | |

17. Groomer section A

LM101

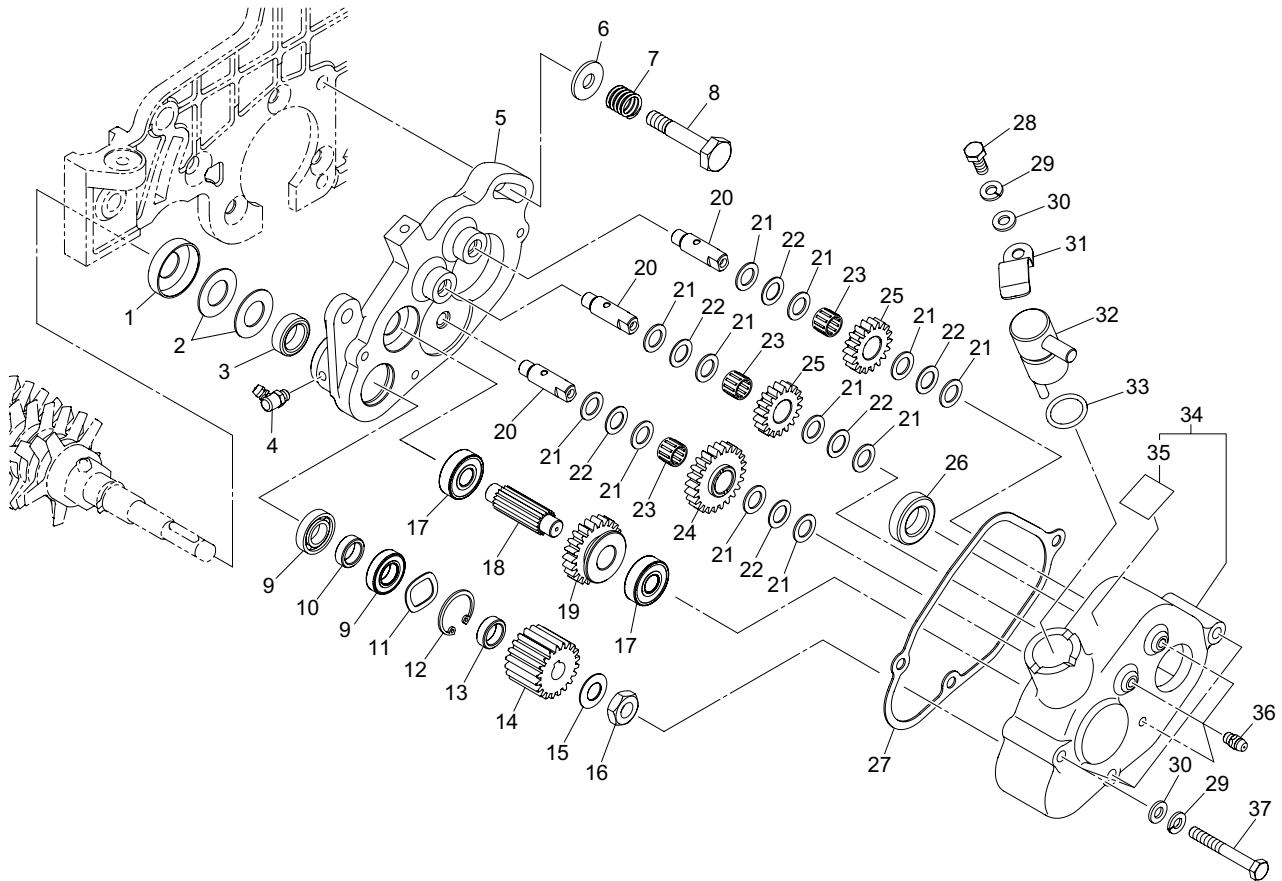

LM101_17_z00

| Cat No. | Code No. | Part name | Qty | Remark | SN of application |
|---------|---------------|--------------------------------|-----|--------|-------------------|
| 17 - 30 | K5000060002 | WASHER, M6 | 4 | | |
| 17 - 31 | K1090000058 | SPRING, CLUTCH RETAINER | 1 | | |
| 17 - 32 | LM101--1207Z8 | LEVER, CLUTCH | 1 | | |
| 17 - 33 | K0880018000 | O-RING, P18 | 1 | | |
| 17 - 34 | LM101--1251Z0 | COVER, GEARCASE W/ DECAL | 1 | | |
| 17 - 35 | K4203001120 | DECAL, INDICATION GROOMER | 1 | | |
| 17 - 36 | K1440000010 | GREASE NIPPLE, STRAIGHT TYPE A | 3 | | |
| 17 - 37 | K0000060502 | BOLT, M6-50 | 3 | | |
| | | | | | |
| | | | | | |
| | | | | | |
| | | | | | |
| | | | | | |

18. Groomer section B

LM101

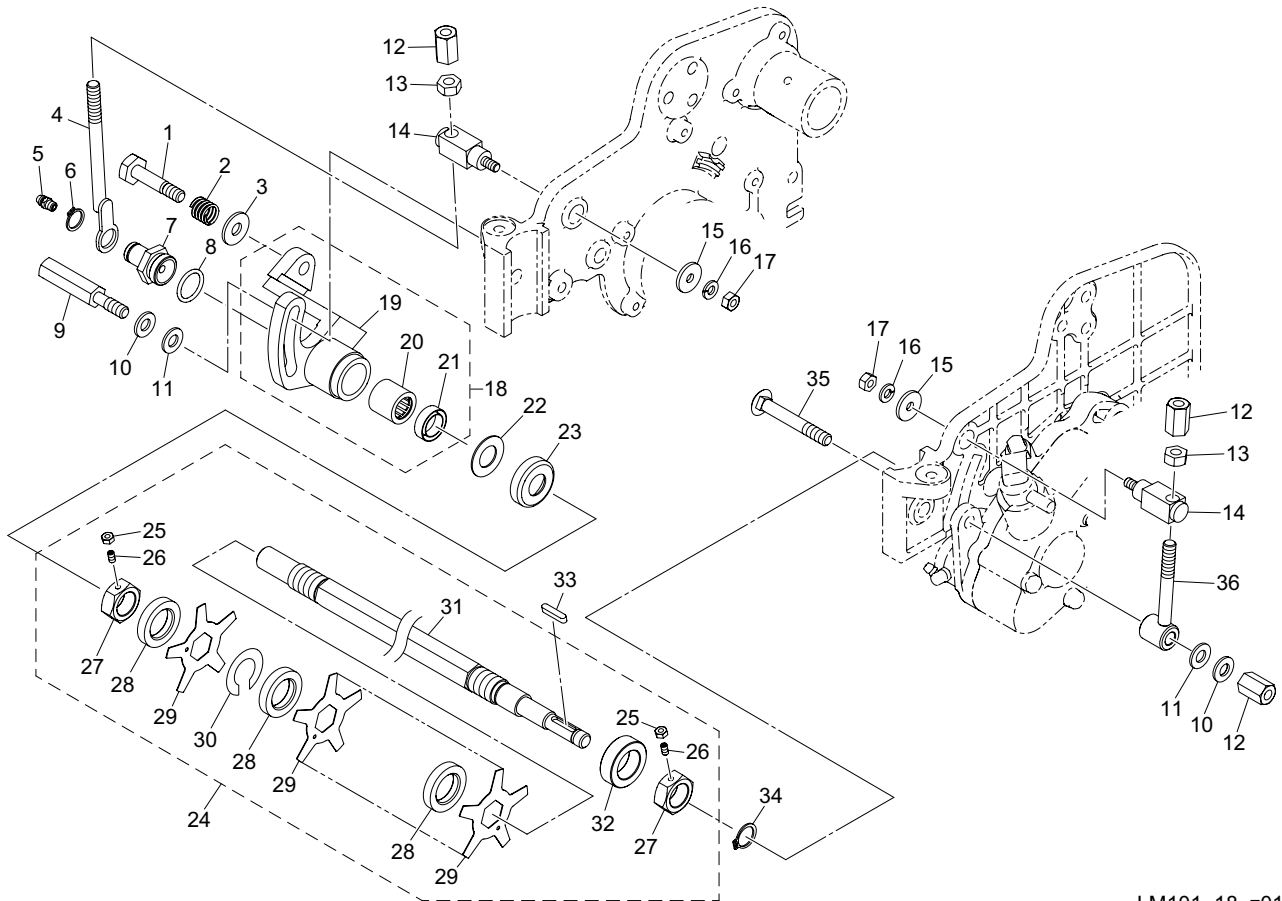

LM101_18_z01

| Cat No. | Code No. | Part name | Qty | Remark | SN of application |
|---------|---------------|-----------------------------------|------|----------------|-------------------|
| 18 - 1 | K6083000143 | PIN, STEPPED FOR FIXING (RH) CASE | 1 | | |
| 18 - 2 | K1000000309 | SPRING, COMPRESSION M1.6-13.7-20 | 1 | | |
| 18 - 3 | K5090000250 | WASHER, C5191P 2-8.5-22 | 1 | | |
| 18 - 4 | LM54GS-1229A3 | SCREW, MOUNTING | 1 | | |
| 18 - 5 | K1440000010 | GREASE NIPPLE, STRAIGHT TYPE A | 1 | | |
| 18 - 6 | K0401013001 | RING, RETAINING S M13 | 1 | | |
| 18 - 7 | K6084000192 | SCREW | 1 | | |
| 18 - 8 | K0880018000 | O-RING, P18 | 1 | | |
| 18 - 9 | K6081000062 | BOLT, 45 | 1 | | |
| 18 - 10 | K0213080002 | WASHER, DISK SPRING 1H M8 | 2 | | |
| 18 - 11 | K5000080002 | WASHER, M8 | 2 | | |
| 18 - 12 | K0149083202 | NUT, HIGH M8-13-20 | 3 | | |
| 18 - 13 | K0100080002 | NUT, M8 | 2 | | |
| 18 - 14 | LM54GAS1227Z3 | ADJUSTER | 2 | | |
| 18 - 15 | K5012306202 | WASHER, SPCC 2.3-6-20 | 2 | | |
| 18 - 16 | K0200060002 | WASHER, SPRING M6 | 2 | | |
| 18 - 17 | K0100060002 | NUT, M6 | 2 | | |
| 18 - 18 | LM101--1253Z0 | HOUSING ASSY, VERTICAL (RH) | 1 | | |
| 18 - 19 | LM54GS-1207A0 | HOUSING, VERTICAL (RH) | 1 | | |
| 18 - 20 | K0721520000 | BEARING, NEEDLE TA 1520 Z | 1 | | |
| 18 - 21 | K0821522070 | OIL SEAL, MHSA15227 | 1 | | |
| 18 - 22 | K5051015280 | WASHER, C5191P 1-15-28 | 1 | | |
| 18 - 23 | K5300000293 | COVER, DUST PROOF | 1 | | |
| 18 - 24 | LM101--1252Z0 | GROOMER COMP, 77 | 1 | | |
| 18 - 25 | K0100040002 | NUT, M4 | 2 | | |
| 18 - 26 | K0023000041 | SETSCREW, M4-8 | 2 | | |
| 18 - 27 | K0160000602 | NUT, SPECIAL P1 M17 W/M4 | 2 | | |
| 18 - 28 | K6214000030 | COLLAR, AC M19.7-32-6.1 | 77 | | |
| 18 - 29 | K2570000019 | BLADE, VERTICAL 63 | 77 | | |
| 18 - 30 | K5090000673 | WASHER, SPCC 0.5 | 0~10 | for adjustment | |

18. Groomer section B

LM101

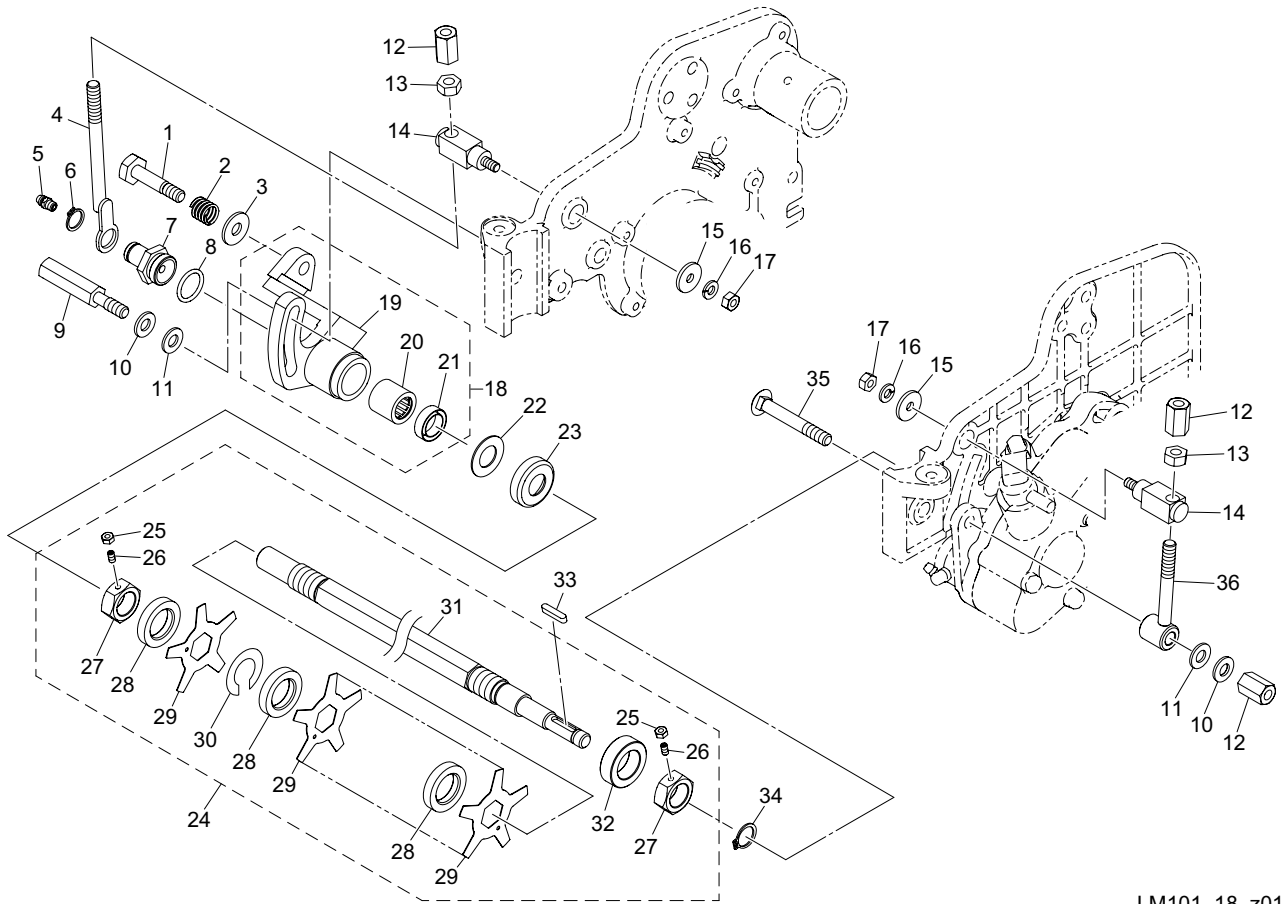

LM101_18_z01

| Cat No. | Code No. | Part name | Qty | Remark | SN of application |
|---------|---------------|------------------------|-----|--------|-------------------|
| 18 - 31 | LM101--1208Z8 | SHAFT, VERTICAL | 1 | | |
| 18 - 32 | LM55GBS1204Z0 | COLLAR | 1 | | |
| 18 - 33 | K0500404200 | KEY, BOTH ROUND M4-420 | 1 | | |
| 18 - 34 | K0401015001 | RING, RETAINING S M15 | 1 | | |
| 18 - 35 | K0025080552 | BOLT,CARRIAGE M8-55 | 1 | | |
| 18 - 36 | LM54GS-1220A3 | STOPPER, (LH) | 1 | | |
| | | | | | |
| | | | | | |
| | | | | | |
| | | | | | |
| | | | | | |

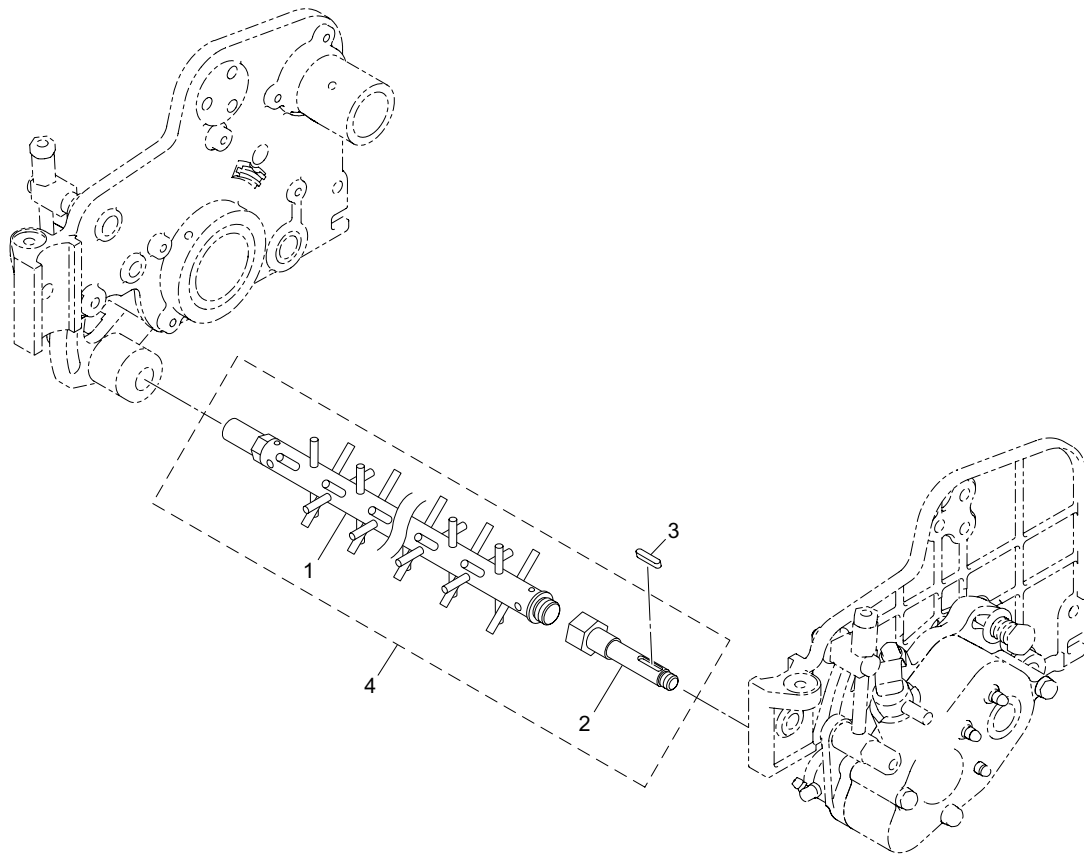

LM101_19_z01

| Cat No. | Code No. | Part name | Qty | Remark | SN of application |
|---------|---------------|------------------------|-----|--------|-------------------|
| 19 - 1 | K4150000010 | SHAFT ASSY, BRUSH 15 | 1 | | |
| 19 - 2 | LM101--1301Z8 | SHAFT, BRUSH SMALL | 1 | | |
| 19 - 3 | K0500404200 | KEY, BOTH ROUND M4-420 | 1 | | |
| 19 - 4 | LM101--1310Z0 | BRUSH ASSY, W/SHAFT | 1 | | |
| | | | | | |
| | | | | | |
| | | | | | |
| | | | | | |
| | | | | | |
| | | | | | |
| | | | | | |

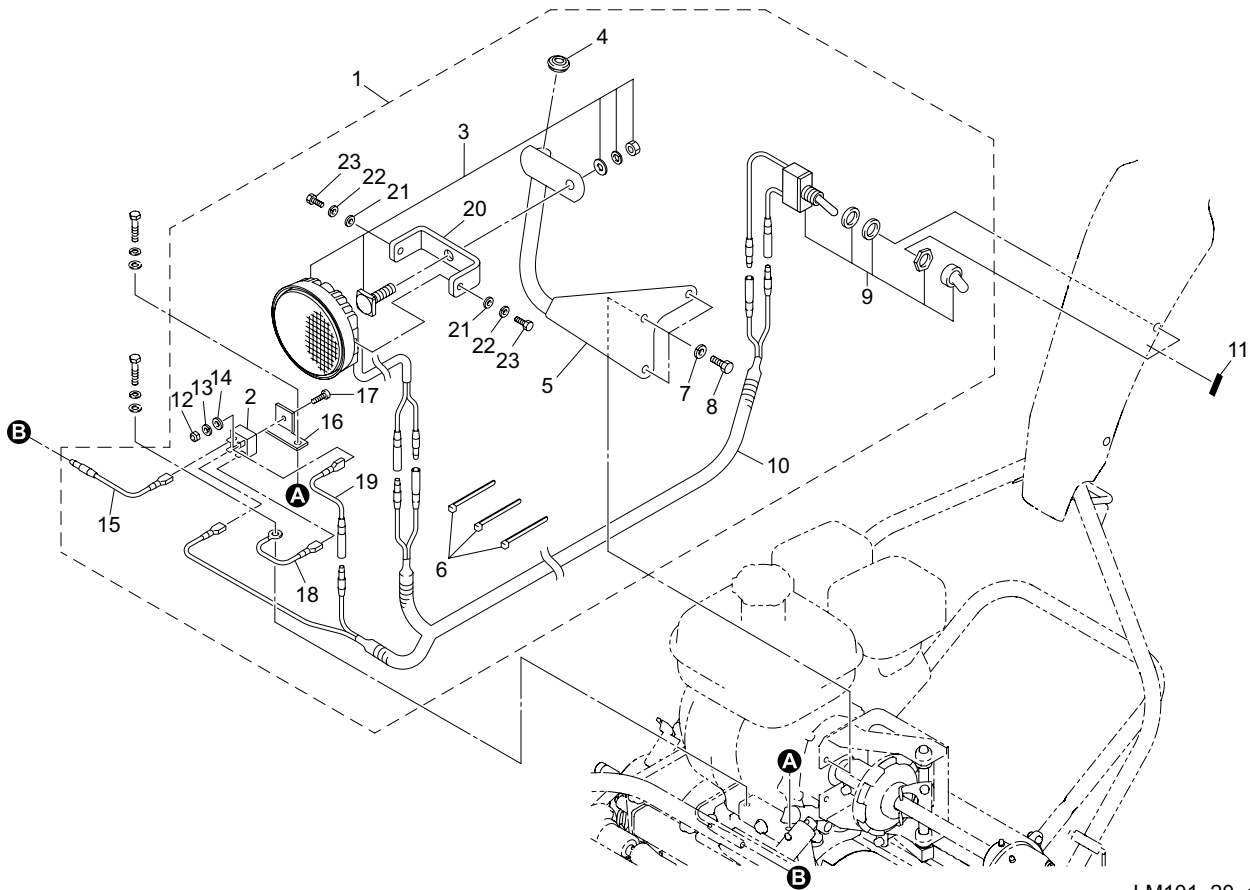

LM101_20_a02

| Cat No. | Code No. | Part name | Qty | Remark | SN of application |
|---------|---------------|----------------------------------|-----|--------|-------------------|
| 20a- 1 | LM101--2350Z0 | LIGHT KIT, LED | 1 | | |
| 20a- 2 | K3730000030 | DIODE, BRIDGE S15VB60 | 1 | | |
| 20 - 3 | K3640000090 | LAMP, LED WORKING NS-2556 | 1 | | |
| 20 - 4 | K0900300140 | GROMMET, W/SEALING C30SG14A | 1 | | |
| 20 - 5 | K735500071D | BRACKET, HEAD LAMP | 1 | | |
| 20 - 6 | K4241000060 | BAND, PLASTIC TRCV-160LW | 3 | | |
| 20 - 7 | K0200080002 | WASHER, SPRING M8 | 3 | | |
| 20 - 8 | K0000080202 | BOLT, M8-20 | 3 | | |
| 20 - 9 | K3662000100 | SWITCH, TOGGLE FOR LAMP WD101181 | 1 | | |
| 20a- 10 | K3620001120 | WIRE, SWITCH | 1 | | |
| 20 - 11 | K4203001610 | DECAL, LIGHT SWITCH | 1 | | |
| 20a- 12 | K0144040002 | NUT, W/F-RING M4 | 1 | | |
| 20a- 13 | K0200040002 | WASHER, SPRING M4 | 1 | | |
| 20a- 14 | K5000040002 | WASHER, M4 | 1 | | |
| 20a- 15 | LM101--2303Z0 | WIRE, 80 | 1 | | |
| 20a- 16 | LM101--2301Z2 | BRACKET, RECTIFIER | 1 | | |
| 20a- 17 | K0042040202 | SCREW, + ROUND HEAD M4-20 | 1 | | |
| 20a- 18 | LM101--2302Z0 | WIRE, BLACK | 1 | | |
| 20a- 19 | LM101--2304Z0 | WIRE, 100 | 1 | | |
| 20 - 20 | LM101--2305ZD | BRACKET, HEAD LAMP | 1 | | |
| 20 - 21 | K5000050002 | WASHER, M5 | 2 | | |
| 20 - 22 | K0200050002 | WASHER, SPRING M5 | 2 | | |
| 20 - 23 | K0000050152 | BOLT, M5-15 | 2 | | |
| 20a- 24 | | | | | |

21. Cutting section A (with Groomer)

LM101

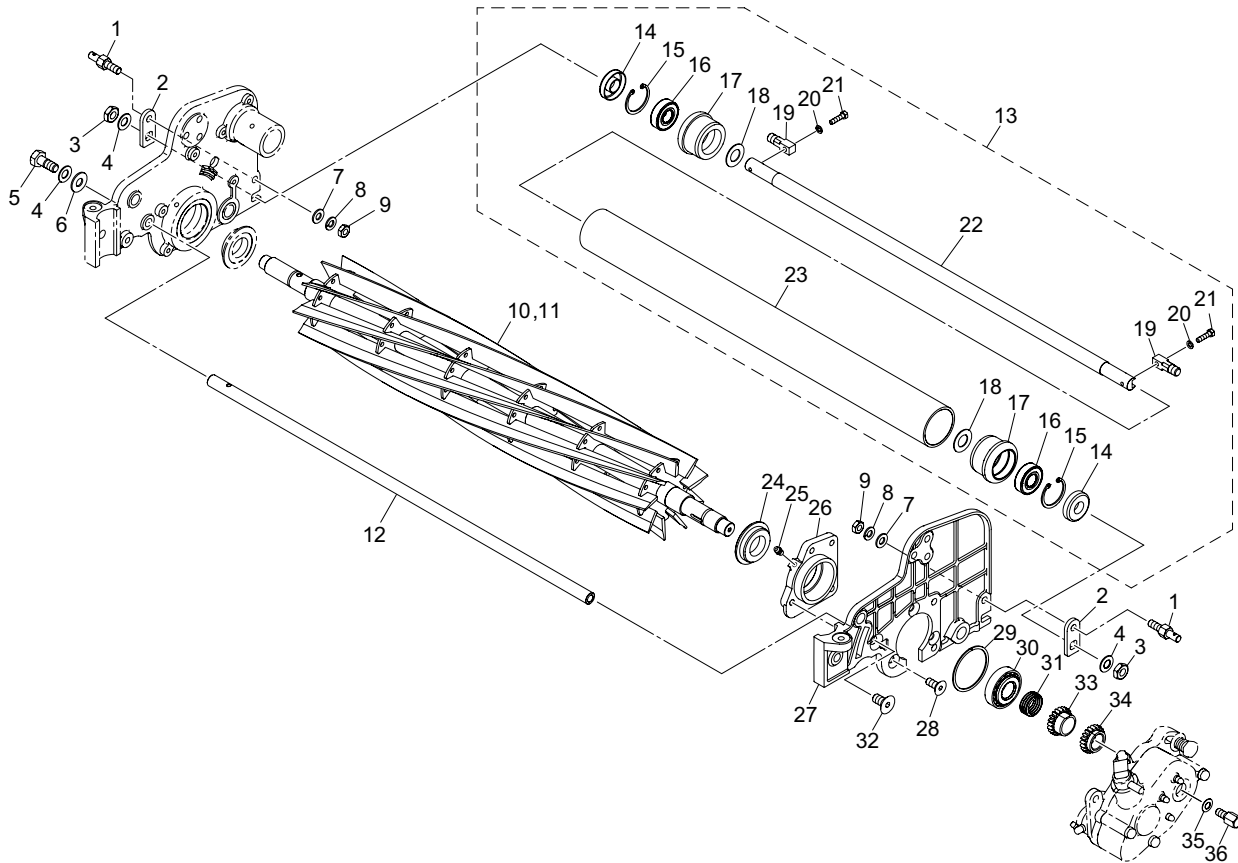

LM101_21_z00

| Cat No. | Code No. | Part name | Qty | Remark | SN of application |
|---------|---------------|-----------------------------------|-----|-----------|-------------------|
| 21 - 1 | LM54GA-0149Z3 | BOLT, 45 | 2 | | |
| 21 - 2 | LM101--0148Z2 | STOPPER | 2 | | |
| 21 - 3 | K0160000282 | NUT, P1 OH1 M10-3 | 2 | | |
| 21 - 4 | K0211100001 | SPRING, CONICAL DISC H M10 | 3 | | |
| 21 - 5 | LM54GA-0115A3 | BOLT, KNOCK 25 | 1 | | |
| 21 - 6 | K5001100002 | WASHER, M10-24 | 1 | | |
| 21 - 7 | K5000080002 | WASHER, M8 | 2 | | |
| 21 - 8 | K0200080002 | WASHER, SPRING M8 | 2 | | |
| 21 - 9 | K0102080002 | NUT, M8-3 | 2 | | |
| 21 - 10 | K280540090R | REEL CUTTER, 557 | 1 | 9 blades | |
| 21 - 11 | K280540110R | REEL CUTTER, 557-11 | 1 | 11 blades | |
| 21 - 12 | LM54GA-0114A3 | STAY, MOWER 603.4 (FRONT) | 1 | | |
| 21 - 13 | LM101--0153A0 | ROLLER ASSY, REAR | 1 | | |
| 21 - 14 | K0851535080 | OIL SEAL, PJN15358 | 2 | | |
| 21 - 15 | K0402035001 | RING, RETAINING R M35 | 2 | | |
| 21 - 16 | K0612062020 | BEARING, BALL SEAL 2RD 6202 | 2 | | |
| 21 - 17 | K6202000550 | HOUSING, ROLLER | 2 | | |
| 21 - 18 | K5051015280 | WASHER, C5191P 1-15-28 | 2 | | |
| 21 - 19 | LM101--0140Z2 | SHAFT, M10 | 2 | | |
| 21 - 20 | K0200050002 | WASHER, SPRING M5 | 2 | | |
| 21 - 21 | K0010050202 | BOLT, HT M5-20 | 2 | | |
| 21 - 22 | LM101--0137Z2 | SHAFT, ROLLER | 1 | | |
| 21 - 23 | LM150GA1365AD | ROLLER, REAR | 1 | | |
| 21 - 24 | K0830000020 | OIL SEAL, 254210 | 1 | | |
| 21 - 25 | K1440000010 | GREASE NIPPLE, STRAIGHT TYPE A | 1 | | |
| 21 - 26 | LM101--0123ZR | HOUSING, REEL (LH) | 1 | | |
| 21 - 27 | LM101--0103B0 | FRAME, (LH) | 1 | | |
| 21 - 28 | K0053080202 | BOLT, FLAT HEAD W/HEX. HOLE M8-20 | 3 | | |
| 21 - 29 | K0880050000 | O-RING, P50 | 1 | | |
| 21 - 30 | K0631302040 | BEARING, TAPER ROLLER JRP6 30204 | 1 | | |

21. Cutting section A (with Groomer)

LM101

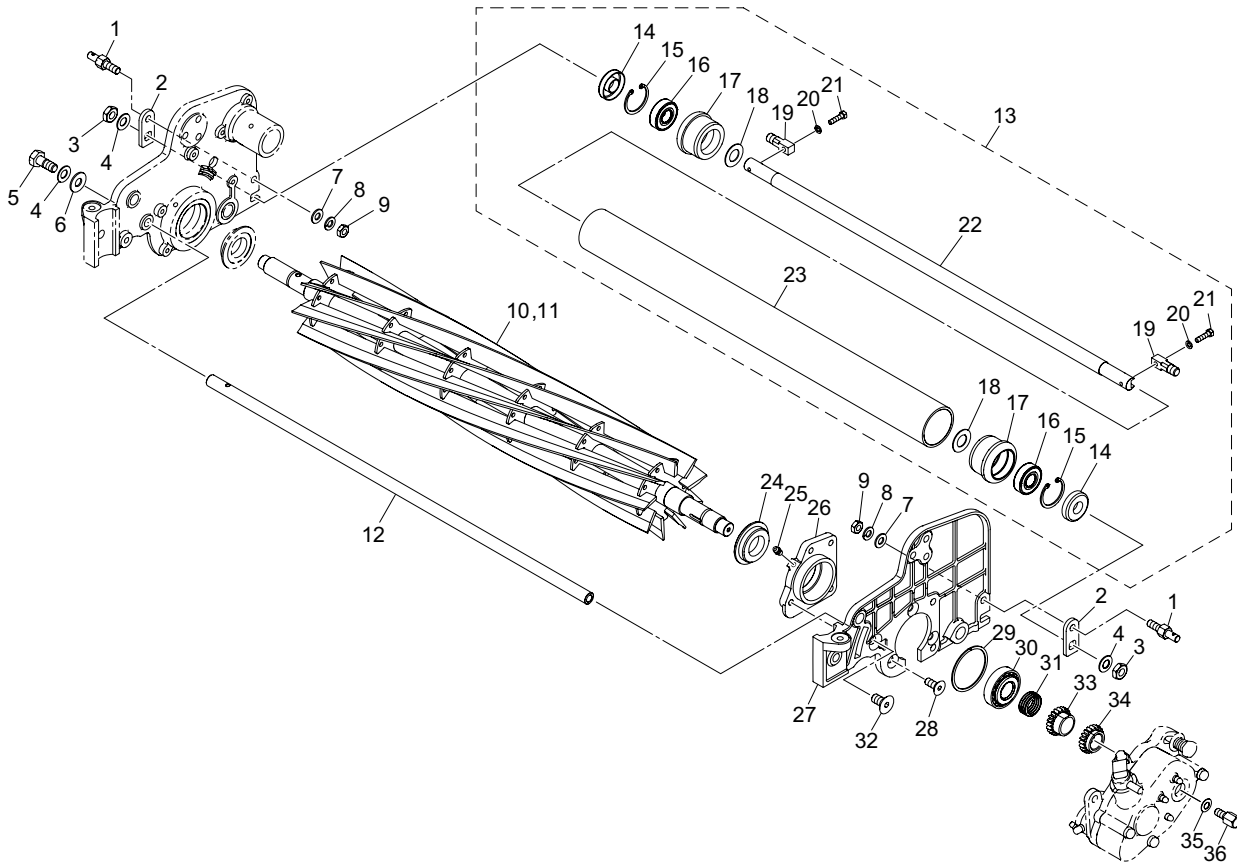

LM101_21_z00

| Cat No. | Code No. | Part name | Qty | Remark | SN of application |
|---------|---------------|-----------------------------------|-----|--------|-------------------|
| 21 - 31 | K1000000740 | SPRING, COMPRESSION M3.2-26.9-22 | 1 | | |
| 21 - 32 | K0053100202 | BOLT, FLAT HEAD W/HEX HOLE M10-20 | 1 | | |
| 21 - 33 | LM101--1205Z0 | GEAR, REEL 20-TEETH A | 1 | | |
| 21 - 34 | LM101--1206Z0 | GEAR, REEL 20-TEETH B | 1 | | |
| 21 - 35 | K0210080002 | SPRING, CONICAL DISC L M8 | 1 | | |
| 21 - 36 | LM101--0112Z2 | BOLT, RAPPING | 1 | | |
| | | | | | |
| | | | | | |
| | | | | | |
| | | | | | |
| | | | | | |

22. Cutting section B (with Groomer)

LM101

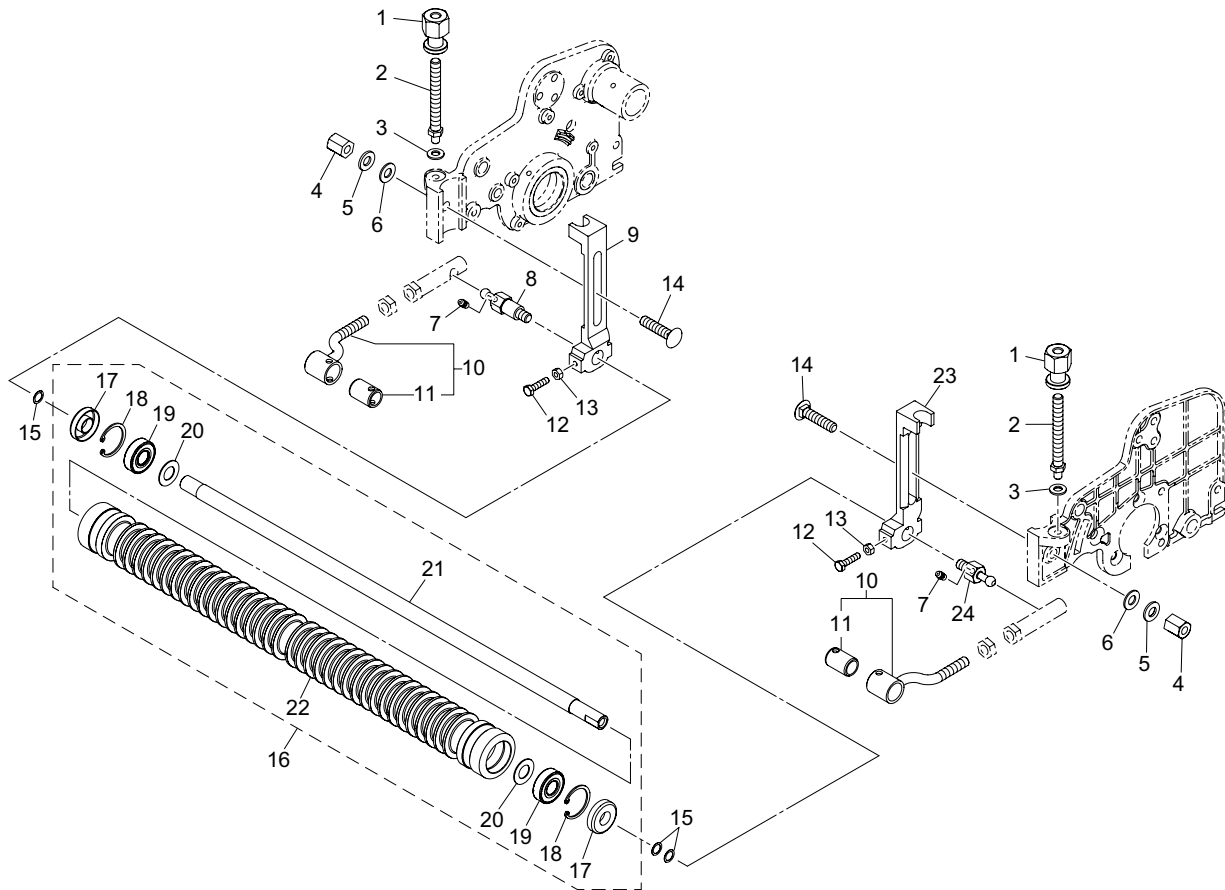

LM101_22_z00

| Cat No. | Code No. | Part name | Qty | Remark | SN of application |
|---------|---------------|--------------------------------|-----|----------------|-------------------|
| 22 - 1 | K6084000162 | ADJUSTER FOR ROLLER (IGCA) | 2 | | |
| 22 - 2 | LM101--0121Z0 | BOLT, SUS ADJ HOC | 2 | | |
| 22 - 3 | K0213080002 | WASHER, DISK SPRING 1H M8 | 2 | | |
| 22 - 4 | K0149107202 | NUT, HIGH M10-17-20 | 2 | | |
| 22 - 5 | K0213100002 | WASHER, DISK SPRING 1H M10 | 2 | | |
| 22 - 6 | K5000100002 | WASHER, M10 | 2 | | |
| 22 - 7 | K1440000010 | GREASE NIPPLE, STRAIGHT TYPE A | 2 | | |
| 22 - 8 | LM54G--0133Z0 | BOLT, SUS MOUNTING MOWER (RH) | 1 | | |
| 22 - 9 | LM101--1210Z2 | BRACKET, ROLLER (RH) | 1 | | |
| 22 - 10 | LM101--1213Z0 | FIXTURE COMP, MOWER | 2 | | |
| 22 - 11 | K6000000150 | BUSH, W/HOLE 15-20-29 | 2 | | |
| 22 - 12 | K0000060252 | BOLT, M6-25 | 2 | | |
| 22 - 13 | K0100060002 | NUT, M6 | 2 | | |
| 22 - 14 | K0025100452 | BOLT,CARRIAGE M10-45 | 2 | | |
| 22 - 15 | K5050310140 | WASHER, C5191P 0.3-10-14 | 0~6 | for adjustment | |
| 22 - 16 | LM101--0151Z0 | ROLLER ASSY, GROOVED | 1 | | |
| 22 - 17 | K0851535080 | OIL SEAL, PJN15358 | 2 | | |
| 22 - 18 | K0402035001 | RING, RETAINING R M35 | 2 | | |
| 22 - 19 | K0612062020 | BEARING, BALL SEAL 2RD 6202 | 2 | | |
| 22 - 20 | K5051015280 | WASHER, C5191P 1-15-28 | 2 | | |
| 22 - 21 | LM101--0118Z2 | SHAFT, ROLLER | 1 | | |
| 22 - 22 | LM101--0117Z3 | ROLLER, GROOVED | 1 | | |
| 22 - 23 | LM101--1209Z2 | BRACKET, ROLLER (LH) | 1 | | |
| 22 - 24 | LM54G--0132Z0 | BOLT, SUS MOUNTING MOWER (LH) | 1 | | |

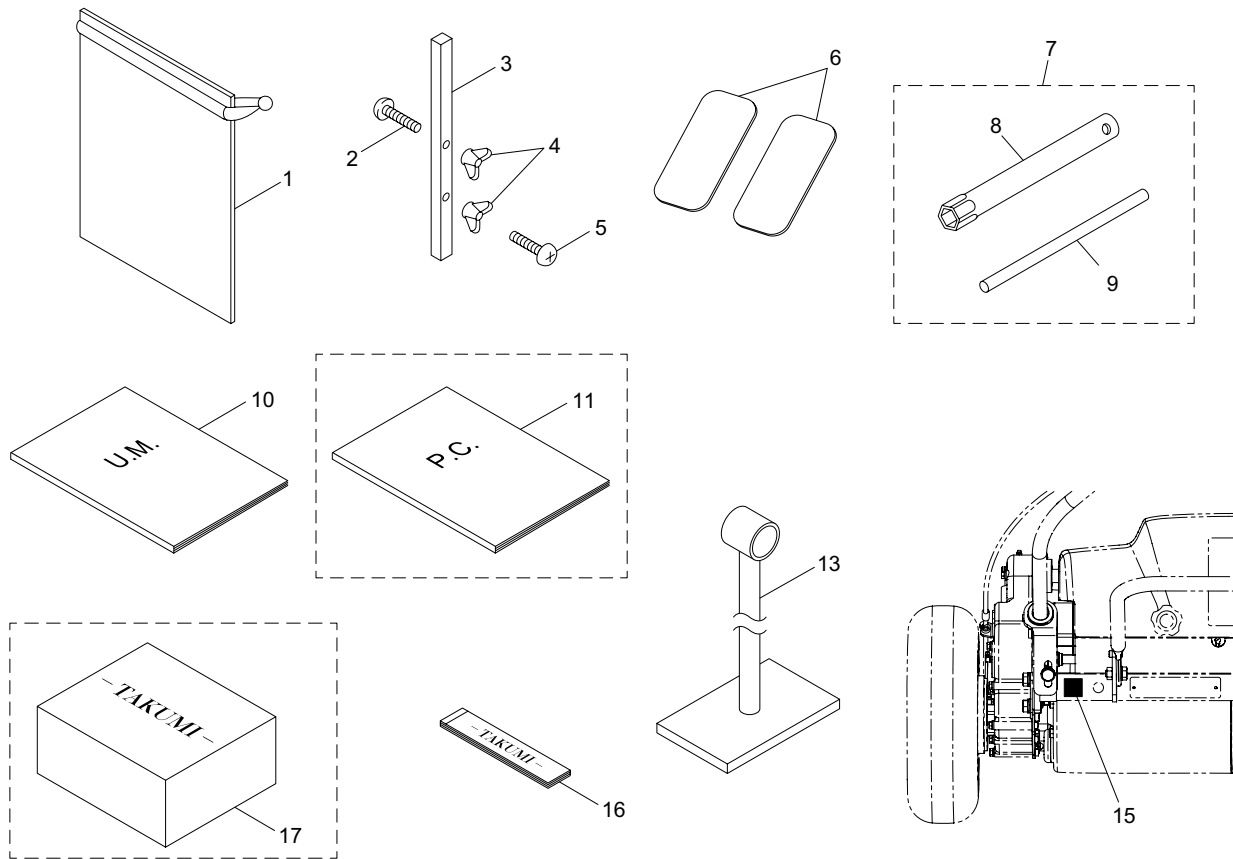

LM101_23_a04

| Cat No. | Code No. | Part name | Qty | Remark | SN of application |
|---------|-----------------|-------------------------|-----|--------------------|-------------------|
| 23 - 1 | K4801000050 | BAG, TOOL (BIG) | 1 | | |
| 23 - 2 | K0046060502 | SCREW, + PAN HEAD M6-50 | 1 | | |
| 23 - 3 | K6090000072 | GAUGE, CUTTING HEIGHT | 1 | | |
| 23 - 4 | K0141060002 | NUT, WING M6-3 | 2 | | |
| 23 - 5 | K0046060302 | SCREW, + PAN HEAD M6-30 | 1 | | |
| 23 - 6 | K4802000120 | GAUGE, THICKNESS0.5 | 2 | | |
| 23a- 7 | K2655GX120-10 | TOOL KIT, ENGINE GX120 | 1 | | |
| 23a- 8 | HN89216-Z0T-800 | WRENCH, SPARK PLUG | 1 | | |
| 23a- 9 | HN89219-805-000 | HANDLE, BOX WRENCH | 1 | | |
| 23a- 10 | LM101---UM--GBZ | O-MANUAL, LM101 GB-EN | 1 | | |
| 23a- 11 | LM101---PC--GBZ | P-CATALOG, LM101 GB-EN | 1 | Available for sale | |
| 23a- 12 | | | | | |
| 23 - 13 | LM54GB-0901ZD | STAND, FOR MAINTENANCE | 1 | | |
| 23 - 14 | | | | | |
| 23 - 15 | LM101--0901Z0 | DECAL, 2D CODE LM101 | 1 | | 10826- |
| 23 - 16 | K4802001050 | TAKUMI PAPER | 1 | | 10906- |
| 23 - 17 | K4802001060 | TAKUMI PAPER SET | 1 | Available for sale | |
| | | | | | |
| | | | | | |

24. Optional tools

LM101

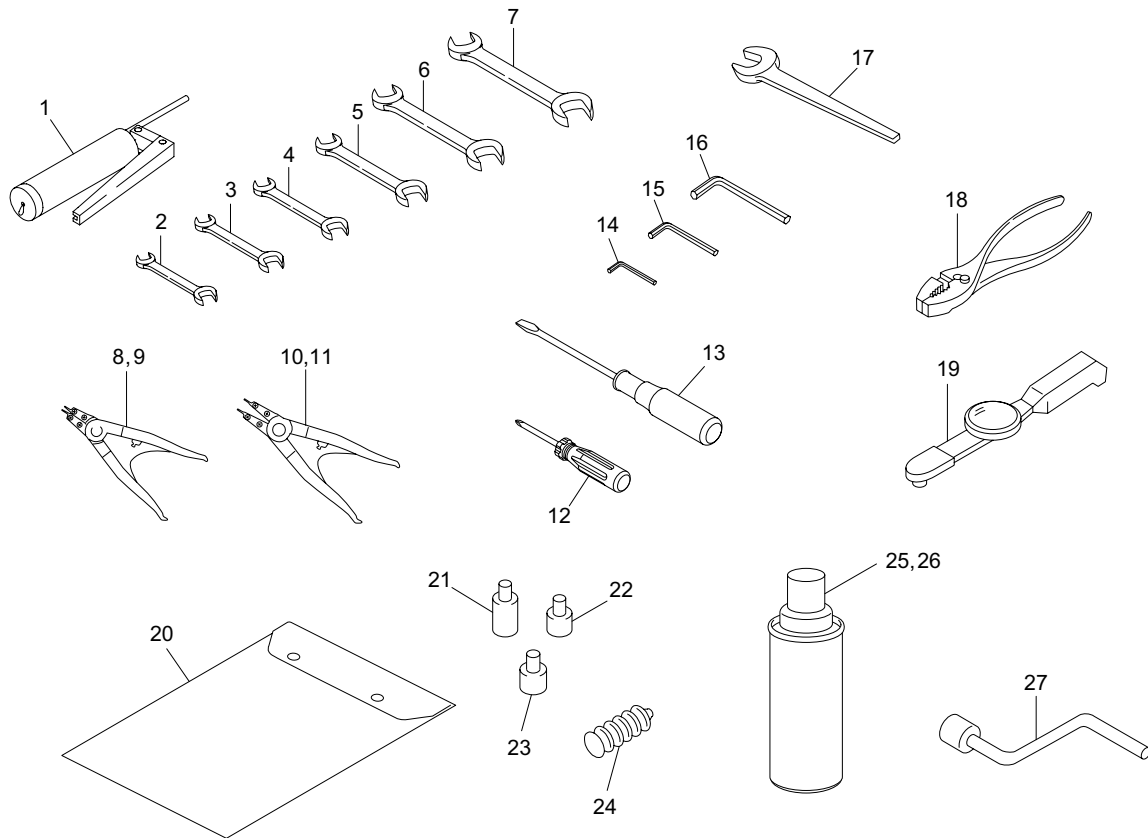

LM101_24_z01

| Cat No. | Code No. | Part name | Qty | Remark | SN of application |
|---------|-------------|---------------------------------|-----|--------|-------------------|
| 24 - 1 | K485000022 | GREASE, GUN | 1 | | |
| 24 - 2 | K4810070082 | WRENCH, 7*8 | 1 | | |
| 24 - 3 | K4810080102 | WRENCH, 8*10 | 1 | | |
| 24 - 4 | K4810100122 | WRENCH, 10*12 | 1 | | |
| 24 - 5 | K4810130172 | WRENCH, 13*17 | 1 | | |
| 24 - 6 | K4810190222 | WRENCH, 19*22 | 1 | | |
| 24 - 7 | K4810220242 | WRENCH, 22*24 | 1 | | |
| 24 - 8 | K4802000400 | TOOL, STOP RING PLIERS ST-1 | 1 | | |
| 24 - 9 | K4802000410 | TOOL, STOP RING PLIERS ST-2 | 1 | | |
| 24 - 10 | K4802000420 | TOOL, STOP RING PLIERS RT-2 | 1 | | |
| 24 - 11 | K4802000430 | TOOL, STOP RING PLIERS RT-2N | 1 | | |
| 24 - 12 | K4820000010 | SCREWDRIVER, +/- | 1 | | |
| 24 - 13 | K4820000020 | SCREWDRIVER, - 200 | 1 | | |
| 24 - 14 | K4813020001 | SPANNER, HEX PIN 2 | 1 | | |
| 24 - 15 | K4813040001 | SPANNER, HEX PIN 4 | 1 | | |
| 24 - 16 | K4813050001 | SPANNER, HEX PIN 5 | 1 | | |
| 24 - 17 | K4811240002 | WRENCH, SINGLE HEAD 24 | 1 | | |
| 24 - 18 | K4830000032 | PLIERS, 135 | 1 | | |
| 24 - 19 | K4802000370 | TOOL, TORQUE WRENCH 6-60 | 1 | | |
| 24 - 20 | K4801000050 | BAG, TOOL (BIG) | 1 | | |
| 24 - 21 | K4802000364 | TOOL, SOCKET ADAPTER 9.5*12.7 | 1 | | |
| 24 - 22 | K4802000354 | TOOL, SOCKET ADAPTER 6.35*9.5 | 1 | | |
| 24 - 23 | K4816006130 | SOCKET, HEX 6.35-13 | 1 | | |
| 24 - 24 | K2931000400 | GREASE, EXCELITE EP NO.2 (400G) | 1 | | |
| 24 - 25 | 750301 | SPRAY, LACQUER WINE RED | 1 | | |
| 24 - 26 | 750304 | SPRAY, LACQUER DARK GRAY | 1 | | |
| 24 - 27 | K4802000382 | TOOL, LAPPING HANDLE | 1 | | |

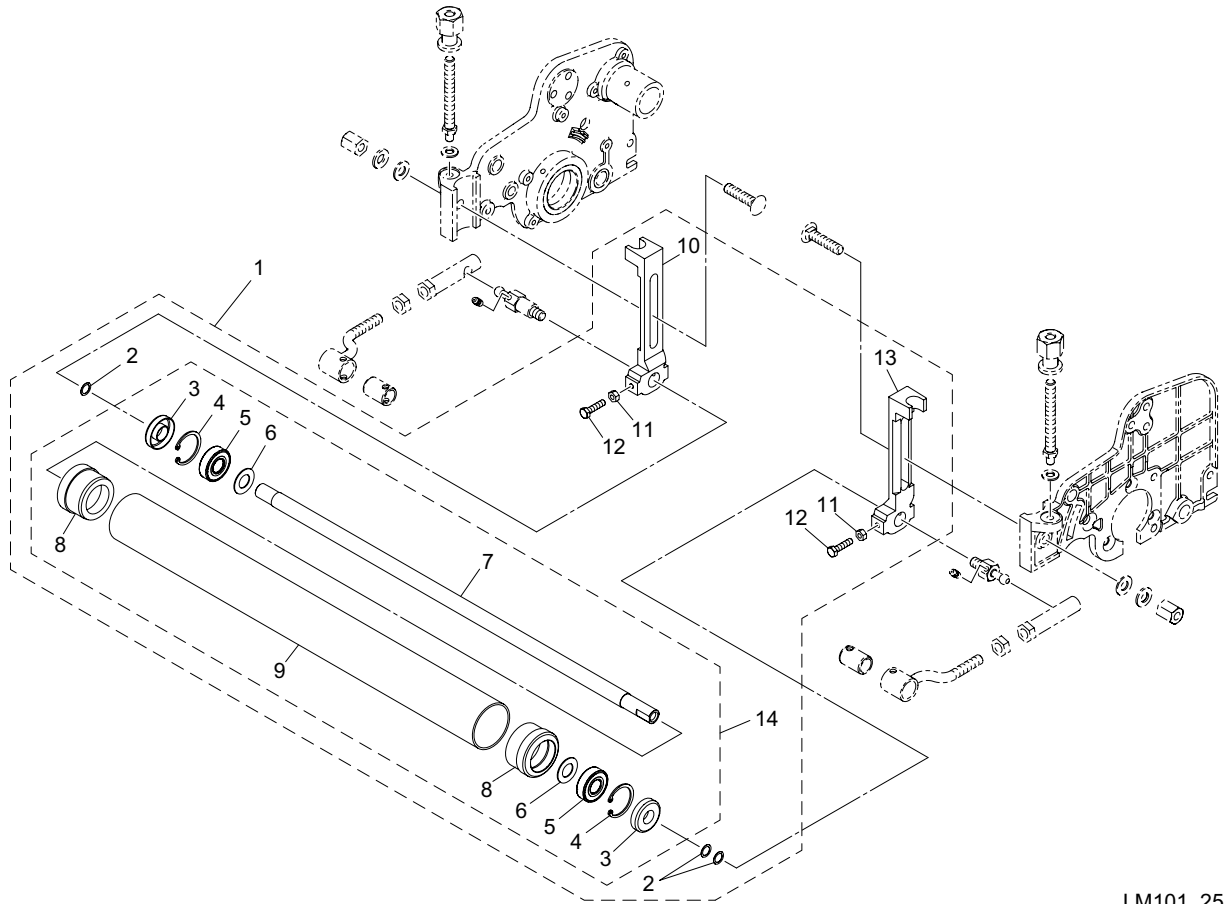

LM101_25_z00

| Cat No. | Code No. | Part name | Qty | Remark | SN of application |
|---------|---------------|-----------------------------|-----|----------------|-------------------|
| 25 - 1 | LM101--4301Z0 | ROLLER KIT, SMOOTH | 1 | option | |
| 25 - 2 | K5050310140 | WASHER, C5191P 0.3-10-14 | 0~6 | for adjustment | |
| 25 - 3 | K0851535080 | OIL SEAL, PJN15358 | 2 | | |
| 25 - 4 | K0402035001 | RING, RETAINING R M35 | 2 | | |
| 25 - 5 | K0612062020 | BEARING, BALL SEAL 2RD 6202 | 2 | | |
| 25 - 6 | K5051015280 | WASHER, C5191P 1-15-28 | 2 | | |
| 25 - 7 | LM101--0118Z2 | SHAFT, ROLLER | 1 | | |
| 25 - 8 | K6202000550 | HOUSING, ROLLER | 2 | | |
| 25 - 9 | LM101--4303ZD | PIPE , SMOOTH ROLLER | 1 | | |
| 25 - 10 | LM101--4305Z2 | BRACKET, ROLLER (RH) | 1 | | |
| 25 - 11 | K0100060002 | NUT, M6 | 2 | | |
| 25 - 12 | K0000060252 | BOLT, M6-25 | 2 | | |
| 25 - 13 | LM101--4304Z2 | BRACKET, ROLLER (LH) | 1 | | |
| 25 - 14 | LM101--4302Z0 | ROLLER ASSY, SMOOTH | 1 | | |
| | | | | | |
| | | | | | |
| | | | | | |
| | | | | | |

BARONESS[®]
Quality on Demand

 **KYOEISHA CO., LTD.**
Head Office 1-26, Miyuki-cho, Toyokawa-city, Tel :+81-533-84-1390
Aichi-pref, 442-8530 JAPAN Fax :+81-533-84-1220