

LM315GC

Riding Greens Mower (Diesel Model)

Owner's Operating Manual

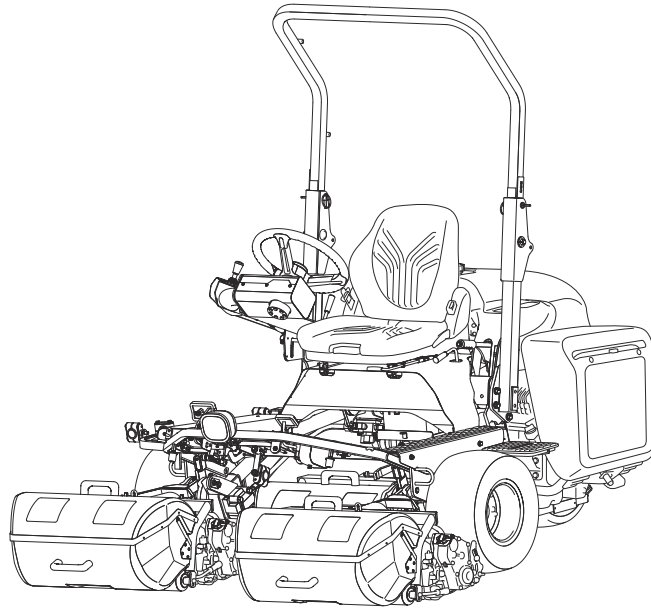

Serial No. LM315GC : 32166-

"Required reading"
Read this manual before using the machine.

BARONESS[®]
Quality on Demand

Original Instructions Ver.5.0

Regulations

California Proposition 65

(For California, USA)

WARNING:

Operating, servicing and maintaining a passenger vehicle or off-road vehicle can expose you to chemicals including engine exhaust, carbon monoxide, phthalates, and lead, which are known to the State of California to cause cancer and birth defects or other reproductive harm. To minimize exposure, avoid breathing exhaust, do not idle the engine except as necessary, service your vehicle in a well-ventilated area and wear gloves or wash your hands frequently when servicing your vehicle. For more information go to www.P65Warnings.ca.gov/passenger-vehicle.

318yi8-005

California Proposition 65_001

California Spark Arrester

(For California, USA)

Warning

Operation of this equipment may create sparks that can start fires around dry vegetation.
A spark arrester may be required.
The operator should contact local fire agencies for laws or regulations relating to fire prevention requirements.

It is a violation of California Public Resource Code Section 4442 or 4443 to use or operate the engine on any forest-covered, brush-covered, or grass-covered land unless the engine is equipped with a spark arrester, as defined in Section 4442, maintained in effective working order or the engine is constructed, equipped, and maintained for the prevention of fire pursuant to Section 4443.

The engine of this machine is not equipped with a spark arrester.

In some areas there are local, state, or federal regulations requiring that a spark arrester be used on the engine of this machine.

The recommended spark arrester for this machine is Part No.49025N Spark Arrester made by Nelson Global Products.

EU Regulations

(For EU)

This product complies with all relevant EU Regulations.

For more information, please refer to the Declaration of Conformity attached.

Thank you for purchasing the Baroness product. This manual describes the proper handling, adjustment, and inspection of your product. We hope you will use the product safely, and take advantage of its best performance.

Keeping The Owner's Operating Manual

Keep this manual in the box on the right side of the seat.

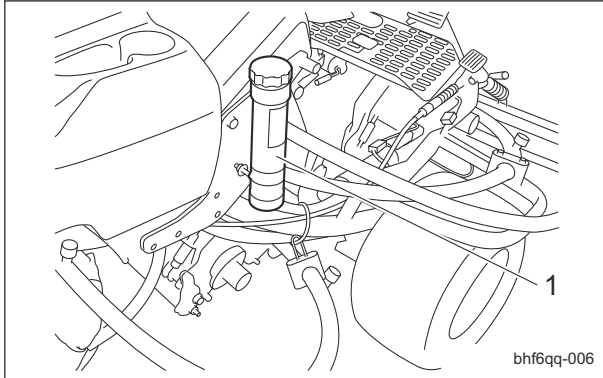

Keeping The Owner's Operating Manual_001

1	Box
---	-----

QR Code

(*QR Code is a registered trademark of DENSO WAVE INCORPORATED.)

A QR code label is affixed on the machine.

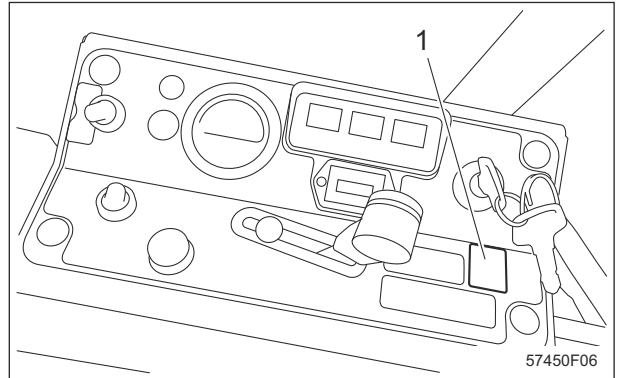

QR Code_001

1	QR code label
---	---------------

Scan the QR code with your smartphone for easy access to Baroness Manual Reference Service where you can browse Owner's Operating Manual and Parts Catalog.
<https://doc.baroness-international.com/manuals/LM315GC>



QR Code_002

Introduction

Read this manual carefully to ensure that you thoroughly understand how to properly operate and maintain the product, and to avoid causing injury to yourself or others.

The operator is responsible for operating the product properly and safely.

Maintenance service for this machine should be performed by a mechanic with expertise.

If you have any questions concerning maintenance or genuine parts, please contact a Baroness dealer or Kyoisha.

When making inquiries about your product, please specify the model and serial number.

When loaning or transferring the product, please also provide this manual together with the product.

Kyoisha Co., Ltd.

Warning Symbols

This manual uses the following warning symbols for handling precautions that are important for your safety.



696cq5-001

Warning symbol

This symbol indicates the articles regarding "Danger," "Warning," or "Caution."

Those articles describe important safety precautions and so read them carefully to understand completely before operating the machine.

Failure to adequately follow these safety precautions may cause an accident.

Danger

This symbol indicates that serious injury or death will occur if the warning is ignored.

Warning

This symbol indicates that serious injury or death may occur if the warning is ignored.

Caution

This symbol indicates that injury or damage to property may occur if the warning is ignored.

Important

This symbol indicates precautions on the mechanism of the machine.

Precautionary Statement

 Caution

The information described in this manual is subject to change for improvement without prior notice.

When replacing parts, be sure to use genuine Baroness parts or parts designated by Kyo-eisha.

Note that the Baroness product warranty may not apply to defects caused by the use of parts from other companies.

Prior to use, carefully read the following manuals to thoroughly understand the contents for safe and correct operation.

- Baroness Owner's Operating Manual
- The Engine's Owner's Manual
- The Battery's Owner's Manual

Purpose

For greens/for tees: This product is intended for cutting turf grass at golf courses.

For fields: This product is intended for cutting turf grass on soccer and baseball fields.

Do not use this product in any other way than its intended purpose, and do not modify this product.

Operating this product for other purposes and modifying it may be very dangerous and may cause damage to the product.

In addition, this product is not authorized for operation as a special motor vehicle. Do not operate it on public roads.

LM315GC

Introduction

Safety	Page 1-1	Maintenance	Page 6-1
Safe Operating Practices	Page 1-2	Precautions for Maintenance	Page 6-2
Disposal	Page 2-1	Operations before Maintenance	Page 6-2
Recycle and Waste Disposal	Page 2-2	Jacking Up The Machine	Page 6-3
Product Overview	Page 3-1	Inspection and Cleaning	Page 6-4
Specifications	Page 3-2	Supplying Fluids	Page 6-7
Names of Each Section	Page 3-5	Greasing	Page 6-12
Regulation Decals	Page 3-8	Lubrication	Page 6-17
Safety Signs and Instruction Signs	Page 3-13	Adjustment	Page 6-18
Operation Decals	Page 3-18	Replacement	Page 6-36
Description of Functions	Page 4-1	Storage	Page 6-48
Light Switch	Page 4-2	Repair	Page 7-1
Throttle Lever	Page 4-2	Precautions for Repair	Page 7-2
Key Switch	Page 4-2	Inspection	Page 7-2
Mower Pedal	Page 4-3	Adjustment	Page 7-3
Joystick	Page 4-3	Replacement	Page 7-4
Mower Unit Up Switch	Page 4-4	Towing	Page 7-9
2WD/3WD Selector Switch	Page 4-5	Appended Table	Page 8-1
Reel Rotation Switch	Page 4-5	Tightening Torques	Page 8-2
Reel Reverse Lever	Page 4-6	Daily Check List	Page 8-7
Transmission Selector Lever	Page 4-6	Maintenance Schedule	Page 8-9
Traveling Pedal	Page 4-7	List of Adjusted Values	Page 8-14
Parking Brake Lever	Page 4-7	Records	Page 9-1
Broom Holder	Page 4-8	Daily Check Records	Page 9-2
Swisher Holder	Page 4-8	Maintenance Records	Page 9-5
Instruments on The Operation Panel	Page 4-8		
Fuel Gauge	Page 4-10		
Safety Device	Page 4-10		
Warning Mechanisms	Page 4-10		
Handling Instructions	Page 5-1		
Operations before Service	Page 5-2		
Inspection before Use	Page 5-3		
Adjustment before Work	Page 5-11		
Mounting and Dismounting	Page 5-13		
Start/Stop of Engine	Page 5-13		
Parking and Stopping	Page 5-15		
Move	Page 5-15		
Cutting Work	Page 5-16		
Transporting	Page 5-18		
Cleaning after Use	Page 5-18		
Storage	Page 5-19		

LM315GC

Contents

Safe Operating Practices Page 1-2

Training Page 1-2

Preparation Page 1-2

Operation Page 1-3

Maintenance Page 1-4

Storage Page 1-5



Safety

Failure to adequately follow these safety precautions may cause an accident resulting in injury or death.

Danger

This product is designed to ensure safe operation and has been tested and inspected thoroughly before shipment from the factory. The product is equipped with safety devices to prevent accidents.

However, whether the product demonstrates its original performance level depends on the manner in which it is operated and handled, as well as the manner in which it is managed on a daily basis.

Inappropriate use or management of the product may result in injury or death.

Observe the following safety instructions to ensure safe operation.

Safe Operating Practices

Training

1. Read this manual and other training material carefully.

Be familiar with the controls, safety signs, and the proper use of the equipment.

2. If the operator or mechanic can not read the language used in this manual, it is the owner's responsibility to explain this material to them.

3. All operators and mechanics should seek and obtain professional and practical instruction.

The owner is responsible for training the users.

Such instruction should emphasize:

- [1] The need for care and concentration when working with ride-on machines.

- [2] Control of a ride-on machine sliding on a slope will not be regained by the application of the brake.

The main reasons for loss of control are

- Insufficient wheel grip
- Being driven too fast
- Inadequate braking
- The type of machine is unsuitable for its task
- Lack of awareness of the effect of ground conditions, especially slopes
- Incorrect hitching and load distribution

4. Never allow children or people unfamiliar with these instructions to use or service the machine.
Local regulations may restrict the age of the operator.
5. The owner/user can prevent and is responsible for accidents or injuries occurring to themselves, other people, or property.
6. Keep in mind that the owner, operator, and mechanic are responsible for accidents or hazards occurring to other people or their property.
7. The ROPS is an integral and effective safety device.
Do not remove or alter the ROPS.
8. Replace a damaged ROPS.
Do not repair or alter.
9. You can find additional safety information where needed throughout this manual.
10. Determine the left and right sides of the machine from the normal operating position.

Preparation

1. Evaluate the terrain to determine what accessories and attachments are needed to properly and safely perform the job.
Only use accessories and attachments approved by the manufacturer.
2. While operating, always wear substantial footwear, long trousers, hard hat, safety glasses, mask, and ear protection.
Long hair, loose clothing, or jewelry may get tangled in moving parts.
Do not operate the equipment when barefoot or wearing open sandals.
3. Inspect the area where the equipment is to be used and remove all objects such as rocks, toys and wire which can be thrown by the machine.
4. Keep children out of the operating area and under the watchful care of a responsible adult other than the operator.
5. Exercise care in the handling of fuel.

Warning

Fuel is highly flammable.
Take the following precautions:

- [1] Store fuel in containers specifically designed for this purpose.

- [2] Add fuel before starting the engine.
Never remove the cap of the fuel tank or add fuel while the engine is running or when the engine is hot.
- [3] Refuel outdoors only and do not smoke while refueling.
- [4] If fuel is spilled, do not attempt to start the engine but move the machine away from the area of spillage and avoid creating any source of ignition until petrol vapours have dissipated;
- [5] Replace all fuel tanks and container caps securely.
6. Check that operator's presence controls, safety switches and shields are attached and functioning properly.
Do not operate unless they are functioning properly.
7. If the brake operation is faulty, be sure to adjust or repair them before operating the machine.
8. Replace faulty mufflers.
9. On multi-cylinder/multi-reel machines, take care as rotating one cylinder/reel can cause other cylinders/reels to rotate.
8. Never operate while people, especially children, or pets are nearby.
9. Only operate in good light, keeping away from holes and hidden hazards.
10. Do not operate the machine when there is the risk of lightning.
11. Do not stop or start suddenly.
12. Look behind and down before backing up to be sure of a clear path.
13. Slow down and use caution when making turns and crossing roads and sidewalks.
14. Use care when approaching blind corners, shrubs, trees, or other objects that may obscure vision.
15. Do not take your eyes off the road ahead.
Do not operate the machine with no hands.
16. Keep a folding ROPS in the raised and locked position and use the seat belt when operating the machine.
17. Lower a folding ROPS temporarily only when absolutely necessary.
Do not wear the seat belt when folded down.
There is no rollover protection when a folding ROPS is in the down position.

Operation

1. Do not operate the machine under the influence of alcohol or drugs.
2. Do not operate the engine in a confined space where dangerous carbon monoxide fumes can collect.
3. Be sure all drives and shift are in neutral and parking brake is engaged before starting engine.
Only start engine from the operator's position.
Use seat belts if provided.
4. Do not change the engine governor settings or overspeed the engine.
Operating the engine at excessive speed may increase the hazard of personal injury.
5. Never operate the machine with damaged guards, shields, or without safety protective devices in place.
Be sure all interlocks are attached, adjusted properly, and functioning properly.
6. Keep hands and feet away from the rotating parts.
7. Do not carry passengers.
18. Remember there is no such thing as a safe slope.
Travel on grass slopes requires particular care.
To guard against overturning, follow these instructions.
 - [1] Do not stop or start suddenly when going up or downhill.
 - [2] Engage clutch slowly, always keep machine in gear, especially when traveling downhill.
 - [3] Machine speeds should be kept low on slopes and during turns.
 - [4] Stay alert for humps and hollows and other hidden hazards.
19. Never use the machine on a slope with an angle of gradient that is greater than that specified or in a place where there is a danger of the machine slipping.
20. Use extra care while operating machine with a grass catcher or other attachments.
They can affect the stability of the machine.
21. Disengage drive to the cutting unit(s), when other than operating.

Safety

22. Do the following before leaving the operator's position.
 - [1] Stop on level ground.
 - [2] Disengage the all drives.
 - [3] Set the parking brake.
 - [4] Stop the engine.
 - [5] Remove the ignition key.
23. Stop the engine in the following conditions.
 - [1] Before refuelling.
 - [2] Before removing the grass catcher.
 - [3] Before making height or depth adjustment unless adjustment can be made from the operator's position.
 - [4] Before clearing blockages.
 - [5] Before checking, cleaning or working on the machine.
 - [6] After striking a foreign object or if an abnormal vibration occurs.
Inspect the machine for damage and make repairs before restarting and operating the equipment.
24. Reduce the throttle setting during engine run-out.
25. Do not direct discharge material toward anyone.
Avoid discharging material against a wall or obstruction.
Material may ricochet back toward the operator.
26. Take care when loading or unloading the machine into a trailer or a truck.
Load or unload the machine in a flat and safe place.
Before loading or unloading, set the parking brake on the truck or trailer, stop the engine, and chock the wheels.
When transporting the machine on a truck or a trailer, set the parking brake, stop the engine, and fasten the machine to the truck with a rope or other suitable restraining device that has sufficient strength.
When using a running board, select one with sufficient strength, length, and width and that will not cause the machine to slip.
27. Close the fuel valve before transporting the machine.
2. Implement the following work before adjusting, cleaning or repairing.
 - [1] Stop the machine on level ground.
 - [2] Disengage drive to the cutting unit(s).
 - [3] Lower the cutting unit(s) and/or attachment(s).
 - [4] Set the parking brake.
 - [5] Stop the engine.
 - [6] Remove the ignition key.
 - [7] Wait for all movement to stop.
3. Allow the engine/muffler to cool before checking/maintenance.
4. To reduce the fire hazard, keep hot parts such as the engine and silencer/muffler, battery compartment and fuel storage area free of grass, leaves, or excessive grease. Clean up oil or fuel spillage.
5. Appropriately manage and correctly use the tools necessary for servicing or adjusting the machine.
6. Disconnect battery before making any repairs.
Disconnect the negative terminal first and the positive last.
Reconnect positive first and negative last.
7. Use jack stands to support components when required.
8. Keep hands and feet away from moving parts.
If possible, do not make adjustments with the engine running.
9. Make sure that parts such as wires are not touching each other and that their covers have not come off.
10. Keep all parts in good working condition and all hardware tightened.
Replace all worn or damaged decals.
11. Keep all nuts, bolts and screws tight to be sure the equipment is in safe working condition.
12. Carefully release pressure from components with stored energy.
13. Be sure to depressurize the hydraulic system before performing maintenance operations on it such as removing hydraulic equipment.
14. Check whether line connectors in the hydraulic system are properly tightened.
Before applying hydraulic pressure, check the connections of the hydraulic pressure lines and the condition of the hoses.

Maintenance

1. Never allow untrained personnel to service machine.

15. When checking the hydraulic circuit for pinhole leaks or oil leakage from nozzles, do not use your hands.
Use items such as paper or corrugated cardboard to find leakage points.
Be extremely careful with high-pressure oil as it may pierce your skin, resulting in an injury.
If fluid is injected into the skin it must be surgically removed within a few hours by a doctor familiar with this form of injury or gangrene may result.
 16. Use care when checking the cylinders/reels and bed knives.
Wear gloves and use caution when servicing them.
 17. Be careful during adjustment of the machine to prevent entrapment of the fingers between moving blades and fixed parts of the machine.
 18. On multi-cylinder/multi-reel machines, take care as rotating one cylinder/reel can cause other cylinders/reels to rotate.
 19. Check the grass catcher frequently for wear or deterioration.
 20. Charge batteries in an open well ventilated area, away from spark and flames.
Unplug charger before connecting or disconnecting from battery.
Wear protective clothing and use insulated tools.
 21. If the fuel tank has to be drained, do this outdoors.
7. Swallowing engine coolant can cause injury or death; keep out of reach from children and pets.

Storage

1. When machine is to be parked, stored, or left unattended, lower the cutting unit(s) and/or attachment(s) unless a positive mechanical lock is provided.
2. Allow the engine to cool before storing in any enclosure.
3. Only cover the machine with a sheet after hot parts have sufficiently cooled down.
4. Never store the equipment with fuel in the tank inside a building where fumes may reach an open flame or spark.
5. If the engine is provided with a shut-off valve, shut off valve while storing or transporting.
6. Do not store fuel near flames.

Recycle and Waste Disposal Page 2-2

About RecyclePage 2-2

About Waste Disposal Page 2-2

Disposal

Recycle and Waste Disposal

About Recycle

Recycling battery etc. is recommended for environmental conservation and economical use of resources.

It may be required by local laws.

About Waste Disposal

Make sure that waste generated when servicing or repairing the machine is disposed of in accordance with local regulations. (e.g. waste oil, antifreeze, rubber products, and wires etc.)

Specifications Page 3-2

SpecificationsPage 3-2

Sound Pressure Level Page 3-4

Sound Power Level Page 3-4

Vibration LevelPage 3-4

Carbon Dioxide (CO₂) EmissionsPage 3-4**Names of Each Section Page 3-5****Regulation DecalsPage 3-8**

Positions of Regulation Decals Page 3-8

Description of Regulation Decals Page 3-8

Safety Signs and Instruction Signs ... Page 3-13About Safety Signs and Instruction
SignsPage 3-13Positions of Safety Decals and
Instruction Decals Page 3-13Description of Safety Decals and
Instruction Decals Page 3-13**Operation Decals Page 3-18**

Positions of Operation Decals Page 3-18

Description of Operation Decals Page 3-18

Product Overview

Specifications

Specifications

Model		LM315GC					
Name		Riding Greens Mower					
Type		for greens		for tees		for fields	
Dimensions	Total length		239 cm	94.09 in	←	←	←
	Total width		172 cm	67.72 in	←	←	←
	Total height	Steering wheel	132 - 141 cm	51.97 - 55.51 in	←	←	←
Weight	Machine: 2WD (empty fuel tank)	without ROPS, Grass catcher, Groomer	659 kg	1452.82 lb	←	←	←
	Machine: 3WD (empty fuel tank)	without ROPS, Grass catcher, Groomer	684 kg	1507.94 lb	←	←	←
	Grass catchers (for one machine)		12 kg	26.46 lb	←	←	←
	Groomers (for one machine)		10 kg	22.05 lb	←	←	←
	ROPS + Seatbelt		28 kg	61.73 lb	←	←	←
Minimum turning radius		161 cm	63.39 in	←	←	←	
Engine	Model		Kubota D722-E4B		←	←	
	Type		Vertical water-cooled 4-cycle diesel engine		←	←	
	Total displacement		719 cm ³ (0.719 L)	43.87 cu.in.	←	←	←
	Maximum output		-		-		-
	Rated output		12.4 kW (16.9 PS)/ 3,000 rpm		←	←	
Fuel tank capacity		Diesel 20.0 dm ³ (20.0 L)	Diesel 5.28 U.S.gals	←	←	←	
Fuel consumption		286 g/kW · h (rated output)	210 g/PS · h (rated output)	←	←	←	
Engine oil capacity		2.8 dm ³ (2.8 L)	0.74 U.S.gals	←	←	←	
Coolant volume		3.0 dm ³ (3.0 L)	0.79 U.S.gals	←	←	←	
Hydraulic tank capacity		16.0 dm ³ (16.0 L)	4.23 U.S.gals	←	←	←	
Transmission oil capacity		-		-		-	
Operating width (Mowing width)		152 cm	59.84 in	←	←	←	

Product Overview

Operating height (Mowing height)		1.5 - 18.0 mm	0.059 - 0.709 in	6.0 - 20.0 mm	0.236 - 0.787 in	10.0 - 40.0 mm	0.394 - 1.575 in
Number of Blades		9, 11		7		←	
Drive	Traveling	HST 2WD [3WD (2WD/3WD selectable)]		←		←	
	Mowing	Mechanical		←		←	
Speed (HST)	Forward	0 - 15.0 km/h	0 - 9.32 mph	←	←	←	←
	Reverse	0 - 6.0 km/h [2WD selection of 3WD model: 0 - 9.0 km/h]	0 - 3.73 mph [2WD selection of 3WD model: 0 - 5.59 mph]	←	←	←	←
Speed (Mechanical)		-		-		-	
Efficiency		7,296 m ² /h (6.0 km/h x mowing width x 0.8)	1.8 acres/ hour (3.73 mph x mowing width x 0.8)	←	←	←	←
Maximum inclination for operation		15 degrees		←		←	
Tire size	Front wheel	Smooth 18 x 9.50-8 2P		Pillow Dia 18 x 8.50-8 4P		Smooth 18 x 9.50-8 2P	
	Rear wheel	Smooth 18 x 9.50-8 2P		Pillow Dia 18 x 8.50-8 4P		Smooth 18 x 9.50-8 2P	
Tire pneumatic pressure	Front wheel	80 kPa (0.8 kgf/cm ²)	12 psi	100 kPa (1.0 kgf/ cm ²)	15 psi	80 kPa (0.8 kgf/cm ²)	12 psi
	Rear wheel	80 kPa (0.8 kgf/cm ²)	12 psi	100 kPa (1.0 kgf/ cm ²)	15 psi	80 kPa (0.8 kgf/cm ²)	12 psi
Battery		55B24L (BCI GROUP SIZE 51R: Recommended equivalent product EXIDE 51R-60)		←		←	
Engine plug		-		-		-	

The factory default maximum engine rpm is 3,000 rpm.

Product Overview

Sound Pressure Level

Sound Pressure Level

This machine was confirmed to have a continuous A-weighted sound pressure level of 88 dB by measuring identical machines in accordance with the procedure specified in ISO5395-1:2013.

Sound Power Level

Sound Power Level

This machine was confirmed to have a sound power level of 103 dB by measuring identical machines in accordance with the procedure specified in ISO 5395-1:2013.

Vibration Level

Hand-Arm Vibration

This machine was confirmed not to exceed a vibration level of 2.5 m/s² to hands and arms by measuring identical machines in accordance with the procedure specified in ISO 5395-1:2013.

Whole Body Vibration

This machine was confirmed not to exceed a vibration level of 0.5 m/s² to the whole body by measuring identical machines in accordance with the procedure specified in ISO 5395-1:2013.

Carbon Dioxide (CO₂) Emissions

For the CO₂ value on the engine of this machine, refer to the engine's owner's manual.

Product Overview

Names of Each Section

Overall view A

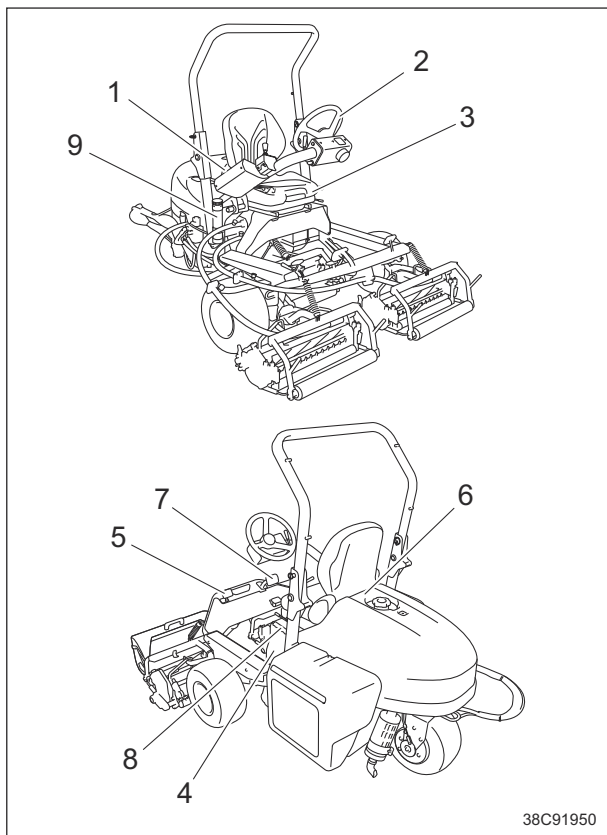

Names of Each Section_001

1	Operation panel
2	Steering wheel
3	Seat
4	Underseat cover
5	Mower pedal (Mower pedal model)
6	Transmission selector lever
7	Traveling pedal
8	Parking brake lever
9	Box

Overall view B

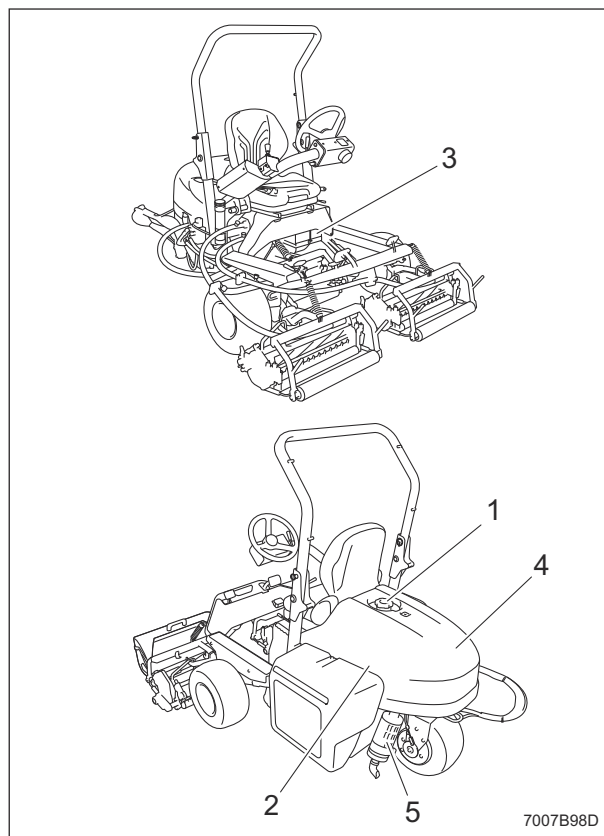

Names of Each Section_002

1	Fuel tank
2	Fuel filter
3	Battery
4	Hood
5	Muffler

Product Overview

Product Overview

Overall view C

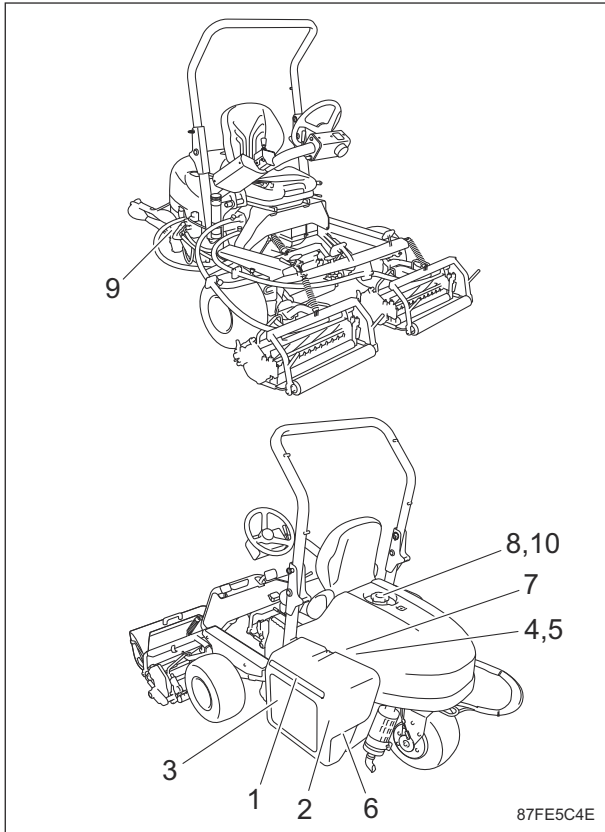

Names of Each Section_003

1	Radiator
2	Radiator cover
3	Dustproof mesh
4	Engine
5	Engine oil filter
6	Reserve tank
7	Air cleaner
8	Hydraulic tank
9	Hydraulic oil line filter
10	Hydraulic oil suction filter

Overall view D

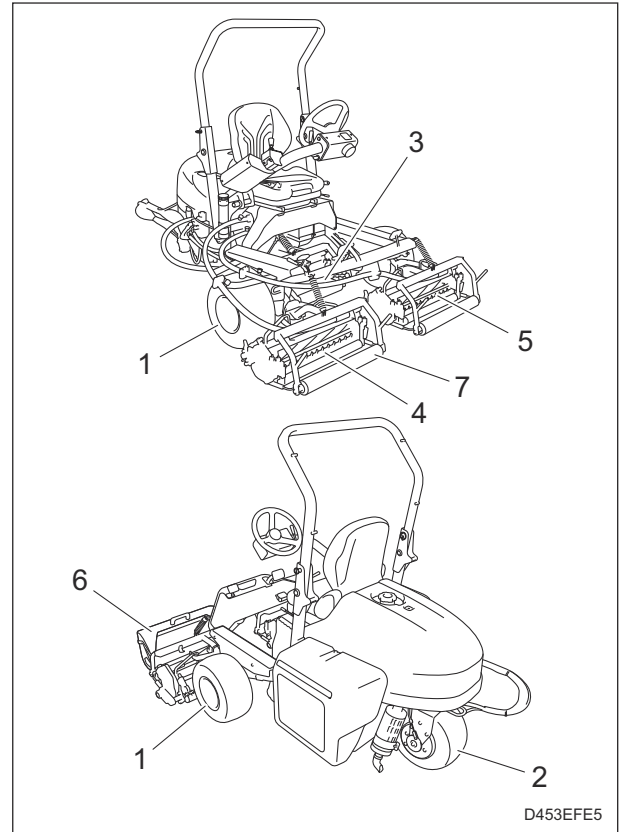

Names of Each Section_004

1	Front tire
2	Rear tire
3	Mower unit #1
4	Mower unit #2
5	Mower unit #3
6	Grass catcher
7	Grass catcher roller

Product Overview

Operation panel

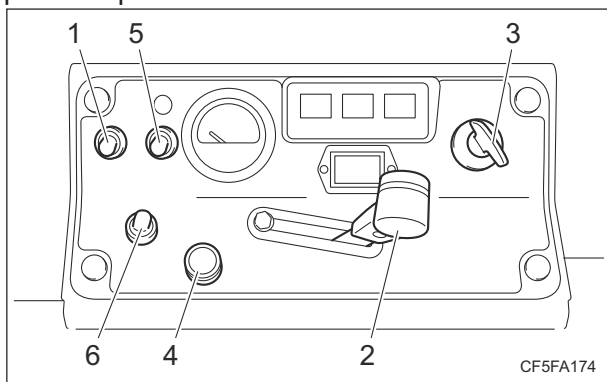

CF5FA174

Names of Each Section_005

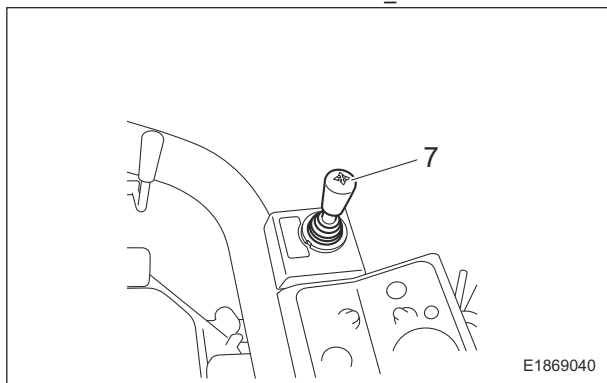

E1869040

Names of Each Section_006

1	Light switch
2	Throttle lever
3	Key switch
4	Mower unit up switch
5	2WD/3WD selector switch
6	Reel rotation switch
7	Joystick (Joystick model)

Mower unit

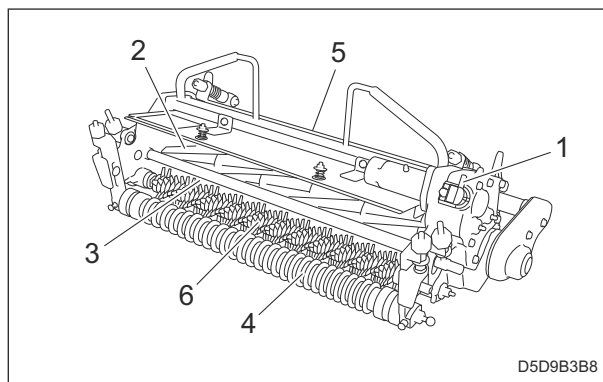

D5D9B3B8

Names of Each Section_007

1	Reel reverse lever
2	Reel cutter
3	Bed knife
4	Front roller
5	Rear roller
6	Groomer

Product Overview

Regulation Decals

Positions of Regulation Decals

Main vehicle

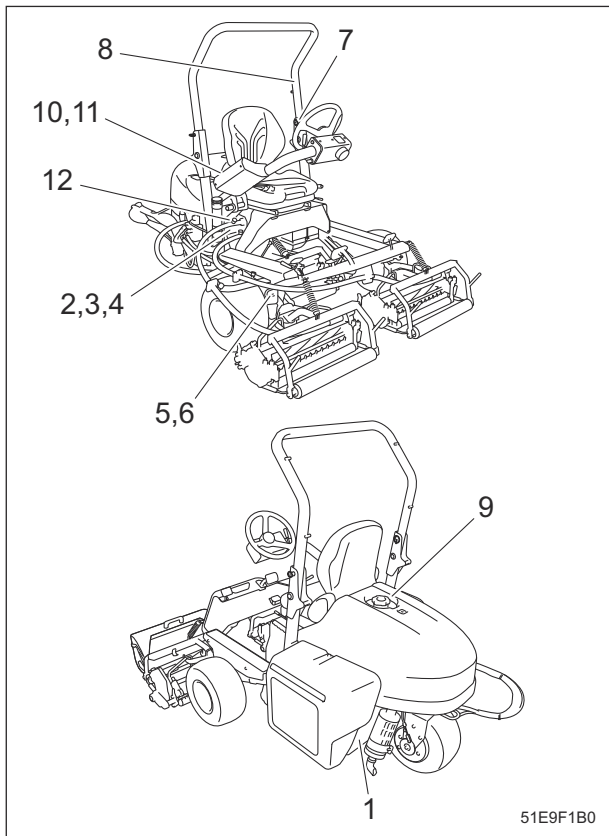

Positions of Regulation Decals_001

1	Serial number plate
2	Specification decal
3	CE Mark
4	UKCA mark (#31648 - 32041)
5	Noise emission decal
6	Year of manufacture decal
7	ROPS compliance decal
8	ROPS caution decal
9	Indicating diesel fuel decal
10	California proposition 65 decal (riding type)
11	Spark arrester warning decal
12	ISED compliance decal (#32341-)

Battery

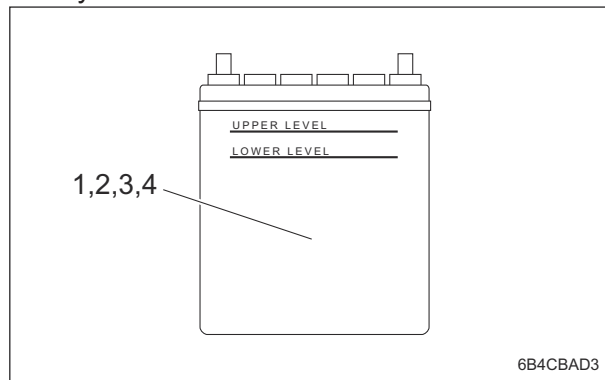

Positions of Regulation Decals_002

1	Battery capacity decal
2	EU battery regulation decal
3	Recycle decal
4	Battery danger decal

Description of Regulation Decals

Serial Number Plate

The serial number plate indicates the model and serial number of the machine.

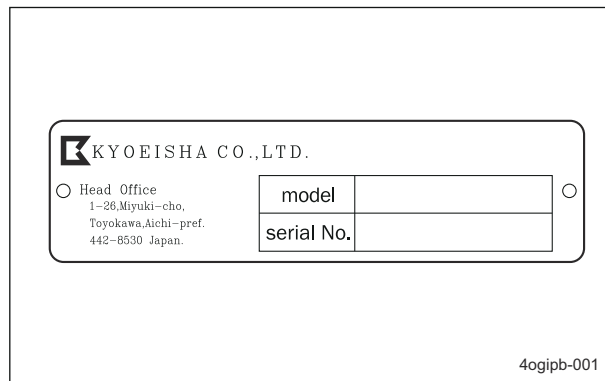

Serial Number Plate_001

Specification Decal

(For EU)

The Specification decal indicates the model and weight, etc.

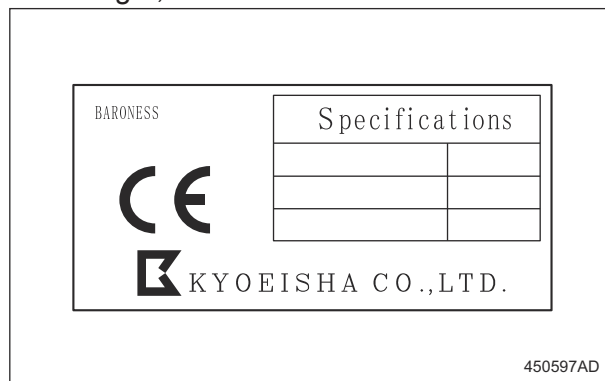

Specification Decal_001

CE Mark

(For EU)
CE mark indicates that the machine sold in the EU nations complies with the EU requirements.

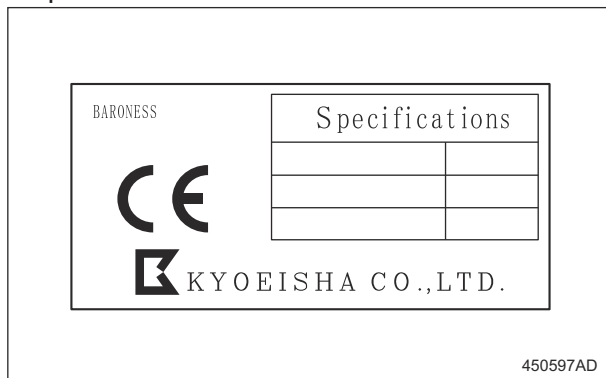

CE Mark_001

Noise Emission Decal

(For EU)
The noise emission decal indicates the sound power level determined by measuring identical machines in accordance with the procedure specified in the regulations of EU.

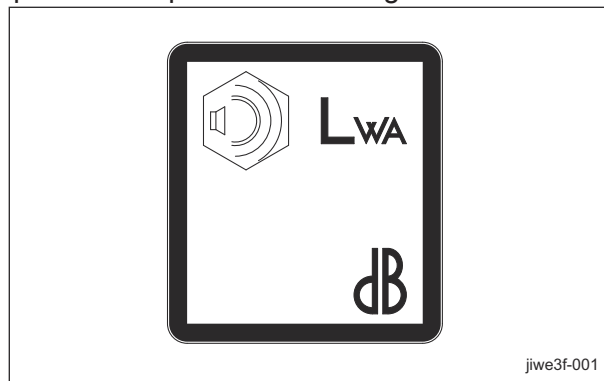

Noise Emission Decal_001

UKCA Mark

(For UK)
UKCA mark indicates that the machine sold in the UK complies with the UK requirements.



UKCA Mark_001

Year of Manufacture Decal

(For EU)
The year of manufacture decal indicates the year when this machine was manufactured.

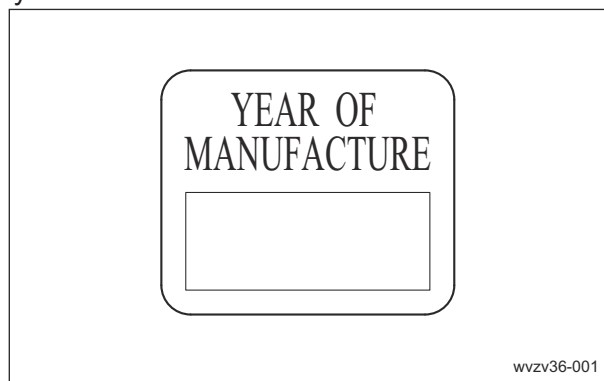

Year of Manufacture Decal_001

ROPS Compliance Decal

The ROPS compliance decal indicates the manufacturer, model, etc., in accordance with International Standard ISO 21299:2009.

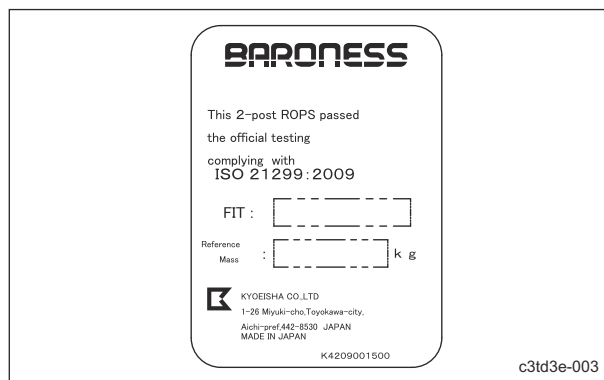

ROPS Compliance Decal_001

Product Overview

ROPS Caution Decal

ROPS caution decal describes the following caution messages.

- Replace damaged ROPS.
- Do not repair or revise.



ROPS Caution Decal_001

California Proposition 65 Decal (Riding Type)

(For the State of California, USA)

California Proposition 65 decal describes the warning messages as required by California Proposition 65.

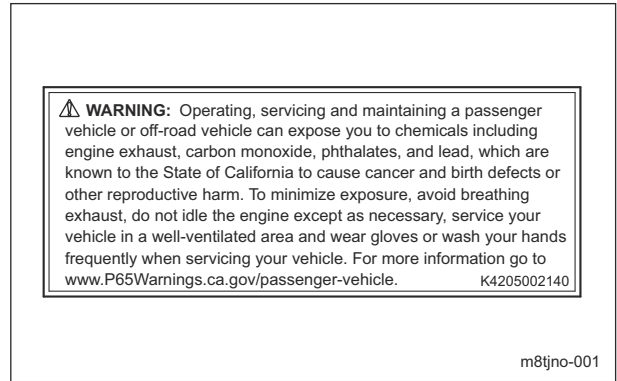

California Proposition 65 Decal (Riding Type)_001

Indicating Diesel Fuel Decal

(for USA)

It indicates the fuel to be used.

Use low sulfur or ultra-low sulfur diesel fuel (sulfur-free diesel fuel).

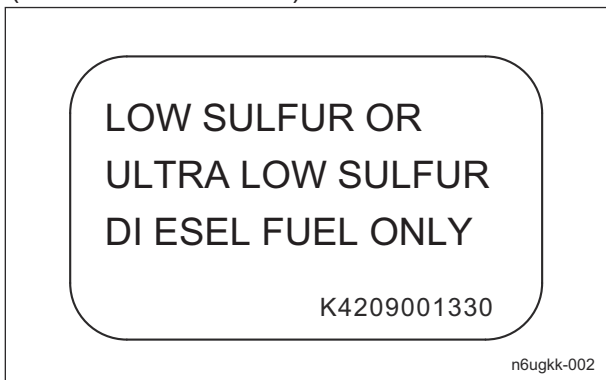

Indicating Diesel Fuel Decal_001

Spark Arrester Warning Decal

(For the State of California, USA)

Spark arrester warning decal describes the warning messages as required by California Public Resources Code.

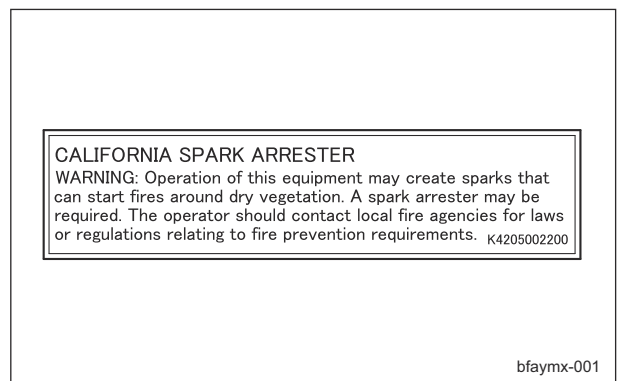

Spark Arrester Warning Decal_001

ISED Compliance Decal

(For Canada)

The ISED compliance decal indicates that the product marketed in Canada meets Canadian standard.

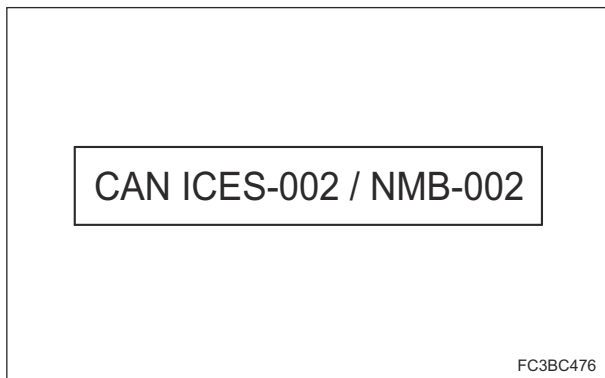

ISED Compliance Decal_001

Battery Capacity Decal

(For EU)

The battery capacity decal indicates the capacity by 20HR and CCA.

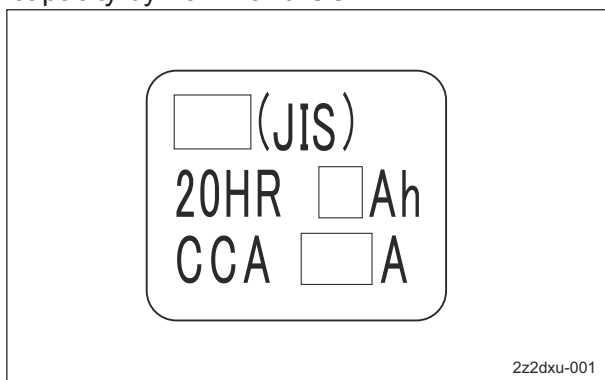

Battery Capacity Decal_001

EU Battery Regulation Decal

(For EU)

The EU battery regulation decal indicates compliance with the EU battery regulation.

- The following information about the battery manufacturing company is written in the decal.
 - Company name
 - Address
 - Website URL
- You can scan the QR code with your smartphone to access the corresponding battery information.
(*QR Code is a registered trademark of DENSO WAVE INCORPORATED.)
- CE mark indicates that the battery installed in a machine sold in the EU nations complies with the EU requirements.

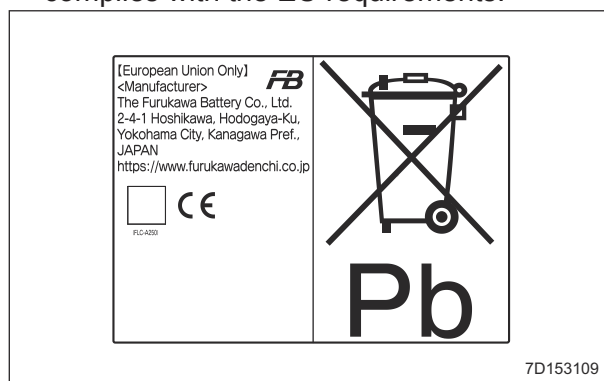

EU Battery Regulation Decal_001

Product Overview

Recycle Decal

Recycle Decal illustrates Recycle Mark in accordance with local regulation.
(For EU)

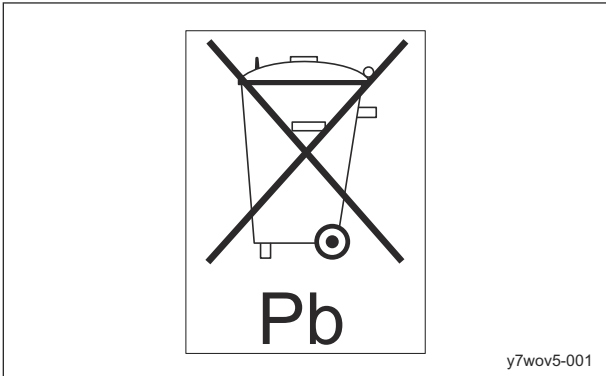

Recycle Decal_001

(For USA)



Recycle Decal_002

Battery Danger Decal

(For USA)
Battery Danger Decal describes handling precautions for battery.

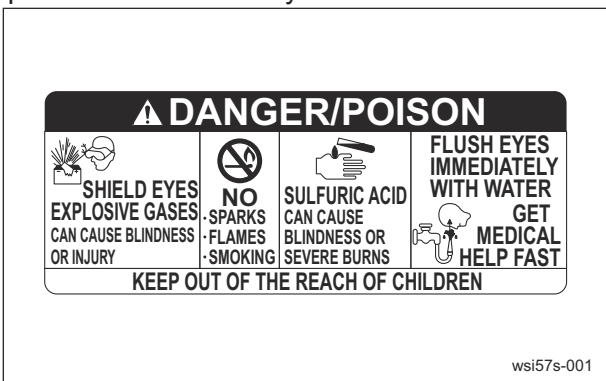

Battery Danger Decal_001

Safety Signs and Instruction Signs

About Safety Signs and Instruction Signs

Important

Safety decals and instruction decals are attached to this product. Make sure that they are preserved in their entirety. If they are damaged, become dirty, or peel off, replace them with new ones.

Part numbers for decals that need to be replaced are listed in the parts catalog. Order them from a Baroness dealer or Kyo-eisha.

Positions of Safety Decals and Instruction Decals

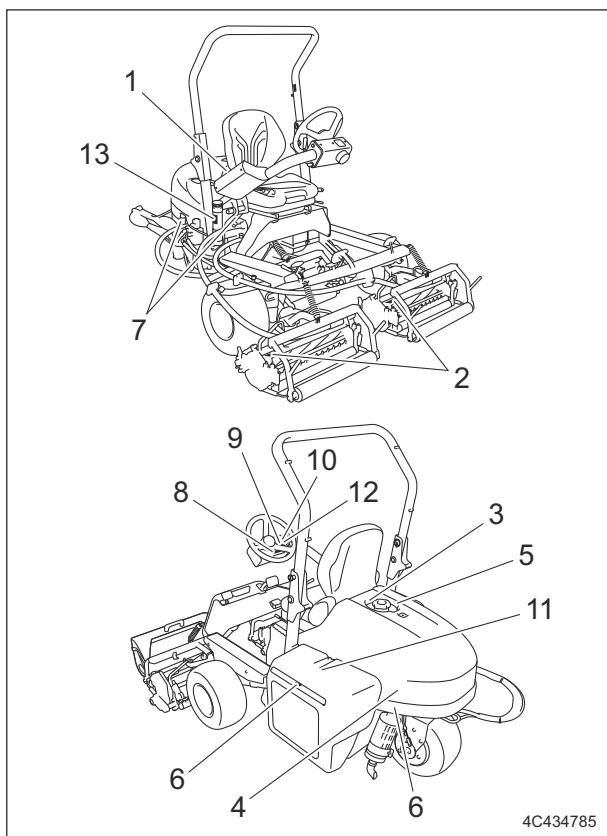

Positions of Safety Decals and Instruction Decals_001

1	D operation decal
2	Caution to mutilation decal
3	Fire prohibited decal
4	Hydraulic oil decal
5	Diesel fuel decal
6	Caution for high temperatures decal
7	Caution for getting entangled decal
8	Caution slope decal
9	Caution exhaust gas and flying object decal
10	Caution for slopes (3WD) decal
11	Caution for spouting coolant decal
12	Caution to noise decal
13	Decal on reading owner's operating manual (- #31977)

Description of Safety Decals and Instruction Decals

D Operation Decal

LM315GC0504B0
Decal D, operation

1.

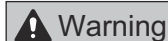

Read the Owner's Operating Manual.

2.



Apply the parking brake, stop the engine, and then remove the ignition key before leaving the machine.

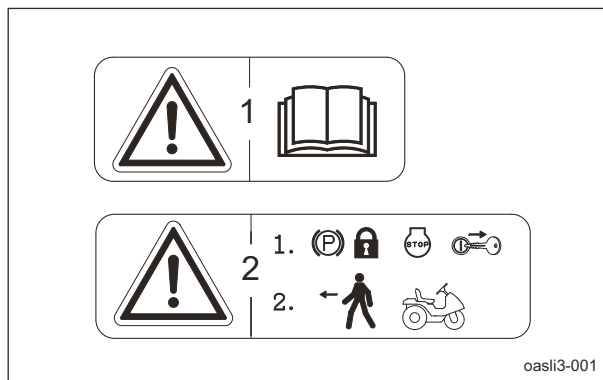

D Operation Decal_001

Product Overview

Caution to Mutilation Decal

K4205001600
DECAL, CAUTION TO MUTILATION

Warning

May cut your hand or leg - Stop the cutter rotation and engine. Otherwise you may get injured.

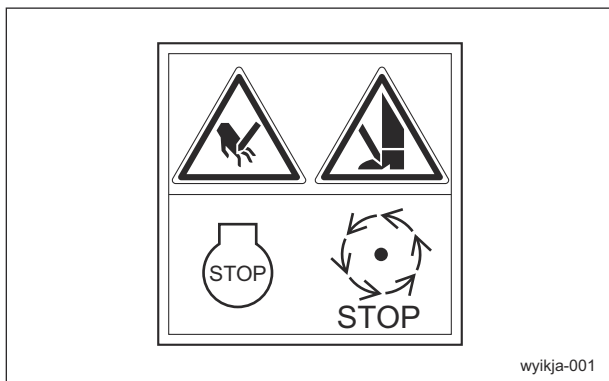

Caution to Mutilation Decal_001

Fire Prohibited Decal

K4205001940
Decal, fire prohibited

Warning

Keep away from fire.



Fire Prohibited Decal_001

Hydraulic Oil Decal

K4209001390
Decal, hydraulic oil
Read the owner's operating manual.

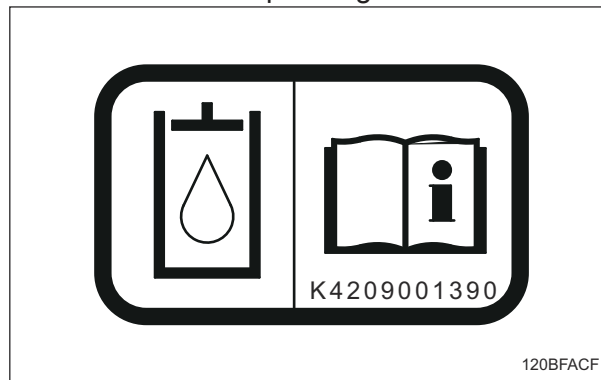

Hydraulic Oil Decal_001

Diesel Fuel Decal

K4209001460
Decal, diesel fuel
Use diesel fuel.

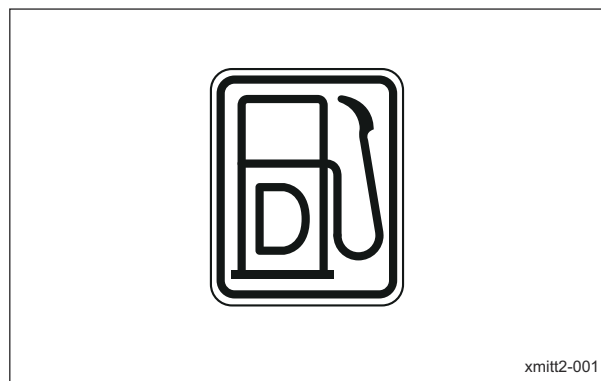

Diesel Fuel Decal_001

Caution for High Temperatures Decal

K4205001920
Decal, caution for high temperatures

Caution

High temperature - Do not touch. Otherwise, you will get burned.



xekv4l-001

Caution for High Temperatures Decal_001

Caution for Getting Entangled Decal

K4205001910
DECAL, CAUTION NOT TO GET CAUGHT IN

Warning

Watch for rotating parts - Keep your hands away from the belts while the engine is running.

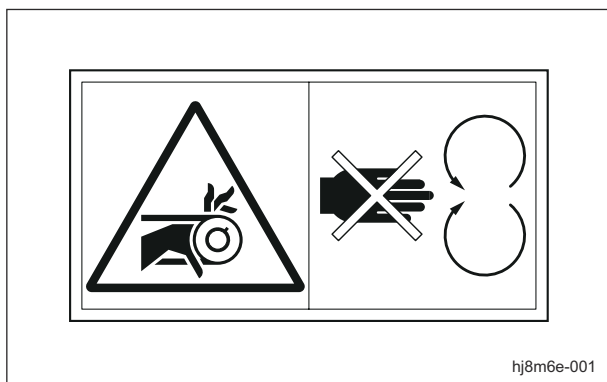

hj8m6e-001

Caution for Getting Entangled Decal_001

Caution Slope Decal

K4205002040
Decal, caution slope

Caution

Rollover - Do not work on slopes of 15 degrees or more. When you descend a slope, drive at low speed with the mower units lowered. Fasten your seatbelt when the machine is equipped with ROPS.

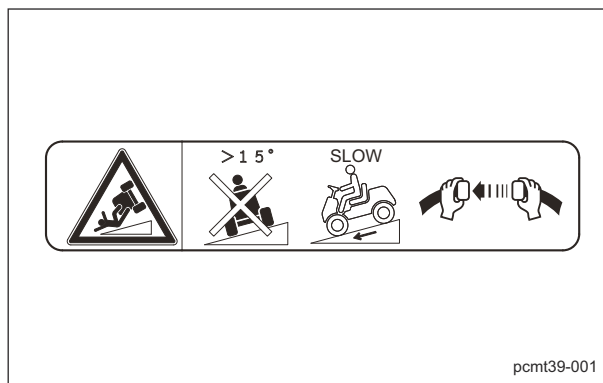

pcmt39-001

Caution Slope Decal_001

Product Overview

Caution for Scattering Exhaust Gas Decal

K4205002050

Decal, caution scattering exhaust gas

Warning

Caution to exhaust gas diffusion - All persons other than the operator must keep a safe distance from the machine.

Caution

Thrown objects - Be sure that people around the machine keep a safe distance away.

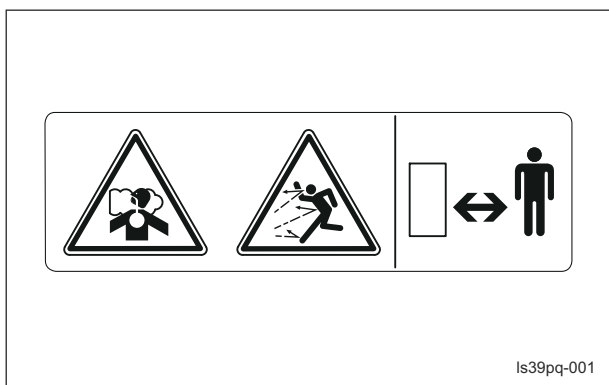

Caution for Scattering Exhaust Gas Decal_001

Caution for Slopes (3WD) Decal

K4205002080

Decal, caution for slopes (3WD)
(3WD spec model only)

Warning

Rollover - Do not switch between 2WD and 3WD while traveling on downward slopes. Do not set the reel rotation switch to the "Rotation" position while traveling on downward slopes. Do not travel in three-wheel drive on downward slopes.

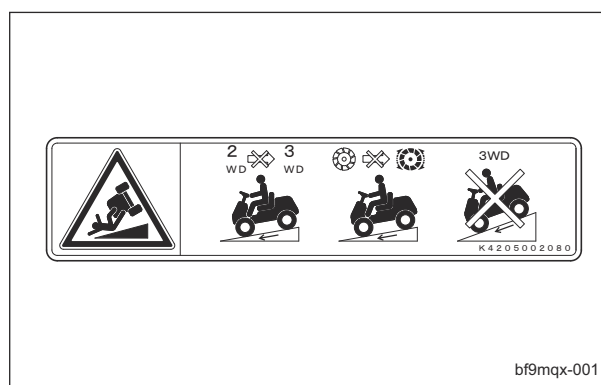

Caution for Slopes (3WD) Decal_001

Caution for Spouting Coolant Decal

K4205001970

Decal, caution for spouting coolant

Caution

Caution for spouting coolant - Do not open while hot. High temperature - Do not touch. Otherwise, you will get burned.

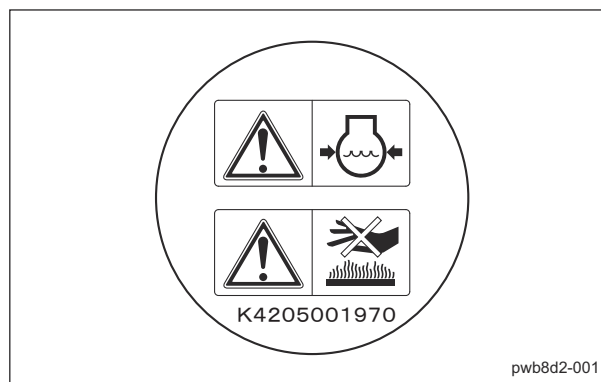

Caution for Spouting Coolant Decal_001

Caution to Noise Decal

K4205002090

Decal, caution to noise

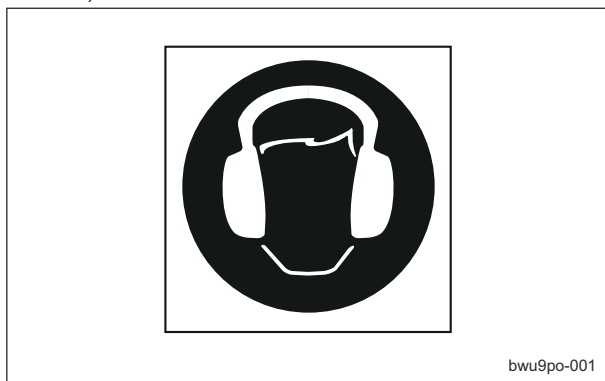

Caution to Noise Decal_001

Decal on Reading Owner's Operating Manual

K4205001560

Decal, read Owner's Operating Manual

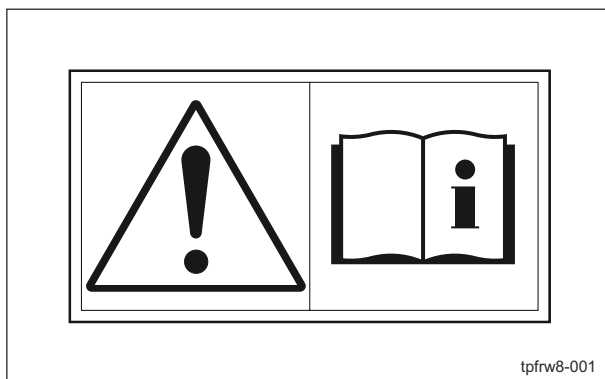
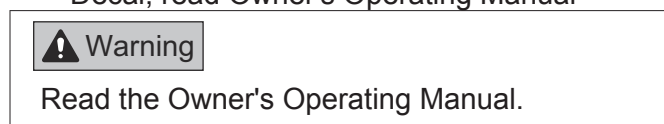

Decal on Reading Owner's Operating Manual_001

Product Overview

Operation Decals

Positions of Operation Decals

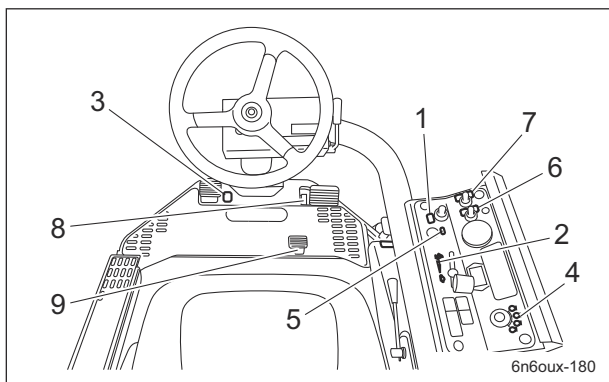

Positions of Operation Decals_001

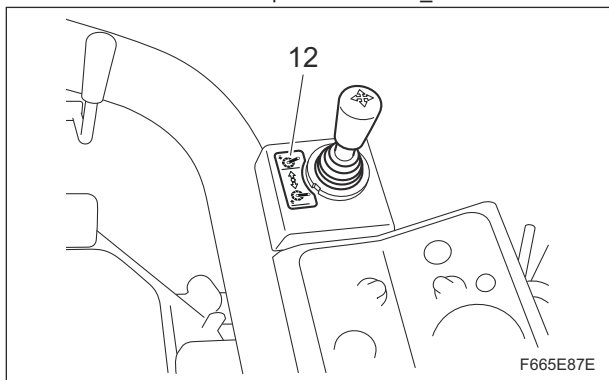

Positions of Operation Decals_002

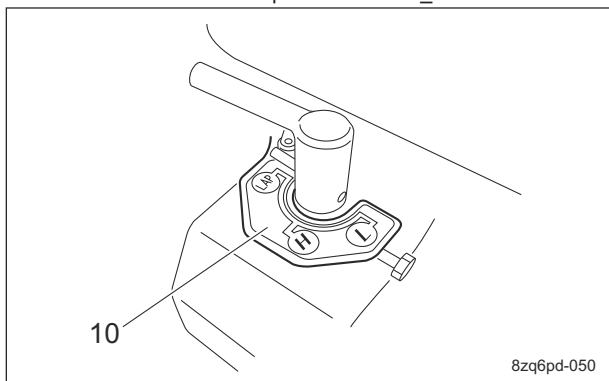

Positions of Operation Decals_003

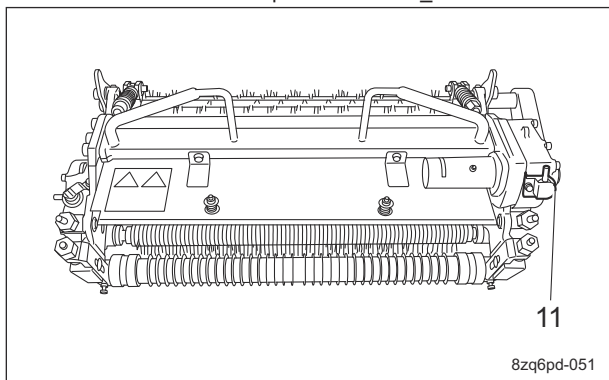

Positions of Operation Decals_004

1	Reel rotation/stop mark
2	Engine rotation mark
3	Mower unit Up/Down decal (For mower pedal model)
4	Key switch mark
5	Mower unit up-switch (with reel excess discharge system) mark
6	2WD/3WD changeover decal
7	Light switch decal
8	FORWARD Decal
9	BACKWARD Decal
10	Position decal
11	Mower unit reel rotation changeover decal
12	Mower unit Up/Down decal (For joystick model)

Description of Operation Decals

Reel Rotation/Stop Mark

Reel rotation/stop mark
It illustrates Rotation/Stop of the reel cutter (cutting cylinder).

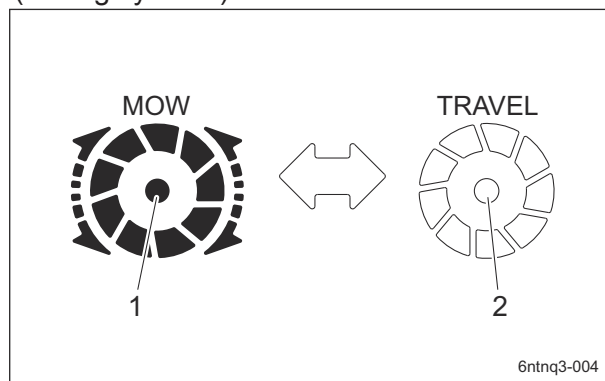

Reel Rotation/Stop Mark_001

1	Rotation
2	Stop

Engine Rotation Mark

Engine rotation mark
This indicates low/high speed of engine rotation.

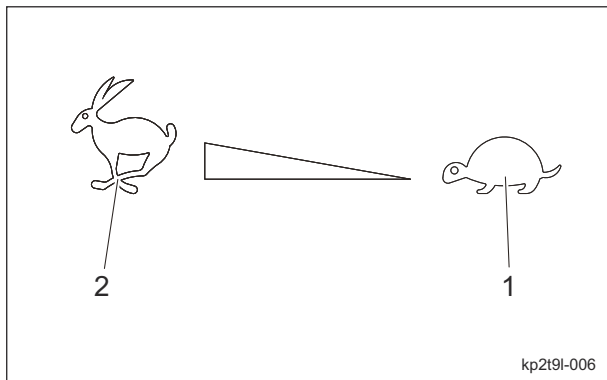

Engine Rotation Mark_001

1	Low speed
2	High speed

Mower Unit Up/Down Decal

K4203001730
Decal, lifting units
This indicates up-down of the mower unit.

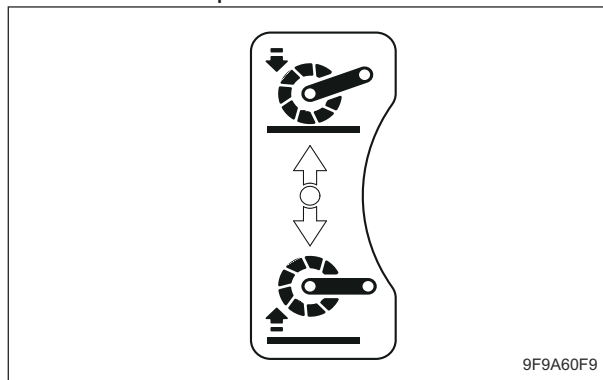

Mower Unit Up/Down Decal_001

Mower Unit Up/Down Decal

K4203001520
Decal, lifting units
This indicates up-down of the mower unit.

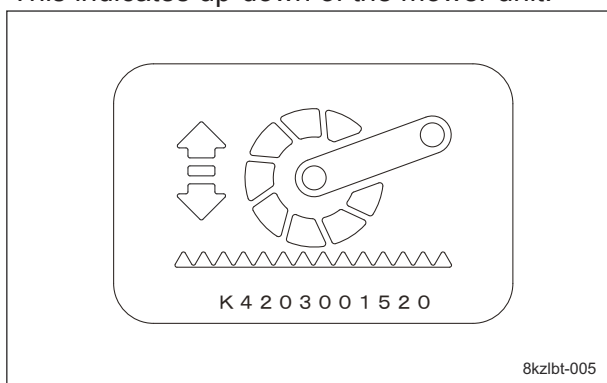

Mower Unit Up/Down Decal_001

Key Switch Mark

Key switch mark
This indicates the key switch positions.

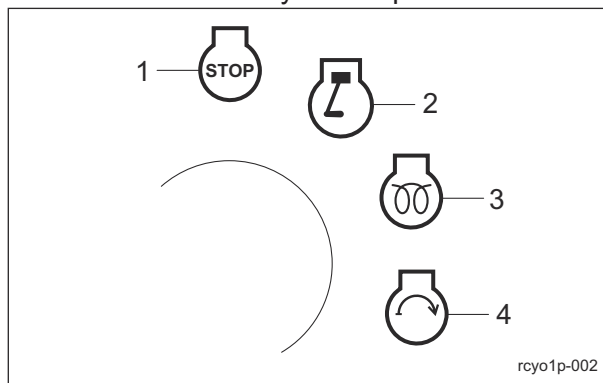

Key Switch Mark_001

1	OFF
2	ON
3	GLOW
4	START

Product Overview

Mower Unit Up-Switch (with Reel Excess Discharge System) Mark

Mower unit up-switch (with reel excess discharge system) mark
 This indicates mower unit up-switch and reel excess discharge system.

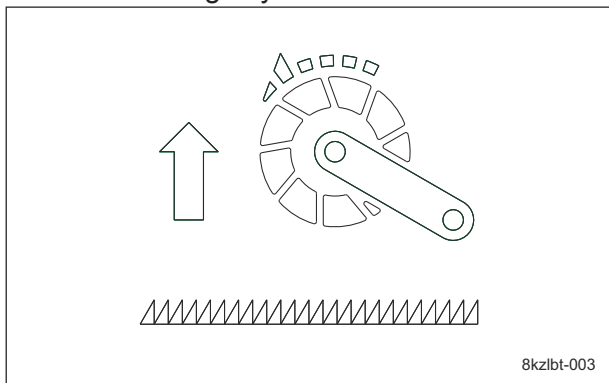

Mower Unit Up-Switch (with Reel Excess Discharge System) Mark_001

Light Switch Mark

Note:
 Depending on the specifications, this function may not be available.
 K4203001610
 DECAL, LIGHT SWITCH
 It illustrates ON/OFF of the light.

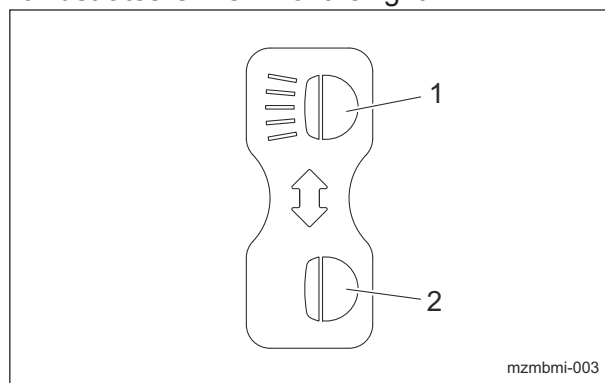

Light Switch Mark_001

1	ON
2	OFF

2WD/3WD Changeover Decal

Note:
 Depending on the specifications, this function may not be available.
 K4203001620
 Decal, shifting 2WD/3WD
 This indicates 2WD/3WD changeover.

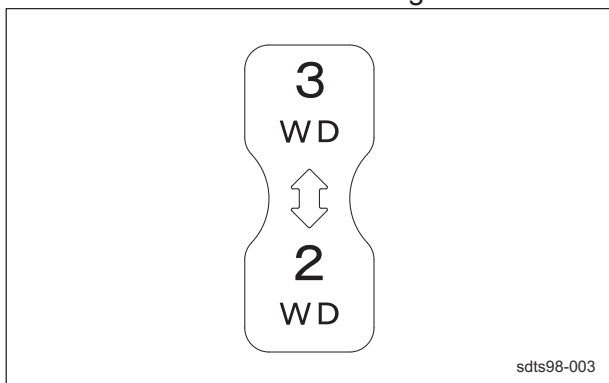

2WD/3WD Changeover Decal_001

FORWARD Decal

K4203001430
 Decal, FORWARD
 This indicates forward travel.



FORWARD Decal_001

Product Overview

BACKWARD Decal

K4203001440
Decal, BACKWARD
This indicates backward travel.

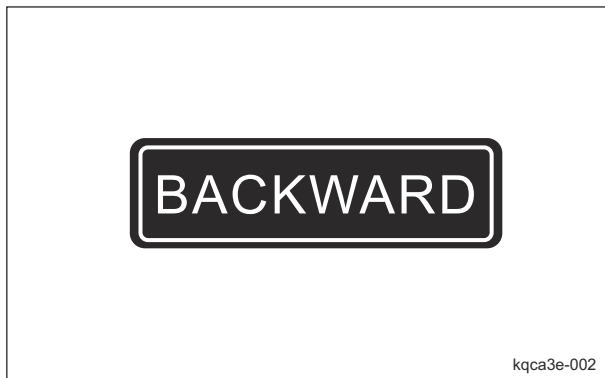

BACKWARD Decal_001

Position Decal

LM315GC1418Z0
Decal, position
This indicates changeover of High/Low speed of reel cutter rotation and back lapping rotation.

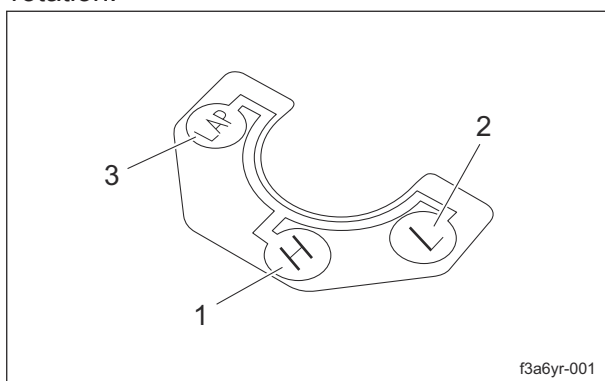

Position Decal_001

1	High speed
2	Low speed
3	Back lapping

Mower Unit Reel Rotation Changeover Decal

K4203001550
Sticker, rotating direction
This indicates changeover of normal rotation, neutral and reverse rotation of mower unit reel cutter.

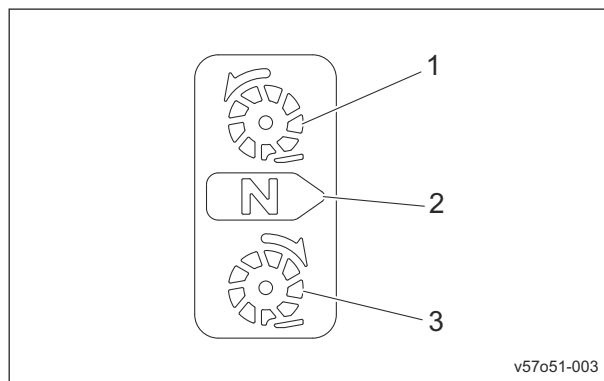

Mower Unit Reel Rotation Changeover Decal_001

1	Normal rotation (cutting rotation)
2	Neutral
3	Reverse rotation (back lapping rotation)

Product Overview

Description of Functions

Light Switch	Page 4-2
Throttle Lever	Page 4-2
Key Switch	Page 4-2
Mower Pedal	Page 4-3
Joystick	Page 4-3
Mower Unit Up Switch	Page 4-4
Up Switch (with Reel Excess Discharge System)	Page 4-4
2WD/3WD Selector Switch	Page 4-5
Reel Rotation Switch	Page 4-5
Reel Reverse Lever	Page 4-6
Transmission Selector Lever	Page 4-6
Traveling Pedal	Page 4-7
Parking Brake Lever	Page 4-7
Broom Holder	Page 4-8
Swisher Holder	Page 4-8
Instruments on The Operation	
Panel	Page 4-8
Hour Meter	Page 4-8
Water Temperature Gauge	Page 4-9
Pilot Lamps	Page 4-9
Fuel Gauge	Page 4-10
Safety Device	Page 4-10
Interlock System	Page 4-10
Warning Mechanisms	Page 4-10
Warning Buzzer	Page 4-10

Description of Functions

Light Switch

Note:
Depending on the specifications, this function may not be available.
The light switch is located in the operation panel.
Flip the switch up to turn the light on, and down to turn the light off.

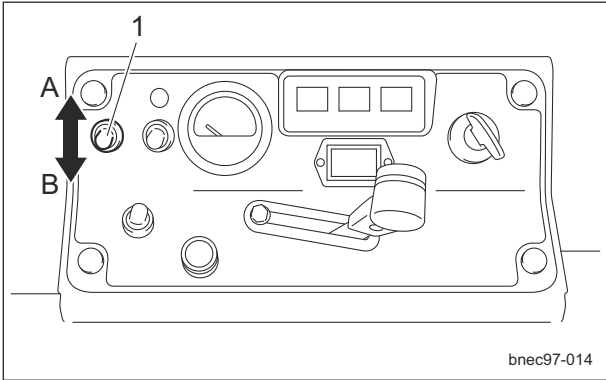

Light Switch_001

1	Light switch
A	ON
B	OFF

Key Switch

The key switch is a lock for inserting the ignition key.
This is used to start, run or stop the engine by turning the ignition key to change the key switch position.

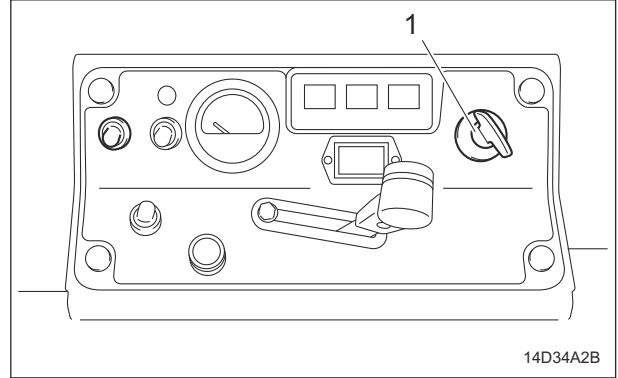

Key Switch_001

1	Key switch
---	------------

Throttle Lever

The throttle lever is located in the operation panel and enables you to adjust the engine rpm.
Move the throttle lever toward the "High speed" to increase the engine rpm, and toward the "Low speed" to reduce the rpm.

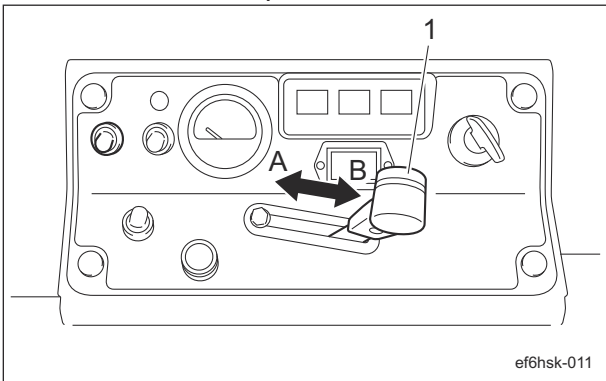

Throttle Lever_001

1	Throttle lever
A	High speed
B	Low speed

Description of Functions

Mower Pedal

Note:
Depending on the specifications, this function may not be available.

Caution

Do not keep depressing the mower pedal after an operation. It may cause malfunction.

Important

Even if the reel rotation switch is set to the "Rotation" position, when the mower units are raised, the reel cutters (cutting cylinders) stop rotating.

Important

Operation of the mower pedal cannot raise the mower units to the highest position. When traveling, keep pressing the up switch to raise the mower units to the highest position.

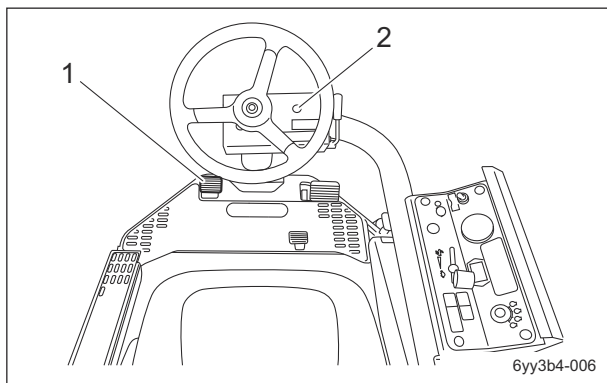

Mower Pedal_001

1	Mower pedal
2	Green LED

The mower pedal is located on the left of the foot area in front of the driver's seat. Depressing the pedal switches the mower units between the up and down positions. When it is switched to the down position, the green LED on the steering column lights up. The Up/Down speed of the mower unit is affected by the engine rotation speed. When the engine rotation is at low speed, the Up/Down speed is at low as well.

Joystick

Note:
Depending on the specifications, this function may not be available.

Important

Even if the reel rotation switch is set to the "Rotation" position, when the mower units are raised, the reel cutters (cutting cylinders) stop rotating.

Important

Operation of the joystick cannot raise the mower units to the highest position. When traveling, keep pressing the up switch to raise the mower units to the highest position.

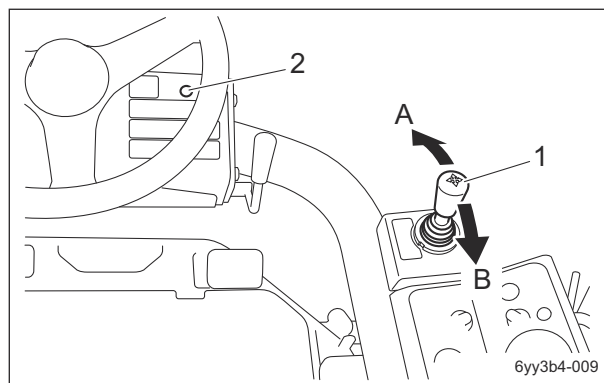

Joystick_001

1	Joystick
2	Green LED lamp
A	Down
B	Up

Tilting the joystick back and forth switches the mower units between the up and down positions. Only while the joystick tilted to the "Down" position, the green LED on the steering column lights up. The Up/Down speed of the mower unit is affected by the engine rotation speed. When the engine rotation is at low speed, the Up/Down speed is at low as well.

Description of Functions

Mower Unit Up Switch

Up Switch (with Reel Excess Discharge System)

Warning

The reel cutter rotates while holding down the up switch when the reel rotation switch is set to the "Rotation" position.

Set the reel rotation switch to the "Stop" position except during mowing or backlapping and using reel excess discharge system.

Warning

The reel cutter rotates when using reel excess discharge system.

Keep hands and feet away from moving parts.

Caution

Before using reel excess discharge system, make sure that there are no people around the machine.

Important

Do not press the up switch when the mower unit is at lowered position. Otherwise, the harness will get damaged.

Important

The reel cutter keeps rotating even if the mower unit raised to the highest position while holding down the up-switch.

Up Switch

The up switch is located in the operation panel.

If the height of the mower unit is not sufficient for traveling etc, set the reel rotation switch to the "Stop" position and keep pressing the up switch to operate the magnetic valve to raise the mower unit to the highest position.

Reel excess discharge system

Reel excess discharge system is the function to remove clippings inside the reel cutter by rotating the reel cutter with the up switch on the condition that the mower unit raised and the reel rotation switch set to the "Rotation" position.

With this function, falling of lumps of clippings can be prevented during mowing operation and the time of washing the vehicle can be shortened.

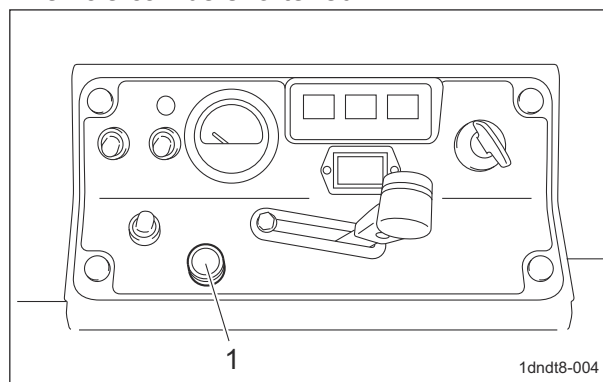

Up Switch (with Reel Excess Discharge System)_001

1	Up Switch(with reel excess discharge system)
---	--

Description of Functions

2WD/3WD Selector Switch

Caution

In case of 2WD/3WD model, travel in 2WD mode since it is dangerous to travel on steep downward slopes, wet road surface or downward slopes of wet lawn in 3WD mode. Rear tire going into a skid may cause loss of traveling control.

Important

When the reel rotation switch is set to the "Rotation" position, regardless of the position of the 2WD/3WD selector switch, 3WD is selected.
When the traveling mode is switched to 3WD, the red LED in front of the 2WD/3WD selector switch lights up.

Important

When switching between 2WD and 3WD operation, make sure to stop the machine completely. Otherwise, the hydraulic system will malfunction.

Note:

Depending on the specifications, this function may not be available.
The 2WD/3WD selector switch is located in the operation panel.
Flip the switch to the "2WD" position to select 2WD mode, and flip it to the "3WD" position to select 3WD mode.
When the traveling mode is switched to 3WD, the red LED above the 2WD/3WD selector switch lights up.

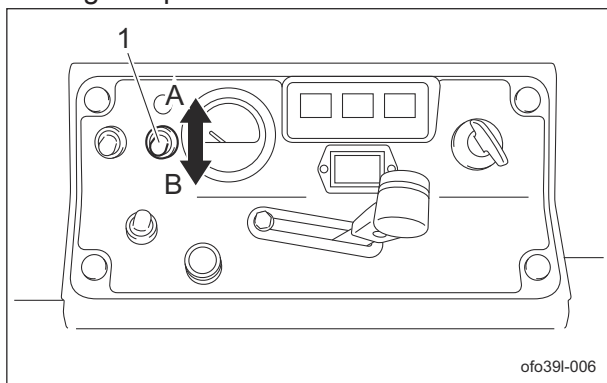

2WD/3WD Selector Switch_001

1	2WD/3WD selector switch
A	3WD
B	2WD

Reel Rotation Switch

Warning

The reel cutter rotates while holding down the up switch when the reel rotation switch is set to the "Rotation" position.
Set the reel rotation switch to the "Stop" position except during mowing or backlapping and using reel excess discharge system.

Caution

In case of 2WD/3WD model, travel in 2WD mode since it is dangerous to travel on steep downward slopes, wet road surface or downward slopes of wet lawn in 3WD mode. Rear tire going into a skid may cause loss of traveling control.

Important

In case of 2WD/3WD model, whenever the reel rotation switch is set to the "Rotation" position, the drive mode is put into 3WD regardless of the position of the 2WD/3WD selector switch.

The reel rotation switch is located in the operation panel. Setting the switch to the "Rotation" position rotates the reel, and to the "Stop" position stops the reel.

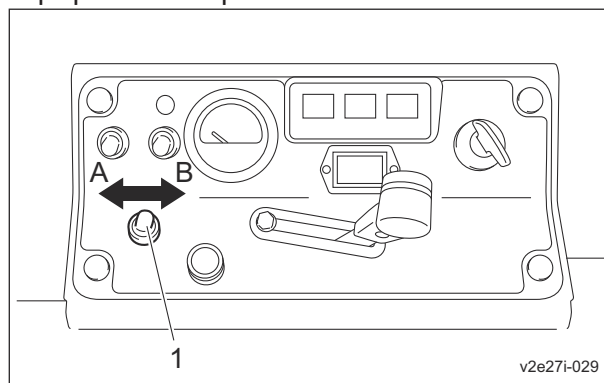

Reel Rotation Switch_001

1	Reel rotation switch
A	Rotate
B	Stop

Description of Functions

When the reel rotation switch is set to the "Rotation" position, the reel cutters (cutting cylinders) will rotate or stop in sync with the up and down motion of the mower units. When the mower units are lowered, the reel cutters (cutting cylinders) rotate, and when the mower units are raised, they stop.

1. When the mower units are lowered, the sensor activates the electromagnetic clutch, and the reel cutters (cutting cylinders) start rotating by means of the flexible wire.
2. When the mower units are raised, even if the reel rotation switch is set to the "Rotation" position, the sensor does not activate the electromagnetic clutch, and the reel cutters (cutting cylinders) do not rotate.

Reel Reverse Lever

Important

Operate the reel reverse lever while the rotation of the reel cutter (cutting cylinder) is stopped, and adjust it to the position suitable for your work.

The reel reverse lever is located at the upper part of the gear case of the mower unit. If you set the lever to Normal, it starts cutting rotation, set to Reverse for back lapping rotation and Neutral for free rotation.

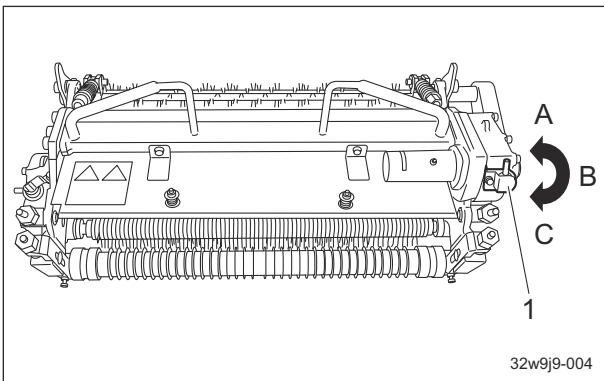

Reel Reverse Lever_001

1	Reel reverse lever
A	Normal rotation
B	Neutral
C	Reverse rotation

Transmission Selector Lever

Warning

Be sure to stop the engine before and during shifting the transmission selector. Otherwise, your hands may get caught in the belt.

Important

The transmission selector lever should be operated while the engine rotation is stopped, and adjusted to the position suitable for your work.

Important

For the LM315GC (for fields), normally cut with the lever set to the "Low speed" position.

The transmission selector lever is located at the upper part of the transmission, behind the driver's seat. When the lever is shifted to the "High speed" position the reel cutters (cutting cylinders) rotate fast; on "Low speed" they rotate slowly; on "Back lapping" they rotate more slowly, at a suitable speed for back lapping.

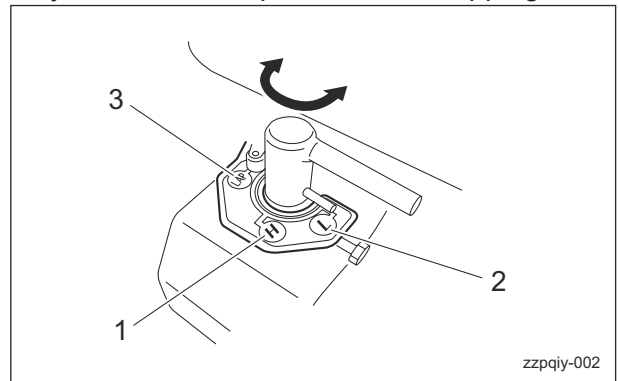

Transmission Selector Lever_001

1	High speed
2	Low speed
3	Back lapping

1. High speed (H)
The reel cutters (cutting cylinders) rotate faster, and the clip pitch (cutting interval) becomes shorter. This is suitable for the work at a good turf condition.

Description of Functions

2. Low speed (L)

The reel cutter (cutting cylinder) rotates slower compared to when it is at the "High speed" position and the clip pitch becomes longer.

This is suitable for the work at the turf condition not so good.

3. Back lapping (LAP)

The reel cutter (cutting cylinder) rotates in a speed suitable for the back lapping and its maintainability increases. (The rotation direction is not changed, so use the reel reverse lever of the mower unit to reverse the rotation).

1	Forward pedal
2	Reverse pedal

Traveling Pedal

⚠ Caution

When the machine is traveling at a high speed, it will not stop immediately after you take your foot off the traveling pedal.

Important

When the reel rotation switch is turned to the "Rotation" position the working speed is limited by the pedal stopper.

The traveling pedals are located in the right foot area and control forward and reverse operation of the machine.

When the forward pedal (front side) is depressed, the machine travels forward. When the reverse pedal (rear side) is depressed, the machine travels backward.

The speed changes in accordance with how much the pedal is depressed.

When you take your foot off the pedal, the machine stops automatically.

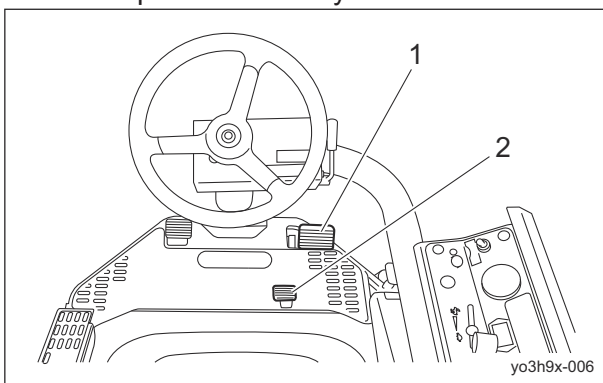

Traveling Pedal_001

Parking Brake Lever

⚠ Caution

Never park the machine on a slope.

Important

Be sure to release the parking brake before driving. Otherwise, it will cause the malfunction of the brake or hydraulic system.

The parking brake lever is located at the left of the driver's seat.

To park the machine, pull the parking brake lever completely.

To release the parking brake, press the push button while lowering the parking brake lever all the way to its resting position.

If the traveling pedal is depressed while the parking brake is applied, a buzzer will sound. (intermittent tone)

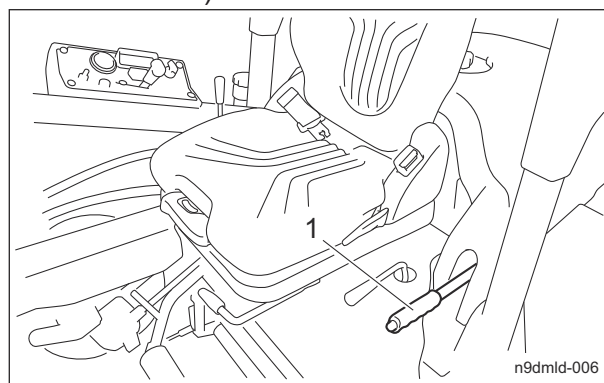

Parking Brake Lever_001

1	Parking brake lever
---	---------------------

Description of Functions

Broom Holder

Note:

Depending on the specifications, this function may not be available.

Broom can be stored in this holder for transport.

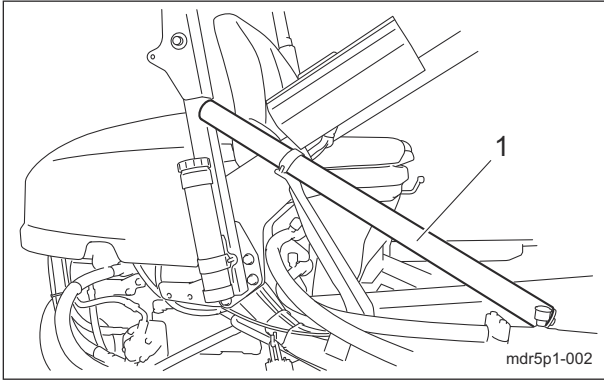

Broom Holder_001

1	Broom holder
---	--------------

Instruments on The Operation Panel

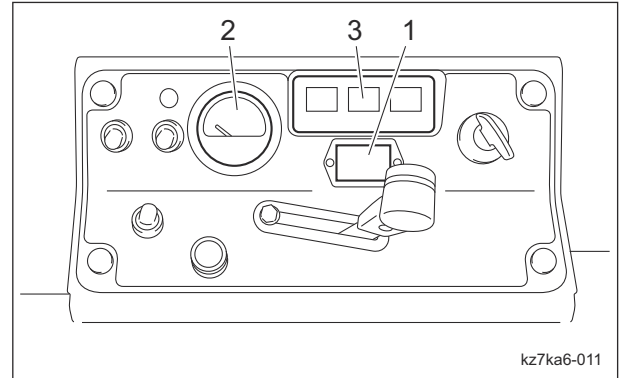

Instruments on The Operation Panel_001

1	Hour meter
2	Water temperature gauge
3	Pilot lamp

Hour Meter

The hour meter indicates the accumulated operation time of the engine.

The number in red figures on a white background is incremented every thirty-six seconds.

The number in white figures on a black background is incremented every hour.
1/100 wheel ... red figures on a white background

Hour wheel ... white figures on a black background

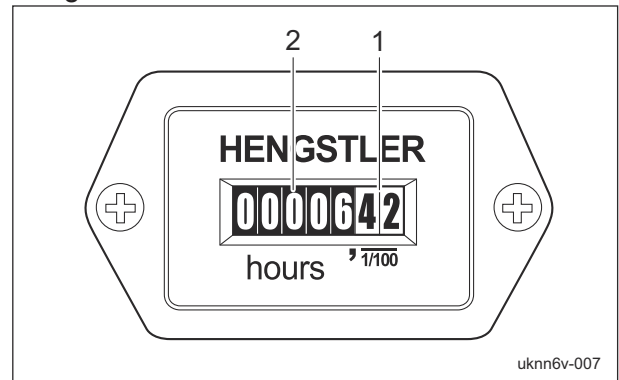

Hour Meter_001

1	1/100 wheel
2	Hour wheel

Swisher Holder

Note:

Depending on the specifications, this function may not be available.

Swisher pole can be stored in this holder for transport.

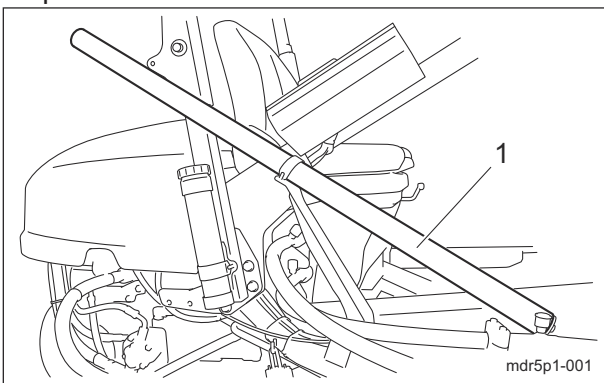

Swisher Holder_001

1	Swisher holder
---	----------------

Description of Functions

Water Temperature Gauge

This instrument indicates the water temperature inside the engine. If the water temperature gauge indicates a level close to "H" during operation, the machine is overheated. Remove the load from the engine, idle the machine for five minutes, stop the engine, and then inspect the machine and perform any necessary maintenance.

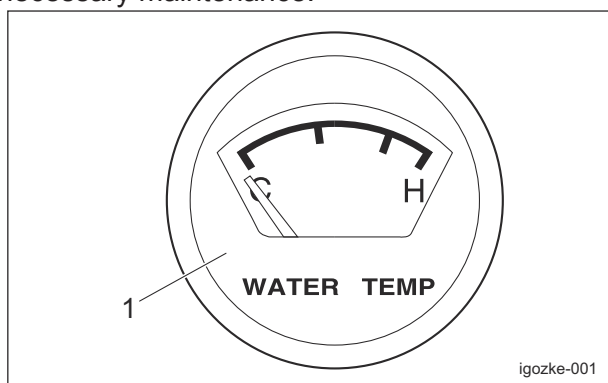

Water Temperature Gauge_001

1	Water temperature gauge
---	-------------------------

Pilot Lamps

Charge Lamp

The charge lamp is the left pilot lamp located in the operation panel. It turns on when the ignition key is set to the "ON" position before the engine starts. It turns off when the engine starts and the alternator starts operating properly. If this lamp illuminates while you are operating the machine, stop the engine immediately, and then inspect the machine and perform any necessary maintenance.

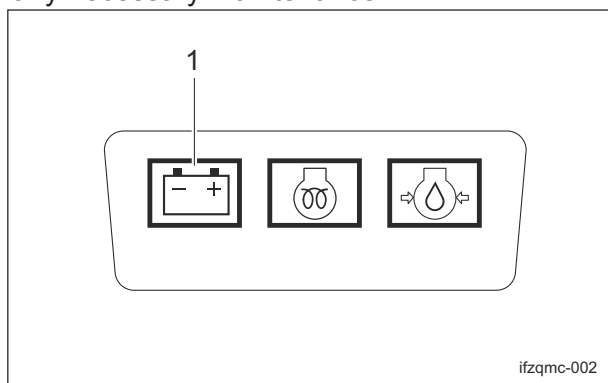

Charge Lamp_001

1	Charge lamp
---	-------------

Thermo-Start Lamp

The thermo-start lamp is the middle pilot lamp located in the operation panel. When the ignition key is set to the "GLOW" position, it illuminates as the glow plug generates heat. Illumination of the thermo-start lamp is controlled by the glow lamp timer, and the lamp is turned off after a specified amount of time passes. The duration of illumination indicates an approximate period of time required for warm-up, and has been fixed at five seconds.

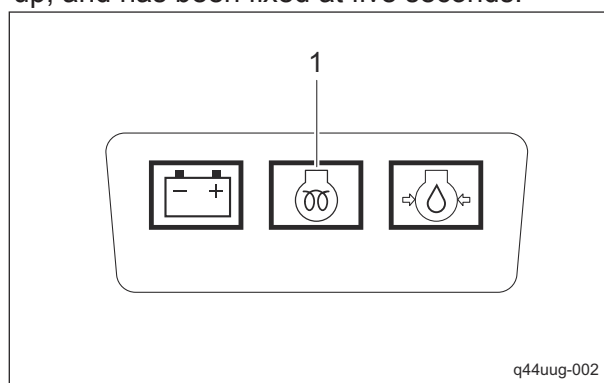

Thermo-Start Lamp_001

1	Thermo-start lamp
---	-------------------

Oil Pressure Lamp

The oil pressure lamp is the right pilot lamp located in the operation panel. It turns on when the ignition key is set to the "ON" position before the engine starts. It turns off when the engine starts and engine oil pressure is generated properly. If this lamp illuminates while you are operating the machine, stop the engine immediately, and then inspect the machine and perform any necessary maintenance.

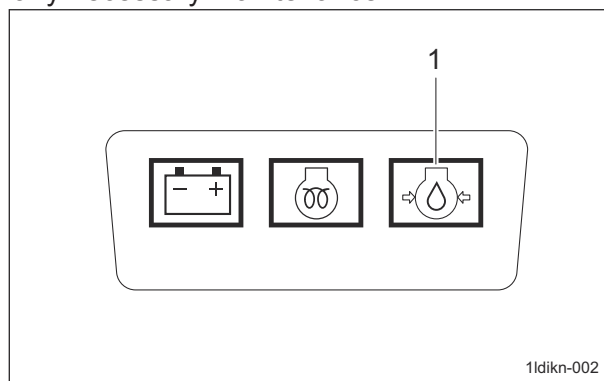

Oil Pressure Lamp_001

1	Oil pressure lamp
---	-------------------

Description of Functions

Fuel Gauge

The fuel gauge is located on the fuel tank. This instrument indicates the quantity of fuel inside the fuel tank.

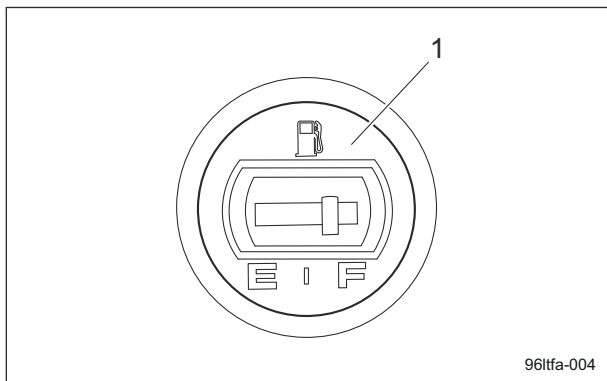

1	Fuel gauge
---	------------

Safety Device

Interlock System

This machine features a safety device for starting/stopping the engine.

1. As for starting the engine, the safety device prevents the engine from starting unless it meets each of the following four conditions.
 - An operator is sitting on the seat.
 - The parking brake is applied.
 - The reel rotation switch is set to the "Stop" position.
 - The traveling pedal is set to the neutral position.
2. In the event the operator leaves the seat with the parking brake not applied and the engine running, the safety device will be activated and will stop the engine.
3. In the event the operator leaves the seat with the parking brake applied and the engine running, the safety device will be activated and will stop the engine under the following conditions.
 - The traveling pedal is not set to the neutral position. (The operator has depressed the traveling pedal.)
 - The reel rotation switch is set to the "Rotation" position.

However, when the transmission selector lever is set to the "LAP" position, engine will not stop.

Warning Mechanisms

Warning Buzzer

1. Overheat warning buzzer

If the water temperature inside the engine exceeds 105 °C (221 °F), a buzzer will sound. (intermittent tone)

If the water temperature gauge indicates a level above the "H" when the buzzer sounds, the engine is overheated.

5 minutes after idling the engine with no load, stop the engine and inspect the machine and perform any necessary maintenance.
2. Hydraulic oil level warning buzzer

If the oil level in the hydraulic tank decreases by approximately 1.2 dm³ (1.2 L) from the specified level, a buzzer will sound. (intermittent tone)

When the buzzer sounds, stop the engine immediately, and then inspect the machine and perform any necessary maintenance.
3. Warning buzzer for traveling with brake applied

If the traveling pedal is depressed while the parking brake is applied, a buzzer will sound. (intermittent tone)

When the buzzer sounds, release the parking brake.

Operations before Service Page 5-2

Procedure to Open/Close Hood Page 5-2

Procedure to Open/Close Underseat
Cover Page 5-2

Procedure to Open/Close Radiator
Cover Page 5-3

Inspection before Use Page 5-3

EnginePage 5-3

Main Vehicle Page 5-6

Mower UnitPage 5-10

Adjustment before Work Page 5-11

Main VehiclePage 5-11

Mounting and Dismounting Page 5-13

Procedure to Mount/Dismount Page 5-13

Start/Stop of Engine Page 5-13

Procedure to Start Engine Page 5-13

Procedure to Stop Engine Page 5-14

Parking and StoppingPage 5-15

Procedure to Leave The Machine Page 5-15

MovePage 5-15

Traveling Procedure Page 5-15

Cutting Work Page 5-16

Cutting ProcedurePage 5-16

Reel Excess Discharge SystemPage 5-17

Removing Grass Catcher Page 5-17

TransportingPage 5-18

Transporting Procedure Page 5-18

Cleaning after Use Page 5-18

EnginePage 5-18

Mower UnitPage 5-19

Storage Page 5-19

Short-Term Storage Page 5-19

Handling Instructions

Operations before Service

The following sections describe the preparatory works required before performing the services including inspection, adjustment, cleaning, maintenance and repair.

Procedure to Open/Close Hood

Caution
Do not open the hood in strong winds.

Caution
Be careful not to pinch your fingers when you open or close the hood.

1. Remove the bolt.
2. Lift up the hood.
3. Make sure that the hood will not close, and then remove your hands.

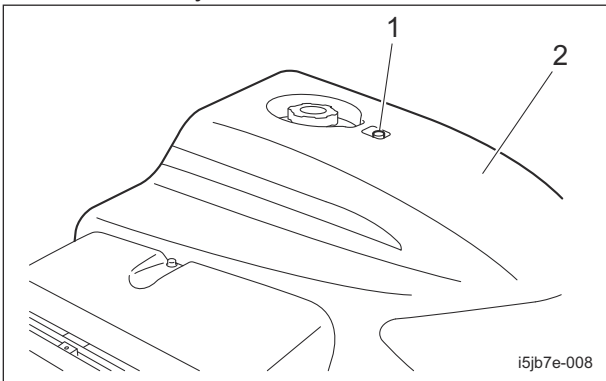

Procedure to Open/Close Hood_001

1	Bolt
2	Hood

4. When closing the hood, do the operation slowly.
5. Press the hood lightly and lock it with the bolt.

Procedure to Open/Close Underseat Cover

Caution
Be careful not to pinch your fingers when you open or close the underseat cover.

1. Remove the grass catcher located at the center.
"Removing Grass Catcher" (Page 5-17)

2. Adjust the steering wheel arm to the lowest position.
"Adjustment of Steering Wheel Position" (Page 5-12)
3. Slide the seat forward and rotate the lock lever 90 degrees anticlockwise.

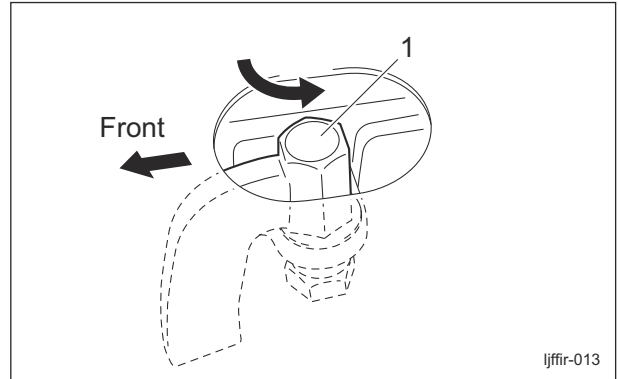

Procedure to Open/Close Underseat Cover_001

1	Lock lever
---	------------

4. Pull up the forward tilt angle adjustment lever and lift up the underseat cover together with the seat.

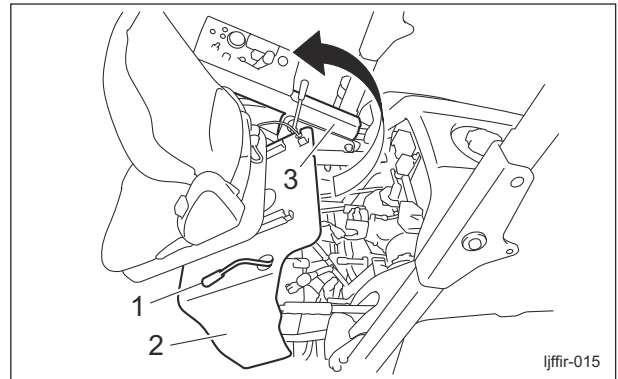

Procedure to Open/Close Underseat Cover_002

1	Forward tilt angle adjustment lever
2	Underseat cover
3	Steering wheel arm

5. When closing the underseat cover, do it slowly and be sure to use the forward tilt angle adjustment lever to fix it securely.

Handling Instructions

6. Rotate the lock lever 90 degrees clockwise to fix the underseat cover.

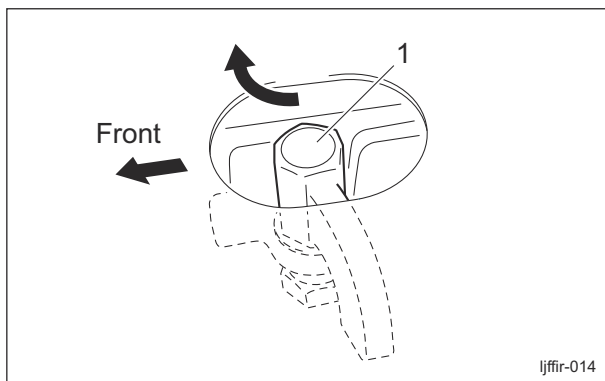

Procedure to Open/Close Underseat Cover_003

1	Lock lever
---	------------

Procedure to Open/Close Radiator Cover

1. Procedure to open the radiator cover:
 [1] Remove the bolt.
 [2] Remove the radiator cover.

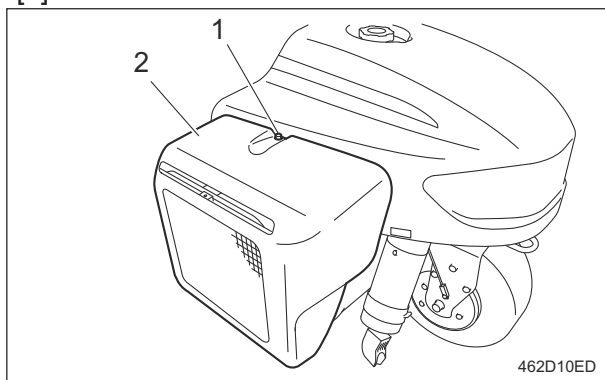

Procedure to Open/Close Radiator Cover_001

1	Bolt
2	Radiator cover

2. Procedure to close the radiator cover:
 [1] Install the radiator cover.
 [2] Install the bolt.

Inspection before Use

The purpose of the machine inspection is to:

- Prevent accidents
- Prevent damage to the machine
- Maintain machine performance

Detecting machine malfunctions early helps prevent unexpected problems from occurring. If you detect any abnormalities with the machine, immediately perform maintenance or repairs.

Engine

Inspection of Engine Oil

Important

Securely insert the oil level gauge.

Check the contamination of oil and engine oil level to inspect the engine oil. Inspect the engine oil level 10 to 20 minutes after stopping the engine.

1. Place the machine so that the engine is level.
2. Stop the engine.
3. Open the hood.
4. Pull out the oil level gauge.

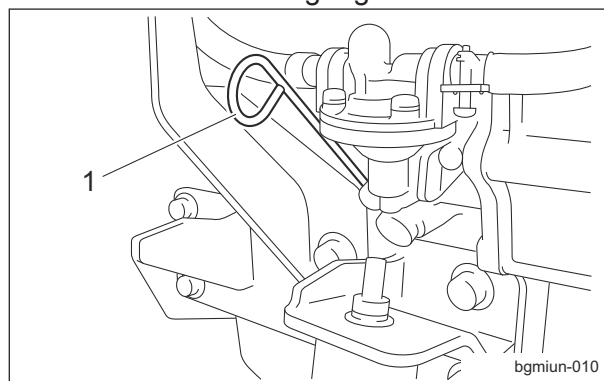

Inspection of Engine Oil_001

1	Oil level gauge
---	-----------------

5. Wipe the oil off the oil level gauge cleanly with papers or cloths.
6. After wiping the oil off the oil level gauge, check the contamination.
7. Return the oil level gauge to its original position, insert tightly, and pull out again.
8. Check the engine oil level.
 The appropriate oil level should be between the upper and lower limit lines on the gauge.

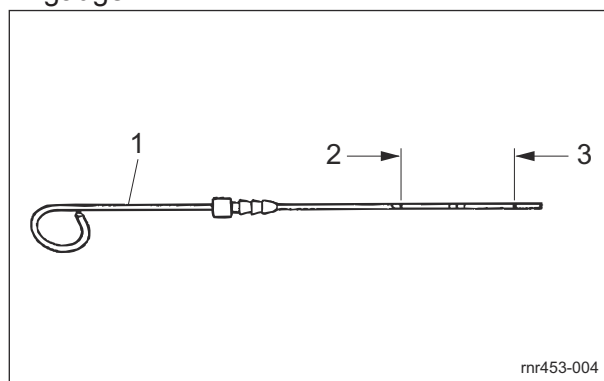

Inspection of Engine Oil_002

Handling Instructions

1	Oil level gauge
2	Upper limit
3	Lower limit

9. Return the oil level gauge to its original position, and insert it tightly.
10. Close the hood.

Inspection of Fuel Quantity

With the machine on a level surface, observe the fuel gauge on the fuel tank to check the fuel level.

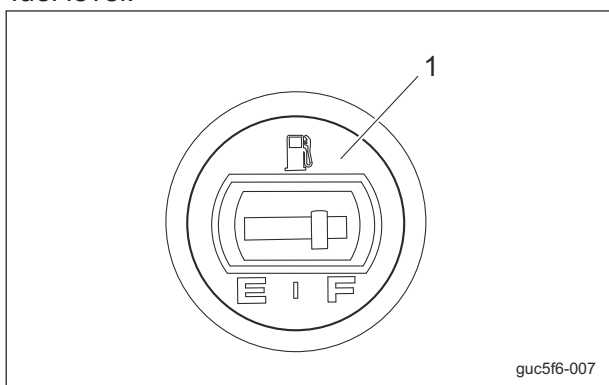

Inspection of Fuel Quantity_001

1	Fuel gauge
---	------------

Supply of Fuel

Warning

Supply fuel before starting the engine. Never remove the tank cap or supply fuel while the engine is running. When opening the tank cap, wait at least 1 minute after stopping the engine, and then slowly open the cap to release the pressure in the tank. Opening the tank cap quickly may cause fuel to burst out.

Warning

Keep fire away while refueling. Do not smoke while refueling.

Warning

Do not supply fuel above F (FULL) level of the fuel gauge. If you supply too much fuel, it might overflow from the fuel cap when you travel or work on a slope.

If the fuel gauge on the fuel tank indicates a level close to E (EMPTY), supply fuel (diesel) at your earliest convenience.

The fuel tank capacity is approximately 20.0 dm³ (20.0 L).

Note:

If the cargo box installed, slide it backward before supplying fuel.

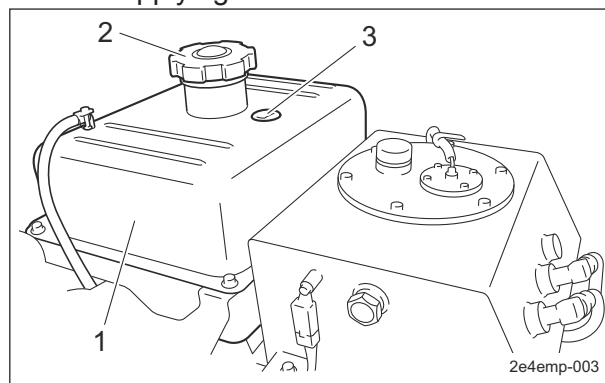

Supply of Fuel_001

1	Fuel tank
2	Tank cap
3	Fuel gauge

Air Bleeding of Fuel System

Important

Be sure to tighten the air-bleeding plug except when air bleeding. Otherwise, it may cause the engine stop.

This machine has a function of automatic air bleeding. However, depending on the mechanical structure, it may not bleed air completely. If the automatic air bleeding does not work well, follow the steps below to perform manual air bleeding.

1. Fill up the fuel tank with fuel and open the fuel cock.
2. Loosen the air-bleeding plug of the fuel filter 2 to 3 turns.

Handling Instructions

3. If air bubble of the fuel from the plug has gone, tighten the plug.

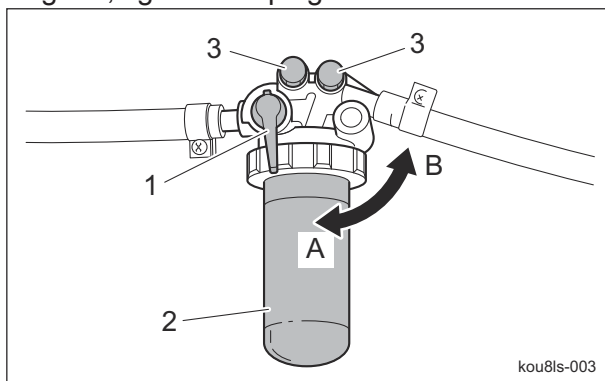

Air Bleeding of Fuel System_001

1	Fuel cock
2	Fuel filter
3	Air-bleeding plug
A	ON (Open)
B	OFF (Close)

4. Loosen the air-bleeding plug of the injection pump.

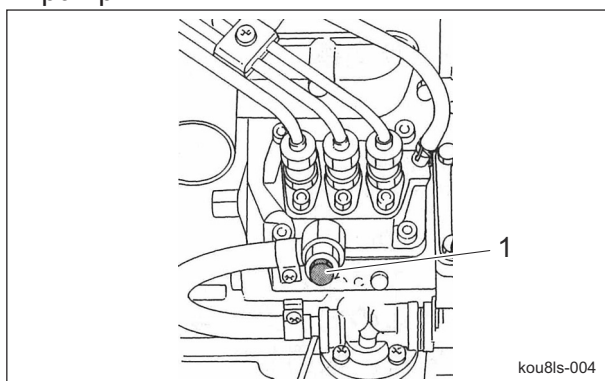

Air Bleeding of Fuel System_002

1	Air-bleeding plug
---	-------------------

5. Sit on the operator's seat.
6. Make sure that the parking brake is applied.
7. Set the reel rotation switch to the "STOP" position.
8. Make sure that the traveling pedal is in the neutral position.
9. Set the ignition key to the "START" position.

Important

In the case that there are still air bubbles in the fuel from air-bleeding plug even after 15 seconds or more passed after setting the ignition key to "START", pause for 30 seconds or more and then repeat the same procedure.

10. If the starter rotates and air bubble of the fuel from the air-bleeding plug has gone, return the ignition key slowly to "OFF" position and tighten the plug.

Inspection of Fuel Filter

1. Make sure that there is no fuel leakage.
2. Make sure that the filter is not damaged.
3. Make sure that the filter is not contaminated.

Inspection of Coolant

Caution

Do not touch the radiator or coolant during engine operation or right after the engine has been turned off. Otherwise, you may get burned due to high temperatures.

Caution

Inspection should take place after the engine has well cooled down.

Make sure that the coolant level in the reserve tank is between "FULL" and "LOW." When the coolant level is lower than the "LOW" mark, fill the tank with clean water and antifreeze.

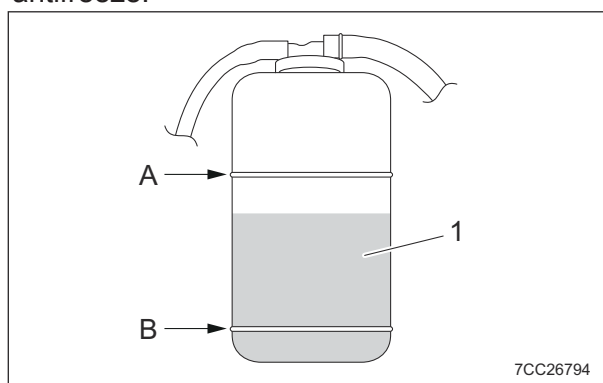

Inspection of Coolant_001

1	Reserve tank
2	FULL
3	LOW

Handling Instructions

Inspection of Air Cleaner

1. Make sure that there is no damage to the air cleaner.
2. Make sure that the air cleaner filter is not contaminated.

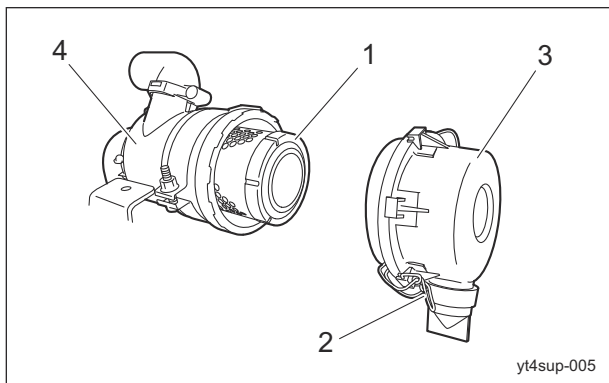

Inspection of Air Cleaner_001

1	Air cleaner filter
2	Clip
3	Air cleaner cap
4	Air cleaner body

Inspection of Radiator Cover

1. Make sure that there is no damage to the radiator cover.
2. Make sure that the radiator cover is not contaminated.

Inspection of Dust-Proof Mesh

1. Make sure that there is no damage to the dust-proof mesh.
2. Make sure that the dust-proof mesh is not contaminated.

Inspection of Radiator

1. Make sure that there is no damage to the radiator.
2. Make sure that the radiator is not contaminated.

Inspection of Engine-Associated Parts

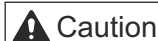

Caution
Perform operations after the muffler, engine and other parts have sufficiently cooled. Otherwise, you may get burned.

1. Check for damages and dirt.
2. Check the mount for looseness and cracks.
3. Check for liquid leakage.

4. Check on and around the muffler for grass clippings and flammable materials.

Main Vehicle

Inspection of Hydraulic Oil

The oil gauge is on the side of the hydraulic tank.

1. Lower the mower units and maintain that position on a level surface.
2. Make sure that the oil level is at the middle of the oil gauge.

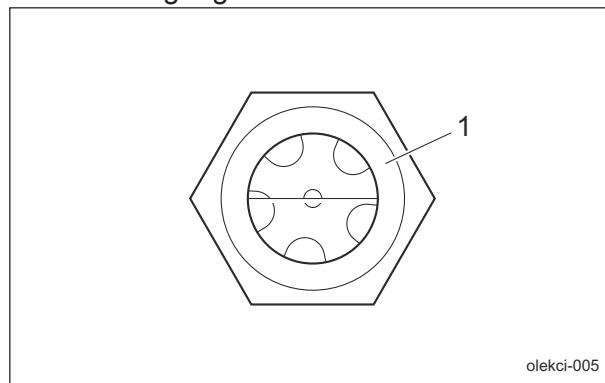

Inspection of Hydraulic Oil_001

1	Oil gauge
---	-----------

3. Check underneath the machine for oil leakage.

Inspection of Tires

1. Check the pneumatic pressure of the tires.
 2. Make sure that there are no cracks, damage or abnormal wear.
- (For green/For field)

	Tire size	Pneumatic pressure
Front wheel	Smooth 18 × 9.50-8 2P	80 kPa (0.8 kgf/cm ²)
Rear wheel	Smooth 18 × 9.50-8 2P	80 kPa (0.8 kgf/cm ²)

(For teeing ground)

	Tire size	Pneumatic pressure
Front wheel	Pillow Dia 18 × 8.50-8 4P	100 kPa (1.0 kgf/cm ²)
Rear wheel	Pillow Dia 18 × 8.50-8 4P	100 kPa (1.0 kgf/cm ²)

Handling Instructions

Inspection of Battery

Danger

Keep away from fire while inspecting or charging the battery.
The battery may explode.

Caution

Implement after the engine and muffler etc. have well cooled down.
Otherwise, you may get burned.

Important

Be sure to stop the engine before inspecting or charging the battery.

Battery inspection items are described below.

1. Inspecting the exterior

Visually inspect the exterior of the battery, and check that there are no cracks, splits, missing sections, or abnormal deformation in the battery case, and that there is no electrolyte leaking.

If abnormalities are found, immediately replace the battery.

2. Cleaning the exterior

Warning

Do not clean the battery with a dry cloth. Cleaning the battery with a dry cloth may cause it to catch fire or explode due to static electricity.

Use a wet cloth for cleaning.

Inspect the vent plugs or vent holes on the side of the battery, and if they are blocked by dirt wash them with water to remove the blockage.

Continuing to use the battery with the vent holes blocked may cause the battery to rupture from increased internal pressure due to gases generated inside the battery.

3. Inspecting the mounting bracket

Inspect whether the battery is secured firmly with the mounting bracket.

If the bracket is loose, tighten the mounting bracket nuts until the battery is secured firmly.

An improperly mounted battery may cause damage to the battery case or electrolyte leaks due to the battery moving with vibrations while traveling.

4. Inspecting the cable terminals

If the connection between the battery terminals and vehicle's cable terminals are loose, tighten the nuts until the cable terminals are secured firmly.

Insufficiently tightened terminals may result in poor battery charging, damage to the terminals due to poor contacts, or an explosion.

If the terminals are corroded, rub them clean with a wire brush or fine grit sandpaper, and lightly apply anti-rust grease.

5. Inspecting the electrolyte level and refilling

Warning

Do not allow the battery fluid level to become lower than the LOWER LEVEL (minimum fluid level line).

The battery may explode if it is used or charged while the battery fluid level is at the LOWER LEVEL (minimum fluid level line).

Warning

When refilling, do not fill purified water above the UPPER LEVEL line.

Doing so may result in electrolyte leaks.

Clean the areas around the battery fluid level lines using a cloth dampened with water to check the electrolyte level from the side of the battery.

Make sure that the battery fluid level is between the UPPER LEVEL (maximum fluid level line) and the LOWER LEVEL (minimum fluid level line).

Refill with purified water up to the UPPER LEVEL line if the level is lower than halfway between the UPPER LEVEL and LOWER LEVEL lines.

Handling Instructions

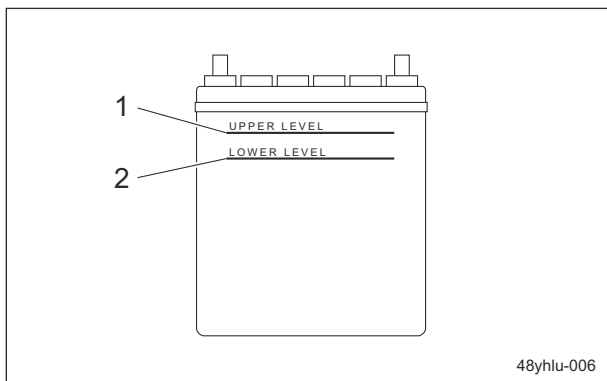

Inspection of Battery_001

1	UPPER LEVEL line
2	LOWER LEVEL line

Inspection of Covers

Warning

If you have removed the cover during inspection, make sure that you replace it in the original position securely. If the cover remains removed, the operator or the mechanic may come in contact with the rotating objects or belt, or foreign objects may fly off, possibly resulting in injuries.

1. Make sure that there is no wear or deterioration of covers.
2. Make sure that there is no damage to covers.
3. Make sure that there is no interference with moving parts due to deformation of covers.
4. Make sure that covers are installed in their appropriate positions.

Inspection of Wire

1. Make sure that the wire is not cracked or damaged.
2. Make sure that the wire is not worn.
3. Make sure that the wire is not crushed.
4. Make sure that the wire is not bent.
5. Make sure that the wire is not corroded or rusted.

Inspection of Traveling Pedal

1. Make sure that there is no play in the pedal.
2. Make sure that the pedal moves smoothly.
3. Make sure that there is no abnormal sound when the pedal is depressed.

Inspection of Brake Lever

1. Check the brake lever moves smoothly.
 - [1] Pull the brake lever.
 - [2] Press the push button and release the brake lever.
2. Check there is no abnormal sound when the brake lever is moved.
3. Check the brake is applied when you pull the brake lever.

Inspection of Steering Wheel

1. Make sure that there is no play in the steering wheel.
2. Make sure that the steering wheel turns smoothly when it is turned.
3. Make sure that there is no abnormal sound when the steering wheel is turned.
4. Check the direction of tires when the steering wheel is turned.
 - [1] Start the engine.
 - [2] Make sure that the rear tire turns left when the steering wheel is turned right.
 - [3] Make sure that the rear tire turns right when the steering wheel is turned left.
 - [4] Stop the engine.

Inspection of Liquid Leakage

Important

After approximately 50 hours of operation, some tightened portions may be loosened and liquid such as oil may leak. Be sure to retighten the parts.

Important

Repair the machine before operation if liquid leakage found. Ignoring leakage will cause further trouble.

1. Check the bottom of the machine for leakage of liquid such as oil, water, fuel, etc.
2. Locate the leakage and identify the type of liquid.

Inspection of Ball Proof Net

1. Check the ball proof net is not deteriorated.
2. Check there is no damage nor deformation of the ball proof net.

Handling Instructions

Inspection of Bolts and Nuts

Important

The bolts and nuts may be loosened at the earlier stage of the use.
Be sure to retighten or replace before operating the machine whenever there is any abnormality.

1. Check the bolts and nuts for looseness and coming off.
2. Check the bolts and nuts for cracks and damages.
3. Check the bolts and nuts for rust.
4. Check around the bolts and nuts for traces of rust fluid.
5. Check for unequal bolt length.
6. Check the bolts and nuts for stripped threads and abrasion.

Inspection of Hour Meter

1. Check the hour meter is not damaged.
2. Check the hour meter operates correctly.
 - [1] Switch the ignition key to the "ON" position.
 - [2] Check the displayed number increases correctly.
 - [3] Switch the ignition key to the "OFF" position.

Inspection of Water Temperature Gauge

1. Check the water temperature is not damaged.
2. Check the water temperature operates correctly.
 - [1] Switch the ignition key to the "ON" position.
 - [2] Check the water temperature needle swings.
 - [3] Switch the ignition key to the "OFF" position.

Inspection of Pilot Lamps

1. Check the pilot lamps are clean.
2. Check the pilot lamps are not damaged.

Inspection of Safety Device

Repair the machine before operation whenever there is any abnormality.

1. Interlock system
Make sure that the interlock system operates correctly.
"Interlock System" (Page 4-10)
2. ROPS
(If the machine is equipped with ROPS and a seat belt)
Make sure that the ROPS is not damaged or broken.
3. Seat belt
(If the machine is equipped with ROPS and a seat belt)
Make sure that the seat belt is not damaged or broken.

Inspection of Light

Note:

Depending on the specifications, this function may not be available.

1. Check the lights are not damaged.
2. Check the lights turn on/off.
 - [1] Switch the ignition key to the "ON" position.
 - [2] Set the light switch to the "ON" position.
 - [3] Check the lights have turned on.
 - [4] Set the light switch to the "OFF" position.
 - [5] Check the lights have turned off.
 - [6] Switch the ignition key to the "OFF" position.

Inspection of Grass Catcher

1. Make sure that there is no wear or deterioration of the grass catcher.
2. Make sure that there is no damage to the grass catcher.
3. Make sure that there is no interference to moving parts due to deformation of the grass catcher.

Handling Instructions

Mower Unit

Inspection of Reel Cutter (Cutting Cylinder) and Bed Knife (Bottom Blade)

 **Caution**

Wear gloves when touching edged tools to avoid cutting your hands.

1. Check to see whether or not the edge of the reel cutter (cutting cylinder) and the bed knife (bottom blade) are too blunt to cut.
2. Make sure that the reel cutter (cutting cylinder) and the bed knife (bottom blade) are not cracked.
3. Check to see how much the reel cutter (cutting cylinder) and the bed knife (bottom blade) are worn.
4. Make sure that the reel cutter (cutting cylinder) and the bed knife (bottom blade) have not changed color due to heat from grinding.
5. Check to see whether or not the second edge face (relief) remains at the point of reel cutter (cutting cylinder).
6. Make sure that the welding between the reel cutter (cutting cylinder) and the disc has not come off.

Inspection of Covers

 **Warning**

If you have removed the covers during inspection, be sure to securely install them in their original positions.
If a cover remains removed, the operator or the mechanic may come into contact with rotating parts or belts and foreign objects may fly off, possibly resulting in injuries.

1. Make sure that there is no wear or deterioration of the reel cover and all other covers.
2. Make sure that there is no damage to the reel cover and all other covers.
3. Make sure that there is no interference with moving parts due to deformation of the reel cover and all other covers.
4. Make sure that the reel cover and all other covers are installed in their appropriate positions.

Inspection of Rollers

1. Make sure that there is no abrasion nor adhesion of the roller.
2. Make sure that there is no wear of the roller shaft.
3. Make sure that there is no wear nor damage of the oil seal.
4. Make sure that there is no wear nor rust of the bearing.
5. Make sure that there is no play in the roller shaft.

Inspection of Groomer

Note:

Depending on the specifications, this function may not be available.

 **Caution**

Wear gloves when touching edged tools to avoid cutting your hands.

1. Make sure that the vertical blades are not cracked.
2. Check how much the vertical blades are worn.
3. Make sure that the shaft is not worn nor bent.
4. Make sure that there is no wear nor rust of the bearing.
5. Make sure that there is no play in the groomer shaft.

Inspection of Thatching Reel

Note:

Depending on the specifications, this function may not be available.

 **Caution**

Wear gloves when touching edged tools to avoid cutting your hands.

1. Make sure that the vertical blades are not cracked.
2. Check how much the vertical blades are worn.
3. Make sure that the shaft is not worn nor bent.
4. Make sure that there is no wear nor rust of the bearing.

Handling Instructions

5. Make sure that there is no play in the thatching reel shaft.

Inspection of Thatching Brush

Note:

Depending on the specifications, this function may not be available.

1. Make sure that there is no abrasion nor adhesion of the brush.
2. Make sure that there is no wear of the brush shaft.
3. Make sure that there is no abnormality in the brush.
4. Make sure that there is no wear nor rust of the bearings.
5. Make sure that there is no play in the brush shaft.

Inspection of CR Brush

Note:

Depending on the specifications, this function may not be available.

1. Make sure that there is no abrasion nor adhesion of the brush.
2. Make sure that there is no wear of the brush shaft.
3. Make sure that there is no abnormality in the brush.
4. Make sure that there is no play in the fit of the bearing and the housing.
5. Make sure that there is no play in the brush shaft.

Inspection of Front Scraper

Note:

Depending on the specifications, this function may not be available.

1. Make sure that there is no damage nor deformation of the scraper.
2. Make sure that there is no contact between the scraper and roller.

Inspection of Rear Scraper (Wire Type)

Note:

Depending on the specifications, this function may not be available.

1. Make sure that there are no breaks or sagging in the scraper (wire).
2. Make sure that there is no contact between the scraper and roller.

Adjustment before Work

Main Vehicle

Adjustment of Seat Position

Use the seat adjustment levers to adjust the seat position.

Adjust the position to fit the operator.

Important

After adjustment of the seat, make sure that the backrest does not interfere with the hood with the operator seated.

1. Use the forward/backward adjustment lever to adjust the seat back and forth.
2. Use the backrest tilt adjustment lever to adjust the angle of the backrest.
3. Pull out the suspension adjustment handle and move it up or down to adjust the firmness of the seat suspension. Observe the suspension adjustment scale while making adjustments. [50 - 160 kg (110.2 – 352.7 lb)]
4. The seat can be adjusted to one of three levels by pulling up the forward tilt angle adjustment lever.

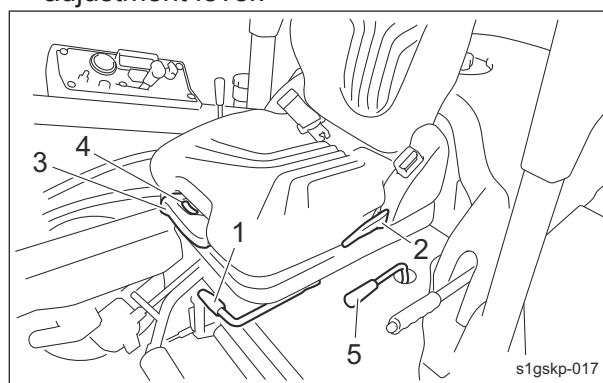

Adjustment of Seat Position_001

1	Forward/backward adjustment lever
2	Angle adjustment lever
3	Suspension adjustment handle
4	Suspension adjustment scale
5	Forward tilt angle adjustment lever

Handling Instructions

Adjustment of Armrest Position

Note:

Depending on the specifications, this function may not be available.

The armrest angle can be adjusted by turning the armrest adjustment knob.

Adjust it to fit the operator.

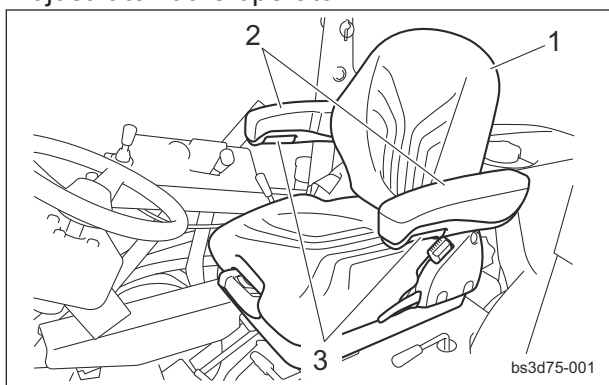

Adjustment of Armrest Position_001

1	Seat
2	Armrest
3	Armrest adjustment knob

Adjustment of Steering Wheel Position

Warning

Since it is dangerous, do not adjust the steering wheel while traveling.

Caution

Be sure the steering wheel position is securely locked.

It may result in an unexpected accident if it becomes loose while traveling.

Caution

When operating the height adjustment lever, be careful not to pinch your hands.

The steering wheel arm can be adjusted up or down.

Adjust the position according to the operator's body size.

Pull up the height adjustment lever, position the steering wheel arm to a proper position for your work and push down the height adjustment lever to lock it.

The height adjustment lever is attached to the right of the seat.

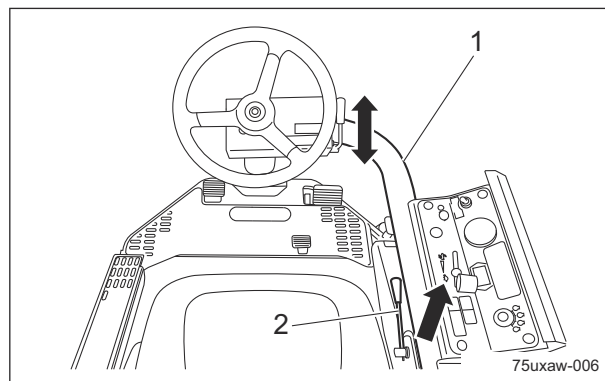

Adjustment of Steering Wheel Position_001

1	Steering wheel arm
2	Height adjustment lever

The steering wheel angle can be adjusted up or down.

Adjust the position according to the operator's body size.

Pull the angle adjustment lever, position the steering wheel to a proper position for your work and push the angle adjustment lever forward to lock it.

The angle adjustment lever is attached to the right of the steering wheel.

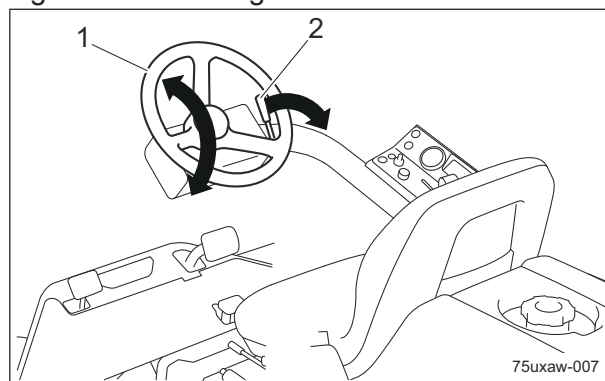

Adjustment of Steering Wheel Position_002

1	Steering wheel
2	Angle adjustment lever

Handling Instructions

Mounting and Dismounting

Procedure to Mount/Dismount

This machine is equipped with a step for mounting/dismounting.
Place your foot on the step when mounting and dismounting the machine.

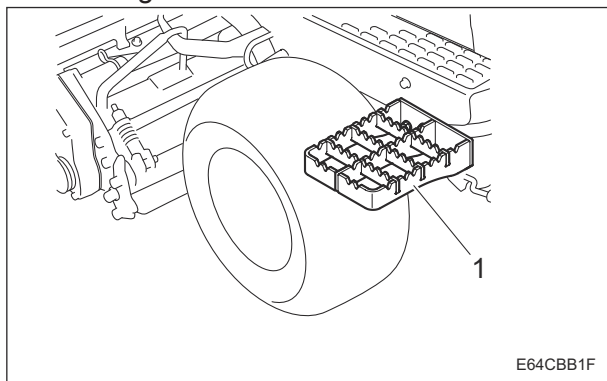

Procedure to Mount/Dismount_001

1	Step
---	------

Start/Stop of Engine

Procedure to Start Engine

Caution

Before starting the engine, make sure that there are no people or obstacles around the machine.

Important

Starter operation must take 15 seconds or less.
When the engine does not start, stop using the battery for 30 to 60 seconds to avoid exhausting the battery.

1. Make sure that the fuel cock is open.

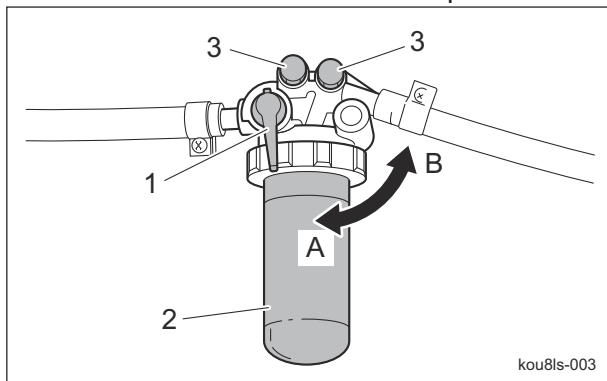

Procedure to Start Engine_001

1	Fuel cock
2	Fuel filter
3	Air-bleed plug
A	ON (open)
B	OFF (close)

- Sit on the seat.
- Make sure that the parking brake is applied.
- Set the reel rotation switch to the "Stop" position.
- Make sure that the traveling pedal is in the neutral position.
- Shift the throttle lever halfway from the "Low speed" to the "High speed" position.

Important

The thermo-start lamp turns off at the specified time. However, the lamp turning off is not related to the glow plug generating heat. When the ignition key is left in the "GLOW" position after the lamp is turned off, the plug will still generate heat. The lamp will stay illuminated for 5 seconds.

7. Switch the ignition key to the "GLOW" position.

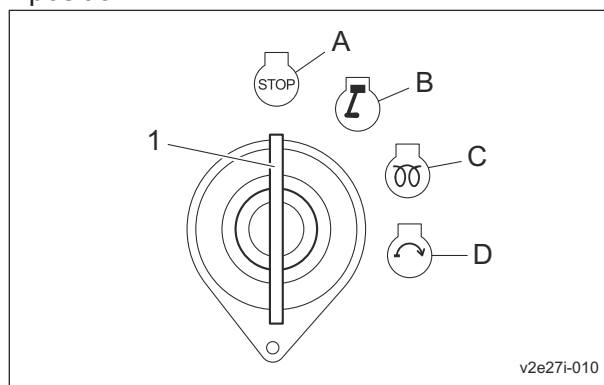

Procedure to Start Engine_002

1	Ignition key
A	OFF
B	ON
C	GLOW
D	START

Handling Instructions

8. Make sure that the thermo-start lamp is turned on.

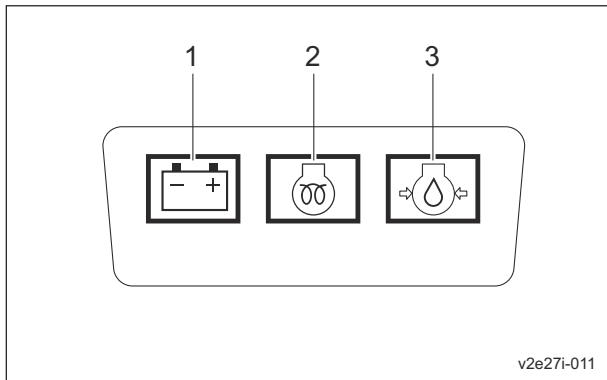

Procedure to Start Engine_003

1	Charge lamp
2	Thermo-start lamp
3	Oil pressure lamp

Important

Quickly returning the ignition key from the "START" position to the "ON" position may damage the machine.

9. After the thermo-start lamp turned off, immediately set the ignition key to the "START" position.
10. When the starter starts rotating and the engine starts, slowly return the ignition key to the "ON" position.
11. Check that the charge lamp and the engine oil pressure lamp turn off. When they do not turn off, stop the engine and inspect the machine.

Important

The machine may not be able to deliver essential performance without warm-up. Moreover, the equipment may be damaged.

12. Shift the throttle lever to the "Low" position to warm up the engine.
Warming-up time differs depending on the outside temperature.
Approximate warming-up time

- [1] When the outside temperature is less than 10 °C (50 °F)
- Shift the throttle lever to "Low", and then warm up the engine for 10 minutes.
 - Then, shift the throttle lever to "High", and warm up the engine for additional 5 minutes.

- [2] When the outside temperature is more than 10 °C (50 °F) and less than 20 °C (68 °F).

- Shift the throttle lever to "Low", and then warm up the engine for 5 minutes.
- Then, shift the throttle lever to "High", and warm up the engine for additional 3 minutes.

- [3] When the outside temperature is more than 20 °C (68 °F)

- Shift the throttle lever to "Low" and then warm up the engine for 5 minutes, or warm up the engine until the needle points above "C" on the water temperature gauge.

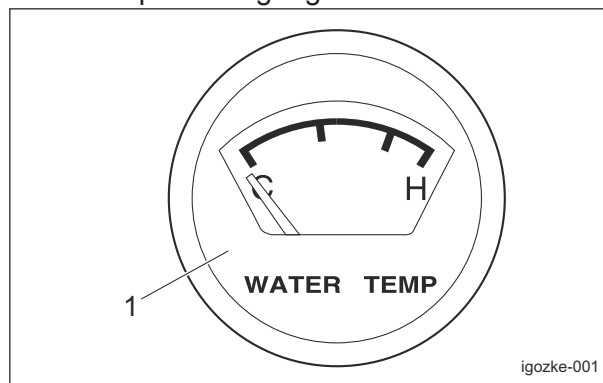

Procedure to Start Engine_004

1	Water temperature gauge
---	-------------------------

Procedure to Stop Engine

- Set the traveling pedal to the neutral position.
- Apply the parking brake.
- Set the reel rotation switch to the "Stop" position.
- Shift the throttle lever to the "Low speed" position, and warm up the engine for 1-2 minutes.
- Lower all the mower units completely.
- Switch the ignition key to the "OFF" position.
- Check the engine has stopped.

Parking and Stopping

Procedure to Leave The Machine

⚠ Caution

If the brakes are not sufficiently effective, use the wheel stoppers to secure the machine.

⚠ Caution

Never park the machine on a slope.

1. Park the machine on level ground.
2. Apply the parking brake.
3. Stop the engine.
4. Remove the ignition key.
5. Step off the machine.

Move

Traveling Procedure

⚠ Warning

Set the reel rotation switch to the "Stop" position except during mowing or backlapping and using reel excess discharge system.

⚠ Caution

Under any circumstances drive the machine at such a speed that you can stop it immediately for emergencies.

⚠ Caution

In case of 2WD/3WD model, travel in 2WD mode since it is dangerous to travel on steep downward slopes, wet road surface or downward slopes of wet lawn in 3WD mode. Rear tire going into a skid may cause loss of traveling control.

Important

In case of 2WD/3WD model, whenever the reel rotation switch is set to the "Rotation" position, the drive mode is put into 3WD regardless of the position of the 2WD/3WD selector switch.

Important

Do NOT start to move or stop the machine abruptly. It will damage the hydraulic system or result in oil leakage.

1. Start the engine.
"Procedure to Start Engine" (Page 5-13)
2. Raise all mower units.
3. Gradually move the throttle lever to the "High speed" position.
4. While pressing the push button, release the parking brake lever.
5. Slowly depress the traveling pedal.
6. The machine starts traveling.
7. The machine stops slowly when the traveling pedal released.

Handling Instructions

Cutting Work

Cutting Procedure

Warning

Set the reel rotation switch to the "Stop" position except during mowing or backlapping and using reel excess discharge system.

Caution

In case of 2WD/3WD model, travel in 2WD mode since it is dangerous to travel on steep downward slopes, wet road surface or downward slopes of wet lawn in 3WD mode. Rear tire going into a skid may cause loss of traveling control.

Caution

Be sure to install the grass catchers. Otherwise, thrown objects from the mower units may hit your feet.

Important

In case of 2WD/3WD model, whenever the reel rotation switch is set to the "Rotation" position, the drive mode is put into 3WD regardless of the position of the 2WD/3WD selector switch.

Important

Do NOT start to move or stop the machine abruptly. It will damage the hydraulic system or result in oil leakage.

1. Install the grass catchers.
2. Set all reel reverse levers to the "Normal rotation" position.
3. Start the engine.
"Procedure to Start Engine" (Page 5-13)
4. Raise all mower units.
5. Shift the throttle lever to the "High speed" position to run the engine at the maximum speed.
6. While pressing the push button, release the parking brake lever.
7. Set the reel rotation switch to the "Rotation" position.

8. Start the work following the procedure below.

[1] Depress the traveling pedal.

[2] Lower the mower units when the mower unit reaches the collar of the green.

At the same time, the reel cutters (cutting cylinders) start rotating.

Note:

During the work, the reel cutters (cutting cylinders) will rotate or stop in sync with the up and down motion of the mower units.

9. Set the reel rotation switch to the "Stop" position after the operation completed.

Handling Instructions

Reel Excess Discharge System

Warning

The reel cutter rotates while holding down the up switch when the reel rotation switch is set to the "Rotation" position.

Set the reel rotation switch to the "Stop" position except during mowing or backlapping and using reel excess discharge system.

Warning

The reel cutter rotates when using reel excess discharge system.

Keep hands and feet away from moving parts.

Caution

Before using reel excess discharge system, make sure that there are no people around the machine.

Important

Do not press the up switch when the mower unit is at lowered position.

Otherwise, the harness will get damaged.

Important

The reel cutter keeps rotating even if the mower unit raised to the highest position while holding down the up-switch.

- Preventing lumps of clippings from falling onto the green.
Use reel excess discharge system so that the clippings inside the reel cutter can be removed during mowing operation or when discarding clippings.
 1. Stop the engine.
 2. Brush the clippings accumulated on the bracket.
At the time the clippings comes inside of the reel cutter.
 3. Install the grass catchers.
 4. Sit on the seat.
 5. Start the engine.
 6. Raise all mower units.
 7. Set the throttle lever to the "High Speed" position.

8. Set the reel rotation switch to the "Rotation" position.
9. Hold down the up switch for about a second.
While holding down the up switch, the reel cutter rotates while the mower unit rising and the clippings inside the reel cutter are removed.
10. Set the reel rotation switch to the "Stop" position after the operation completed.
11. Stop the engine.
- Vehicle wash
When washing the vehicle after mowing operation, the clippings can be removed with the reel excess discharge system.
 1. Stop the engine.
 2. Set the transmission shift lever to the "LAP" position.
 3. Sit on the seat.
 4. Start the engine.
 5. Raise all mower units.
 6. Set the throttle lever to the "High Speed" position.
 7. Set the reel rotation switch to the "Rotation" position.
 8. Stand on the right side of the machine and hold down the up switch for about 2 to 3 seconds.
While holding down the up switch, the reel cutter rotates while the mower unit rising and the clippings inside the reel cutter are removed.
 9. Set the reel rotation switch to the "Stop" position after the operation completed.
 10. Stop the engine.

Removing Grass Catcher

1. Set the reel rotation switch to the "Stop" position.
2. Lower the mower unit.
3. Apply the parking brake.
4. Stop the engine.

Handling Instructions

5. Lift up the grass catcher and remove it.

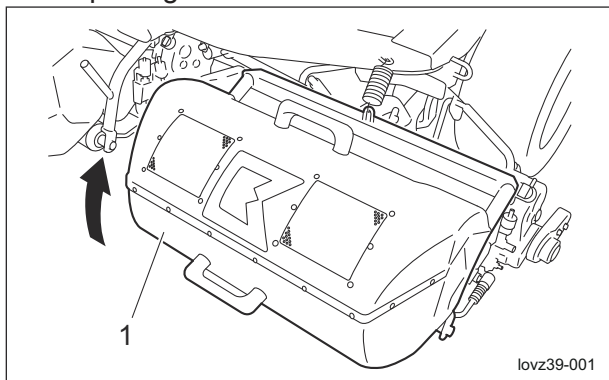

Removing Grass Catcher_001

1	Grass catcher
---	---------------

1. Pull up the dust-proof mesh.

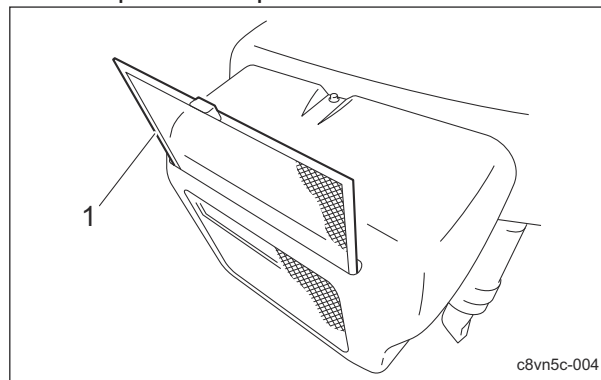

Cleaning of Dust-Proof Mesh_001

1	Dust-proof mesh
---	-----------------

Transporting

Transporting Procedure

When loading the machine into a trailer or a truck to transport it, drive the machine forward. When unloading, drive the machine in reverse.

Cleaning after Use

The purpose of the machine cleaning is to:

- Prevent accidents
- Prevent damage to the machine
- Maintain machine performance

Properly clean the machine to maintain its functionality and performance.

If you detect any abnormalities with the machine, immediately perform maintenance or repairs.

Engine

Cleaning of Dust-Proof Mesh

Important

An unclean dust-proof mesh may cause overheating or damage to the engine. It may also cause malfunction of the hydraulic system.

If the dust-proof mesh has been contaminated with dust, be sure to clean it.

Especially, after operating the machine in a dusty environment, it is important to remove dust as soon as possible.

2. Carefully clean the front and back of the dust-proof mesh with water or compressed air.

Cleaning of Radiator

Important

An unclean radiator cover may cause overheating or damage to the engine. It may also cause malfunction of the hydraulic system.

Important

Do not use solid objects, such as a spatula or screwdriver, or high-pressure water to clean the radiator or oil cooler. Otherwise, special fins or tubes may be damaged, possibly resulting in reduced cooling performance or coolant leakage.

If the radiator has been contaminated with dust, be sure to clean it. Especially, after operating the machine in a dusty environment, it is important to remove dust as soon as possible.

1. Remove the bolt.
2. Open the radiator cover.

Handling Instructions

- Pull up the dust-proof mesh upward and remove it.

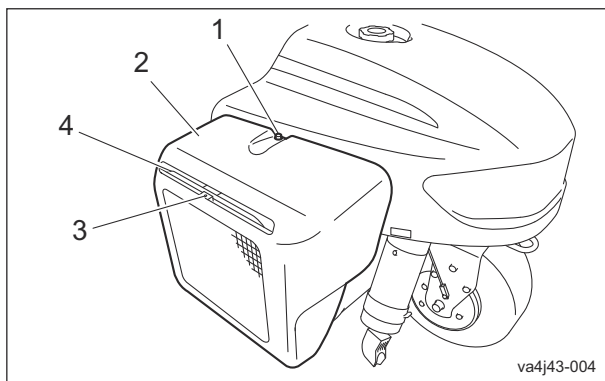

Cleaning of Radiator_001

1	Bolt
2	Radiator cover
3	Dust-proof mesh
4	Radiator

- Carefully clean the front and back of the radiator with water or compressed air.

Cleaning of Engine-Associated Parts

Caution

Perform operations after the muffler, engine and other parts have sufficiently cooled. Otherwise, you may get burned.

- Clean clippings and remove dirt.
- Blow compressed air to clean any grass or flammable materials that may be attached on or around the muffler.

Mower Unit

Cleaning of Mower Unit

Important

While cleaning, do not allow water on the sealed parts of the reel shaft. (Avoid high-pressure water cleaning.) Otherwise, it may cause damage to the machine.

- Be sure to clean the mower unit after use.
- Stop the engine.
 - Carefully clean the front and back of the mower unit with water or compressed air.
 - Remove any grass wrapped around the reel cutter (cutting cylinder).

Storage

Short-Term Storage

Short-term storage means that the machine is temporarily stored (within 1 month) without use.

Follow the instructions below for short-term storage of the machine.

- Cleaning
 - Remove dirt, grass clippings, oil stains etc. completely from the main vehicle and engine.
- Mower units
 - When storing this machine, lower all the mower units unless a positive mechanical lock is provided.
- Storage location
 - Cover the machine and store it in a dry place where it will not be exposed to rain.

Handling Instructions

Precautions for Maintenance	Page 6-2
Operations before Maintenance	Page 6-2
Procedure to Remove/Install Mower Unit	Page 6-2
Jacking Up The Machine	Page 6-3
About Jacking Up The Machine	Page 6-3
Jack-Up Points	Page 6-3
Inspection and Cleaning	Page 6-4
Engine	Page 6-4
Main Vehicle	Page 6-6
Mower Unit	Page 6-7
Supplying Fluids	Page 6-7
Engine	Page 6-7
Main Vehicle	Page 6-9
Greasing	Page 6-12
About Greasing	Page 6-12
Greasing Points	Page 6-12
Lubrication	Page 6-17
About Lubrication	Page 6-17
Lubricating Points	Page 6-17
Adjustment	Page 6-18
Engine	Page 6-18
Main Vehicle	Page 6-19
Mower Unit	Page 6-21
Replacement	Page 6-36
Engine	Page 6-36
Main Vehicle	Page 6-40
Mower Unit	Page 6-46
Storage	Page 6-48
Long-Term Storage	Page 6-48

Maintenance

Precautions for Maintenance

Warning

The chapter "Maintenance" in this manual describes practical measures which should be performed by a mechanic with expertise. The owner should instruct the mechanic with expertise to perform maintenance service for this machine.

Caution

First, learn well the operations you plan to perform.

Important

Use tools appropriate for each operation.

Important

Use Baronesse genuine parts for replacement and accessories.
Our product warranty may be void if you use non-genuine parts for replacement or accessories.

1	Flexible wire
2	Lock nut
3	Bolt
4	Clip

[4] Slide the stopper of the mower attaching pipe forward and pull it out.

[5] Pull out the mower unit and remove it.

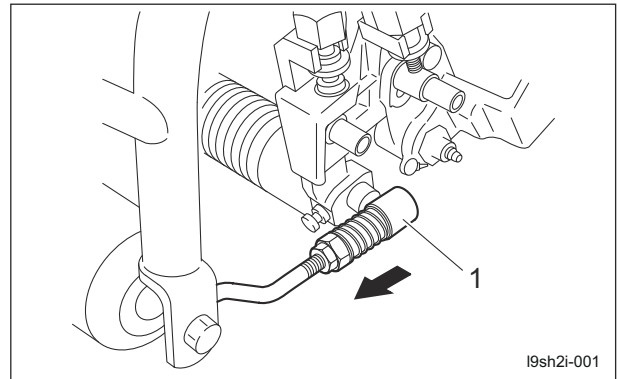

Procedure to Remove/Install Mower Unit_002

1	Stopper (left/right)
---	----------------------

2. Installing the mower unit
For installing the mower unit, reverse the removing procedure.

Operations before Maintenance

Procedure to Remove/Install Mower Unit

1. Removing the mower unit
 - [1] Loosen the lock nut.
 - [2] Loosen the bolt.
 - [3] Remove the clip which fixes the mower unit and the flexible wire.

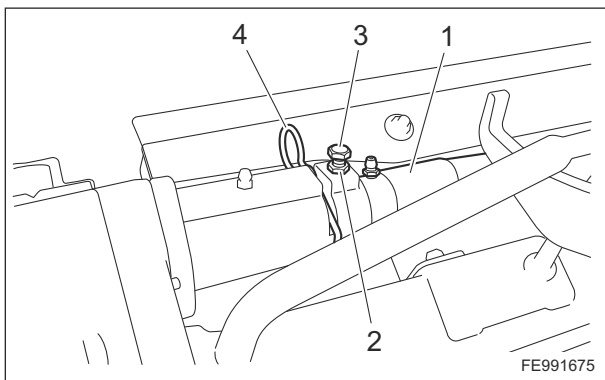

Procedure to Remove/Install Mower Unit_001

Jacking Up The Machine

About Jacking Up The Machine

⚠ Warning

When replacing a tire or beginning any other maintenance or repairs, be sure to chock the wheels to prevent the machine from moving. Before jacking up the machine, park it on a hard, flat surface such as a concrete floor and remove any obstacles that could prevent you from performing the work safely.

When necessary, use an appropriate chain block, hoist, or jack.

Support the machine securely with jack stands or appropriate blocks.

Failure to do so may cause the machine to move or fall, resulting in injury or death.

Important

Only place a jack under the jack-up points specified.

Placing a jack at any other point will result in damage to the frame or other parts.

Use the jack-up points identified in this manual when jacking up the machine.

Jack-Up Points

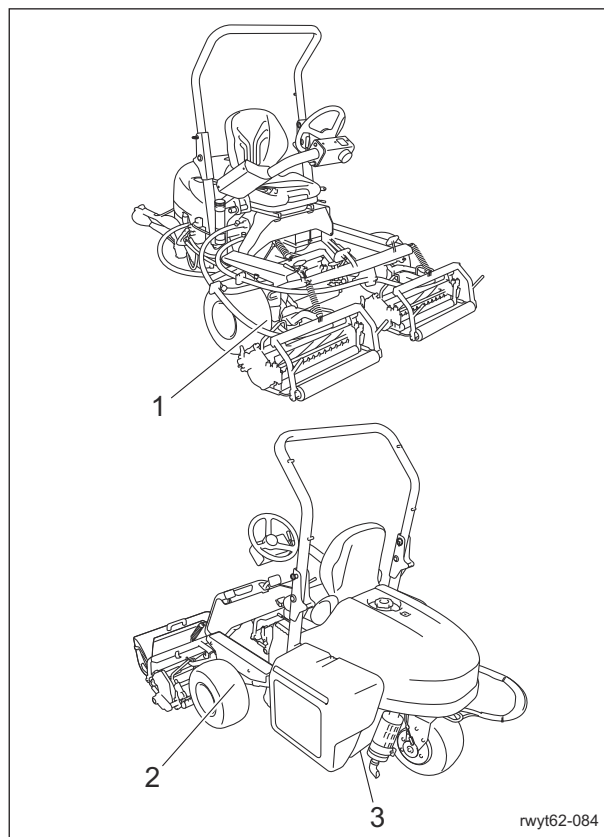

Jack-Up Points_001

1	Front right frame
2	Front left frame
3	Engine mount frame

1. Front right frame

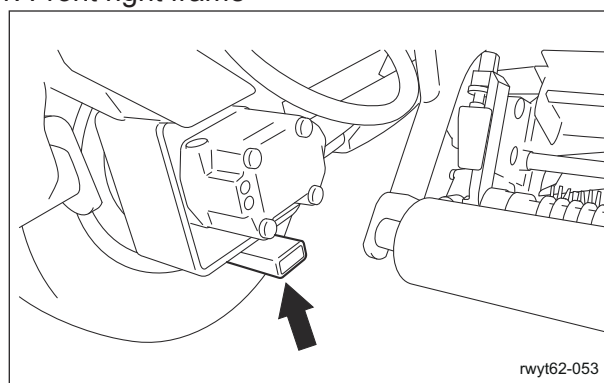

Jack-Up Points_002

Maintenance

2. Front left frame

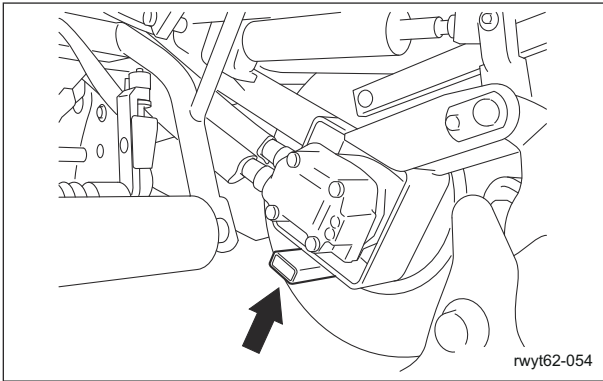

Jack-Up Points_003

3. Engine mount frame

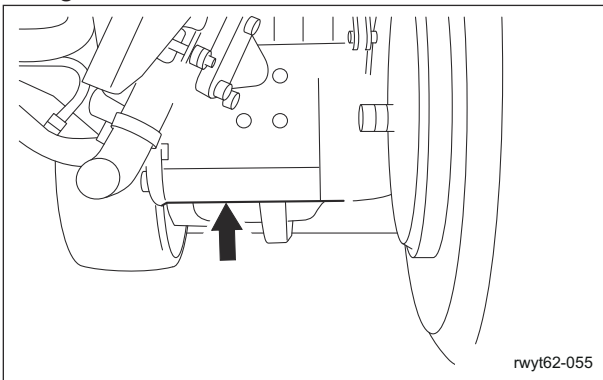

Jack-Up Points_004

4. Open the evacuator valve and remove dust and dirt according to the maintenance schedule.
5. Attach the air cleaner filter to the air cleaner body.
6. Install the air cleaner cap, and then fix it securely with the clips.

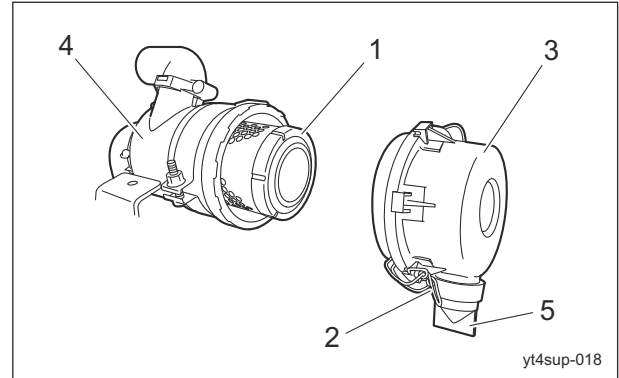

Cleaning of Air Cleaner Element_001

1	Air cleaner filter
2	Clip
3	Air cleaner cap
4	Air cleaner body
5	Evacuator valve

Inspection and Cleaning

Inspect and clean the machine with the goals of the followings.

- Accident prevention
- Failure prevention
- Performance retention

Make efforts for early detection of the machine failure and prevention of the sudden occurrence of trouble.

Perform maintenance and repair works immediately if any abnormality is found in the machine.

Engine

Cleaning of Air Cleaner Element

1. Remove the clips from the two locations and remove the air cleaner cap.
2. Remove the air cleaner filter.
3. While paying close attention not to damage the air cleaner filter, tap a solid portion of the air cleaner filter or blow compressed air from its inside to remove dust and dirt. If it is dirty, replace with a new air cleaner filter.

Cleaning of Fuel Filter

1. Close the fuel cock on fuel filter.

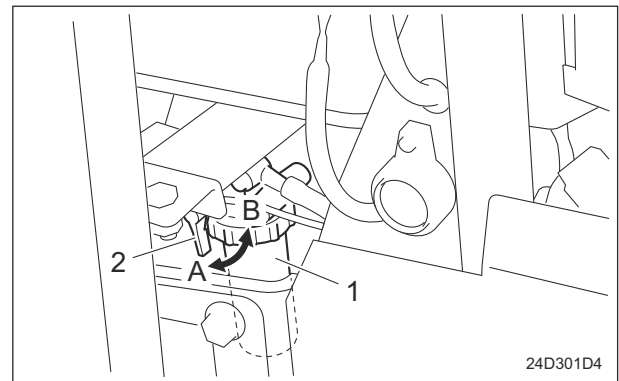

Cleaning of Fuel Filter_001

1	Fuel filter
2	Fuel cock
A	ON (Open)
B	OFF (Close)

2. Remove the retaining ring and then remove the cup.

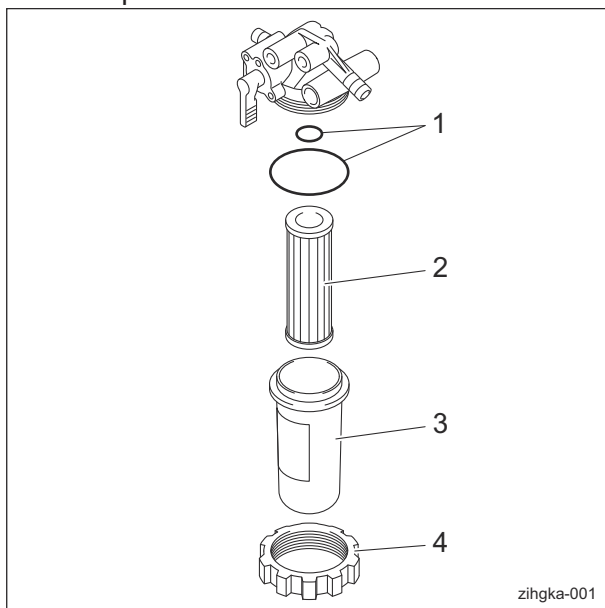

Cleaning of Fuel Filter_002

1	O-ring
2	Element
3	Cup
4	Retaining ring

3. Soak the filter element in diesel fuel and clean it.
4. Clean the inside of the filter cup with diesel fuel.

Important

While installing, be careful that it is not contaminated with dirt or dust. If the fuel is contaminated with dirt or dust etc., the fuel injection pump and injection nozzle will become worn.

5. Install the fuel filter and put the parts back together.

6. Fill up the fuel tank with fuel and open the fuel cock.

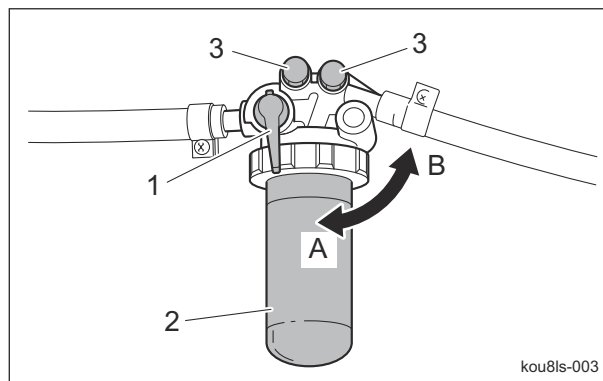

Cleaning of Fuel Filter_003

1	Fuel cock
2	Fuel filter
3	Air-bleeding plug
A	ON (Open)
B	OFF (Close)

7. Turn the key switch to the "ON" position. When the fuel pump is activated, the cup will be filled with fuel and air bleeding will occur automatically.
8. Switch the ignition key to the "START" position and remove air out of the fuel line.
9. If the engine does not start within 15 seconds after switching the ignition key to the "START" position, wait at least 30 seconds, and then repeat the same operation.

Inspection of Belt

Warning

The engine must be stopped when the belt is inspected.

Important

A slacking or damaged belt or damaged fan may cause overheating or lack of a battery charge.

1. Check the belt tension.
2. Make sure that there are no cracks and damage on the belt.
3. Make sure that there is no abnormal wear on the belt.

Maintenance

Main Vehicle

Inspection of Hydraulic Hoses and Pipes

Warning

When checking the hydraulic circuit for pinhole leaks or oil leakage from nozzles, do not use your hands. Use items such as paper or corrugated cardboard to find leakage points.

Be extremely careful with high-pressure oil as it may pierce your skin, resulting in personal accidents.

If fluid is injected into the skin it must be surgically removed within a few hours by a doctor familiar with this form of injury or gangrene may result.

1. Make sure that there is no wear, deterioration or damage in the hydraulic hoses and pipes.
2. Make sure that there is no looseness in the connecting portion of the hydraulic hoses and pipes.
3. Check underneath the machine for hydraulic oil leakage.

Inspection of Belts

Warning

Be sure to stop the engine before inspecting the belts.

Warning

If you have removed any covers, etc., during inspection, make sure that you securely re-attach them in their original positions.

If covers, etc., remain removed, the operator or the mechanic may come into contact with rotating parts or belts, and foreign objects may fly off, possibly resulting in injuries.

1. Press the middle of the belt with your finger to check the belt tension.
2. Make sure that there are no cracks, damage or abnormal wear.

Inspection of Electrical Wiring

Important

Electrical short circuit will cause fire, electrical leakage and malfunction of electrical equipments.

1. Make sure that there is no defacement in wires and terminals.
2. Make sure that there is no deterioration or damage in wires and terminals.
3. Make sure that there is no looseness in wiring connections.
4. Make sure that there is no poor terminal connection.

Inspection of Wheel Mounting Bolt

Important

Tighten the wheel mounting bolts on the specified torque by using a torque wrench.

1. Check the wheel mounting bolts and wheel nuts for looseness and coming off.
2. Check the wheel mounting bolts and wheel nuts for cracks and damages.
3. Check the wheel mounting bolts and wheel nuts for rust.
4. Check around the wheel mounting bolts and wheel nuts for traces of rust fluid.
5. Check the wheel mounting bolts for unequal bolt length.
6. Check the wheel mounting bolts and wheel nuts for stripped threads and abrasion.

Mower Unit

Inspection of Belts

Warning

Be sure to stop the engine before inspecting the belts.

Warning

If you have removed any covers, etc., during inspection, make sure that you securely re-attach them in their original positions. If covers, etc., remain removed, the operator or the mechanic may come into contact with rotating parts or belts, and foreign objects may fly off, possibly resulting in injuries.

1. Press the middle of the belt with your finger to check the belt tension.
2. Make sure that there are no cracks, damage or abnormal wear.

Cleaning Inside of Belt Cover

Note:

Depending on the specifications, this function may not be available.

Important

Clippings and dust etc. may come inside the belt cover and accumulate. Clean inside the cover in accordance with the Maintenance Schedule.

1. Remove the bolts.
2. Remove the belt cover.
3. Clean inside the cover with compressed air to remove the accumulated clippings and dust etc.
4. Install the belt cover.

5. Install the bolts.

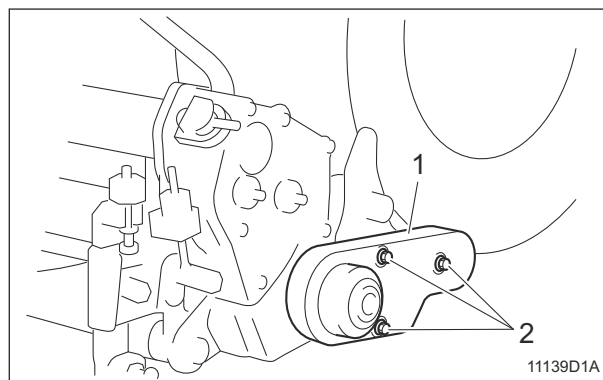

Cleaning Inside of Belt Cover_001

1	Belt cover
2	Bolt

Supplying Fluids

Engine

Supply of Engine Oil

For details on handling the engine, please refer to the separate Engine Handling Manual.

Important

Do not supply too much engine oil. Otherwise, the engine may be damaged.

Important

Do not mix different types of engine oil.

Important

Be sure to use engine oil that is classified as API Service Grade CF or higher, with an SAE Viscosity that is appropriate for the operating environment (ambient temperature).

Important

Securely install the oil level gauge and oil filler cap.

If the engine oil level is lower than the lower limit line on the oil level gauge, supply engine oil.

Supply engine oil through the oil filler port.

1. Place the machine so that the engine is level.
2. Stop the engine.
3. Open the hood.

Maintenance

4. Remove the oil filler cap.

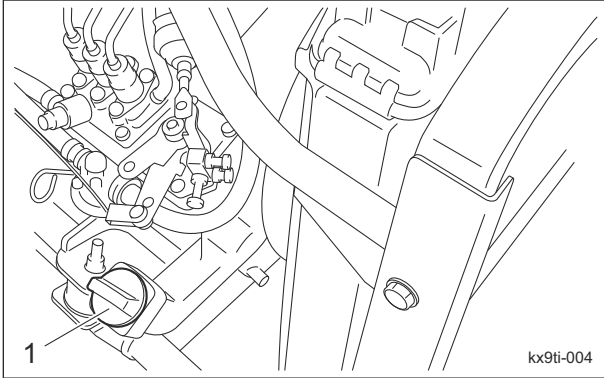

1 Oil filler cap

5. Supply new engine oil through the oil filler port.
Supply oil until it reaches a level in between the upper and lower limit lines on the oil level gauge.
6. Install the oil filler cap.
7. It will take a while for the supplied engine oil to descend into the oil pan.
Check the oil level again 10 to 20 minutes after filling the oil.
If the engine oil level is low, supply oil until it reaches the specified level.
8. Close the hood.

Supply of Coolant

Caution

Do not touch the radiator or coolant during engine operation or right after the engine has been turned off. Otherwise, you may get burned due to high temperatures. After the radiator has well cooled down, open the radiator cap.

Caution

Supply coolant after the engine has well cooled down.

Caution

The radiator cap is pressurized. If you remove the radiator cap while the engine is overheated, hot steam will burst out, possibly resulting in burns. Make sure that the water temperature and pressure are reduced, and then grab the cap with a thick cloth and gradually open the cap.

Important

When you supply coolant, be sure to mix clean water and antifreeze (long-life coolant), and then pour it into the radiator and reserve tank.

Important

Tightly close the radiator cap. If the cap is loose or incorrectly installed, water will leak and the engine will be damaged due to overheating.

When mixing antifreeze and clean water, refer to "Relationship between concentration of long-life coolant (LLC) and freezing temperature" below for the mixing ratio. Relationship between concentration of long-life coolant (LLC) and freezing temperature

Freezing temperature	LLC concentration (volume %)
Down to -10 °C (14 °F)	20 %
Down to -15 °C (5 °F)	30 %
Down to -20 °C (-4 °F)	35 %
Down to -25 °C (-13 °F)	40 %

If the coolant level in the reserve tank is low, supply clean water and antifreeze.

1. If the coolant level in the reserve tank is lower than the "LOW" mark, follow the steps below to fill the tank.
 - [1] Remove the reserve tank cap.
 - [2] Supply clean water and antifreeze up to the "FULL" mark in the reserve tank.
 - [3] Install the reserve tank cap

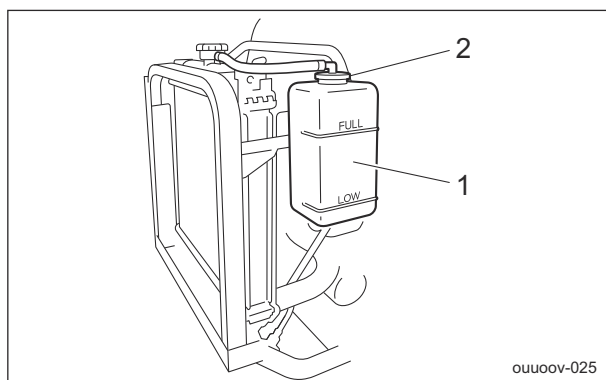

Supply of Coolant_001

1	Reserve tank
2	Reserve tank cap

2. If no coolant is in the reserve tank, follow the steps below to fill the tank.
 - [1] Remove the radiator cap.
 - [2] Supply clean water and antifreeze up to the opening of the radiator.
 - [3] Install the radiator cap.
 - [4] Remove the reserve tank cap.
 - [5] Supply clean water and antifreeze up to the "FULL" mark in the reserve tank.
 - [6] Install the reserve tank cap.

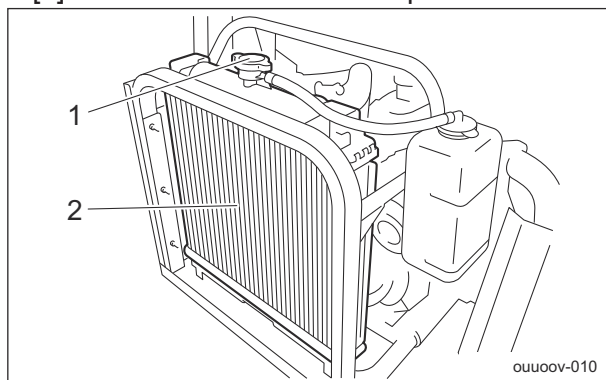

Supply of Coolant_002

1	Radiator cap
2	Radiator

Main Vehicle

Supply of Hydraulic Oil

⚠ Caution

Keep fire away while supplying the hydraulic oil.
Do not smoke.

Important

Supply hydraulic oil after checking the oil in the hydraulic tank has been sufficiently cooled down.
Oil level changes depending on the hydraulic oil temperature.

Important

Do not mix different types of oil.

Important

For the hydraulic oil to be used, consult Characteristics of Hydraulic Oil and use the oil whose characteristics are equivalent or superior to those specified there. Especially regarding kinematic viscosity and viscosity index, use of hydraulic oil whose figures are less than those of the specified hydraulic oil will cause a malfunction in the hydraulic circuit.

■ Characteristics of Hydraulic Oil

ISO Viscosity Grade		ISO VG46
Density	15 °C (59 °F)	0.873 g/cm ³ (0.0315 lb/in ³)
API Gravity		30.6
Flash Point (Open Cup)		230 °C (446 °F)
Pour Point		-30 °C (-22 °F)
Kinematic	40 °C (104 °F)	46 mm ² /s (46 cSt)
Viscosity	100 °C (212 °F)	7 mm ² /s (7 cSt)
Viscosity Index		109

Maintenance

■ Characteristics of Hydraulic Oil with conditions of use

Hydraulic oil of ISO viscosity grade VG68 can be used only if the following condition is met:

- The outside temperature must be 20 °C (68 °F) or more during engine operation.

ISO Viscosity Grade		ISO VG68
Density	15 °C (59 °F)	0.878 g/cm ³ (0.0318 lb/in ³)
API Gravity		29.7
Flash Point (Open Cup)		252 °C (486 °F)
Pour Point		-30 °C (-22 °F)
Kinematic Viscosity	40 °C (104 °F)	68 mm ² /s (68 cSt)
	100 °C (212 °F)	9 mm ² /s (9 cSt)
Viscosity Index		107

Note:

In Japan, "Shell Tellus S2M46 (ISO VG46)" and "Shell Tellus S2M68 (ISO VG68)" meet the characteristics described above.

However, in other countries, the specification of Shell Tellus S2M46 and Shell Tellus S2M68 can be below what is required.

Please check the product data sheet to ensure that it meets the requirements before using.

If the hydraulic oil level is low, follow the steps below to supply oil.

1. Lower the mower unit on a level surface, and stop the engine.
2. Open the hood.
3. Open the tank cap.
4. Supply the hydraulic oil through the oil filler port until the oil level reaches the middle of the oil gauge on the hydraulic tank.
5. Tighten the tank cap securely.

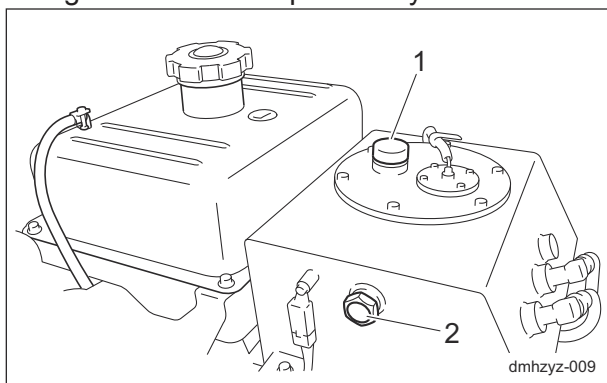

Supply of Hydraulic Oil_001

1	Tank cap
2	Oil gauge

6. Start the engine, and then repeat the steps below a few times.

- Raise and lower the mower units.
- Turn the steering wheel left and right.
- Move forward and reverse.

7. Lower the mower units and maintain that position on a level surface, and then check to see if the oil level is at the middle of the oil gauge.

If the hydraulic oil level is low, supply oil again until it reaches the specified level.

8. Check underneath the machine for oil leakage.
9. Close the hood.

Supply of Battery Fluid

⚠ Danger

If battery fluid comes into contact with eyes, it may result in blindness. Immediately flush with plenty of water and take medical care from an ophthalmologist.

⚠ Danger

Do not drink battery fluid.
If battery fluid enters the mouth or is swallowed, it may result in burns inside the mouth. Immediately and repeatedly gargle with plenty of water, then drink plenty of water, and take medical care.

⚠ Danger

When you supply battery fluid, wear protective garments and safety glasses, etc.

⚠ Warning

If battery fluid adheres to the skin or clothing, it may cause burns or damage clothing. Immediately flush with plenty of water, then wash thoroughly with soap.

⚠ Warning

Do not allow the battery fluid level to become lower than the LOWER LEVEL (minimum fluid level line).
The battery may explode if it is used or charged while the battery fluid level is at the LOWER LEVEL (minimum fluid level line).

⚠ Warning

When refilling, do not fill purified water above the UPPER LEVEL (maximum fluid level line). Doing so may result in electrolyte leaks.

⚠ Caution

Implement after the engine and muffler etc. have well cooled down.
Otherwise, you may get burned.

Important

If battery fluid adheres to the vehicle, it may cause corrosion.
Wipe it off with a cloth dampened with water, and then flush with water.

If the battery fluid level is lower than halfway between the UPPER LEVEL (maximum fluid level line) and LOWER LEVEL (minimum fluid level line), add purified water.

1. Loosen the vent plug and remove it.
2. Add purified water up to the UPPER LEVEL (maximum fluid level line)
3. Tighten the vent plug securely.

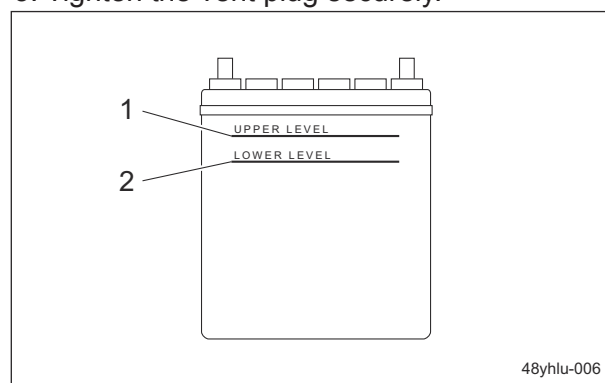

48yhlu-006

Supply of Battery Fluid_001

1	Maximum fluid level line
2	Minimum fluid level line

Maintenance

Greasing

About Greasing

Since there may be adhesion or damage due to lack of grease on moving parts, they must be greased.

Add urea-based No. 2 grease in accordance with the Maintenance Schedule.

Other locations where the specified grease or lubricant is used are indicated in "Greasing Points".

Add grease using the specified grease or lubricant.

Greasing Points

Grease nipples are installed in the following locations.

Add grease to A every 8 hours, to B every 50 hours and to C before work.

If specified locations and periods are additionally described below, follow the instructions.

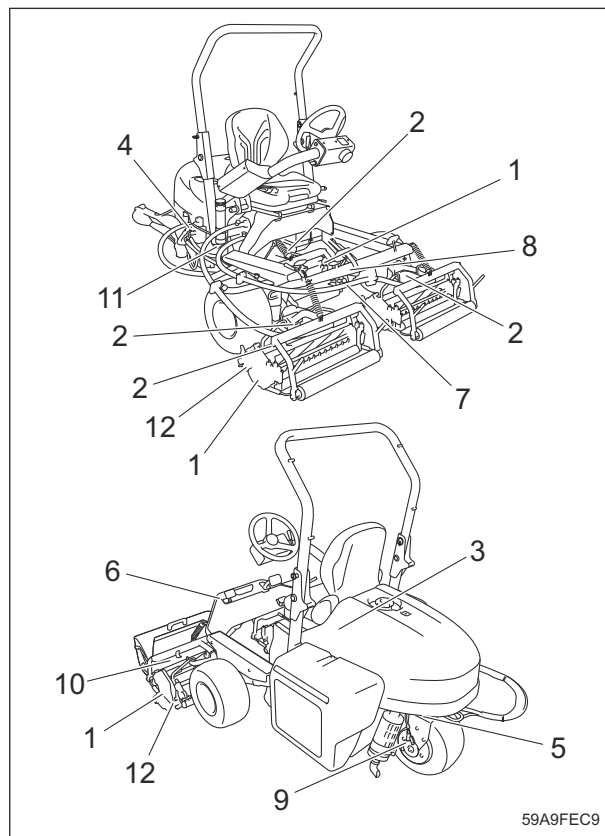

Greasing Points_001

	Location	No. of greasing points	Greasing schedule		
			A	B	C
1	Mower unit	42	A	B	-
2	Mower arm fulcrum	6	-	B	-
3	Belt tension lever	1	-	B	-
4	Neutral position area	1	-	B	-
5	Rear wheel pivot	1	-	B	-
6	Mower pedal shaft fulcrum (Mower pedal model)	1	-	B	-
7	Flexible wire bracket	1	-	B	-
8	Traveling pedal shaft fulcrum	1	-	B	-
9	Rear wheel brake lever shaft	1	-	B	-
10	Flexible wire edge	3	-	B	-
11	Flexible wire (-#31901)	6	A	-	C
	Flexible wire (#31902-)	7	A	-	C
12	Cam bush	2	Refer to "Maintenance Schedule"		

1. Mower unit

Each mower unit has 14 points.

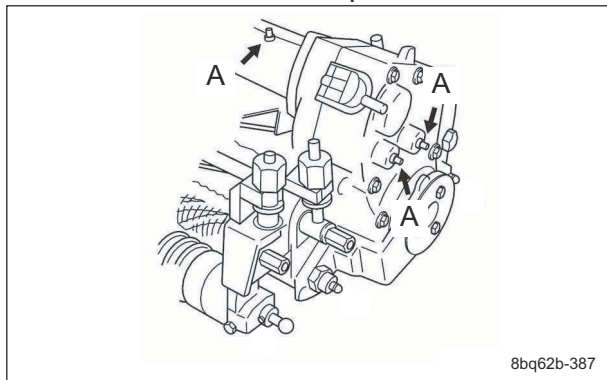

8bq62b-387

Greasing Points_002

Left frame

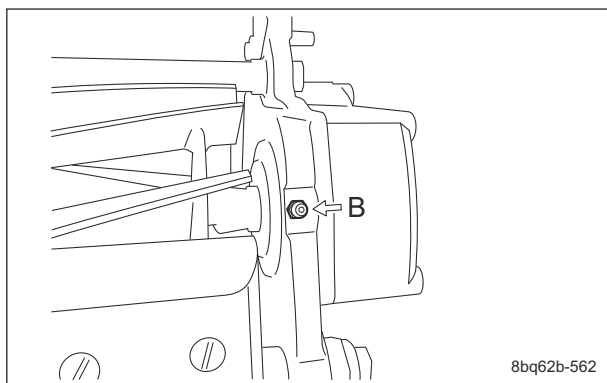

8bq62b-562

Greasing Points_003

Right reel housing

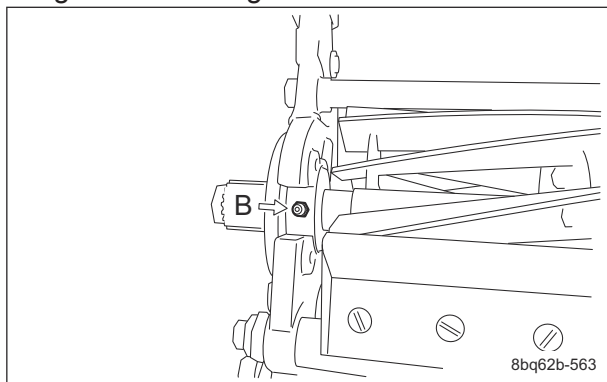

8bq62b-563

Greasing Points_004

Front roller

Note:

Depending on the specifications, this function may not be available.

Split roller has no greasing point.

Left side

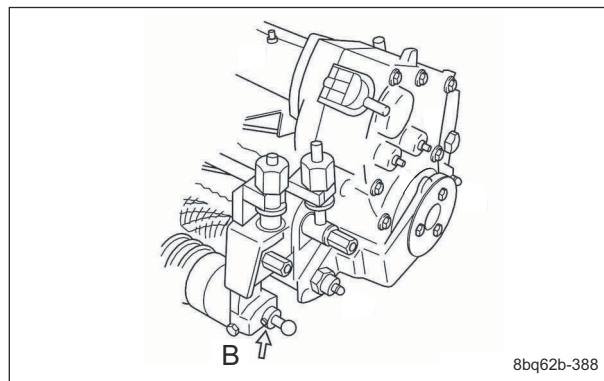

8bq62b-388

Greasing Points_005

Right side

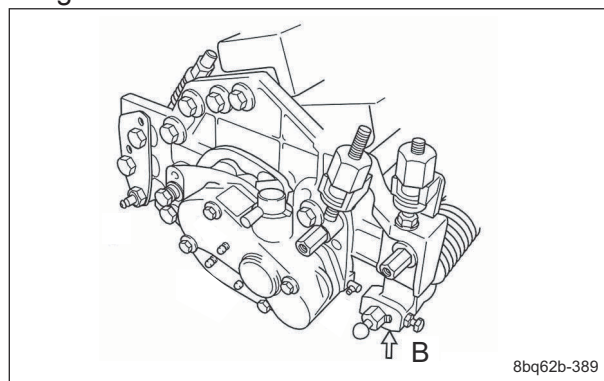

8bq62b-389

Greasing Points_006

Rear roller

Note:

Depending on the specifications, this function may not be available.

Left side

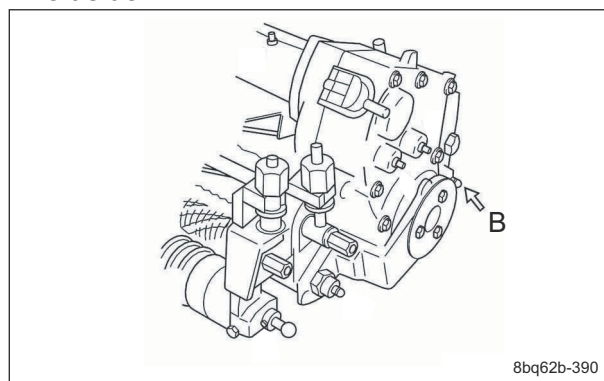

8bq62b-390

Greasing Points_007

Maintenance

Right side

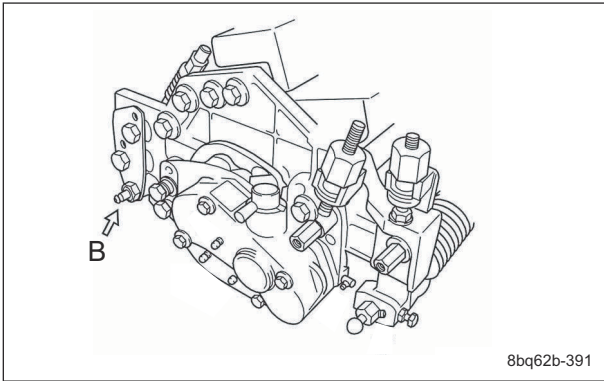

Greasing Points_008

Groomer

Note:

Depending on the specifications, this function may not be available.

Left side

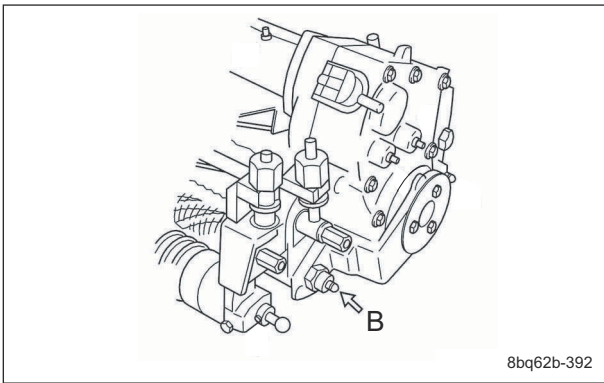

Greasing Points_009

Right side

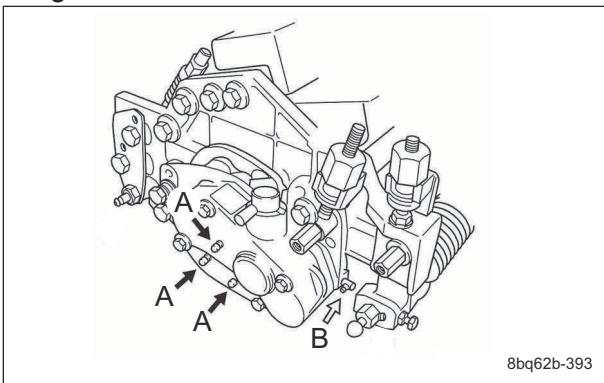

Greasing Points_010

2. Mower arm fulcrum

Important

Without greasing the mower arm fulcrum, the worn shaft can cause backlash in the lift arm and mower arm. The backlash may influence up-down range of the mower unit and cutting finish.

[1] Front mower unit (#2 · #3)

There are two greasing points on each mower unit.

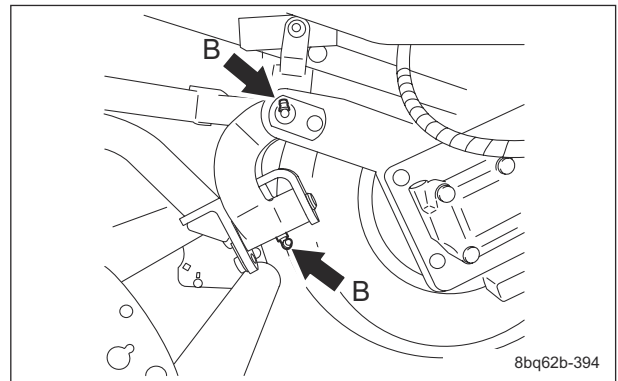

Greasing Points_011

[2] Rear mower unit (#1)

There are two locations.

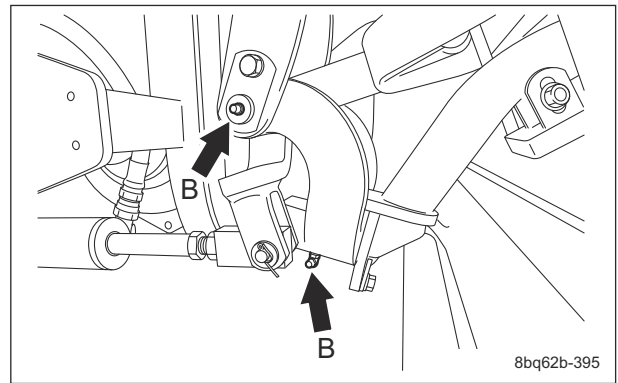

Greasing Points_012

3. Belt tension lever

Important

Without greasing the tension lever, it can adhere.

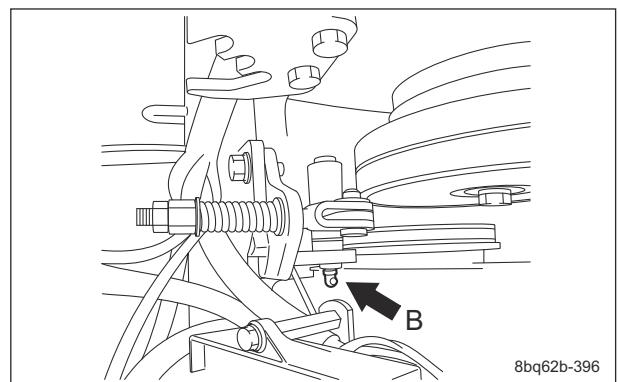

Greasing Points_013

4. Neutral position area

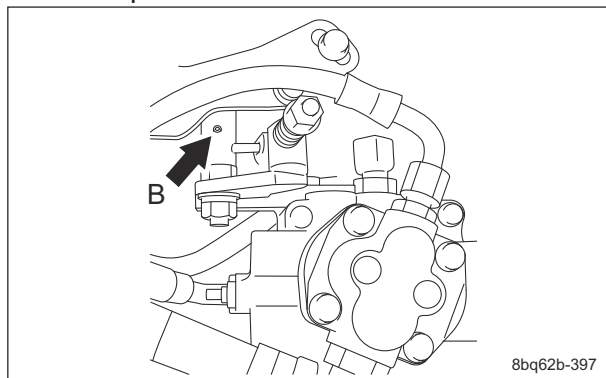

Greasing Points_014

5. Rear wheel pivot

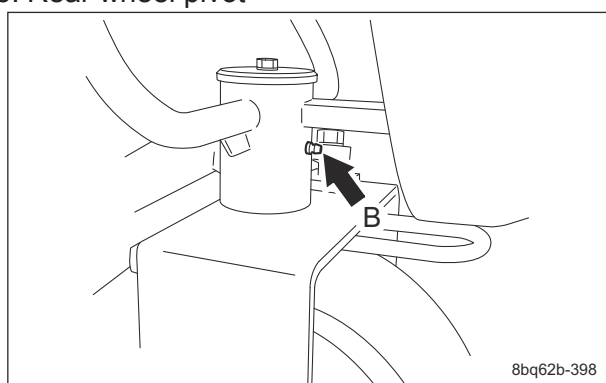

Greasing Points_015

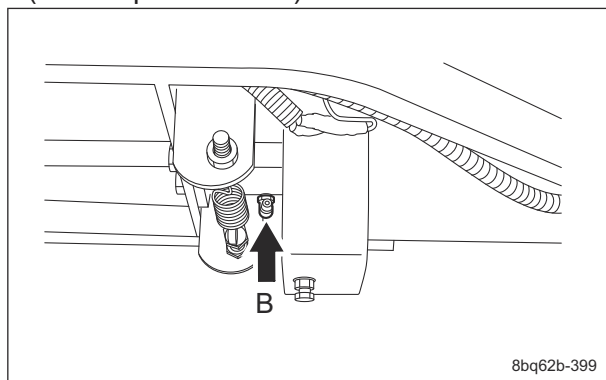
6. Mower pedal shaft fulcrum
(Mower pedal model)

Greasing Points_016

7. Flexible wire bracket

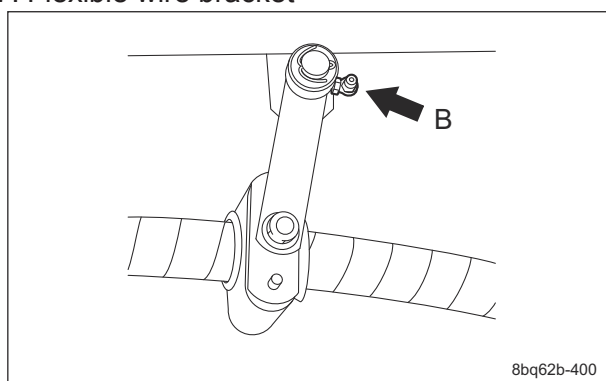

Greasing Points_017

8. Traveling pedal shaft fulcrum

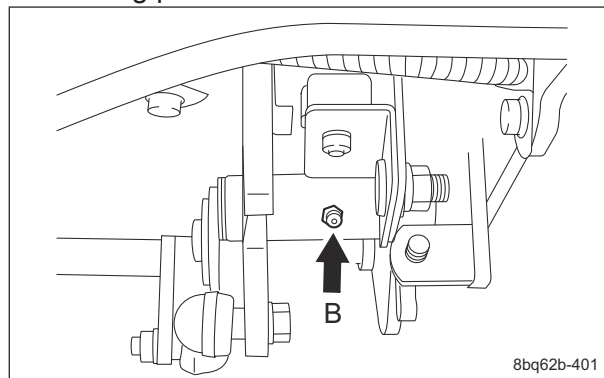

Greasing Points_018

9. Rear wheel brake lever shaft

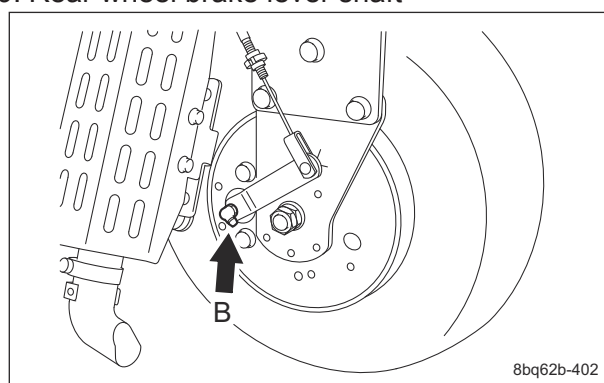

Greasing Points_019

10. Flexible wire edge

There is one greasing point on each flexible wire.

Grease by one stroke (1.0 mL).

Use Moly speed grease No.2.

Note:

Moly speed grease No.2 is a Bentone grease formulated with molybdenum disulfide that has excellent wear resistance and anti-seizure properties. Little dripping at high temperature.

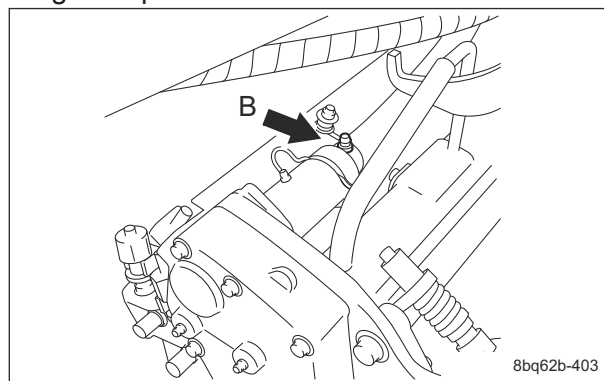

Greasing Points_020

Maintenance

Important

Lack of grease in the flexible wire may cause damage to it.
 Grease according to the maintenance schedule.
 The inner cable is a strand wire. Lack of grease in the strand wire may cause friction inside it resulting in damage due to abnormal heat generation.

11. Flexible wire

Use Moly speed grease No.2.

Note:

Moly speed grease No.2 is a Bentone grease formulated with molybdenum disulfide that has excellent wear resistance and anti-seizure properties. Little dripping at high temperature.

■ -#31901

Screw in the grease cup in each section by one turn for greasing.

Note:

Follow the steps below for greasing if the grease cup of the flexible wire has been screwed in fully.

- [1] Remove the grease cup.
- [2] Add grease fully to the grease cup without aeration.
- [3] Screw in the grease cup by two turns for installation.

Main vehicle side

There are three greasing points.

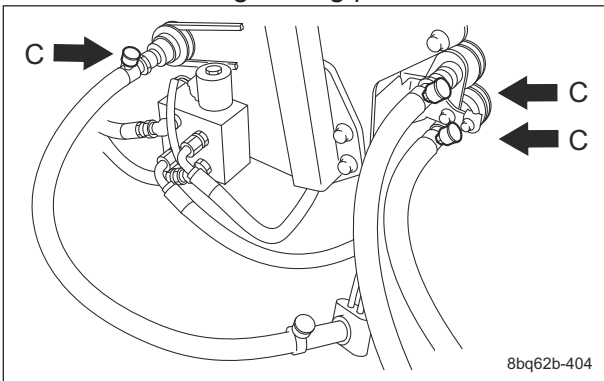

Greasing Points_021

Central part

There are three greasing points.

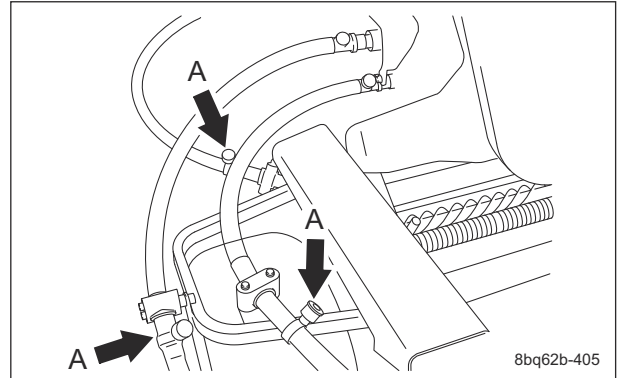

Greasing Points_022

■ #31902-

Grease each point by one stroke (1.0 mL).

Rear mower unit side

There are two greasing points.

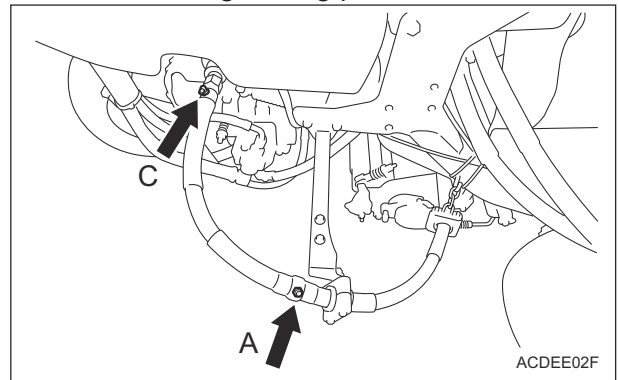

Greasing Points_023

Front mower unit side

There are five greasing points.

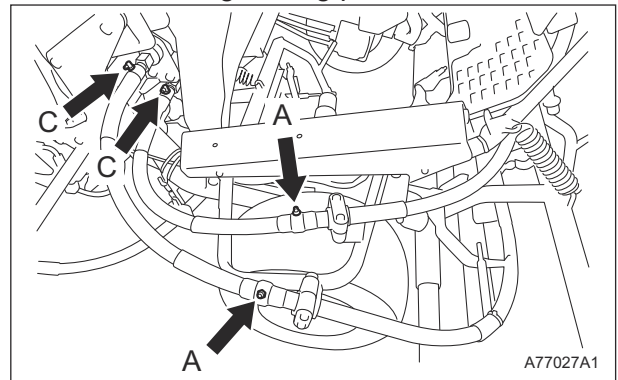

Greasing Points_024

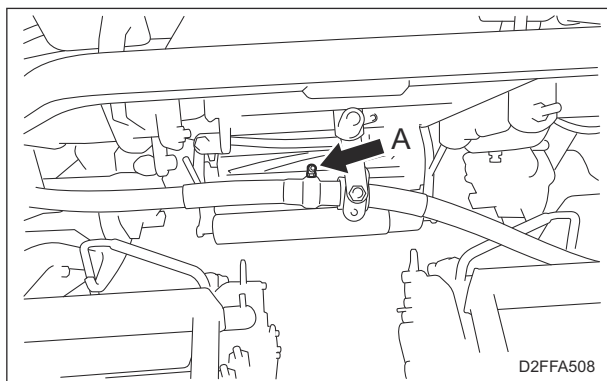

Greasing Points_025

12. Cam bush

There is one greasing point on each right and left side.

Apply 0.5 g (0.001 lb) of grease to the outer periphery of the cam bush pipe according to the maintenance schedule.

Left side

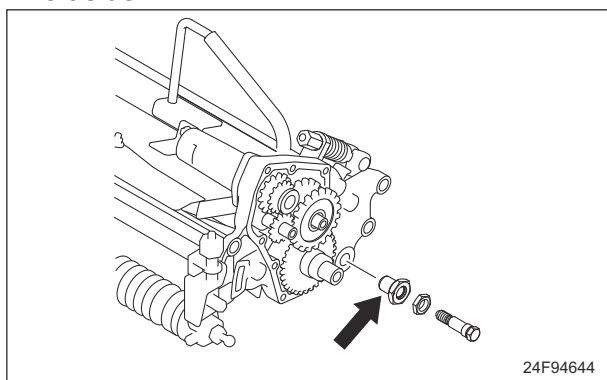

Greasing Points_026

Right side

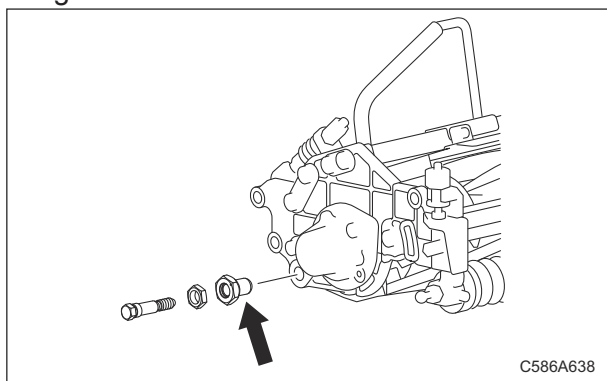

Greasing Points_027

Lubrication

About Lubrication

It is necessary to lubricate moving parts so that they will not become stuck or damaged. The locations where lubricant is used are indicated in "Lubricating Points". Apply the lubricant.

Lubricating Points

Apply lubricant at the following locations every 50 hours of operation.

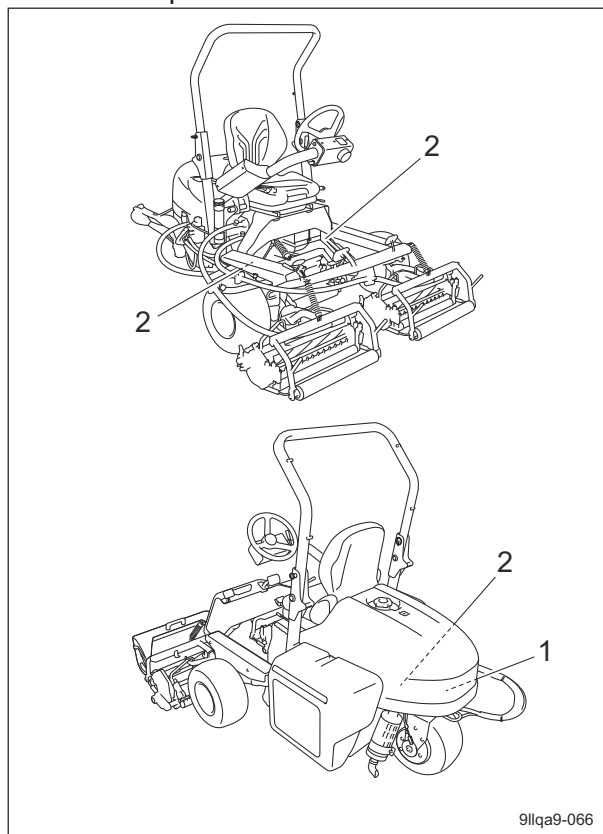

Lubricating Points_001

	Location	No. of lubricating points
1	Steering cylinder spherical bearing	1
2	Mower up/down cylinder spherical bearing	3

1. Steering cylinder spherical bearing

There is one point.

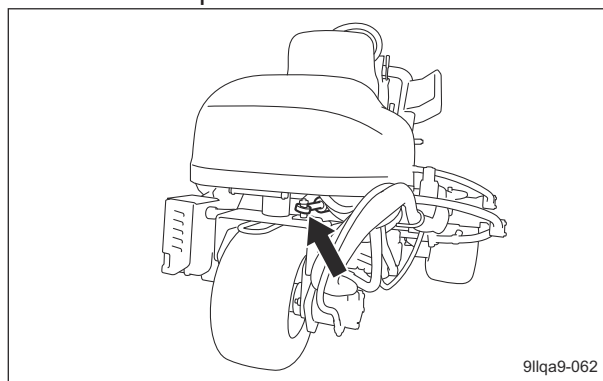

Lubricating Points_002

Maintenance

2. Mower up/down cylinder spherical bearing

There is one point each on the mower up/down cylinders.

Rear mower unit (#1)

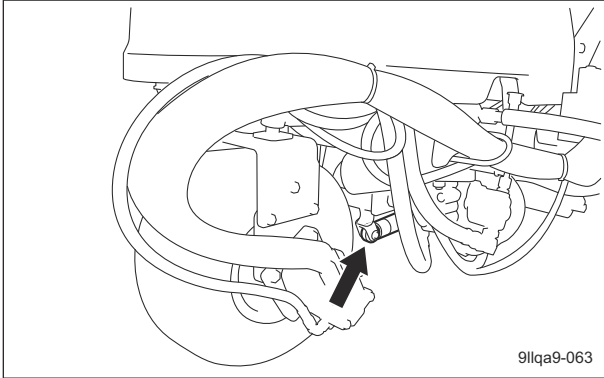

Lubricating Points_003

Left mower unit (#3)

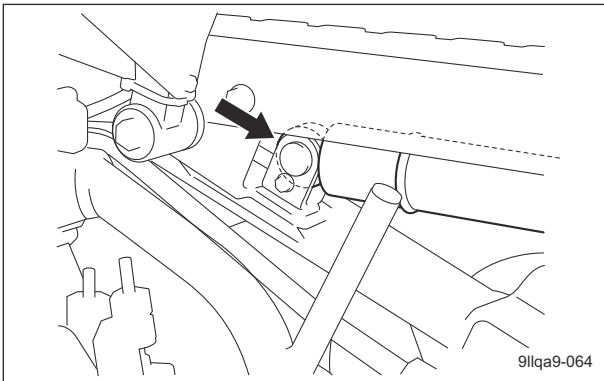

Lubricating Points_004

Right mower unit (#2)

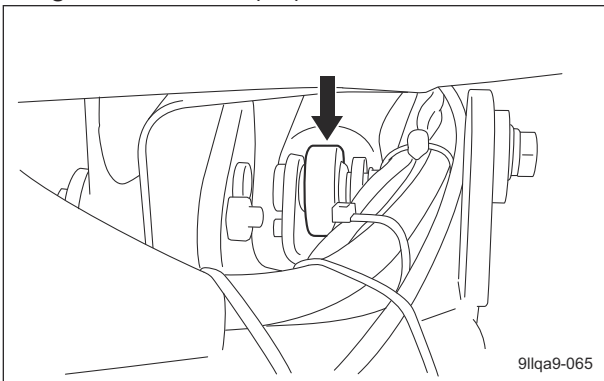

Lubricating Points_005

Adjustment

Engine

Adjustment of Fan Belt

Warning

Be sure to stop the engine before inspecting or adjusting the fan belt.

Warning

If a cover is removed due to inspection or adjustment, be sure to reinstall it in its original location.

Important

A slacking or damaged fan belt will cause overheating or lack of battery charge. Adjust or replace the belt.

For fan belt adjustment, follow either of the methods below.

1. Adjustment on the basis of belt slack deviation when applying a specified load to a specified place

[1] Press the middle of the belt with your finger to check the belt tension.

The belt tension is appropriate when the belt slacks by approximately 7 - 9 mm (0.28 - 0.35 in) when you apply a force of 98 N (10 kgf) to the belt at the middle point between the pulleys.

[2] If the belt tension is inappropriate, loosen the bolts and nuts fixing the alternator, and then move the alternator to adjust the tension.

[3] Tighten the bolts and nuts securely.

[4] After adjustment of belt tension, check the belt tension again.

If the belt tension is still not at the appropriate value after repeating the adjustment several times, replace the belt with a new one.

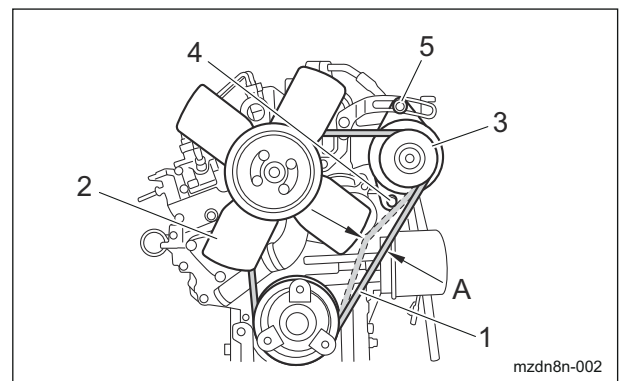

Adjustment of Fan Belt_001

1	Fan belt
2	Blade
3	Alternator
4	Nut
5	Bolt
A	7 - 9 mm (0.28 - 0.35 in)

2. Adjustment to suitable belt tension force by using sonic type tension meters at a specified point

Important

Perform correct measurement in accordance with the operations manual of the equipment being used for tension measurement.

Important

Perform measurement immediately after mounting the belt, when the pulley is not rotating.

- [1] Measure belt tension force by using a sonic type tension meter.
For measurement position and distance between pulleys, see diagram below.
Here is the suitable belt tension force.

Adjustment	200 - 300 N	20.39 - 30.59 kgf
Replacement	344 - 441 N	35.08 - 44.97 kgf

- [2] If the belt tension is inappropriate, loosen the bolts and nuts fixing the alternator, and then move the alternator to adjust the tension.
- [3] Tighten the bolts and nuts securely.
- [4] After adjustment of belt tension, check the belt tension again.
If the belt tension is still not at the appropriate value after repeating the adjustment several times, replace the belt with a new one.

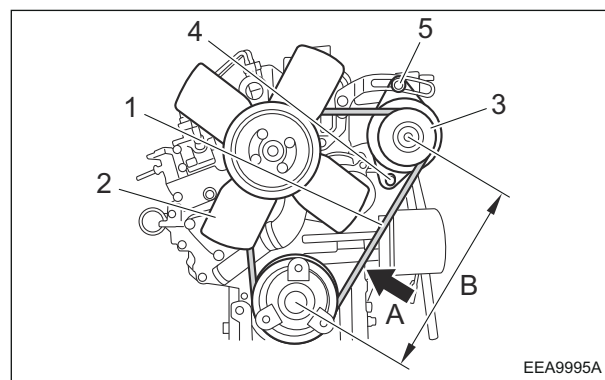

Adjustment of Fan Belt_002

1	Fan Belt
2	Blade
3	Alternator
4	Nut
5	Bolt
A	Measurement position
B	Distance between pulleys

Main Vehicle

Adjustment of Reel Cutter Drive Belt

1. Tilt the underseat cover forward and open the cover.
2. Open the hood.
3. Check the belt tension.
The criterion for the belt tension is that the belt slacks approximately 13 ± 2 mm (0.51 ± 0.08 in) when you apply a force of 55 N (5.5 kgf) with your finger to the belt at the middle point between the pulleys.
4. If the belt tension is not at the approximate value, follow the steps below to adjust it.
 - [1] Loosen the bolts.
 - [2] Move the position of the flexible wire housing (the pulley attached) to adjust the tension.
 - Belt stretches when the flexible wire housing is moved to the direction A.
 - Belt slacks when the flexible wire housing is moved to the direction B.

Maintenance

[3] Tighten the bolts.

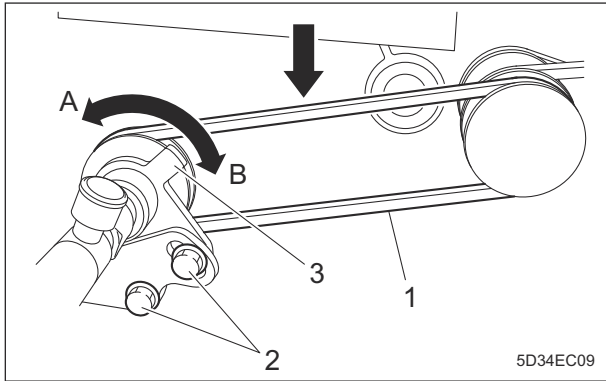

Adjustment of Reel Cutter Drive Belt_001

1	Reel cutter drive belt
2	Bolt
3	Flexible wire housing
A	Stretch
B	Slacken

- After adjustment of the belt tension, check the belt tension again. If the belt tension is still not at the approximate value after repeating the adjustment several times, replace the belt with a new one.
- Close the hood.

Adjustment of Transmission Input Belt

Important

Check adhesion of the tension lever. It may shorten the belt lifetime.

- Tilt the underseat cover forward and open the cover.
- Open the hood.
- Check the belt tension. The criterion for the belt tension is that the spring length is approximately 50 mm (1.97 in) with the belt tensioned.

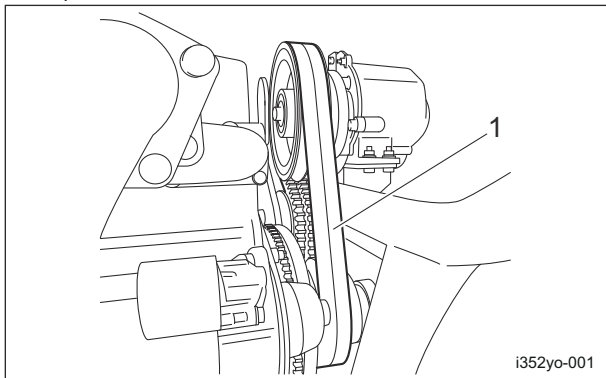

Adjustment of Transmission Input Belt_001

1	Engine tension belt
---	---------------------

- If the belt tension is not at the approximate value, follow the steps below to adjust it.
 - Loosen the nut.
 - Adjust the length of the spring.
 - Tighten the nut.

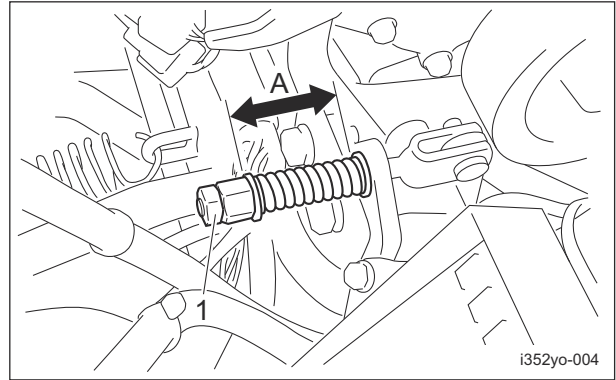

Adjustment of Transmission Input Belt_002

1	Nut
A	50 mm (1.97 in)

- After adjustment of the belt tension, check the belt tension again. If the belt tension is still not at the approximate value after repeating the adjustment several times, replace the belt with a new one.
- Close the hood.

Mower Unit

Back Lapping

Back lapping is work similar to sharpening a cooking knife. If the edges of the reel cutter (cutting cylinder) and the bed knife (bottom blade) become blunt and make cutting difficult, both the reel cutter (cutting cylinder) and the bed knife (bottom blade) should be simultaneously sharpened by reversing the reel cutter (cutting cylinder) with an abrasive paste applied.

However, back lapping is a temporary measure and would not restore the sharpness completely.

If the edges of the reel cutter (cutting cylinder) and the bed knife (bottom blade) become blunt and make cutting difficult, follow the steps below to perform back lapping.

Warning

During back lapping, the reel cutter (cutting cylinder) rotates. Keep hands and feet away from moving parts.

Caution

Be careful not to inhale exhaust gas during back lapping.

Caution

Do not perform back lapping with any other persons.

Caution

Be sure to stop the engine before and during shifting the transmission selector. Otherwise, your hands may get caught in the belt.

1. Have the following items ready: Strips of Takumi Paper (Baroness genuine strips) or newspaper, Abrasive [Back lapping powder mixed with oil; or gel compound (Baroness genuine abrasive)], Brush.

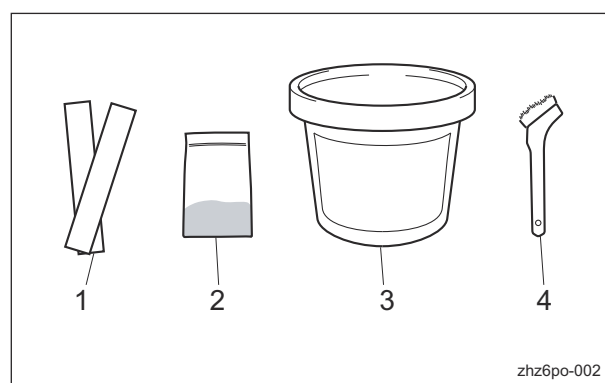

Back Lapping_001

1	Takumi Paper or newspaper
2	Back lapping powder
3	Gel compound
4	Brush

Note:

The mixing ratio for the abrasive, in volume, is one part back lapping powder (#200 - #400) to three or four parts oil.

Caution

When handling the reel cutter (cutting cylinder) or bed knife (bottom blade), wear gloves to protect your hands. Pay attention not to let the reel cutter (cutting cylinder) catch your gloves. Otherwise, you may injure your hand or fingers.

Important

Check the sharpness of the blade by checking the blade engagement after cutting grass.

2. Raise all the mower units.
3. Stop the engine.
4. Set the reel reverse lever for the mower units to the "Neutral" position.
5. Insert one or two strips of Takumi Paper or newspaper into the space between the reel cutter (cutting cylinder) and the bed knife (bottom blade) at an angle of 90 degrees. Then, rotate the reel cutter (cutting cylinder) counter-clockwise (when you face the mower unit from the left) to check the sharpness of the blades.
6. Check the sharpness of the entire range (three or four points) of the reel cutter (cutting cylinder).
7. Using a piece of chalk, mark locations on the blade that are sharp.

Maintenance

8. Set the reel reverse lever for the mower units to be back lapped to the "Reverse" position.
Shift the lever(s) to the "Neutral" position for the mower unit(s) for which you will not perform back lapping.
9. Set the transmission selector lever to the "Back lapping" position.
10. Take the operator's seat, apply the parking brake and then start the engine.
11. Lower all the mower units to the ground.
12. Reduce the engine rotation speed.
13. Set the reel rotation switch to the "Rotation" position to reverse the reel cutter (cutting cylinder).
14. Apply the abrasive evenly with the brush on the top side of reel cutter (cutting cylinder) where strips of Takumi Paper or newspaper were cut well or of chalk-marked locations. (Never apply to blunt areas.)

Important

The right side of the reel cutter (cutting cylinder) (when you face the mower unit from the front) tends to be worn earlier than the left side. Accordingly be sure to move the brush from the left to the right to apply the abrasive.

15. Let the reel rotate for a while and, when contact noise is no longer heard, return the reel rotation switch to the "Stop" position to stop the reel cutter (cutting cylinder).
16. Raise all the mower units.
17. Stop the engine.
18. Wash off or wipe off with a cloth, etc., the abrasive from the reel cutter (cutting cylinder), and then check it for sharpness.
19. Repeat steps 4 to 18 until the entire range (three or four points) of the reel cutter (cutting cylinder) will be uniformly sharpened.
20. Start the engine.
21. Lower all the mower units to the ground.
22. Finally, apply abrasive to the entire blade width of the reel cutter (cutting cylinder) and perform final back lapping.
23. Return the reel rotation switch to the "Stop" position to stop the rotation of the reel cutter (cutting cylinder), stop the engine, and then wash off the abrasive using a washer etc.

24. Set the transmission selector lever to the desired position.
25. Set the reel reverse lever to the "Neutral" position.
26. While checking the blade for sharpness, adjust blade engagement.

Adjustment of Blade Engagement

⚠ Caution

When handling the reel cutter (cutting cylinder) or bed knife (bottom blade), wear gloves to protect your hands. Pay attention not to let the reel cutter (cutting cylinder) catch your gloves. Otherwise, you may injure your hand or fingers.

1. Stop the engine.
2. Set the reel reverse lever to the "Neutral" position.

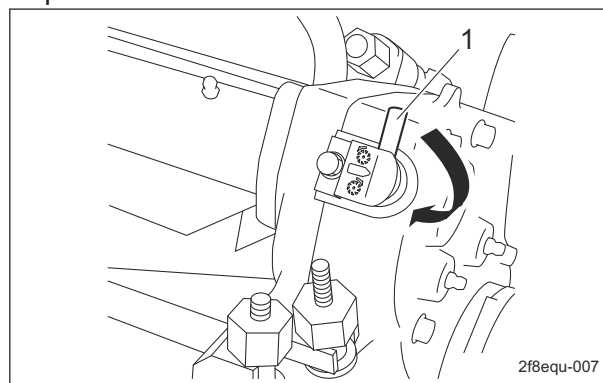

Adjustment of Blade Engagement_001

1 Reel reverse lever

3. Adjust the engagement between the reel cutter (cutting cylinder) and the bed knife (bottom blade) so that a strip of Takumi Paper (Baroness genuine paper strips) or newspaper will be cut cleanly by the edge of both blades when the blades in their entirety come slightly into contact with each other via the cutter adjustment nuts.

4. Insert a strip of Takumi Paper or newspaper into the space between the reel cutter (cutting cylinder) and the bed knife (bottom blade) at an angle of 90 degrees. Then, rotate the reel cutter (cutting cylinder) counter-clockwise (when you face the mower unit from the left) to check the sharpness of the blades.
- Check the sharpness of the entire range (three or four points) of the reel cutter (cutting cylinder).

- If a gap is created between edges:
Loosen (rotate counter-clockwise) the cutter adjustment nut to apply more contact pressure between the reel cutter (cutting cylinder) and the bed knife (bottom blade).
- If the reel cutter (cutting cylinder) is too tight to turn:
Tighten (rotate clockwise) the cutter adjustment nut to reduce the contact pressure between the reel cutter (cutting cylinder) and the bed knife (bottom blade).
- If the sharpness is not improved by the adjustment:
Perform back lapping.

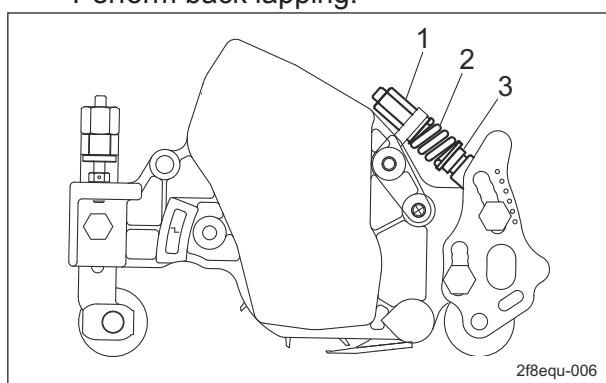

Adjustment of Blade Engagement_002

1	Cutter adjustment nut
2	Spring
3	Pipe with cutter adjusting screw

Maintenance

Adjustment of Cutting Height

Important

This applies the set cutting height that differs from the actual cutting height.

Adjust the cutting height to fit your cutting work.

■ Cutting Height and Blade Thickness of Bed Knife (Bottom Blade)

Important

The recommended minimum cutting heights are based on those of common greens. They may vary according to the green conditions and machine specifications. If the green undulation is hard, set it a little bit higher in order not to damage the green surface.

Blade thickness of the bed knife (bottom blade) roughly affects the recommended minimum cutting height like the figures below.

Thickness of blade (mm/inch)	Rough minimum cutting height (mm/inch)	Code	Part name	Remarks	
1.0/0.039	2.5/0.098	K2511000490	1 Bed knife (bottom blade) 22	Off set 2.5 mm	For green
		K2511000510	1 Bed knife (bottom blade) 22-44.5		
1.5/0.059	3.0/0.118	K2511000270	1.5 Bed knife (bottom blade) 55G	Off set 5 mm	For green
		K2510000320 (*)	1.5 Bed knife (bottom blade) 22		
		K2511000390	1.5 Bed knife (bottom blade) 55G-47		
		K2591000590	1.5 Bed knife (bottom blade) 55G-44.5		
2.0/0.079	3.5/0.138	K2511000280	2 Bed knife (bottom blade) 55G	Off set 5 mm	For green
		K2511000350	2 Bed knife (bottom blade) 55G-47		
		K2511000450	2 Bed knife (bottom blade) 56G-44.5		
2.5/0.098	4.0/0.157	K2511000050	2.5 Bed knife (bottom blade) 55G	Off set 5 mm	For green
		K2511000240	2.5 Bed knife (bottom blade) 55G-47		
3.0/0.118	4.5/0.177	K2510000060	3 Bed knife (bottom blade) 62.5-559		For teeing ground/For field

* : STD for GB

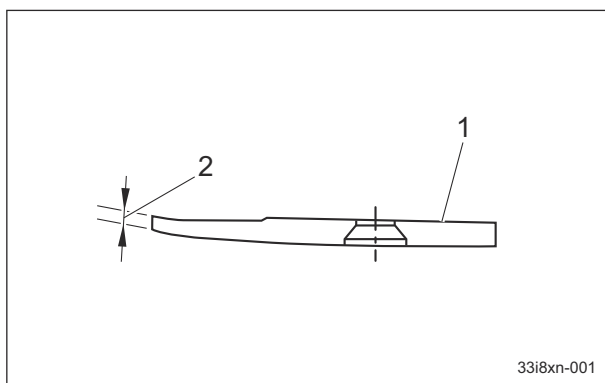

Cutting Height and Blade Thickness of Bed Knife (Bottom Blade)_001

1	Bed knife (bottom blade)
2	Thickness of blade

■ Adjustment of Rear Roller

Follow the steps below to set a position that suits your work requirements within the cutting height range.

1. Loosen the bolts.
2. Set the rear roller to the desired position.
3. Tighten the bolts to fix the rear roller.

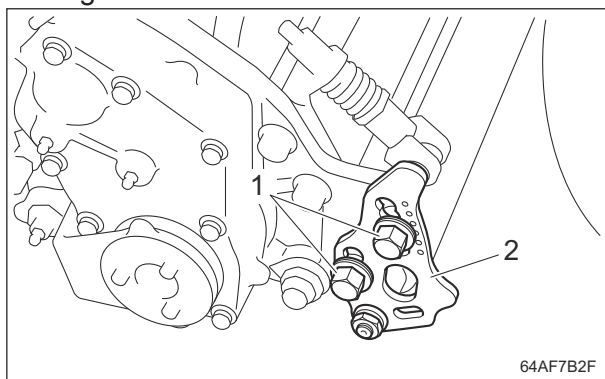

Adjustment of Rear Roller_001

1	Bolt
2	Rear roller bracket

- For greens mowing
You can adjust the rear roller by six stages.
The figure below shows the position of the rear roller bracket with a new reel cutter when using a 2.0 mm bed knife.
The lowest cutting height differs with thickness of the bed knife.
"Cutting Height and Blade Thickness of Bed Knife (Bottom Blade)" (Page 6-24)

Note:

With the same cutting height for settings B and C, the volume of clippings will be larger with C since the offset distance is longer.

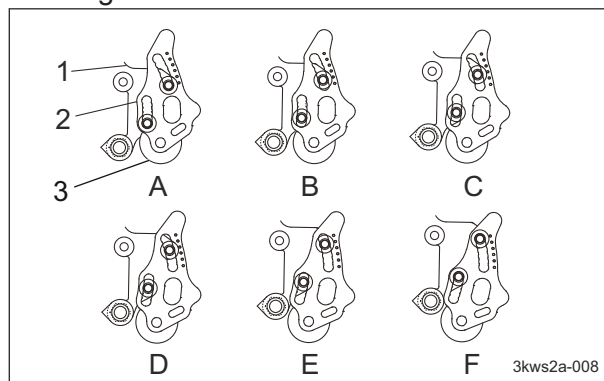

Adjustment of Rear Roller_002

1	Mower frame
2	Rear roller bracket
3	Rear roller
A	Use when the reel cutter is worn out
B	3.5 - 5.0 mm (0.138 - 0.197 in)
C	3.5 - 10.0 mm (0.138 - 0.394 in)
D	10.0 - 14.0 mm (0.394 - 0.551 in)
E	14.0 - 18.0 mm (0.551 - 0.709 in)
*	F 18.0 - 20.0 mm (0.709 - 0.787 in)

*Not recommended by manufacturer.

Maintenance

- For tees mowing
You can adjust the rear roller by eight stages.
The figure below shows the position of the rear roller bracket with a new reel cutter when using a 3.0 mm bed knife.
The lowest cutting height differs with thickness of the bed knife.
"Cutting Height and Blade Thickness of Bed Knife (Bottom Blade)" (Page 6-24)

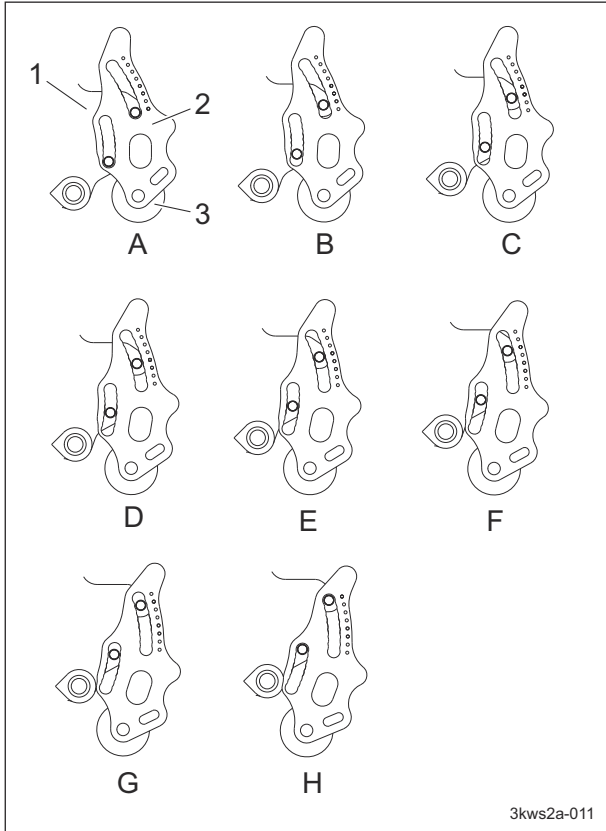

Adjustment of Rear Roller_003

1	Mower frame
2	Rear roller bracket
3	Rear roller
A	Use when the reel cutter is worn out
B	6.0 - 13.0 mm (0.236 - 0.512 in)
C	13.0 - 17.0 mm (0.512 - 0.669 in)
D	17.0 - 20.0 mm (0.669 - 0.787 in)
* E	20.0 - 25.0 mm (0.787 - 0.984 in)
* F	25.0 - 28.0 mm (0.984 - 1.102 in)
* G	28.0 - 32.0 mm (1.102 - 1.260 in)
* H	32.0 - 35.0 mm (1.260 - 1.378 in)

*Not recommended by manufacturer.

- For fields mowing
You can adjust the rear roller by eight stages.
The figure below shows the position of the rear roller bracket with a new reel cutter when using a 3.0 mm bed knife.
The lowest cutting height differs with thickness of the bed knife.
"Cutting Height and Blade Thickness of Bed Knife (Bottom Blade)" (Page 6-24)

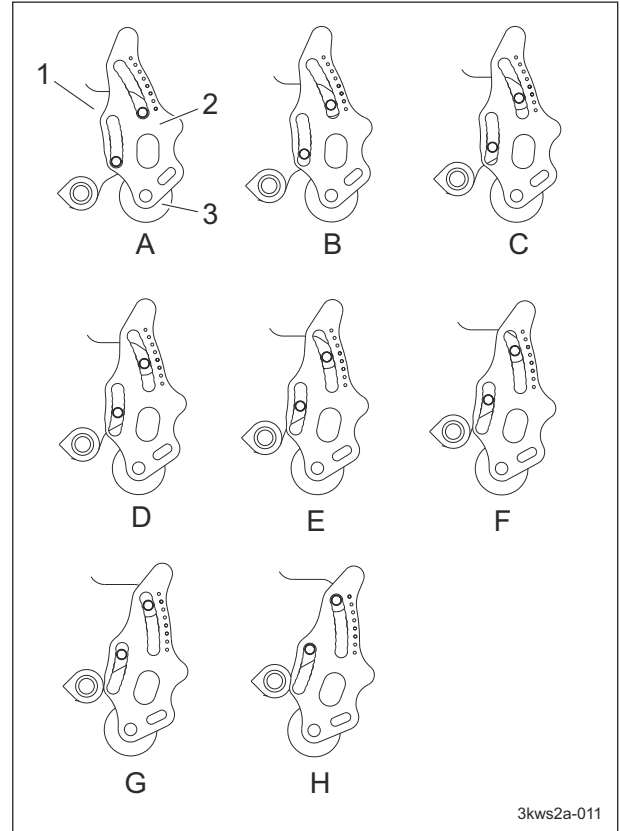

Adjustment of Rear Roller_004

1	Mower frame
2	Rear roller bracket
3	Rear roller
A	10.0 - 13.0 mm (0.394 - 0.512 in)
B	13.0 - 17.0 mm (0.512 - 0.669 in)
C	17.0 - 22.0 mm (0.669 - 0.866 in)
D	22.0 - 28.0 mm (0.866 - 1.102 in)
E	28.0 - 33.0 mm (1.102 - 1.299 in)
F	33.0 - 37.0 mm (1.299 - 1.457 in)
G	37.0 - 40.0 mm (1.457 - 1.575 in)
* H	40.0 - 43.0 mm (1.575 - 1.693 in)

*Not recommended by manufacturer.

■ Adjustment of Front Roller



Caution
Be sure to perform this adjustment on your own.

1. Set the slide caliper to the required cutting height, adjust the position of the bottom of the head of the cutting height setting screw on the cutting height gauge, and then securely lock it with a wing nut.

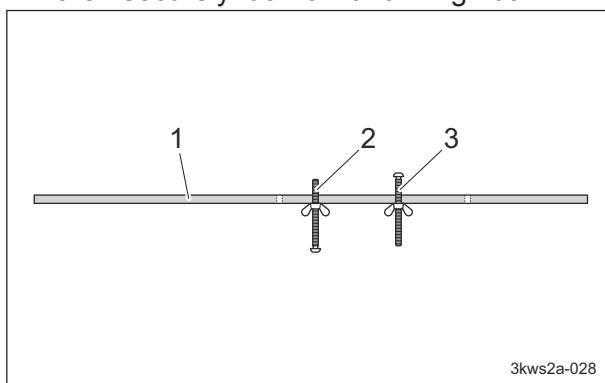

Adjustment of Front Roller_001

1	Cutting height gauge
2	Groomer setting screw
3	Cutting height setting screw

2. Loosen the left and right nuts that secure the front roller bracket.

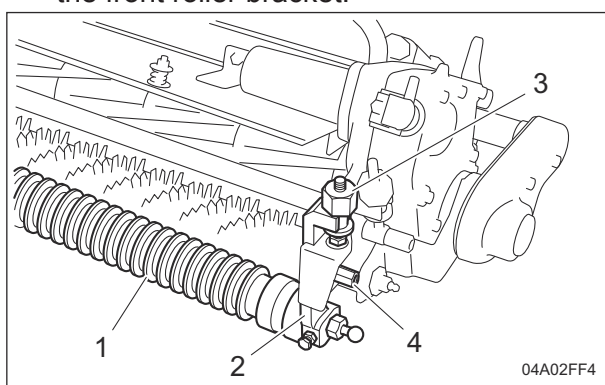

Adjustment of Front Roller_002

1	Front roller
2	Roller bracket
3	Roller adjustment bracket
4	Nut

3. Bring the cutting height gauge into contact with the front roller and rear roller at the left and right ends of the mower unit.

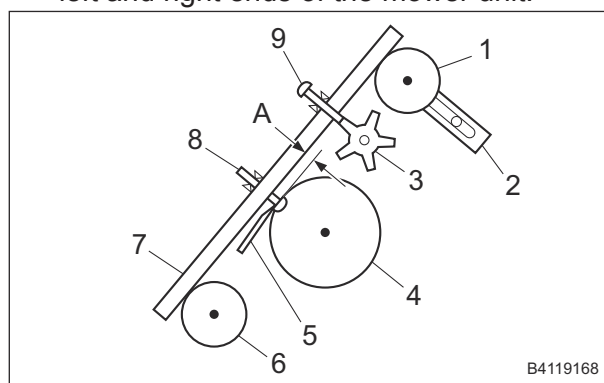

Adjustment of Front Roller_003

1	Front roller
2	Roller bracket
3	Front groomer
4	Reel cutter
5	Bed knife
6	Rear roller
7	Cutting height gauge
8	Cutting height setting screw
9	Groomer setting screw
A	Cutting height

4. Raise or lower the front roller with the roller adjustment bracket to set the position of the front roller so that there is no gap between the bottom of the head of the cutting height setting screw on the cutting height gauge and the tip position of the bed knife.

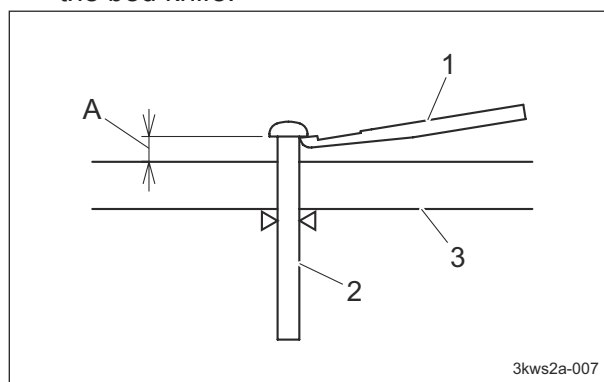

Adjustment of Front Roller_004

1	Bed knife
2	Cutting height setting screw
3	Cutting height gauge
A	Cutting height

5. Follow the same steps to adjust the cutting height on the opposite side.

Maintenance

6. Tighten the nuts securing the left and right roller brackets, and fix them securely.
7. Bring the cutting height gauge into contact with the front roller and rear roller at the left and right ends of the mower unit again, and check that it is at the desired cutting height.

Adjustment of Cutter Adjustment Spring

If the diameter of the reel cutter (cutting cylinder) becomes smaller, adjust the cutter adjustment spring.

1. Adjust the blade engagement.
2. Loosen the pipe with cutter adjusting screw, and then adjust the length of the spring coil to approximately 30 mm (1.18 in).

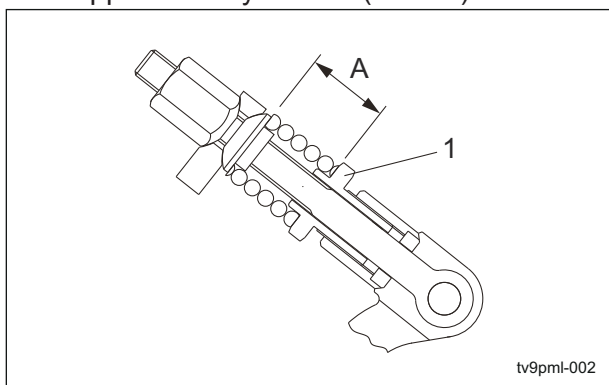

Adjustment of Cutter Adjustment Spring_001

1	Pipe with cutter adjusting screw
A	30 mm (1.18 in)

Adjustment of CAM

When the gap at the left frame side between the reel cutter (cutting cylinder) and the bed knife (bottom blade) appears.

1. Loosen the locknut and turn the left cam bush clockwise for the gap size.
When you raise the bed knife (bottom blade) for 0.1mm (0.039 inch), turn the left cam bush clockwise for 30 degrees.
2. Once the adjustment completed, tighten the locknut securely.

When the gap at the right frame side between the reel cutter (cutting cylinder) and the bed knife (bottom blade) appears.

1. Loosen the locknut and turn the right cam bush anticlockwise for the gap size.
2. Once the adjustment completed, tighten the locknut securely.

Note:

The figure below shows the situation when you see from the left frame.

The right frame is mirror reversed.

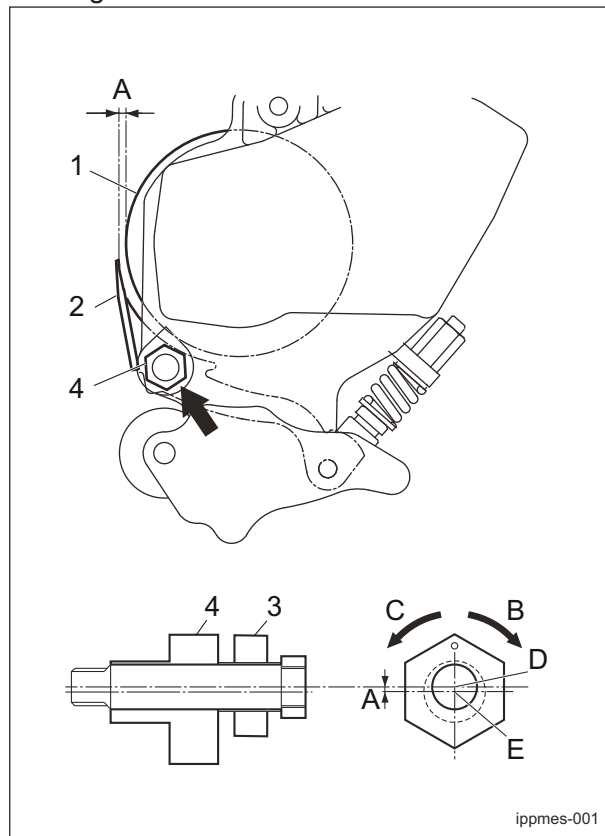

Adjustment of CAM_001

1	Reel cutter (Cutting cylinder)
2	Bed knife (Bottom blade)
3	Lock nut
4	Cam bush
A	Max 0.3 mm (0.012 inch)
B	Bed knife (bottom blade) moving up
C	Bed knife (bottom blade) moving down
D	Center of cutter pin
E	Center of cam bush

Sharpening of Reel Cutter (Cutting Cylinder)

The sharpening of the reel cutter (cutting cylinder) consists in maintaining its roundness and creating a relief (second edge face). This work should be performed if the sharpness cannot be restored, even after back lapping, or if the relief (second edge face) has worn away.

Sharpen the reel cutter (cutting cylinder) when the sharpness cannot be restored, even after back lapping, or when the relief (second edge face) has worn away, there is full contact or back lapping takes too much time.

In addition, if the reel cutter (cutting cylinder) becomes worn and its shape conical, perform cylindrical grinding to return it to a cylindrical shape.

For sharpening the reel cutter (cutting cylinder), contact your dealer or Baroness unless you have a grinding machine.

⚠ Caution

Both the reel cutter (cutting cylinder) and the bed knife (bottom blade) are edged tools. Handle them carefully, since they could cut your hands and feet.

⚠ Caution

Wear gloves when touching edged tools to avoid cutting your hands.

The criteria for sharpening the reel cutter (cutting cylinder) are described below. However, these criteria are only references and do not guarantee performance of a reel cutter (cutting cylinder).

1. If the outer diameter of the reel cutter (cutting cylinder) after sharpening is more than the usage limit, the reel cutter (cutting cylinder) can be sharpened.

New		Usage limit	
Dimension A (Outer diameter of reel cutter (cutting cylinder))	Dimension B (Distance from blade edge to outer edge of reel cutter (cutting cylinder) shaft)	Dimension A (Outer diameter of reel cutter (cutting cylinder))	Dimension B (Distance from blade edge to outer edge of reel cutter (cutting cylinder) shaft)
128 mm (5.04 in)	51.3 mm (2.02 in)	118 mm (4.65 in)	46.3 mm (1.82 in)

Note:

The outer diameter of the reel cutter (cutting cylinder) shaft is 25.4 mm (1.00 in).

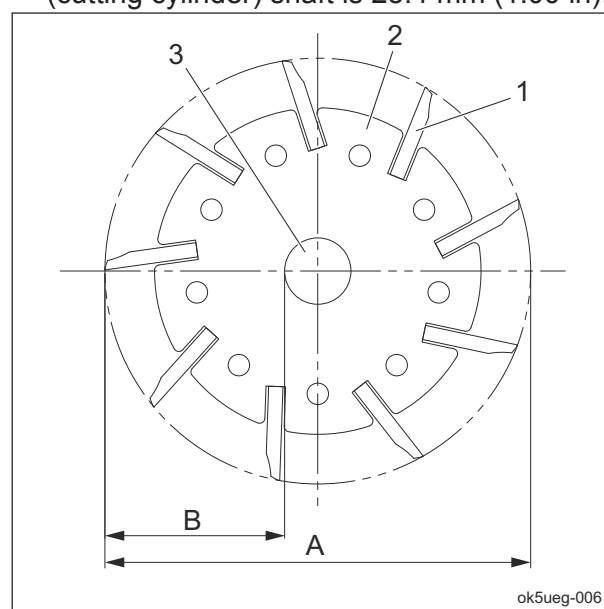

Sharpening of Reel Cutter (Cutting Cylinder)_001

1	Reel cutter (cutting cylinder) blade
2	Reel cutter (cutting cylinder) disc
3	Reel cutter (cutting cylinder) shaft
A	Outer diameter of reel cutter (cutting cylinder)
B	Distance from blade edge to outer edge of reel cutter (cutting cylinder) shaft

Maintenance

2. Sharpening is necessary when the reel cutter (cutting cylinder) reaches a condition described below.

[1] When the sharpening width (length of contacting surface of bed knife (bottom blade)) for the outer diameter of the reel cutter (cutting cylinder) is greater than the usage limit.

Outer diameter of reel cutter (cutting cylinder) (new part)	Usage limit of sharpening width for outer diameter of reel cutter (cutting cylinder)
128 mm (5.04 in)	2.5 mm (0.10 in) (factory-recommended)

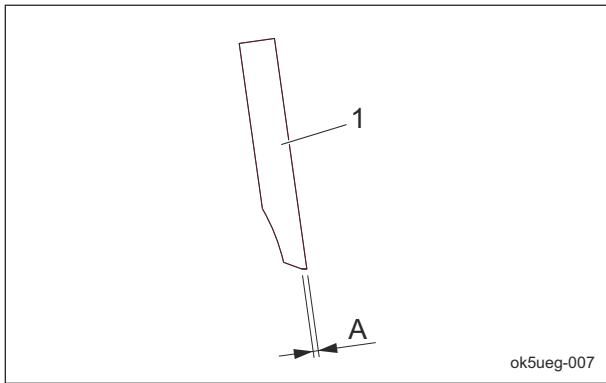

Sharpening of Reel Cutter (Cutting Cylinder)_002

1	Reel cutter (cutting cylinder) blade
A	Sharpening width for outer diameter of reel cutter (cutting cylinder)

[2] When the edges become blunt or the blade edge cannot be formed with back lapping

[3] When the reel cutter (cutting cylinder) becomes worn and its shape conical, or when blade engagement adjustment cannot be performed

Adjustment of Groomer

Note:
Depending on the specifications, this function may not be available.

Important

When using the front groomer, adjust it to suit the conditions on the green.

Important

For adjustment of groomer, be sure to use the cutting height gauge so that the left and right sides will be parallel.

Otherwise, it may cause damage on the bearings.

Important

Set the grooming height more than 0 mm (0.0 in) from the ground.

Setting the front groomer deeper than the ground surface will cause damage to the groomer shaft, bearings and gears etc.

Important

If the groomer is installed with a cutting height of 16 mm (0.63 in) or more, do not raise the groomer height by more than 5 mm (0.20 in) above the cutting height.

Otherwise, it may cause damage to the grass catcher and vertical blades.

Important

When using the thatching brush, set it to the same height as the cutting height.

If it is set lower, it will wear easily.

1. Set the groomer setting screw of the cutting height gauge to the desired height. Set the slide caliper to the required groomer height, adjust the tip of the groomer setting screw on the cutting height gauge, and then securely lock it with a wing nut.

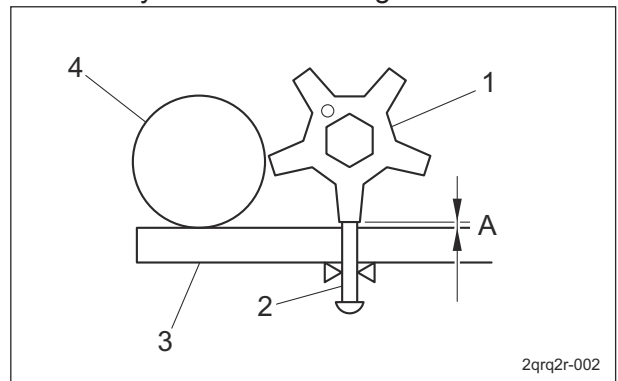

Adjustment of Groomer_001

1	Vertical blade
2	Groomer setting screw
3	Cutting height gauge
4	Front roller
A	Groomer height

2. Loosen the nut fixing the left groomer adjustment bolt.

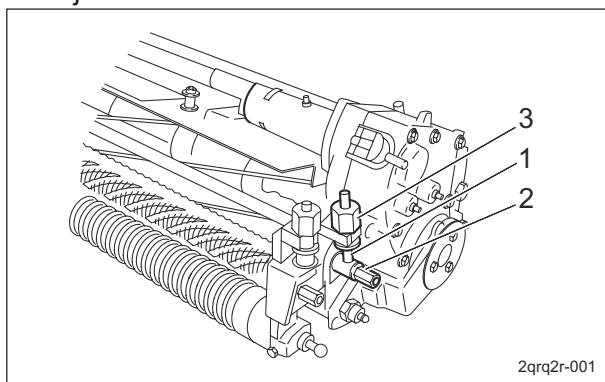

Adjustment of Groomer_002

1	Groomer adjustment bolt
2	Nut
3	Groomer adjuster

3. Loosen the nut fixing the right groomer adjustment bolt.
4. Bring the cutting height gauge into contact with the front roller and rear roller at the left and right ends of the mower unit.

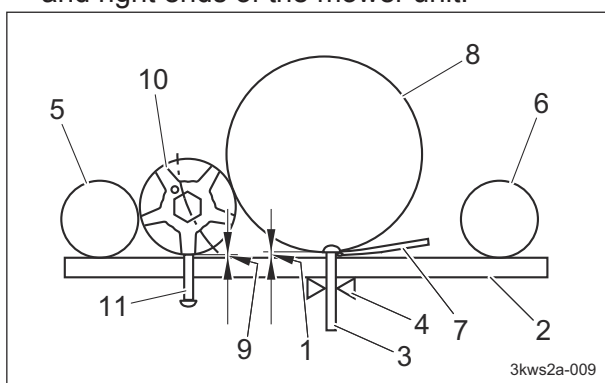

Adjustment of Groomer_003

1	Cutting height
2	Cutting height gauge
3	Cutting height setting screw
4	Nut
5	Front roller
6	Rear roller
7	Bed knife (bottom blade)
8	Reel cutter (cutting cylinder)
9	Groomer height
10	Front groomer
11	Groomer setting screw

Important

Adjust the position of the groomer setting screw so that it can contact with the vertical blades.

5. Adjust the groomer adjuster up and down so that the left and right sides can be parallel.
6. Firmly tighten the nut securing the left side groomer adjustment bolt.
7. Firmly tighten the nut securing the right side groomer adjustment bolt.
8. Bring the cutting height gauge into contact with the front roller and rear roller at the left and right ends of the mower unit again, and check that it is at the desired groomer height.

Maintenance

Adjustment of Thatching Reel

Note:

Depending on the specifications, this function may not be available.

Important

When using the thatching reel, adjust it to suit the conditions on the green.

Important

For adjustment of thatching reel, be sure to use the cutting height gauge so that the left and right sides will be parallel. Otherwise, it may cause damage on the bearings.

Important

Set the thatching reel height more than 0 mm (0.0 in) from the ground. Setting the thatching reel deeper than the ground surface will cause damage to the vertical shaft, bearings and gears etc.

Important

If the thatching reel is installed with a cutting height of 16 mm (0.63 in) or more, do not raise the thatching reel height by more than 5 mm (0.20 in) above the cutting height. Otherwise, it may cause damage to the grass catcher and vertical blades.

Important

When using the thatching brush, set it to the same height as the cutting height. If it is set lower, it will wear easily.

1. Set the caliper to the desired height of the thatching reel, align the tip of the thatching reel setting screw on the cutting height gauge, and lock it securely with a wing nut.

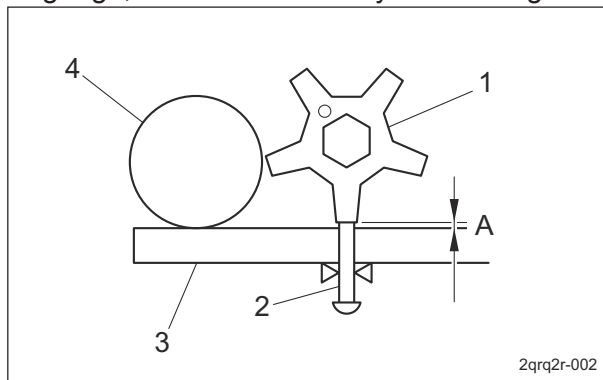

Adjustment of Thatching Reel_001

1	Vertical blade
2	Thatching reel setting screw
3	Cutting height gauge
4	Front roller
A	Thatching reel height

2. Loosen the nut fixing the left thatching reel adjustment bolt.

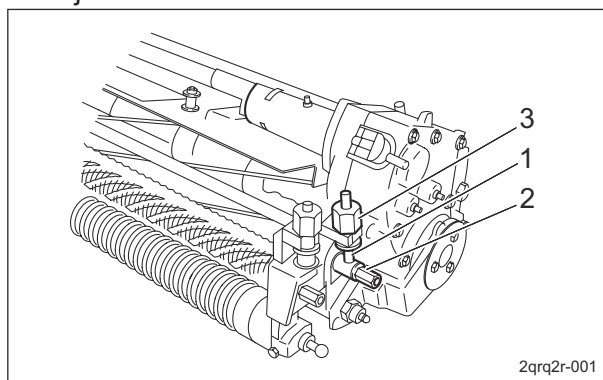

Adjustment of Thatching Reel_002

1	Thatching reel adjustment bolt
2	Nut
3	Thatching reel adjuster

3. Loosen the nut fixing the right thatching reel adjustment bolt.

4. Bring the cutting height gauge into contact with the front roller and rear roller at the left and right ends of the mower unit.

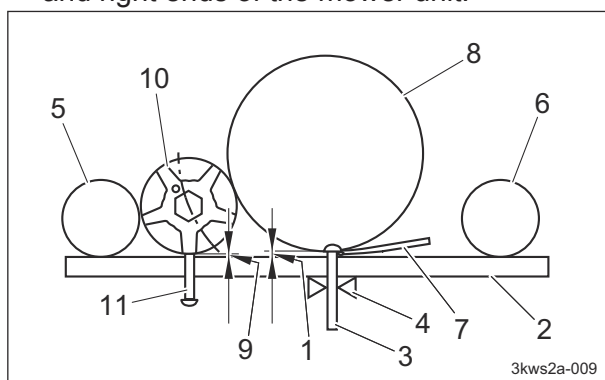

Adjustment of Thatching Reel_003

1	Cutting height
2	Cutting height gauge
3	Cutting height setting screw
4	Nut
5	Front roller
6	Rear roller
7	Bed knife (bottom blade)
8	Reel cutter (cutting cylinder)
9	Thatching reel height
10	Thatching reel
11	Thatching reel setting screw

Important

Adjust the position of the thatching reel setting screw so that it can contact with the vertical blades.

- Adjust the thatching reel adjuster up and down so that the left and right sides will be parallel.
- Firmly tighten the nut securing the left side thatching reel adjustment bolt.
- Firmly tighten the nut securing the right side thatching reel adjustment bolt.
- Bring the cutting height gauge into contact with the front roller and rear roller at the left and right ends of the mower unit again, and check that it is at the desired thatching reel height.

Adjustment of Thatching Brush**Note:**

Depending on the specifications, this function may not be available.

Important

Adjust the thatching brush to suit the conditions on the green.

Important

For adjustment of thatching brush, be sure to use the cutting height gauge so that the left and right sides will be parallel. Otherwise, it may cause damage on the bearings.

Important

Set the thatching brush height more than 0 mm (0.0 in) from the ground. Setting the thatching brush deeper than the ground surface will cause damage to the brush shaft, bearings and gears etc.

Important

If the thatching brush is installed with a cutting height of 16 mm (0.63 in) or more, do not raise the thatching brush height by more than 5 mm (0.20 in) above the cutting height. Otherwise, it may cause damage to the grass catcher and thatching brush.

Important

When using the thatching brush, set it to the same height as the cutting height. If it is set lower, it will wear easily.

- Set the caliper to the desired height of the thatching brush, align the tip of the thatching brush setting screw on the cutting height gauge, and lock it securely with a wing nut.

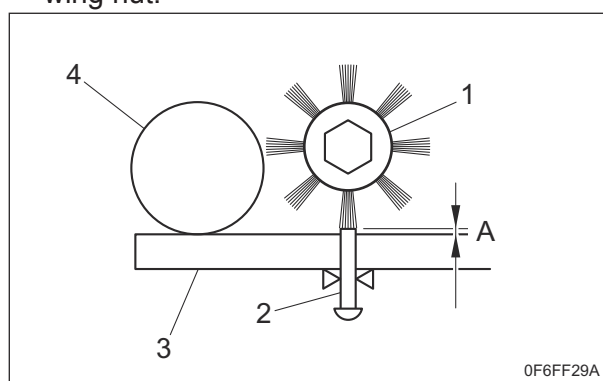

Adjustment of Thatching Brush_001

Maintenance

1	Thatching brush
2	Thatching brush setting screw
3	Cutting height gauge
4	Front roller
A	Thatching brush height

- Loosen the nut fixing the left thatching brush adjustment bolt.

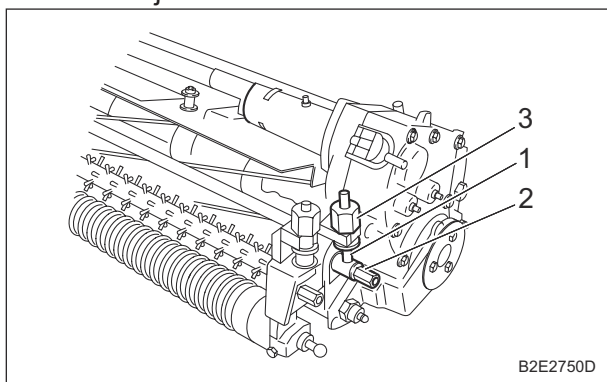

Adjustment of Thatching Brush_002

1	Thatching brush adjustment bolt
2	Nut
3	Thatching brush adjuster

- Loosen the nut fixing the right thatching brush adjustment bolt.
- Bring the cutting height gauge into contact with the front roller and rear roller at the left and right ends of the mower unit.

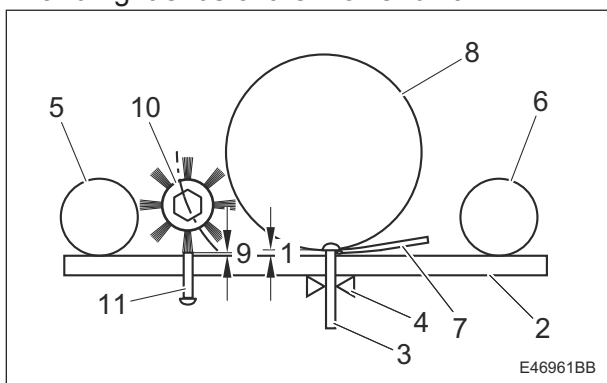

Adjustment of Thatching Brush_003

1	Cutting height
2	Cutting height gauge
3	Cutting height setting screw
4	Nut
5	Front roller
6	Rear roller
7	Bed knife (bottom blade)
8	Reel cutter (cutting cylinder)
9	Thatching brush height
10	Thatching brush
11	Thatching brush setting screw

Important

Adjust the position of the groomer setting screw so that it can contact with the vertical blades.

- Adjust the thatching brush adjuster up and down so that the left and right sides will be parallel.
- Firmly tighten the nut securing the left side thatching brush adjustment bolt.
- Firmly tighten the nut securing the right side thatching brush adjustment bolt.
- Bring the cutting height gauge into contact with the front roller and rear roller at the left and right ends of the mower unit again, and check that it is at the desired thatching brush height.

Adjustment of CR brush

Important

Do not press the brush hard against the rear roller. Doing so may cause the belt to slip or become severed.

Important

The CR brush prevents cut grass from sticking to the rear roller with the rotating brush.

- Loosen the left and right nuts.
- Raise or lower the brush shaft and adjust the gap between the brush tip and rear roller to 0 to 1 mm (0 to 0.4 in).

3. Tighten the loosened left and right nuts.

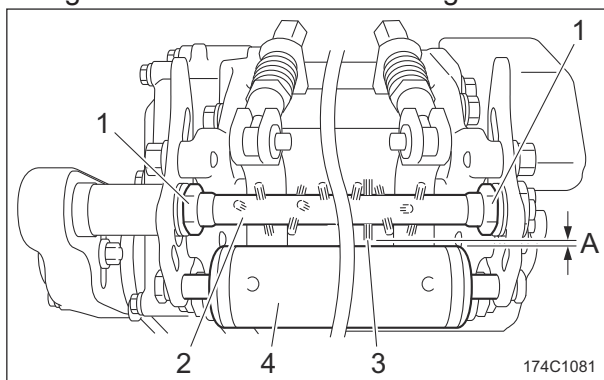

Adjustment of CR Brush_001

1	Nut
2	Brush shaft
3	Brush tip
4	Rear roller
A	0 - 1 mm (0 - 0.4 in)

Adjustment of CR Brush Drive Belt

1. Remove the belt cover.
2. Check the belt tension.

The criterion for the belt tension is that the belt slacks approximately 5 - 6 mm (0.20 - 0.24 in) when you apply a force of 10 Nm (1.0 kgf) to the belt at the middle point between the reel shaft pulley and driving pulley.

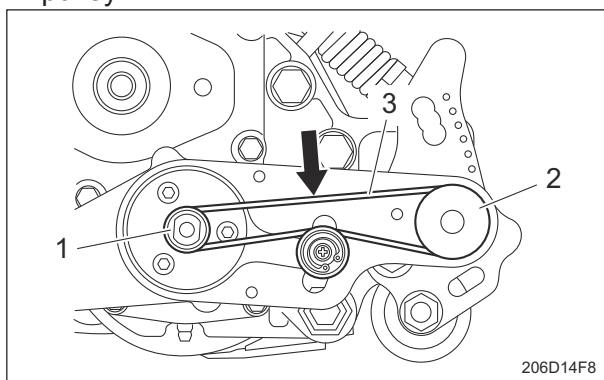

Adjustment of CR Brush Drive Belt_001

1	Reel shaft pulley
2	Driving pulley
3	Belt

3. If the belt tension is not at the approximate value, follow the steps below to adjust it.

[1] Loosen the nut so the tension pulley can be moved.

[2] Move the tension pulley in the direction of the arrow so that the slack in the belt is at the approximate value.

- [3] Tighten the nut so the tension pulley cannot be moved.

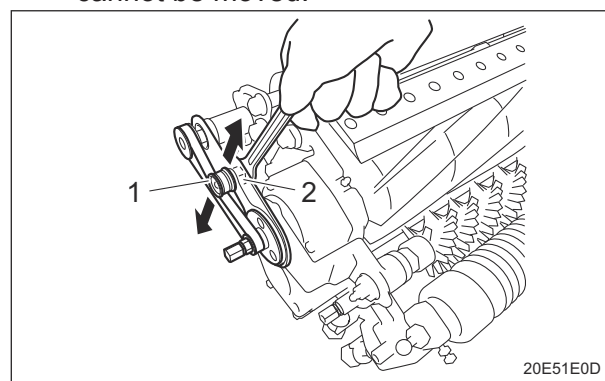

Adjustment of CR Brush Drive Belt_002

1	Tension pulley
2	Nut

4. Install the belt cover.

Adjustment of Rear Scraper (Wire Type)

Note:

Depending on the specifications, this function may not be available.

Important

Do not place the scraper in contact with the rear roller too tightly. It will cause the scraper break and slack.

1. Loosen the left and right lock nuts and nuts of the scraper.
2. Adjust the scraper so that there is a clearance of 2.0 to 3.0 mm (0.079 to 0.118 in) between it and the rear roller, and then secure it with the lock nuts.

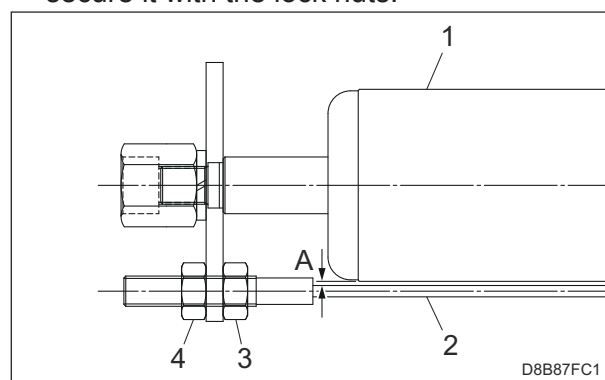

Adjustment of Rear Scraper (Wire Type)_001

1	Scraper
2	Rear roller
3	Nut
4	Lock nut
A	2.0 - 3.0 mm (0.079 - 0.118 in)

Maintenance

Replacement

Engine

Replacement of Engine Oil

Caution

Be careful with hot oil, which could cause burns if it contacts your skin.

Important

When you change the engine oil, be sure to drain it into a bowl and discard it in accordance with local laws and regulations.

Important

Be sure to use engine oil that is classified as API Service Grade CF or higher, with an SAE Viscosity that is appropriate for the operating environment (ambient temperature).

Important

Securely install the oil level gauge and oil filler cap.

Change the engine oil more frequently if the engine oil is contaminated and, especially, if you use the machine in dusty areas or operate the engine at high loads or in high temperatures.

1. Follow the steps below to remove the old engine oil.

[1] Start and run the engine to warm up the engine oil.

[2] With the machine on a level surface, stop the engine.

[3] Open the hood.

[4] Remove the drain plug, and then drain the old engine oil into a container.

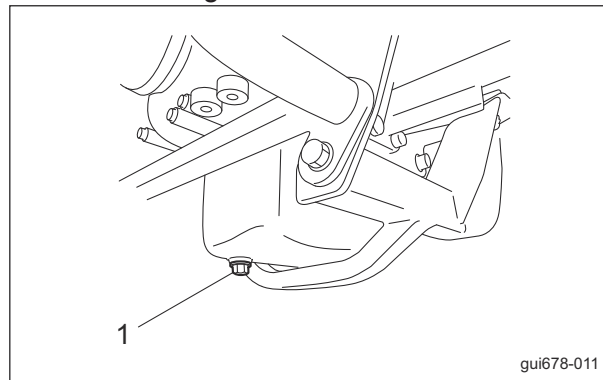

Replacement of Engine Oil_001

1	Drain plug
---	------------

[5] Install the drain plug in the engine.

2. Remove the oil filler cap, and supply new engine oil until the oil reaches a level in between the upper and lower limit lines on the oil level gauge.

Engine oil quantity is approximately 2.8 dm³ (2.8 L).

3. Install the oil filler cap.

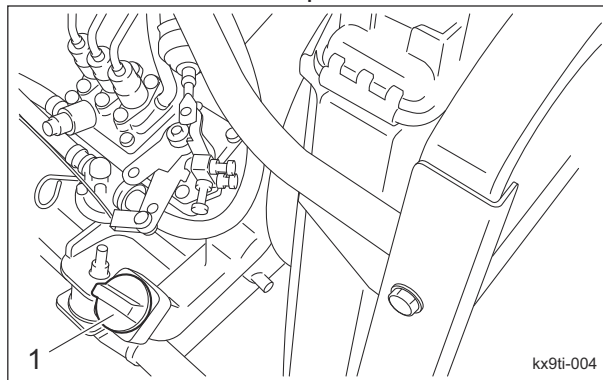

Replacement of Engine Oil_002

1	Oil filler cap
---	----------------

4. It will take a while for the supplied engine oil to descend into the oil pan.

Check the oil level again 10 to 20 minutes after filling the oil.

5. Check underneath the machine for oil leakage.

6. Close the hood.

Replacement of Engine Oil Filter

Caution

Be careful with hot oil, which could cause burns if it contacts your skin.

Important

When replacing the engine oil filter, be sure to drain the engine oil into a container and discard it in accordance with local laws and regulations.

Important

Be sure to use engine oil that is classified as API Service Grade CF or higher, with an SAE Viscosity that is appropriate for the operating environment (ambient temperature).

Important

Securely install the oil level gauge and oil filler cap.

1. With the filter wrench, remove the old filter cartridge.

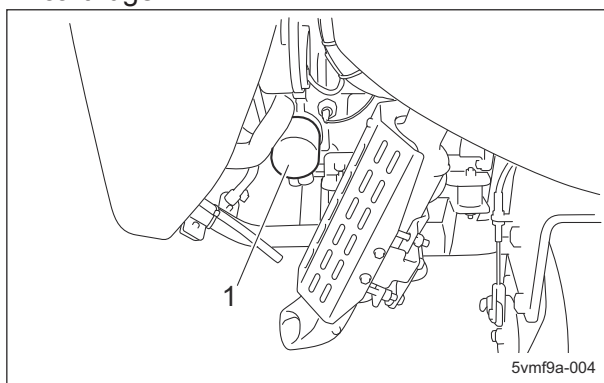

Replacement of Engine Oil Filter_001

1	Filter cartridge
---	------------------

2. Lightly coat the packing of the new filter cartridge with engine oil.
3. Hand-tighten the filter cartridge until the packing contacts the mounting surface, and then hand-tighten additional 1/2 turn.
4. Supply engine oil until it reaches the specified level.
"Supply of Engine Oil" (Page 6-7)
5. Start the engine, and then stop it after 10 to 20 minutes.

6. Make sure that there is no oil leakage at the sealing surface of the filter cartridge.
7. Check the engine oil level.
If it is low, supply engine oil until it reaches the specified level.
8. Check underneath the machine for oil leakage.

Replacement of Fuel Filter Element

Replace the fuel filter element according to the maintenance schedule.
The fuel filter is on the left side under the fuel tank.

1. Close the fuel cock of the fuel filter.

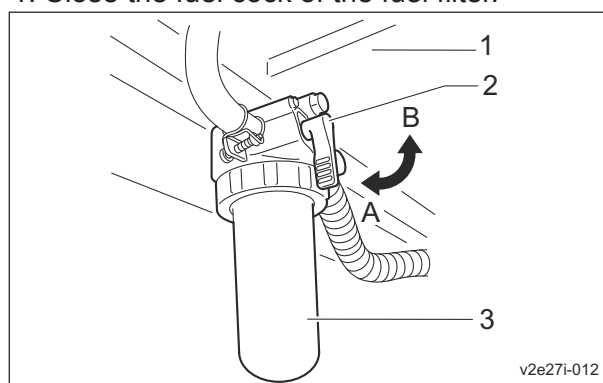

Replacement of Fuel Filter Element_001

1	Fuel tank
2	Fuel cock
3	Fuel filter
A	ON (open)
B	OFF (close)

2. Remove the ring nut, and then remove the cup.

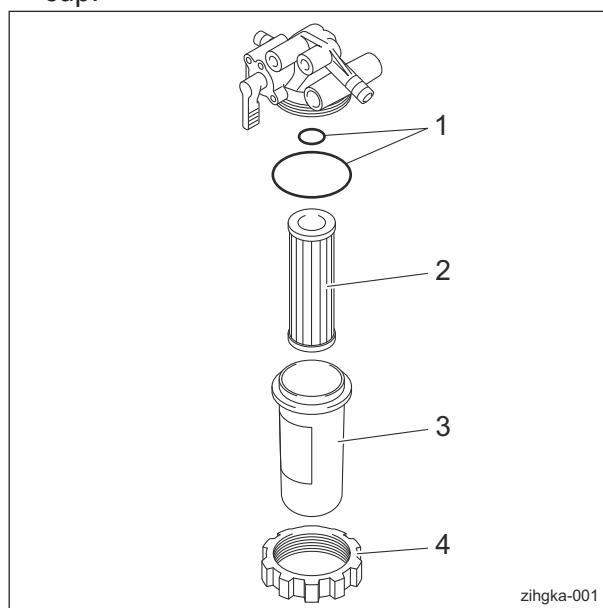

Replacement of Fuel Filter Element_002

Maintenance

1	O-ring
2	Element
3	Cup
4	Ring nut

3. Clean the inside of the filter cup with diesel fuel.

Important

While installing the fuel filter, prevent contamination with dirt or dust. The fuel contaminated with dirt or dust will cause engine failure.

4. Install a new fuel filter element, and then correctly install all parts in their original positions.
5. Fill up the fuel tank with fuel, and then open the fuel cock.

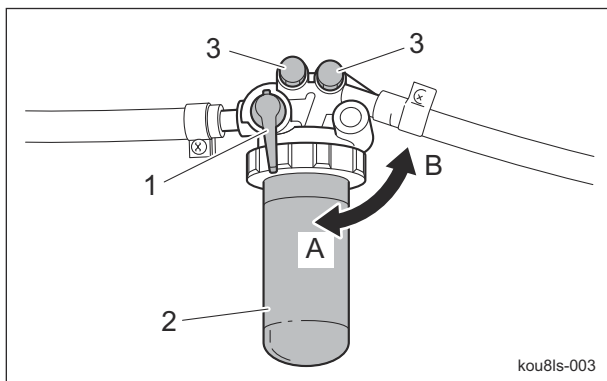

Replacement of Fuel Filter Element_003

1	Fuel cock
2	Fuel filter
3	Air-bleeding plug
A	ON (open)
B	OFF (close)

6. Remove air out of the fuel.

Replacement of Air Cleaner Element

Important

A contaminated air cleaner element may cause malfunction of the engine.

1. The timing for replacing the air cleaner element is described below.
 - [1] Replace the air cleaner element in accordance with the Maintenance Schedule.
 - [2] If it is significantly contaminated, replace it, even if the hours of operation do not exceed the specified time.
2. Replace the air cleaner element by following the same steps as for cleaning the air cleaner element. "Cleaning of Air Cleaner Element" (Page 6-4)

Replacement of Coolant

Caution

Do not touch the radiator or coolant during engine operation or immediately after the engine has been turned off. Otherwise, you may get burned due to high temperatures.

Caution

Change coolant after the engine has well cooled down.

Caution

The radiator cap is pressurized. If you remove the radiator cap while the engine is overheated, hot steam will burst out, possibly resulting in burns. Make sure that the water temperature and pressure are reduced, and then grab the cap with a thick cloth and gradually open the cap.

Important

When changing the coolant, be sure to drain it into a container and discard it in accordance with local laws and regulations.

Important

When changing the coolant, be sure to mix clean water (soft water) and antifreeze (long-life coolant), and then pour it into the radiator and reserve tank.

Important

Tightly close the radiator cap. If the cap is loose or incorrectly installed, water will leak and the engine will be damaged due to overheating.

When mixing antifreeze and clean water (soft water), refer to "Relationship between concentration of long-life coolant (LLC) and freezing temperature" below for the mixing ratio.

Relationship between concentration of long-life coolant (LLC) and freezing temperature

Freezing temperature	LLC concentration (volume %)
Down to -10 °C (14 °F)	20 %
Down to -15 °C (5 °F)	30 %
Down to -20 °C (-4 °F)	35 %
Down to -25 °C (-13 °F)	40 %

1. Stop the engine, and then allow the radiator to cool.
2. Open the radiator cover.
3. Follow the steps below to drain the coolant.
 - [1] Position a container to drain the coolant into.
 - [2] Remove the drain plug from the radiator.

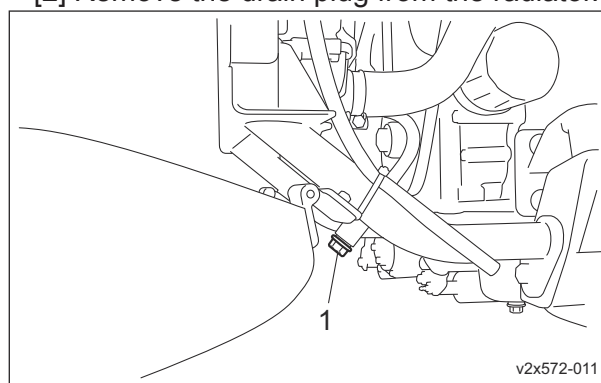

Replacement of Coolant_001

- | | |
|---|---------------------|
| 1 | Radiator drain plug |
|---|---------------------|

- [3] Remove the radiator cap and drain the coolant.

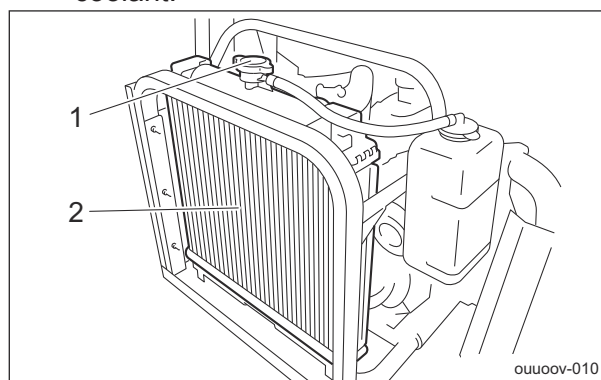

Replacement of Coolant_002

- | | |
|---|--------------|
| 1 | Radiator cap |
| 2 | Radiator |

Maintenance

[4] Remove the reserve tank.

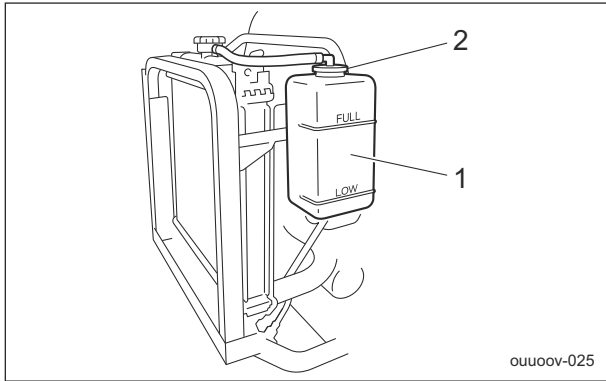

Replacement of Coolant_003

1	Reserve tank
2	Reserve tank cap

[5] Open the reserve tank cap, and then drain the coolant.

4. Install the reserve tank.
5. Clean the radiator with clean water to remove any debris or rust.
6. Drain all water from the radiator.
7. Follow the steps below to fill with coolant.
The coolant quantity, including the reserve tank, is 3.0 dm³ (3.0 L).
- [1] Install the drain plug.
- [2] Supply clean water and antifreeze into the radiator up to the radiator cap opening.
- [3] Close the radiator cap.
- [4] Supply clean water and antifreeze into the reserve tank up to the "FULL" mark.
- [5] Close the reserve tank cap.
8. Start the engine, and then idle for several minutes to bleed air from the system.
9. Stop the engine, and then allow the radiator to cool.
10. Check if the coolant level in the reserve tank is between "FULL" and "LOW", and then supply coolant if necessary.
11. Close the radiator cover.

Main Vehicle

Replacement of Hydraulic Oil

Caution

Be careful with hot oil, which could cause burns if it contacts your skin.

Caution

Change oil after the hydraulic system has been sufficiently cooled down.

Important

When you change the hydraulic oil, be sure to drain it into a bowl and discard it in accordance with local laws and regulations.

Important

If the oil emulsifies or if it becomes even slightly less transparent, change the oil immediately.

Important

For the hydraulic oil to be used, consult Characteristics of Hydraulic Oil and use the oil whose characteristics are equivalent or superior to those specified there. Especially regarding kinematic viscosity and viscosity index, use of hydraulic oil whose figures are less than those of the specified hydraulic oil will cause a malfunction in the hydraulic circuit.

■ Characteristics of Hydraulic Oil

ISO Viscosity Grade		ISO VG46
Density	15 °C (59 °F)	0.873 g/cm ³ (0.0315 lb/in ³)
API Gravity		30.6
Flash Point (Open Cup)		230 °C (446 °F)
Pour Point		-30 °C (-22 °F)
Kinematic	40 °C (104 °F)	46 mm ² /s (46 cSt)
Viscosity	100 °C (212 °F)	7 mm ² /s (7 cSt)
Viscosity Index		109

■ Characteristics of Hydraulic Oil with conditions of use

Hydraulic oil of ISO viscosity grade VG68 can be used only if the following condition is met:

- The outside temperature must be 20 °C (68 °F) or more during engine operation.

ISO Viscosity Grade		ISO VG68
Density	15 °C (59 °F)	0.878 g/cm ³ (0.0318 lb/in ³)
API Gravity		29.7
Flash Point (Open Cup)		252 °C (486 °F)
Pour Point		-30 °C (-22 °F)
Kinematic	40 °C (104 °F)	68 mm ² /s (68 cSt)
Viscosity	100 °C (212 °F)	9 mm ² /s (9 cSt)
Viscosity Index		107

Note:

In Japan, "Shell Tellus S2M46 (ISO VG46)" and "Shell Tellus S2M68 (ISO VG68)" meet the characteristics described above.

However, in other countries, the specification of Shell Tellus S2M46 and Shell Tellus S2M68 can be below what is required.

Please check the product data sheet to ensure that it meets the requirements before using.

1. Follow the steps below to remove the old oil.

- [1] Start and run the engine to warm up the oil.
- [2] Lower the mower units on a level surface, and then stop the engine.
- [3] Remove the drain plug of the hydraulic tank, and then drain the old oil into a container.
- [4] Wind new sealing tape on the drain plug, and then attach it to the hydraulic tank.

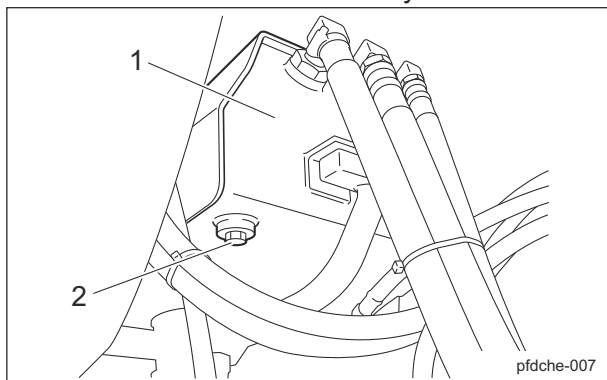

Replacement of Hydraulic Oil_001

1	Hydraulic tank
2	Drain plug

2. Open the hood.
3. Follow the steps below to supply new hydraulic oil.

[1] Open the tank cap.

[2] Supply new oil from the oil filler port until the oil level reaches the middle of the oil gauge on the hydraulic tank. The hydraulic tank capacity is approximately 16.0 dm³ (16.0 L).

[3] Tighten the tank cap securely.

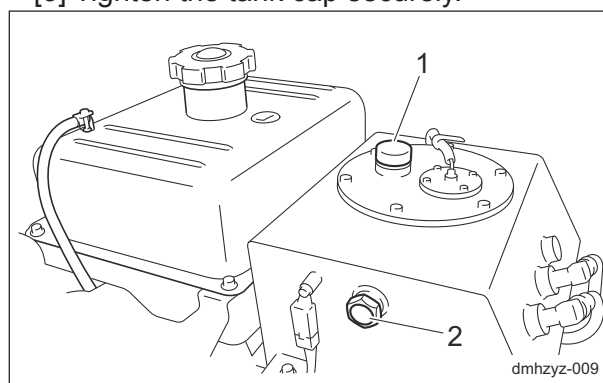

Replacement of Hydraulic Oil_002

1	Tank cap
2	Oil gauge

4. Start the engine, and then repeat the steps below a few times.
 - Raise and lower the mower units.
 - Turn the steering wheel left and right.
 - Move forward and reverse.
5. Lower the mower units and maintain that position on a level surface, and then check to see if the oil level is at the middle of the oil gauge. If the hydraulic oil level is low, supply oil again until it reaches the specified level.
6. Check underneath the machine for oil leakage.
7. Close the hood.

Maintenance

Replacement of Hydraulic Oil Filter

■ Replacement of Hydraulic Oil Line Filter

⚠ Caution

Be careful with hot oil, which could cause burns if it contacts your skin.

⚠ Caution

Change filter after the hydraulic system has been sufficiently cooled down.

Important

When replacing the hydraulic oil filter, be sure to drain the oil into a container and discard it in accordance with local laws and regulations.

Important

If the hydraulic oil emulsifies or if it becomes even slightly less transparent, change the oil immediately.

Important

Use hydraulic oil whose specification meets the requirements.

1. Lower the mower units on a level surface.
2. Stop the engine.
3. Remove the old filter cartridge.

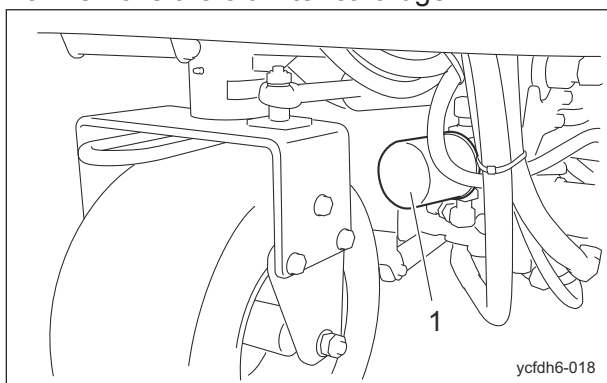

Replacement of Hydraulic Oil Line Filter_001

1 Filter cartridge

4. Lightly coat the packing of the new filter cartridge with hydraulic oil, and then install the cartridge.

5. Screw in the filter cartridge by hand until the packing contacts the mounting surface.
Then tighten additional 1/2 turn from that point.
6. Supply hydraulic oil until it reaches the specified level.
"Supply of Hydraulic Oil" (Page 6-9)
7. Start the engine, and then stop it after 10 to 20 minutes.
8. Make sure that there is no oil leakage at the sealing surface of the filter cartridge.
9. Check the hydraulic oil level.
If it is low, supply hydraulic oil until it reaches the specified level.
10. Check underneath the machine for oil leakage.

■ Replacement of Hydraulic Oil Suction Filter

⚠ Caution

Be careful with hot oil, which could cause burns if it contacts your skin.

⚠ Caution

Change filter after the hydraulic system has been sufficiently cooled down.

Important

When replacing the hydraulic oil filter, be sure to drain the oil into a container and discard it in accordance with local laws and regulations.

Important

If the hydraulic oil emulsifies or if it becomes even slightly less transparent, change the oil immediately.

Important

Use hydraulic oil whose specification meets the requirements.

Important

Replace the intake port packing with a new one.

Important

Be careful that dust does not fall into the tank when changing the filter. Otherwise, it will damage the hydraulic system.

1. Lower the mower units on a level surface.
2. Stop the engine.
3. Open the hood.
4. Remove the bolts, spring washers (- #32434) and washers, and then remove the hydraulic tank cap.
5. Remove the old suction filter and packing.
6. Remove all of the old liquid gasket from the hydraulic tank.
7. Remove all of the old liquid gasket and the packing from the hydraulic tank cap.
8. Wash and clean the hydraulic tank cap.

9. Apply liquid gasket to a new packing and then install it to the hydraulic tank cap.
10. Install the new suction filter to the hydraulic tank cap.
11. Install the hydraulic tank cap.

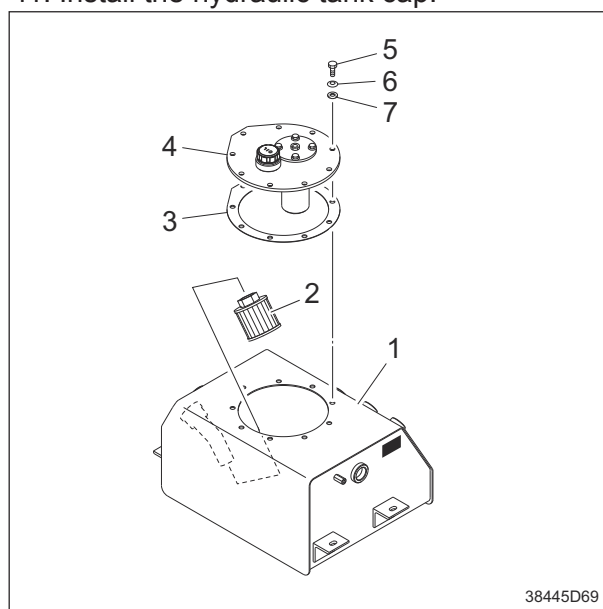

38445D69

Replacement of Hydraulic Oil Suction Filter_001

1	Hydraulic tank
2	Suction filter
3	Packing
4	Hydraulic tank cap
5	Bolt
6	Spring washer (-#32434)
7	Washer

12. Supply hydraulic oil until it reaches the specified level.
"Supply of Hydraulic Oil" (Page 6-9)
13. Start the engine, and stop it after hydraulic oil has been warmed up.
14. Check underneath the machine for hydraulic oil leakage.
15. Close the hood.

Maintenance

Replacement of Transmission Grease

The transmission is located behind the driver's seat.
Change grease every two years.

Grease type	Pyronoc CC1
Grease quantity	400 g (14.11 oz)

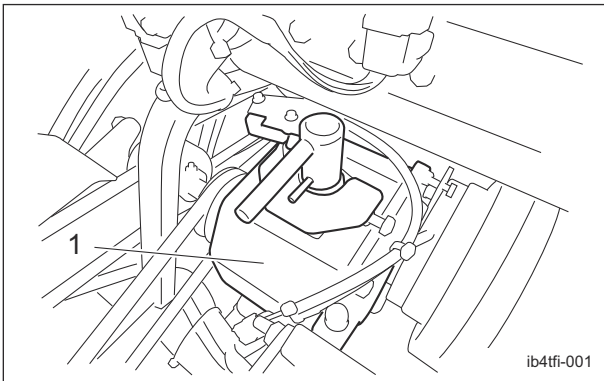

Replacement of Transmission Grease_001

1	Transmission
---	--------------

Replacement of Tires

■Replacement of Front Tires

1. Removing front tires

Follow the steps below to remove the front tire:

[1] Loosen the bolts.

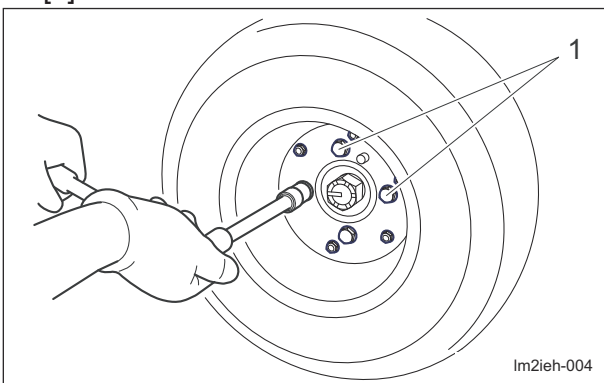

Replacement of Front Tires_001

1	Bolt
---	------

[2] Securely place the jack beneath the jack-up point of the front left and right frame area, and then raise it until the tire lifts off the ground.

[3] Remove the bolts.

[4] Remove the tire from the wheel mounting base.

2. Installing front tires

Important

Tighten the bolts in the tightening order (crosswise).

Important

Tighten the wheel mounting bolts on the specified torque by using a torque wrench.

For installing the front tires, reverse the removing procedure.

■Replacement of Rear Tire

1. Removing the rear tire from the 2WD machine

Follow the steps below to remove the rear tire from the 2WD machine:

[1] Securely place the jack beneath the jack-up points of the engine mount frame area, and then raise it until the tire lifts off the ground.

"Jack-Up Points" (Page 6-3)

[2] Remove the wire.

[3] Remove the right/left bolts.

[4] Remove the rear wheel Assy.

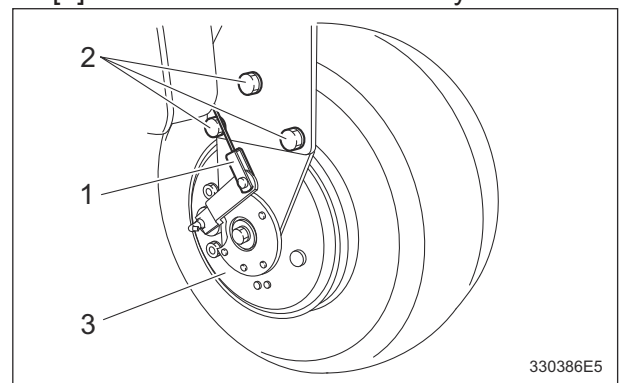

Replacement of Rear Tire_001

1	Wire
2	Bolt
3	Rear wheel Assy

[5] Remove the bolts.

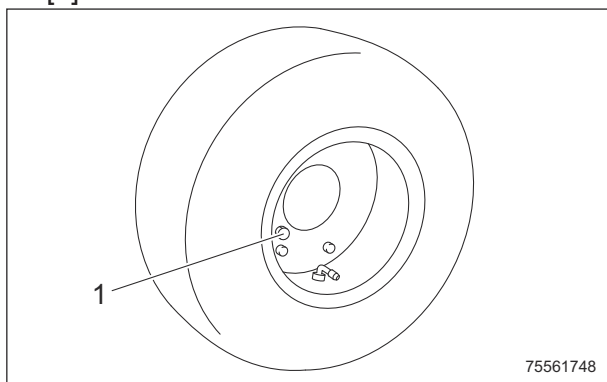

75561748

Replacement of Rear Tire_002

1	Bolt
---	------

[7] Remove the bolts.

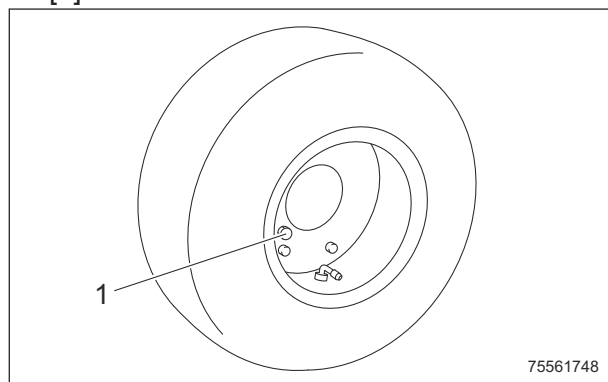

75561748

Replacement of Rear Tire_004

1	Bolt
---	------

[6] Remove the tire from the wheel mounting base.

2. Removing the rear tire from the 3WD machine

Follow the steps below to remove the rear tire from the 3WD machine:

[1] Securely place the jack beneath the jack-up points of the engine mount frame area, and then raise it until the tire lifts off the ground.
"Jack-Up Points" (Page 6-3)

[2] Remove the wire.

[3] Remove right/left the bolt A(s).

[4] Remove the bolt B at the center.

[5] Remove the brake shoe Assy.

[6] Remove the brake drum.

[8] Remove the tire from the wheel mounting base.

3. Installing the rear tire

Important

Tighten the bolts in the tightening order (crosswise).

Important

Tighten the wheel mounting bolts on the specified torque by using a torque wrench.

For installing the rear tires, reverse the removing procedure.

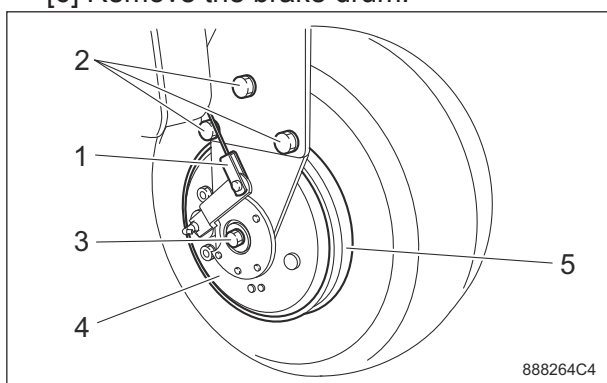

888264C4

Replacement of Rear Tire_003

1	Wire
2	Bolt A
3	Bolt B
4	Brake shoe Assy
5	Brake drum

Maintenance

Mower Unit

Replacement of Reel Cutter (Cutting Cylinder)

Caution

Both the reel cutter (cutting cylinder) and the bed knife (bottom blade) are edged tools. Handle them carefully, since they could cut your hands and feet.

Caution

Wear gloves when touching edged tools to avoid cutting your hands.

The criteria for replacing the reel cutter (cutting cylinder) are described below. However, these criteria are only a reference and do not guarantee performance like that of a new reel cutter (cutting cylinder).

1. When the outer diameter of the reel cutter (cutting cylinder) is less than the usage limit

New		Usage limit	
Dimension A (Outer diameter of reel cutter (cutting cylinder))	Dimension B (Distance from blade edge to outer edge of reel cutter (cutting cylinder) shaft)	Dimension A (Outer diameter of reel cutter (cutting cylinder))	Dimension B (Distance from blade edge to outer edge of reel cutter (cutting cylinder) shaft)
128 mm (5.04 in)	51.3 mm (2.02 in)	118 mm (4.65 in)	46.3 mm (1.82 in)

Note:

The outer diameter of the reel cutter (cutting cylinder) shaft is 25.4 mm (1.00 in).

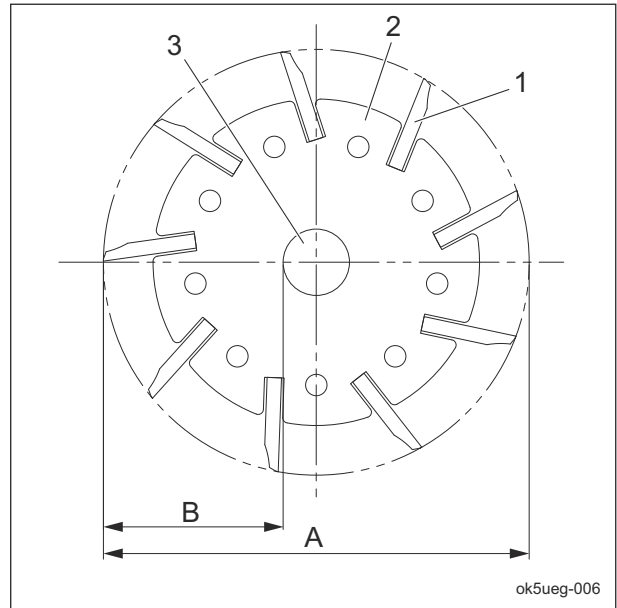

Replacement of Reel Cutter (Cutting Cylinder)_001

1	Reel cutter (cutting cylinder) blade
2	Reel cutter (cutting cylinder) disc
3	Reel cutter (cutting cylinder) shaft
A	Outer diameter of reel cutter (cutting cylinder)
B	Distance from blade edge to outer edge of reel cutter (cutting cylinder) shaft

■ Procedure to Install Reel Cutter (Cutting Cylinder)

Caution

Both the reel cutter (cutting cylinder) and the bed knife (bottom blade) are edged tools. Handle them carefully, since they could cut your hands and feet.

Caution

When handling the reel cutter (cutting cylinder) or bed knife (bottom blade), wear gloves to protect your hands. Pay attention not to let the reel cutter (cutting cylinder) catch your gloves. Otherwise, you may injure your hand or fingers.

Important

Use 30204JRP6 as bearing for the reel cutter.

1. Remove the bearings on the left and right ends of reel cutter, and the oil seal.

2. Fill up the bearings and oil seal with grease (Excelite EP No.2).
3. Attach the reel cutter (cutting cylinder) to the frame.
4. Tighten 20-tooth reel gear and check the bearing for backlash.
5. Loosen 20-tooth reel gear at the level that the reel cutter (cutting cylinder) can be rotated lightly by your hand and you don't feel the backlash.
6. Tighten 20-tooth reel gear on the specified torque again.
Tightening torque: 2.5 N-m (25.49 kgf-cm/ 22.13 lb-in)
7. Tighten the reel gear fixing nut.

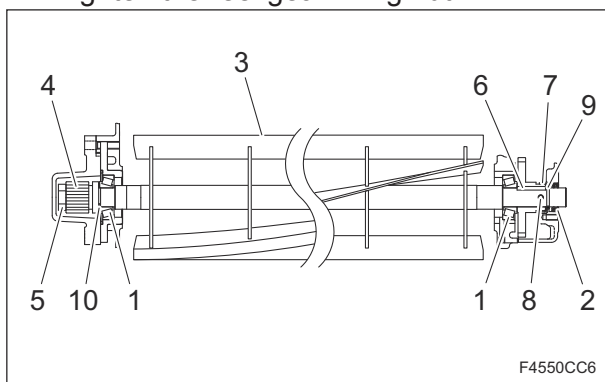

Procedure to Install Reel Cutter (Cutting Cylinder)_001

1	Bearing
2	Seal
3	Reel cutter (Cutting cylinder)
4	20-tooth reel gear
5	Reel gear fixing nut
6	Key
7	Cover
8	Pin
9	O-ring
10	Wave washer

Replacement of Bed Knife (Bottom Blade)

⚠ Caution

Both the reel cutter (cutting cylinder) and the bed knife (bottom blade) are edged tools. Handle them carefully, since they could cut your hands and feet.

⚠ Caution

Wear gloves when touching edged tools to avoid cutting your hands.

The criteria for replacing the bed knife (bottom blade) are described below.

1. When the reel cutter (cutting cylinder) is ground
2. When the reel cutter (cutting cylinder) is replaced
3. When the bed knife (bottom blade) is worn
Standard blade
Replace the bed knife (bottom blade) before it no longer has a front face.

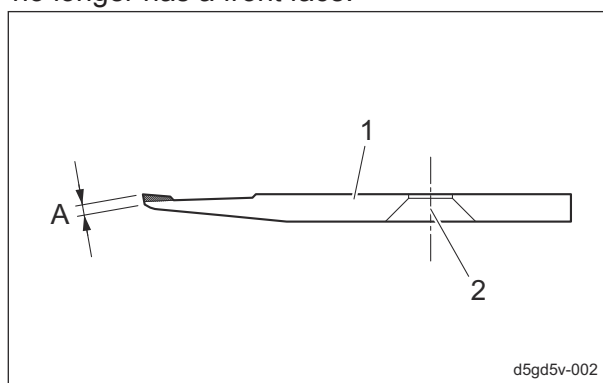

Replacement of Bed Knife (Bottom Blade)_001

1	Bed knife (bottom blade)
2	Mounting hole
A	Front face

Maintenance

High-speed-steel-tipped blade

Replace the bed knife (bottom blade) before it no longer has a tip.

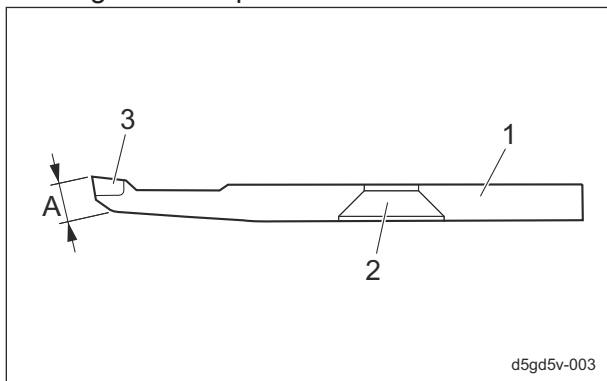

Replacement of Bed Knife (Bottom Blade)_002

1	Bed knife (bottom blade)
2	Mounting hole
3	Tip
A	Front face

Storage

Long-Term Storage

Follow the instructions below for long-term storage of the machine.

1. Cleaning

- Remove dirt, grass clippings, oil stains etc. completely from the main vehicle and engine.

2. Replacing oil

- Inspect and replace the engine oil, hydraulic oil and element.

3. Greasing and lubricating

- Supply oil and apply grease to appropriate parts.

4. Battery

- Remove the negative battery wire.

5. Fuel

- Remove the fuel from the fuel tank.

6. Tire pneumatic pressure

- Set the tire air pressure slightly higher than normal, and then place the machine on a board to avoid humidity.

7. Mower units

- When storing this machine, lower all the mower units unless a positive mechanical lock is provided.

8. Storage location

- Cover the machine and store it in a dry place where it will not be exposed to rain.

Precautions for Repair Page 7-2

Inspection Page 7-2

Inspection of The Operation Status
of The Control UnitPage 7-2

Adjustment Page 7-3

Adjustment of Parking Brake Page 7-3

Adjustment of Work Speed Page 7-3

Adjustment of The Neutral Position
of The Piston Pump Page 7-3

Replacement Page 7-4

Replacement of Flexible WirePage 7-4

Replacement of Fuse Page 7-8

TowingPage 7-9

Towing the Machine in an
EmergencyPage 7-9



Repair

Precautions for Repair

Warning

The chapter "Repair" in this manual describes practical measures which should be performed by a mechanic with expertise. The owner should instruct the mechanic with expertise to perform repair service for this machine.

Caution

First, learn well the operations you plan to perform.

Important

Use tools appropriate for each operation.

Important

Use Baroness genuine parts for replacement and accessories. Our product warranty may be void if you use non-genuine parts for replacement or accessories.

Inspection

Inspection of The Operation Status of The Control Unit

Mower Unit Control Relay

The relay box is located behind the seat. This controls Up/Down of the mower unit and Rotate/Stop of the reel cutter (cutting cylinder). The operating condition can be checked by the illumination of the LEDs.

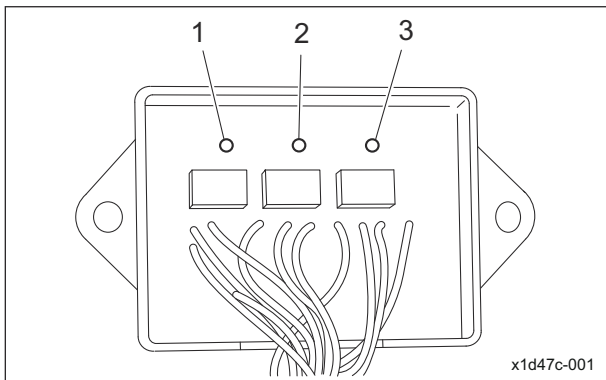

Mower Unit Control Relay_001

Refer to the table below to check the LED status.

		Condition	LED status
1	Front right up/down cylinder (Reel rotation)	Down	ON
		Up	OFF
2	Center mower up/down cylinder (Before pressing Raise/Lower switch)	Up	ON
		Down	OFF
3	Center mower up/down cylinder (After pressing Raise/Lower switch)	Down	ON
		Up	OFF

Interlock Relay

The relay box is located under the underseat cover. This controls a safety device for starting/stopping the engine. The operating condition can be checked by the illumination of the LEDs.

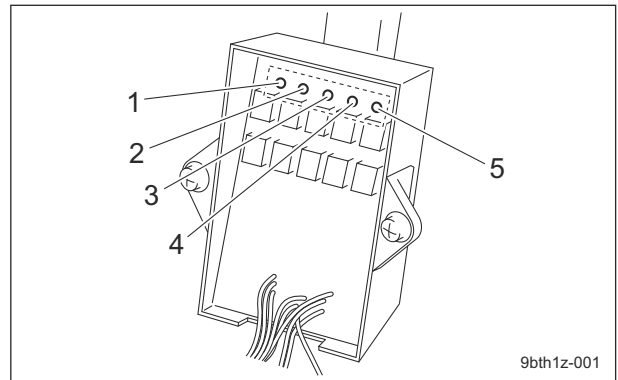

Interlock Relay_001

Refer to the table below to check the LED status.

		Condition	LED status
1	Traveling pedal switch	Neutral	ON
		Depress	OFF
2	Parking brake switch	Pull	ON
		Release	OFF
3	Seat switch	Away	ON
		Seated	OFF
4	Reel rotation switch	ON	ON
		OFF	OFF
5	Transmission selector lever	LAP	ON
		H	OFF
		L	OFF

Adjustment

Adjustment of Parking Brake

⚠ Caution

If the brake wire is cut, the machine will be unable to stop.
If the brake wire is cracked or damaged, replace it with a new one immediately.

Important

Make sure that the brake is effective on slopes and that it is not applied any longer when you release it.
Adjust the parking brake system whenever there is any abnormality.

- Adjust the parking brake by tightening the brake wire adjustment bolt.
Adjust the parking brake so that it is in the following conditions.
 - Brake applies when the parking brake lever is pulled.
 - The brake shoe does not touch the brake drum when the parking brake lever is released.

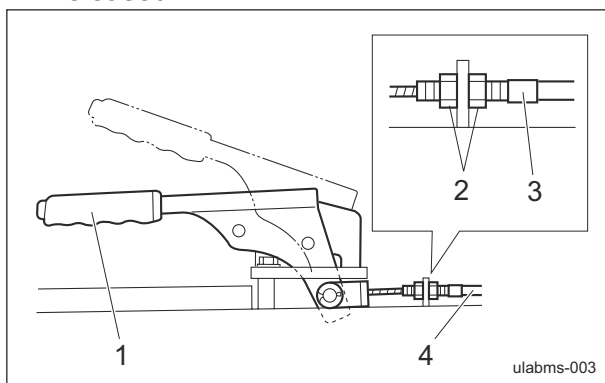

Adjustment of Parking Brake_001

1	Parking brake lever
2	Lock nut
3	Adjustment bolt
4	Brake wire

- After adjusting the parking brake, check the following.
 - Make sure that the brake applies when the parking brake lever is pulled.
 - Make sure that the heat is not generated in the brake area while traveling the machine.

Adjustment of Work Speed

- Lower the mower units.
- Loosen the locknut on the side of the rod head for the right cylinder.
- Adjust the length of the bolt.
 - Length of the bolt (Longer): Slower
 - Length of the bolt (Shorter): Faster
- Once the adjustment has completed, be sure to lock with the nut.

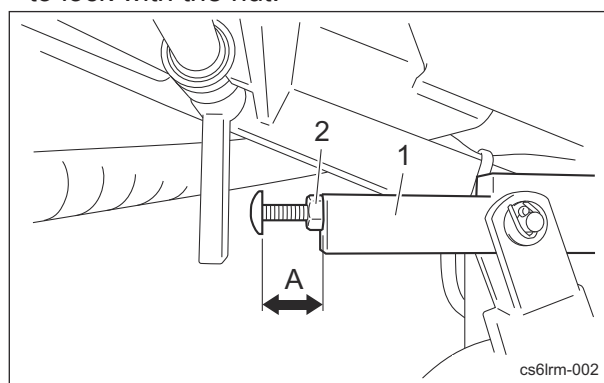

Adjustment of Work Speed_001

1	Rod head
2	Lock nut
A	Length of the bolt

Adjustment of The Neutral Position of The Piston Pump

⚠ Caution

Make sure not to touch rotating tires.

⚠ Caution

When adjusting the neutral position, pay close attention to abrupt start of the machine.
Place the jacks beneath the jack-up points, and then lift the machine until all the tires get off the ground.

- If the machine moves forward or backward while the traveling pedals are released, they are not set to the neutral position.
Follow the steps below to make adjustments.
- Stop the engine.
 - Place the jacks beneath the jack-up points, and then lift the machine off the ground.
"Jack-Up Points" (Page 6-3)
 - Make sure that no tires get contact with the jack stand.

Repair

4. Start the engine, and rev it up to the maximum rpm.
5. Adjust the neutral position.
 - [1] Loosen the lock nut.
 - [2] Rotate the camshaft slowly until the front wheel stops.
 Find the position where the front wheel stops and lock the camshaft with the nut.

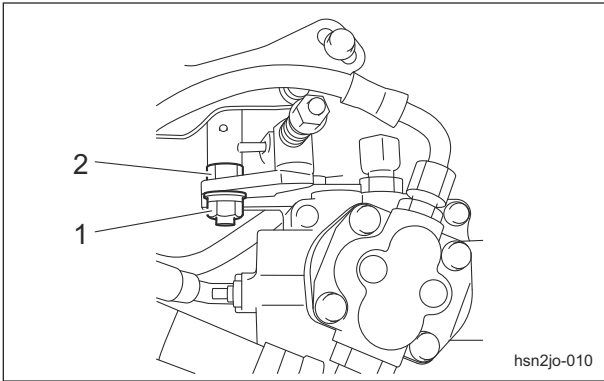

Adjustment of The Neutral Position of The Piston Pump_001

1	Lock nut
2	Cam shaft

Replacement

Replacement of Flexible Wire

Procedure to Remove Flexible Wire

1. Remove the flexible wire clammer.

Wire clammers are installed in the following locations.

 - Front mower units
 - #2: There is one point.
 - #3: There are two points.

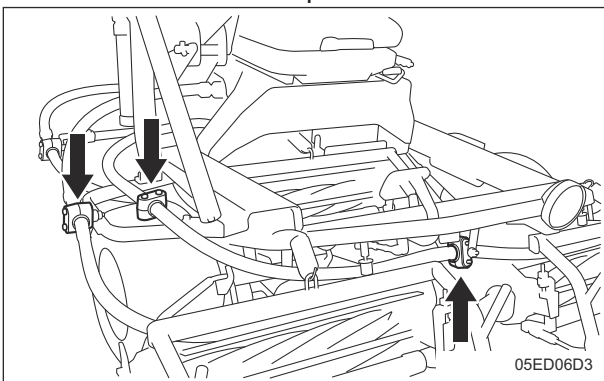

Procedure to Remove Flexible Wire_001

- Rear mower unit
 - #1: There are two points.

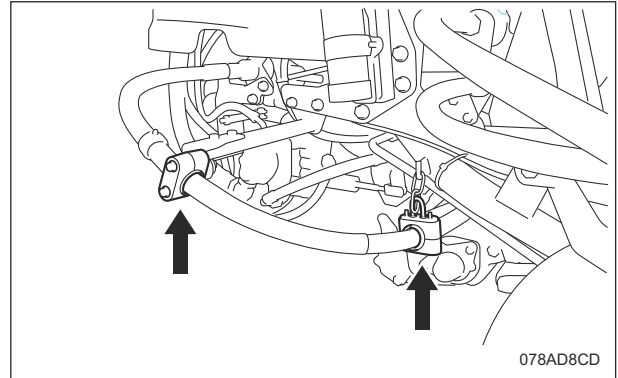

Procedure to Remove Flexible Wire_002

- [1] Loosen the bolt.
- [2] Remove the wire clammer.
- [3] Remove the rubber plate.

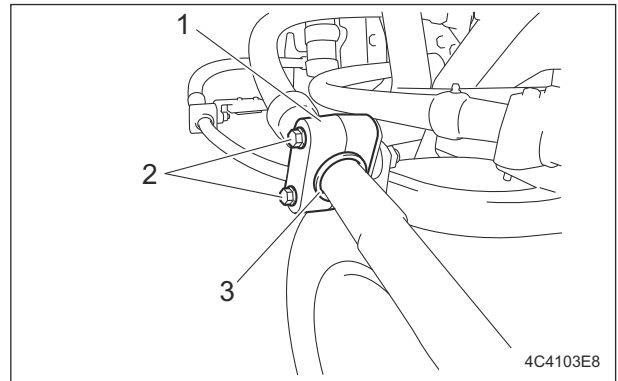

Procedure to Remove Flexible Wire_003

1	Wire clammer
2	Bolt
3	Rubber plate

2. Remove the flexible wire on the mower unit side.
 - [1] Loosen the lock nut.
 - [2] Loosen the bolt.
 - [3] Remove the clip.
 - [4] Remove the flexible wire.

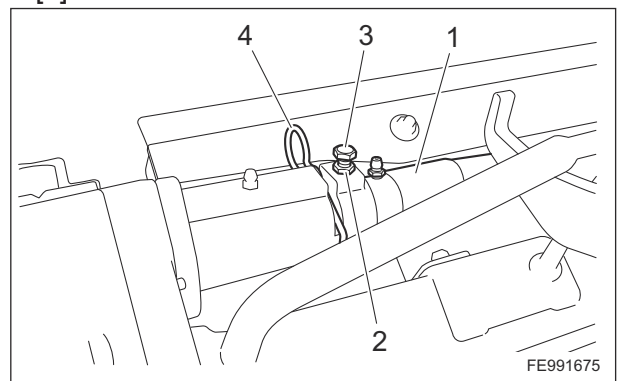

Procedure to Remove Flexible Wire_004

1	Flexible wire
2	Lock nut
3	Bolt
4	Clip

3. Remove the flexible wire on the main vehicle side.

[1] Remove the nut from the housing.

[2] Remove the flexible wire.

· Front mower unit (#2 · #3)

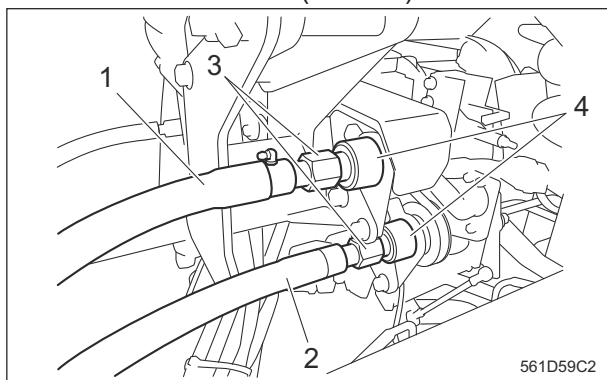

Procedure to Remove Flexible Wire_005

1	Flexible wire (#2)
2	Flexible wire (#3)
3	Nut
4	Housing

· Rear mower unit (#1)

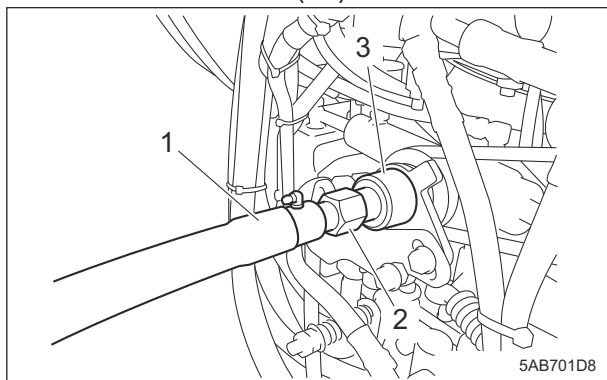

Procedure to Remove Flexible Wire_006

1	Flexible wire (#1)
2	Nut
3	Housing

Procedure to Install Flexible Wire

Important

The unsuitable air gap of the electromagnetic clutch may cause damage to the flexible wire.

1. Apply grease to the flexible wire inner edge and the inside of the housing.

Use Moly speed grease No.2.

· Flexible wire inner edge

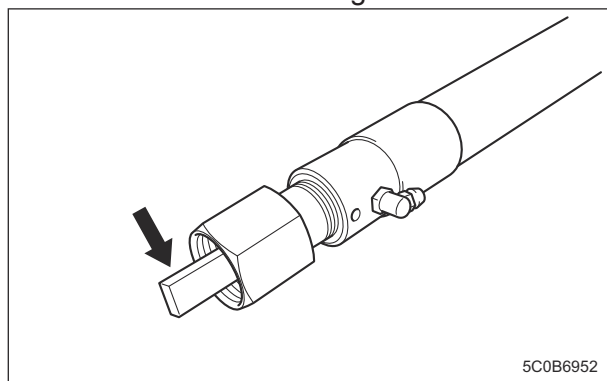

Procedure to Install Flexible Wire_001

· Inside of the housing (Main vehicle side)

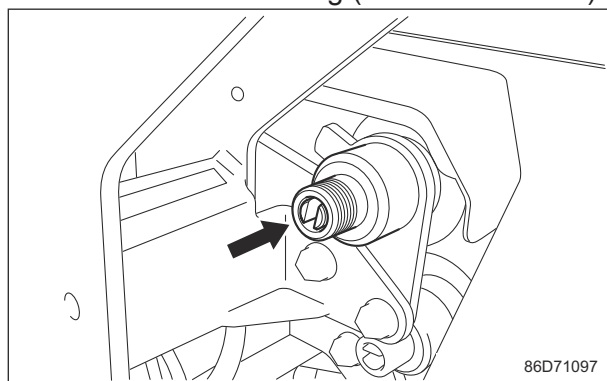

Procedure to Install Flexible Wire_002

2. Install the flexible wire on the main vehicle side.

[1] Insert the flexible wire into the housing.

[2] Tighten the nut to secure the wire.

• Front mower unit (#2 · #3)

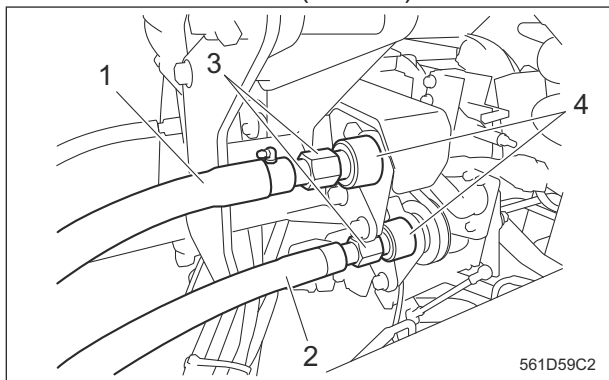

Procedure to Install Flexible Wire_003

1	Flexible wire (#2)
2	Flexible wire (#3)
3	Nut
4	Housing

• Rear mower unit (#1)

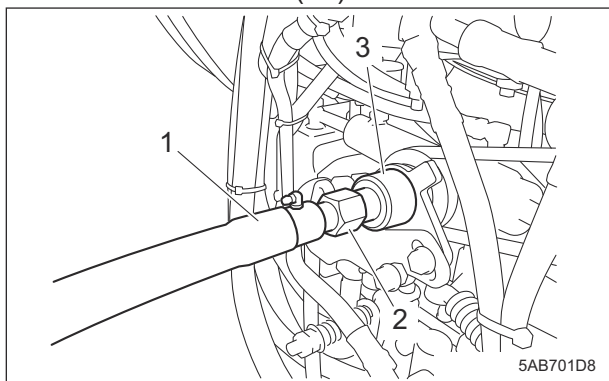

Procedure to Install Flexible Wire_004

1	Flexible wire (#1)
2	Nut
3	Housing

3. Apply grease to the flexible wire inner edge and the inside of the housing.
 Use Moly speed grease No.2.

• Flexible wire inner edge

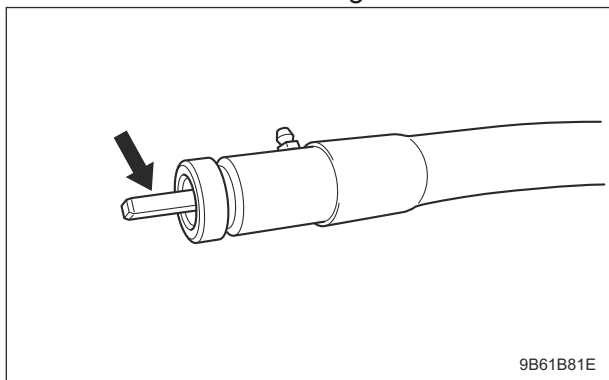

Procedure to Install Flexible Wire_005

• Inside of the housing (Mower unit side)

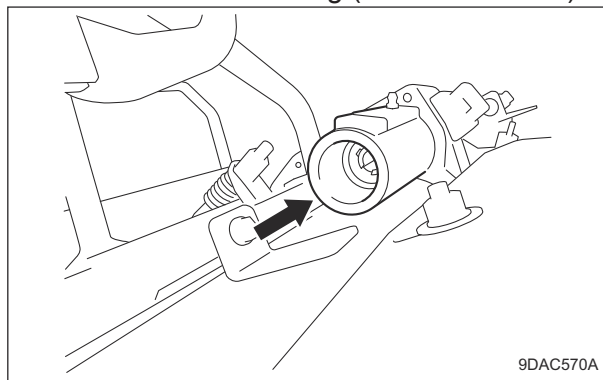

Procedure to Install Flexible Wire_006

4. Install the flexible wire on the mower unit side.

- [1] Insert the flexible wire into the housing.
- [2] Install the clip.
- [3] Tighten the bolt.
- [4] Fix it with the lock nut.

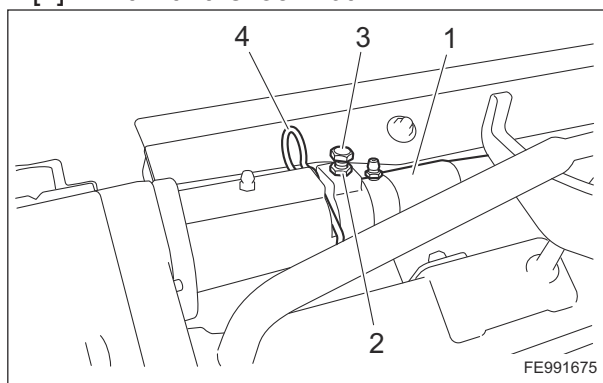

Procedure to Install Flexible Wire_007

1	Flexible wire
2	Lock nut
3	Bolt
4	Clip

5. Install the flexible wire clamber.

- [1] Make sure that the flexible wire does not have forced bends.
- [2] Wind the rubber plate on the wire.
- [3] Tighten the bolt temporarily to install the wire clamber.

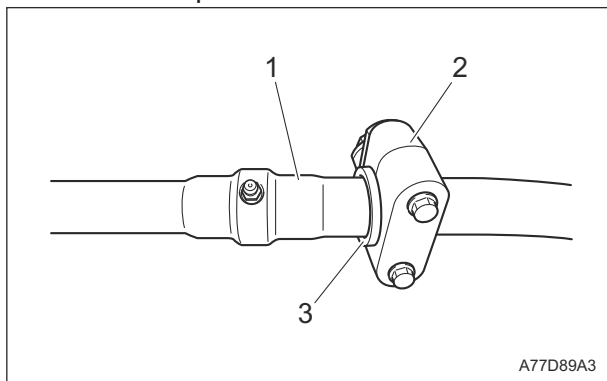

Procedure to Install Flexible Wire_008

1	Flexible wire
2	Wire clamber
3	Rubber plate

6. Adjust the position of the wire clamber.
Wire clammers are located in the following locations, and the adjustments vary depending on the location.

- Front mower unit (#2 · #3)

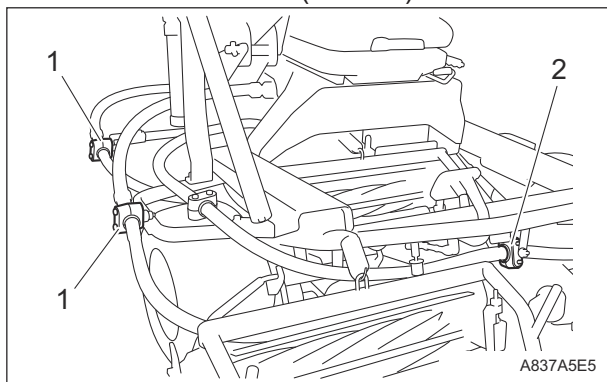

Procedure to Install Flexible Wire_009

1	Wire clamber A
2	Wire clamber B

- Rear mower unit (#1)

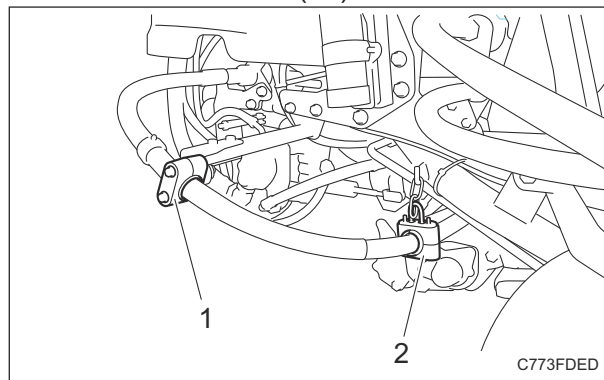

Procedure to Install Flexible Wire_010

1	Wire clamber A
2	Wire clamber C

The adjustment of the wire clammers is described below.

[1] Wire clamber: A

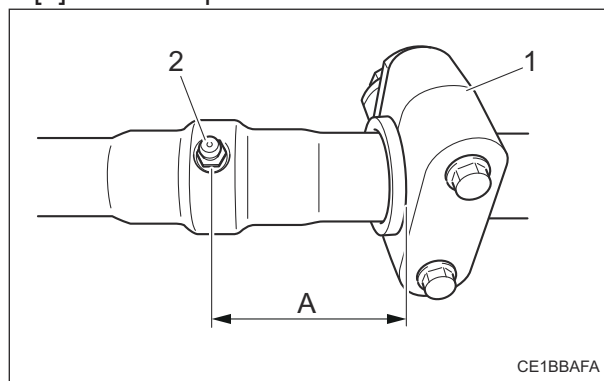

Procedure to Install Flexible Wire_011

1	Wire clamber A
2	Grease nipple
A	60 mm (2.36 in)

[2] Wire clamber: B

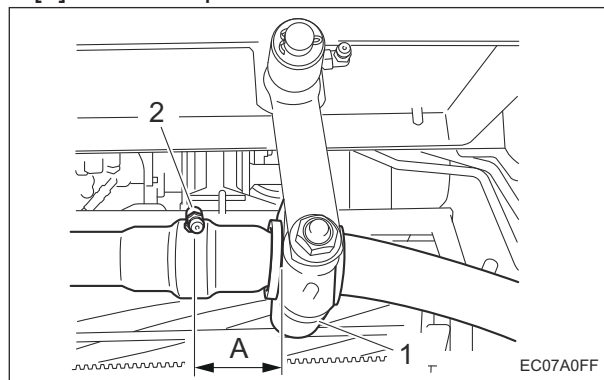

Procedure to Install Flexible Wire_012

1	Wire clamber B
2	Grease nipple
A	40 mm (1.57 in)

Repair

[3] Wire clamber: C

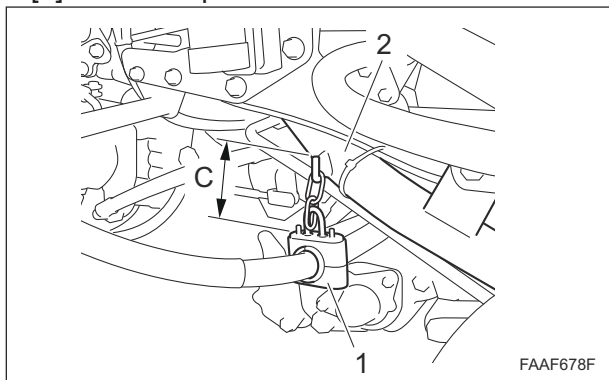

Procedure to Install Flexible Wire_013

1	Wire clamber C
2	Wire mounting bracket
C	Vertical

7. After adjustment of the flexible wire clamber position, tighten and secure the bolts.

Replacement of Fuse

Important

When performing maintenance on the electrical system, be sure to remove the negative battery wire.

Important

If a fuse blows, a short may have occurred within the electrical circuit. Check for the cause, such as faulty terminal connections, damaged wiring or terminals, or incorrect wiring.

Important

For fuse replacement, clean the fuse mounting area with use of compressed air before mounting the fuse.

Fuse

The light harness fuse is located under the underseat cover.

■ #31396 - 31818

It is a glass fuse 20 A (φ6.4 x 30 mm).

■ #31819-

It is a mini blade fuse 20 A.

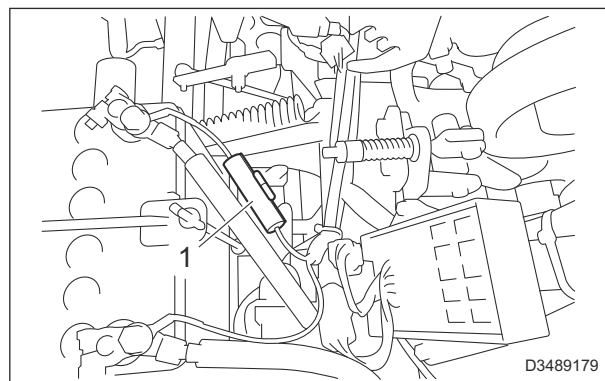

Fuse_001

1	Light harness fuse
---	--------------------

Fuse Box

The fuse box includes spare fuses and tools.

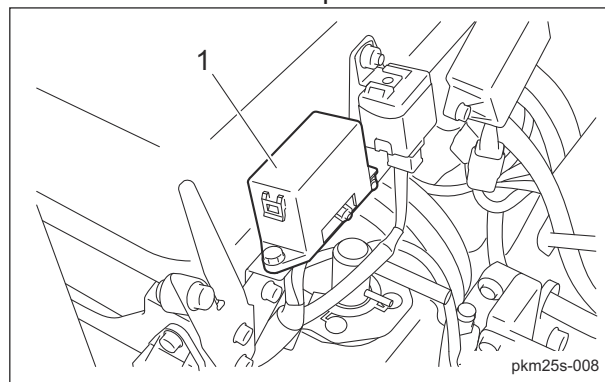

Fuse Box_001

1	Fuse box
---	----------

The machine uses a mini fuse for automobiles.
Replace an old fuse with a new fuse of the specified capacity.

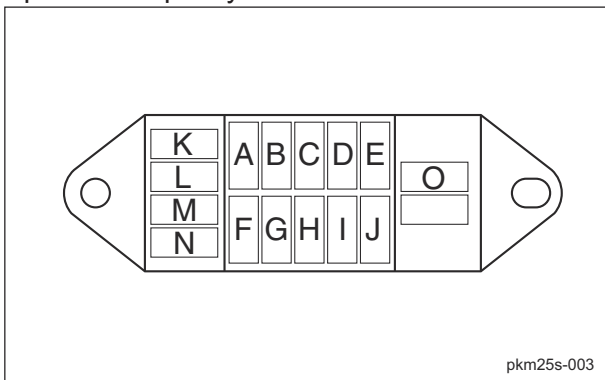

Fuse Box_002

A	5 A	Glow lamp timer
B	5 A	Key stop timer
C	5 A	Glow lamp timer, glow lamp (thermo-start lamp)
D	-	-
E	-	-
F	15 A	Engine stop solenoid
G	15 A	Others
H	5 A	Water temperature gauge, regulator
I	-	-
J	-	-
K	5 A	Spare
L	5 A	
M	15 A	
N	15 A	
O		Fuse removal tool

Fusible Link

Fuse capacity of the fusible link is 50A.

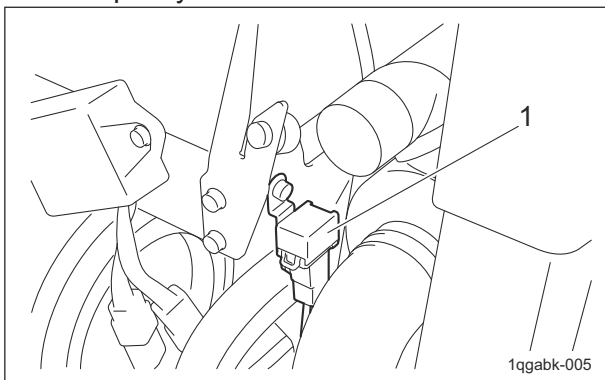

Fusible Link_001

1	Fusible link
---	--------------

Towing

Towing the Machine in an Emergency

If the machine does not travel due to engine trouble, etc., you can move it in the following ways:

- Pushing by hand
- Towing (See the following instruction.)

⚠ Caution

Do not tow on slopes.

Important

Do not touch the unload valve except when towing the machine.

Important

Before restarting the engine, be sure to close the bypass.

Important

When towing the machine, obey the following restrictions.

Obey the speed and the time restrictions to prevent damaging the pump or motor.

- Speed: Do not travel at a speed more than 3.0 km/h.
- Time: Do not tow the machine for more than 3 minutes.

When towing the machine for more than 3 minutes, start the engine and circulate the hydraulic oil in the hydraulic circuit.

Therefore, do not tow the machine until restart the engine after completed repairs.

1. Stop the engine.
"Procedure to Stop Engine" (Page 5-14)
2. Apply the parking brake.
3. Choke the wheels.
4. Secure the machine with ropes.
 - Front part of the machine: Use tow hooks on the left and right side of the frame.

Repair

Left side

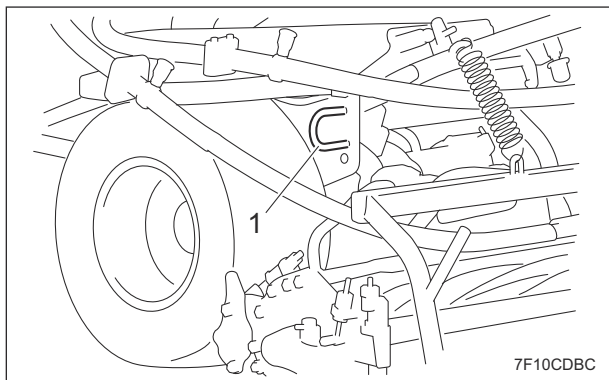

Towing the Machine in an Emergency_001

Right side

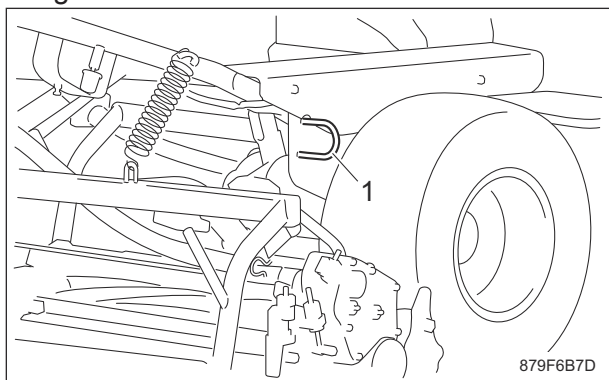

Towing the Machine in an Emergency_002

Important

When using the tow hook on the rear wheel part to tow the machine, you cannot steer the machine. The tow hook on the rear part of the machine should be used only when the tow hook on the front part cannot be used.

• Rear part of the machine :

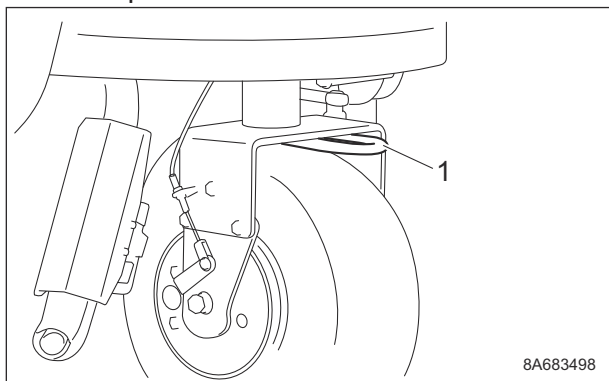

Towing the Machine in an Emergency_003

5. Open the bypass. While pressing the unload valve, rotate it 90 degrees (vertically) to set to the "Unload" position.

Note:

The unload valve is located at the lower right of the frame.

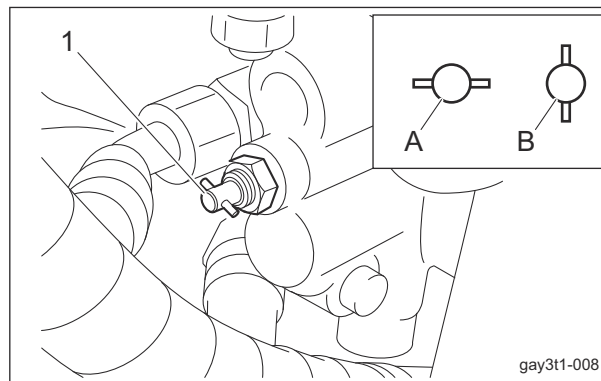

Towing the Machine in an Emergency_004

1	Unload valve
A	Onload
B	Unload

6. Remove the wheel stopper.
7. Release the parking brake.
8. Tow the machine slowly.
9. After towing is completed, close the bypass. While pressing the unload valve, rotate it 90 degrees (horizontally) to set it to the "Onload" position.

Appended Table

Tightening TorquesPage 8-2
 Standard Tightening TorquesPage 8-2
 Principal Tightening Torques Page 8-5

Daily Check List Page 8-7

Maintenance Schedule Page 8-9

List of Adjusted Values Page 8-14

Appended Table

Appended Table

Tightening Torques

Important

Refer to the Tightening Torque table.
Note that the Baroness product warranty may not apply to defects caused by incorrect or overtorque tightening, etc.

Standard Tightening Torques

Bolts and Nuts



Important

A number of bolts are used in each part of this machine.
Be sure to re-tighten the bolts and nuts, because they may be loosened at the earlier stage of the use.

- As to the bolts and nuts without any special instruction, tighten them in appropriate tightening torque with proper tool.
Too much tightening may cause the looseness or damage of the screw.
- The strength of tightening is determined by types of screws, strength, the friction of thread face or base face and others.
The table below is for the galvanized or parkerized bolts.
In case that the strength of internal thread is weak, it is not applied.
- Do not use rusty or sand attached "screw."
Otherwise, it may cause insufficient tightening even if you apply the specified tightening torque.
The friction of the screw face becomes higher and the tightening torque is canceled out by the friction, therefore sufficient tightening cannot be applied.
- If "screw" is wet by water or oil, do not tighten it with normal tightening torque.
If the screw is wet, the torque coefficient will get smaller and it may result in too much tightening.
Too much tightening may cause looseness by the screw stretched or result in damage.
- Do not use a bolt experienced too much burden.
- Using the impact wrench requires the skill.
Do exercise as much as possible for steady tightening.

Appended Table

Nominal diameter	General bolt		
	Strength classification 4.8		
	 tib3yb-001		
	N-m	kgf-cm	lb-in
M5	3 - 5	30.59 - 50.99	26.55 - 44.26
M6	7 - 9	71.38 - 91.77	61.96 - 79.66
M8	14 - 19	142.76 - 193.74	123.91 - 168.17
M10	29 - 38	295.71 - 387.49	256.68 - 336.34
M12	52 - 67	530.24 - 683.20	460.25 - 593.02
M14	70 - 94	713.79 - 958.52	619.57 - 831.99
M16	88 - 112	897.34 - 1142.06	778.89 - 991.31
M18	116 - 144	1,182.85 - 1,468.37	1,026.72 - 1,274.54
M20	147 - 183	1,498.96 - 1,866.05	1,301.10 - 1,619.73
M22	295	3,008.12	2,611.05
M24	370	3,772.89	3,274.87
M27	550	5,608.35	4,868.05
M30	740	7,545.78	6,549.74

Nominal diameter	Heat-treated bolt					
	Strength classification 8.8			Strength classification 10.9		
	 tib3yb-002			 tib3yb-003		
	N-m	kgf-cm	lb-in	N-m	kgf-cm	lb-in
M5	5 - 7	50.99 - 71.38	44.26 - 61.96	7 - 10	71.38 - 101.97	61.96 - 88.51
M6	8 - 11	81.58 - 112.17	70.81 - 97.36	14 - 18	142.76 - 183.55	123.91 - 159.32
M8	23 - 29	234.53 - 295.71	203.57 - 256.68	28 - 38	285.52 - 387.49	247.83 - 336.34
M10	45 - 57	458.87 - 581.23	398.30 - 504.51	58 - 76	591.43 - 774.97	513.36 - 672.68
M12	67 - 85	683.20 - 866.75	593.02 - 752.34	104 - 134	1,060.49 - 1,366.40	920.50 - 1186.03
M14	106 - 134	1,080.88 - 1,366.40	938.21 - 1,186.03	140 - 188	1,427.58 - 1,917.04	1,239.14 - 1,663.99
M16	152 - 188	1,549.94 - 1,917.04	1,345.35 - 1,663.99	210 - 260	2,141.37 - 2,651.22	1,858.71 - 2,301.26
M18	200 - 240	2,039.40 - 2,447.28	1,770.20 - 2,124.24	280 - 340	2,855.16 - 3,466.98	2,478.28 - 3,009.34
M20	245 - 295	2,498.27 - 3,008.12	2,168.50 - 2,611.05	370 - 450	3,772.89 - 4,588.65	3,274.87 - 3,982.95
M22	-	-	-	530	5,404.41	4,691.03
M24	-	-	-	670	6,831.99	5,930.17
M27	-	-	-	1,000	10,197.00	8,851.00
M30	-	-	-	1,340	13,663.98	11,860.34

Note:
The same values are applied to "fine screw thread."

Appended Table

Hydraulic Hose

The tightening torques for union joints and union adaptors with parallel pipe threads (G, PF) are shown in the table below.

A union joint or adaptor will not become loose or leak as long as it is tightened by the specified torque.

If fluid leaks from the sealed portion, do not attempt to tighten the union joint or adaptor forcibly.

Examine whether any foreign matter or scratches are present on the seat surface.

Tightening a union joint or adaptor forcibly could damage the connection of the joints.

When tightening a union joint or adaptor, use a torque wrench where possible and firmly tighten it by an appropriate torque.

Nominal diameter of the hose size	Nominal diameter of the parallel pipe threads (G, PF)	Tightening torque		
		N-m	kgf-cm	lb-in
6	1/4	25	254.93	221.28
9	3/8	50	509.85	442.55
12	1/2	60	611.82	531.06
15	3/4	120	1,223.64	1,062.12
19	3/4	120	1,223.64	1,062.12
25	1	140	1,427.58	1,239.14
32	1-1/4	170	1,733.49	1,504.67
38	1-1/2	210	2,141.37	1,858.71
50	2	250	2,549.25	2,212.75

Fittings with Parallel Threads (O-Ring Seal Type)

The tightening torques for fittings with parallel threads (O-ring seal method) are shown in the table below.

Tightening the fitting forcibly with a spanner or other such tool to secure it to a set position could damage the fitting, its washers, and other parts.

When tightening an adjustable elbow, use a torque wrench where possible and firmly tighten it by an appropriate torque.

Nominal diameter of thread	Tightening torque		
	N-m	kgf-cm	lb-in.
1/4	34.32 - 49.03	349.96 – 499.96	303.77 – 433.96
3/8	68.65 - 78.45	700.02 – 799.95	607.62 – 694.36
1/2	98.07 - 117.68	1,000.02 – 1,199.98	868.02 – 1,041.59
3/4	147.10 - 176.52	1,499.98 – 1,799.97	1,301.98 – 1,562.38
1	245.17 - 274.59	2,500.00 – 2,799.99	2,170.00 – 2,430.40
1-1/4	294.20	2,999.96	2,603.96
1-1/2	294.20	2,999.96	2,603.96
2	392.27	3,999.98	3,471.98

Principal Tightening Torques

Tightening Torque by Model

LM315GC

Tighten the following bolts and nuts at the torque specified in the table.

For thread locking adhesive, apply a middle strength thread locker (ThreeBond 1322 or equivalent anaerobic sealant).

Location	Code	Part name	Tightening torque			Thread locking adhesive	
			N-m	kgf-cm	lb-in		
Front frame	K0010080202	Bolt, heat-treated M8-20	23 - 38	234.53 - 387.49	203.57 - 336.34	-	
Engine coupling	Joint	K0010080152	Bolt, heat-treated M8-15	23 - 38	234.53 - 387.49	203.57 - 336.34	-
	Belt collar	K0010080302	Bolt, heat-treated M8-30	23 - 38	234.53 - 387.49	203.57 - 336.34	-
Diesel engine	Engine mount	K0017100252	Bolt, heat-treated, small, 10-25 P1.25	45 - 57	458.87 - 581.23	398.30 - 504.51	-
	Wire mounting adjuster	K0011100302	Bolt, heat-treated M10-30P1.25	45 - 57	458.87 - 581.23	398.30 - 504.51	-
	Muffler mounting adjuster	K0011100352	Bolt, heat-treated M10-35P1.25	45 - 57	458.87 - 581.23	398.30 - 504.51	-
	Pulley mounting adjuster	K0010080202	Bolt, heat-treated M8-20	23 - 38	234.53 - 387.49	203.57 - 336.34	-
	Engine pulley D	K0010080202	Bolt, heat-treated M8-20	23 - 38	234.53 - 387.49	203.57 - 336.34	-
	Clamping plates	K0010080252	Bolt, heat-treated M8-25	14 - 19	142.76 - 193.74	123.91 - 168.17	-
Electric components for engine	-	Starter B terminal (M8)	5.9 - 11.7	60.16 - 119.30	52.22 - 103.56	-	
	-	Alternator B terminal (M6)	5.9 - 9.8	60.16 - 99.93	52.22 - 86.74	-	
	-	Glow plug connection terminal nut (M4)	1.0 - 1.8	10.20 - 18.35	8.85 - 15.93	-	
Front wheel	Wheel	K0010100302	Bolt, heat-treated M10-30	58 - 76	591.43 - 774.97	513.36 - 672.68	-
	Wheel mounting base	K0138240002	24 slotted nut high P1.5	180 - 200	1,835.46 - 2,039.40	1,593.18 - 1,770.20	-
3WD rear wheel	Motor	K0000120502	Bolt, M12-50	52 - 67	530.24 - 683.20	460.25 - 593.02	-
	Wheel	K0013101202	Bolt, heat-treated M10-120	58 - 76	591.43 - 774.97	513.36 - 672.68	-
	Wheel mounting base	K0138240002	24 slotted nut high P1.5	180 - 200	1,835.46 - 2,039.40	1,593.18 - 1,770.20	-
	Brake Assy	K0010080252	Bolt, heat-treated M8-25	14 - 19	142.76 - 193.74	123.91 - 168.17	-

Appended Table

Location		Code	Part name	Tightening torque			Thread locking adhesive
				N-m	kgf-cm	lb-in	
2WD rear wheel	Wheel	K0010100302	Bolt, heat-treated M10-30	45 - 57	458.87 - 581.23	398.30 - 504.51	-
	Brake drum	K0010100302	Bolt, heat-treated M10-30	45 - 57	458.87 - 581.23	398.30 - 504.51	-
Mower unit	Reel shaft	LM315GB2102Z0	Reel gear fixing nut	2.5	25.49	22.13	-
	Reel shaft (with Groomer)	LM315GB2101Z0	20-tooth reel gear	2.5	25.49	22.13	-
	Bed knife (Bottom blade)	K0071000222	Screw, heat-treated flathead M6-12	7 - 9	71.38 - 91.77	61.96 - 79.66	-
	Groomer reel	K0160000602	17 special nut P1M4	5 - 10	50.99 - 101.97	44.26 - 88.51	-
	Gearbox	LM315GA1817Z0	Reverse shaft	52 - 67	530.24 - 683.20	460.25 - 593.02	○
		LM315GA1816Z0	Intermediate shaft	52 - 67	530.24 - 683.20	460.25 - 593.02	○
	Front roller	K6083000042	Connected pin, 15-19	29 - 38	295.71 - 387.49	256.68 - 336.34	-
		K0071000152	Bolt, Left-handed Thread	29 - 38	295.71 - 387.49	256.68 - 336.34	-
	Groomer mounting	K6809000270	Screw	18	183.55	159.32	-
		LM315GA1835Z0	Mower mounting bolt, left	20	203.94	177.02	-
LM315GA1836Z0		Mower mounting bolt, right	20	203.94	177.02	-	
Proximity switch NO V-out	K0100050002	NUT, M5	2.5	25.49	22.13	-	
ROPS pillar right/left	K0010120402	Bolt, heat-treated M12-40	104 - 134	1,060.49 - 1,366.40	920.50 - 1,186.03	-	
CR Brush	LM315GC7603Z2	Pulley, reel shaft	14 - 19	142.76 - 193.74	123.91 - 168.17	○	
Steering wheel	K0105160002	NUT, P1.5 M16-3	88	897.34	778.89	-	
Battery terminal	K3612000090	+ Battery terminal 4013-39-1	9	91.77	79.66	-	
	K3612000100	- Battery terminal 4013-39-2	9	91.77	79.66	-	
	K3612000070	+ Battery terminal 4013-D-8-1	9	91.77	79.66	-	
	K3612000080	- Battery terminal 4013-D-8-2	9	91.77	79.66	-	

Daily Check List

LM315GC (Diesel Model)

● . . . Inspect, adjust, supply, clean (first time)

○ . . . Inspect, adjust, supply, clean

▲ . . . Replace (first time)

△ . . . Replace

Maintenance Item		Before Work	After Work	Remarks
Engine	*1	Check engine oil	○	
	*1	Check fuel	○	
		Check fuel filter	○	
	*1	Check coolant	○	
	*1	Check air cleaner	○	
		Check radiator cover	○	
		Check dust-proof mesh	○	
		Check radiator	○	
		Check engine area	○	
		Clean dust-proof mesh		○
	*1	Clean radiator		○
	Clean engine area		○	
Main vehicle		Check hydraulic oil	○	
		Check tire	○	
	*2	Check battery	○	
		Check cover	○	
		Check wire	○	
		Check traveling pedal	○	
		Check brake lever	○	
		Check steering wheel	○	
		Check oil or water leaks	○	
		Check machine exterior	○	
		Check bolts and nuts	○	
		Check hour meter	○	
		Check water temperature gauge	○	
		Check pilot lamp	○	
		Check interlock system	○	
		Check light	○	
		Check grass catcher	○	
	Clean machine exterior		○	
Mower unit		Check reel cutter and bed knife	○	
		Check cover	○	
		Check roller	○	
		Check groomer	○	
		Check CR brush	○	

Appended Table

Maintenance Item		Before Work	After Work	Remarks
Mower unit	Check mower unit appearance	<input type="radio"/>		
	Check bolts and nuts	<input type="radio"/>		
	Clean mower unit		<input type="radio"/>	

- *1: Refer to the Engine's Owner's Manual.
- *2: Refer to the Battery's Owner's Manual.

Appended Table

Maintenance Schedule

LM315GC (Diesel Model)

● . . . Inspect, adjust, supply, clean (first time)

○ . . . Inspect, adjust, supply, clean

▲ . . . Replace (first time)

△ . . . Replace

Maintenance Item		Before Work	After Work	Every Week	Every 8 hrs.	Every 50 hrs.	Every 100 hrs.	Every 200 hrs.	Every 400 hrs.	Every 500 hrs.	Every 800 hrs.	Every 1500 hrs.	Every 3000 hrs.	Every month	Every 6 months	Every year	Every 2 years	Every 4 years	When Required	Remarks		
Engine	*3		○	○																Open valve every week or daily in dusty conditions		
	*2.*3					○																
	*2.*3						○														Air cleaner should be cleaned more often in dusty conditions than in normal conditions	
	*3						○															
	*3						○															
	*2.*3							○														
	*3							○								○						Check every 200 hours or every 6 months whichever comes earlier
	*1.*3									○												
	*1.*3									○												
	*1.*3										○											
*1.*2.*3											○											

Appended Table

Maintenance Item		Before Work	After Work	Every Week	Every 8 hrs.	Every 50 hrs.	Every 100 hrs.	Every 200 hrs.	Every 400 hrs.	Every 500 hrs.	Every 800 hrs.	Every 1500 hrs.	Every 3000 hrs.	Every month	Every 6 months	Every year	Every 2 years	Every 4 years	When Required	Remarks
Engine	*1.*2.*3 Check injection pump												○							
	*3 Replace engine oil					▲	△									△				Initial 50 hours, thereafter every 100 hours or every year whichever comes earlier
	*3 Replace engine oil filter cartridge					▲	△									△				Initial 50 hours, thereafter every 200 hours or every year whichever comes earlier
	*2.*3 Replace fuel filter cartridge							△												
	*3 Replace fan belt									△								△		Replace every 500 hours or 2 years whichever comes earlier
	*2.*3 Replace air cleaner element															△				Replace every 6 cleanings or every year whichever comes earlier
	*3 Replace radiator coolant (L.L.C.)																	△		
	*3 Replace radiator hoses and clamp bands																		△	
	*1.*2.*3 Replace fuel hoses and clamp bands																		△	

Appended Table

Maintenance Item		Before Work	After Work	Every Week	Every 8 hrs.	Every 50 hrs.	Every 100 hrs.	Every 200 hrs.	Every 400 hrs.	Every 500 hrs.	Every 800 hrs.	Every 1500 hrs.	Every 3000 hrs.	Every month	Every 6 months	Every year	Every 2 years	Every 4 years	When Required	Remarks	
Engine	*1.*2.*3	Replace intake air line (air cleaner hose) and clamp bands															△				
Main vehicle		Check hydraulic hose (Moving part)	○																		
		Check belt	○																		
		Check electrical wiring				●	○														
		Check wheel mounting bolts				●	○														
		Check hydraulic hose (Fixed part)					○							○							Check every 100 hours or every month whichever comes earlier
		Check aligning shafts of engine and pump																○			Visual check
		Grease and lubricate					○														
		*6	Grease and Lubricate flexible wires	○		○	○														Maintenance schedules differ according to greasing points
		*1.*6	Adjust air gap of EM clutch														○				Air gap 0.2 - 0.3 mm (0.008 - 0.01 in)
			Replace hydraulic oil					▲			△										
			Replace hydraulic oil suction filter					▲			△										
			Replace hydraulic oil line filter					▲			△										
			Replace transmission grease																△		
		*4	Replace battery																△		
	*1	Replace hydraulic hoses (Moving part)																△			

Appended Table

Maintenance Item		Before Work	After Work	Every Week	Every 8 hrs.	Every 50 hrs.	Every 100 hrs.	Every 200 hrs.	Every 400 hrs.	Every 500 hrs.	Every 800 hrs.	Every 1500 hrs.	Every 3000 hrs.	Every month	Every 6 months	Every year	Every 2 years	Every 4 years	When Required	Remarks	
Main vehicle	*1.*5	Replace hydraulic hoses (Moving part) relating to steering															△				
	*1	Replace hydraulic hoses (Fixed part)																△			
		Replace Belt																		△	
	*1	Replace brake cables																		△	
	*1	Replace traveling cable																		△	
		Replace throttle wire																		△	
	*1	Replace flexible wire																		△	
	*1	Replace brake shoe																		△	
Mower unit		Check blade engagement	○																		
		Check cutting height	○																		
		Check groomer height	○																		
		Check of CR brush belt						○													
		Clean inside of CR brush belt cover						○													
		Grease				○	○														Maintenance schedules differ according to greasing points
		Clean and grease cam bush of the bed knife									○						○				Every 500 hours or every year whichever comes earlier, and when replacing a bedknife additionally
		Backlap																		○	
		Engage blades																		○	
		Adjust mowing height																		○	

Appended Table

Maintenance Item		Before Work	After Work	Every Week	Every 8 hrs.	Every 50 hrs.	Every 100 hrs.	Every 200 hrs.	Every 400 hrs.	Every 500 hrs.	Every 800 hrs.	Every 1500 hrs.	Every 3000 hrs.	Every month	Every 6 months	Every year	Every 2 years	Every 4 years	When Required	Remarks	
Mower unit		Adjust cutter adjustment spring																			O
		Adjust cam																			O
		Regrind reel cutter																			O
		Adjust groomer																			O
		Adjust CR brush																			O
		Adjust drive belt tension of CR brush																			O
	*1	Replace bearing in the gear case															△				
	*1	Replace bearing of the front and rear rollers															△				
	*1	Replace oil seal in the gear case															△				
	*1	Replace oil seal of the front and rear rollers															△				
*1	Replace grease in the gear case															△					
*1.*6	Add grease to reel cutter shaft bearing															O					
*1	Replace CR brush bearing															△					

- *1: Consult your local Baroness Dealer or local KUBOTA Dealer for this service.
- The items above (*2 marked) are registered as emission related critical parts by KUBOTA in the U.S. EPA nonroad emission regulation.
As the engine owner, you are responsible for the performance of the required maintenance on the engine according to the above instruction. Please see the Engine's Warranty Statement in detail.
- *3: Refer to the Engine's Owner's Manual.
- *4: Refer to the Battery's Owner's Manual.
- *5: Be sure to replace hydraulic hoses for steering cylinder and hydraulic hoses for hydraulic motor of wheel relating to steering every two years.
- *6: Failed maintenance may largely cause damage to the flexible wires.
- The values for consumables are not guaranteed.

Appended Table

List of Adjusted Values

Cutter adjustment spring	30 mm (1.18 in)	Total length of spring
Fan belt	7 - 9 mm (0.28 - 0.35 in)	Belt slack
	Adjustment: 200 - 300 N (20.39 - 30.59 kgf)	Measurement of belt tension by using a sonic type tension meter
	Replacement: 344 - 441 N (35.08 - 44.97 kgf)	
Reel Cutter Drive Belt	13 ± 2 mm (0.51 ± 0.08 in)	Belt slack under load of 55 N (5.5 kgf)
Transmission input belt	50 mm (1.97 in)	Total length of spring

Daily Check Records Page 9-2

Maintenance RecordsPage 9-5

Records

Records

Daily Check Records

LM315GC (Diesel Model)

Use this table freely for your records of the daily check.

Model		Serial Number	
-------	--	---------------	--

Items										
Engine	Check engine oil									
	Check fuel									
	Check fuel filter									
	Check coolant									
	Check air cleaner									
	Check radiator cover									
	Check dust-proof mesh									
	Check radiator									
	Check engine area									
	Clean dust-proof mesh									
	Clean radiator									
	Clean engine area									

Items										
Main vehicle	Check hydraulic oil									
	Check tire									
	Check battery									
	Check cover									
	Check wire									
	Check traveling pedal									
	Check brake lever									
	Check steering wheel									
	Check oil or water leaks									
	Check machine exterior									
	Check bolts and nuts									
	Check hour meter									
	Check water temperature gauge									
	Check pilot lamp									

Records

Records

Items											
Main vehicle	Check interlock system										
	Check light										
	Check grass catcher										
	Clean machine exterior										
Mower unit	Check reel cutter and bed knife										
	Check cover										
	Check roller										
	Check groomer										
	Check CR brush										
	Check mower unit appearance										
	Check bolts and nuts										
	Clean mower unit										

Maintenance Records

LM315GC (Diesel Model)

Use this table freely for your records of the maintenance.

Model		Serial Number	
-------	--	---------------	--

	Items									
Engine	Open air cleaner evacuator valve to remove dust									
	Check fuel hoses and clamp bands									
	Clean air cleaner element									
	Clean fuel filter									
	Check fan belt tightness									
	Check intake air line (air cleaner hose)									
	Check radiator hoses and clamp bands									
	Clean fuel tank interior									
	Clean water jacket (radiator interior)									
	Check valve clearance									
	Check fuel injection nozzle injection pressure									
	Check injection pump									

Records

Records

Items											
Engine	Replace engine oil										
	Replace engine oil filter cartridge										
	Replace fuel filter cartridge										
	Replace fan belt										
	Replace air cleaner element										
	Replace radiator coolant (L.L.C.)										
	Replace radiator hoses and clamp bands										
	Replace fuel hoses and clamp bands										
	Replace intake air line (air cleaner hose) and clamp bands										
Main vehicle	Check hydraulic hose (Moving part)										
	Check belt										
	Check electrical wiring										
	Check wheel mounting bolts										
	Check hydraulic hose (Fixed part)										

Items											
Main vehicle	Check aligning shafts of engine and pump										
	Grease and lubricate										
	Grease and Lubricate flexible wires										
	Adjust air gap of EM clutch										
	Replace hydraulic oil										
	Replace hydraulic oil suction filter										
	Replace hydraulic oil line filter										
	Replace transmission grease										
	Replace battery										
	Replace hydraulic hoses (Moving part)										
	Replace hydraulic hoses (Moving part) relating to steering										
	Replace hydraulic hoses (Fixed part)										
	Replace Belt										
Replace brake cables											

Records

Records

Items											
Main vehicle	Replace traveling cable										
	Replace throttle wire										
	Replace flexible wire										
	Replace brake shoe										
Mower unit	Check blade engagement										
	Check cutting height										
	Check groomer height										
	Check of CR brush belt										
	Clean inside of CR brush belt cover										
	Grease										
	Clean and grease cam bush of the bed knife										
	Backlap										
	Engage blades										
	Adjust mowing height										

Items											
Mower unit	Adjust cutter adjustment spring										
	Adjust cam										
	Regrind reel cutter										
	Adjust groomer										
	Adjust CR brush										
	Adjust drive belt tension of CR brush										
	Replace bearing in the gear case										
	Replace bearing of the front and rear rollers										
	Replace oil seal in the gear case										
	Replace oil seal of the front and rear rollers										
	Replace grease in the gear case										
	Add grease to reel cutter shaft bearing										
	Replace CR brush bearing										

Records

Records

BARONESS[®]
Quality on Demand

 **KYOEISHA CO., LTD.**
Head Office 1-26, Miyuki-cho, Toyokawa-city, Tel :+81-533-84-1390
Aichi-pref, 442-8530 JAPAN Fax:+81-533-84-1220