

SP05A

Bunker Rake

Owner's Operating Manual

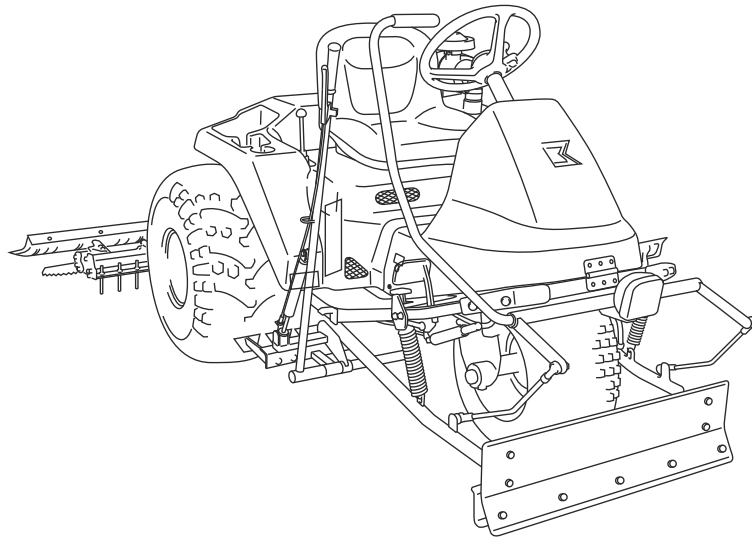

Serial No. SP05A : 21506-

"Required reading"
Read this manual before using the machine.

BARONESS[®]
Quality on Demand

Original Instructions Ver.2.9

SP05A

Regulations

EU Regulations

(For EU)

This product complies with all relevant EU Regulations.

For more information, please refer to the Declaration of Conformity attached.

Thank you for purchasing the Baroness product. This manual describes the proper handling, adjustment, and inspection of your product. We hope you will use the product safely, and take advantage of its best performance.

Keeping The Owner's Operating Manual

Keep this Owner's Operating Manual in the box on the right side of the seat.

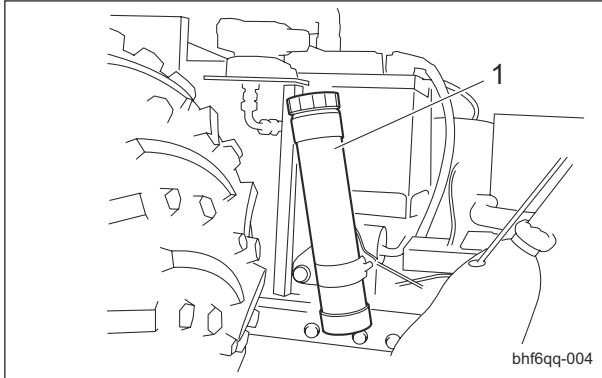

Keeping The Owner's Operating Manual_001

1	Box
---	-----

QR Code

(*QR Code is a registered trademark of DENSO WAVE INCORPORATED.)

A QR code label is affixed on the machine.

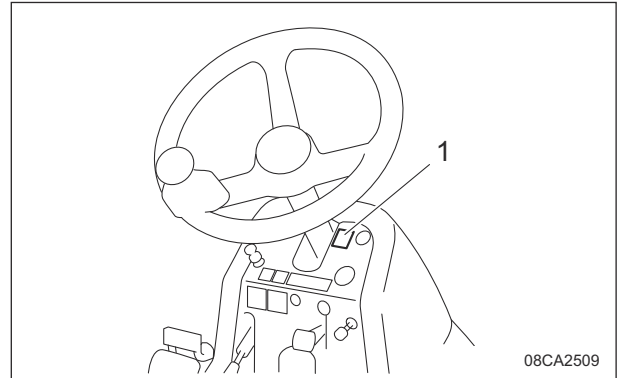

QR Code_001

1	QR code label
---	---------------

Scan the QR code with your smartphone for easy access to Baroness Manual Reference Service where you can browse Owner's Operating Manual and Parts Catalog.
<https://doc.baroness-international.com/manuals/SP05A>



QR Code_002

Introduction

Read this manual carefully to ensure that you thoroughly understand how to properly operate and maintain the product, and to avoid causing injury to yourself or others.

The operator is responsible for operating the product properly and safely.

Maintenance service for this machine should be performed by a mechanic with expertise.

If you have any questions concerning maintenance or genuine parts, please contact a Baroness dealer or Kyoisha.

When making inquiries about your product, please specify the model and serial number.

When loaning or transferring the product, please also provide this manual together with the product.

Kyoeisha Co., Ltd.

Warning Symbols

This manual uses the following warning symbols for handling precautions that are important for your safety.



696cq5-001

Warning symbol

This symbol indicates the articles regarding "Danger," "Warning," or "Caution."

Those articles describe important safety precautions and so read them carefully to understand completely before operating the machine.

Failure to adequately follow these safety precautions may cause an accident.

Danger

This symbol indicates that serious injury or death will occur if the warning is ignored.

Warning

This symbol indicates that serious injury or death may occur if the warning is ignored.

Caution

This symbol indicates that injury or damage to property may occur if the warning is ignored.

Important

This symbol indicates precautions on the mechanism of the machine.

Precautionary Statement

 Caution

The information described in this manual is subject to change for improvement without prior notice.

When replacing parts, be sure to use genuine Baroness parts or parts designated by Kyoeshia.

Note that the Baroness product warranty may not apply to defects caused by the use of parts from other companies.

Prior to use, carefully read the following manuals to thoroughly understand the contents for safe and correct operation.

- Baroness Owner's Operating Manual
- The Engine's Owner's Manual
- The Battery's Owner's Manual

Purpose

This product is intended for leveling bunkers at golf courses.

Do not use this product in any other way than its intended purpose, and do not modify the product.

Operating this product for other purposes and modifying it may be very dangerous and may cause damage to the machine.

In addition, this product is not authorized for operation as a special motor vehicle. Do not operate it on public roads.

SP05A

Introduction

Contents

Safety	Page 1-1	Inspection and Cleaning	Page 6-3
Safe Operating Practices	Page 1-2	Supplying Fluids	Page 6-6
Disposal	Page 2-1	Greasing	Page 6-8
Recycle and Waste Disposal	Page 2-2	Lubrication	Page 6-11
Product Overview	Page 3-1	Adjustment	Page 6-12
Specifications	Page 3-2	Replacement	Page 6-15
Names of Each Section	Page 3-4	Storage	Page 6-24
Regulation Decals	Page 3-6	Repair	Page 7-1
Safety Signs and Instruction Signs	Page 3-9	Precautions for Repair	Page 7-2
Operation Decals	Page 3-13	Adjustment	Page 7-2
Description of Functions	Page 4-1	Replacement	Page 7-5
Key Switch	Page 4-2	Towing	Page 7-6
Throttle Lever	Page 4-2	Appended Table	Page 8-1
Choke Lever	Page 4-2	Tightening Torques	Page 8-2
Up/Down Switch Lever	Page 4-3	Daily Check List	Page 8-6
2WD/3WD Selector Lever	Page 4-3	Maintenance Schedule	Page 8-7
2WD/3WD Selector Switch	Page 4-4	List of Adjusted Values	Page 8-8
Light Switch	Page 4-4	Records	Page 9-1
Traveling Pedal	Page 4-4	Daily Check Records	Page 9-2
Brake Pedal	Page 4-5	Maintenance Records	Page 9-5
Broom Holder	Page 4-5		
Cargo Box	Page 4-5		
Instruments on The Operation Panel	Page 4-6		
Safety Device	Page 4-6		
Warning Mechanisms	Page 4-6		
Handling Instructions	Page 5-1		
Operations before Service	Page 5-2		
Inspection before Use	Page 5-3		
Adjustment before Work	Page 5-10		
Mounting and Dismounting	Page 5-10		
Start/Stop of Engine	Page 5-11		
Parking and Stopping	Page 5-12		
Move	Page 5-12		
Operations	Page 5-12		
Transporting	Page 5-16		
Cleaning after Use	Page 5-16		
Storage	Page 5-16		
Maintenance	Page 6-1		
Precautions for Maintenance	Page 6-2		
Jacking Up The Machine	Page 6-2		

SP05A

Contents

Safe Operating Practices Page 1-2

Training Page 1-2

Preparation Page 1-2

Operation Page 1-3

Maintenance Page 1-4

Storage Page 1-4



Safety

Failure to adequately follow these safety precautions may cause an accident resulting in injury or death.

Danger

This product is designed to ensure safe operation and has been tested and inspected thoroughly before shipment from the factory. The product is equipped with safety devices to prevent accidents.

However, whether the product demonstrates its original performance level depends on the manner in which it is operated and handled, as well as the manner in which it is managed on a daily basis.

Inappropriate use or management of the product may result in injury or death.

Observe the following safety instructions to ensure safe operation.

Safe Operating Practices

Training

1. Read this manual and other training material carefully.

Be familiar with the controls, safety signs, and the proper use of the equipment.

2. If the operator or mechanic can not read the language used in this manual, it is the owner's responsibility to explain this material to them.

3. All operators and mechanics should seek and obtain professional and practical instruction.

The owner is responsible for training the users.

Such instruction should emphasize:

- [1] The need for care and concentration when working with ride-on machines.

- [2] Control of a ride-on machine sliding on a slope will not be regained by the application of the brake.

The main reasons for loss of control are

- Insufficient wheel grip
- Being driven too fast
- Inadequate braking
- The type of machine is unsuitable for its task
- Lack of awareness of the effect of ground conditions, especially slopes
- Incorrect hitching and load distribution

4. Never allow children or people unfamiliar with these instructions to use or service the machine.

Local regulations may restrict the age of the operator.

5. The owner/user can prevent and is responsible for accidents or injuries occurring to themselves, other people, or property.
6. Keep in mind that the owner, operator, and mechanic are responsible for accidents or hazards occurring to other people or their property.
7. You can find additional safety information where needed throughout this manual.
8. Determine the left and right sides of the machine from the normal operating position.

Preparation

1. Evaluate the terrain to determine what accessories and attachments are needed to properly and safely perform the job. Only use accessories and attachments approved by the manufacturer.
2. While operating, always wear substantial footwear, long trousers, hard hat, safety glasses, mask, and ear protection. Long hair, loose clothing, or jewelry may get tangled in moving parts. Do not operate the equipment when barefoot or wearing open sandals.
3. Inspect the area where the equipment is to be used and remove all objects such as rocks, toys and wire which can be thrown by the machine.
4. Keep children out of the operating area and under the watchful care of a responsible adult other than the operator.
5. Exercise care in the handling of fuel.

Warning

Fuel is highly flammable.

Take the following precautions:

- [1] Store fuel in containers specifically designed for this purpose.
- [2] Add fuel before starting the engine. Never remove the cap of the fuel tank or add fuel while the engine is running or when the engine is hot.
- [3] Refuel outdoors only and do not smoke while refueling.

- [4] If fuel is spilled, do not attempt to start the engine but move the machine away from the area of spillage and avoid creating any source of ignition until petrol vapours have dissipated;
- [5] Replace all fuel tanks and container caps securely.
- 6. Check that operator's presence controls, safety switches and shields are attached and functioning properly.
Do not operate unless they are functioning properly.
- 7. If the brake operation is faulty, be sure to adjust or repair them before operating the machine.
- 8. Replace faulty mufflers.

Operation

- 1. Do not operate the machine under the influence of alcohol or drugs.
- 2. Do not operate the engine in a confined space where dangerous carbon monoxide fumes can collect.
- 3. Be sure all drives and shift are in neutral and parking brake is engaged before starting engine.
Only start engine from the operator's position.
Use seat belts if provided.
- 4. Do not change the engine governor settings or overspeed the engine.
Operating the engine at excessive speed may increase the hazard of personal injury.
- 5. Never operate the machine with damaged guards, shields, or without safety protective devices in place.
Be sure all interlocks are attached, adjusted properly, and functioning properly.
- 6. Keep hands and feet away from the rotating parts.
- 7. Do not carry passengers.
- 8. Never operate while people, especially children, or pets are nearby.
- 9. Only operate in good light, keeping away from holes and hidden hazards.
- 10. Do not operate the machine when there is the risk of lightning.
- 11. Do not stop or start suddenly.
- 12. Look behind and down before backing up to be sure of a clear path.

- 13. Slow down and use caution when making turns and crossing roads and sidewalks.
- 14. Use care when approaching blind corners, shrubs, trees, or other objects that may obscure vision.
- 15. Do not take your eyes off the road ahead.
Do not operate the machine with no hands.
- 16. Remember there is no such thing as a safe slope.
Travel on grass slopes requires particular care.
To guard against overturning, follow these instructions.
 - [1] Do not stop or start suddenly when going up or downhill.
 - [2] Engage clutch slowly, always keep machine in gear, especially when traveling downhill.
 - [3] Machine speeds should be kept low on slopes and during turns.
 - [4] Stay alert for humps and hollows and other hidden hazards.
- 17. Never use the machine on a slope with an angle of gradient that is greater than that specified or in a place where there is a danger of the machine slipping.
- 18. Use extra care while operating machine with a grass catcher or other attachments.
They can affect the stability of the machine.
- 19. Do the following before leaving the operator's position.
 - [1] Stop on level ground.
 - [2] Set the parking brake.
 - [3] Stop the engine.
 - [4] Remove the ignition key.
- 20. Stop the engine in the following conditions.
 - [1] Before refuelling.
 - [2] Before making height or depth adjustment unless adjustment can be made from the operator's position.
 - [3] Before checking, cleaning or working on the machine.
 - [4] After striking a foreign object or if an abnormal vibration occurs.
Inspect the machine for damage and make repairs before restarting and operating the equipment.
- 21. Reduce the throttle setting during engine run-out.

Safety

22. Take care when loading or unloading the machine into a trailer or a truck.
Load or unload the machine in a flat and safe place.
Before loading or unloading, set the parking brake on the truck or trailer, stop the engine, and chock the wheels.
When transporting the machine on a truck or a trailer, set the parking brake, stop the engine, and fasten the machine to the truck with a rope or other suitable restraining device that has sufficient strength.
When using a running board, select one with sufficient strength, length, and width and that will not cause the machine to slip.
23. Close the fuel valve before transporting the machine.

Maintenance

1. Never allow untrained personnel to service machine.
2. Implement the following work before adjusting, cleaning or repairing.
 - [1] Stop the machine on level ground.
 - [2] Set the parking brake.
 - [3] Stop the engine.
 - [4] Remove the ignition key.
 - [5] Wait for all movement to stop.
3. Allow the engine/muffler to cool before checking/maintenance.
4. To reduce the fire hazard, keep hot parts such as the engine and silencer/muffler, battery compartment and fuel storage area free of grass, leaves, or excessive grease. Clean up oil or fuel spillage.
5. Appropriately manage and correctly use the tools necessary for servicing or adjusting the machine.
6. Disconnect battery before making any repairs.
Disconnect the negative terminal first and the positive last.
Reconnect positive first and negative last.
7. Use jack stands to support components when required.
8. Keep hands and feet away from moving parts.
If possible, do not make adjustments with the engine running.
9. Make sure that parts such as wires are not touching each other and that their covers have not come off.
10. Keep all parts in good working condition and all hardware tightened.
Replace all worn or damaged decals.
11. Keep all nuts, bolts and screws tight to be sure the equipment is in safe working condition.
12. Carefully release pressure from components with stored energy.
13. Be sure to depressurize the hydraulic system before performing maintenance operations on it such as removing hydraulic equipment.
14. Check whether line connectors in the hydraulic system are properly tightened.
Before applying hydraulic pressure, check the connections of the hydraulic pressure lines and the condition of the hoses.
15. When checking the hydraulic circuit for pinhole leaks or oil leakage from nozzles, do not use your hands.
Use items such as paper or corrugated cardboard to find leakage points.
Be extremely careful with high-pressure oil as it may pierce your skin, resulting in an injury.
If fluid is injected into the skin it must be surgically removed within a few hours by a doctor familiar with this form of injury or gangrene may result.
16. Charge batteries in an open well ventilated area, away from spark and flames.
Unplug charger before connecting or disconnecting from battery.
Wear protective clothing and use insulated tools.
17. If the fuel tank has to be drained, do this outdoors.

Storage

1. Allow the engine to cool before storing in any enclosure.
2. Only cover the machine with a sheet after hot parts have sufficiently cooled down.
3. Never store the equipment with fuel in the tank inside a building where fumes may reach an open flame or spark.
4. If the engine is provided with a shut-off valve, shut off valve while storing or transporting.

5. Do not store fuel near flames.

Recycle and Waste Disposal Page 2-2

About RecyclePage 2-2

About Waste Disposal Page 2-2

Disposal

Disposal

Recycle and Waste Disposal

About Recycle

Recycling battery etc. is recommended for environmental conservation and economical use of resources.

It may be required by local laws.

About Waste Disposal

Make sure that waste generated when servicing or repairing the machine is disposed of in accordance with local regulations. (e.g. waste oil, antifreeze, rubber products, and wires etc.)

Specifications Page 3-2

SpecificationsPage 3-2

Sound Pressure Level Page 3-3

Sound Power Level Page 3-3

Vibration Level Page 3-3

Carbon Dioxide (CO₂) EmissionsPage 3-3

Names of Each Section Page 3-4

Regulation DecalsPage 3-6

Positions of Regulation Decals Page 3-6

Description of Regulation Decals Page 3-6

Safety Signs and Instruction Signs Page 3-9

About Safety Signs and Instruction
SignsPage 3-9

Positions of Safety Decals and
Instruction Decals Page 3-9

Description of Safety Decals and
Instruction Decals Page 3-10

Operation Decals Page 3-13

Positions of Operation Decals Page 3-13

Description of Operation Decals Page 3-14

Product Overview

Specifications

Specifications

Model		SP05A				
Name		Bunker Rake				
Type		2WD			3WD	
Dimensions	Total length	with Rake	215 cm	84.65 in	←	←
		with Rake and Blade	230 cm	90.55 in	←	←
	Total width		190 cm	74.80 in	←	←
	Total height	Steering wheel	120 cm	47.24 in	←	←
Weight	Machine (empty fuel tank)	with Rake	448 kg	987.65 lb	475 kg	1047.18 lb
	Blade		25 kg	55.11 lb	←	←
	Cultivator		19 kg	41.89 lb	←	←
	Finishing brush		10.6 kg	23.37 lb	←	←
Minimum turning radius		339 cm	133.46 in	←	←	
Engine	Model		Vanguard 356447		←	
	Type		Air-cooled 4-cycle gasoline engine		←	
	Total displacement		570 cm ³ (0.57 L)	34.78 cu.in.	←	←
	Maximum output		13.4 kW (18.2 PS)/3,600 rpm		←	
	Rated output		-		-	
Fuel tank capacity		Gasoline 15.0 dm ³ (15.0 L)	Gasoline 3.96 U.S.gal.	←	←	
Fuel consumption		310 g/kW · h (rated output)	228 g/PS · h (rated output)	←	←	
Engine oil capacity		1.6 dm ³ (1.6 L)	0.42 U.S.gal.	←	←	
Coolant volume		-		-		
Hydraulic tank capacity		15.0 dm ³ (15.0 L)	3.96 U.S.gal.	←	←	
Transmission oil capacity		-		-		
Operating width	Rake		190 cm	74.80 in	←	←
	Blade		80 cm	31.50 in	←	←
	Cultivator		116 cm	45.67 in	←	←
	Finishing brush		195 cm	76.77 in	←	←
Operating height		-		-		
Drive	Traveling		HST		HST (2WD/3WD selectable)	
	Mowing		-		-	
Speed (HST)	Forward	0 - 16.0 km/h	0 - 9.94 mph	0 - 12.8 km/h	0 - 7.96 mph	
	Reverse	0 - 6.0 km/h	0 - 3.73 mph	0 - 4.8 km/h	0 - 2.98 mph	
Speed (Mechanical)		-		-		
Efficiency		-		-		
Maximum inclination for operation		15 degrees		←		
Tire size	Front wheel	PD21 x 11.00 - 10		←		

Product Overview

Tire size	Rear wheel	25 x 13.00 - 9		←	
Tire pneumatic pressure	Front wheel	70 kPa (0.7 kgf/cm ²)	10 psi	←	←
	Rear wheel	40 kPa (0.4 kgf/cm ²)	6 psi	←	←
Battery		46B19R		←	
Engine plug		PLUG, CHAMPION XC92YC		←	

The factory default maximum engine rpm is 3,000 rpm.

Sound Pressure Level

Sound Pressure Level

This machine was confirmed to have a continuous A-weighted sound pressure level of 84 dB by measuring identical machines in accordance with the procedure specified in ISO5395-1:2013.

Sound Power Level

Sound Power Level

This machine was confirmed to have a sound power level of 98 dB by measuring identical machines in accordance with the procedure specified in ISO5395-1:2013.

Vibration Level

Hand-Arm Vibration

This machine was confirmed not to exceed a vibration level of 2.5 m/s² to hands and arms by measuring identical machines in accordance with the procedure specified in ISO 5395-1:2013.

Whole Body Vibration

This machine was confirmed not to exceed a vibration level of 0.5 m/s² to the whole body by measuring identical machines in accordance with the procedure specified in ISO 5395-1:2013.

Carbon Dioxide (CO₂) Emissions

For the CO₂ value on the engine of this machine, refer to the engine's owner's manual.

Product Overview

Names of Each Section

Overall view A

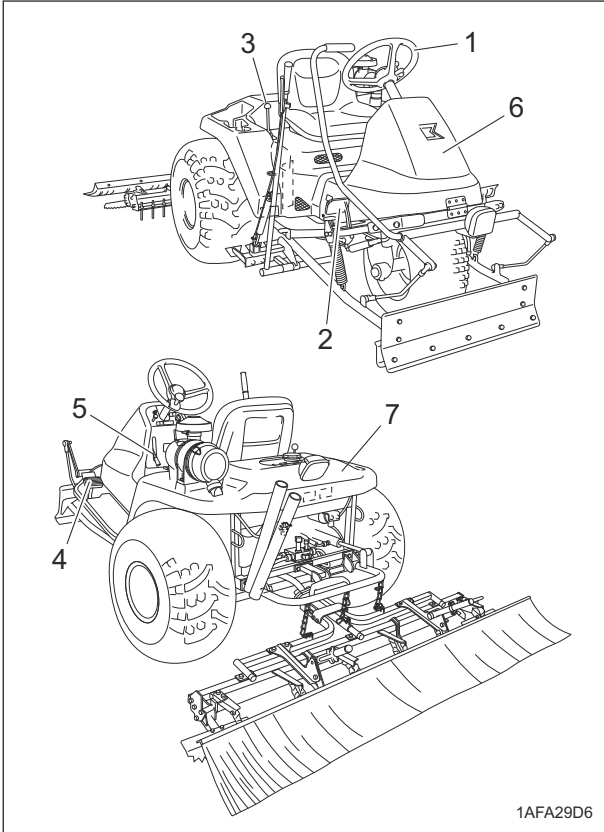

1AFA29D6

Names of Each Section_001

1	Steering wheel
2	Traveling pedal
3	2WD/3WD selector lever (3WD: #21931)
4	Brake pedal
5	Tilt lever
6	Front cover
7	Rear cover

Overall view B

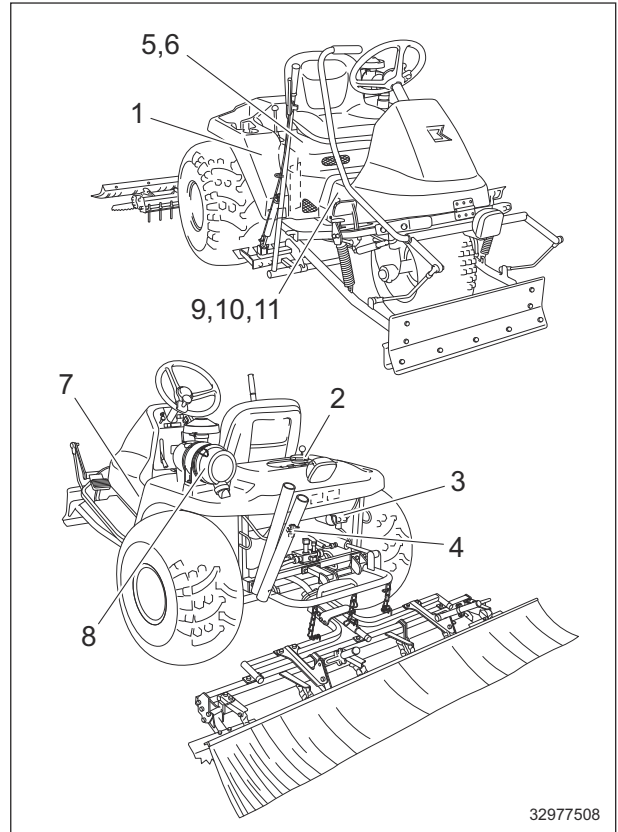

32977508

Names of Each Section_002

1	Battery
2	Fuel tank
3	Fuel filter
4	Fuel strainer
5	Engine
6	Engine oil filter
7	Oil cooler
8	Air cleaner
9	Hydraulic tank
10	Air breather
11	Hydraulic oil line filter

Product Overview

Overall view C

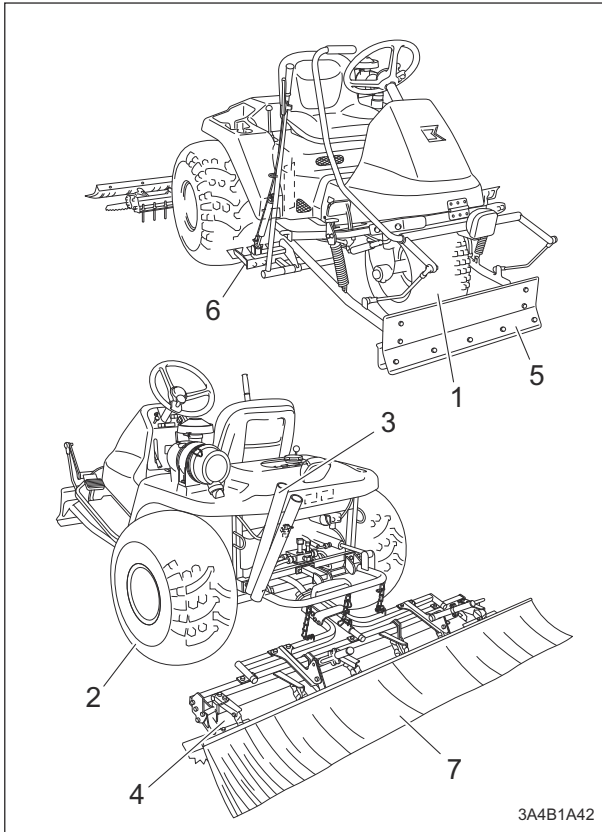

1	Key switch
2	Throttle lever
3	Choke lever
4	Up/Down switch lever
5	Light switch
6	2WD/3WD selector switch (3WD: #21932-)
7	LED (3WD: #21932-)

Names of Each Section_003

1	Front tire
2	Rear tire
3	Broom holder
4	Rake
5	Blade (option)
6	Cultivator (option)
7	Finishing brush (option)

Operation panel

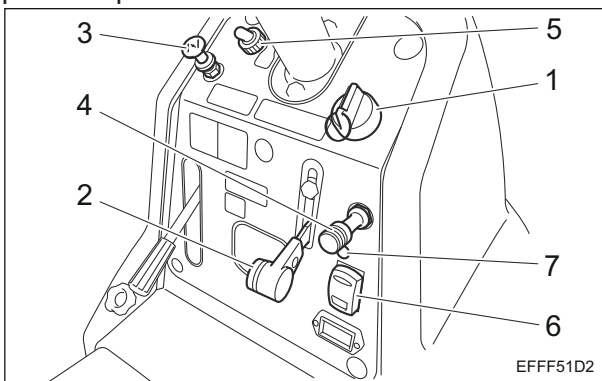

Names of Each Section_004

Product Overview

Regulation Decals

Positions of Regulation Decals

Main vehicle

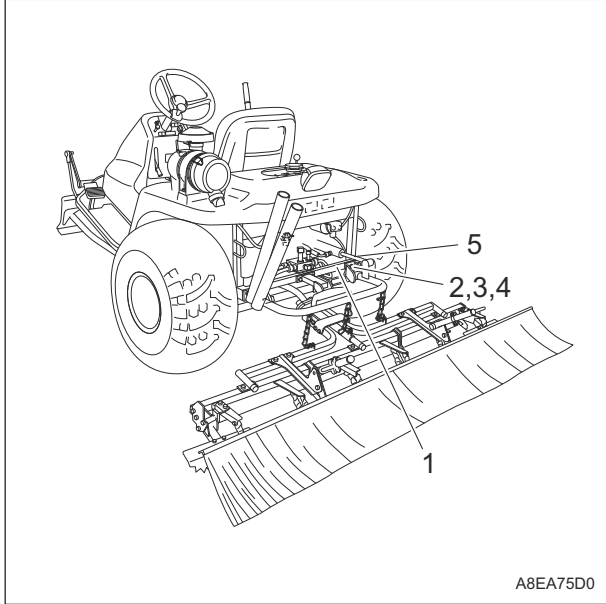

Positions of Regulation Decals_001

1	Serial number plate
2	Specification decal
3	CE mark
4	UKCA mark (#21039 - 21449)
5	Year of manufacture decal

Battery

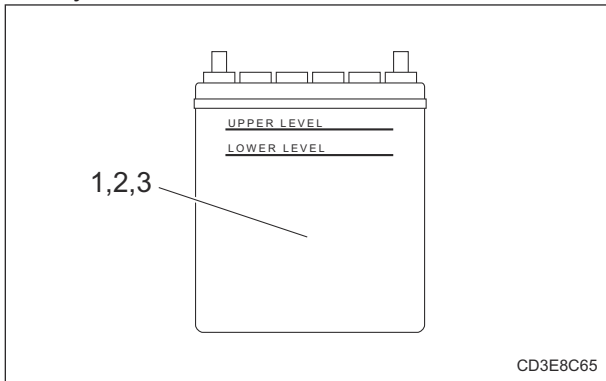

Positions of Regulation Decals_002

1	Battery capacity decal
2	EU battery regulation decal
3	Recycle decal

Description of Regulation Decals

Serial Number Plate

The serial number plate indicates the model and serial number of the machine.

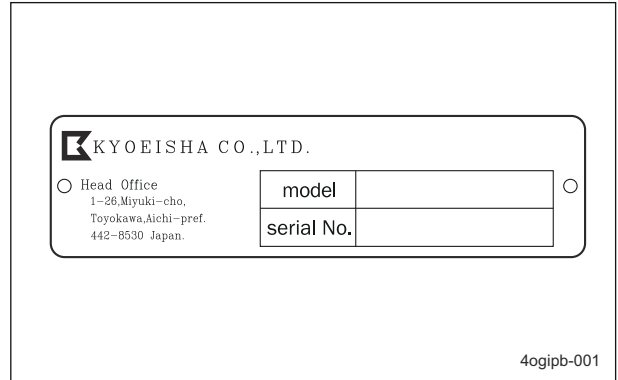

Serial Number Plate_001

Specification Decal

(For EU)

The Specification decal indicates the model and weight, etc.

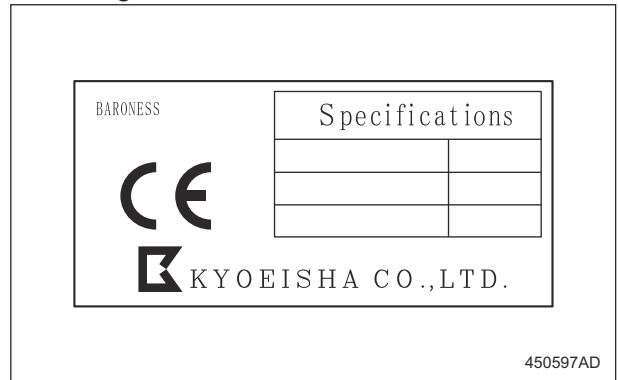

Specification Decal_001

CE Mark

(For EU)

CE mark indicates that the machine sold in the EU nations complies with the EU requirements.

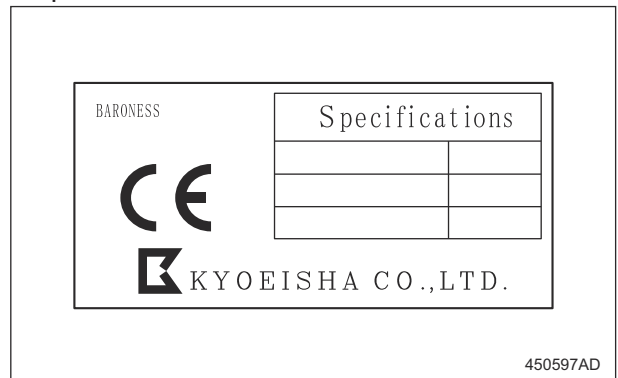

CE Mark_001

UKCA Mark

(For UK)
UKCA mark indicates that the machine sold in the UK complies with the UK requirements.



UKCA Mark_001

Battery Capacity Decal

(For EU)
The battery capacity decal indicates the capacity by 20HR and CCA.

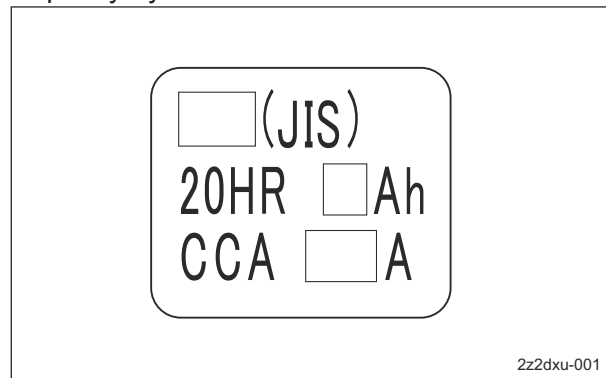

Battery Capacity Decal_001

Year of Manufacture Decal

(For EU)
The year of manufacture decal indicates the year when this machine was manufactured.

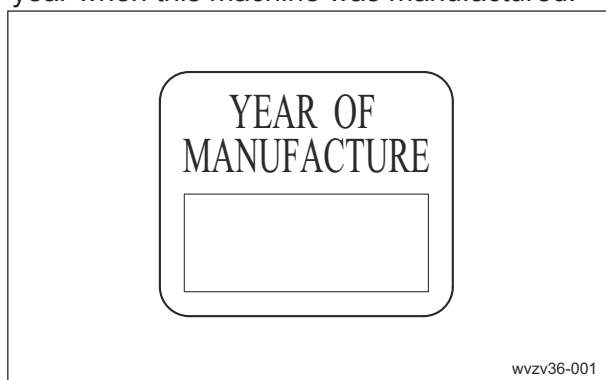

Year of Manufacture Decal_001

EU Battery Regulation Decal

(For EU)
The EU battery regulation decal indicates compliance with the EU battery regulation.

- The following information about the battery manufacturing company is written in the decal.
 - Company name
 - Address
 - Website URL
- You can scan the QR code with your smartphone to access the corresponding battery information.
(*QR Code is a registered trademark of DENSO WAVE INCORPORATED.)
- CE mark indicates that the battery installed in a machine sold in the EU nations complies with the EU requirements.

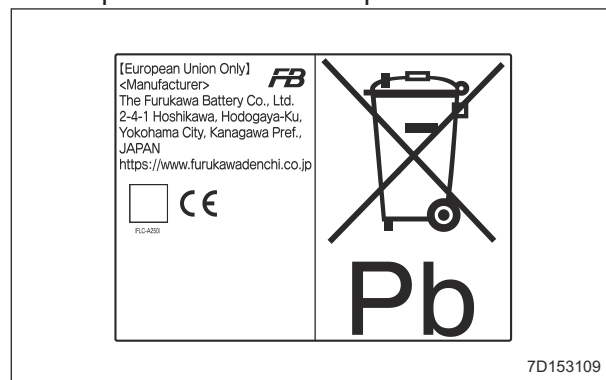

EU Battery Regulation Decal_001

Product Overview

Recycle Decal

Recycle Decal illustrates Recycle Mark in accordance with local regulation.

(For EU)

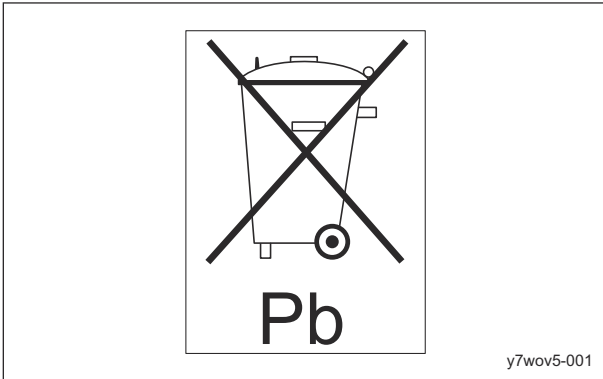

Recycle Decal_001

(For USA)



Recycle Decal_002

Safety Signs and Instruction Signs

About Safety Signs and Instruction Signs

Important

Safety decals and instruction decals are attached to this product. Make sure that they are preserved in their entirety. If they are damaged, become dirty, or peel off, replace them with new ones.

Part numbers for decals that need to be replaced are listed in the parts catalog. Order them from a Baroness dealer or Kyo-eisha.

Positions of Safety Decals and Instruction Decals

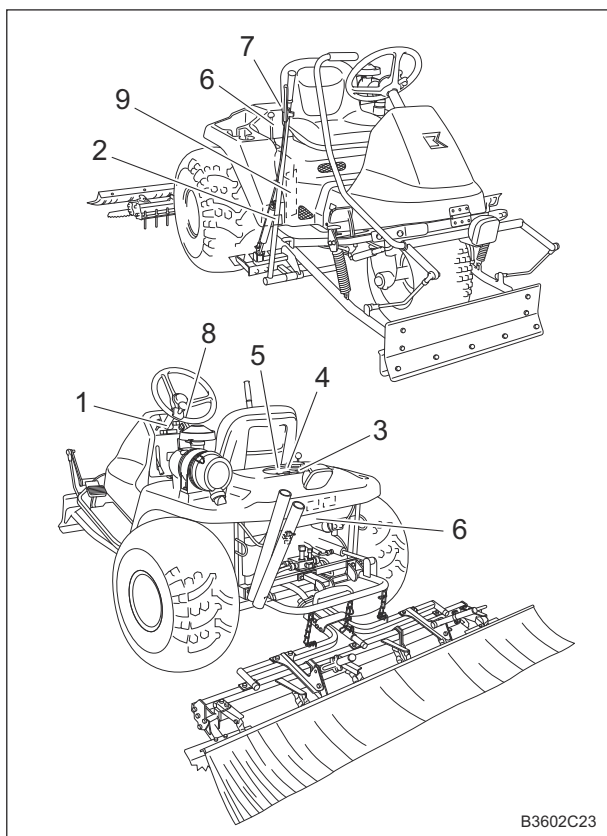

B3602C23

Positions of Safety Decals and Instruction Decals_001

1	Operation decal
2	Caution for getting pinched decal
3	Caution exhaust gas decal
4	Lead-free gasoline decal
5	Fire prohibited decal
6	Caution for getting entangled decal
7	Caution for high temperatures decal
8	Caution to noise decal
9	Read owner's manual decal (#21001 – 21372)

Product Overview

Description of Safety Decals and Instruction Decals

Operation Decal

- #21931
SP05---0560C0
- #21932-
SP05---0560D0
Sticker, operation

1.



Read the Owner's Operating Manual.

2.

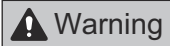

Apply the parking brake, stop the engine, remove the ignition key, and then leave the machine.

3.

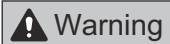

Rollover - Do not work on slopes of 15 degrees or more. When you descend a slope, drive at low speed.

4.

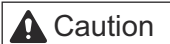

Thrown objects - Be sure that people around the machine keep a safe distance away.

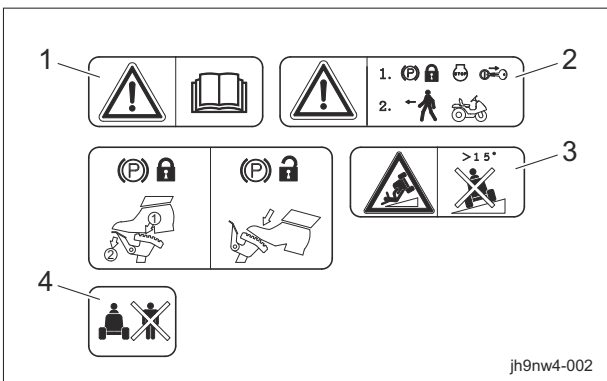

Operation Decal_001

Caution for Getting Pinched Decal

K4205001930
DECAL, CAUTION GETTING CAUGHT
HANDS/FEET



May get pinched - There is a risk of being pinched.

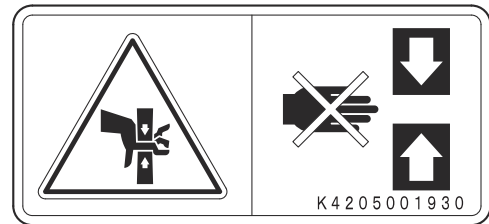

tgp289-002

Caution for Getting Pinched Decal_001

Caution Exhaust Gas Decal

K4205001950
Decal, caution exhaust gas

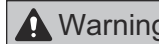

Caution for exhaust gas

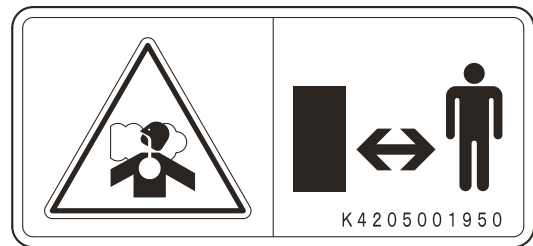

kwx52-001

Caution Exhaust Gas Decal_001

Product Overview

Lead-Free Gasoline Decal

K4209001310
Decal, lead-free gasoline
Use lead-free gasoline.



Lead-Free Gasoline Decal_001

Fire Prohibited Decal

K4205001940
Decal, fire prohibited

Warning

Keep away from fire.



Fire Prohibited Decal_001

Caution for Getting Entangled Decal

K4205001910
DECAL, CAUTION NOT TO GET CAUGHT
IN

Warning

Watch for rotating parts - Keep your hands away from the belts while the engine is running.

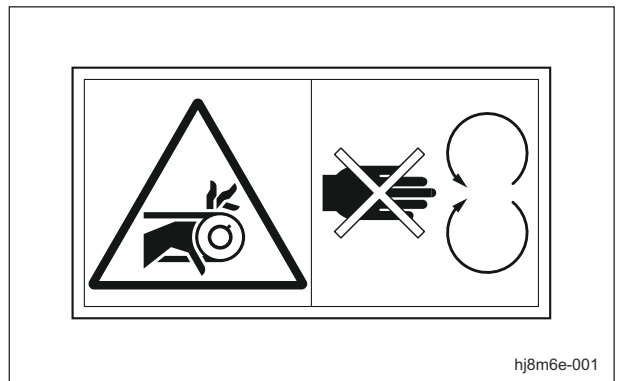

Caution for Getting Entangled Decal_001

Caution for High Temperatures Decal

K4205001920
Decal, caution for high temperatures

Caution

High temperature - Do not touch. Otherwise, you will get burned.



Caution for High Temperatures Decal_001

Product Overview

Caution to Noise Decal

K4205002090
Decal, caution to noise



Caution to Noise Decal_001

Decal on Reading Owner's Operating Manual

K4205001560
Decal, read Owner's Operating Manual

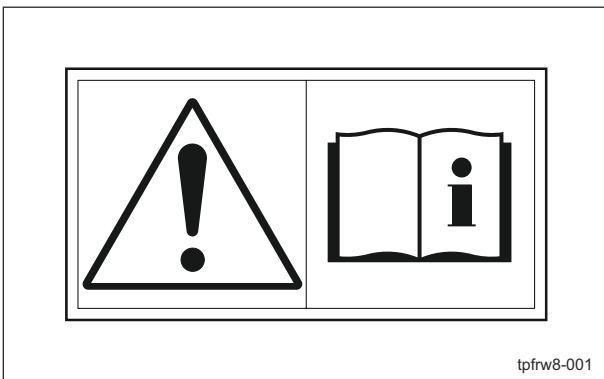
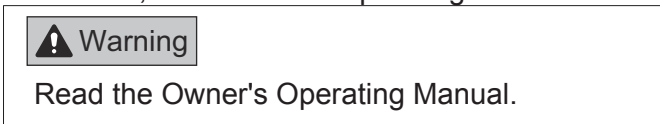

Decal on Reading Owner's Operating Manual_001

Operation Decals

Positions of Operation Decals

■ #21931

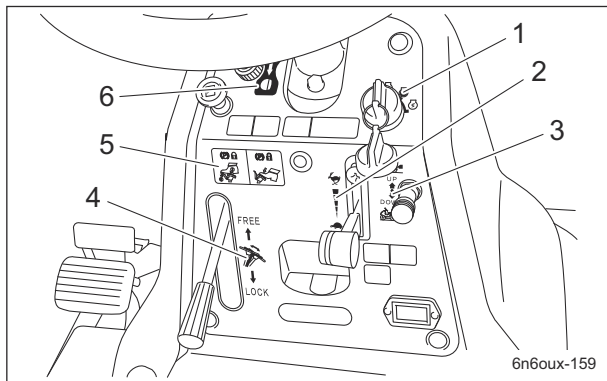

Positions of Operation Decals_001

■ #21932-

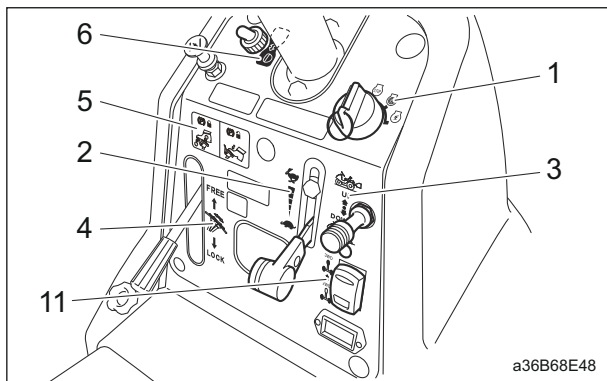

Positions of Operation Decals_002

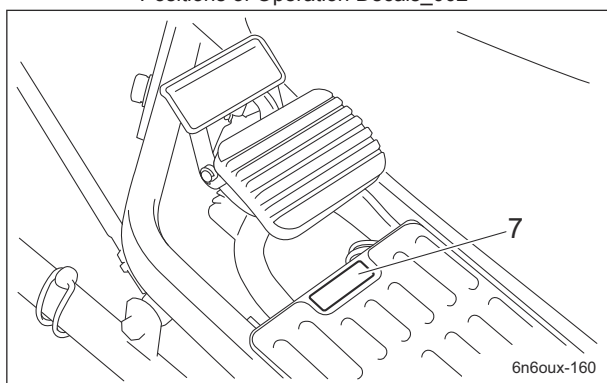

Positions of Operation Decals_003

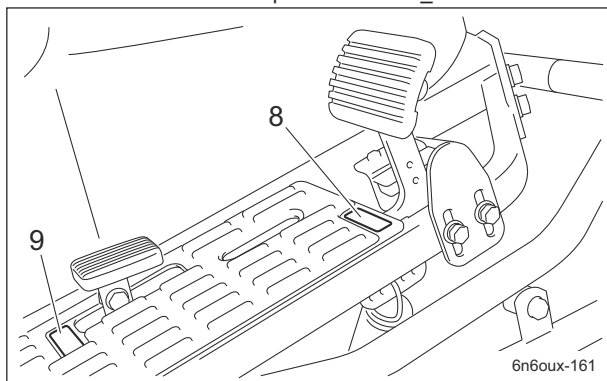

Positions of Operation Decals_004

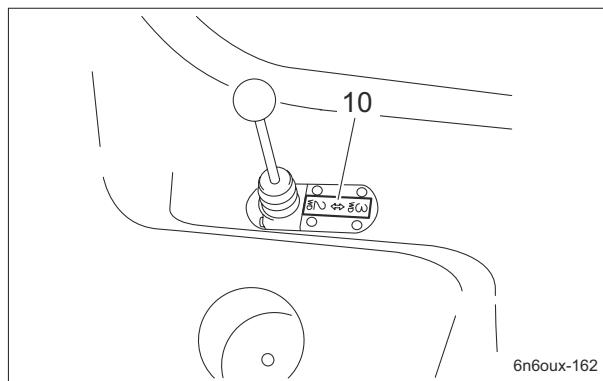

Positions of Operation Decals_005

1	Key switch mark
2	Engine rotation mark
3	Rake up/down mark
4	Tilt steering mark
5	Parking brake mark
6	Light switch mark
7	BRAKE decal
8	FORWARD decal
9	BACKWARD decal
10	2WD/3WD selector lever decal (3WD: #21931)
11	2WD/3WD changeover mark (3WD: #21932-)

Product Overview

Description of Operation Decals

Key Switch Mark

Key switch mark

It illustrates the position of the key switch.

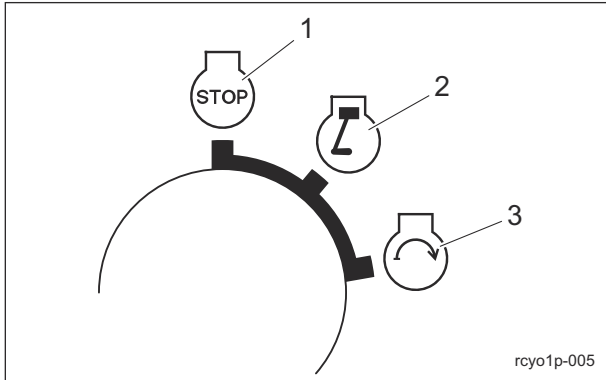

Key Switch Mark_001

1	OFF
2	ON
3	START

Engine Rotation Mark

Engine Rotation mark

This indicates high/low speed of the engine rotation.

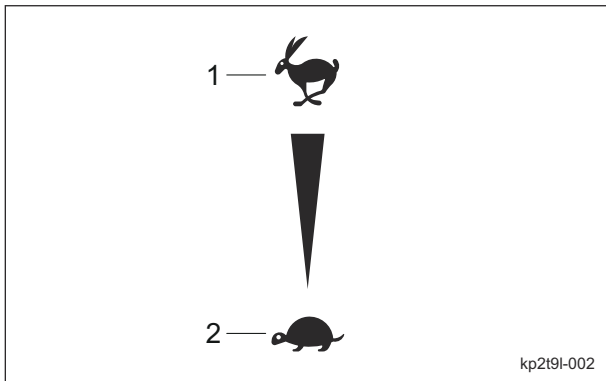

Engine Rotation Mark_001

1	High speed
2	Low speed

Rake Up/Down Mark

Rake up/down mark

This indicates up/down of the rake.

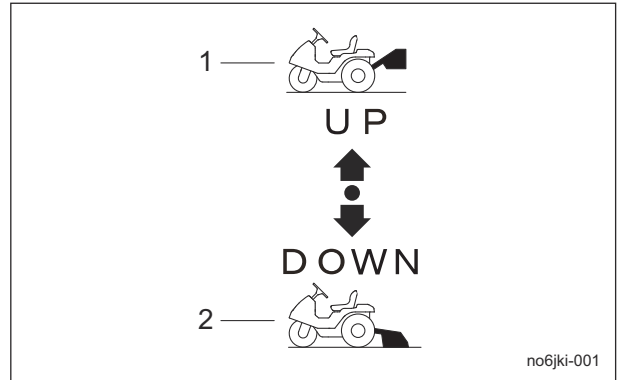

Rake Up/Down Mark_001

1	UP
2	DOWN

Tilt Steering Mark

Tilt steering mark

This indicates the direction of tilt steering and lock/free of the position.

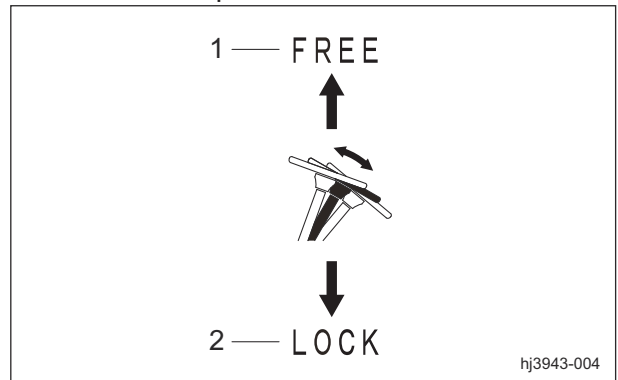

Tilt Steering Mark_001

1	FREE
2	LOCK

Product Overview

Parking Brake Mark

Parking brake mark
This indicates lock/release of the parking brake.

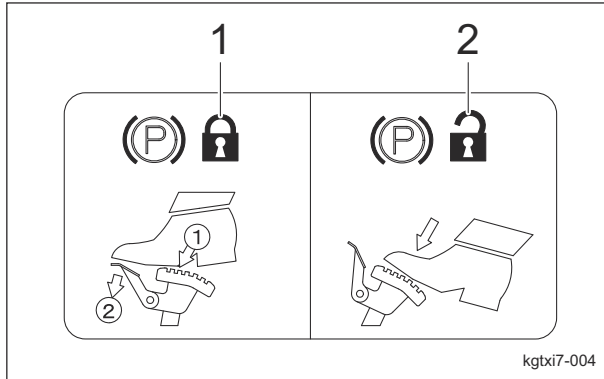

Parking Brake Mark_001

1	Lock
2	Release

Light Switch Mark

Note:
Depending on the specifications, this function may not be available.

K4203001410
STICKER, LIGHT SWITCH
This indicates the light switch positions.

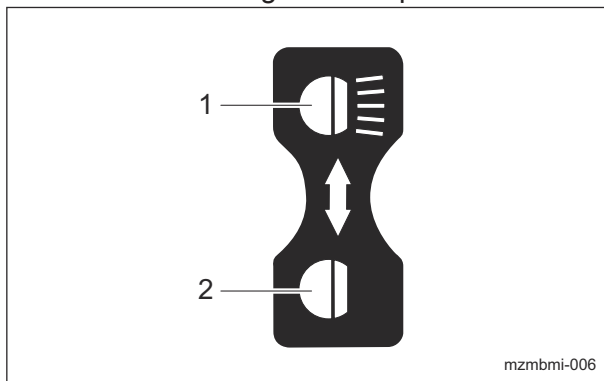

Light Switch Mark_001

1	ON
2	OFF

BRAKE Decal

K4203001450
Decal, BRAKE
This indicates brake.



BRAKE Decal_001

FORWARD Decal

K4203001430
Decal, FORWARD
This indicates forward travel.



FORWARD Decal_001

BACKWARD Decal

K4203001440
Decal, BACKWARD
This indicates backward travel.

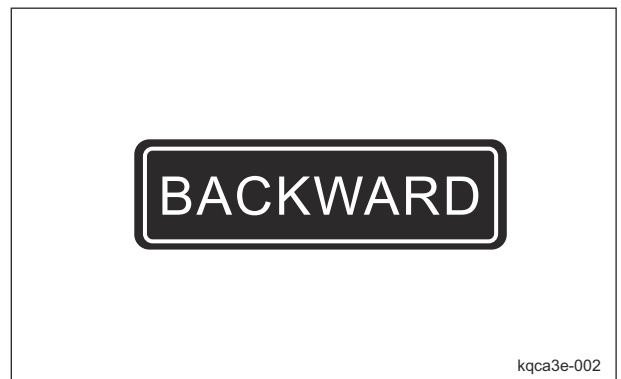

BACKWARD Decal_001

Product Overview

2WD/3WD Selector Lever Decal

Note:

Depending on the specifications, this function may not be available.

K4203001380

Decal, 2WD - 3WD shift lever

This indicates 2WD/3WD changeover.

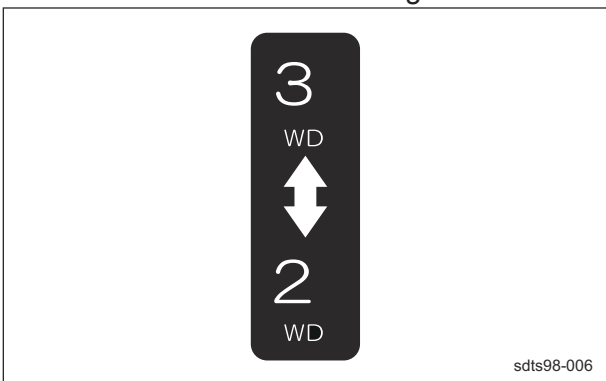

2WD/3WD Selector Lever Decal_001

2WD/3WD Changeover Mark

2WD/3WD changeover mark

This indicates 2WD/3WD changeover.

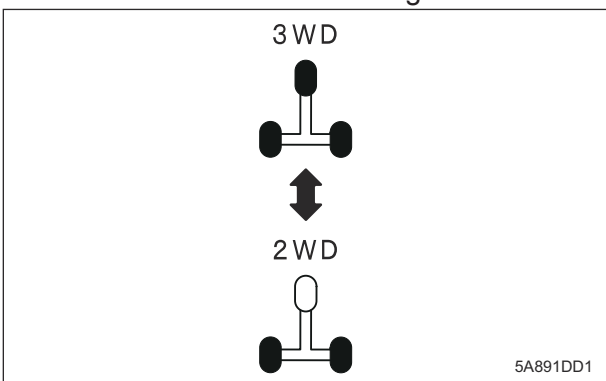

2WD/3WD Changeover Mark_001

Description of Functions

Key Switch	Page 4-2
Throttle Lever	Page 4-2
Choke Lever	Page 4-2
Up/Down Switch Lever	Page 4-3
2WD/3WD Selector Lever	Page 4-3
2WD/3WD Selector Switch	Page 4-4
Light Switch	Page 4-4
Traveling Pedal	Page 4-4
Brake Pedal	Page 4-5
Broom Holder	Page 4-5
Cargo Box	Page 4-5
Instruments on The Operation	
Panel	Page 4-6
Hour Meter	Page 4-6
Safety Device	Page 4-6
Interlock System	Page 4-6
Warning Mechanisms	Page 4-6
Warning Buzzer	Page 4-6

Description of Functions

Key Switch

The key switch is a lock for inserting the ignition key. This is used to start, run and stop the engine by turning the ignition key to change the key switch position.

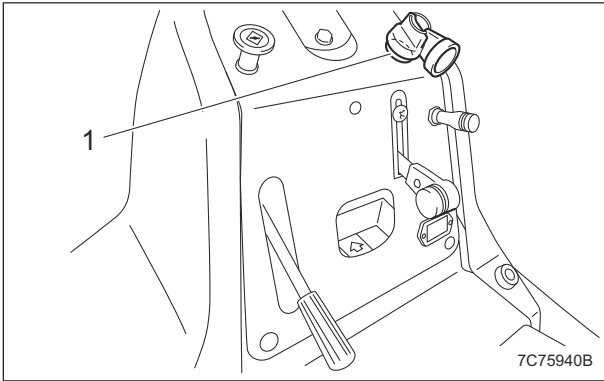

Key Switch_001

1	Key switch
---	------------

Choke Lever

The choke lever is located on the left side below the steering wheel and its knob is to be pulled when starting the engine. Pull the knob half way for restarting, as necessary.

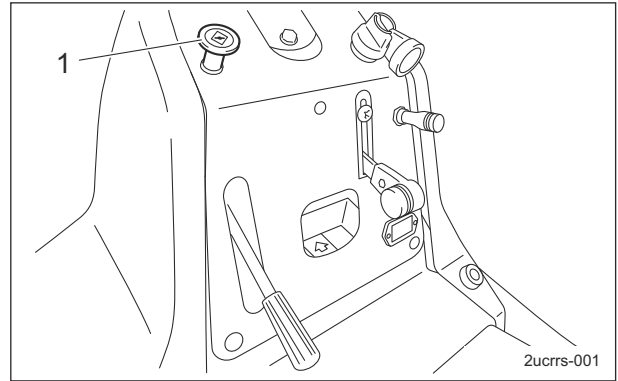

Choke Lever_001

1	Choke lever
---	-------------

Throttle Lever

The throttle lever is located on the right side below the steering wheel and enables you to adjust the engine rpm. Move the throttle lever toward "High speed" to increase the engine rpm, and toward "Low speed" to reduce the rpm.

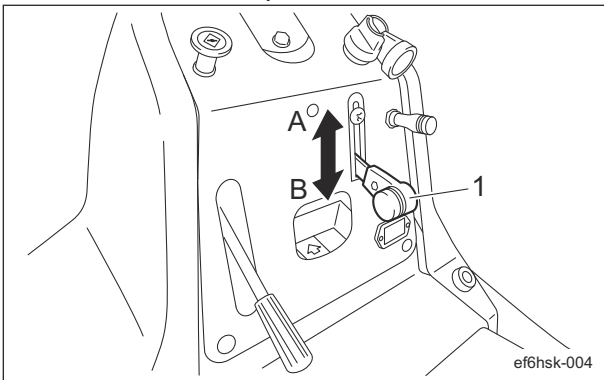

Throttle Lever_001

1	Throttle lever
A	High speed
B	Low speed

Description of Functions

Up/Down Switch Lever

Important

If the engine rpm is low, the rake will not be raised and lowered due to insufficient hydraulic oil.
 Move the throttle lever above the middle position toward "High speed".

The up/down switch lever is on the right side below the steering wheel and is used to operate the rake.

- Shift the up/down switch lever to the "UP" position to raise the rake.
 When the lever is released, it returns to the neutral position and stops there.
- Shift the up/down switch lever to the "DOWN" position to lower the rake.
 When the lever is released, it returns to the neutral position and stops there.

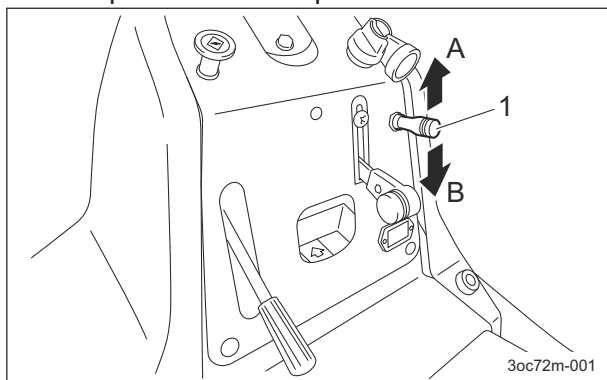

Up/Down Switch Lever_001

1	Up/down switch lever
A	UP
B	DOWN

2WD/3WD Selector Lever

Note:
 Depending on the specifications, this function may not be available.

■ -#21931

Important

When switching between 2WD and 3WD operation, make sure to stop the machine completely.

The 2WD/3WD selector lever is on the right side of the driver's seat and is used to switch the traveling and operation mode.

- Shift the 2WD/3WD selector lever to the "2WD" position to operate in rear-wheel 2WD.
- Shift the 2WD/3WD selector lever to the "3WD" position to operate in all-wheel 3WD.

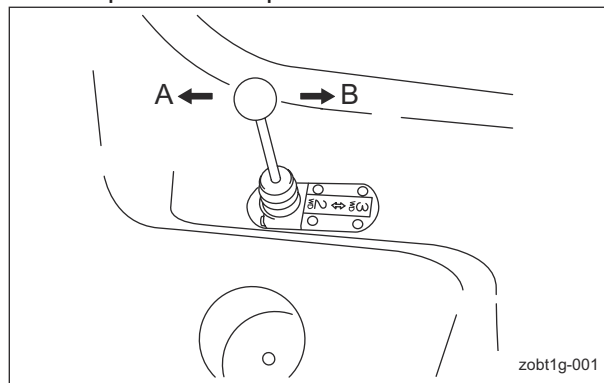

2WD/3WD Selector Lever_001

A	2WD
B	3WD

* Use of 2WD or 3WD

- Use 2WD when working with the blade and high-speed traveling (maximum 16 km/h) is possible.
- Use 3WD when working on steeply sloped or soft bunkers or bunkers with a small diameter.

Description of Functions

2WD/3WD Selector Switch

Warning

In the case of 2WD/3WD model, travel in 2WD mode on steep downward slopes, wet road surface or downward slopes of wet lawn since traveling there in 3WD mode is dangerous. Otherwise, the rear tire going into a skid may cause loss of traveling control.

Important

Do not switch between 2WD and 3WD before the machine stops completely. Otherwise, the hydraulic system will malfunction.

Note:

Depending on the specifications, this function may not be available.

#21932-

1. When the 2WD/3WD selector switch is flipped to the "2WD" position, the vehicle will be 2WD mode.
2. When the 2WD/3WD selector switch is flipped to the "3WD" position, the green LED will light up and the vehicle will be 3WD mode. However, when the engine is turned off, the machine automatically switches to 2WD mode.

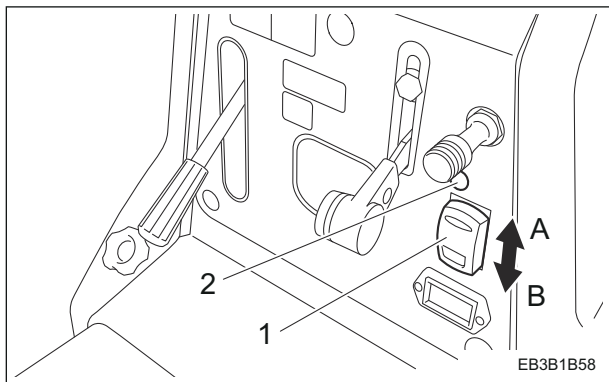

2WD/3WD Selector Switch_001

1	2WD/3WD selector switch
2	LED
A	3WD
B	2WD

Light Switch

Note:

Depending on the specifications, this function may not be available.

Caution

The lights provide auxiliary lighting. Do not travel or operate the machine at night or under poor visibility.

The light switch is located in the operation panel.

Flip the switch up to turn the light on, and down to turn the light off.

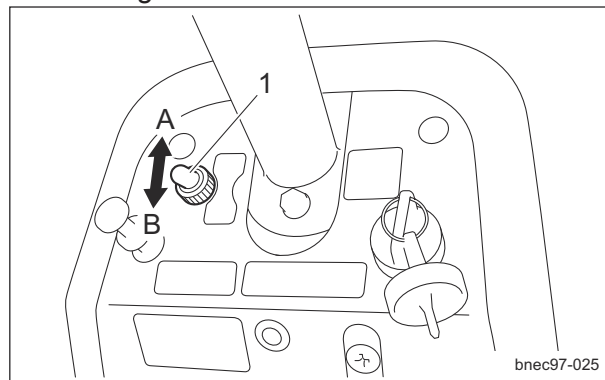

Light Switch_001

1	Light switch
A	ON
B	OFF

Traveling Pedal

The traveling pedal is located in the right foot area.

When depressed "Forward", the machine travels forward. When depressed "Backward", the machine travels in reverse.

If the pedal is secured with the speed adjustment plate during operation, the machine can be operated at a constant speed.

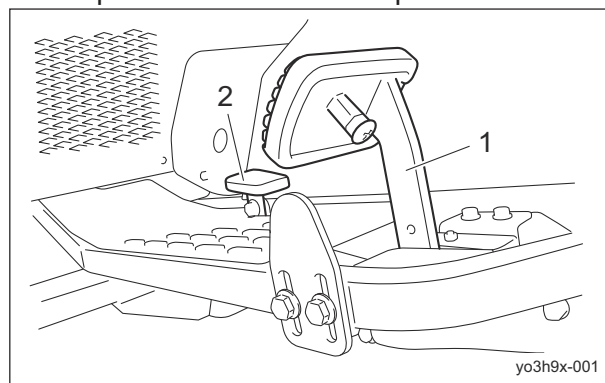

Traveling Pedal_001

1	Forward
2	Backward

Description of Functions

Brake Pedal

Caution

When leaving the driver's seat, park the machine on a stable, flat surface and be sure to apply the parking brake.

Caution

Do not park on a slope.

The brake pedal is located in the left foot area. To stop the machine, depress the brake pedal all the way firmly. When parking, firmly depress the brake pedal and lock it with the lock fitting. To release it, firmly depress the brake pedal and release the lock fitting.

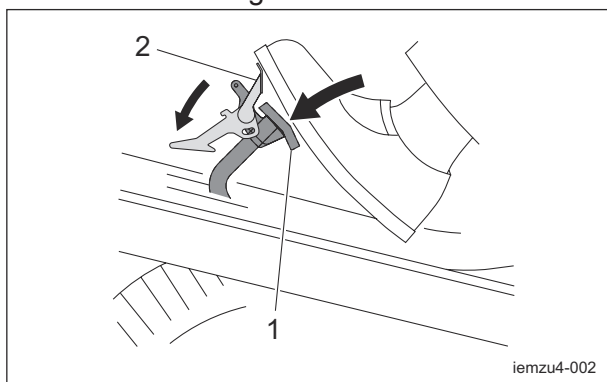

Brake Pedal_001

1	Brake pedal
2	Lock fitting

Broom Holder

Broom and rake can be stored in these holders for transport.

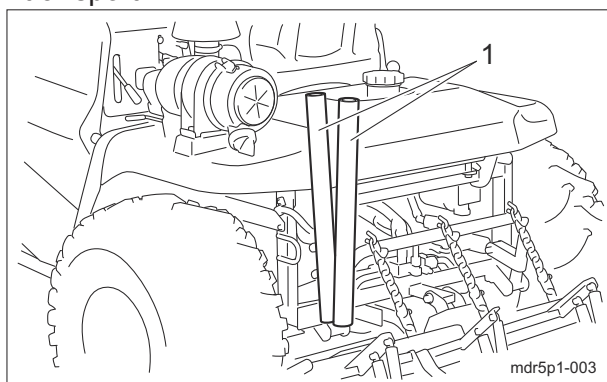

Broom Holder_001

1	Broom Holder
---	--------------

Cargo Box

Note:
Depending on the specifications, this function may not be available.

Important

The maximum loading weight is 15 kg (33.07 lb).

Cargo Box is a container to transport equipments such as a back pack blower which may be used together during cutting work. There are two types of cargo boxes. Small type :

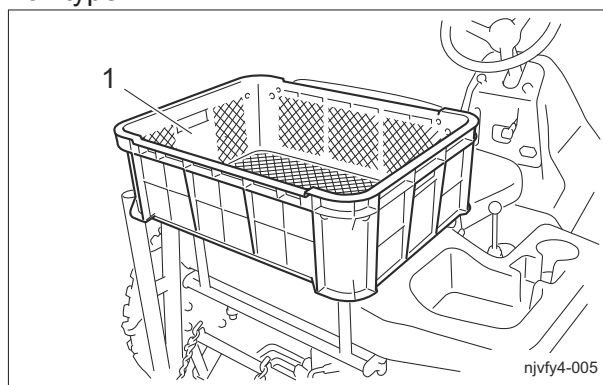

Cargo Box_001

1	Cargo box
---	-----------

Large type :

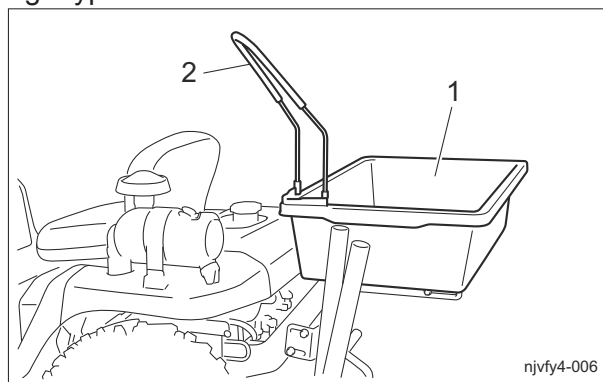

Cargo Box_002

1	Cargo box
2	Blower nozzle holder

Description of Functions

Instruments on The Operation Panel

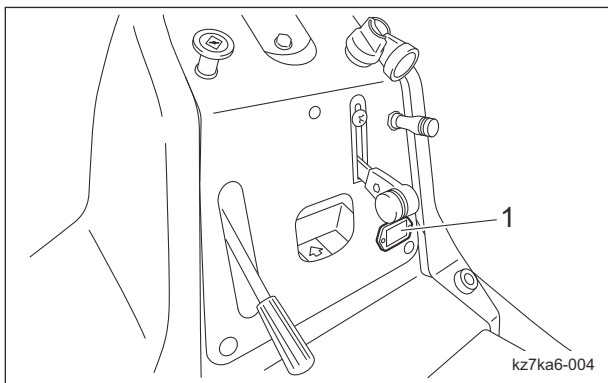

Instruments on The Operation Panel_001

1	Hour meter
---	------------

Hour Meter

The hour meter indicates the accumulated operation time of the engine.

The number in red figures on a white background is incremented every thirty-six seconds.

The number in white figures on a black background is incremented every hour.

1/100 wheel ... red figures on a white background

Hour wheel ... white figures on a black background

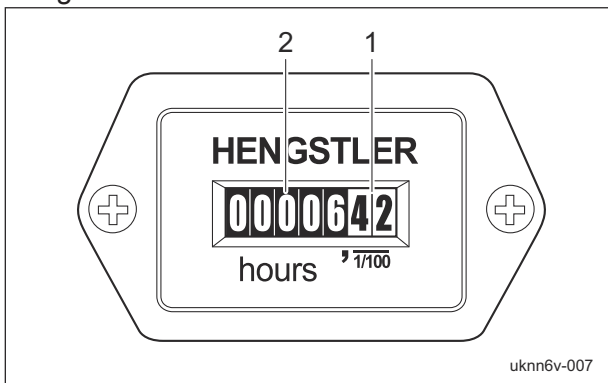

Hour Meter_001

1	1/100 wheel
2	Hour wheel

Safety Device

Interlock System

This machine features an interlock system for starting and stopping the engine.

1. As for starting the engine, the safety device prevents the engine from starting unless it meets each of the following three conditions.

- An operator is sitting on the seat.
- The parking brake is applied.
- The traveling pedal is set to the neutral position.

2. In the event the operator leaves the seat with the parking brake not applied and the engine running, the safety device will be activated and will stop the engine.

3. In the event the operator leaves the seat with the parking brake applied and the engine running, the safety device will be activated and will stop the engine under the following condition.

- The traveling pedal is not set to the neutral position. (The operator has depressed the traveling pedal.)

Warning Mechanisms

Warning Buzzer

1. Warning buzzer against operation with the brake applied

If the traveling pedal is depressed while the parking brake is applied, a buzzer will sound. (intermittent tone)

Release the parking brake when the warning buzzer sounds.

Operations before Service Page 5-2

Procedure to Open/Close Front
Cover Page 5-2

Procedure to Open/Close Rear
Cover Page 5-2

Inspection before Use Page 5-3

EnginePage 5-3

Main Vehicle Page 5-5

Adjustment before Work Page 5-10

Adjustment of Steering Wheel
Position Page 5-10

Adjustment of Seat Position Page 5-10

Mounting and Dismounting Page 5-10

Procedure to Mount/Dismount Page 5-10

Start/Stop of Engine Page 5-11

Procedure to Start EnginePage 5-11

Procedure to Stop Engine Page 5-11

Parking and StoppingPage 5-12

Procedure to Leave The Machine Page 5-12

MovePage 5-12

Traveling Procedure Page 5-12

OperationsPage 5-12

Rake Operation Page 5-12

Blade OperationPage 5-13

Cultivator OperationPage 5-14

Finishing Brush Operation Page 5-15

TransportingPage 5-16

Transporting Procedure Page 5-16

Cleaning after Use Page 5-16

EnginePage 5-16

Main Vehicle Page 5-16

Storage Page 5-16

Short-Term Storage Page 5-16

Handling Instructions

Operations before Service

The following sections describe the preparatory works required before performing the services including inspection, adjustment, cleaning, maintenance and repair.

Procedure to Open/Close Front Cover

Caution

Do not open the cover in strong winds.

Caution

When closing the cover, be careful not to pinch your hands.

1. Procedure to open the front cover

[1] Remove the dimple knobs.

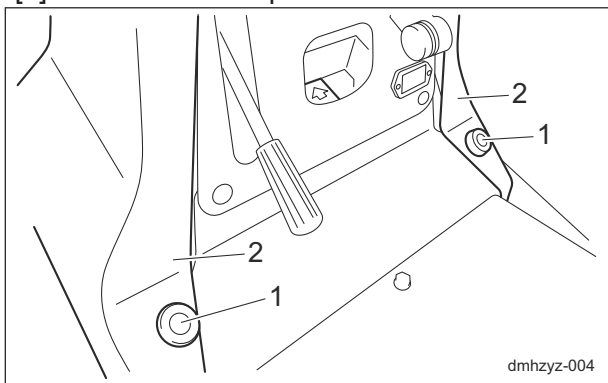

Procedure to Open/Close Front Cover_001

1	Dimple knobs
2	Front cover

[2] Open the front cover, and then tilt it forward until the wire is fully extended.

[3] Make sure that the front cover will not close, and then release it.

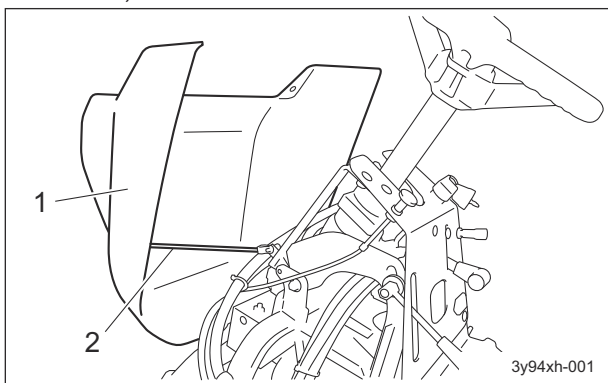

Procedure to Open/Close Front Cover_002

1	Front cover
2	Wire

2. Procedure to close the front cover

[1] Close the front cover slowly.

[2] Install the dimple knobs.

Procedure to Open/Close Rear Cover

Warning

Stop the engine when performing recommended maintenance operations that do not require the engine to start when the rear cover is opened. When performing maintenance with the engine started, stay away from moving parts.

Caution

Do not open the cover in strong winds.

Caution

When closing the cover, be careful not to pinch your hands.

1. Procedure to open the rear cover

[1] Release the cover fastener.

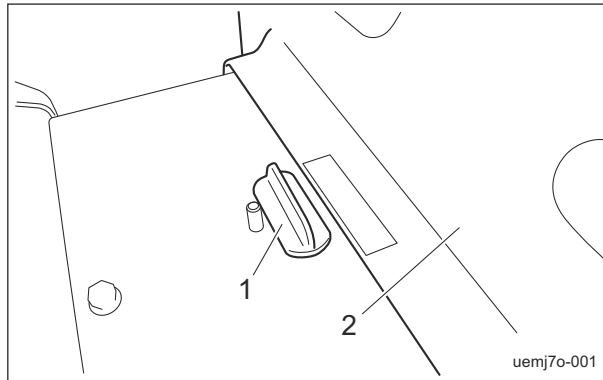

Procedure to Open/Close Rear Cover_001

1	Cover fastener (released)
2	Rear cover

[2] Open the rear cover, and then lift it until the gas spring is fully extended.

Handling Instructions

[3] Make sure that the rear cover will not close, and then release it.

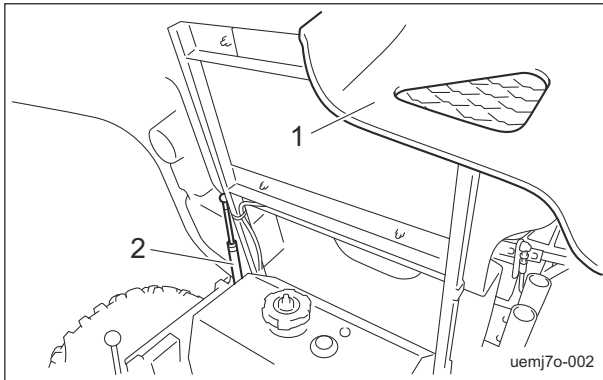

Procedure to Open/Close Rear Cover_002

1	Rear cover
2	Gas spring

2. Procedure to close the rear cover

[1] Slowly lower the rear cover while firmly supporting it.

[2] Engage the cover fastener.

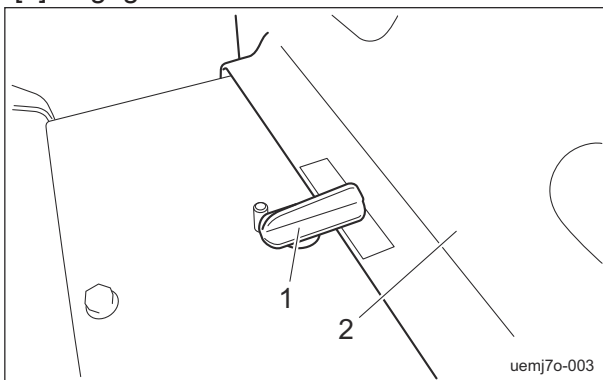

Procedure to Open/Close Rear Cover_003

1	Cover fastener (engaged)
2	Rear cover

Inspection before Use

The purpose of the machine inspection is to:

- Prevent accidents
- Prevent damage to the machine
- Maintain machine performance

Detecting machine malfunctions early helps prevent unexpected problems from occurring. If you detect any abnormalities with the machine, immediately perform maintenance or repairs.

Engine

Inspection of Engine Oil

Important

Securely insert the oil level gauge.

Check the contamination of oil and engine oil level to inspect the engine oil. Inspect the engine oil level 10 to 20 minutes after stopping the engine.

1. Place the machine so that the engine is level.
2. Stop the engine.
3. Open the rear cover.
4. Pull out the oil level gauge.

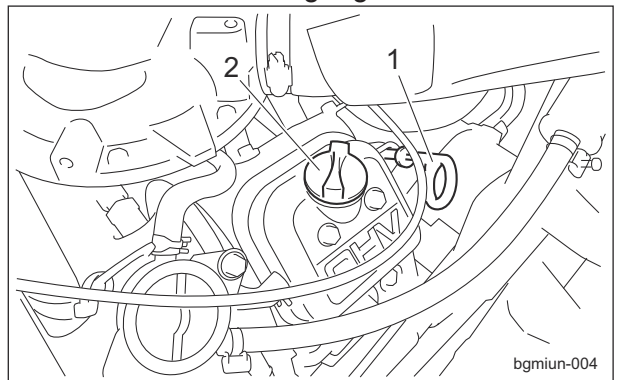

Inspection of Engine Oil_001

1	Oil level gauge
2	Oil filler cap

5. Wipe the oil off the oil level gauge cleanly with papers or cloths.
6. After wiping the oil off the oil level gauge, check the contamination.
7. Return the oil level gauge to its original position, insert tightly, and pull out again.

Handling Instructions

8. Check the engine oil level.

The appropriate oil level should be between the upper and lower limit lines on the gauge.

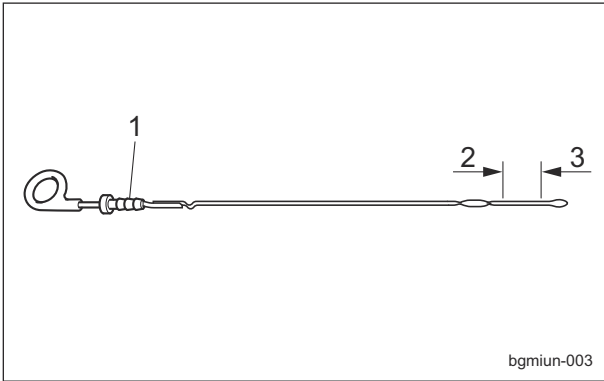

Inspection of Engine Oil_002

1	Oil level gauge
2	Upper limit
3	Lower limit

9. Return the oil level gauge to its original position, and insert it tightly.

10. Close the rear cover.

Inspection of Fuel Quantity

With the machine on a level surface, observe the fuel gauge on the fuel tank to check the fuel level.

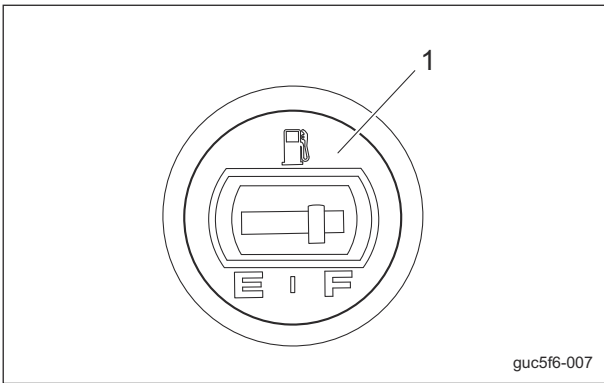

Inspection of Fuel Quantity_001

1	Fuel gauge
---	------------

Supply of Fuel

Warning

Supply fuel before starting the engine. Never remove the tank cap or supply fuel while the engine is running. When opening the tank cap, wait at least 1 minute after stopping the engine, and then slowly open the cap to release the pressure in the tank. Opening the tank cap quickly may cause fuel to burst out.

Warning

Do not supply fuel above FULL level of the fuel gauge. If you supply too much fuel, it might overflow from the fuel cap when you travel or work on a slope.

Warning

Keep fire away while refueling. Do not smoke while refueling.

Warning

Supply fuel after the engine is stopped and has well cooled down.

If the fuel gauge located on the fuel tank indicates a level close to E (EMPTY), supply gasoline at your earliest convenience.

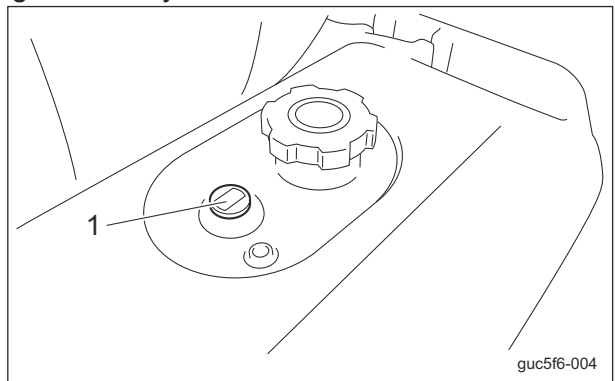

Supply of Fuel_001

1	Fuel gauge
---	------------

Handling Instructions

The fuel tank capacity up to the red ring of strainer is approximately 15.0 dm³ (15.0 L).

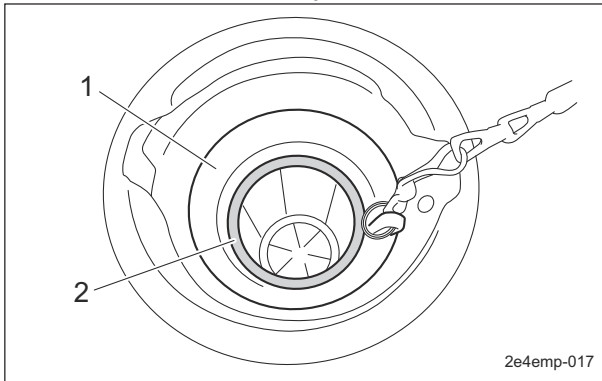

Supply of Fuel_002

1	Strainer
2	Red ring

1	Outer element
2	Inner element
3	Clip
4	Cover
5	Air cleaner body

Main Vehicle

Inspection of Engine-Associated Parts

⚠ Caution

Perform operations after the muffler, engine and other parts have sufficiently cooled. Otherwise, you may get burned.

1. Check for damages and dirt.
2. Check the mount for looseness and cracks.
3. Check for liquid leakage.
4. Check on and around the muffler for grass clippings and flammable materials.

Inspection of Hydraulic Oil

1. Lower the rake and maintain that position on a level surface.
2. Make sure that the oil level is at the middle of the oil gauge.

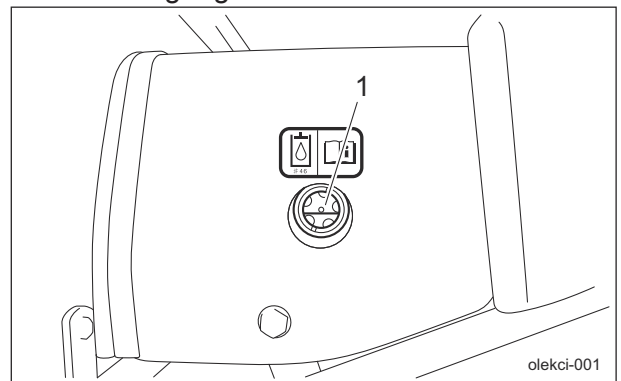

Inspection of Hydraulic Oil_001

1	Oil gauge
---	-----------

Inspection of Fuel Filter

1. Make sure that there is no fuel leakage.
2. Make sure that the filter is not damaged.
3. Make sure that the filter is not contaminated.

Inspection of Fuel Strainer

1. Make sure that there is no fuel leakage.
2. Make sure that the fuel strainer is not damaged or dirty.

Inspection of Air Cleaner

Clean or replace the air cleaner element as necessary.

1. Make sure that the outer element is neither damaged nor dirty.
2. Make sure that the inner element is neither damaged nor dirty.

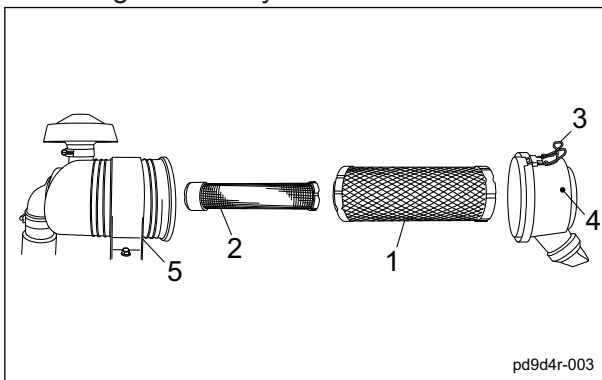

Inspection of Air Cleaner_001

3. Check underneath the machine for oil leakage.

Handling Instructions

Inspection of Tires

1. Check the pneumatic pressure of the tires.
2. Make sure that there are no cracks, damage or abnormal wear.

Tire size	Pneumatic pressure
Front wheel (PD21 x 11.00 - 10)	70 kPa (0.7 kgf/cm ²)
Rear wheel (25 x 13.00 - 9)	40 kPa (0.4 kgf/cm ²)

Inspection of Battery

Danger

Keep away from fire while inspecting or charging the battery.
The battery may explode.

Caution

Implement after the engine and muffler etc. have well cooled down.
Otherwise, you may get burned.

Important

Be sure to stop the engine before inspecting or charging the battery.

Battery inspection items are described below.

1. Inspecting the exterior
Visually inspect the exterior of the battery, and check that there are no cracks, splits, missing sections, or abnormal deformation in the battery case, and that there is no electrolyte leaking.
If abnormalities are found, immediately replace the battery.

2. Cleaning the exterior

Warning

Do not clean the battery with a dry cloth. Cleaning the battery with a dry cloth may cause it to catch fire or explode due to static electricity.

Use a wet cloth for cleaning.

Inspect the vent plugs or vent holes on the side of the battery, and if they are blocked by dirt wash them with water to remove the blockage.

Continuing to use the battery with the vent holes blocked may cause the battery to rupture from increased internal pressure due to gases generated inside the battery.

3. Inspecting the mounting bracket
Inspect whether the battery is secured firmly with the mounting bracket.
If the bracket is loose, tighten the mounting bracket nuts until the battery is secured firmly.
An improperly mounted battery may cause damage to the battery case or electrolyte leaks due to the battery moving with vibrations while traveling.
4. Inspecting the cable terminals
If the connection between the battery terminals and vehicle's cable terminals are loose, tighten the nuts until the cable terminals are secured firmly.
Insufficiently tightened terminals may result in poor battery charging, damage to the terminals due to poor contacts, or an explosion.
If the terminals are corroded, rub them clean with a wire brush or fine grit sandpaper, and lightly apply anti-rust grease.

Handling Instructions

5. Inspecting the electrolyte level and refilling

Warning

Do not allow the battery fluid level to become lower than the LOWER LEVEL (minimum fluid level line).

The battery may explode if it is used or charged while the battery fluid level is at the LOWER LEVEL (minimum fluid level line).

Warning

When refilling, do not fill purified water above the UPPER LEVEL line.

Doing so may result in electrolyte leaks.

Clean the areas around the battery fluid level lines using a cloth damped with water to check the electrolyte level from the side of the battery.

Make sure that the battery fluid level is between the UPPER LEVEL (maximum fluid level line) and the LOWER LEVEL (minimum fluid level line).

Refill with purified water up to the UPPER LEVEL line if the level is lower than halfway between the UPPER LEVEL and LOWER LEVEL lines.

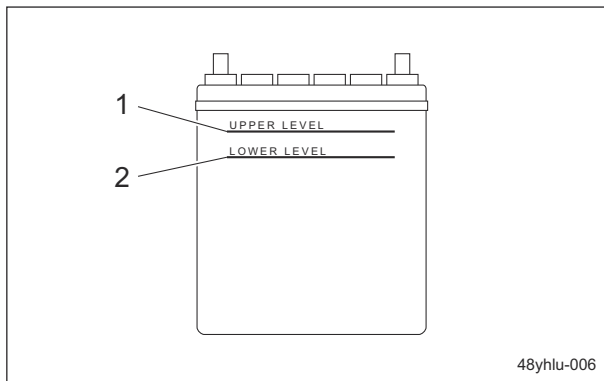

Inspection of Battery_001

1	UPPER LEVEL line
2	LOWER LEVEL line

Inspection of Oil Cooler for Hydraulic Oil

1. Make sure that there is no damage to the oil cooler.
2. Make sure that the oil cooler is not contaminated.

Inspection of Covers

Warning

If you have removed a protective cover during inspection, be sure to securely install it in its original position.

If a protective cover remains removed, foreign objects may fly off, and the operator or the mechanic can be injured.

1. Make sure that there is no wear or deterioration of protective covers.
2. Make sure that there is no damage to protective covers.
3. Make sure that there is no interference with moving parts due to deformation of protective covers.
4. Make sure that protective covers are installed in their appropriate positions.

Inspection of Wire

1. Make sure that the wire is not cracked or damaged.
2. Make sure that the wire is not worn.
3. Make sure that the wire is not crushed.
4. Make sure that the wire is not bent.
5. Make sure that the wire is not corroded or rusted.

Inspection of Traveling Pedal

1. Make sure that there is no play in the pedal.
2. Make sure that the pedal moves smoothly.
3. Make sure that there is no abnormal sound when the pedal is depressed.

Inspection of Brake Pedal

1. Make sure that there is no play in the pedal.
2. Make sure that the pedal moves smoothly.
3. Make sure that there is no abnormal sound when the pedal is depressed.
4. Make sure that the pedal does not touch the floorboard when the pedal is depressed.

Handling Instructions

Inspection of Parking Brake

1. Depress the locking pedal while firmly depressing the brake pedal to lock it and check that the brake is applied effectively.
2. Firmly depress the brake pedal and release the locking pedal to release the brake pedal, and then check that the brake is not applied.

Inspection of Steering Wheel

1. Make sure that there is no play in the steering wheel.
2. Make sure that the steering wheel can be turned smoothly without abnormal noise, etc.
3. Make sure that the steering chain is not overtightened and is not loose.
4. Make sure that there are no cracks, damage or abnormal wear in the steering chain.

Inspection of Liquid Leakage

Important

After approximately 50 hours of operation, some tightened portions may be loosened and liquid such as oil may leak.
Be sure to retighten the parts.

Important

Repair the machine before operation if liquid leakage found.
Ignoring leakage will cause further trouble.

1. Check the bottom of the machine for leakage of liquid such as oil, water, fuel, etc.
2. Locate the leakage and identify the type of liquid.

Inspection of Bolts and Nuts

Important

The bolts and nuts may be loosened at the earlier stage of the use.
Be sure to retighten or replace before operating the machine whenever there is any abnormality.

1. Check the bolts and nuts for looseness and coming off.

2. Check the bolts and nuts for cracks and damages.
3. Check the bolts and nuts for rust.
4. Check around the bolts and nuts for traces of rust fluid.
5. Check for unequal bolt length.
6. Check the bolts and nuts for stripped threads and abrasion.

Inspection of Hour Meter

1. Check the hour meter is not damaged.
2. Check the hour meter operates correctly.
 - [1] Switch the ignition key to the "ON" position.
 - [2] Check the displayed number increases correctly.
 - [3] Switch the ignition key to the "OFF" position.

Inspection of Safety Device

Repair the machine before operation whenever there is any abnormality.

1. Interlock system
Make sure that the interlock system operates correctly.
"Interlock System" (Page 4-6)
2. ROPS
(If the machine is equipped with ROPS and a seat belt)
Make sure that the ROPS is not damaged or broken.
3. Seat belt
(If the machine is equipped with ROPS and a seat belt)
Make sure that the seat belt is not damaged or broken.

Inspection of Rake

Caution

Wear gloves when touching a fork prong bar.

1. Make sure that the rake pipe is not bent.
2. Make sure that the cross-link chain is not twisted or worn.
3. Make sure that the rake shaft is not worn.
4. Make sure that the center shaft of the fulcrum swing fitting is not worn.
5. Make sure that a spring pin is not missing from the rake shaft.

Handling Instructions

6. Make sure that a hardened flat-head pin on the rake hanging arm is not worn.
7. Make sure that the plate springs are not cracked or bent.
8. Make sure that a spring pin is not missing from the rake fulcrum fitting.
9. Make sure that the rake mounting bracket is not bent.
10. Make sure that the smoother plate is not bent, cracked or unevenly worn.
11. Make sure that the warp board is not bent, cracked or worn.
12. Make sure that the fork prong bar is not bent or worn.

5. Make sure that the small blade is not bent, cracked or worn.

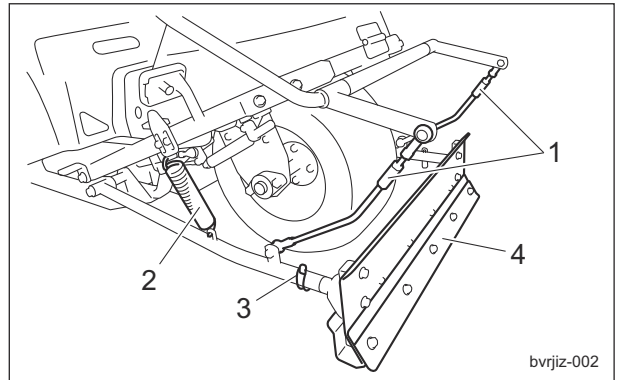

Inspection of Blade_002

1	Connecting shaft
2	Hook spring
3	Delta pin
4	Small blade

Inspection of Blade

Note:

Depending on the specifications, this function may not be available.

1. Make sure that the spring pin is not missing from the lever arm.

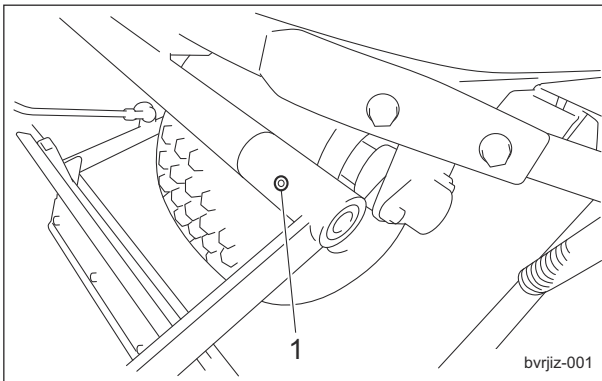

Inspection of Blade_001

1	Spring pin
---	------------

2. Make sure that the connecting shaft is not bent.
3. Make sure that the hook spring is not bent or stretched.
4. Make sure that a delta pin is not missing.

Inspection of Cultivator

Note:

Depending on the specifications, this function may not be available.

1. Make sure that the cultivator wire is not broken.
2. Make sure that the free lock pin is not missing.
3. Make sure that the parker clamp is not loose.
4. Make sure that the trapezoidal cultivator fitting is not worn.

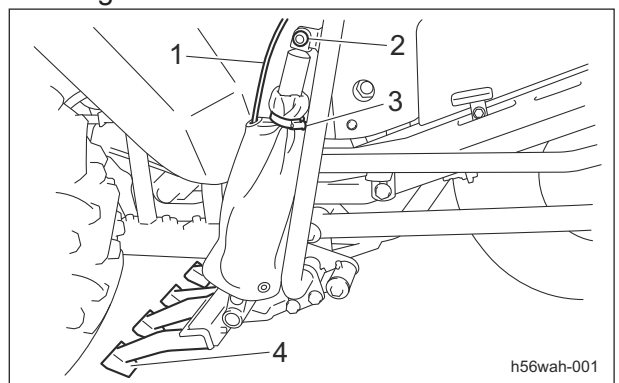

Inspection of Cultivator_001

1	Cultivator wire
2	Free lock pin
3	Parker clamp
4	Trapezoidal cultivator fitting

Handling Instructions

Inspection of Finishing Brush

Note:

Depending on the specifications, this function may not be available.

1. Make sure that the brush mounting frame is not bent.
2. Make sure that the brush is not bent or excessively worn.

Adjustment before Work

Adjustment of Steering Wheel Position

Warning

Since it is dangerous, do not adjust the steering wheel while traveling.

Caution

Be sure the steering wheel position is securely locked. It may result in an unexpected accident if it becomes loose while traveling.

The steering wheel position can be adjusted up or down with the tilt lever.

Adjust the position according to the operator's body size.

Shift the tilt lever to the "FREE" position, move the steering wheel to the position that suits your work requirements, and then shift the tilt lever to the "LOCK" position to secure the steering wheel in place.

The tilt lever is located at the center of the driver's seat.

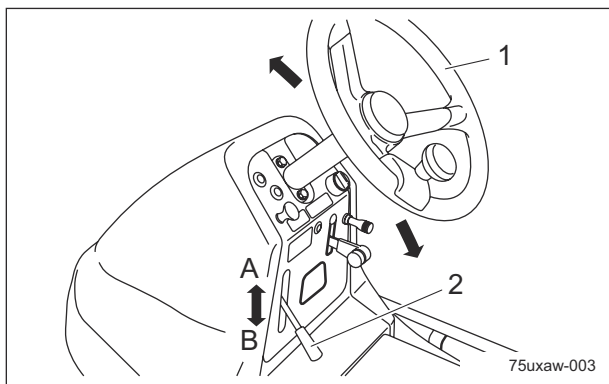

Adjustment of Steering Wheel_001

1	Steering wheel
2	Tilt lever
A	FREE
B	LOCK

Adjustment of Seat Position

Warning

Since it is dangerous, do not adjust while traveling.

Use the seat adjustment lever to adjust the seat position back and forth.

Adjust the position according to the operator's body size.

The adjustment lever is located beneath the front part of the seat.

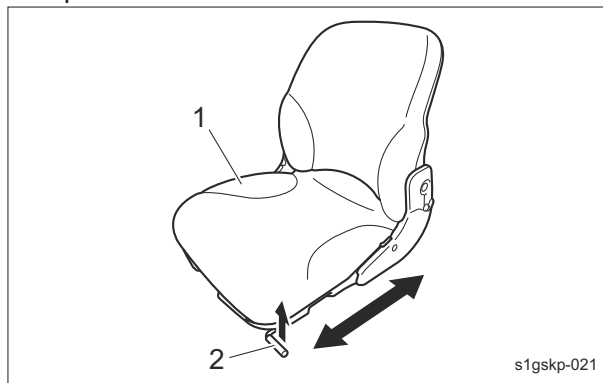

Adjustment of Seat Position_001

1	Seat
2	Adjuster lever

Mounting and Dismounting

Procedure to Mount/Dismount

Caution

Do not step on the tire when mounting/dismounting.

Place your foot on the step on the frame when mounting and dismounting the machine.

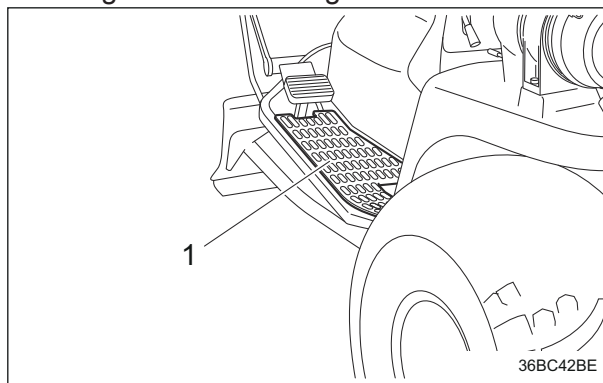

Procedure to Mount/Dismount_001

1	Step
---	------

Handling Instructions

Start/Stop of Engine

Procedure to Start Engine

Caution

Do not start the engine in a building with insufficient ventilation.

Caution

Before starting the engine, make sure that there are no other people or obstacles around the machine.

Caution

Make sure that the covers are correctly in place and are not damaged.

Important

Starter operation must take 15 seconds or less. If the engine does not start, stop using the battery for 30 to 60 seconds to avoid exhausting the battery.

1. Open the fuel cock.
This locates near the fuel tank.

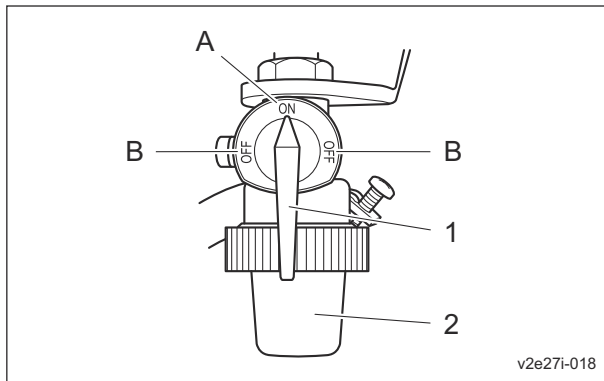

Procedure to Start Engine_001

1	Fuel cock
2	Fuel filter
A	ON (OPEN)
B	OFF (CLOSE)

2. Sit on the seat.
3. Make sure that the parking brake is applied.
4. Make sure that the traveling pedal is in neutral position.
5. Move the throttle lever to the middle position between "High" and "Low".

6. Pull the choke lever.
Pull the choke lever half way for restarting, as necessary.
7. Switch the ignition key to the "START" position.

Important

Quickly returning the ignition key from the "START" position to the "ON" position may result in damage to the machine.

8. When the starter starts rotating and the engine starts, slowly return the ignition key to the "ON" position.
9. Check that the engine has started, and then return the choke lever to its original position.
10. Shift the throttle lever to "Low", and then warm up the engine.
Approximate warming-up time
 - 3 to 5 minutes when the outside temperature is less than 20 degrees Celsius (68 °F)
 - 2 to 3 minutes when the outside temperature is 20 degrees Celsius (68 °F) and over

Procedure to Stop Engine

1. Raise the rake section.
2. Raise the attachment if any installed.
3. Set the traveling pedal in neutral position.
4. Apply the parking brake.
5. Move the throttle lever to "Low", and continue idling for 1-2 minutes.
6. Switch the ignition key to the "OFF" position.
7. Make sure that the engine has stopped.

Handling Instructions

Parking and Stopping

Procedure to Leave The Machine

Caution

If the brakes are not sufficiently effective, use the wheel stoppers to secure the machine.

Caution

Never park the machine on a slope.

1. Park the machine on level ground.
2. Apply the parking brake.
3. Stop the engine.
4. Remove the ignition key.
5. Step off the machine.
6. Close the fuel cock.

Move

Traveling Procedure

Caution

Under any circumstances drive the machine at such a speed that you can stop it immediately for emergencies.

Important

Do NOT start to move or stop the machine abruptly. It will damage the hydraulic system or result in oil leakage.

1. Start the engine.
"Procedure to Start Engine" (Page 5-11)
2. Make sure that the rake section is raised.
3. Make sure that all the attachments are raised if any installed.
4. Gradually move the throttle lever towards "High Speed" position.
5. Firmly depress the brake pedal and release the lock fitting to release the brake pedal.
6. Slowly depress the traveling pedal.
7. The machine starts traveling.
8. Release the traveling pedal and depress the brake pedal to stop the machine.

Operations

Rake Operation

Caution

Perform operations at an appropriate speed for the site and location.

Caution

Before starting operations, check that the area where the operations are to be performed is safe.

Caution

Before raising or lowering the rake, make sure that there are no people around the rake.

Important

Do NOT start to move or stop the machine abruptly. It will damage the hydraulic system or result in oil leakage.

1. Start the engine.
"Procedure to Start Engine" (Page 5-11)

Important

If the engine rpm is low, the rake will not be raised and lowered due to insufficient hydraulic oil. Move the throttle lever above the middle position toward "High speed".

2. Make sure that the rake section is raised.
3. Make sure that all the attachments are raised if any installed.
4. Move the throttle lever toward "High speed" to rev up the engine to MAX.
5. Firmly depress the brake pedal and release the lock fitting.
The parking brake is released at the same time.

Handling Instructions

Caution

Do not enter or leave a bunker via a steep slope or extremely uneven ground.

Important

When switching between 2WD and 3WD operation, make sure to stop the machine completely.

6. Enter the bunker.

Important

Do not back up with the rake, cultivator or finishing brush lowered.

- 7. Depress the traveling pedal to travel.
- 8. At the bunker area where the operation is to be started, shift the up/down switch lever to the "DOWN" position to lower the rake.
- 9. At the bunker area where the operation is to be stopped, shift the up/down switch lever to the "UP" position to raise the rake.
- 10. Leave the bunker.
- 11. If tire tracks remain, use the broom to remove them.

Blade Operation

Caution

Perform operations at an appropriate speed for the site and location.

Caution

Before starting operations, check that the area where the operations are to be performed is safe.

Caution

Before raising or lowering the rake, make sure that there are no people around the rake.

Caution

If the blade is raised, do not touch the lifting lever.

Caution

When getting on and off the machine, watch out the blade lever lest you should get your foot caught on it and fall.

Important

Do NOT start to move or stop the machine abruptly. It will damage the hydraulic system or result in oil leakage.

- 1. Start the engine.
"Procedure to Start Engine" (Page 5-11)

Important

If the engine rpm is low, the rake will not be raised and lowered due to insufficient hydraulic oil. Move the throttle lever above the middle position toward "High speed".

- 2. Make sure that the rake section is raised.
- 3. Make sure that all the attachments are raised if any installed.
- 4. Move the throttle lever toward "High speed" to rev up the engine to MAX.
- 5. Firmly depress the brake pedal and release the lock fitting.
The parking brake is released at the same time.

Caution

Do not enter or leave a bunker via a steep slope or extremely uneven ground.

Important

When switching between 2WD and 3WD operation, make sure to stop the machine completely.

6. Enter the bunker.

Handling Instructions

Important

Perform blade operations in 2WD.

7. Set the drive setting to 2WD mode (rear-wheel 2WD).

Important

Do not back up with the rake, cultivator or finishing brush lowered.

8. Depress the traveling pedal to travel.

9. At the bunker area where the operation is to be started, repeatedly perform the following operations.

- Move the blade lever forward to lower the blade, and then keep pushing the blade lever forward to lift the sand while driving forward.
- Pull the blade lever toward you to raise the blade.

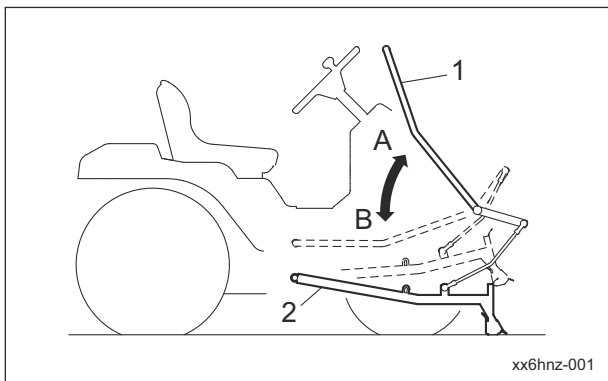

Blade_005

1	Blade lever
2	Blade
A	Tilted up (blade lowered)
B	Pulled down (blade raised)

Cultivator Operation

Caution

Perform operations at an appropriate speed for the site and location.

Caution

Before starting operations, check that the area where the operations are to be performed is safe.

Important

Do NOT start to move or stop the machine abruptly. It will damage the hydraulic system or result in oil leakage.

1. Start the engine.
"Procedure to Start Engine" (Page 5-11)

Important

If the engine rpm is low, the rake will not be raised and lowered due to insufficient hydraulic oil. Move the throttle lever above the middle position toward "High speed".

2. Make sure that the rake section is raised.
3. Make sure that all the attachments are raised if any installed.
4. Move the throttle lever toward "High speed" to rev up the engine to MAX.
5. Firmly depress the brake pedal and release the lock fitting.
The parking brake is released at the same time.

Caution

Do not enter or leave a bunker via a steep slope or extremely uneven ground.

Important

When switching between 2WD and 3WD operation, make sure to stop the machine completely.

6. Enter the bunker.

Important

Do not back up with the rake, cultivator or finishing brush lowered.

7. Depress the traveling pedal to travel.

Handling Instructions

8. At the bunker area where the operation is to be started, squeeze the clutch lever and pull the cultivator lever toward you.

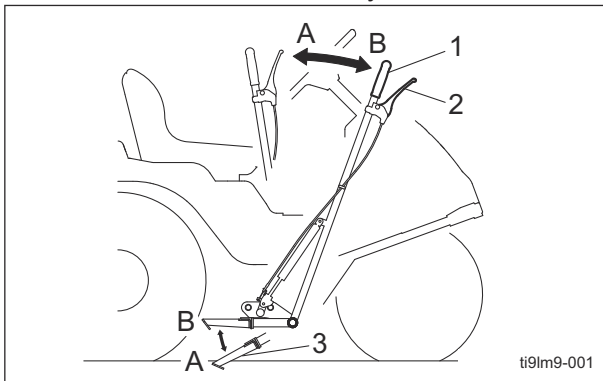

Cultivator_004

1	Cultivator lever
2	Clutch lever
3	Cultivator board
A	Pull (lowered)
B	Push (raised)

9. Lower the cultivator board to the desired depth, and then release the clutch lever.
10. At the bunker area where the operation is to be stopped, squeeze the clutch lever and push the cultivator lever to raise the cultivator board.
11. At the bunker area where the operation is to be started, shift the up/down switch lever to the "DOWN" position to lower the rake.
12. At the bunker area where the operation is to be stopped, shift the up/down switch lever to the "UP" position to raise the rake.
13. Leave the bunker.
14. If tire tracks remain, use the broom to remove them.

Finishing Brush Operation

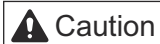

Perform operations at an appropriate speed for the site and location.



Before starting operations, check that the area where the operations are to be performed is safe.

Important

Do NOT start to move or stop the machine abruptly. It will damage the hydraulic system or result in oil leakage.

1. Start the engine.
"Procedure to Start Engine" (Page 5-11)

Important

If the engine rpm is low, the rake will not be raised and lowered due to insufficient hydraulic oil. Move the throttle lever above the middle position toward "High speed".

2. Make sure that the rake section is raised.
3. Make sure that all the attachments are raised if any installed.
4. Move the throttle lever toward "High speed" to rev up the engine to MAX.
5. Firmly depress the brake pedal and release the lock fitting.
The parking brake is released at the same time.



Do not enter or leave a bunker via a steep slope or extremely uneven ground.

6. Enter the bunker.
7. Stop the machine and apply the parking brake.

Important

When switching between 2WD and 3WD operation, make sure to stop the machine completely.

8. Adjust the height of the brush from the ground according to the bunker conditions.
9. Release the parking brake.

Important

Do not back up with the rake, cultivator or finishing brush lowered.

10. Depress the traveling pedal to travel.

Handling Instructions

11. At the bunker area where the operation is to be started, shift the up/down switch lever to the "DOWN" position to lower the rake. The finishing brush is lowered at the same time.
12. At the bunker area where the operation is to be stopped, shift the up/down switch lever to the "UP" position to raise the rake. The finishing brush is raised at the same time.
13. Leave the bunker.
14. If tire tracks remain, use the broom to remove them.

Transporting

Transporting Procedure

When loading the machine into a trailer or a truck to transport it, drive the machine in reverse. When unloading, drive the machine forward.

Cleaning after Use

The purpose of the machine cleaning is to:

- Prevent accidents
- Prevent damage to the machine
- Maintain machine performance

Properly clean the machine to maintain its functionality and performance.

If you detect any abnormalities with the machine, immediately perform maintenance or repairs.

Engine

Cleaning of Engine-Associated Parts

Caution

Perform operations after the muffler, engine and other parts have sufficiently cooled. Otherwise, you may get burned.

1. Clean clippings and remove dirt.
2. Blow compressed air to clean any grass or flammable materials that may be attached on or around the muffler.

Main Vehicle

Cleaning of Oil Cooler

Important

An unclean oil cooler may cause malfunction of the hydraulic system.

Important

Do not use solid objects, such as a spatula or screwdriver, or high-pressure water to clean the radiator or oil cooler.

Otherwise, special fins or tubes may be damaged, possibly resulting in reduced cooling performance or hydraulic oil leakage.

If the oil cooler has been contaminated with dust, be sure to clean it.

After operating the machine in a dusty environment, it is important to remove dust as soon as possible.

1. Open the rear cover.
2. Carefully clean the front and back of the oil cooler with water or compressed air.

Storage

Short-Term Storage

Short-term storage means that the machine is temporarily stored (within 1 month) without use.

Follow the instructions below for short-term storage of the machine.

1. Cleaning
 - Remove dirt, grass clippings, oil stains etc. completely from the main vehicle and engine.
2. Storage location
 - Cover the machine and store it in a dry place where it will not be exposed to rain.

Precautions for Maintenance	Page 6-2
Jacking Up The Machine	Page 6-2
About Jacking Up The Machine	Page 6-2
Jack-Up Points	Page 6-2
Inspection and Cleaning	Page 6-3
Engine	Page 6-3
Main Vehicle	Page 6-5
Supplying Fluids	Page 6-6
Engine	Page 6-6
Main Vehicle	Page 6-7
Greasing	Page 6-8
About Greasing	Page 6-8
Greasing Points	Page 6-9
Lubrication	Page 6-11
About Lubrication	Page 6-11
Lubricating Points	Page 6-11
Adjustment	Page 6-12
Adjustment of Speed Adjustment Plate	Page 6-12
Adjustment of Rake	Page 6-12
Adjustment of Blade	Page 6-13
Adjustment of Finishing Brush	Page 6-13
Adjustment of Belt Tension	Page 6-14
Replacement	Page 6-15
Engine	Page 6-15
Main Vehicle	Page 6-17
Storage	Page 6-24
Long-Term Storage	Page 6-24

Maintenance

Precautions for Maintenance

Warning

The chapter "Maintenance" in this manual describes practical measures which should be performed by a mechanic with expertise. The owner should instruct the mechanic with expertise to perform maintenance service for this machine.

Caution

First, learn well the operations you plan to perform.

Important

Use tools appropriate for each operation.

Important

Use Baronsess genuine parts for replacement and accessories. Our product warranty may be void if you use non-genuine parts for replacement or accessories.

Jacking Up The Machine

About Jacking Up The Machine

Warning

When replacing a tire or beginning any other maintenance or repairs, be sure to chock the wheels to prevent the machine from moving. Before jacking up the machine, park it on a hard, flat surface such as a concrete floor and remove any obstacles that could prevent you from performing the work safely. When necessary, use an appropriate chain block, hoist, or jack. Support the machine securely with jack stands or appropriate blocks. Failure to do so may cause the machine to move or fall, resulting in injury or death.

Important

Only place a jack under the jack-up points specified. Placing a jack at any other point will result in damage to the frame or other parts.

Use the jack-up points identified in this manual when jacking up the machine.

Jack-Up Points

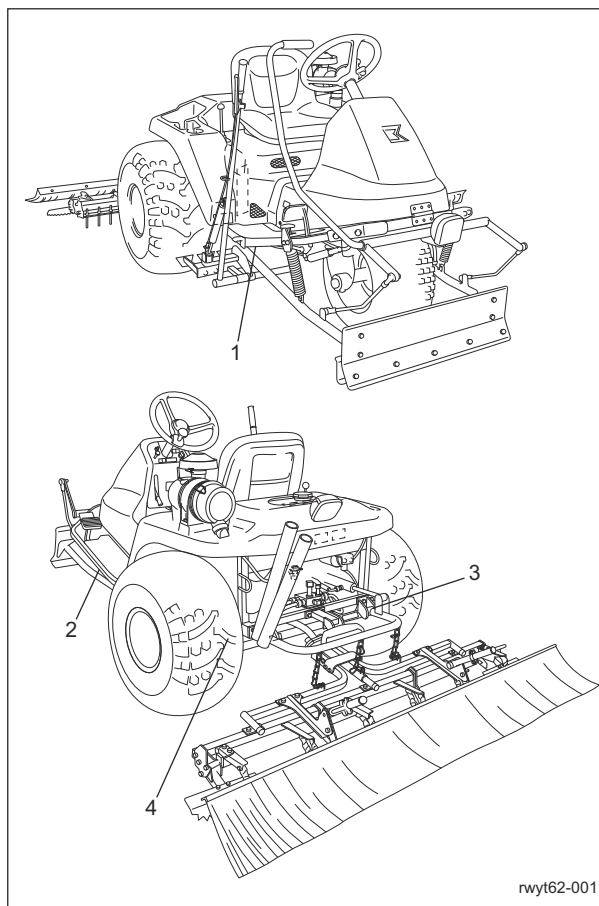

rwy62-001

Jack-Up Points_001

	Jack-up Points
1	Front right frame
2	Front left frame
3	Rear right frame
4	Rear left frame

1. Front right frame

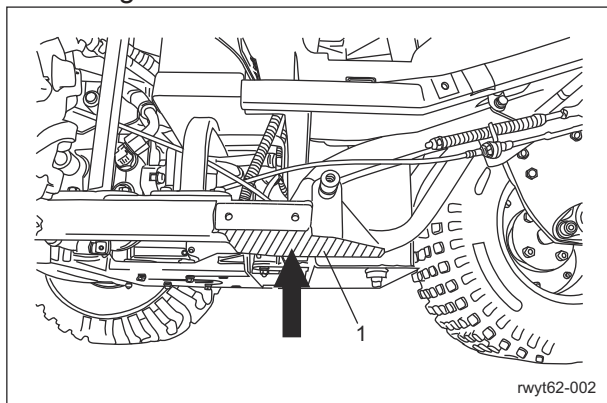

Jack-Up Points_002

1	Reinforcing plate
---	-------------------

2. Front left frame

Important

One nut is used to install the reinforcing plate. Be careful that the jack does not hit the nut.

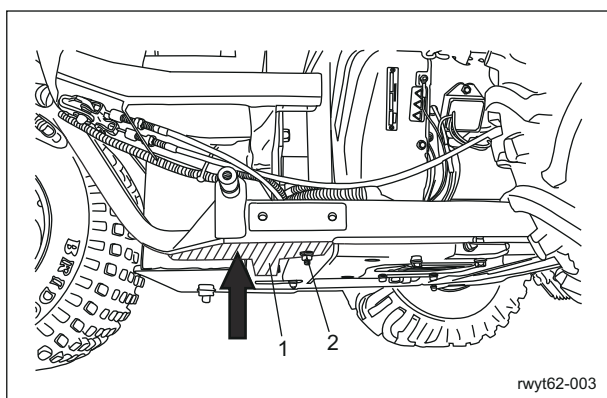

Jack-Up Points_003

1	Reinforcing plate
2	Nut

3. Rear right frame

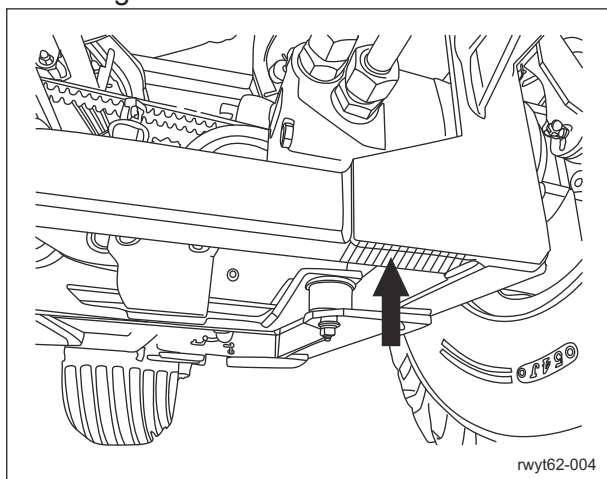

Jack-Up Points_004

4. Rear left frame

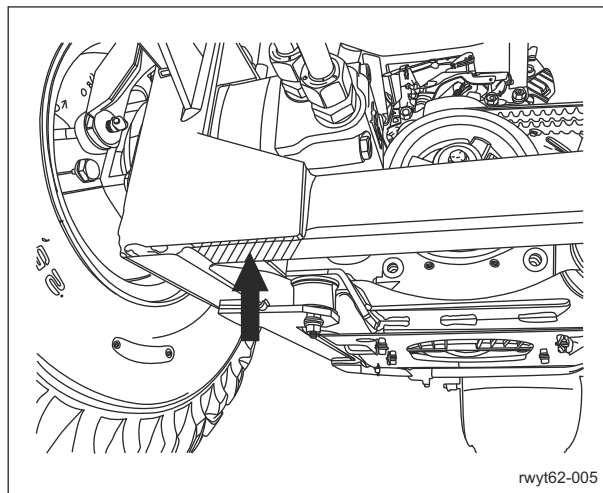

Jack-Up Points_005

Inspection and Cleaning

Inspect and clean the machine with the goals of the followings.

- Accident prevention
- Failure prevention
- Performance retention

Make efforts for early detection of the machine failure and prevention of the sudden occurrence of trouble.

Perform maintenance and repair works immediately if any abnormality is found in the machine.

Engine

Cleaning of Air Cleaner Element

Important

When cleaning the air cleaner element, do not use a petroleum solvent.
When cleaning and drying the air cleaner element, do not use compressed air.

Important

The inner element cannot be cleaned.

1. Follow the steps below to clean the outer element.

- [1] Remove the clip, remove the cover, and then remove the outer element.

Maintenance

- [2] While paying close attention not to damage the outer element, tap a solid portion of the outer element to remove dust and dirt.
If the outer element is extremely contaminated, replace it with a new one.
- [3] Attach the outer element to the air cleaner body.
- [4] Install the cover, and then affix it securely with the clip.

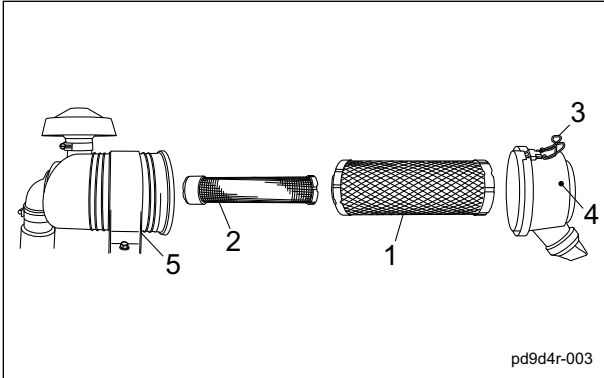

Cleaning of Air Cleaner Element_001

1	Outer element
2	Inner element
3	Clip
4	Cover
5	Air cleaner body

Cleaning of Fuel Strainer

Important

Shut off the fuel valve, and then clean the fuel strainer in a clean location, free of dust and dirt.

1. Remove the filter pot, wash the filter and inside of the filter pot using a solvent, such as a hardly flammable kerosene, and then blow compressed air to dry them.

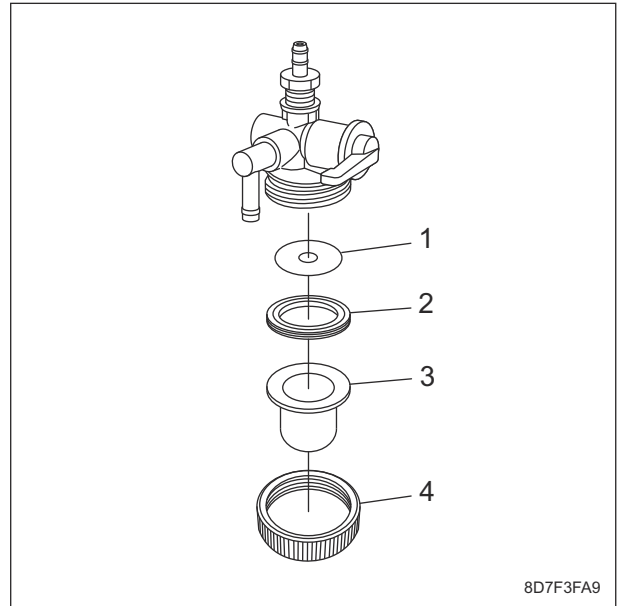

Cleaning of Fuel Strainer_001

1	Filter
2	Packing
3	Filter pot
4	Ring

2. Make sure that there is no fuel leakage after it is installed.

Main Vehicle

Inspection of Hydraulic Hoses and Pipes

 **Warning**

When checking the hydraulic circuit for pinhole leaks or oil leakage from nozzles, do not use your hands. Use items such as paper or corrugated cardboard to find leakage points.

Be extremely careful with high-pressure oil as it may pierce your skin, resulting in personal accidents.

If fluid is injected into the skin it must be surgically removed within a few hours by a doctor familiar with this form of injury or gangrene may result.

1. Make sure that there is no wear, deterioration or damage in the hydraulic hoses and pipes.
2. Make sure that there is no looseness in the connecting portion of the hydraulic hoses and pipes.
3. Check underneath the machine for hydraulic oil leakage.

Inspection of Belt

 **Caution**

The engine must be stopped when the belt is inspected.

Be careful since the belt may rotate and something may get caught in it, even if the engine is stopped.

 **Caution**

The engine muffler is near the belt. Inspect the belt after the muffler has sufficiently cooled.

1. Press the middle of the belt with your finger to check the belt tension.
2. Make sure that there are no cracks, damage or abnormal wear.

Inspection of Electrical Wiring

Important

Electrical short circuit will cause fire, electrical leakage and malfunction of electrical equipments.

1. Make sure that there is no defacement in wires and terminals.
2. Make sure that there is no deterioration or damage in wires and terminals.
3. Make sure that there is no looseness in wiring connections.
4. Make sure that there is no poor terminal connection.

Inspection of Wheel Mounting Bolt

Important

Tighten the wheel mounting bolts on the specified torque by using a torque wrench.

1. Check the wheel mounting bolts and wheel nuts for looseness and coming off.
2. Check the wheel mounting bolts and wheel nuts for cracks and damages.
3. Check the wheel mounting bolts and wheel nuts for rust.
4. Check around the wheel mounting bolts and wheel nuts for traces of rust fluid.
5. Check the wheel mounting bolts for unequal bolt length.
6. Check the wheel mounting bolts and wheel nuts for stripped threads and abrasion.

Maintenance

Supplying Fluids

Engine

Supply of Engine Oil

Important

Do not fill too much engine oil. Otherwise, the engine may be damaged.

Important

Do not mix different types of engine oil.

Important

Be sure to use engine oil that is classified as API Service Grade SF or higher, with an SAE Viscosity that is appropriate for the operating environment (ambient temperature).

Important

Securely install the oil level gauge and oil filler cap. If they are insufficiently tightened or there is an insufficient seal, negative pressure inside the crankcase cannot be maintained, causing the oil to rise, possibly resulting in the production of white smoke and damage to the engine.

If the engine oil level is lower than the lower limit line on the oil level gauge, supply engine oil.

Supply engine oil through the oil filler port.

1. Place the machine so that the engine is level.
2. Stop the engine.
3. Open the rear cover.
4. Remove the oil filler cap.

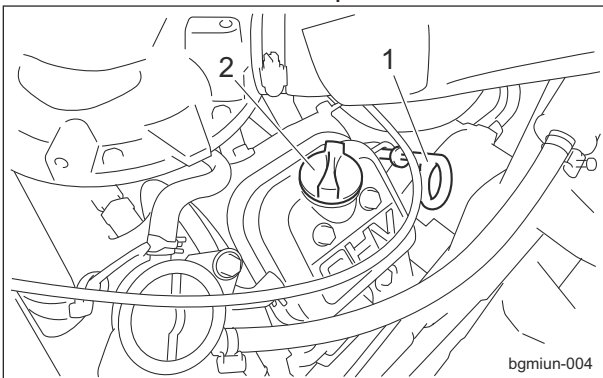

Supply of Engine Oil_001

1	Oil level gauge
2	Oil filler cap

5. Supply new engine oil through the oil filler port.
Supply oil until it reaches a level in between the upper and lower limit lines on the oil level gauge.
6. Install the oil filler cap.
7. It will take a while for the supplied engine oil to descend into the oil pan.
Check the oil level again 10 to 20 minutes after supplying the oil.
If the engine oil level is low, supply oil until it reaches the specified level.
8. Close the rear cover.

Main Vehicle

Supply of Hydraulic Oil

Important

Do not mix different types of oil.

Important

For the hydraulic oil to be used, consult Characteristics of Hydraulic Oil and use the oil whose characteristics are equivalent or superior to those specified there. Especially regarding kinematic viscosity and viscosity index, use of hydraulic oil whose figures are less than those of the specified hydraulic oil will cause a malfunction in the hydraulic circuit.

Important

Supply hydraulic oil after checking the oil in the hydraulic tank has been sufficiently cooled down. Oil level changes depending on the hydraulic oil temperature.

Characteristics of Hydraulic Oil

ISO Viscosity Grade		ISO VG32
Density	15 °C (59 °F)	0.869 g/cm ³ (0.0313 lb/in ³)
API Gravity		31.3
Flash Point (Open Cup)		202 °C (396 °F)
Pour Point		-40 °C (-40 °F)
Kinematic Viscosity	40 °C (104 °F)	32 mm ² /s (32 cSt)
	100 °C (212 °F)	6.1 mm ² /s (6.1 cSt)
Viscosity Index		141

Note:

In Japan, "Shell Tellus S2V32" meets the characteristics described above.

However, in other countries, the specification of Shell Tellus S2V32 can be below what is required.

Please check the product data sheet to ensure that it meets the requirements before using.

1. Remove the dimple knobs, and then open the front cover.

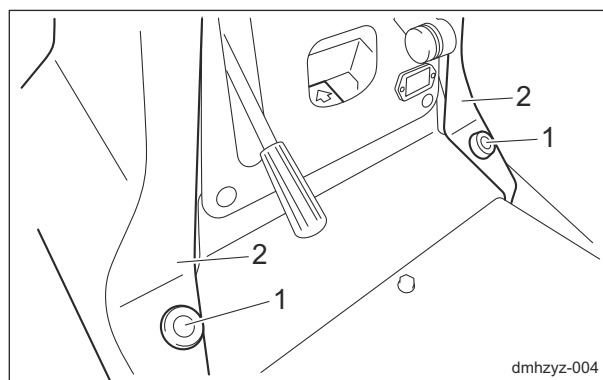

Supply of Hydraulic Oil_001

1	Dimple knobs
2	Front cover

2. Remove the bolts, and then remove the cover.

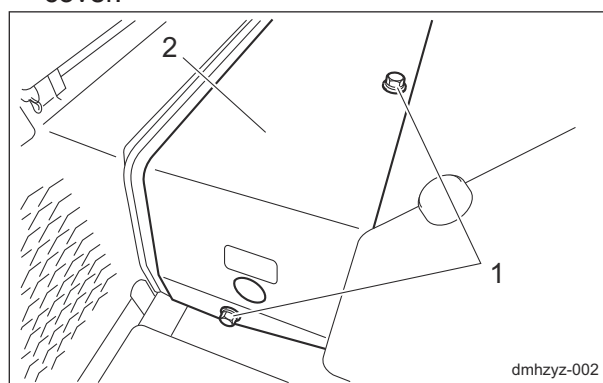

Supply of Hydraulic Oil_002

1	Bolt
2	Cover

3. If the oil level is low, open the tank cap and supply oil.

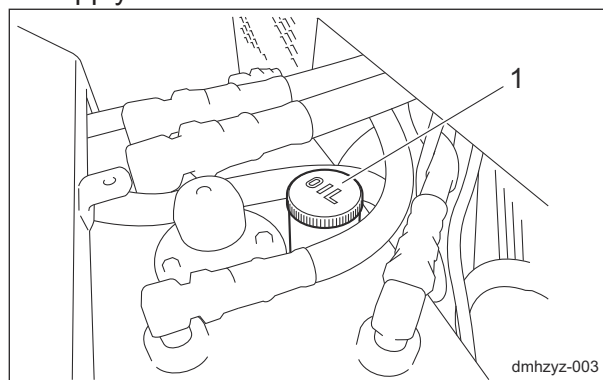

Supply of Hydraulic Oil_003

1	Tank cap
---	----------

4. Start the engine, and then repeat the steps below a few times.

- Raise and lower the rake.
- Move forward and reverse with the rake raised.

Maintenance

5. Lower the rake and maintain that position on a level surface, and then check to see if the oil level is at the middle of the oil gauge. If necessary, supply oil.
6. Check underneath the machine for oil leakage.
7. Install the cover.
8. Close the front cover.

Supply of Battery Fluid

Danger

If battery fluid comes into contact with eyes, it may result in blindness. Immediately flush with plenty of water and take medical care from an ophthalmologist.

Danger

Do not drink battery fluid. If battery fluid enters the mouth or is swallowed, it may result in burns inside the mouth. Immediately and repeatedly gargle with plenty of water, then drink plenty of water, and take medical care.

Danger

When you supply battery fluid, wear protective garments and safety glasses, etc.

Warning

If battery fluid adheres to the skin or clothing, it may cause burns or damage clothing. Immediately flush with plenty of water, then wash thoroughly with soap.

Warning

Do not allow the battery fluid level to become lower than the LOWER LEVEL (minimum fluid level line). The battery may explode if it is used or charged while the battery fluid level is at the LOWER LEVEL (minimum fluid level line).

Warning

When refilling, do not fill purified water above the UPPER LEVEL (maximum fluid level line). Doing so may result in electrolyte leaks.

Caution

Implement after the engine and muffler etc. have well cooled down. Otherwise, you may get burned.

Important

If battery fluid adheres to the vehicle, it may cause corrosion. Wipe it off with a cloth dampened with water, and then flush with water.

If the battery fluid level is lower than halfway between the UPPER LEVEL (maximum fluid level line) and LOWER LEVEL (minimum fluid level line), add purified water.

1. Loosen the vent plug and remove it.
2. Add purified water up to the UPPER LEVEL (maximum fluid level line)
3. Tighten the vent plug securely.

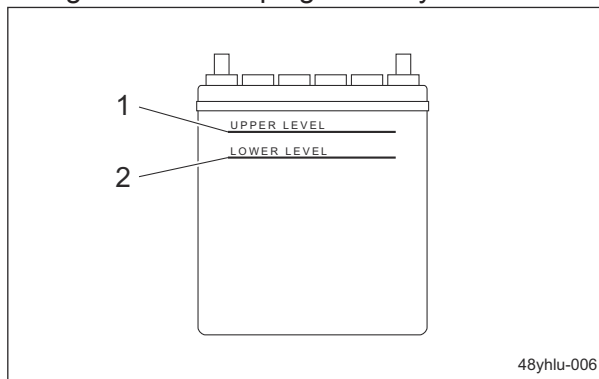

48yflu-006

Supply of Battery Fluid_001

1	Maximum fluid level line
2	Minimum fluid level line

Greasing

About Greasing

Since there may be adhesion or damage due to lack of grease on moving parts, they must be greased.

Add urea-based No. 2 grease in accordance with the Maintenance Schedule.

Other locations where the specified grease or lubricant is used are indicated in "Greasing Points".

Add grease using the specified grease or lubricant.

Greasing Points

Grease nipples are installed in the following locations. Add grease every 50 hours of operation.

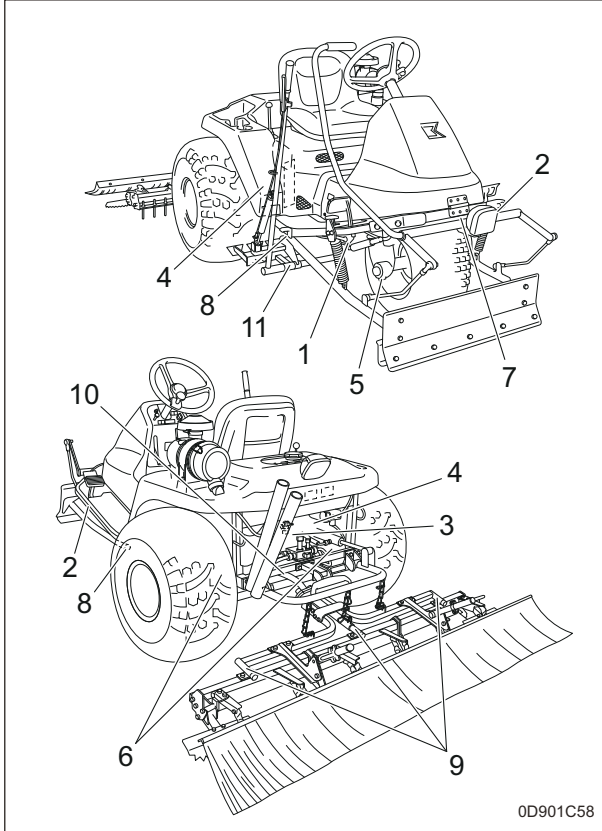

Greasing Points_001

Location	No. of Greasing Points	
	2WD	3WD
1 Traveling pedal fulcrum	1	1
2 Brake pedal fulcrum	1	1
3 Belt tension lever	1	1
4 Pump neutral lever fulcrum	1	1
5 Front wheel shaft rhombic flange unit	2	1
6 Rear wheel brake lever fulcrum	2	2
7 Blade lever fulcrum	1	1
8 Blade arm fulcrum	2	2
9 Rake mount	3	3
10 Rake fulcrum	1	1
11 Cultivator arm fulcrum	2	2

1. Traveling pedal fulcrum

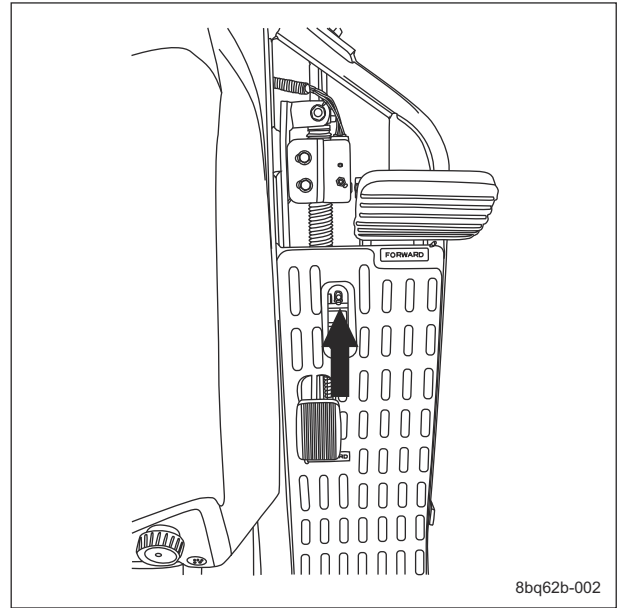

Greasing Points_002

2. Brake pedal fulcrum

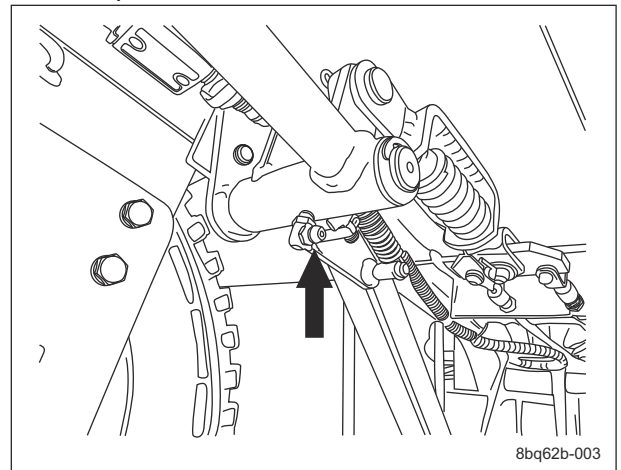

Greasing Points_003

3. Belt tension lever (below pump pulley)

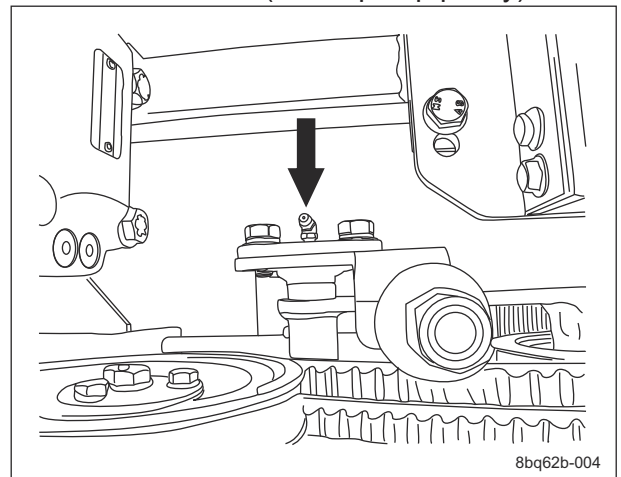

Greasing Points_004

Maintenance

4. Pump neutral lever fulcrum (above piston pump)

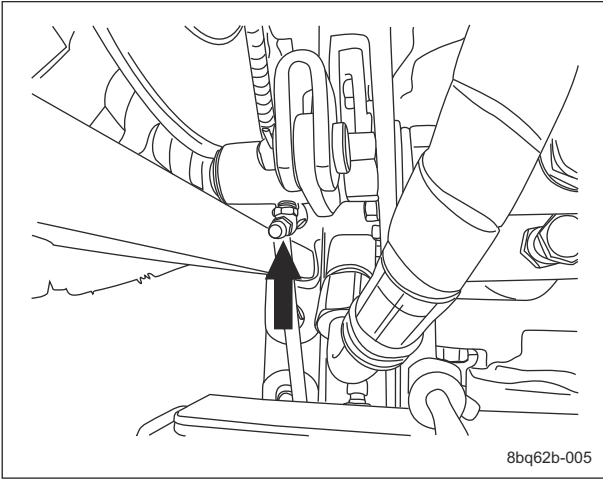

Greasing Points_005

5. Front wheel shaft rhombic flange unit

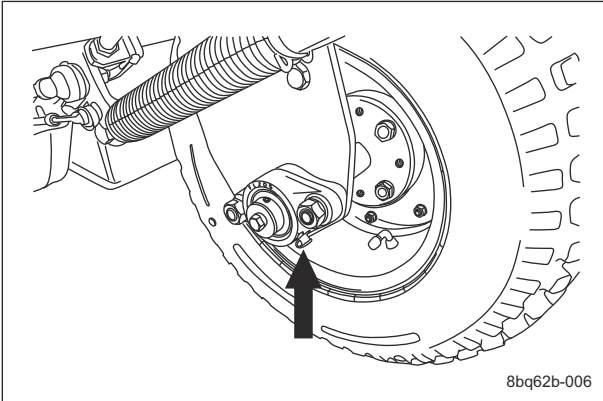

Greasing Points_006

6. Rear wheel brake lever fulcrum

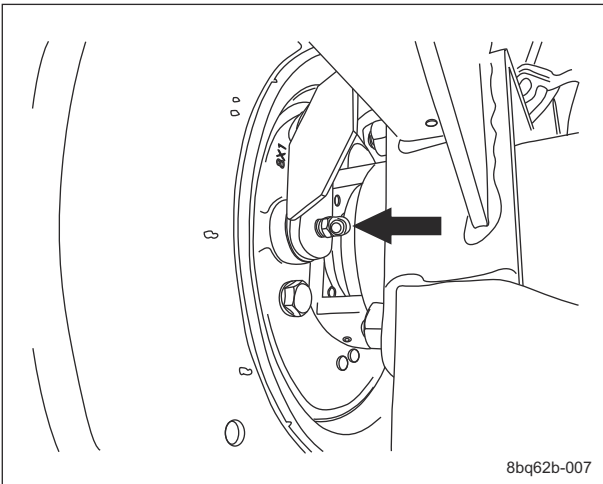

Greasing Points_007

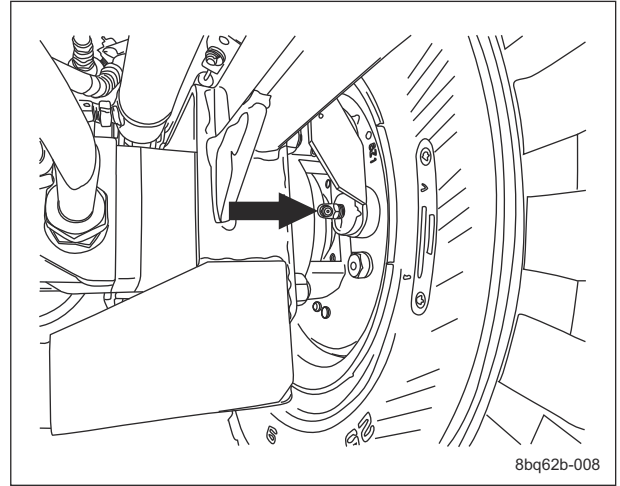

Greasing Points_008

7. Blade lever fulcrum

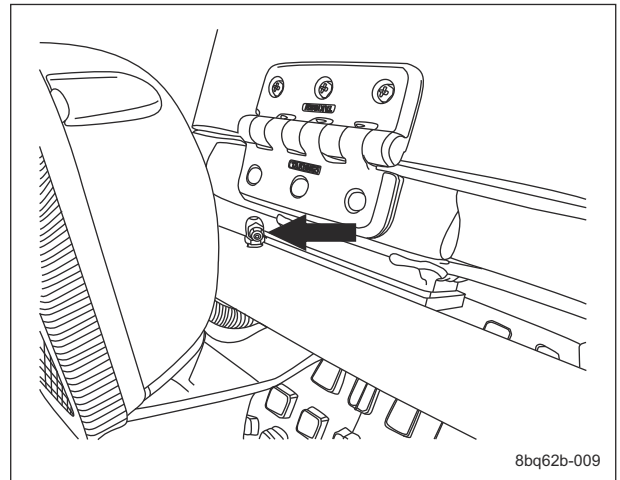

Greasing Points_009

8. Blade arm fulcrum

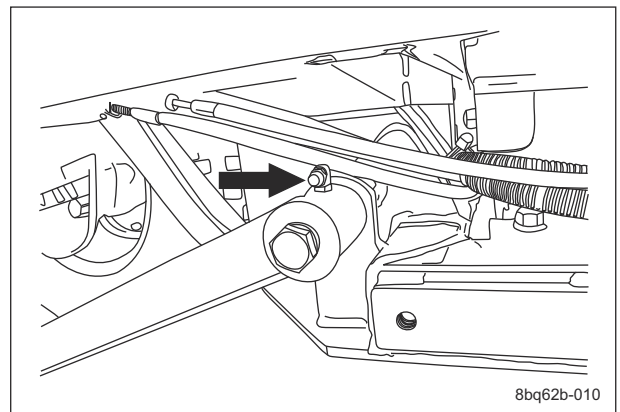

Greasing Points_010

9. Rake mount

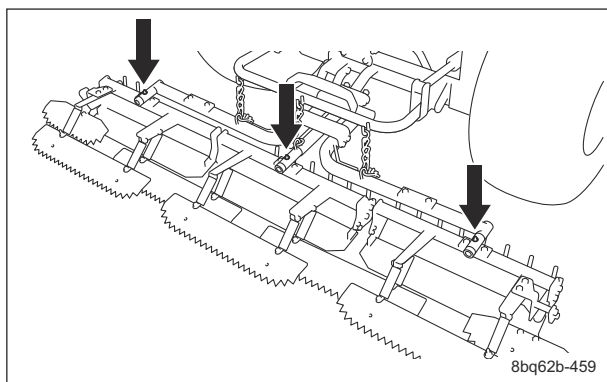

Greasing Points_011

10. Rake fulcrum

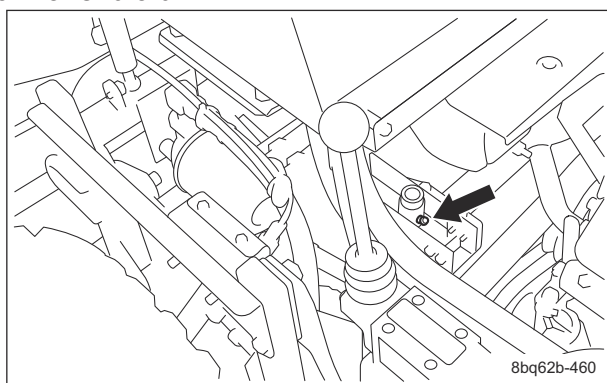

Greasing Points_012

11. Cultivator arm fulcrum

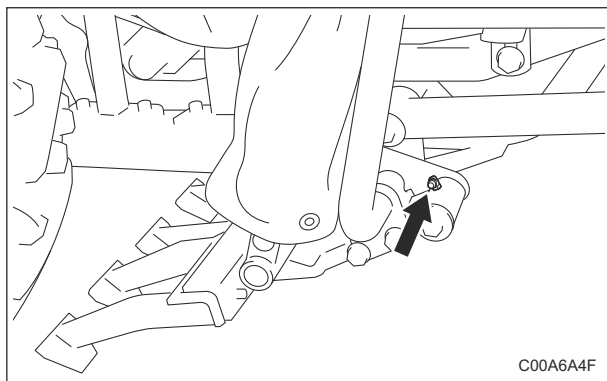

Greasing Points_013

Lubricating Points

Apply lubricant at the following locations every 50 hours of operation.

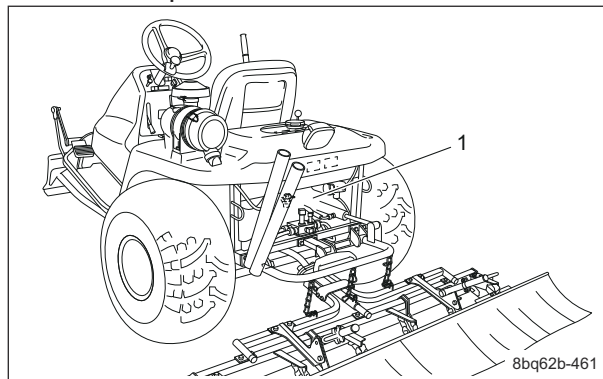

Lubricating Points_001

	Location	No. of lubricating points
1	Rake up/down cylinder spherical bearing	1

1. Rake up/down cylinder spherical bearing
There is one point.

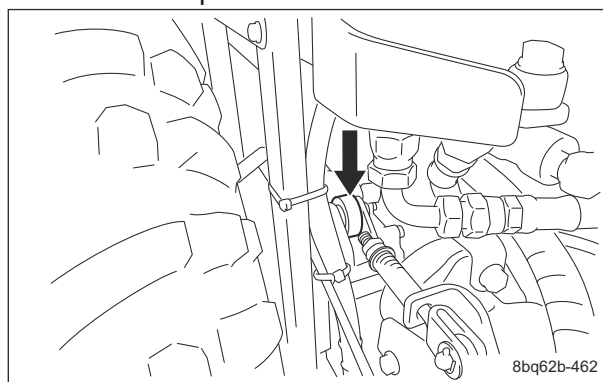

Lubricating Points_002

Lubrication

About Lubrication

It is necessary to lubricate moving parts so that they will not become stuck or damaged. The locations where lubricant is used are indicated in "Lubricating Points". Apply the lubricant.

Maintenance

Adjustment

Adjustment of Speed Adjustment Plate

Warning

Since it is dangerous, do not adjust the speed adjustment plate while traveling.

The height of the speed adjustment plate can be adjusted with the bolts. Use the speed adjustment plate to operate the machine at a constant speed.

1. Loosen the bolts.
2. Determine the operating speed, adjust the height of the speed adjustment plate, and then tighten the bolts.

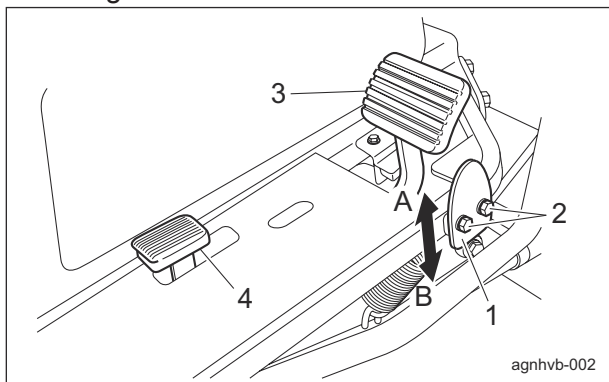

Adjustment of Speed Adjustment Plate_001

1	Speed adjustment plate
2	Bolt
3	Forward pedal
4	Reverse pedal
A	Slow
B	Fast

Adjustment of Rake

Caution

Before adjusting the rake, be sure to stop the engine.

1. The rake can be adjusted with the nut.
 - [1] On a level surface, lower the rake, and then drive the machine forward about approximately 200 mm (7.87 in).
 - [2] Place a wooden board with a thickness of about 15 mm (0.59 in) under the warp board.

- [3] Adjust the fork prong bar to a position where the rake load is applied to the wooden board and the tip of the fork prong bar lightly touches the ground, and then lock it in place with the nut.

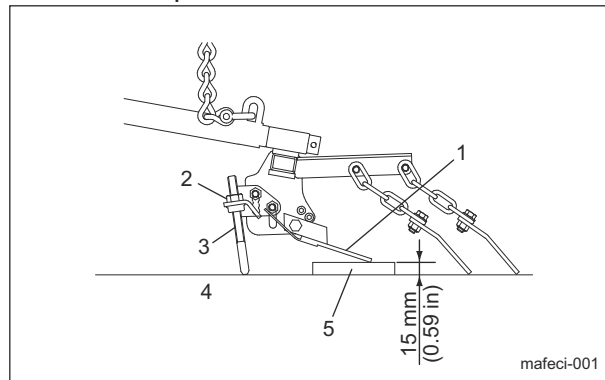

Adjustment of Rake_001

1	Warp board
2	Nut
3	Fork prong bar
4	Flat concrete surface
5	Wooden board, etc.

2. When adjusting the links of the cross-link chains, adjust the rake stopper.
 - As a standard, 7 links of the chain are used.
 - [1] Loosen the nut.
 - [2] Raise the rake.
 - [3] Adjust the rake stopper so that it lightly touches the rake, and then tighten the nut.
 - [4] Raise and lower the rake to check that it lightly touches the rake stopper.

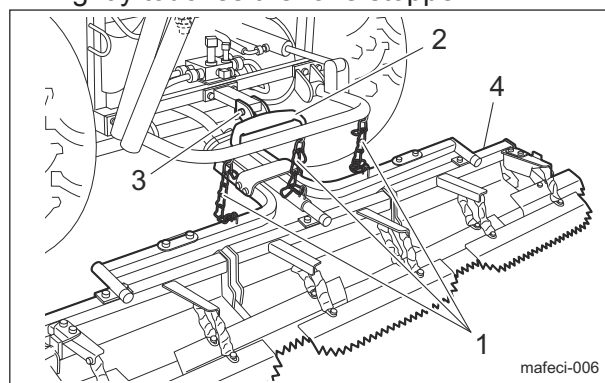

Adjustment of Rake_002

1	Cross-link chains
2	Rake stopper
3	Nut
4	Rake

Adjustment of Blade

Note:

Depending on the specifications, this function may not be available.

The blade can be adjusted with the bolt.

1. Loosen the bolt, and then move the small blade to the desired position.

[1] Toward A to take a thin layer from the surface of the sand

[2] Toward B to take a thick layer from the surface of the sand

2. Tighten the bolt.

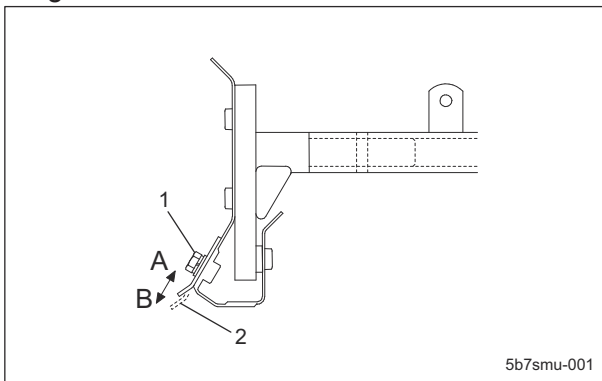

Adjustment of Blade_001

1	Bolt
2	Small blade

Adjustment of Finishing Brush

Note:

Depending on the specifications, this function may not be available.

The height of the finishing brush can be adjusted by moving the left and right movable arms while gripping the left and right clutch levers.

Return the clutch levers after adjusting the height of the brush on the ground according to the bunker conditions.

The mounting height can be adjusted to one of four levels.

1. When traveling, adjust to the lowest position.

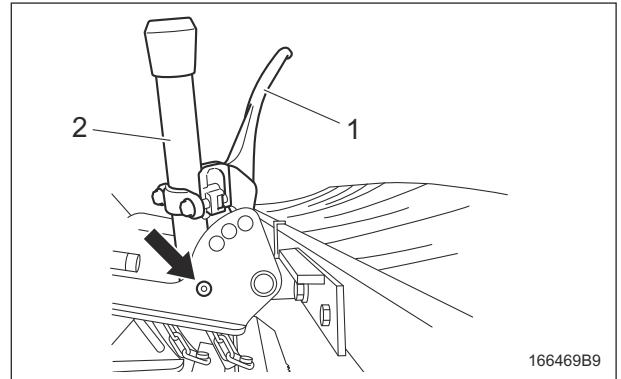

Adjustment of Finishing Brush_001

1	Clutch lever
2	Movable arm

2. When used for light finishing, adjust to the position second from the bottom.

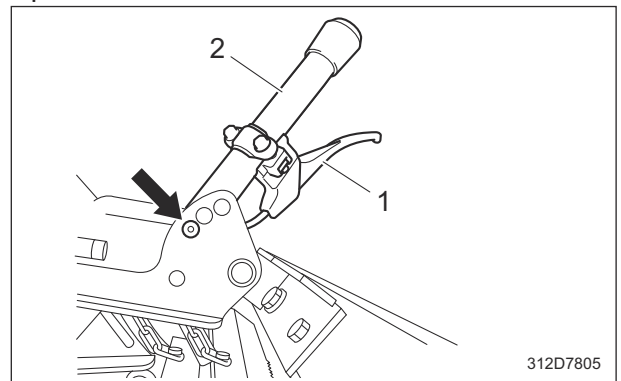

Adjustment of Finishing Brush_002

1	Clutch lever
2	Movable arm

3. When used for normal finishing, adjust to the position third from the bottom.

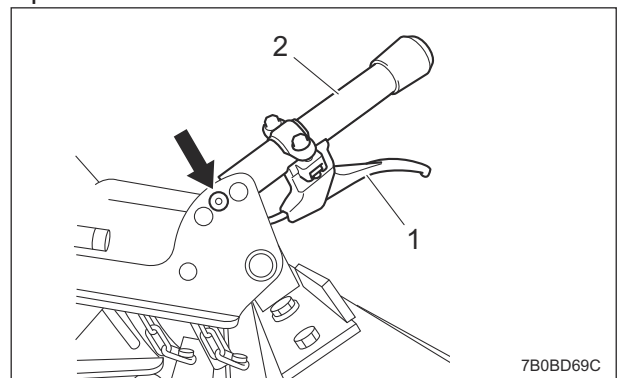

Adjustment of Finishing Brush_003

1	Clutch lever
2	Movable arm

Maintenance

4. When used for heavy finishing, adjust to the highest position.

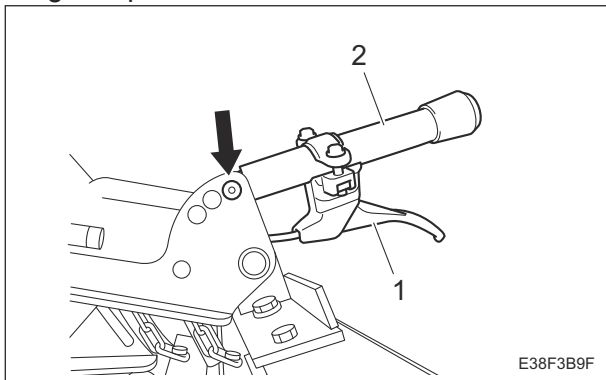

Adjustment of Finishing Brush_004

1	Clutch lever
2	Movable arm

Adjustment of Belt Tension

Warning

Be sure to stop the engine before adjusting the belts.

Caution

Implement after the engine and muffler etc. have well cooled down. Otherwise, you may get burned.

Important

For the specified value of belt tension, refer to Adjusted Values. Before making sure of belt tension, rotate the belt several times.

Adjustment of Pump Drive Belt

1. Move the machine to a level ground.
2. Apply the parking brake.
3. Lower the rake.
4. Stop the engine.
5. Open the rear cover.
6. Check the belt tension.

The criterion for the belt tension is that the belt slacks approximately 10 mm (0.39 in) when you apply a force of 98 N (10 kgf) with your finger to the belt at the middle point between the pulleys (arrow in the diagram).

7. If the belt tension is not at the approximate value, follow the steps below to adjust it.

[1] Loosen the nut.

[2] Adjust the belt tension with high nut.

- Tighten the high nut to increase the belt tension.
- Loosen the nut to reduce the belt tension.

[3] Tighten the high nut until there is no clearance between the spring cover and the tension fulcrum fitting.

[4] Lock it with the nut.

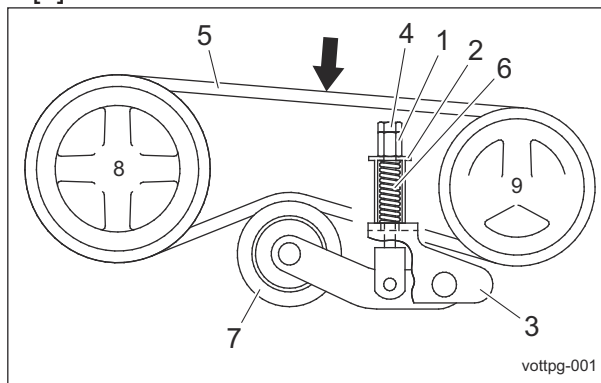

Adjustment of Pump Drive Belt_001

1	High nut
2	Spring cover
3	Tension fulcrum fitting
4	Nut
5	Belt
6	Spring
7	Tension pulley
8	Engine pulley
9	Pump pulley

8. After adjustment of the belt tension, check the belt tension again.

If the belt tension is still not at the approximate value after repeating the adjustment several times, replace the belt with a new one.

9. Close the rear cover.

Replacement

Engine

Replacement of Engine Oil

Caution

Be careful with hot oil, which could cause burns if it contacts your skin.

Important

When you change the engine oil, be sure to drain it into a bowl and discard it in accordance with local laws and regulations.

Important

Be sure to use engine oil that is classified as API Service Grade SF or higher, with an SAE Viscosity that is appropriate for the operating environment (ambient temperature).

Important

Securely install the oil level gauge and oil filler cap.

Change the engine oil more frequently if the engine oil is contaminated and, especially, if you use the machine in dusty areas or operate the engine at high loads or in high temperatures.

1. Follow the steps below to remove the old engine oil.
 - [1] Start and run the engine to warm up the engine oil.
 - [2] Stop the engine on a level surface.
 - [3] Remove the drain plug while the engine oil is warm, and then drain the oil into a bowl.
 - [4] Wind new sealing tape around the drain plug, and then replace it in the engine.

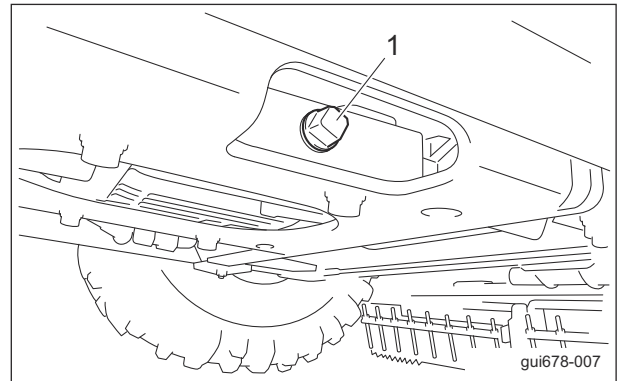

Replacement of Engine Oil_001

1	Drain plug
---	------------

2. Open the rear cover.
3. Remove the oil filler cap, and then supply new engine oil until the oil reaches a level in between the upper and lower limit lines on the oil level gauge.
The engine oil quantity is 1.0 dm³ (1.0 L).
4. Remove the oil level gauge, and then insert it all the way to check the oil level.
5. After checking the oil level with the oil level gauge, add more engine oil if it is insufficient.
The engine oil quantity (including the oil filter) is approximately 1.6 dm³ (1.6 L).
6. Install the oil filler cap.

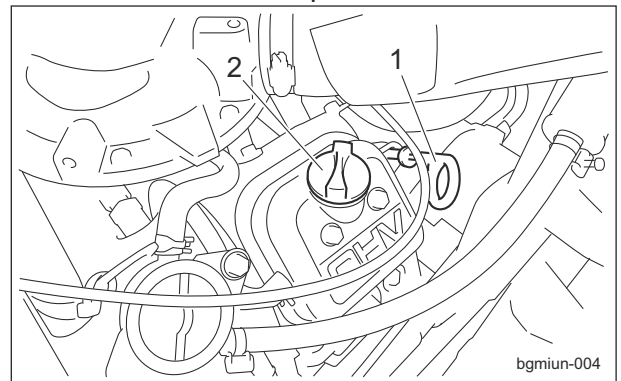

Replacement of Engine Oil_002

1	Oil level gauge
2	Oil filler cap

7. It will take a while for the supplied engine oil to descend into the oil pan.
Check the oil level again 10 to 20 minutes after supplying the oil.
8. Close the rear cover.
9. Check underneath the machine for oil leakage.

Maintenance

Replacement of Engine Oil Filter

Caution

Be careful with hot oil, which could cause burns if it contacts your skin.

Important

When replacing the engine oil filter, be sure to drain the engine oil into a container and discard it in accordance with local laws and regulations.

Important

Be sure to use engine oil that is classified as API Service Grade SF or higher, with an SAE Viscosity that is appropriate for the operating environment (ambient temperature).

Important

Securely install the oil level gauge and oil filler cap.

1. With the filter wrench, remove the old filter cartridge.

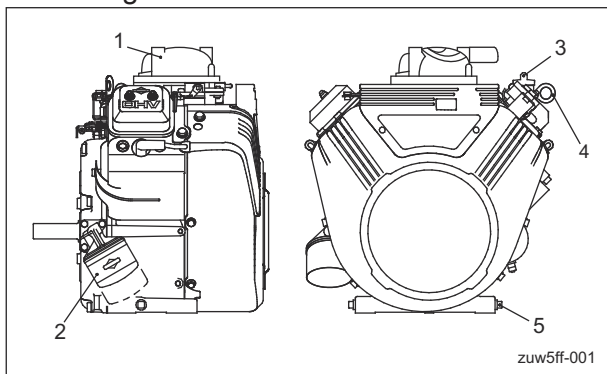

Replacement of Engine Oil Filter_001

1	Engine
2	Filter cartridge
3	Oil filler cap
4	Oil level gauge
5	Drain plug

2. Lightly coat the packing of the new filter cartridge with engine oil.
3. Hand-tighten the filter cartridge until the packing contacts the sealing surface, and then hand-tighten additional 1/2 to 3/4 turn from that point (without using a filter wrench).

4. Supply engine oil until it reaches the specified level.
"Supply of Engine Oil" (Page 6-6)
5. Start the engine, and then stop it after 10 to 20 minutes.
6. Make sure that there is no oil leakage at the sealing surface of the filter cartridge.
7. Check the engine oil level.
If it is low, supply engine oil until it reaches the specified level.

Replacement of Air Cleaner Element

Important

A contaminated air cleaner element may cause malfunction of the engine.

1. The timing for replacing the air cleaner element is described below.
 - [1] Replace the air cleaner element in accordance with the Maintenance Schedule.
 - [2] If it is significantly contaminated, replace it, even if the hours of operation do not exceed the specified time.
2. Replace the air cleaner element by following the same steps as for cleaning the air cleaner element.
"Cleaning of Air Cleaner Element" (Page 6-3)

Replacement of Fuel Filter

Important

While installing the fuel filter, prevent contamination with dirt or dust. The fuel contaminated with dirt or dust will cause engine failure.

Important

Since the fuel filter is a cartridge, it cannot be disassembled or cleaned.

1. Remove the old fuel filter.
2. Install a new fuel filter with the arrow marked on it pointing toward the engine.

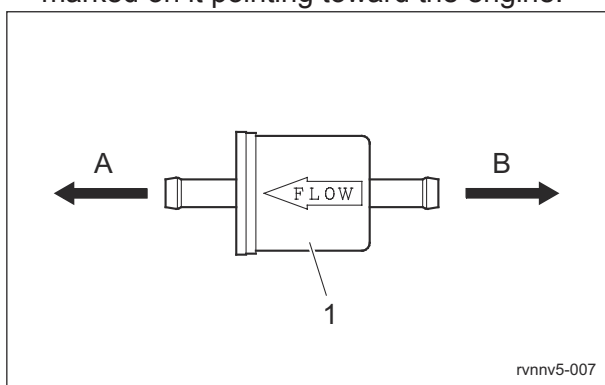

Replacement of Fuel Filter_001

1	Fuel filter
A	Engine
B	Fuel cock

Main Vehicle

Replacement of Hydraulic Oil

Caution

Be careful with hot oil, which could cause burns if it contacts your skin.

Important

If the oil emulsifies or if it becomes even slightly less transparent, change the oil immediately.

Important

When you change the hydraulic oil, be sure to drain it into a bowl and discard it in accordance with local laws and regulations.

Important

For the hydraulic oil to be used, consult Characteristics of Hydraulic Oil and use the oil whose characteristics are equivalent or superior to those specified there. Especially regarding kinematic viscosity and viscosity index, use of hydraulic oil whose figures are less than those of the specified hydraulic oil will cause a malfunction in the hydraulic circuit.

Characteristics of Hydraulic Oil

ISO Viscosity Grade		ISO VG32
Density	15 °C (59 °F)	0.869 g/cm ³ (0.0313 lb/in ³)
API Gravity		31.3
Flash Point (Open Cup)		202 °C (396 °F)
Pour Point		-40 °C (-40 °F)
Kinematic Viscosity	40 °C (104 °F)	32 mm ² /s (32 cSt)
	100 °C (212 °F)	6.1 mm ² /s (6.1 cSt)
Viscosity Index		141

Note:

In Japan, "Shell Tellus S2V32" meets the characteristics described above.

However, in other countries, the specification of Shell Tellus S2V32 can be below what is required.

Please check the product data sheet to ensure that it meets the requirements before using.

1. Follow the steps below to remove the old oil.
 - [1] Start and run the engine to warm up the oil.
 - [2] On a level surface, lower the rake, and then stop the engine.
 - [3] Remove the drain plug of the hydraulic tank, and then drain the old oil into a container.
 - [4] Wind new sealing tape on the drain plug, and then attach it to the hydraulic tank.

Maintenance

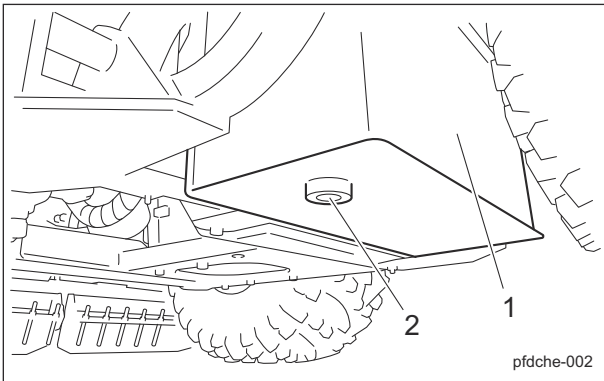

Replacement of Hydraulic Oil_001

1	Hydraulic tank
2	Drain plug

2. Open the tank cap, and then pour new oil from the fill port until the oil level reaches the middle of the oil gauge on the hydraulic tank.

The hydraulic tank capacity is approximately 15.0 dm³ (15.0 L).

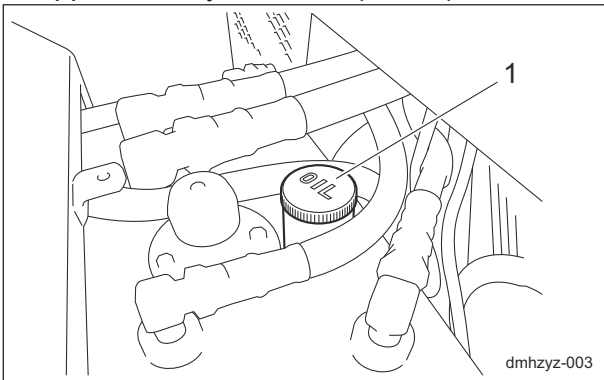

Replacement of Hydraulic Oil_002

1	Tank cap
---	----------

3. Tighten the tank cap securely.
4. Start the engine, and then repeat the steps below a few times.
 - Raise and lower the rake.
 - Move forward and reverse with the rake raised.
5. Lower the rake and maintain that position on a level surface, and then check to see if the oil level is at the middle of the oil gauge. If necessary, supply oil.
6. Check underneath the machine for oil leakage.

Replacement of Hydraulic Oil Filter

- Replacement of Hydraulic Oil Line Filter

⚠ Caution

Be careful with hot oil, which could cause burns if it contacts your skin.

Important

If the hydraulic oil emulsifies or if it becomes even slightly less transparent, change the oil immediately.

Important

When replacing the hydraulic oil filter, be sure to drain the oil into a container and discard it in accordance with local laws and regulations.

Important

Use hydraulic oil whose specification meets the requirements.

1. Remove the old filter cartridge.

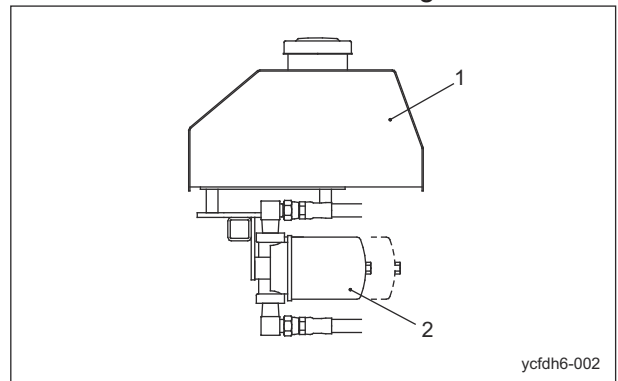

Replacement of Hydraulic Oil Line Filter_001

1	Fuel tank
2	Filter cartridge

2. Lightly coat the packing of the new filter cartridge with hydraulic oil, and then install the cartridge.
3. Screw in the filter by hand until the packing contacts the mounting surface. Then tighten additional 1/2 turn from that point.
4. Supply hydraulic oil until it reaches the specified level.
"Supply of Hydraulic Oil" (Page 6-7)

5. Start the engine, and then stop it after 10 to 20 minutes.
6. Make sure that there is no oil leakage at the sealing surface of the filter cartridge.
7. Check the hydraulic oil level.
If it is low, supply hydraulic oil until it reaches the specified level.

Replacement of Air Breather Element

⚠ Caution

Be careful with hot oil, which could cause burns if it contacts your skin.

1. Stop the engine on a flat surface.
2. Open the front cover.
3. Remove the bolt, then the cover.

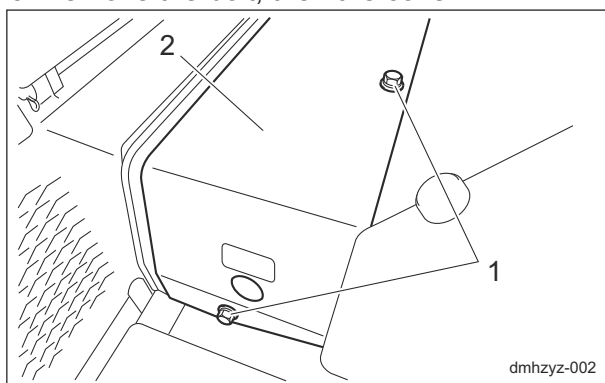

Replacement of Air Breather Element_001

1	Bolt
2	Cover

4. Loosen the air breather screw and remove the seal washer.

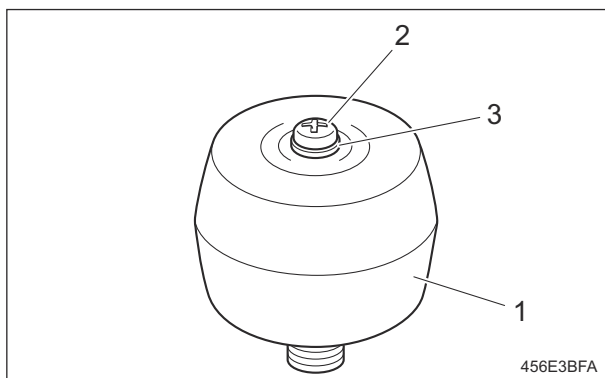

Replacement of Air Breather Element_002

1	Air breather
2	Screw
3	Seal washer

5. Remove the top cover of the air breather.

6. Remove the old element.

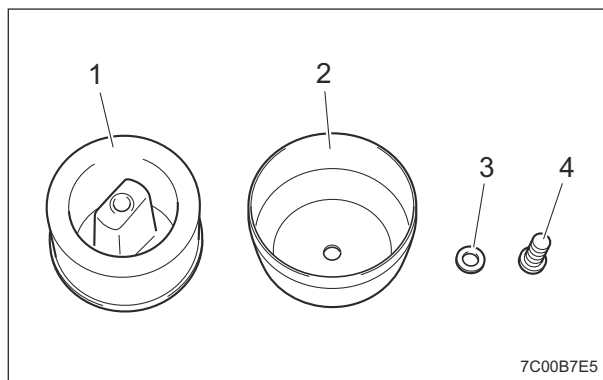

Replacement of Air Breather Element_003

1	Element
2	Top cover
3	Seal washer
4	Screw

7. Install the new element.

Important

If the seal washer is damaged, replace it with a new one.

8. Install the top cover of the air breather.
9. Install the seal washer and tighten the screw.
10. Install the cover and tighten the bolt.
11. Close the front cover.

Maintenance

Replacement of Belts

Warning

Be sure to stop the engine before replacing a belt.

Warning

If you have removed covers, etc., be sure to securely install them in their original positions. If covers, etc., remain removed, the operator or the mechanic may come in contact with rotating parts or belts, or foreign objects may fly off, possibly resulting in injuries.

Caution

Implement after the engine and muffler etc. have well cooled down. Otherwise, you may get burned.

■ Replacement of Pump Drive Belt

1. Move the machine to a level ground.
2. Apply the parking brake.
3. Lower the rake.
4. Stop the engine.
5. Open the rear cover.
6. Loosen the nut.
7. Loosen the high nut.
8. Remove the old belt.

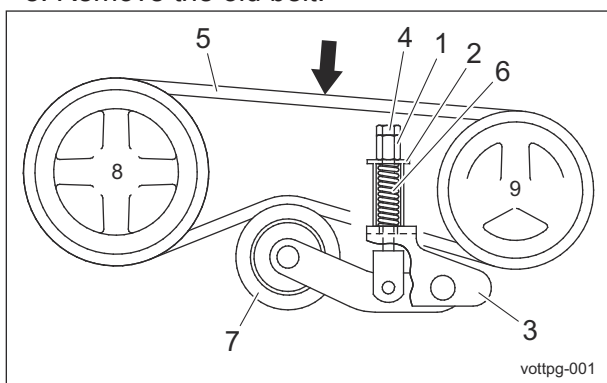

Replacement of Pump Drive Belt_001

1	High nut
2	Spring cover
3	Tension fulcrum fitting
4	Nut
5	Belt
6	Spring
7	Tension pulley
8	Engine pulley
9	Pump pulley

9. Install the new belt.
10. Check the belt tension.
The criterion for the belt tension is that the belt slacks approximately 10 mm (0.39 in) when you apply a force of 98 N (10 kgf) with your finger to the belt at the middle point between the pulleys (arrow in the diagram).
11. Close the rear cover.

Replacement of Tires

■ Replacement of Front Tire

1. Removing a front tire
Follow the steps below to remove the front tire:
[1] Securely place the jack beneath the jack-up points of the front left/right frame area, and then raise it until the tire lifts off the ground.
"Jack-Up Points" (Page 6-2)

Important

The installed parts differ according to 2WD and 3WD specifications.

- [2] Loosen the lock bolts (2 locations) for the right rhombic flange unit, and then remove bolt A.
- [3] Remove bolt B and nut B of the right rhombic flange unit, and then remove the right rhombic flange unit.
- [4] Remove bolt C, attaching the left and right front wheel bracket to the front wheel arm, and then lower the front wheel to the floor.

[5] Remove the wheel mounting bolt, and then remove the tire.

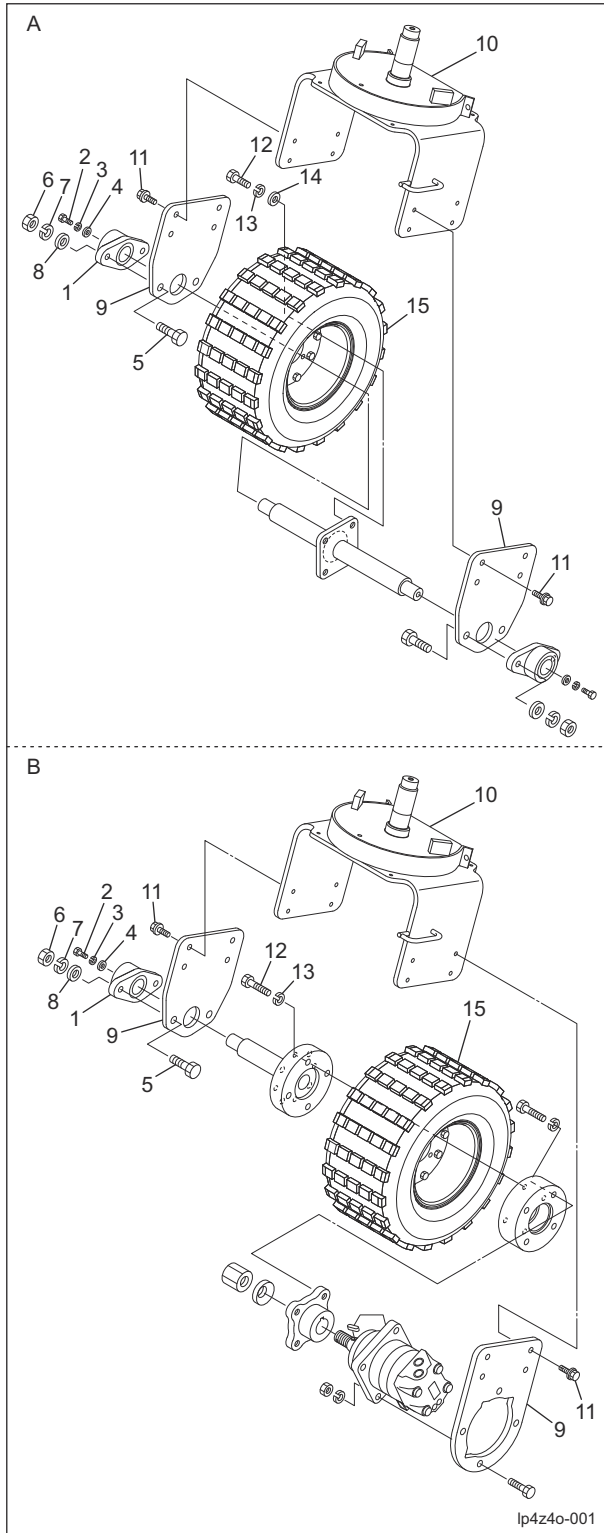

A	2WD specifications
B	3WD specifications
1	Rhombic flange unit
2	Bolt A
3	Spring washer A
4	Washer A
5	Bolt B
6	Nut B
7	Spring washer B
8	Washer B
9	Front wheel bracket
10	Front wheel arm
11	Bolt C
12	Wheel mounting bolt
13	Spring washer C
14	Washer C
15	Front wheel

Maintenance

2. Installing a front tire

Important

Tighten the bolts in the tightening order (crosswise).

Important

Tighten the wheel mounting bolts on the specified torque by using a torque wrench.

For installing the front tire, reverse the removing procedure.

Replacement of Front Tire_001

Maintenance

■ Replacement of Rear Tires

1. Removing rear tires

Follow the steps below to remove the rear tires:

[1] Loosen the bolts.

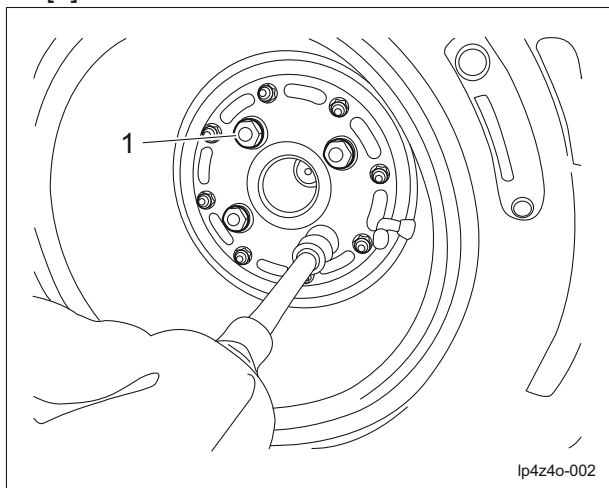

Replacement of Rear Tires_001

1	Bolt
---	------

[2] Securely place the jack beneath the jack-up point of the rear left/right frame area, and then raise it until the tire lifts off the ground.

"Jack-Up Points" (Page 6-2)

[3] Remove the bolts.

[4] Remove the tire from the wheel mounting seat.

2. Installing rear tires

Important

Tighten the bolts in the tightening order (crosswise).

Important

Tighten the wheel mounting bolts on the specified torque by using a torque wrench.

For installing the rear tires, reverse the removing procedure.

Replacement of Fork Prong Bar

⚠ Caution

Wear gloves when touching a fork prong bar.

When wear of the fork prong bar results in no margin for tightening the nut on the fork prong bar, replace the fork prong bar.

1. Loosen the nut, and then replace the fork prong bar.

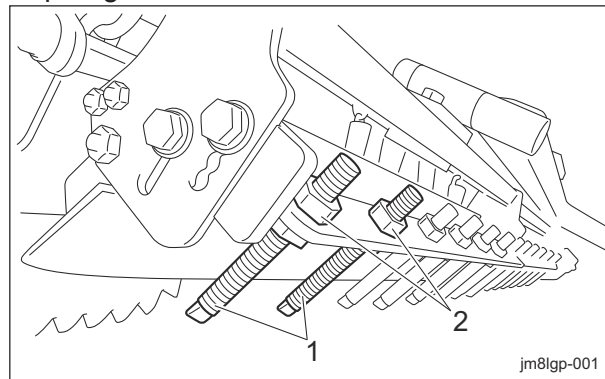

Replacement of Fork Prong Bar_001

1	Fork prong bar
2	Nut

2. Adjust the fork prong bar.

"Adjustment of Rake" (Page 6-12)

3. Tighten the nut.

Replacement of Small Blade

Note:

Depending on the specifications, this function may not be available.

When wear of the small blade causes a reduction in the amount of sand that is lifted up, replace the small blade.

1. Loosen the bolts installing the small blade, and then replace the small blade.

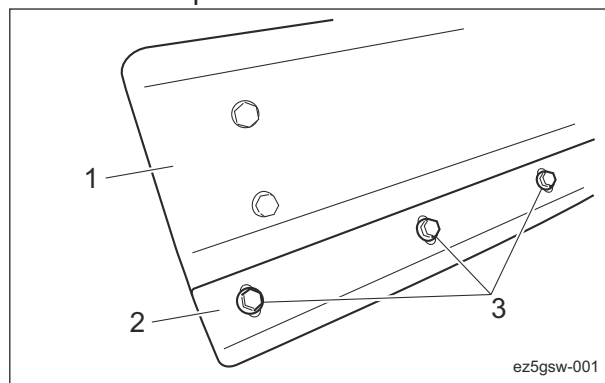

Replacement of Small Blade_001

1	Blade
2	Small blade
3	Bolt

2. Adjust the small blade.

"Adjustment of Blade" (Page 6-13)

3. Tighten the bolts.

Replacement of The Cultivator Fitting

Note:
Depending on the specifications, this function may not be available.

⚠ Caution

When removing the cultivator, be careful not to pinch your hands.

When wear of the trapezoidal cultivator fitting disables unhardening the sand, replace the trapezoidal cultivator fitting.

1. Remove the bolts at the bottom of the machine on the right side.

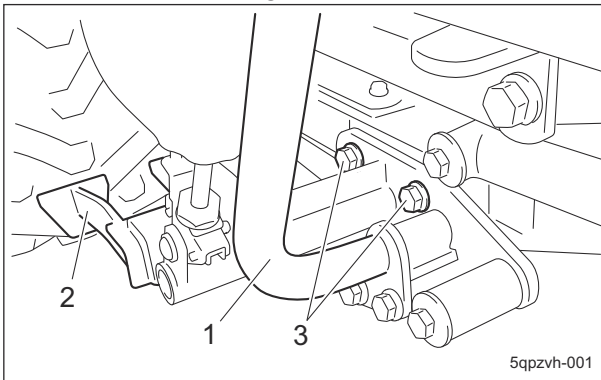

Replacement of The Cultivator Fitting_001

1	Lever pipe
2	Trapezoidal cultivator fitting
3	Bolt

2. Remove the bolts at the bottom of the machine on the left side.

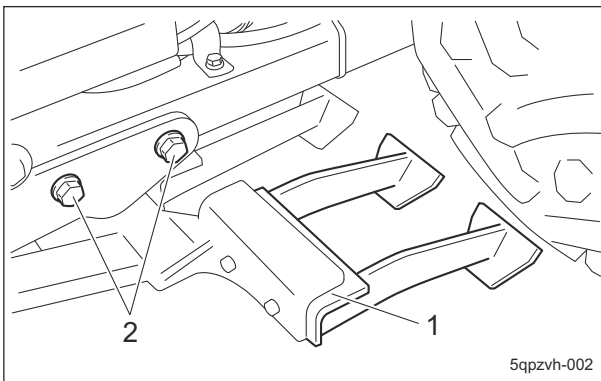

Replacement of The Cultivator Fitting_002

1	Cultivator
2	Bolt

3. Pull out the cultivator from the bottom of the machine.

4. Remove the bolts, and then replace the trapezoidal cultivator fittings.

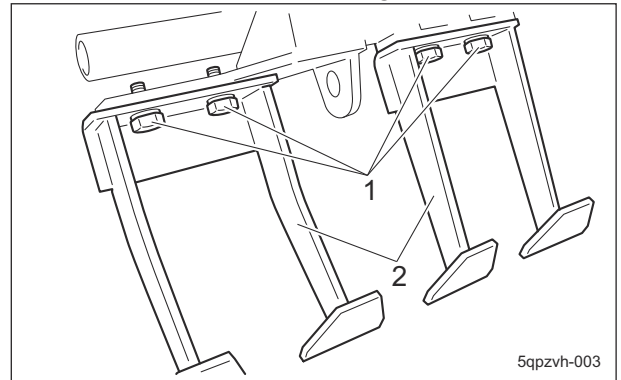

Replacement of The Cultivator Fitting_003

1	Bolt
2	Trapezoidal cultivator fitting

5. Tighten the bolts for the trapezoidal cultivator fitting.

⚠ Caution

When installing the cultivator, pay attention to its falling.

6. Install the cultivator to the machine with bolts.

Maintenance

Replacement of Finishing Brush

Note:

Depending on the specifications, this function may not be available.

⚠ Caution

Be careful since the finishing brush is heavy.

When wear of the finishing brush results in rake tracks remaining, replace the finishing brush.

1. Remove the bolts from the rake, and then remove the finishing brush.

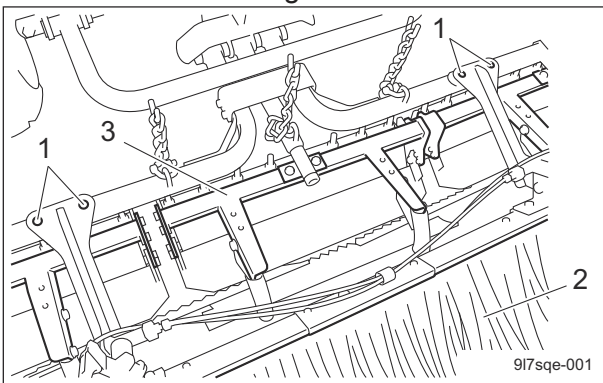

Replacement of Finishing Brush_001

1	Bolt
2	Finishing brush
3	Rake

⚠ Caution

Place the finishing brush on level surface.

2. Remove the bolts, and then replace the finishing brush.

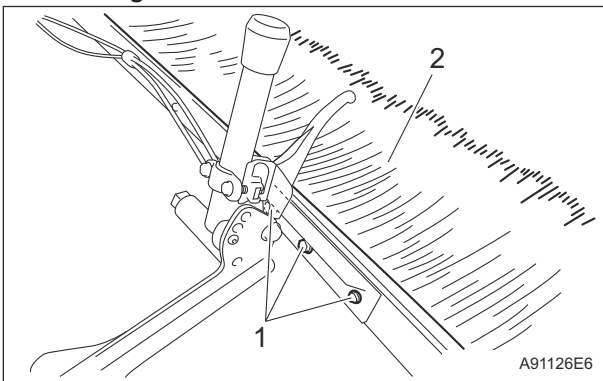

Replacement of Finishing Brush_002

1	Bolt
2	Finishing brush

3. Tighten the bolts.

Storage

Long-Term Storage

Follow the instructions below for long-term storage of the machine.

1. Cleaning

- Remove dirt, grass clippings, oil stains etc. completely from the main vehicle and engine.

2. Replacing oil

- Inspect and replace the engine oil, hydraulic oil and element.

3. Greasing and lubricating

- Supply oil and apply grease to appropriate parts.

4. Battery

- Remove the negative battery wire.

5. Fuel

- Remove the fuel from the fuel tank.

6. Tire pneumatic pressure

- Set the tire air pressure slightly higher than normal, and then place the machine on a board to avoid humidity.

7. Storage location

- Cover the machine and store it in a dry place where it will not be exposed to rain.

Precautions for Repair Page 7-2

Adjustment Page 7-2

Adjustment of Steering Chain Page 7-2

Adjustment of Brake Page 7-2

Adjustment of The Neutral Position
of The Piston Pump Page 7-4

Replacement Page 7-5

Replacement of Fuse Page 7-5

TowingPage 7-6

Towing The Machine in An
EmergencyPage 7-6



Repair

Precautions for Repair

Warning

The chapter "Repair" in this manual describes practical measures which should be performed by a mechanic with expertise. The owner should instruct the mechanic with expertise to perform repair service for this machine.

Caution

First, learn well the operations you plan to perform.

Important

Use tools appropriate for each operation.

Important

Use Baroness genuine parts for replacement and accessories. Our product warranty may be void if you use non-genuine parts for replacement or accessories.

Adjustment

Adjustment of Steering Chain

Excessive play with a loose steering chain may stretch the chain further while you may feel a heavy steering wheel with an excessively tight chain and the chain and wheel may wear prematurely.

Important

Make sure that the steering chain has the specified amount of slack.

1. Open the front cover.

2. With the nuts on each end of the steering chain, adjust the chain tension so that there is approximately 5 mm (0.20 in) of slack.

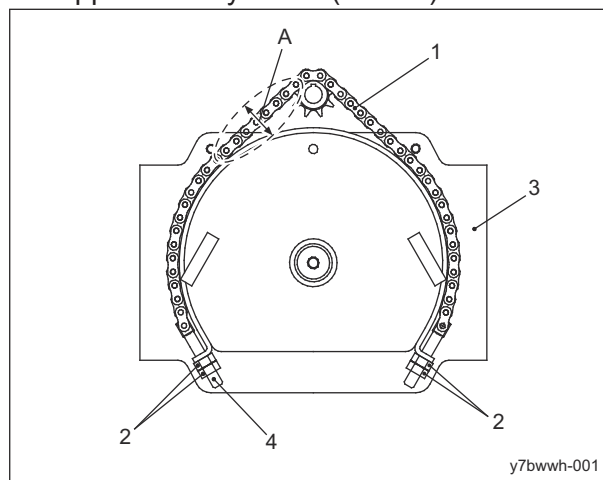

Adjustment of Steering Chain_001

1	Steering chain
2	Nut
3	Front wheel arm
4	Adjustment screw
A	5 mm (0.20 in)

3. After making adjustments, firmly secure the nuts.

Adjustment of Brake

Caution

Make sure that the brake wire is not cracked or damaged.

Caution

If the brake is not sufficiently effective, adjust the brake wire.

Caution

Perform the adjustment with the engine stopped.

Adjust the brake by tightening the brake wire adjustment bolt and the spring rod.

Adjustment of Adjustment Bolt

When the brake wire is stretched, the play of the brake pedal may become large, the braking effectiveness may become worse and the brake pedal may lock.

Important

Adjust the play of the brake lever so that it is as small as possible and the brakes do not drag when the lever is released.

Adjust the brake wire adjustment bolts to adjust the pull length for the brake lever.

- If the brake lever play is too large, the braking power will be decreased and the brake pedal will be soft.
- If the brake lever play is too small, the braking power will be increased and the brake pedal will be hard.

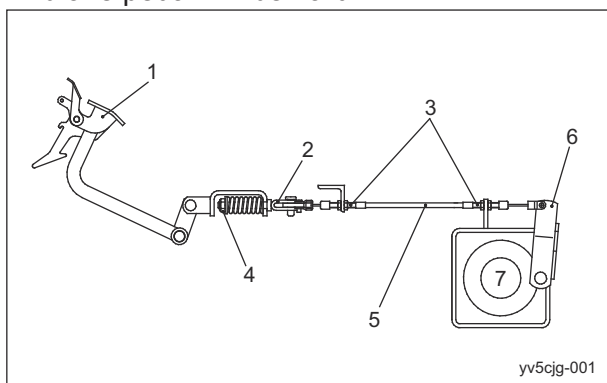

Adjustment of Adjustment Bolt_001

1	Brake pedal
2	Spring rod
3	Adjustment bolt
4	Nut
5	Brake wire
6	Brake lever
7	Rear wheel

Adjustment of Spring Rod

If the spring becomes shorter from depressing the brake pedal, the brakes may become insufficiently effective.

Adjust the spring rod nut to adjust the braking power and operating force of the brake pedal.

- If the brake lever play is too large, the braking power will be weak and the brake pedal will be soft.

- If the brake lever play is too small, the braking power will be excessive and the brake pedal will be hard.

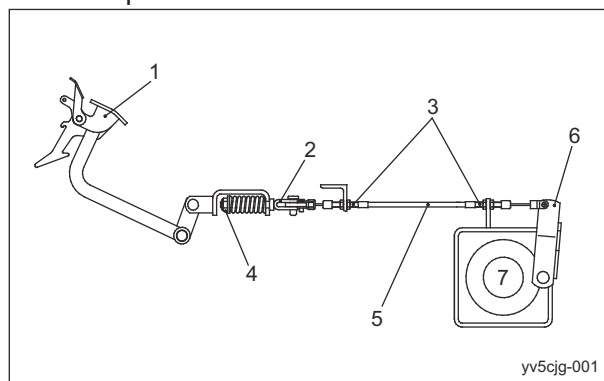

Adjustment of Spring Rod_001

1	Brake pedal
2	Spring rod
3	Adjustment bolt
4	Nut
5	Brake wire
6	Brake lever
7	Rear wheel

Break-In of Brakes

If the brake shoes or brake pads are worn, replace them with new ones.

Immediately after replacement, drive to break in the brakes if the effectiveness of the brakes is low.

While driving, lightly operate the brakes to break in the contact areas.

Repair

Adjustment of The Neutral Position of The Piston Pump

If the machine moves forward or backward while the traveling pedals are released, they are not set to the neutral position.

Follow the steps below to make adjustments.

1. Stop the engine.
2. Remove the cotter pin and washer at the pedal end, and then remove the end of the push-pull cable.

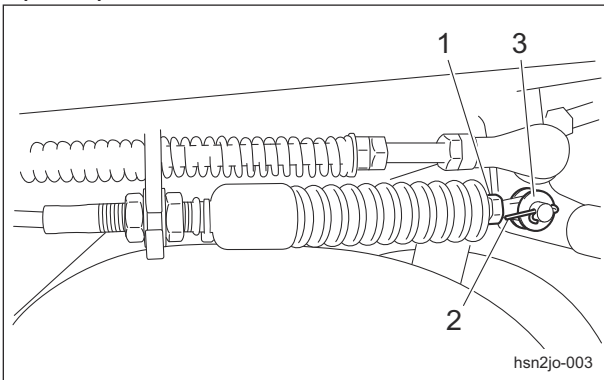

Adjustment of The Neutral Position of The Piston Pump_001

1	Push-pull cable
2	Cotter pin
3	Washer

3. Place the jacks securely beneath the jack-up points, and then lift the machine off the ground.

Use stable jack stands, and raise the machine until the tires lift off the ground. "Jack-Up Points" (Page 6-2)

4. Start the engine, and rev it up to the maximum rpm.
5. Set the drive setting to 2WD mode (rear-wheel 2WD).

Warning

When adjusting the neutral position, exercise care so that the hand does not get entangled in the rotating parts.

6. Slowly turn the camshaft until the rear wheel stops, and then use the nut to lock the camshaft at the stopped position.

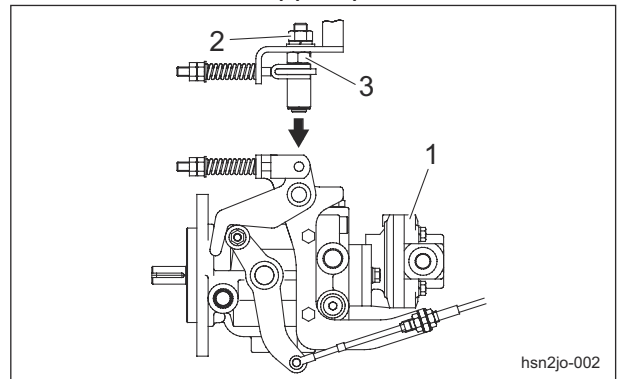

Adjustment of The Neutral Position of The Piston Pump_002

1	Piston pump
2	Nut
3	Camshaft

7. Loosen the lock nuts.

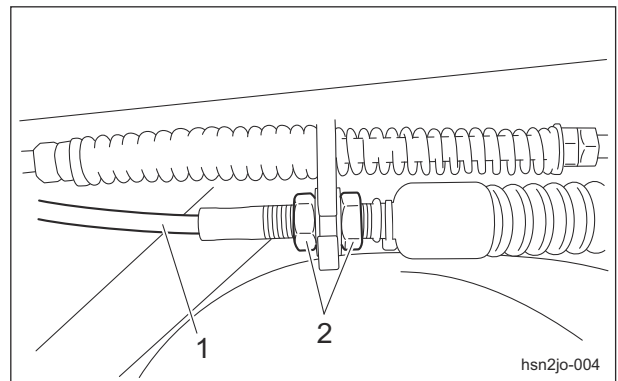

Adjustment of The Neutral Position of The Piston Pump_003

1	Push-pull cable
2	Lock nuts

8. Adjust the end of the push-pull cable at the pedal end so that it attaches to the connection point on the pedal, and then tighten the lock nuts.

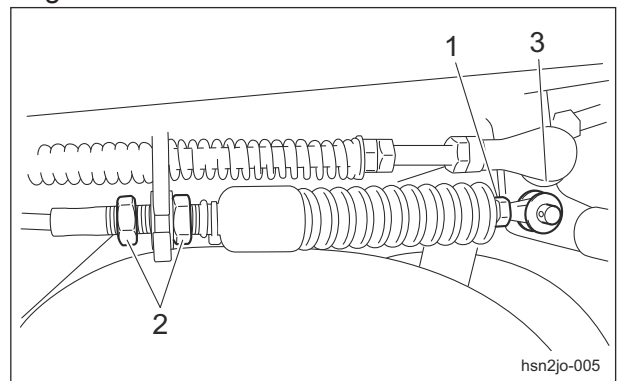

Adjustment of The Neutral Position of The Piston Pump_004

1	Push-pull cable
2	Lock nuts
3	Connection point on pedal

9. Insert the push-pull cable, and then install the washer and cotter pin.

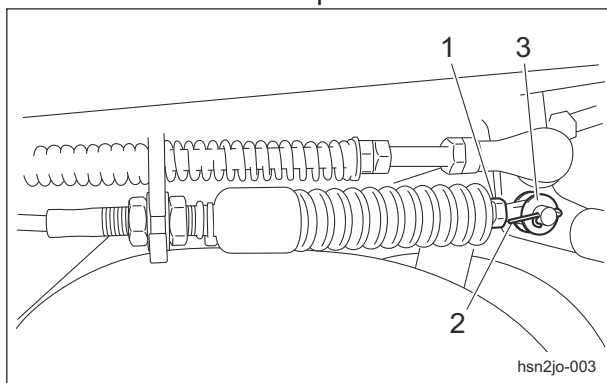

Adjustment of The Neutral Position of The Piston Pump_005

1	Push-pull cable
2	Cotter pin
3	Washer

Replacement

Replacement of Fuse

Important

When performing maintenance on the electrical system, be sure to remove the negative battery wire.

Important

If a fuse blows, a short may have occurred within the electrical circuit. Check for the cause, such as faulty terminal connections, damaged wiring or terminals, or incorrect wiring.

Important

For fuse replacement, clean the fuse mounting area with use of compressed air before mounting the fuse.

Fuses

The fuses consist of the main harness fuses for the entire circuit, the light harness fuse and the starter harness fuse. The fuse capacities are all 20 A.

■ Lower right inside the front cover
Main harness fuse

- #21506 - 21931: Glass fuse
- #21932-: Mini blade fuse

Light harness fuse

- #21506-: Mini blade fuse

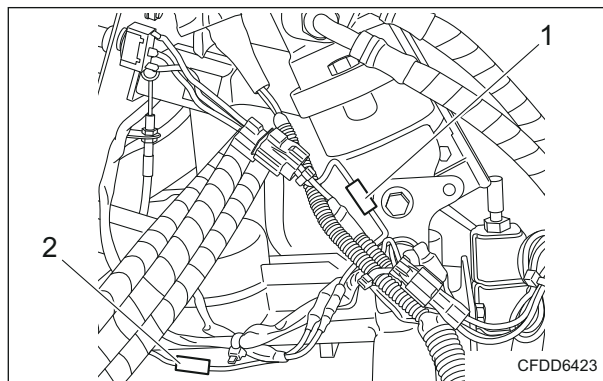

Fuses_001

1	Main harness fuse
2	Light harness fuse

■ Lower right inside the rear cover
Main harness fuse

- #21932-: Mini blade fuse

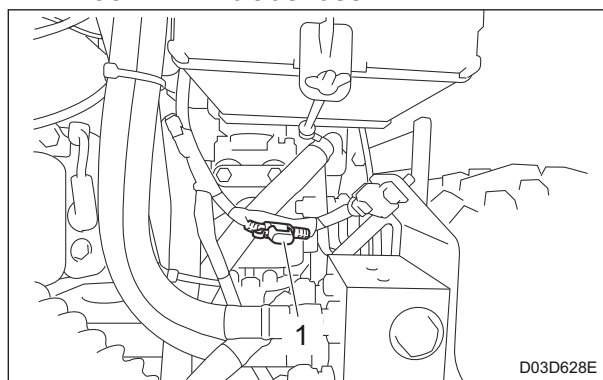

Fuses_002

1	Main harness fuse
---	-------------------

Starter harness fuse

- #21952-: Mini blade fuse

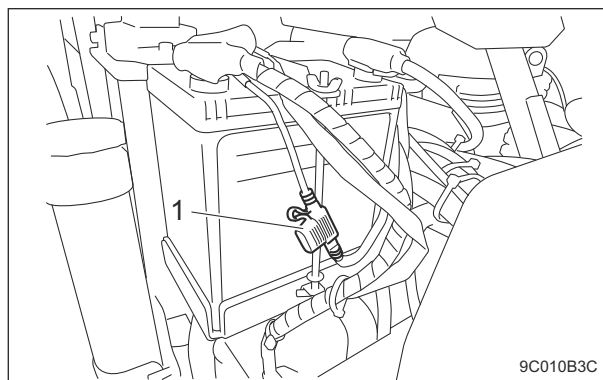

Fuses_003

1	Starter harness fuse
---	----------------------

Towing

Towing The Machine in An Emergency

If the machine does not travel due to engine trouble, etc., you can move it by towing it.

⚠ Caution

Do not tow the machine on a slope.

Important

Do not touch the unload valve except when towing the machine.

Important

Before restarting the engine, be sure to close the bypass.

Important

When towing the machine, obey the following restrictions.

Obey the speed and the time restrictions to prevent damaging the pump or motor.

- Speed: Do not travel at a speed more than 3.0 km/h.
- Time: Do not tow the machine for more than 3 minutes.

When towing the machine for more than 3 minutes, start the engine and circulate the hydraulic oil in the hydraulic circuit.

Therefore, do not tow the machine until restart the engine after completed repairs.

1. Stop the engine.
"Procedure to Stop Engine" (Page 5-11)
2. Apply the parking brake.
3. Chock the wheels.

4. Secure the machine with ropes.

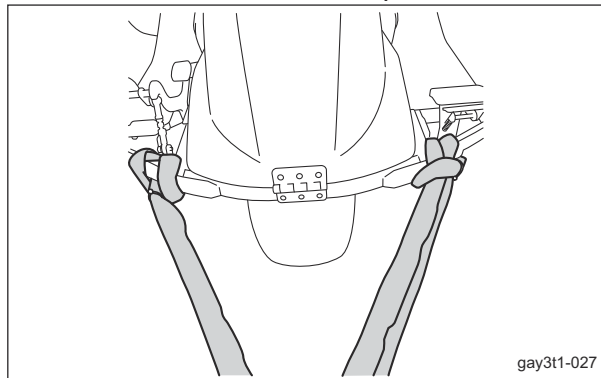

Towing The Machine in An Emergency_001

5. Release the cover fastener.

6. Open the rear cover, and then lift it until the gas spring is fully extended.

Important

When pushing in the unload valve operating pins, be careful about overtightening the bolts. It will damage the unload valve operating pins.

Important

For unloading, be sure to open the two unload valves. Opening only one unload valve will cause the hydraulic system to malfunction.

7. Open the bypass.

- [1] Loosen the lock nut on each of the two unload valves.
- [2] Tighten the two bolts to push in the unload valve operating pins.
- [3] Tighten the lock nut on each of the two unload valves.

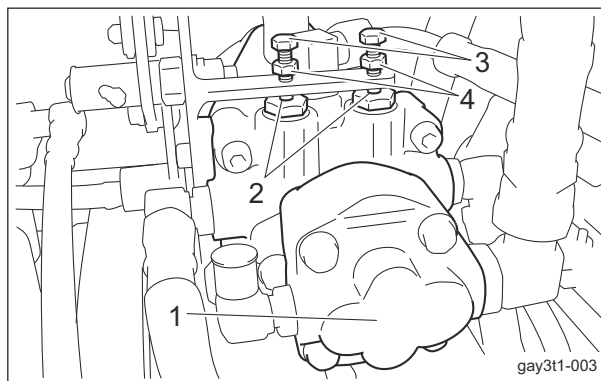

Towing The Machine in An Emergency_002

1	Piston pump
2	Unload valve operating pins
3	Bolt
4	Lock nut

8. Remove the wheel stopper.

9. Release the parking brake.

 **Warning**

While towing, always keep your foot on the brake pedal so that you can depress the brake pedal at any time to stop.

10. Tow the machine slowly.

11. After towing is completed, close the bypass.

[1] Loosen the lock nut on each of the two unload valves.

[2] Loosen the two bolts to return the unload valve operating pins to their original positions.

[3] Tighten the lock nut on each of the two unload valves.

Repair

Appended Table

Tightening Torques	Page 8-2
Standard Tightening Torques	Page 8-2
Principal Tightening Torques	Page 8-5
Daily Check List	Page 8-6
Maintenance Schedule	Page 8-7
List of Adjusted Values	Page 8-8

Appended Table

Tightening Torques

Important

Refer to the Tightening Torque table.
Note that the Baroness product warranty may not apply to defects caused by incorrect or overtorque tightening, etc.

Standard Tightening Torques

Bolts and Nuts



Important

A number of bolts are used in each part of this machine.
Be sure to re-tighten the bolts and nuts, because they may be loosened at the earlier stage of the use.

- As to the bolts and nuts without any special instruction, tighten them in appropriate tightening torque with proper tool.
Too much tightening may cause the looseness or damage of the screw.
- The strength of tightening is determined by types of screws, strength, the friction of thread face or base face and others.
The table below is for the galvanized or parkerized bolts.
In case that the strength of internal thread is weak, it is not applied.
- Do not use rusty or sand attached "screw."
Otherwise, it may cause insufficient tightening even if you apply the specified tightening torque.
The friction of the screw face becomes higher and the tightening torque is canceled out by the friction, therefore sufficient tightening cannot be applied.
- If "screw" is wet by water or oil, do not tighten it with normal tightening torque.
If the screw is wet, the torque coefficient will get smaller and it may result in too much tightening.
Too much tightening may cause looseness by the screw stretched or result in damage.
- Do not use a bolt experienced too much burden.
- Using the impact wrench requires the skill.
Do exercise as much as possible for steady tightening.

Appended Table

Nominal diameter	General bolt		
	Strength classification 4.8		
	 tib3yb-001		
	N-m	kgf-cm	lb-in
M5	3 - 5	30.59 - 50.99	26.55 - 44.26
M6	7 - 9	71.38 - 91.77	61.96 - 79.66
M8	14 - 19	142.76 - 193.74	123.91 - 168.17
M10	29 - 38	295.71 - 387.49	256.68 - 336.34
M12	52 - 67	530.24 - 683.20	460.25 - 593.02
M14	70 - 94	713.79 - 958.52	619.57 - 831.99
M16	88 - 112	897.34 - 1142.06	778.89 - 991.31
M18	116 - 144	1,182.85 - 1,468.37	1,026.72 - 1,274.54
M20	147 - 183	1,498.96 - 1,866.05	1,301.10 - 1,619.73
M22	295	3,008.12	2,611.05
M24	370	3,772.89	3,274.87
M27	550	5,608.35	4,868.05
M30	740	7,545.78	6,549.74

Nominal diameter	Heat-treated bolt					
	Strength classification 8.8			Strength classification 10.9		
	 tib3yb-002			 tib3yb-003		
	N-m	kgf-cm	lb-in	N-m	kgf-cm	lb-in
M5	5 - 7	50.99 - 71.38	44.26 - 61.96	7 - 10	71.38 - 101.97	61.96 - 88.51
M6	8 - 11	81.58 - 112.17	70.81 - 97.36	14 - 18	142.76 - 183.55	123.91 - 159.32
M8	23 - 29	234.53 - 295.71	203.57 - 256.68	28 - 38	285.52 - 387.49	247.83 - 336.34
M10	45 - 57	458.87 - 581.23	398.30 - 504.51	58 - 76	591.43 - 774.97	513.36 - 672.68
M12	67 - 85	683.20 - 866.75	593.02 - 752.34	104 - 134	1,060.49 - 1,366.40	920.50 - 1186.03
M14	106 - 134	1,080.88 - 1,366.40	938.21 - 1,186.03	140 - 188	1,427.58 - 1,917.04	1,239.14 - 1,663.99
M16	152 - 188	1,549.94 - 1,917.04	1,345.35 - 1,663.99	210 - 260	2,141.37 - 2,651.22	1,858.71 - 2,301.26
M18	200 - 240	2,039.40 - 2,447.28	1,770.20 - 2,124.24	280 - 340	2,855.16 - 3,466.98	2,478.28 - 3,009.34
M20	245 - 295	2,498.27 - 3,008.12	2,168.50 - 2,611.05	370 - 450	3,772.89 - 4,588.65	3,274.87 - 3,982.95
M22	-	-	-	530	5,404.41	4,691.03
M24	-	-	-	670	6,831.99	5,930.17
M27	-	-	-	1,000	10,197.00	8,851.00
M30	-	-	-	1,340	13,663.98	11,860.34

Note:
The same values are applied to "fine screw thread."

Appended Table

Hydraulic Hose

The tightening torques for union joints and union adaptors with parallel pipe threads (G, PF) are shown in the table below.

A union joint or adaptor will not become loose or leak as long as it is tightened by the specified torque.

If fluid leaks from the sealed portion, do not attempt to tighten the union joint or adaptor forcibly.

Examine whether any foreign matter or scratches are present on the seat surface.

Tightening a union joint or adaptor forcibly could damage the connection of the joints.

When tightening a union joint or adaptor, use a torque wrench where possible and firmly tighten it by an appropriate torque.

Nominal diameter of the hose size	Nominal diameter of the parallel pipe threads (G, PF)	Tightening torque		
		N-m	kgf-cm	lb-in
6	1/4	25	254.93	221.28
9	3/8	50	509.85	442.55
12	1/2	60	611.82	531.06
15	3/4	120	1,223.64	1,062.12
19	3/4	120	1,223.64	1,062.12
25	1	140	1,427.58	1,239.14
32	1-1/4	170	1,733.49	1,504.67
38	1-1/2	210	2,141.37	1,858.71
50	2	250	2,549.25	2,212.75

Fittings with Parallel Threads (O-Ring Seal Type)

The tightening torques for fittings with parallel threads (O-ring seal method) are shown in the table below.

Tightening the fitting forcibly with a spanner or other such tool to secure it to a set position could damage the fitting, its washers, and other parts.

When tightening an adjustable elbow, use a torque wrench where possible and firmly tighten it by an appropriate torque.

Nominal diameter of thread	Tightening torque		
	N-m	kgf-cm	lb-in.
1/4	34.32 - 49.03	349.96 – 499.96	303.77 – 433.96
3/8	68.65 - 78.45	700.02 – 799.95	607.62 – 694.36
1/2	98.07 - 117.68	1,000.02 – 1,199.98	868.02 – 1,041.59
3/4	147.10 - 176.52	1,499.98 – 1,799.97	1,301.98 – 1,562.38
1	245.17 - 274.59	2,500.00 – 2,799.99	2,170.00 – 2,430.40
1-1/4	294.20	2,999.96	2,603.96
1-1/2	294.20	2,999.96	2,603.96
2	392.27	3,999.98	3,471.98

Appended Table

Principal Tightening Torques

Tightening Torque by Model

SP05A

Tighten the following bolts and nuts at the torque specified in the table.

For thread locking adhesive, apply a middle strength thread locker (ThreeBond 1322 or equivalent anaerobic sealant).

Location		Code	Part name	Tightening torque			Thread locking adhesive
				N-m	kgf-cm	lb-in	
2WD front wheel	Front wheel bracket	K0000100202	Bolt, M10-20	29 - 38	295.71 - 387.49	256.68 - 336.34	-
	Wheel	K0011120302	Bolt, heat-treated M12-30P1.5	67 - 85	683.20 - 866.75	593.02 - 752.34	-
	Rhombic flange unit	K0661205000	Rhombic flange unit UCFL205	-	-	-	M6 set screw
3WD front wheel	Front wheel bracket	K0000100202	Bolt, M10-20	29 - 38	295.71 - 387.49	256.68 - 336.34	-
	Motor mounting base	K0160000492	24 special nut P1.5	180 - 200	1835.46 - 2039.40	1593.18 - 1770.20	-
	Wheel	K0014120602	Bolt, heat-treated M12-60P1.5	67 - 85	683.20 - 866.75	593.02 - 752.34	-
	Spacer	K0014120502	Bolt, heat-treated M12-50P1.5	67 - 85	683.20 - 866.75	593.02 - 752.34	-
	Rhombic flange unit	K0661205000	Rhombic flange unit UCFL205	-	-	-	M6 set screw
Front wheel arm		K0010100502	Bolt, heat-treated M10-50	29 - 38	295.71 - 387.49	256.68 - 336.34	-
Rear wheel	Wheel	K0011120302	Bolt, heat-treated M12-30P1.5	67 - 85	683.20 - 866.75	593.02 - 752.34	-
	Wheel mounting base	K0160000492	24 special nut P1.5	180 - 200	1,835.46 - 2,039.40	1,593.18 - 1,770.20	M24 screw
Oil cooler port fitting		K3006000022-Y	ELBOW, ODD SIZED PT1/2*PF3/8	10 - 25	101.97 - 254.93	88.51 - 221.28	-
Proximity switch NO V-out		K0000050202	BOLT, M5-20	2.5	25.49	22.13	-
Battery terminal		K3612000090	TERMINAL, BATTERY (+) 4013-39-1	9	91.77	79.66	-
		K3612000100	TERMINAL, BATTERY (-) 4013-39-2	9	91.77	79.66	-

Appended Table

Daily Check List

SP05A

- . . . Inspect, adjust, supply, clean (first time)
- . . . Inspect, adjust, supply, clean
- ▲ . . . Replace (first time)
- △ . . . Replace

Maintenance Item		Before Work	After Work	Remarks
Engine	*1	Check engine oil	○	
	*1	Check fuel	○	
		Check fuel filter	○	
		Check fuel strainer	○	
		Check air cleaner	○	
		Check engine area	○	
	*1	Clean engine area		○
Main vehicle		Check hydraulic oil	○	
		Check tire	○	
	*2	Check battery	○	
		Check oil cooler	○	
		Check cover	○	
		Check wire	○	
		Check traveling pedal	○	
		Check brake pedal	○	
		Check parking brake	○	
		Check steering wheel	○	
		Check oil or water leaks	○	
		Check machine exterior	○	
		Check bolts and nuts	○	
		Check hour meter	○	
		Check interlock system	○	
		Check light	○	
		Check rake	○	
		Check blade	○	
		Check cultivator	○	
		Check finishing brush	○	
	Clean oil cooler		○	
	Clean machine exterior		○	

- *1: Refer to the Engine's Owner's Manual.
- *2: Refer to the Battery's Owner's Manual.

Appended Table

Maintenance Schedule

SP05A

Follow the maintenance schedule below.

- . . . Inspect, adjust, supply, clean (first time)
- . . . Inspect, adjust, supply, clean
- ▲ . . . Replace (first time)
- △ . . . Replace

Maintenance Item		Before work	After work	Every 50 hrs.	Every 100 hrs.	Every 200 hrs.	Every 250 hrs.	Every 400 hrs.	Every 500 hrs.	Every month	Every year	Every 2 years	Every 4 years	When Required	Remarks
Engine	Clean air cleaner element		○												
	Clean fuel strainer				○										
	*1 Check muffler				○										
	*1 Check valve clearance						○								
	*1 Replace engine oil			▲	△										
	*1 Replace engine oil filter			▲	△										
	*1 Replace spark plug				△										
	Replace air cleaner element					△									
	*1 Replace fuel filter							△			△				Check every 400 hours or every year whichever comes earlier
	Replace fuel hoses and clamp bands											△			
Main vehicle	Check hydraulic hose (Moving part)	○													
	Check belt	○													
	Check steering chain	○													
	Check electrical wiring			●	○										
	Check wheel mounting bolts			●	○										
	Check hydraulic hose (Fixed part)				○					○					Check every 100 hours or every month whichever comes earlier
	Grease and Lubricate			○											
	Replace hydraulic oil				▲				△						
	Replace hydraulic oil line filter				▲				△						
	Replace air breather element				▲				△						
*2 Replace battery											△				

Appended Table

Appended Table

Maintenance Item		Before work	After work	Every 50 hrs.	Every 100 hrs.	Every 200 hrs.	Every 250 hrs.	Every 400 hrs.	Every 500 hrs.	Every month	Every year	Every 2 years	Every 4 years	When Required	Remarks
Main vehicle	*3	Replace hydraulic hoses (Moving part)										△			
	*3	Replace hydraulic hoses (Fixed part)											△		
		Replace Belt												△	
	*3	Replace brake wire												△	
	*3	Replace traveling cable												△	
		Replace throttle wire												△	
		Replace choke wire												△	
	*3	Replace brake shoe												△	

- *1: Refer to the Engine's Owner's Manual.
- *2: Refer to the Battery's Owner's Manual.
- *3: Consult your local Baroness Dealer for this service.
- The values for consumables are not guaranteed.

List of Adjusted Values

Pump drive belt		10 mm (0.39 in)	Belt slack when belt pressed with 98 N (10 kgf) at the middle point between pulleys.
Steering chain		5 mm (0.20 in)	Steering chain slack
Rake	Fork depth (standard)	15 mm (0.59 in)	
Blade	Arm stopper	23 mm (0.91 in)	
	Raised height	200 mm (7.87 in)	
	Exposed length of screw shaft from spherical joint	65 mm (2.56 in)	
	Exposed length of threaded end of connecting shaft	20 mm (0.79 in)	
	Installation depth of spherical joint	15 mm (0.59 in)	

Records

Daily Check Records Page 9-2

Maintenance RecordsPage 9-5

Records

Records

Daily Check Records

SP05A

Use this table freely for your records of the daily check.

Model		Serial Number	
-------	--	---------------	--

Items										
Engine	Check engine oil									
	Check fuel									
	Check fuel filter									
	Check fuel strainer									
	Check air cleaner									
	Check engine area									
	Clean engine area									
Main vehicle	Check hydraulic oil									
	Check tire									
	Check battery									
	Check oil cooler									
	Check cover									

Records

Items											
Main vehicle	Check wire										
	Check traveling pedal										
	Check brake pedal										
	Check parking brake										
	Check steering wheel										
	Check oil or water leaks										
	Check machine exterior										
	Check bolts and nuts										
	Check hour meter										
	Check interlock system										
	Check light										
	Check rake										
	Check blade										
	Check cultivator										

Records

Records

Items											
Main vehicle	Check finishing brush										
	Clean oil cooler										
	Clean machine exterior										

Maintenance Records

SP05A

Use this table freely for your records of the maintenance.

Model		Serial Number	
-------	--	---------------	--

Items											
Engine	Clean air cleaner element										
	Clean fuel strainer										
	Check muffler										
	Check valve clearance										
	Replace engine oil										
	Replace engine oil filter										
	Replace spark plug										
	Replace air cleaner element										
	Replace fuel filter										
	Replace fuel hoses and clamp bands										
Main vehicle	Check hydraulic hose (Moving part)										
	Check belt										

Records

Records

Items											
Main vehicle	Check steering chain										
	Check electrical wiring										
	Check wheel mounting bolts										
	Check hydraulic hose (Fixed part)										
	Grease and Lubricate										
	Replace hydraulic oil										
	Replace hydraulic oil line filter										
	Replace air breather element										
	Replace battery										
	Replace hydraulic hoses (Moving part)										
	Replace hydraulic hoses (Fixed part)										
	Replace Belt										
	Replace brake wire										
Replace traveling cable											

Records

Items											
Main vehicle	Replace throttle wire										
	Replace choke wire										
	Replace brake shoe										

Records

Records

BARONESS[®]
Quality on Demand

 **KYOEISHA CO., LTD.**
Head Office 1-26, Miyuki-cho, Toyokawa-city, Tel :+81-533-84-1390
Aichi-pref, 442-8530 JAPAN Fax:+81-533-84-1220