

# ***LM331***

3-Unit Surround & Trim Mower

## Owner's Operating Manual

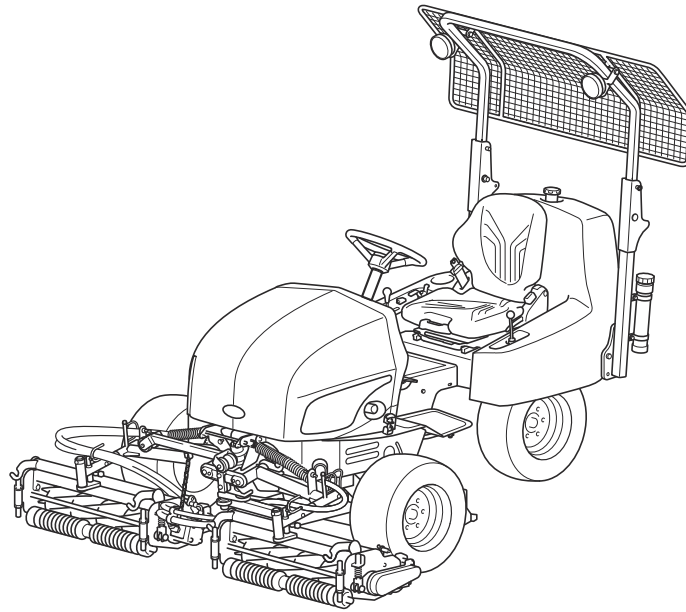

Serial No. LM331 : 20001-

"Required reading"  
Read this manual before using the machine.

---

**BARONESS**<sup>®</sup>  
Quality on Demand

Original Instructions Ver.3.4

# Regulations

## California Proposition 65

(For California, USA)

### WARNING:

Operating, servicing and maintaining a passenger vehicle or off-road vehicle can expose you to chemicals including engine exhaust, carbon monoxide, phthalates, and lead, which are known to the State of California to cause cancer and birth defects or other reproductive harm. To minimize exposure, avoid breathing exhaust, do not idle the engine except as necessary, service your vehicle in a well-ventilated area and wear gloves or wash your hands frequently when servicing your vehicle. For more information go to [www.P65Warnings.ca.gov/passenger-vehicle](http://www.P65Warnings.ca.gov/passenger-vehicle).

318yi8-005

California Proposition 65\_001

## California Spark Arrester

(For California, USA)

### Warning

Operation of this equipment may create sparks that can start fires around dry vegetation.  
A spark arrester may be required.  
The operator should contact local fire agencies for laws or regulations relating to fire prevention requirements.

It is a violation of California Public Resource Code Section 4442 or 4443 to use or operate the engine on any forest-covered, brush-covered, or grass-covered land unless the engine is equipped with a spark arrester, as defined in Section 4442, maintained in effective working order or the engine is constructed, equipped, and maintained for the prevention of fire pursuant to Section 4443.

The engine of this machine is not equipped with a spark arrester.

In some areas there are local, state, or federal regulations requiring that a spark arrester be used on the engine of this machine.

The recommended spark arrester for this machine is Part No.49025N Spark Arrester made by Nelson Global Products.

## EU Regulations

(For EU)

This product complies with all relevant EU Regulations.

For more information, please refer to the Declaration of Conformity attached.

Thank you for purchasing the Baroness product. This manual describes the proper handling, adjustment, and inspection of your product. We hope you will use the product safely, and take advantage of its best performance. For details on the handling, adjustment and inspection of the attachments, refer to the Owner's Operating Manual for the attachments.

**QR Code**

(\*QR Code is a registered trademark of DENSO WAVE INCORPORATED.)  
A QR code label is affixed on the machine.

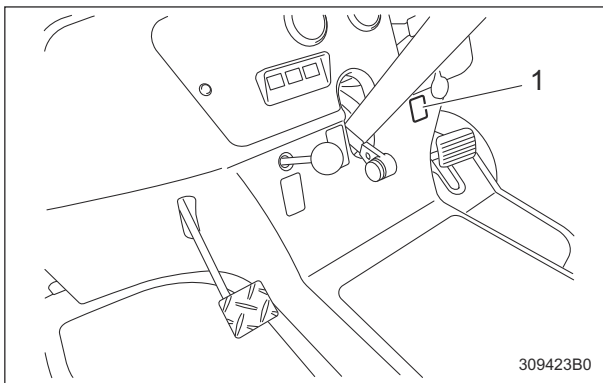

QR Code\_001

1	QR code label
---	---------------

Scan the QR code with your smartphone for easy access to Baroness Manual Reference Service where you can browse Owner's Operating Manual and Parts Catalog.  
<https://doc.baroness-international.com/manuals/LM331>



QR Code\_002

**Note:**  
A QR code for mower unit is printed on the serial number plate.

**Keeping the Owner's Operating Manual**

Keep this Manual in the box on the left side of the ROPS.

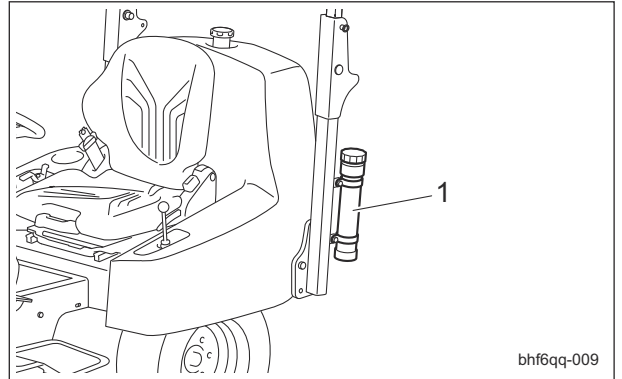

Keeping the Owner's Operating Manual\_001

1	Box
---	-----

# Introduction

---

Read this manual carefully to ensure that you thoroughly understand how to properly operate and maintain the product, and to avoid causing injury to yourself or others.

The operator is responsible for operating the product properly and safely.

Maintenance service for this machine should be performed by a mechanic with expertise.

If you have any questions concerning maintenance or genuine parts, please contact a Baroness dealer or Kyoisha.





When making inquiries about your product, please specify the model and serial number.

When loaning or transferring the product, please also provide this manual together with the product.

Kyoisha Co., Ltd.

## Warning Symbols

This manual uses the following warning symbols for handling precautions that are important for your safety.

 <small>696cq5-001</small>	Warning symbol
<p>This symbol indicates the articles regarding “Danger,” “Warning,” or “Caution.” Those articles describe important safety precautions and so read them carefully to understand completely before operating the machine.</p> <p>Failure to adequately follow these safety precautions may cause an accident.</p>	
<p><b> Danger</b></p> <p>This symbol indicates that serious injury or death will occur if the warning is ignored.</p>	
<p><b> Warning</b></p> <p>This symbol indicates that serious injury or death may occur if the warning is ignored.</p>	
<p><b> Caution</b></p> <p>This symbol indicates that injury or damage to property may occur if the warning is ignored.</p>	
<p><b>Important</b></p> <p>This symbol indicates precautions on the mechanism of the machine.</p>	

## Precautionary Statement

### Caution

The information described in this manual is subject to change for improvement without prior notice.

When replacing parts, be sure to use genuine Baroness parts or parts designated by Kyoisha.

Note that the Baroness product warranty may not apply to defects caused by the use of parts from other companies.

Prior to use, carefully read the following manuals to thoroughly understand the contents for safe and correct operation.

- Baroness Owner's Operating Manual
- The Engine's Owner's Manual
- The Battery's Owner's Manual

## Purpose

This product is intended for cutting turf grass at golf courses.

Do not use this product in any way other than its intended purpose, and do not modify this product.

Operating this product for other purposes and modifying it may be very dangerous and may cause damage to the product.

In addition, this product is not authorized for operation as a special motor vehicle. Do not operate it on public roads.

LM331

# Introduction

---

<b>Safety</b> .....	<b>Page 1-1</b>	<b>Maintenance</b> .....	<b>Page 6-1</b>
Safe Operating Practices .....	Page 1-2	Precautions for Maintenance .....	Page 6-2
<b>Disposal</b> .....	<b>Page 2-1</b>	Jacking Up The Machine .....	Page 6-2
Recycle and Waste Disposal .....	Page 2-2	Hoisting The Machine .....	Page 6-3
<b>Product Overview</b> .....	<b>Page 3-1</b>	Inspection and Cleaning .....	Page 6-4
Specifications .....	Page 3-2	Supplying Fluids .....	Page 6-9
Names of Each Section .....	Page 3-4	Greasing .....	Page 6-13
Regulation Decals .....	Page 3-7	Lubrication .....	Page 6-17
Safety Signs and Instruction Signs .....	Page 3-12	Adjustment .....	Page 6-18
Operation Decals .....	Page 3-18	Replacement .....	Page 6-22
<b>Description of Functions</b> .....	<b>Page 4-1</b>	Storage .....	Page 6-32
Proximity Sensor .....	Page 4-2	<b>Repair</b> .....	<b>Page 7-1</b>
2WD/3WD Selector Lever .....	Page 4-2	Precautions for Repair .....	Page 7-2
Key Switch .....	Page 4-2	Adjustment and Replacement .....	Page 7-2
Light Switch .....	Page 4-3	Towing .....	Page 7-6
Diff-Lock Switch .....	Page 4-3	<b>Appended Table</b> .....	<b>Page 8-1</b>
Throttle Lever .....	Page 4-3	Tightening Torques .....	Page 8-2
Mower Unit Up/Down Lever .....	Page 4-4	Daily Check List .....	Page 8-7
Reel Rotation Switch .....	Page 4-4	Maintenance Schedule .....	Page 8-8
Reel Reverse Switch .....	Page 4-5	List of Adjusted Values .....	Page 8-12
Reel Rotation/Stop Switching Lever .....	Page 4-5	<b>Records</b> .....	<b>Page 9-1</b>
Traveling Pedal .....	Page 4-5	Daily Check Records .....	Page 9-2
Brake Pedal .....	Page 4-6	Maintenance Records .....	Page 9-5
Parking Brake Lever .....	Page 4-6		
Battery Cutoff Switch .....	Page 4-6		
Instruments in the Meter Panel .....	Page 4-7		
Safety Device .....	Page 4-8		
Warning Mechanisms .....	Page 4-9		
<b>Handling Instructions</b> .....	<b>Page 5-1</b>		
Operations before Service .....	Page 5-2		
Inspection before Use .....	Page 5-4		
Adjustment before Work .....	Page 5-11		
Mounting and Dismounting .....	Page 5-11		
Start/Stop of Engine .....	Page 5-12		
Parking and Stopping .....	Page 5-13		
Move .....	Page 5-14		
Cutting Work .....	Page 5-14		
Transporting .....	Page 5-15		
Cleaning after Use .....	Page 5-15		
Storage .....	Page 5-17		

LM331

# Contents

---

**Safe Operating Practices ..... Page 1-2**

Training ..... Page 1-2

Preparation ..... Page 1-2

Operation ..... Page 1-3

Maintenance ..... Page 1-4

Storage ..... Page 1-5

# Safety

Failure to adequately follow these safety precautions may cause an accident resulting in injury or death.

## Danger

This product is designed to ensure safe operation and has been tested and inspected thoroughly before shipment from the factory. The product is equipped with safety devices to prevent accidents.

However, whether the product demonstrates its original performance level depends on the manner in which it is operated and handled, as well as the manner in which it is managed on a daily basis.

Inappropriate use or management of the product may result in injury or death.

Observe the following safety instructions to ensure safe operation.

## Safe Operating Practices

### Training

1. Read this manual and other training material carefully.

Be familiar with the controls, safety signs, and the proper use of the equipment.

2. If the operator or mechanic can not read the language used in this manual, it is the owner's responsibility to explain this material to them.

3. All operators and mechanics should seek and obtain professional and practical instruction.

The owner is responsible for training the users.

Such instruction should emphasize:

- [1] The need for care and concentration when working with ride-on machines.

- [2] Control of a ride-on machine sliding on a slope will not be regained by the application of the brake.

The main reasons for loss of control are

- Insufficient wheel grip
- Being driven too fast
- Inadequate braking
- The type of machine is unsuitable for its task
- Lack of awareness of the effect of ground conditions, especially slopes
- Incorrect hitching and load distribution

4. Never allow children or people unfamiliar with these instructions to use or service the machine.  
Local regulations may restrict the age of the operator.
5. The owner/user can prevent and is responsible for accidents or injuries occurring to themselves, other people, or property.
6. Keep in mind that the owner, operator, and mechanic are responsible for accidents or hazards occurring to other people or their property.
7. The ROPS is an integral and effective safety device.  
Do not remove or alter the ROPS.
8. Replace a damaged ROPS.  
Do not repair or alter.
9. You can find additional safety information where needed throughout this manual.
10. Determine the left and right sides of the machine from the normal operating position.

### Preparation

1. Evaluate the terrain to determine what accessories and attachments are needed to properly and safely perform the job.  
Only use accessories and attachments approved by the manufacturer.
2. While operating, always wear substantial footwear, long trousers, hard hat, safety glasses, mask, and ear protection.  
Long hair, loose clothing, or jewelry may get tangled in moving parts.  
Do not operate the equipment when barefoot or wearing open sandals.
3. Inspect the area where the equipment is to be used and remove all objects such as rocks, toys and wire which can be thrown by the machine.
4. Keep children out of the operating area and under the watchful care of a responsible adult other than the operator.
5. Exercise care in the handling of fuel.

## Warning

Fuel is highly flammable.  
Take the following precautions:

- [1] Store fuel in containers specifically designed for this purpose.

- [2] Add fuel before starting the engine.  
Never remove the cap of the fuel tank or add fuel while the engine is running or when the engine is hot.
- [3] Refuel outdoors only and do not smoke while refueling.
- [4] If fuel is spilled, do not attempt to start the engine but move the machine away from the area of spillage and avoid creating any source of ignition until petrol vapours have dissipated;
- [5] Replace all fuel tanks and container caps securely.
6. Check that operator's presence controls, safety switches and shields are attached and functioning properly.  
Do not operate unless they are functioning properly.
7. If the brake operation is faulty, be sure to adjust or repair them before operating the machine.
8. Replace faulty mufflers.
9. On multi-cylinder/multi-reel machines, take care as rotating one cylinder/reel can cause other cylinders/reels to rotate.
8. Never operate while people, especially children, or pets are nearby.
9. Only operate in good light, keeping away from holes and hidden hazards.
10. Do not operate the machine when there is the risk of lightning.
11. Do not stop or start suddenly.
12. Look behind and down before backing up to be sure of a clear path.
13. Slow down and use caution when making turns and crossing roads and sidewalks.
14. Use care when approaching blind corners, shrubs, trees, or other objects that may obscure vision.
15. Do not take your eyes off the road ahead.  
Do not operate the machine with no hands.
16. Keep a folding ROPS in the raised and locked position and use the seat belt when operating the machine.
17. Lower a folding ROPS temporarily only when absolutely necessary.  
Do not wear the seat belt when folded down. There is no rollover protection when a folding ROPS is in the down position.
18. Remember there is no such thing as a safe slope.  
Travel on grass slopes requires particular care.  
To guard against overturning, follow these instructions.

## Operation

1. Do not operate the machine under the influence of alcohol or drugs.
2. Do not operate the engine in a confined space where dangerous carbon monoxide fumes can collect.
3. Be sure all drives and shift are in neutral and parking brake is engaged before starting engine.  
Only start engine from the operator's position.  
Use seat belts if provided.
4. Do not change the engine governor settings or overspeed the engine.  
Operating the engine at excessive speed may increase the hazard of personal injury.
5. Never operate the machine with damaged guards, shields, or without safety protective devices in place.  
Be sure all interlocks are attached, adjusted properly, and functioning properly.
6. Keep hands and feet away from the rotating parts.
7. Do not carry passengers.
- [1] Do not stop or start suddenly when going up or downhill.
- [2] Engage clutch slowly, always keep machine in gear, especially when traveling downhill.
- [3] Machine speeds should be kept low on slopes and during turns.
- [4] Stay alert for humps and hollows and other hidden hazards.
19. Never use the machine on a slope with an angle of gradient that is greater than that specified or in a place where there is a danger of the machine slipping.
20. Use extra care while operating machine with a grass catcher or other attachments.  
They can affect the stability of the machine.
21. Disengage drive to the cutting unit(s), when other than operating.

# Safety

---

22. Do the following before leaving the operator's position.
  - [1] Stop on level ground.
  - [2] Disengage the all drives.
  - [3] Set the parking brake.
  - [4] Stop the engine.
  - [5] Remove the ignition key.
23. Stop the engine in the following conditions.
  - [1] Before refuelling.
  - [2] Before removing the grass catcher.
  - [3] Before making height or depth adjustment unless adjustment can be made from the operator's position.
  - [4] Before clearing blockages.
  - [5] Before checking, cleaning or working on the machine.
  - [6] After striking a foreign object or if an abnormal vibration occurs.  
Inspect the machine for damage and make repairs before restarting and operating the equipment.
24. Reduce the throttle setting during engine run-out.
25. Do not direct discharge material toward anyone.  
Avoid discharging material against a wall or obstruction.  
Material may ricochet back toward the operator.
26. Take care when loading or unloading the machine into a trailer or a truck.  
Load or unload the machine in a flat and safe place.  
Before loading or unloading, set the parking brake on the truck or trailer, stop the engine, and chock the wheels.  
When transporting the machine on a truck or a trailer, set the parking brake, stop the engine, and fasten the machine to the truck with a rope or other suitable restraining device that has sufficient strength.  
When using a running board, select one with sufficient strength, length, and width and that will not cause the machine to slip.
27. Close the fuel valve before transporting the machine.
2. Implement the following work before adjusting, cleaning or repairing.
  - [1] Stop the machine on level ground.
  - [2] Disengage drive to the cutting unit(s).
  - [3] Lower the cutting unit(s) and/or attachment(s).
  - [4] Set the parking brake.
  - [5] Stop the engine.
  - [6] Remove the ignition key.
  - [7] Wait for all movement to stop.
3. Allow the engine/muffler to cool before checking/maintenance.
4. To reduce the fire hazard, keep hot parts such as the engine and silencer/muffler, battery compartment and fuel storage area free of grass, leaves, or excessive grease. Clean up oil or fuel spillage.
5. Appropriately manage and correctly use the tools necessary for servicing or adjusting the machine.
6. Disconnect battery before making any repairs.  
Disconnect the negative terminal first and the positive last.  
Reconnect positive first and negative last.
7. Use jack stands to support components when required.
8. Keep hands and feet away from moving parts.  
If possible, do not make adjustments with the engine running.
9. Make sure that parts such as wires are not touching each other and that their covers have not come off.
10. Keep all parts in good working condition and all hardware tightened.  
Replace all worn or damaged decals.
11. Keep all nuts, bolts and screws tight to be sure the equipment is in safe working condition.
12. Carefully release pressure from components with stored energy.
13. Be sure to depressurize the hydraulic system before performing maintenance operations on it such as removing hydraulic equipment.
14. Check whether line connectors in the hydraulic system are properly tightened.  
Before applying hydraulic pressure, check the connections of the hydraulic pressure lines and the condition of the hoses.

## Maintenance

1. Never allow untrained personnel to service machine.

15. When checking the hydraulic circuit for pinhole leaks or oil leakage from nozzles, do not use your hands.  
Use items such as paper or corrugated cardboard to find leakage points.  
Be extremely careful with high-pressure oil as it may pierce your skin, resulting in an injury.  
If fluid is injected into the skin it must be surgically removed within a few hours by a doctor familiar with this form of injury or gangrene may result.
  16. Use care when checking the cylinders/reels and bed knives.  
Wear gloves and use caution when servicing them.
  17. Be careful during adjustment of the machine to prevent entrapment of the fingers between moving blades and fixed parts of the machine.
  18. On multi-cylinder/multi-reel machines, take care as rotating one cylinder/reel can cause other cylinders/reels to rotate.
  19. Check the grass catcher frequently for wear or deterioration.
  20. Charge batteries in an open well ventilated area, away from spark and flames.  
Unplug charger before connecting or disconnecting from battery.  
Wear protective clothing and use insulated tools.
  21. If the fuel tank has to be drained, do this outdoors.
7. Swallowing engine coolant can cause injury or death; keep out of reach from children and pets.

## Storage

1. When machine is to be parked, stored, or left unattended, lower the cutting unit(s) and/or attachment(s) unless a positive mechanical lock is provided.
2. Allow the engine to cool before storing in any enclosure.
3. Only cover the machine with a sheet after hot parts have sufficiently cooled down.
4. Never store the equipment with fuel in the tank inside a building where fumes may reach an open flame or spark.
5. If the engine is provided with a shut-off valve, shut off valve while storing or transporting.
6. Do not store fuel near flames.



**Recycle and Waste Disposal ..... Page 2-2**

About Recycle .....Page 2-2

About Waste Disposal ..... Page 2-2



# Disposal

---

## Recycle and Waste Disposal

### About Recycle

Recycling battery etc. is recommended for environmental conservation and economical use of resources.

It may be required by local laws.

### About Waste Disposal

Make sure that waste generated when servicing or repairing the machine is disposed of in accordance with local regulations. (e.g. waste oil, antifreeze, rubber products, and wires etc.)

**Specifications ..... Page 3-2**

Specifications .....Page 3-2

Mower Units .....Page 3-3

Sound Pressure Level ..... Page 3-3

Sound Power Level ..... Page 3-3

Vibration Level ..... Page 3-3

Carbon Dioxide (CO<sub>2</sub>) Emissions .....Page 3-3**Names of Each Section ..... Page 3-4****Regulation Decals .....Page 3-7**

Positions of Regulation Decals ..... Page 3-7

Description of Regulation Decals ..... Page 3-7

**Safety Signs and Instruction Signs ... Page 3-12**About Safety Signs and Instruction  
Signs .....Page 3-12Positions of Safety Decals and  
Instruction Decals ..... Page 3-12Description of Safety Decals and  
Instruction Decals ..... Page 3-14**Operation Decals ..... Page 3-18**

Positions of Operation Decals ..... Page 3-18

Description of Operation Decals ..... Page 3-20

# Product Overview

## Specifications

### Specifications

Model		LM331	
Name		3-Unit Surround & Trim Mower	
Mower unit type		26 in	
Dimensions	Total length		254 cm 100.00 in
	Total width		212 cm 83.46 in
	Total height	Steering wheel	126 cm 49.61 in
		ROPS	196 cm 77.17 in
Weight	Machine (3WD, empty fuel tank)	LH66 with groomer, CR brush, ROPS, Light, Ball proof net without grass catcher	923 kg 2,034.87 lb
		LS66 with CR brush, ROPS, Light, Ball proof net without grass catcher	875 kg 1,929.04 lb
	Grass catchers (for one machine)		15.0 kg 33.07 lb
	Minimum turning radius		
		LH66	Front wheel (outer wheel) outside 198 cm 77.95 in
			Outer side of unit 228 cm 89.76 in
		LS66	Front wheel (outer wheel) outside 198 cm 77.95 in
			Outer side of unit 227 cm 89.37 in
Engine	Model		Kubota D902-E4B
	Type		Vertical Water-cooled 4-cycle diesel engine
	Total displacement		898 cm <sup>3</sup> (0.898 L) 54.79 cu.in.
	Maximum output		-
	Rated output		13.4 kW (18.2 PS)/2,600 rpm
Fuel tank capacity		Diesel 25.0 dm <sup>3</sup> (25.0 L) Diesel 6.61 U.S.gals	
Fuel consumption		257 g/kW · h (rated output) 189.0 g/PS · h (rated output)	
Engine oil capacity		3.7 dm <sup>3</sup> (3.7 L) 0.98 U.S.gals	
Coolant volume		3.1 dm <sup>3</sup> (3.1 L) 0.82 U.S.gals	
Hydraulic tank capacity		26.0 dm <sup>3</sup> (26.0 L) 6.87 U.S.gals	
Transmission oil capacity		-	
Operating width (Mowing width)		183 cm 72.05 in	
Operating height (Mowing height)		LH66 8.0 - 45.0 mm (*1) 0.315 - 1.772 in	
		LS66 10.0 - 46.0 mm 0.394 - 1.811 in	
Number of Blades		5, 7, 9	
Drive	Traveling		HST (2WD/3WD selectable)
	Mowing		Hydraulic (Gear motor drive)

# Product Overview

Speed (HST)	Forward	2WD	14.0 km/h	8.70 mph
		3WD	8.7 km/h	5.41 mph
	Reverse	2WD	10.0 km/h	6.22 mph
		3WD	6.2 km/h	3.85 mph
Speed (Mechanical)			-	
Efficiency			11,712 m <sup>2</sup> /h (8.0 km/h x mowing width x 0.8)	2.89 acres/hour (4.97 mph x mowing width x 0.8)
Maximum inclination for operation			15 degrees	
Tire size		Front wheel	20 x 12.00-10 4P	
		Rear wheel	20 x 8.00-10 4P	
Tire pneumatic pressure		Front wheel	140 kPa (1.4 kgf/cm <sup>2</sup> )	20 psi
		Rear wheel	140 kPa (1.4 kgf/cm <sup>2</sup> )	20 psi
Battery			75D23L	
Engine plug			-	

The factory default maximum engine rpm is 2,800 rpm.

(\*1) For 0.39 in (10 mm) or less mowing height, a bed knife with a thickness of 5 mm or less is required.

## Mower Units

Baroness mower unit that can fit this machine is the model marked with a circle in the "Attachable unit" column.  
LM331

Model		Attachable unit	Remarks
LH52	22 in	-	
LH62	22 in	-	
LH66	26 in	○	
LS60	30 in	-	
LS62	22 in	-	
LS66	26 in	○	
VM60	30 in	-	
VM62	22 in	-	
VM66	26 in	○	

## Sound Pressure Level

### Sound pressure level

This machine was confirmed to have a continuous A-weighted sound pressure level of 85 dB by measuring identical machines in accordance with the procedure specified in ISO5395-1:2013.

## Sound Power Level

### Sound Power Level

This machine was confirmed to have a sound power level of 103 dB by measuring identical machines in accordance with the procedure specified in ISO 5395-1:2013.

## Vibration Level

### Hand-Arm Vibration

This machine was confirmed not to exceed a vibration level of 2.5 m/s<sup>2</sup> to hands and arms by measuring identical machines in accordance with the procedure specified in ISO 5395-1:2013.

### Whole Body Vibration

This machine was confirmed not to exceed a vibration level of 0.5 m/s<sup>2</sup> to the whole body by measuring identical machines in accordance with the procedure specified in ISO 5395-1:2013.

## Carbon Dioxide (CO<sub>2</sub>) Emissions

For the CO<sub>2</sub> value on the engine of this machine, refer to the engine's owner's manual.

# Product Overview

## Names of Each Section

Overall View A

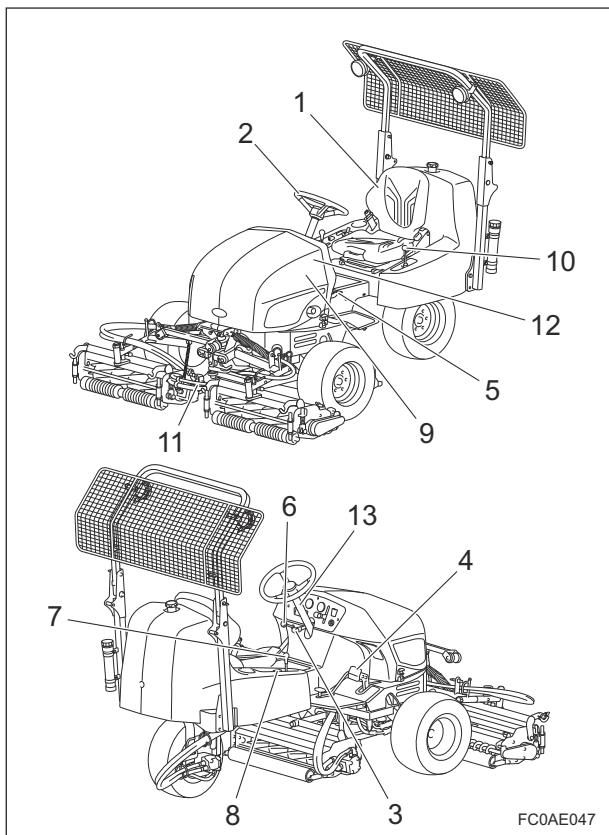

Names of Each Section\_001

1	Seat
2	Steering wheel
3	Tilt lever
4	Traveling pedal
5	Brake pedal
6	Parking brake lever
7	Mower unit up/down lever
8	Reel rotation switch
9	Reel reverse switch
10	2WD/3WD selector lever
11	Reel rotation/stop switching lever
12	Seat
13	Diff-lock switch

Overall View B

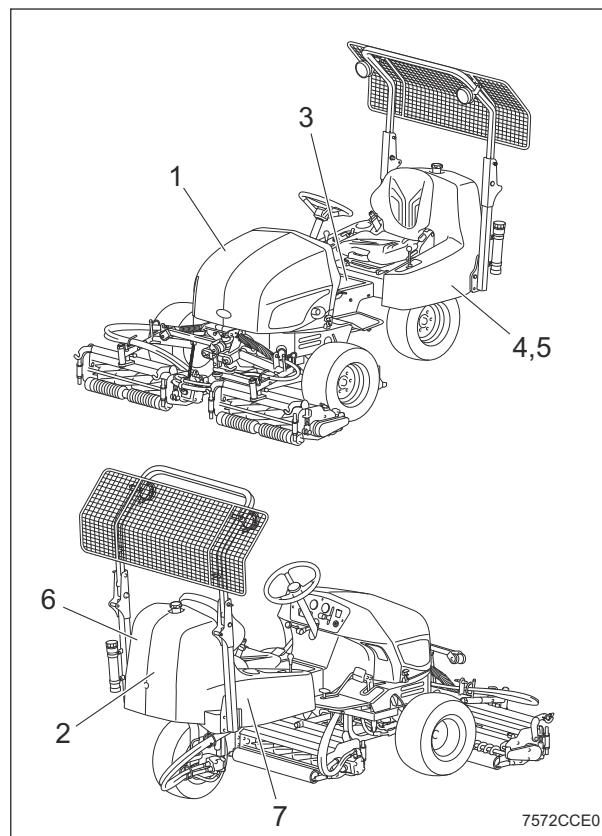

Names of Each Section\_002

1	Hood
2	Rear cover
3	Center cover
4	Battery
5	Battery cutoff switch
6	Fuel tank
7	Fuel filter

# Product Overview

Overall View C

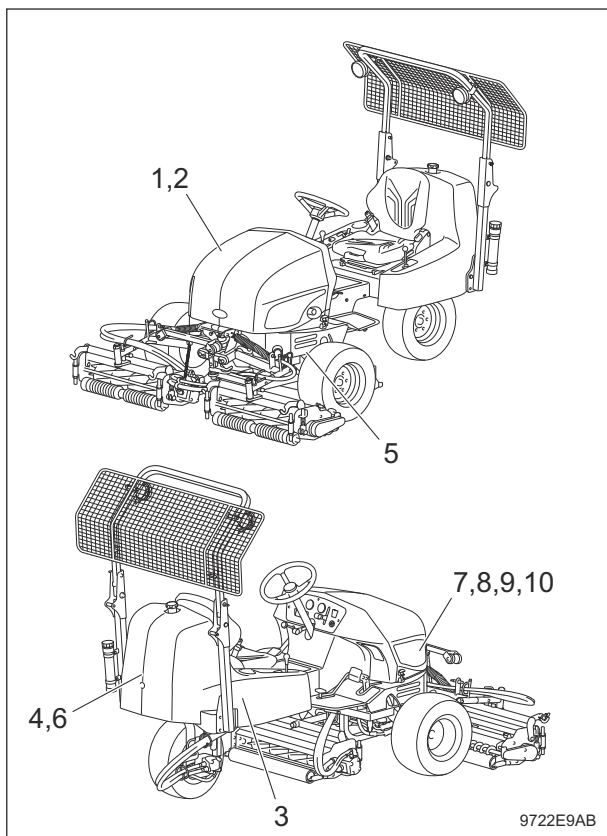

Names of Each Section\_003

1	Engine
2	Engine oil filter
3	Water separator
4	Hydraulic tank
5	Hydraulic oil line filter
6	Air breather
7	Radiator
8	Oil cooler
9	Reserve tank
10	Air cleaner

Overall View D

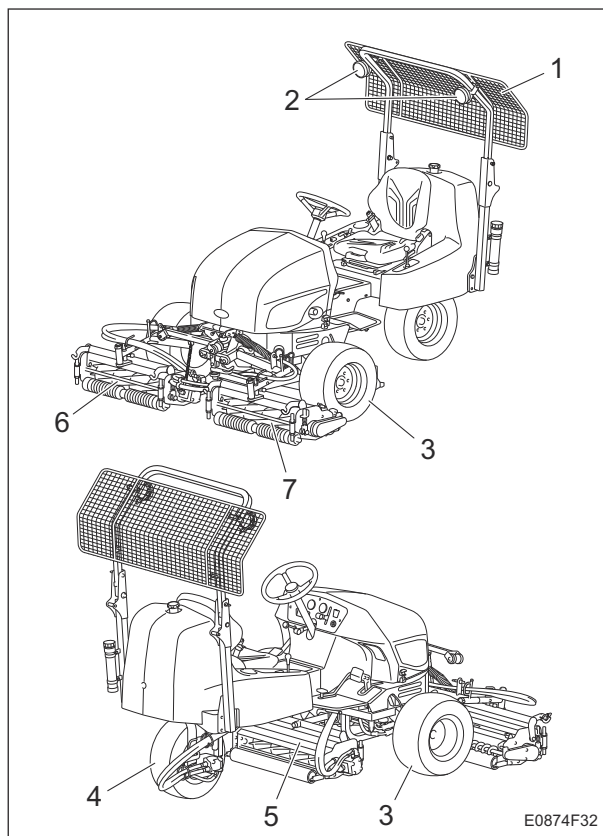

Names of Each Section\_004

1	Ball proof net
2	Light
3	Front tire
4	Rear tire
5	Mower unit #1
6	Mower unit #2
7	Mower unit #3

# Product Overview

---

Operation panel

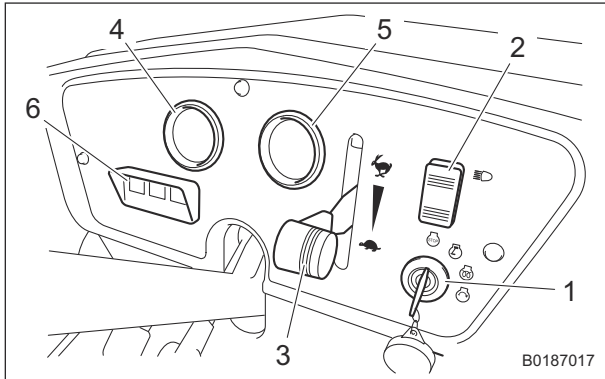

Names of Each Section\_005

1	Key switch
2	Light switch
3	Throttle lever
4	Water temperature gauge
5	Fuel gauge
6	Pilot lamp

## Regulation Decals

### Positions of Regulation Decals

#### Main vehicle

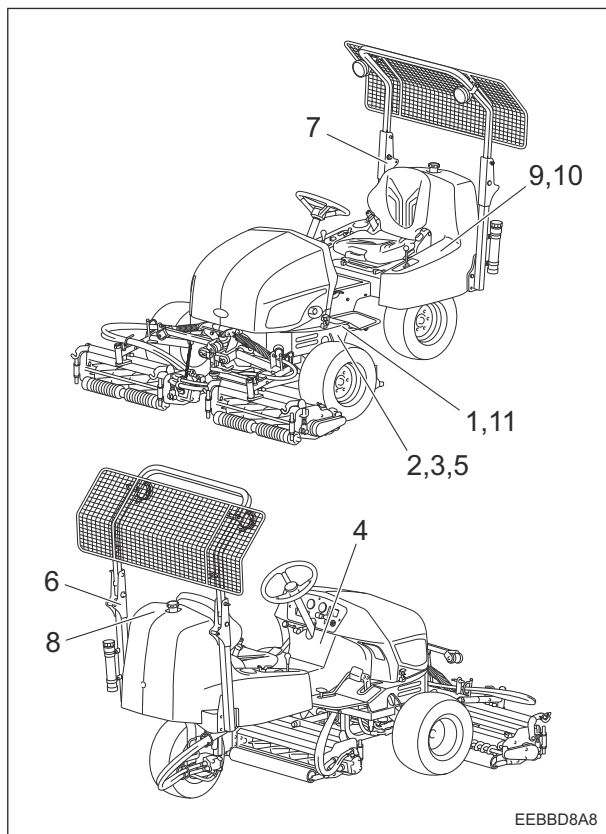

Positions of Regulation Decals\_001

1	Serial number plate
2	Specification decal
3	CE Mark
4	Noise emission decal
5	Year of manufacture decal
6	ROPS compliance decal
7	ROPS caution decal
8	Indicating diesel fuel decal
9	California Proposition65 decal (riding type)
10	Spark arrester warning decal
11	ISED compliance decal (#20089-)

#### Battery

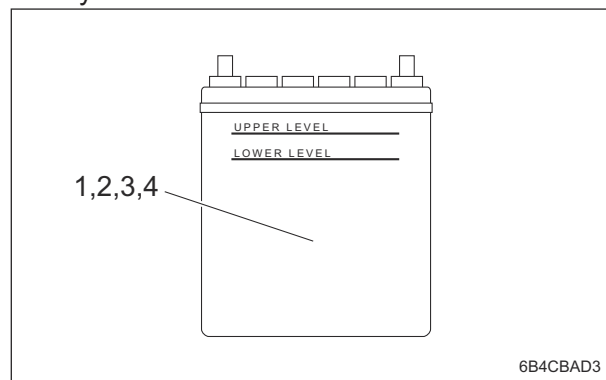

Positions of Regulation Decals\_002

1	Battery capacity decal
2	EU battery regulation decal
3	Recycle decal
4	Battery danger decal

### Description of Regulation Decals

#### Serial Number Plate

The following information is written on the serial number plate.

1. Model
2. Serial number
3. Registered trademark
4. Manufacturer

- Company name
- Postal address/Address
- Website

Contact the manufacturer via the contact form on the website.



Serial Number Plate\_001

# Product Overview

## Specification Decal

(For EU)  
The Specification decal indicates the model and weight, etc.

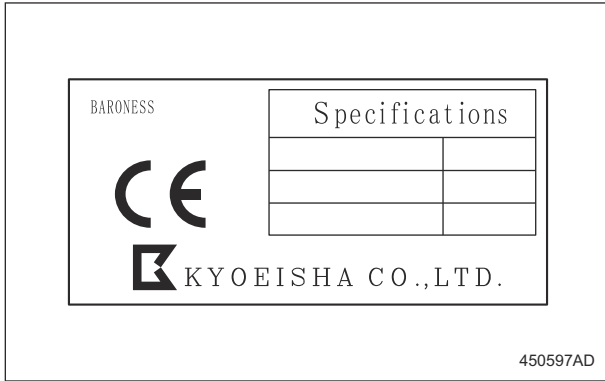

Specification Decal\_001

## CE Mark

(For EU)  
CE mark indicates that the machine sold in the EU nations complies with the EU requirements.

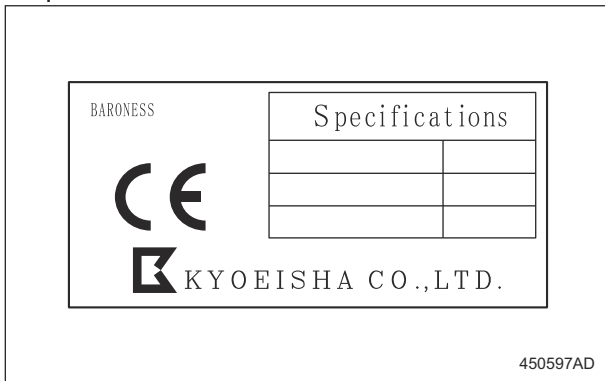

CE Mark\_001

## Noise Emission Decal

(For EU)  
The noise emission decal indicates the sound power level determined by measuring identical machines in accordance with the procedure specified in the regulations of EU.

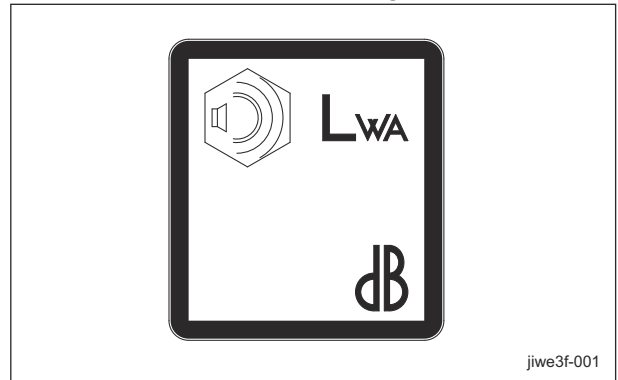

Noise Emission Decal\_001

## Year of Manufacture Decal

(For EU)  
The year of manufacture decal indicates the year when this machine was manufactured.

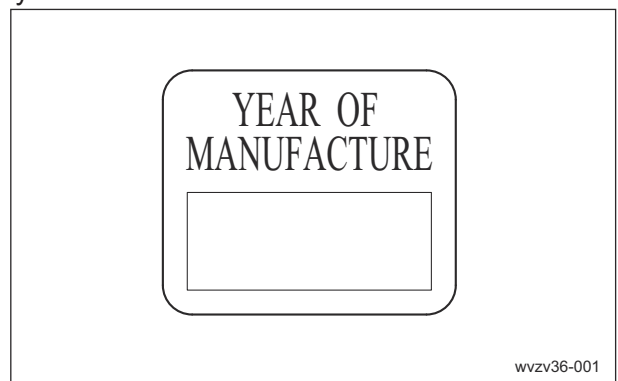

Year of Manufacture Decal\_001

## ROPS Compliance Decal

The ROPS compliance decal indicates the manufacturer, model, etc., in accordance with International Standard ISO 21299:2009.

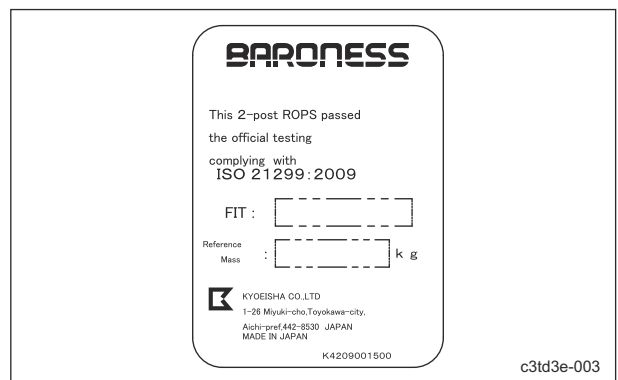

ROPS Compliance Decal\_001

## ROPS Caution Decal

ROPS caution decal describes the following caution messages.

- Replace damaged ROPS.
- Do not repair or revise.

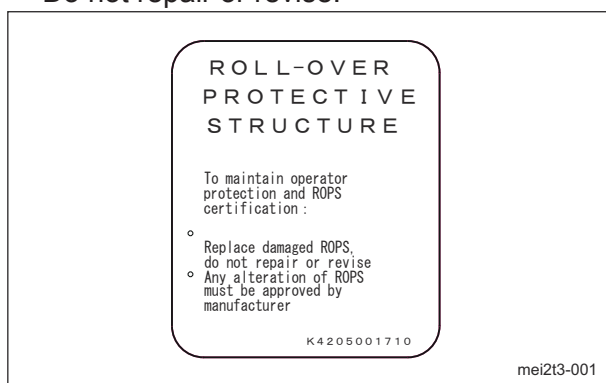

ROPS Caution Decal\_001

## California Proposition 65 Decal (Riding Type)

(For the State of California, USA)

California Proposition 65 decal describes the warning messages as required by California Proposition 65.

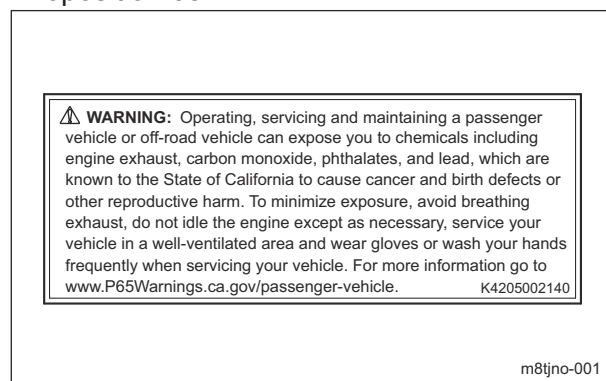

California Proposition 65 Decal (Riding Type)\_001

## Indicating Diesel Fuel Decal

(for USA)

It indicates the fuel to be used.

Use low sulfur or ultra-low sulfur diesel fuel (sulfur-free diesel fuel).

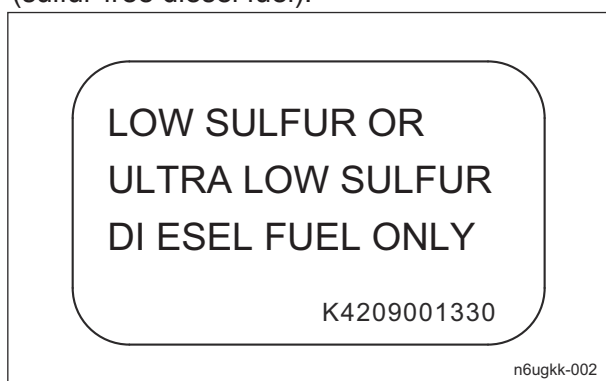

Indicating Diesel Fuel Decal\_001

## Spark Arrester Warning Decal

(For the State of California, USA)

Spark arrester warning decal describes the warning messages as required by California Public Resources Code.

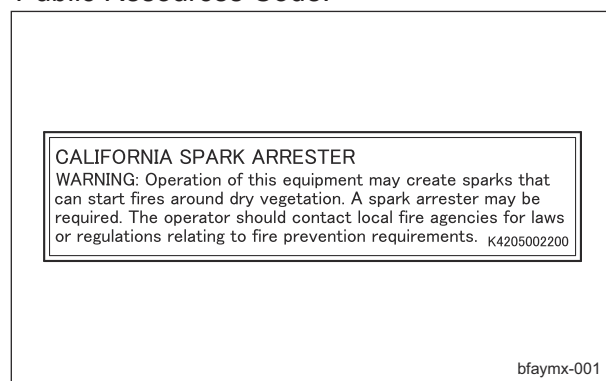

Spark Arrester Warning Decal\_001

# Product Overview

## ISED Compliance Decal

(For Canada)

The ISED compliance decal indicates that the product marketed in Canada meets Canadian standard.

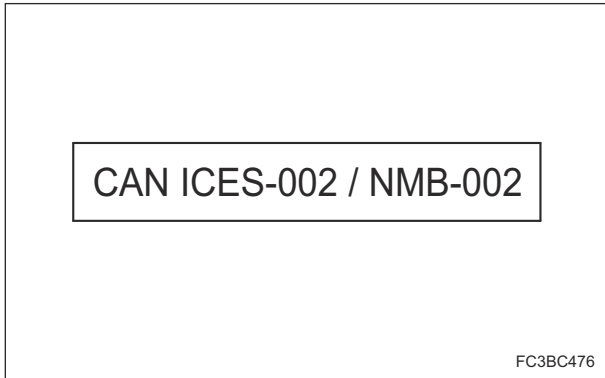

ISED Compliance Decal\_001

## Battery Capacity Decal

(For EU)

The battery capacity decal indicates the capacity by 20HR and CCA.

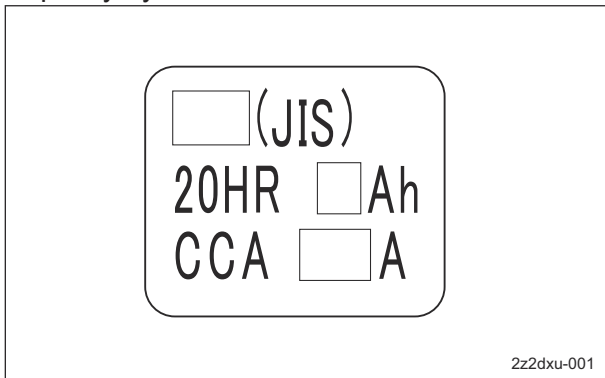

Battery Capacity Decal\_001

## EU Battery Regulation Decal

(For EU)

The EU battery regulation decal indicates compliance with the EU battery regulation.

- The following information about the battery manufacturing company is written in the decal.
  - Company name
  - Address
  - Website URL
- You can scan the QR code with your smartphone to access the corresponding battery information.  
(\*QR Code is a registered trademark of DENSO WAVE INCORPORATED.)
- CE mark indicates that the battery installed in a machine sold in the EU nations complies with the EU requirements.

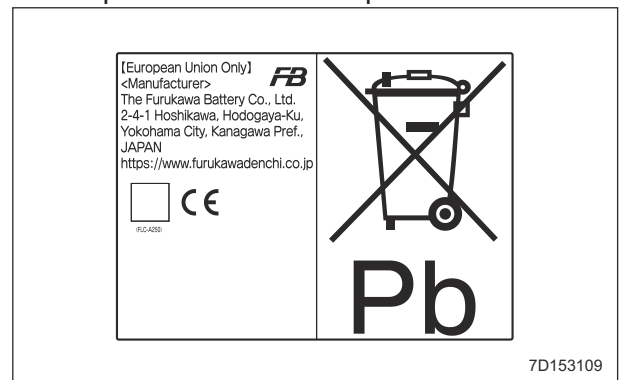

EU Battery Regulation Decal\_001

## Recycle Decal

Recycle Decal illustrates Recycle Mark in accordance with local regulation.

(For EU)

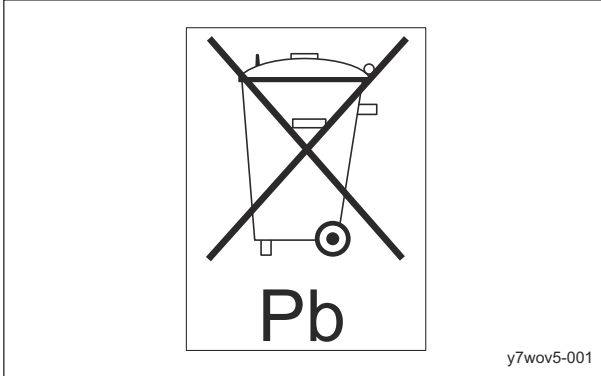

Recycle Decal\_001

(For USA)



Recycle Decal\_002

## Battery Danger Decal

(For USA)

Battery Danger Decal describes handling precautions for battery.

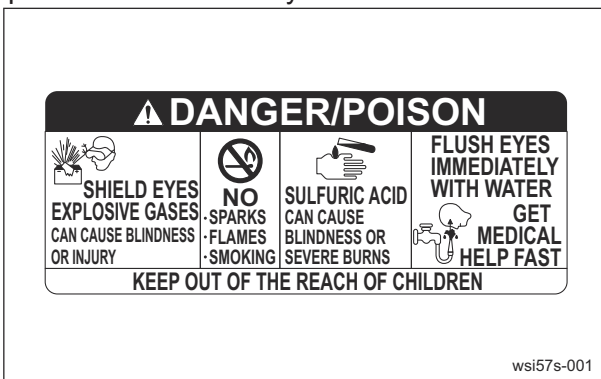

Battery Danger Decal\_001

# Product Overview

## Safety Signs and Instruction Signs

### About Safety Signs and Instruction Signs

**Important**

Safety decals and instruction decals are attached to this product. Make sure that they are preserved in their entirety. If they are damaged, become dirty, or peel off, replace them with new ones.

Part numbers for decals that need to be replaced are listed in the parts catalog. Order them from a Baroness dealer or Kyoisha.

### Positions of Safety Decals and Instruction Decals

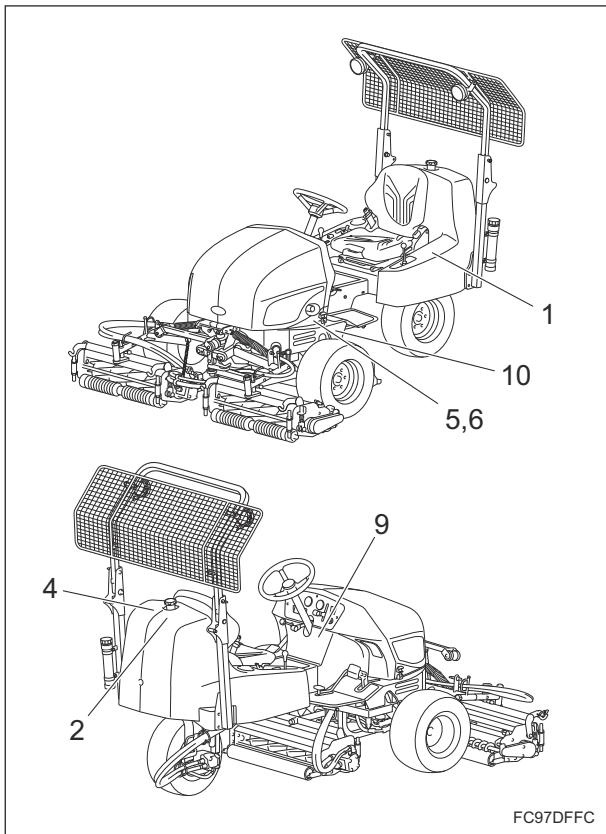

Positions of Safety Decals and Instruction Decals\_001

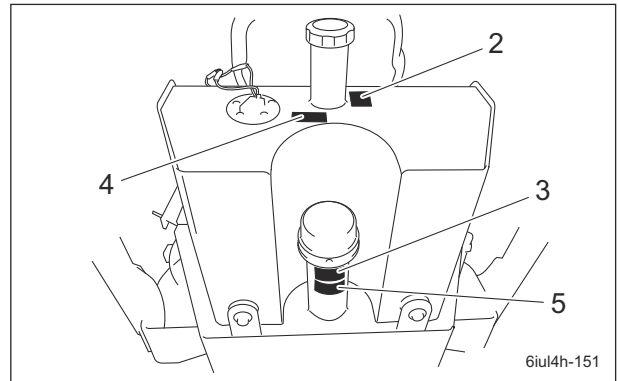

Positions of Safety Decals and Instruction Decals\_002

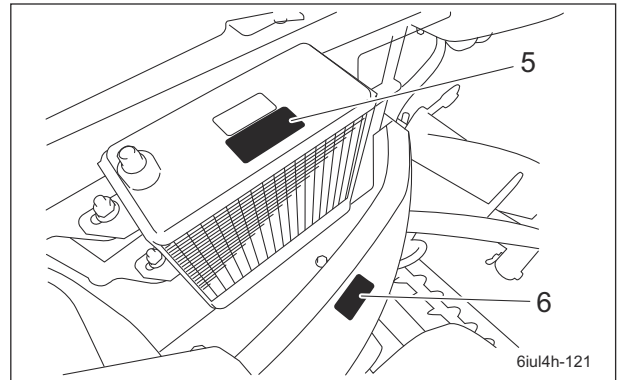

Positions of Safety Decals and Instruction Decals\_003

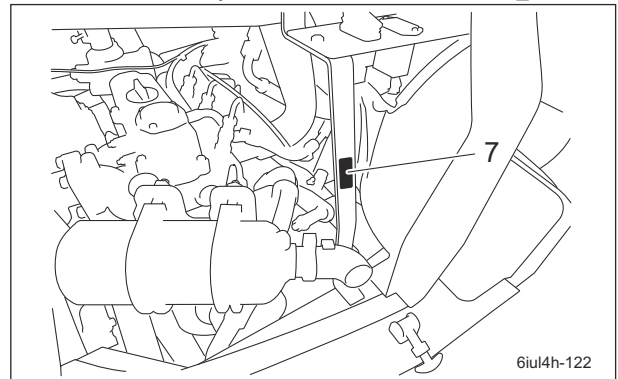

Positions of Safety Decals and Instruction Decals\_004

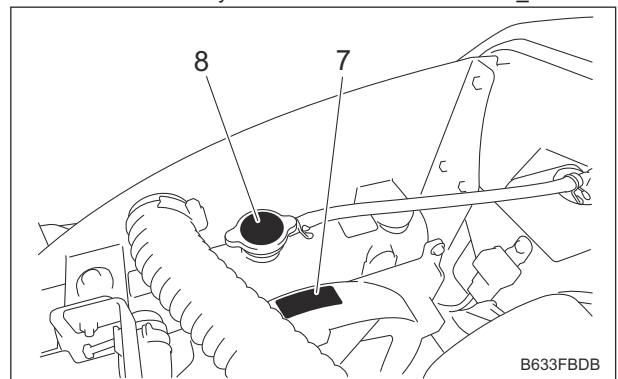

Positions of Safety Decals and Instruction Decals\_005

1	Left panel decal
2	Diesel fuel filler port decal
3	Hydraulic oil decal
4	Fire prohibited decal
5	Caution for high temperatures decal
6	Caution for getting pinched decal
7	Caution for getting entangled decal
8	Caution for spouting coolant decal
9	Caution to noise decal
10	Molybdenum grease decal

# Product Overview

## Description of Safety Decals and Instruction Decals

### Left Panel Decal

LM331--0928Z0  
Decal, left panel

1.



Warning

Read the Owner's Operating Manual.

2.



Warning

Apply the parking brake, stop the engine, and then remove the ignition key before leaving the machine.

3.



Caution

Thrown objects - Be sure that people around the machine keep a safe distance away.

4.

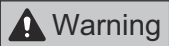

Warning

May cut your hand or leg - Keep hands and feet away from moving parts.

5.

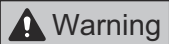

Warning

Be careful of exhaust emissions.

6.



Caution

Rollover - Do not work on slopes of 15 degrees or more.  
When you descend a slope, drive at low speed with the mower units lowered.  
Fasten your seatbelt.

7.

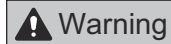

Warning

Rollover - Do not switch between 2WD and 3WD while traveling on downward slopes.  
Do not set the reel rotation switch to the "Rotation" (reel rotation) position while traveling on downward slopes.  
Do not travel in three-wheel drive on downward slopes.

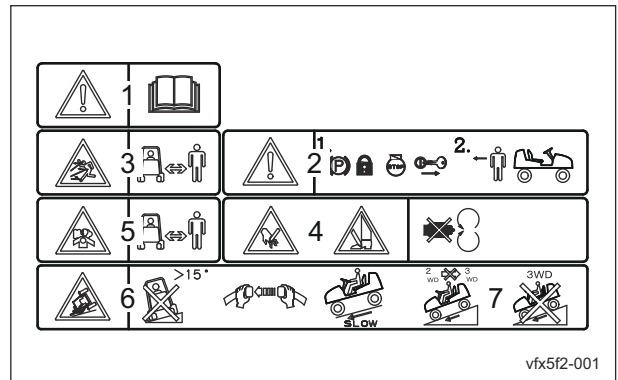

vfx5f2-001

Left Panel Decal\_001

## Diesel Fuel Filler Port Decal

K4209001000  
 DECAL, DIESEL OIL FILLER PORT  
 Use diesel fuel.

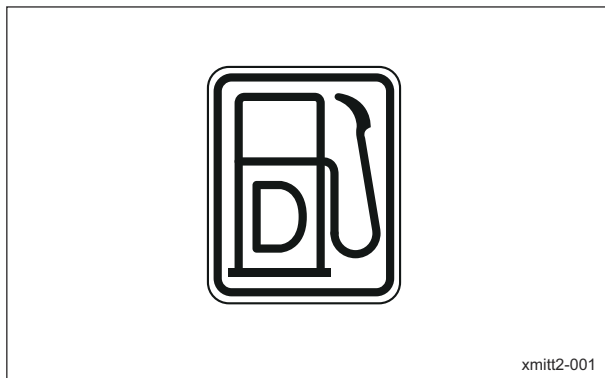

Diesel Fuel Filler Port Decal\_001

## Hydraulic Oil Decal

K4209001390  
 Decal, hydraulic oil  
 Read the owner's operating manual.

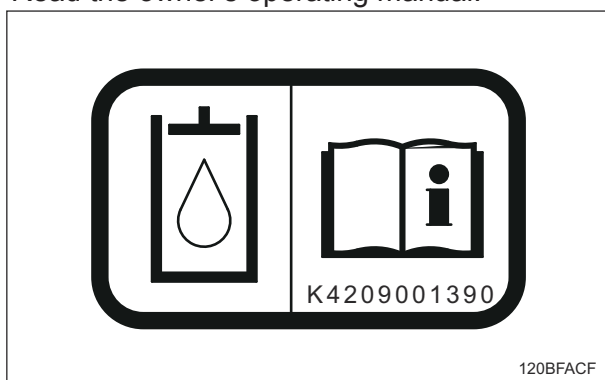

Hydraulic Oil Decal\_001

## Fire Prohibited Decal

K4205001940  
 Decal, fire prohibited

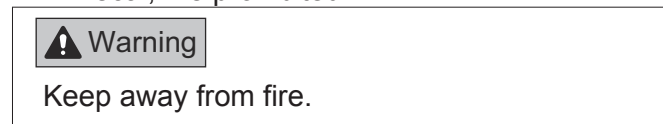

Fire Prohibited Decal\_001

## Caution for High Temperatures Decal

K4205001920  
 Decal, caution for high temperatures

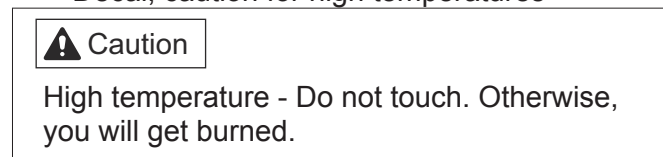

Caution for High Temperatures Decal\_001

# Product Overview

## Caution for Getting Pinched Decal

K4205001930  
 DECAL, CAUTION GETTING CAUGHT  
 HANDS/FEET

**Caution**

May get pinched - There is a risk of being pinched.

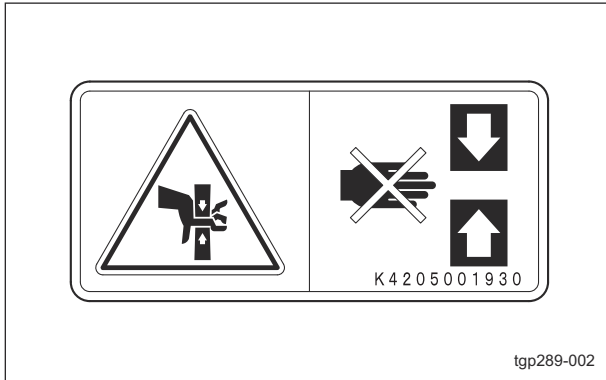

tgp289-002

Caution for Getting Pinched Decal\_001

## Caution for Getting Entangled Decal

K4205001910  
 DECAL, CAUTION NOT TO GET CAUGHT  
 IN

**Warning**

Watch for rotating parts - Keep your hands away from the belts while the engine is running.

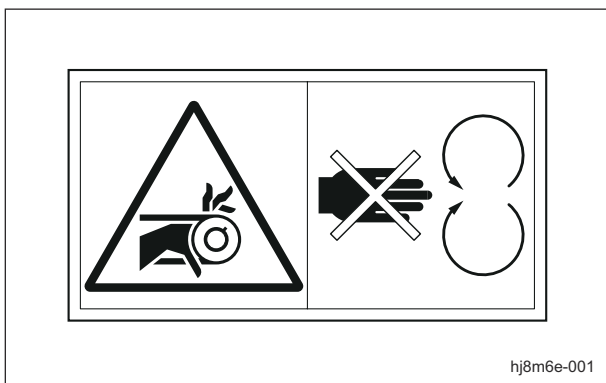

hj8m6e-001

Caution for Getting Entangled Decal\_001

## Caution for Spouting Coolant Decal

K4205001970  
 Decal, caution for spouting coolant

**Caution**

Caution for spouting coolant - Do not open while hot.  
 High temperature - Do not touch. Otherwise, you will get burned.

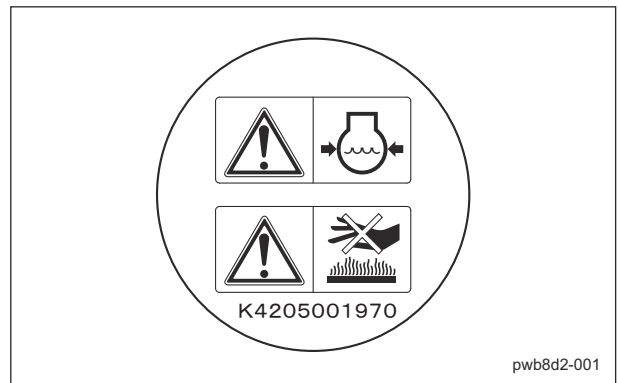

pwb8d2-001

Caution for Spouting Coolant Decal\_001

## Caution to Noise Decal

K4205002090  
 Decal, caution to noise

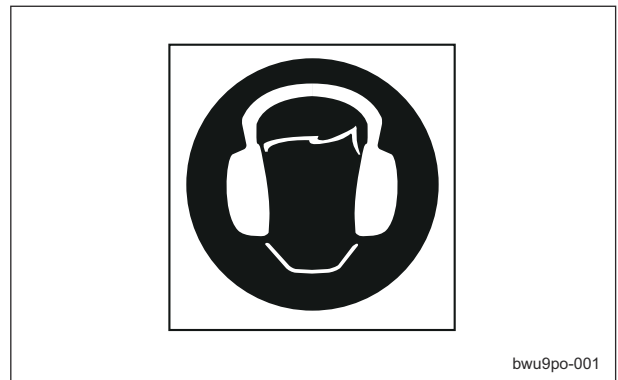

bwu9po-001

Caution to Noise Decal\_001

## Molybdenum Grease Decal

K4209002020  
DECAL, GREASE  
Add Moly speed grease No.2.

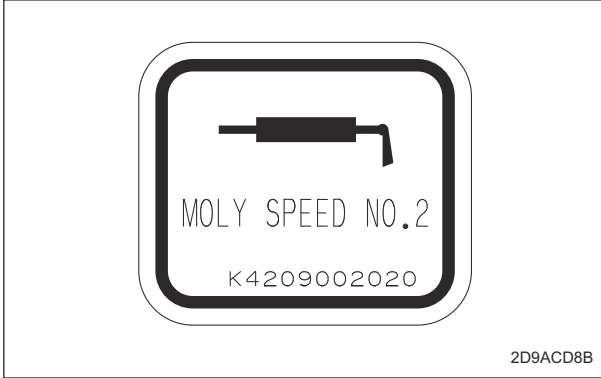

Molybdenum Grease Decal\_001

# Product Overview

## Operation Decals

### Positions of Operation Decals

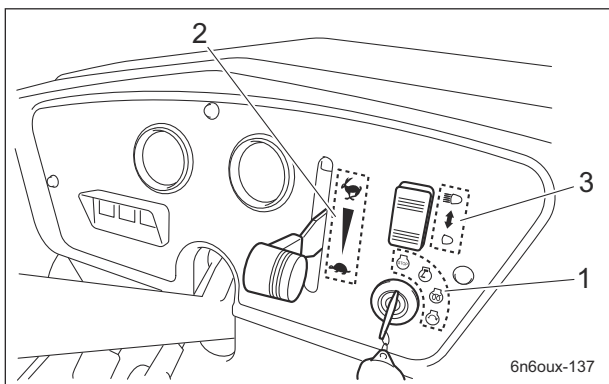

Positions of Operation Decals\_001

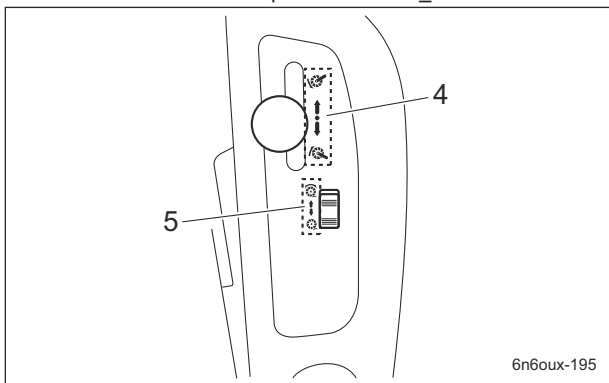

Positions of Operation Decals\_002

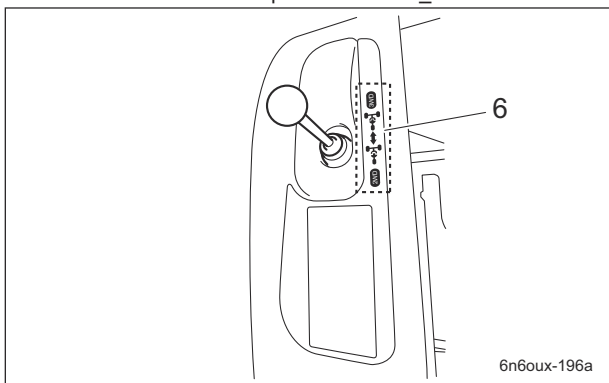

Positions of Operation Decals\_003

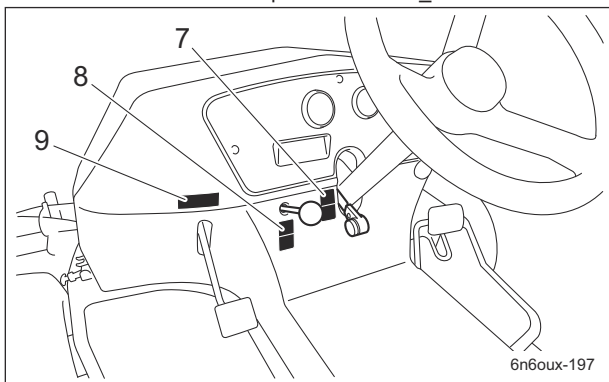

Positions of Operation Decals\_004

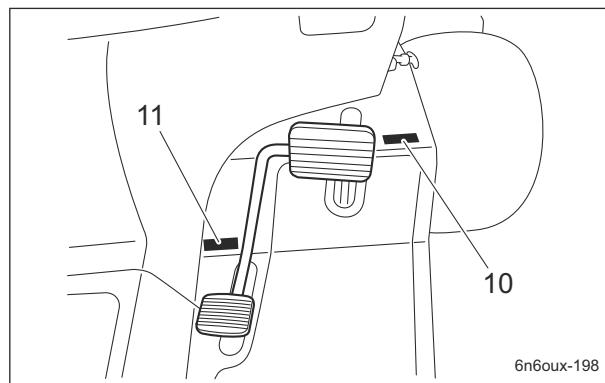

Positions of Operation Decals\_005

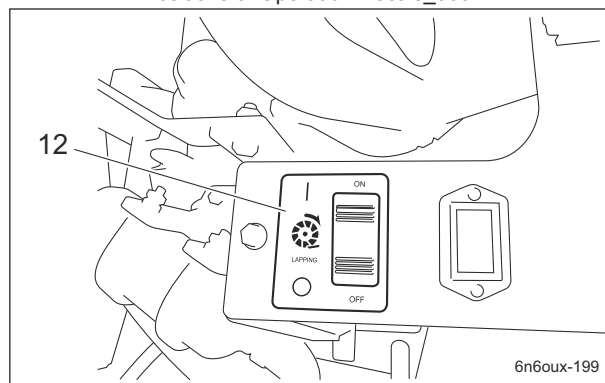

Positions of Operation Decals\_006

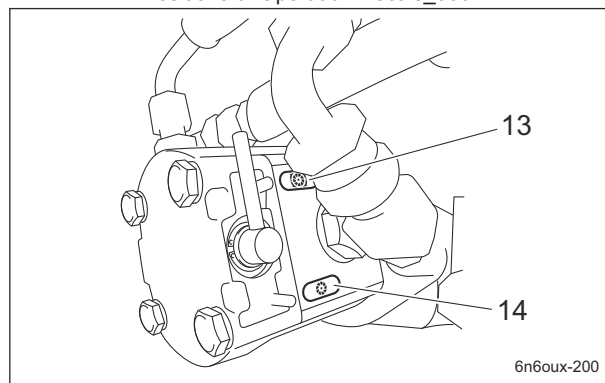

Positions of Operation Decals\_007

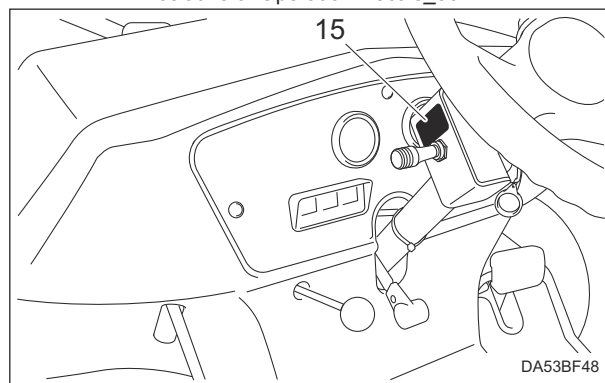

Positions of Operation Decals\_008

1	Key switch decal
2	Engine rotation decal
3	Light switch decal
4	Mower unit up/down decal
5	Reel rotation decal
6	2WD - 3WD selector lever decal
7	Tilt steering decal
8	Parking brake decal
9	BRAKE decal
10	FORWARD decal
11	BACKWARD decal
12	Lapping switch decal
13	Reel rotation decal
14	Reel stop decal
15	Differential lock decal

# Product Overview

## Description of Operation Decals

### Key Switch Mark

Key switch mark

This indicates the key switch positions.

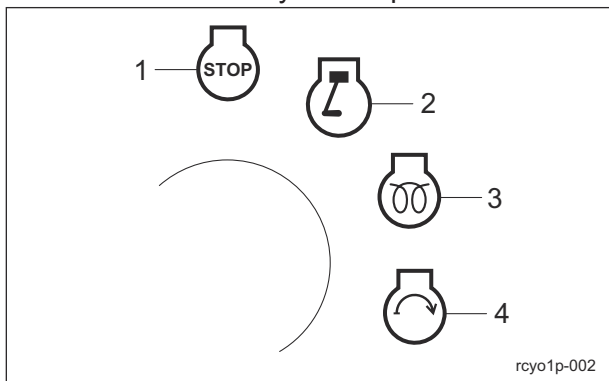

Key Switch Mark\_001

1	OFF
2	ON
3	GLOW
4	START

### Engine Rotation Mark

Engine Rotation mark

This indicates high/low speed of the engine rotation.

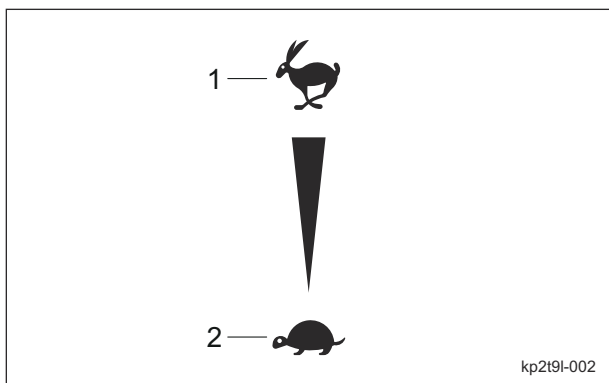

Engine Rotation Mark\_001

1	High speed
2	Low speed

### Light Switch Decal

Note:

Depending on the specifications, this function may not be available.

LM331--1105Z0

Light switch decal

This indicates the light switch positions.

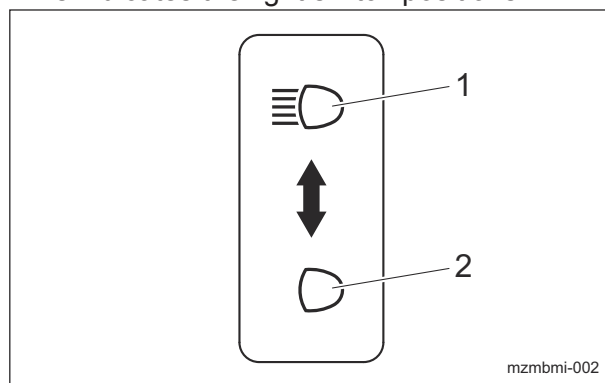

Light Switch Decal\_001

1	ON
2	OFF

### Mower Unit Up/Down Decal

Decal, mower unit up/down

This indicates the Up/Down positions of the mower unit.

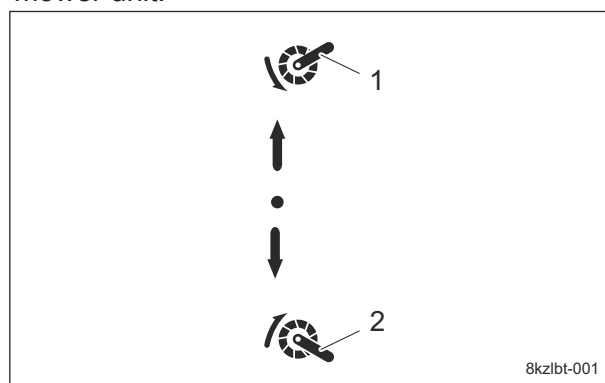

Mower Unit Up/Down Decal\_001

1	Down
2	Up

## Reel Rotation Mark

Reel rotation mark  
It illustrates Rotation/Stop of the reel cutter (cutting cylinder).

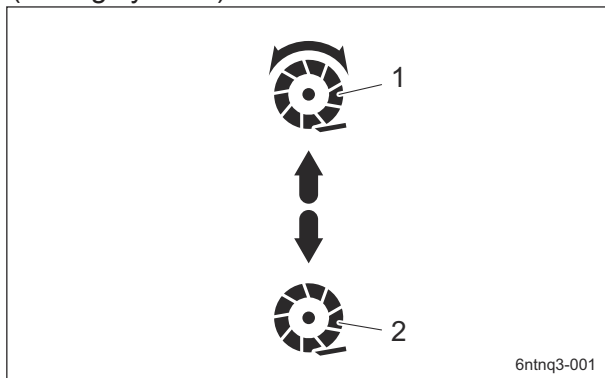

Reel Rotation Mark\_001

1	Rotation
2	Stop

## 2WD - 3WD selector lever decal

2WD - 3WD selector lever decal  
This indicates the 2WD/3WD positions.

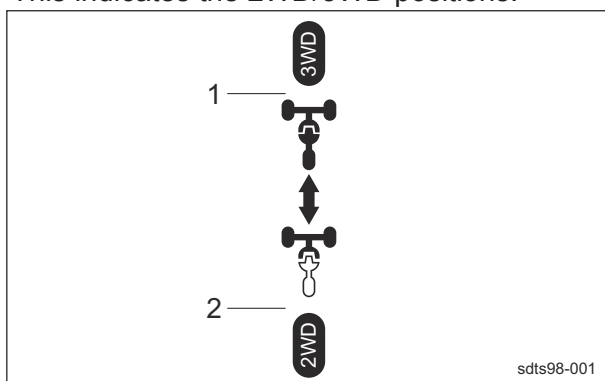

2WD - 3WD selector lever decal\_001

1	3WD
2	2WD

## Tilt Steering Decal

K4203001500  
Tilt steering decal  
This illustrates the tilt directions of the steering wheel and the locked/free positions.

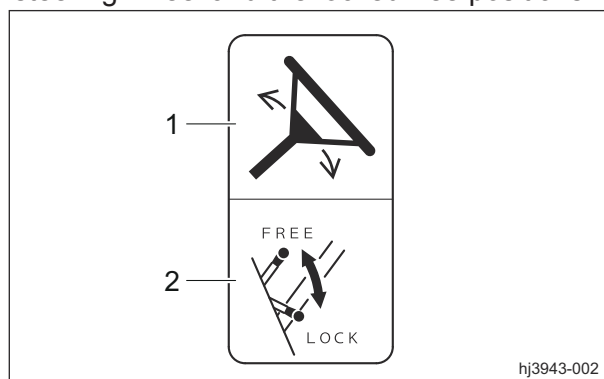

Tilt Steering Decal\_001

## Parking Brake Decal

K4203001340  
Parking brake decal  
This shows how to lock and release the parking brake.

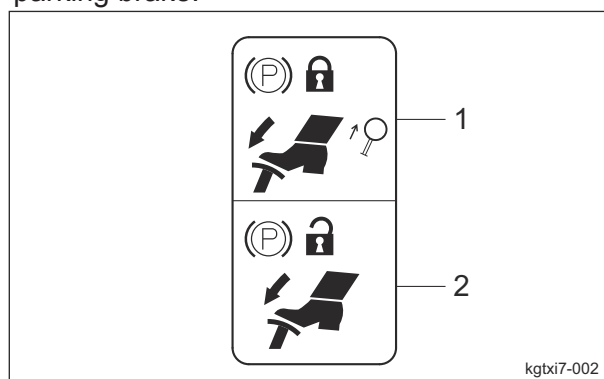

Parking Brake Decal\_001

1	Lock
2	Release

# Product Overview

## BRAKE Decal

K4203001450  
Decal, BRAKE  
This indicates brake.



BRAKE Decal\_001

## FORWARD Decal

K4203001430  
Decal, FORWARD  
This indicates forward travel.



FORWARD Decal\_001

## BACKWARD Decal

K4203001440  
Decal, BACKWARD  
This indicates backward travel.

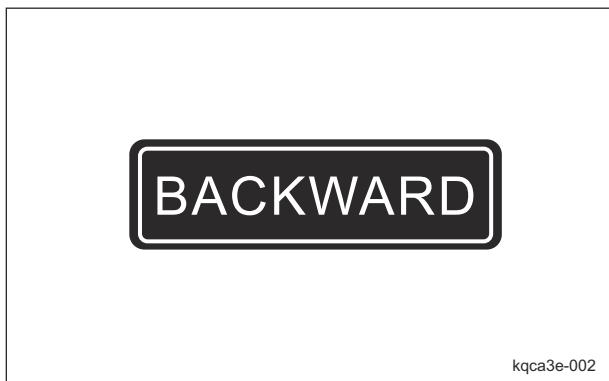

BACKWARD Decal\_001

## Lapping Switch Decal

LM331--0556Z0  
Lapping switch decal  
This indicates the ON/OFF positions for back lapping.

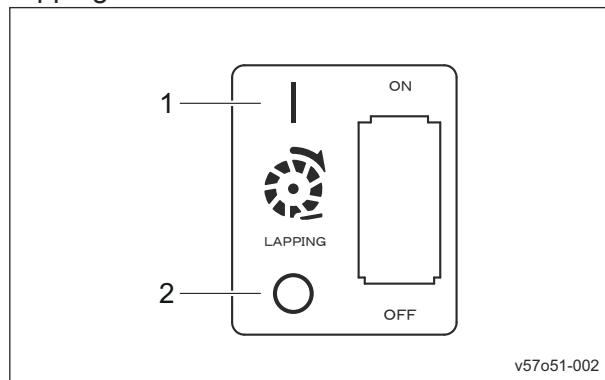

Lapping Switch Decal\_001

1	ON (back lapping rotation)
2	OFF (mowing rotation)

## Reel Rotation Decal

K4203001300  
Decal, reel rotation  
This indicates rotation of the reel cutter (cutting cylinder).

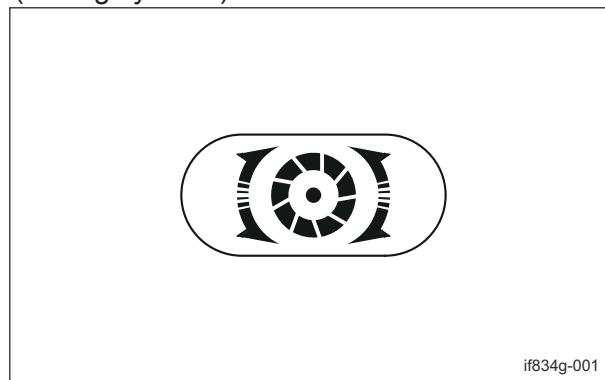

Reel Rotation Decal\_001

## Reel Stop Decal

K4203001310

Decal, reel stop

This indicates stop of the reel cutter (cutting cylinder).

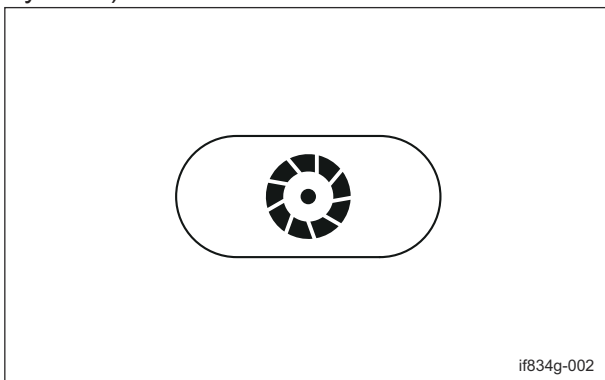

Reel Stop Decal\_001

## Differential Lock Decal

K4203001420

Decal, differential lock

This indicates the positions for engaging or releasing the differential lock.

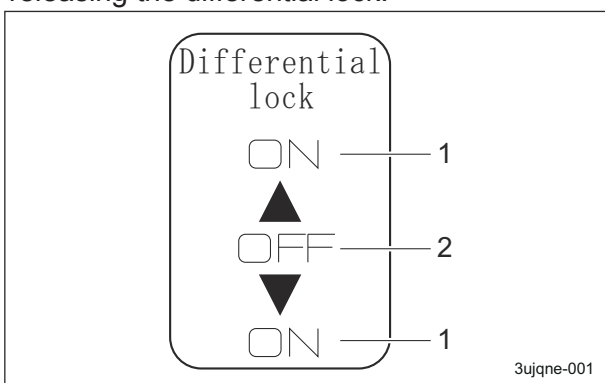

Differential Lock Decal\_001

1	Engage
2	Release

# Product Overview

---

# Description of Functions

---

<b>Proximity Sensor .....</b>	<b>Page 4-2</b>
<b>2WD/3WD Selector Lever .....</b>	<b>Page 4-2</b>
<b>Key Switch .....</b>	<b>Page 4-2</b>
<b>Light Switch .....</b>	<b>Page 4-3</b>
<b>Diff-Lock Switch .....</b>	<b>Page 4-3</b>
<b>Throttle Lever .....</b>	<b>Page 4-3</b>
<b>Mower Unit Up/Down Lever .....</b>	<b>Page 4-4</b>
<b>Reel Rotation Switch .....</b>	<b>Page 4-4</b>
<b>Reel Reverse Switch .....</b>	<b>Page 4-5</b>
<b>Reel Rotation/Stop Switching Lever ....</b>	<b>Page 4-5</b>
<b>Traveling Pedal .....</b>	<b>Page 4-5</b>
<b>Brake Pedal .....</b>	<b>Page 4-6</b>
<b>Parking Brake Lever .....</b>	<b>Page 4-6</b>
<b>Battery Cutoff Switch .....</b>	<b>Page 4-6</b>
<b>Instruments in the Meter Panel .....</b>	<b>Page 4-7</b>
Water Temperature Gauge .....	Page 4-7
Fuel Gauge .....	Page 4-7
Pilot Lamps .....	Page 4-7
Hour Meter .....	Page 4-8
<b>Safety Device .....</b>	<b>Page 4-8</b>
Interlock System .....	Page 4-8
<b>Warning Mechanisms .....</b>	<b>Page 4-9</b>
Warning Buzzer .....	Page 4-9

# Description of Functions

## Proximity Sensor

There is a proximity sensor on #2 mower arm fulcrum.

This sensor detects the raised or lowered positions of mower unit #2. The information is related to controlling rotation and stop of the reel cutter (cutting cylinder).

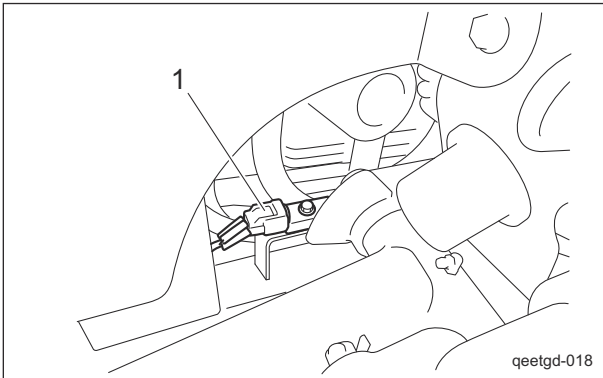

Proximity Sensor\_001

1	Proximity sensor
---	------------------

## 2WD/3WD Selector Lever

### Caution

Since traveling on steep downward slopes, wet surfaces and wet grassy downward slopes in 3WD is dangerous, use 2WD. Otherwise, the rear tire may slip and travel control may be lost.

### Important

Before switching between 2WD and 3WD operation, make sure that the machine is completely stopped. Otherwise, the hydraulic equipments will malfunction.

The 2WD/3WD selector lever is located to the left of the driver's seat. When the lever is shifted forward, 3WD mode is selected. When the lever is shifted backward, 2WD mode is selected.

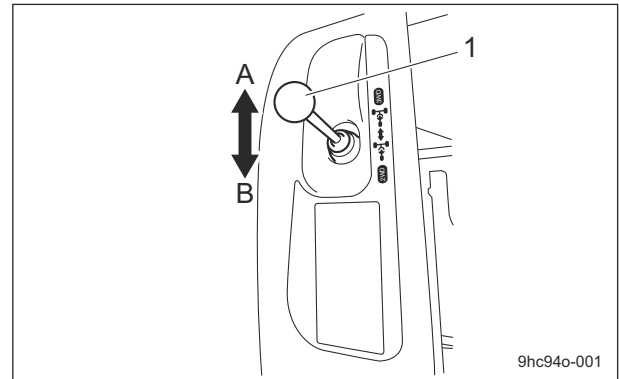

2WD/3WD Selector Lever\_001

1	2WD/3WD selector lever
A	3WD
B	2WD

## Key Switch

The key switch is a lock for inserting the ignition key.

This is used for starting, running or stopping the engine by turning the ignition key to change the key switch position.

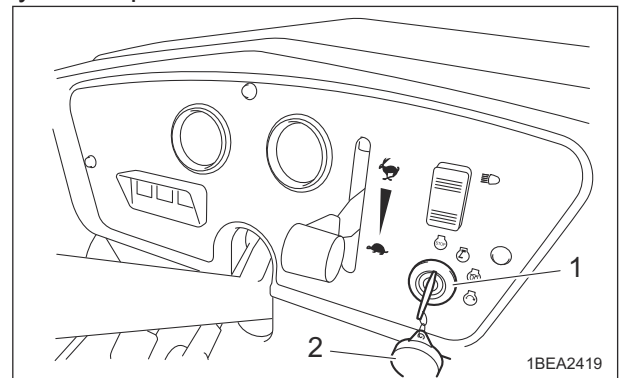

Key Switch\_001

1	Key switch
2	Cap

# Description of Functions

## Light Switch

### Caution

The lights provide auxiliary lighting. Do not travel or operate the machine at night or under poor visibility.

### Note:

Depending on the specifications, this function may not be available.

The light switch is located in the meter panel. When the switch is set to the "ON" position, the lights turn on. When it is set to the "OFF" position, the lights turn off.

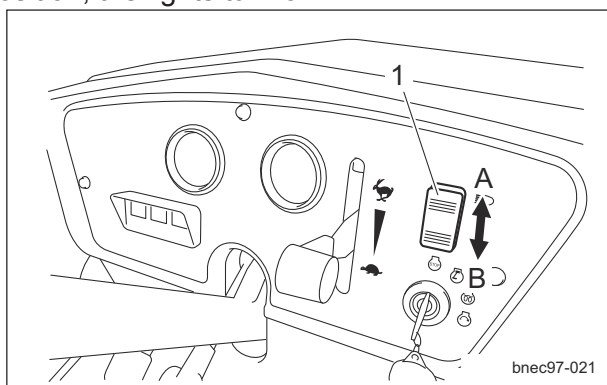

Light Switch\_001

1	Light switch
A	ON
B	OFF

### Note:

The lights will not turn on when the key switch is set to the "OFF" position.

## Diff-Lock Switch

### Important

Do not operate the diff-lock switch unless it is necessary.

The diff-lock switch engages the differential lock for the left and right front wheels.

Tilt the switch lever up or down to turn "ON" to engage the differential lock for the front wheels. Release the switch lever to return it to the neutral position ("OFF" position) and disengage the differential lock.

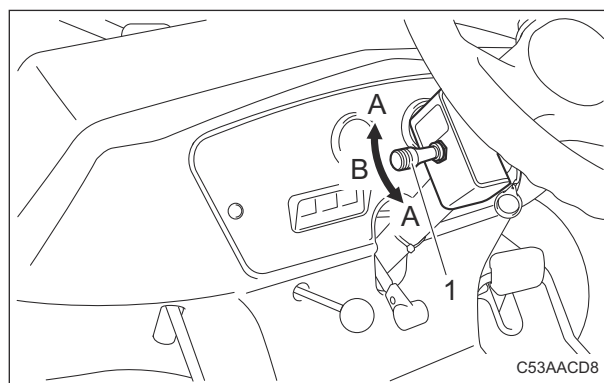

Diff-Lock Switch\_001

1	Diff-lock switch
A	ON (Lock)
B	OFF (Release)

## Throttle Lever

The throttle lever is located in the meter panel and enables you to adjust the engine rpm. Move the throttle lever toward the "High speed" position to increase the engine rpm, and toward the "Low speed" position to reduce the rpm.

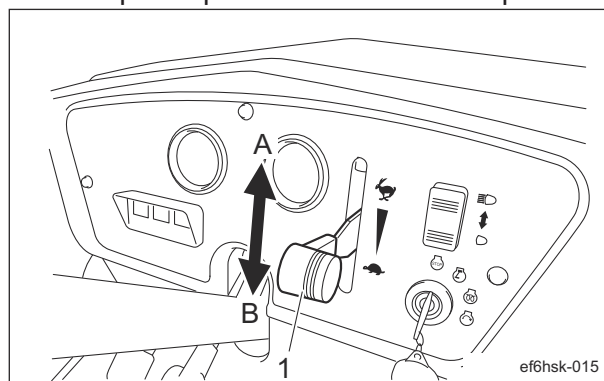

Throttle Lever\_001

1	Throttle lever
A	High speed
B	Low speed

# Description of Functions

## Mower Unit Up/Down Lever

**Caution**  
Before raising or lowering the mower units, be sure to sit on the seat.

**Caution**  
Before raising or lowering the mower units, make sure that there are no people around the machine.

**Caution**  
Be careful since shifting the mower unit up/down lever to the "DOWN" position lowers the mowers, even while the engine is stopped.

The mower unit up/down lever is located in the operation panel (to the right of the driver's seat) and raises or lowers the mower units. Shift the lever to the "DOWN" position to lower the mower units, and shift it to the "UP" position to raise the mower units.

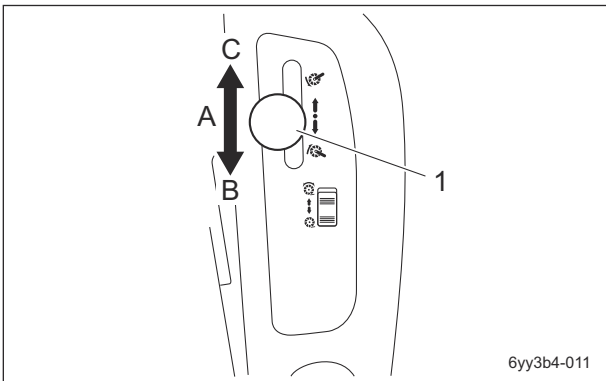

Mower Unit Up/Down Lever\_001

1	Mower unit up/down lever
A	Neutral
B	Up
C	Down

**Note:**

Even if the reel rotation switch is set to the "Rotation" position, the reel cutter (cutting cylinder) stops rotating when the mower units are raised.

## Reel Rotation Switch

**Caution**  
Set the reel rotation switch to the "Rotation" position immediately before starting cutting work or back lapping. At all other times, be sure to leave the reel rotation switch set to the "Stop" position.

The reel rotation switch is located in the operation panel (to the right of the driver's seat) and operates rotation of the reel cutters (cutting cylinders) of the mower units.

When the reel rotation switch is set to the "Rotation" position, the reel cutters (cutting cylinders) of all mower units will rotate. When the reel rotation switch is set to the "Stop" position, the reel cutters (cutting cylinders) will stop.

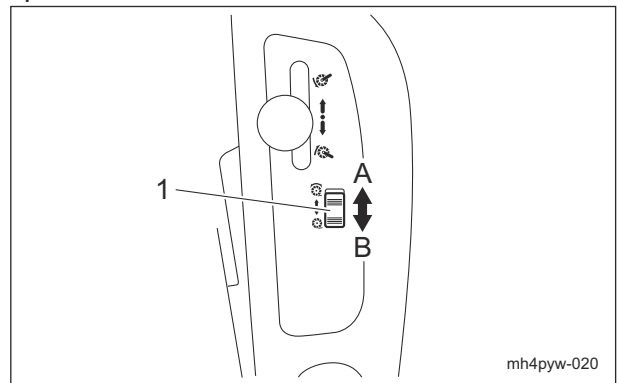

Reel Rotation Switch\_001

1	Reel rotation switch
A	Rotation
B	Stop

# Description of Functions

## Reel Reverse Switch

**Important**

Do not switch the reel reverse switch to the "ON" or "OFF" position while the reel cutter (cutting cylinder) is rotating. Otherwise, a hydraulic system malfunction will occur.

**Important**

If the reel rotation switch is not set to the "Rotation" position, the reel cutter (cutting cylinder) will not rotate.

The reel reverse switch is located under the hood. This switches the rotation direction of the reel cutter (cutting cylinder). When the reel reverse switch is set to the "ON" position, the reel cutters (cutting cylinders) of all mower units rotate in reverse (back lapping rotation). When the reel reverse switch is set to the "OFF" position, the reel cutters (cutting cylinders) rotate normally.

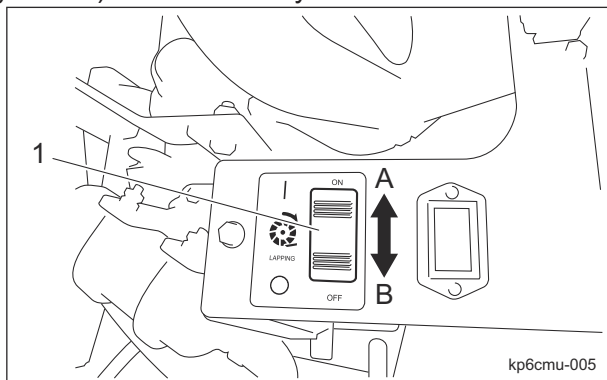

Reel Reverse Switch\_001

1	Reel reverse switch
A	ON (reverse rotation)
B	OFF (normal rotation)

## Reel Rotation/Stop Switching Lever

**Caution**

Before operating the reel rotation/stop switching lever, be sure to set the reel rotation switch to the "Stop" position.

The reel rotation/stop switching lever is located on the reel motor attached to each mower unit. It is used during cutting and back lapping. Shift the lever(s) to the "Rotation" position only for the mower unit(s) to be used for cutting or back lapping. Leave the lever(s) for other mower units in the "Stop" position.

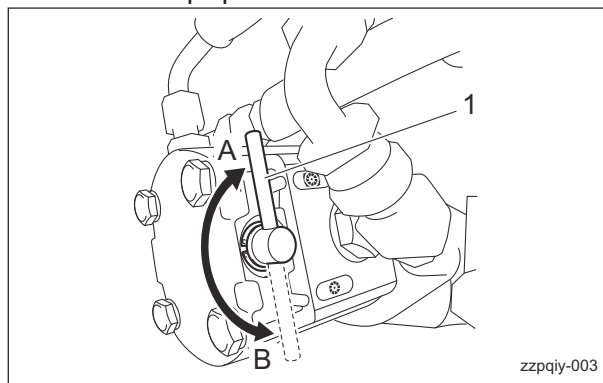

Reel Rotation/Stop Switching Lever\_001

1	Reel rotation/stop switching lever
A	Rotation
B	Stop

## Traveling Pedal

The traveling pedal is located in the right foot area.

When the forward end is depressed, the machine travels forward. When the backward end is depressed, the machine travels backward.

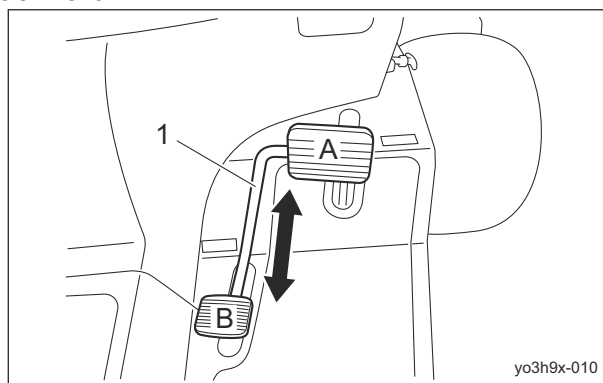

Traveling Pedal\_001

# Description of Functions

1	Traveling pedal
A	Forward
B	Backward

## Brake Pedal

The brake pedal is located in the left foot area. To stop the machine, firmly depress the brake pedal.

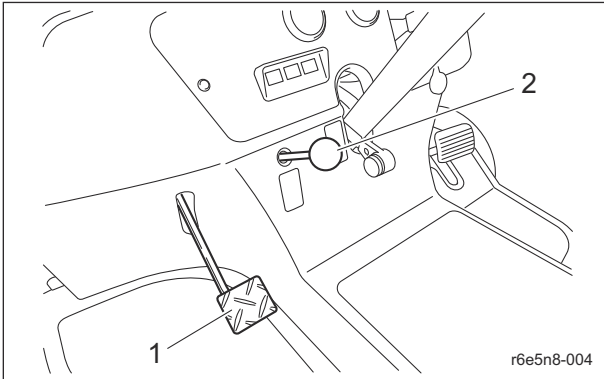

Brake Pedal\_001

1	Brake pedal
2	Parking brake lever

## Parking Brake Lever

**Caution**  
Never park the machine on a slope.

**Important**  
Be sure to release the parking brake before driving. Otherwise, the brakes or hydraulic system will malfunction.

The parking brake lever is located under the left side of the meter panel. To park the machine, depress the brake pedal and pull the parking brake lever completely. To release the parking brake, depress the brake pedal again.

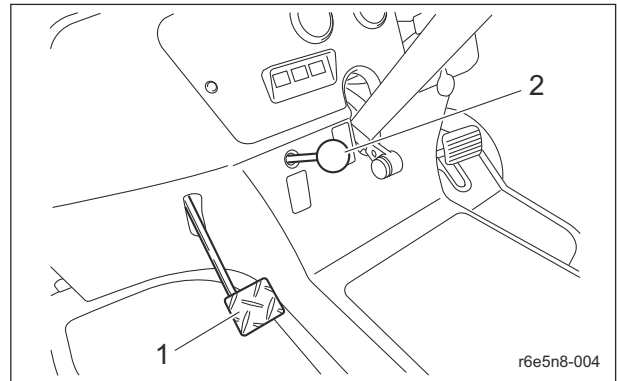

Parking Brake Lever\_001

1	Brake pedal
2	Parking brake lever

## Battery Cutoff Switch

**Important**  
After disconnecting, switch the ignition key to the "ON" position and check that the charge lamp and oil pressure lamp do not turn on.

The battery cutoff switch is located on top of the battery (behind the driver's seat, on the left). This switch connects and disconnects the negative battery cable.

When the knob is tightened to set the switch to the "ON" position, the negative battery cable is connected. When knob is loosened to set the switch to the "OFF" position, the negative battery cable is disconnected.

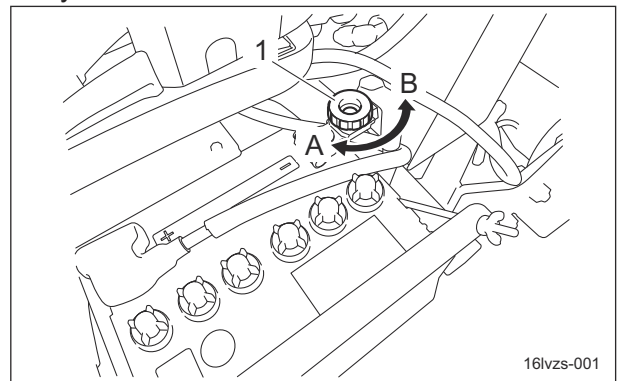

Battery Cutoff Switch\_001

1	Battery cutoff switch
A	ON (connect)
B	OFF (disconnect)

# Description of Functions

## Instruments in the Meter Panel

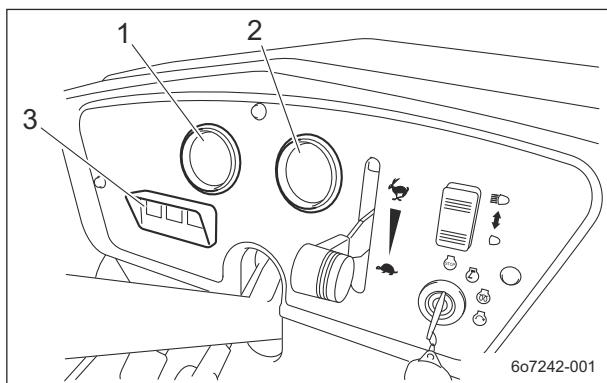

Instruments in the Meter Panel\_001

1	Water temperature gauge
2	Fuel gauge
3	Pilot lamps (charge lamp, thermo-start lamp, and oil pressure lamp)

## Fuel Gauge

The fuel gauge is located in the meter panel. This instrument indicates the quantity of fuel inside the fuel tank.

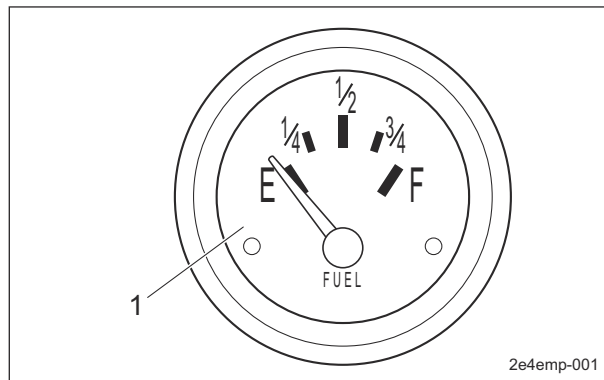

Fuel Gauge\_001

1	Fuel gauge
---	------------

## Water Temperature Gauge

The water temperature gauge is located in the meter panel.

This instrument indicates the water temperature inside the engine.

If the water temperature gauge indicates a level close to "H" during operation, the machine is overheated.

Remove the load from the engine, idle the machine for five minutes, stop the engine, and then inspect the machine and perform any necessary maintenance.

If the water temperature exceeds 105 °C (221 °F), a buzzer will sound. (intermittent tone)

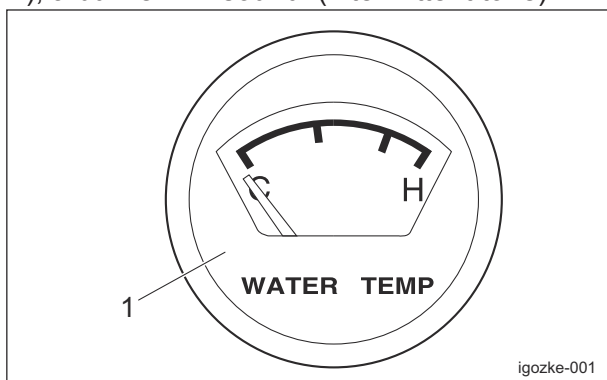

Water Temperature Gauge\_001

1	Water temperature gauge
---	-------------------------

## Pilot Lamps

### Charge Lamp

The charge lamp is the left pilot lamp, located in the meter panel.

This lamp turns on when the ignition key is set to the "ON" position before the engine starts. It turns off when the engine starts and the alternator starts operating properly.

If this lamp illuminates while you are operating the machine, stop the engine immediately, and then inspect the machine and perform any necessary maintenance.

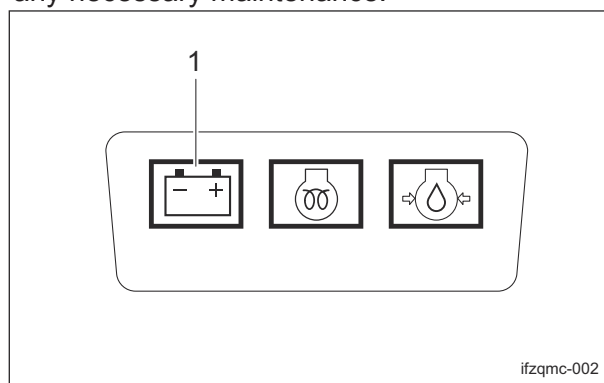

Charge Lamp\_001

1	Charge lamp
---	-------------

# Description of Functions

## Thermo-start Lamp

The thermo-start lamp is the middle pilot lamp, located in the meter panel. When the ignition key is set to the "GLOW" position, this lamp turns on while the glow plug generates heat.

Illumination of the thermo-start lamp is controlled by the glow lamp timer, and the lamp is turned off after a specified amount of time passes.

The duration of illumination indicates an approximate period of time required for warm-up, and has been fixed at five seconds.

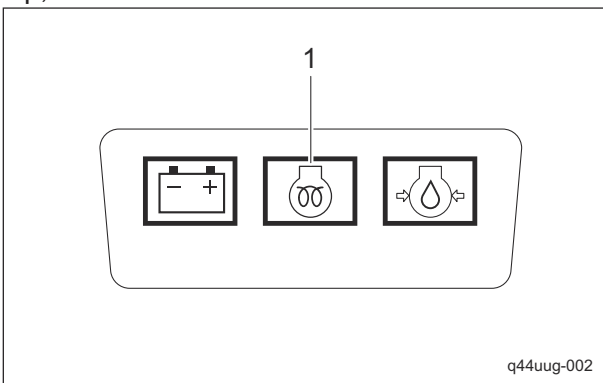

Thermo-start Lamp\_001

1	Thermo-start lamp
---	-------------------

## Oil Pressure Lamp

The oil pressure lamp is the right pilot lamp, located in the meter panel.

This lamp turns on when the ignition key is set to the "ON" position before the engine starts. It turns off when the engine starts and engine oil pressure is generated properly.

If this lamp illuminates while you are operating the machine, stop the engine immediately, and then inspect the machine and perform any necessary maintenance.

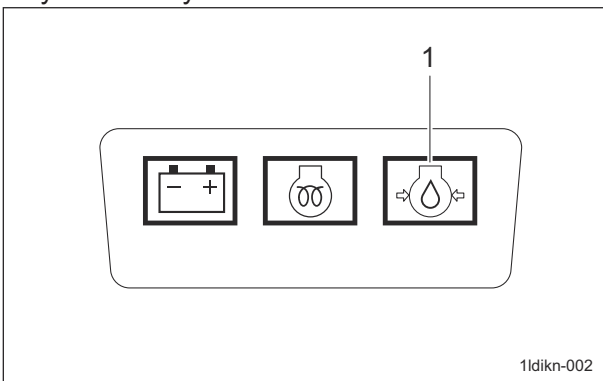

Oil Pressure Lamp\_001

1	Oil pressure lamp
---	-------------------

## Hour Meter

The hour meter indicates the accumulated operation time of the engine.

The number in red figures on a white background is incremented every thirty-six seconds.

The number in white figures on a black background is incremented every hour.

1/100 wheel ... red figures on a white background

Hour wheel ... white figures on a black background

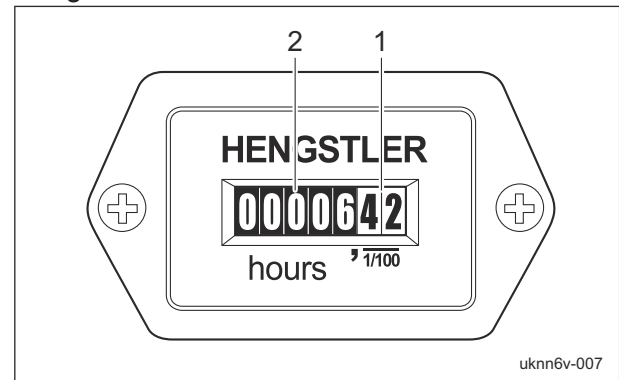

Hour Meter\_001

1	1/100 wheel
2	Hour wheel

## Safety Device

### Interlock System

This machine features an interlock system for starting and stopping the engine.

- As for starting the engine, the safety device prevents the engine from starting unless it meets each of the following four conditions.
  - An operator is sitting on the seat.
  - The parking brake is applied.
  - The reel rotation switch is set to the "OFF" position.
  - The traveling pedal is set to the neutral position.
- In the event the operator leaves the seat with the parking brake not applied and the engine running, the safety device will be activated and will stop the engine.

3. In the event the operator leaves the seat with the parking brake applied and the engine running, the safety device will be activated and will stop the engine under any of the following conditions:

- The traveling pedal is not set to the neutral position. (The operator has depressed the traveling pedal.)
- The reel rotation switch is set to the "Rotate" position.

However, when the reel forward/reverse switch is set to the "ON" position (reverse rotation), the engine does not stop.

## Warning Mechanisms

### Warning Buzzer

#### 1. Overheat Warning Buzzer

##### Important

When the buzzer (intermittent tone) sounds, be sure to stop operation since the engine is overheated.

Do not stop the engine without idling. Allow the engine to cool down, first.

Keep the engine idling for about 5 minutes before stopping.

Remove dust that is jamming in the radiator, air cleaner, and etc.

If water temperature inside the engine exceeds 105 °C (221 °F), a buzzer will sound. (intermittent tone)

Remove the load from the engine, idle the machine for five minutes, stop the engine, and then inspect the machine and perform any necessary maintenance.

# Description of Functions

---

## **Operations before Service ..... Page 5-2**

Procedure to Open/Close Hood ..... Page 5-2

Procedure to Remove/Install Rear  
Cover ..... Page 5-3

Procedure to Remove/Install Center  
Cover ..... Page 5-4

## **Inspection before Use ..... Page 5-4**

Engine .....Page 5-4

Main Vehicle ..... Page 5-7

## **Adjustment before Work ..... Page 5-11**

Adjustment of Seat Position ..... Page 5-11

Adjustment of Steering Wheel  
Position ..... Page 5-11

## **Mounting and Dismounting ..... Page 5-11**

Procedure to Mount/Dismount ..... Page 5-11

## **Start/Stop of Engine ..... Page 5-12**

Procedure to Start Engine ..... Page 5-12

Procedure to Stop Engine ..... Page 5-13

## **Parking and Stopping .....Page 5-13**

Procedure to Leave The Machine ..... Page 5-13

## **Move .....Page 5-14**

Traveling Procedure ..... Page 5-14

## **Cutting Work ..... Page 5-14**

Cutting Procedure .....Page 5-14

Procedure to Remove/Install Grass  
Catcher ..... Page 5-15

## **Transporting ..... Page 5-15**

Transporting Procedure ..... Page 5-15

## **Cleaning after Use ..... Page 5-15**

Engine .....Page 5-15

Main Vehicle ..... Page 5-17

## **Storage ..... Page 5-17**

Short-Term Storage ..... Page 5-17

# Handling Instructions

## Operations before Service

The following sections describe the preparatory works required before performing the services including inspection, adjustment, cleaning, maintenance and repair.

### Procedure to Open/Close Hood

**Caution**

Do not open the hood in strong winds.

**Caution**

Be careful not to pinch your fingers when you open or close the hood.

**Important**

Before opening the hood, be sure to lower the mower units. In addition, do not raise the mower units while the hood is open. Otherwise, the hood will be damaged.

#### 1. Procedure to open the hood

[1] Loosen the lock bolt for the hood.

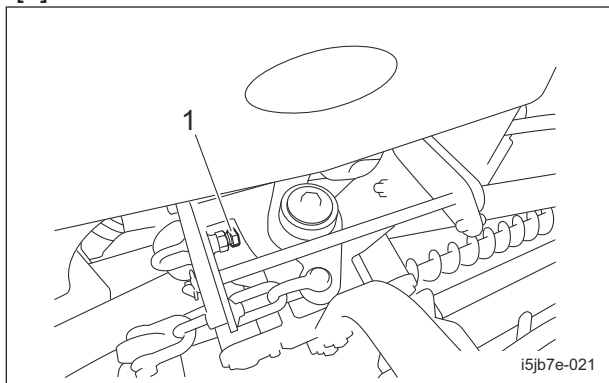

Procedure to Open/Close Hood\_001

1	Lock bolt
---	-----------

[2] Release the rubber catches on the left and right sides.

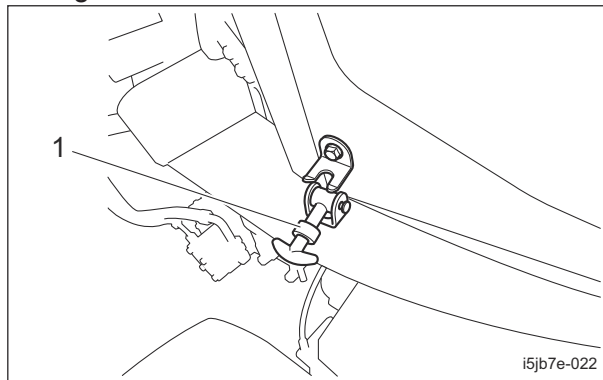

Procedure to Open/Close Hood\_002

1	Rubber catch
---	--------------

[3] Lift up the hood.

[4] Make sure that the hood will not close, and then release it.

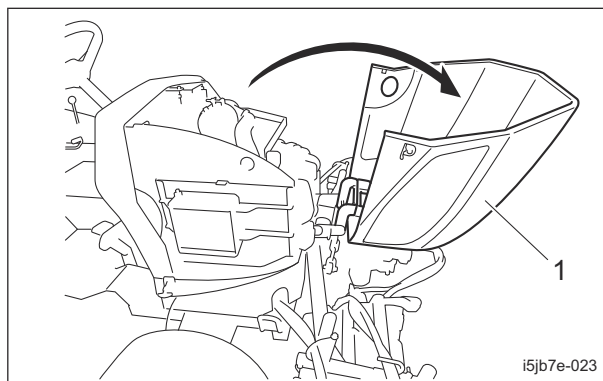

Procedure to Open/Close Hood\_003

1	Hood
---	------

#### 2. Procedure to close the hood

[1] Close the hood slowly.

[2] Securely fasten the rubber catches.

[3] Tighten the lock bolt for the hood.

# Handling Instructions

## Procedure to Remove/Install Rear Cover

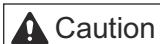

**Caution**

Do not remove the rear cover in strong winds.

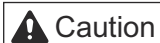

**Caution**

Be careful not to pinch your fingers when removing or installing the rear cover.

### 1. Procedure to remove the rear cover

#### [1] Remove the bolts on the rear cover.

- Left and right mounting bolts (one each)

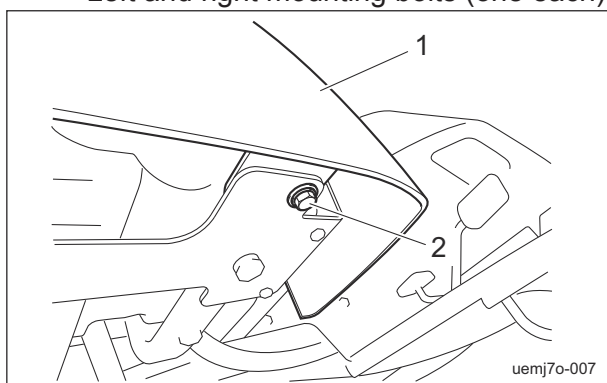

Procedure to Remove/Install Rear Cover\_001

1	Rear cover
2	Bolt

- Rear mounting bolts (two)

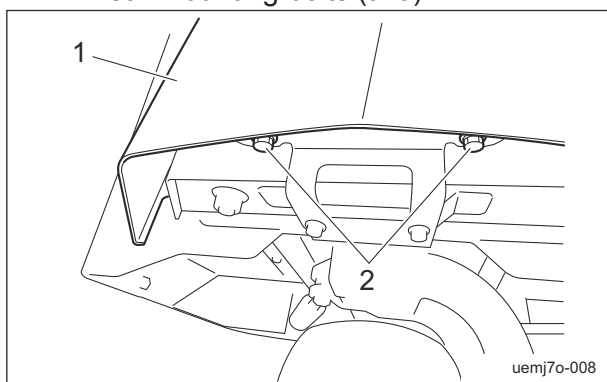

Procedure to Remove/Install Rear Cover\_002

1	Rear cover
2	Bolt

#### [2] Bring the seat to the very front position.

#### [3] If the ROPS or the ball proof net is installed, follow the steps below to fold back the ROPS.

- Remove the clip pins on the left and right sides of the ROPS, and then remove the lock pins.

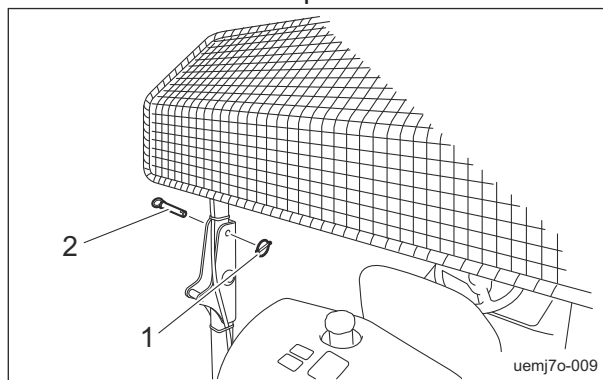

Procedure to Remove/Install Rear Cover\_003

1	Clip pin
2	Lock pin

- Fold back the ROPS.

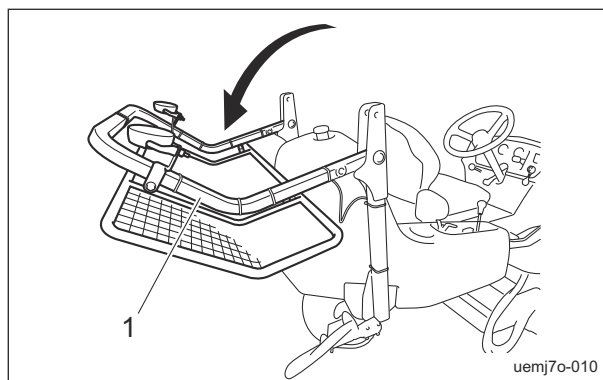

Procedure to Remove/Install Rear Cover\_004

1	ROPS
---	------

#### [4] Pull up the rear cover to remove it.

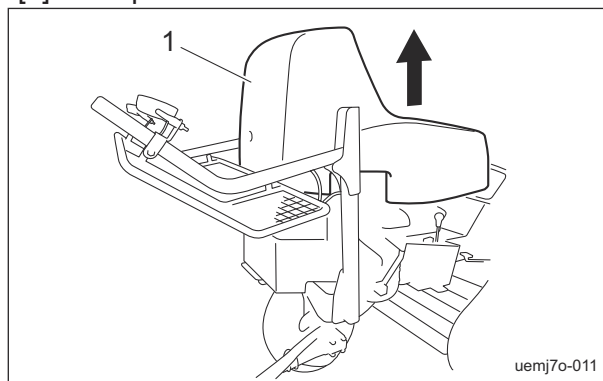

Procedure to Remove/Install Rear Cover\_005

1	Rear cover
---	------------

### 2. Procedure to install the rear cover

#### [1] Bring the seat to the very front position.

# Handling Instructions

- [2] If the ROPS or the ball proof net is installed, follow the steps below to fold back the ROPS.
- Remove the clip pins on the left and right sides of the ROPS, and then remove the lock pins.
  - Fold back the ROPS.

[3] Install the rear cover with bolts.

## Procedure to Remove/Install Center Cover

- Procedure to remove the center cover
  - Bring the seat to the backmost position.
  - Completely raise the steering wheel.
  - Remove the bolt on each side of the center cover.
  - Remove the center cover.

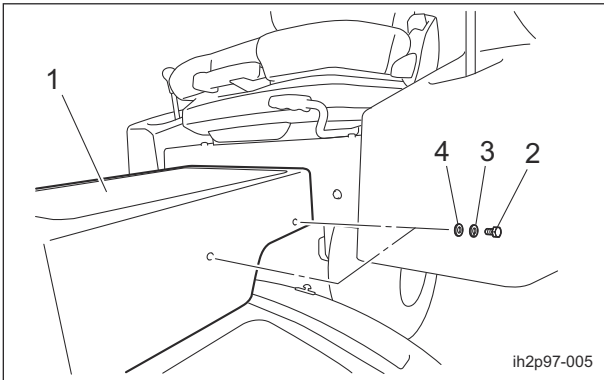

Procedure to Remove/Install Center Cover\_001

1	Center cover
2	Bolt
3	Spring washer
4	Washer

- Procedure to install the center cover
  - Bring the seat to the backmost position.
  - Completely raise the steering wheel.
  - Install the center cover with the bolts.

## Inspection before Use

The purpose of the machine inspection is to:

- Prevent accidents
- Prevent damage to the machine
- Maintain machine performance

Detecting machine malfunctions early helps prevent unexpected problems from occurring. If you detect any abnormalities with the machine, immediately perform maintenance or repairs.

## Engine

### Inspection of Engine Oil

**Important**

Securely insert the oil level gauge.

Check the contamination of oil and engine oil level to inspect the engine oil. Inspect the oil level 10 to 20 minutes after stopping the engine.

- Place the machine to set the engine on the level.
- Stop the engine.
- Open the hood.
- Pull out the oil level gauge.

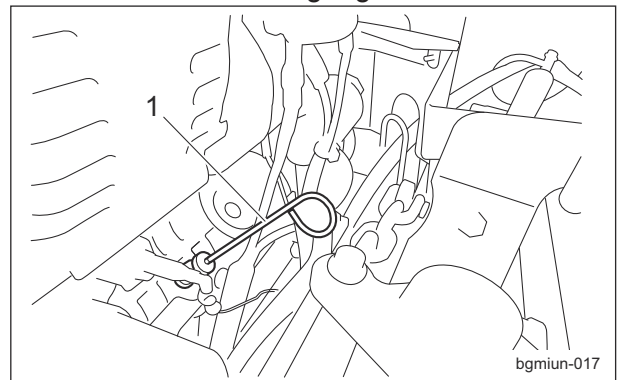

Inspection of Engine Oil\_001

1	Oil level gauge
---	-----------------

- Wipe the oil off the oil level gauge cleanly with papers or cloths.
- After wiping the oil off the oil level gauge, check the remains of contamination.
- Return the oil level gauge to its original position, insert tightly, and pull out again.
- Check the engine oil level.  
The appropriate oil level should be between the upper and lower limit lines on the gauge.

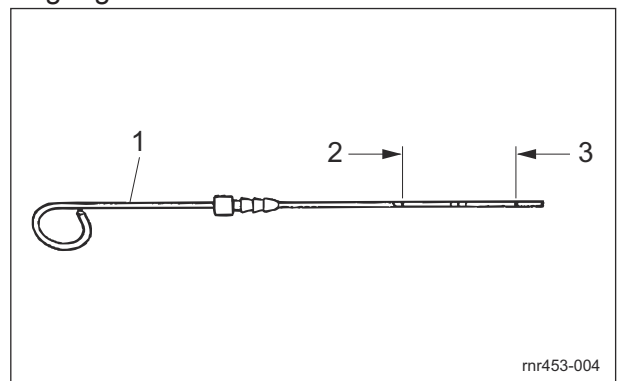

Inspection of Engine Oil\_002

# Handling Instructions

1	Oil level gauge
2	Upper limit
3	Lower limit

9. Return the oil level gauge to its original position, and insert it tightly.

10. Close the hood.

## Inspection of Fuel Quantity

With the machine on a level surface, observe the fuel gauge in the meter panel to check the fuel level.

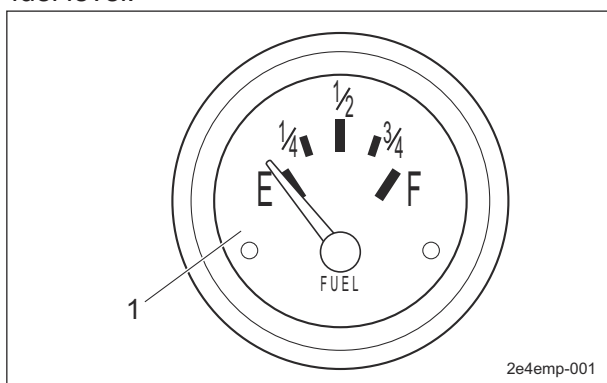

Inspection of Fuel Quantity\_001

1	Fuel gauge
---	------------

## Supply of Fuel

### Warning

Do not supply fuel above F (FULL) level of the fuel gauge.

If you supply too much fuel, it might overflow from the cap when you travel or work on a slope.

### Warning

Keep away from fire while refueling.  
Do not smoke while refueling.

If the fuel gauge in the meter panel indicates a level close to E (EMPTY), supply fuel (diesel) at your earliest convenience. The fuel tank capacity is approximately 25.0 dm<sup>3</sup> (25.0 L).

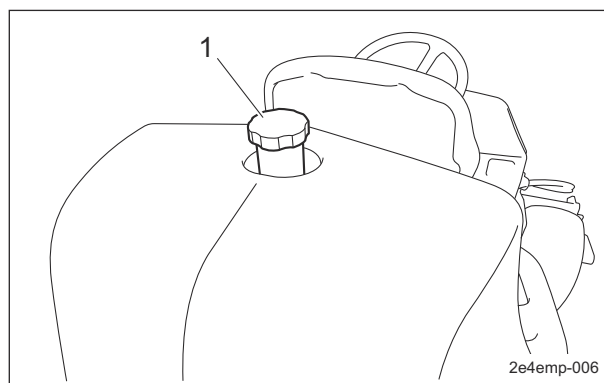

Supply of Fuel\_001

1	Tank cap
---	----------

## Inspection of Fuel Filter

1. Make sure that there is no fuel leakage.
2. Make sure that the filter is not damaged.
3. Make sure that the filter is not contaminated.

## Air Bleeding of Fuel System

### Important

Be sure to tighten the air-bleeding plug except when air bleeding. Otherwise, it may cause the engine stop.

This machine has a function of automatic air bleeding.

However, depending on the mechanical structure, it may not bleed air completely.

If the automatic air bleeding does not work well, follow the steps below to perform manual air bleeding.

1. Fill up the fuel tank with fuel and open the fuel cock.
2. Loosen the air-bleeding plug of the fuel filter 2 to 3 turns.
3. If air bubble of the fuel from the plug has gone, tighten the plug.

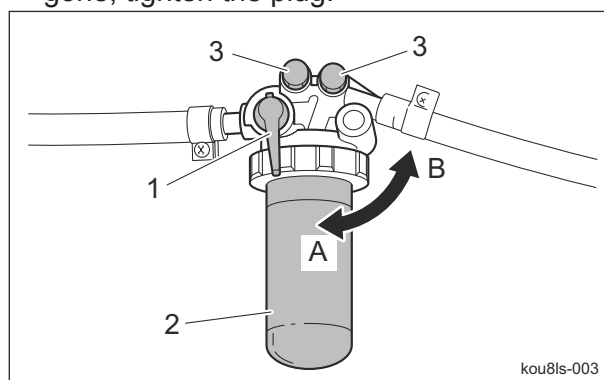

Air Bleeding of Fuel System\_001

# Handling Instructions

1	Fuel cock
2	Fuel filter
3	Air-bleeding plug
A	ON (Open)
B	OFF (Close)

4. Loosen the air-bleeding plug of the injection pump.

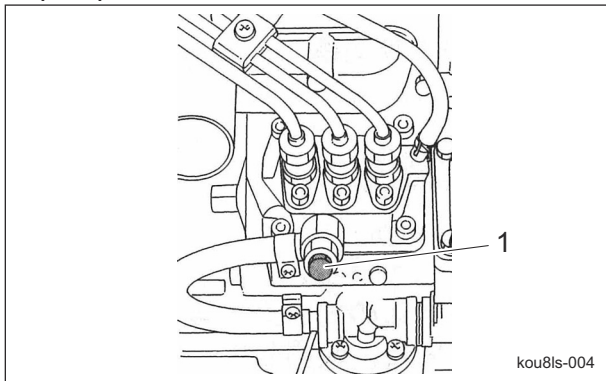

Air Bleeding of Fuel System\_002

1	Air-bleeding plug
---	-------------------

5. Sit on the operator's seat.
6. Make sure that the parking brake is applied.
7. Set the reel rotation switch to the "STOP" position.
8. Make sure that the traveling pedal is in the neutral position.
9. Set the ignition key to the "START" position.

**Important**

In the case that there are still air bubbles in the fuel from air-bleeding plug even after 15 seconds or more passed after setting the ignition key to "START", pause for 30 seconds or more and then repeat the same procedure.

10. If the starter rotates and air bubble of the fuel from the air-bleeding plug has gone, return the ignition key slowly to "OFF" position and tighten the plug.

### Inspection of Coolant

**Caution**

Do not touch the radiator or coolant during engine operation or immediately after the engine has been turned off. Otherwise, you may get burned.

**Caution**

Inspection should take place after the engine has well cooled down.

1. Make sure that the coolant level in the reserve tank is between "FULL" and "LOW."

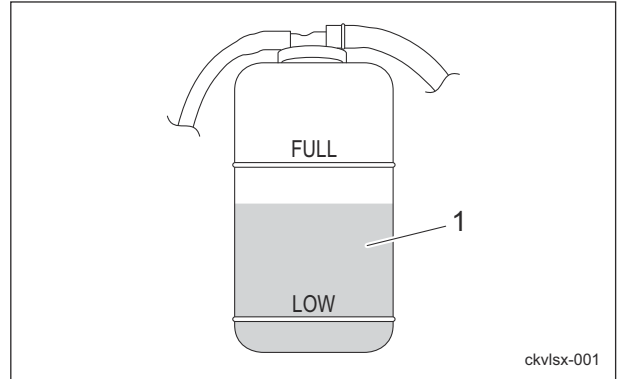

Inspection of Coolant\_001

1	Reserve tank
---	--------------

### Inspection of Air Cleaner

The air cleaner is a component that removes dirt from the intake air to prevent wear of the cylinder liners and piston rings so that the engine will always operate smoothly. A contaminated air cleaner element may cause malfunction of the engine.

1. Make sure that there is no damage to the air cleaner.
2. Make sure that the air cleaner filter is not contaminated.

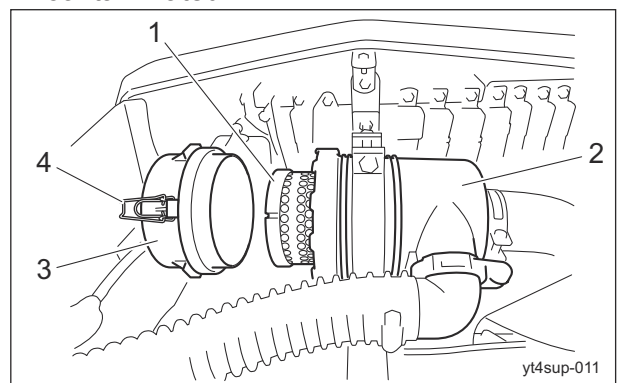

Inspection of Air Cleaner\_001

1	Air cleaner filter
2	Air cleaner body
3	Air cleaner cap
4	Clip

# Handling Instructions

## Inspection of Dust-proof Mesh

1. Make sure that there is no damage to the dust-proof mesh.
2. Make sure that the dust-proof mesh is not contaminated.

## Inspection of Radiator

1. Make sure that there is no damage to the radiator.
2. Make sure that the radiator is not contaminated.

## Inspection of Engine-Associated Parts

### Caution

Perform operations after the muffler, engine and other parts have sufficiently cooled. Otherwise, you may get burned.

1. Check for damages and dirt.
2. Check the mount for looseness and cracks.
3. Check for liquid leakage.
4. Check on and around the muffler for grass clippings and flammable materials.

## Main Vehicle

### Inspection of Hydraulic Oil

The oil gauge is on the side of the hydraulic tank.

1. Lower the mower units and maintain that position on a level surface.
2. Make sure that the oil level is at the middle of the oil gauge.

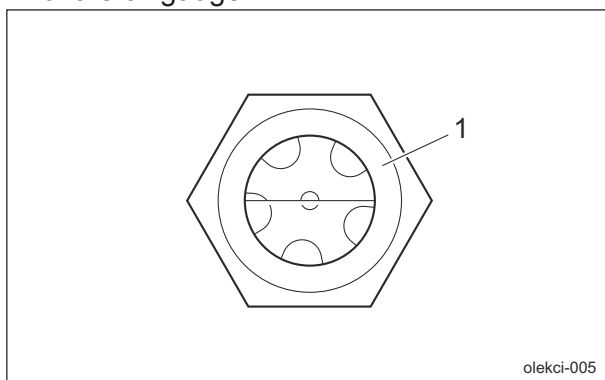

Inspection of Hydraulic Oil\_001

1	Oil gauge
---	-----------

3. Check underneath the machine for oil leakage.

## Inspection of Tires

1. Check the pneumatic pressure of the tires.
2. Make sure that there are no cracks, damage or abnormal wear.

	Tire size	Pneumatic pressure	
Front wheel	20 x 12.00-10	140 kPa (1.4 kgf/cm <sup>2</sup> )	20 psi
Rear wheel	20 x 8.00-10	140 kPa (1.4 kgf/cm <sup>2</sup> )	20 psi

## Inspection of Battery

### Danger

Keep away from fire while inspecting or charging the battery. The battery may explode.

### Caution

Implement after the engine and muffler etc. have well cooled down. Otherwise, you may get burned.

### Important

Be sure to stop the engine before inspecting or charging the battery.

Battery inspection items are described below.

1. Inspecting the exterior  
Visually inspect the exterior of the battery, and check that there are no cracks, splits, missing sections, or abnormal deformation in the battery case, and that there is no electrolyte leaking. If abnormalities are found, immediately replace the battery.

# Handling Instructions

## 2. Cleaning the exterior

### Warning

Do not clean the battery with a dry cloth. Cleaning the battery with a dry cloth may cause it to catch fire or explode due to static electricity.

Use a wet cloth for cleaning.

Inspect the vent plugs or vent holes on the side of the battery, and if they are blocked by dirt wash them with water to remove the blockage.

Continuing to use the battery with the vent holes blocked may cause the battery to rupture from increased internal pressure due to gases generated inside the battery.

## 3. Inspecting the mounting bracket

Inspect whether the battery is secured firmly with the mounting bracket.

If the bracket is loose, tighten the mounting bracket nuts until the battery is secured firmly.

An improperly mounted battery may cause damage to the battery case or electrolyte leaks due to the battery moving with vibrations while traveling.

## 4. Inspecting the cable terminals

If the connection between the battery terminals and vehicle's cable terminals are loose, tighten the nuts until the cable terminals are secured firmly.

Insufficiently tightened terminals may result in poor battery charging, damage to the terminals due to poor contacts, or an explosion.

If the terminals are corroded, rub them clean with a wire brush or fine grit sandpaper, and lightly apply anti-rust grease.

## 5. Inspecting the electrolyte level and refilling

### Warning

Do not allow the battery fluid level to become lower than the LOWER LEVEL (minimum fluid level line).

The battery may explode if it is used or charged while the battery fluid level is at the LOWER LEVEL (minimum fluid level line).

### Warning

When refilling, do not fill purified water above the UPPER LEVEL line.

Doing so may result in electrolyte leaks.

Clean the areas around the battery fluid level lines using a cloth dampened with water to check the electrolyte level from the side of the battery.

Make sure that the battery fluid level is between the UPPER LEVEL (maximum fluid level line) and the LOWER LEVEL (minimum fluid level line).

Refill with purified water up to the UPPER LEVEL line if the level is lower than halfway between the UPPER LEVEL and LOWER LEVEL lines.

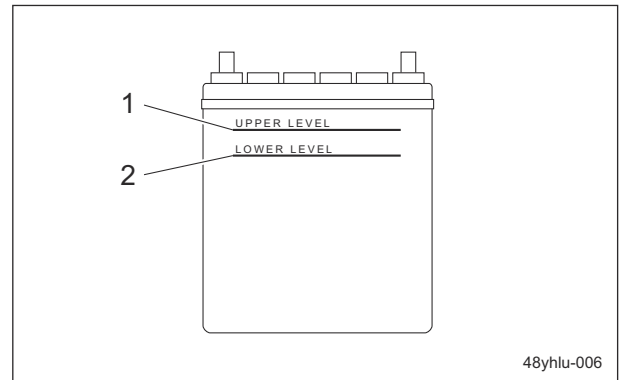

Inspection of Battery\_001

1	UPPER LEVEL line
2	LOWER LEVEL line

## Inspection of Oil Cooler

1. Make sure that there is no damage to the oil cooler.
2. Make sure that the oil cooler is not contaminated.

# Handling Instructions

## Inspection of Covers

### Warning

If you have removed the cover during inspection, make sure that you replace it in the original position securely. If the cover remains removed, the operator or the mechanic may come in contact with the rotating objects or belt, or foreign objects may fly off, possibly resulting in injuries.

1. Make sure that there is no wear or deterioration of covers.
2. Make sure that there is no damage to covers.
3. Make sure that there is no interference with moving parts due to deformation of covers.
4. Make sure that covers are installed in their appropriate positions.

## Inspection of Wire

1. Make sure that the wire is not cracked or damaged.
2. Make sure that the wire is not worn.
3. Make sure that the wire is not crushed.
4. Make sure that the wire is not bent.
5. Make sure that the wire is not corroded or rusted.

## Inspection of Brake Pedal

1. Make sure that there is no play in the pedal.
2. Make sure that the pedal moves smoothly.
3. Make sure that there is no abnormal sound when the pedal is depressed.
4. Make sure that the pedal does not touch the floorboard when the pedal is depressed.

## Inspection of Parking Brake Lever

1. Make sure that the brake pedal is locked after depressing the brake pedal completely and pulling the parking brake lever completely.
2. Make sure that the brake pedal is released after depressing the brake pedal again.

## Inspection of Traveling Pedal

1. Make sure that there is no play in the pedal.
2. Make sure that the pedal moves smoothly.

3. Make sure that there is no abnormal sound when the pedal is depressed.

## Inspection of Liquid Leakage

### Important

After approximately 50 hours of operation, some tightened portions may be loosened and liquid such as oil may leak. Be sure to retighten the parts.

### Important

Repair the machine before operation if liquid leakage found. Ignoring leakage will cause further trouble.

1. Check the bottom of the machine for leakage of liquid such as oil, water, fuel, etc.
2. Locate the leakage and identify the type of liquid.

## Inspection of Ball Proof Net

1. Check the ball proof net is not deteriorated.
2. Check there is no damage nor deformation of the ball proof net.

## Inspection of Bolts and Nuts

### Important

The bolts and nuts may be loosened at the earlier stage of the use. Be sure to retighten or replace before operating the machine whenever there is any abnormality.

1. Check the bolts and nuts for looseness and coming off.
2. Check the bolts and nuts for cracks and damages.
3. Check the bolts and nuts for rust.
4. Check around the bolts and nuts for traces of rust fluid.
5. Check for unequal bolt length.
6. Check the bolts and nuts for stripped threads and abrasion.

# Handling Instructions

---

## Inspection of Hour Meter

1. Check the hour meter is not damaged.
2. Check the hour meter operates correctly.
  - [1] Switch the ignition key to the "ON" position.
  - [2] Check the displayed number increases correctly.
  - [3] Switch the ignition key to the "OFF" position.

## Inspection of Water Temperature Gauge

1. Check the water temperature is not damaged.
2. Check the water temperature operates correctly.
  - [1] Switch the ignition key to the "ON" position.
  - [2] Check the water temperature needle swings.
  - [3] Switch the ignition key to the "OFF" position.

## Inspection of Fuel Gauge

1. Check the fuel gauge is not damaged.
2. Check the fuel gauge operates correctly.
  - [1] Switch the ignition key to the "ON" position.
  - [2] Check the fuel gauge needle swings.
  - [3] Switch the ignition key to the "OFF" position.

## Inspection of Pilot Lamps

1. Check the pilot lamps are clean.
2. Check the pilot lamps are not damaged.

## Inspection of Safety Device

Repair the machine before operation whenever there is any abnormality.

1. Interlock system
 

Make sure that the interlock system operates correctly.  
"Interlock System" (Page 4-8)
2. ROPS
 

(If the machine is equipped with ROPS and a seat belt)  
Make sure that the ROPS is not damaged or broken.

## 3. Seat belt

(If the machine is equipped with ROPS and a seat belt)  
Make sure that the seat belt is not damaged or broken.

## Inspection of Steering Wheel

1. Make sure that there is no play in the steering wheel.
2. Make sure that the steering wheel turns smoothly when it is turned.
3. Make sure that there is no abnormal sound when the steering wheel is turned.
4. Check the direction of tires when the steering wheel is turned.
  - [1] Start the engine.
  - [2] Make sure that the rear tire turns left when the steering wheel is turned right.
  - [3] Make sure that the rear tire turns right when the steering wheel is turned left.
  - [4] Stop the engine.

## Inspection of Light

### Note:

Depending on the specifications, this function may not be available.

1. Check the lights are not damaged.
2. Check the lights turn on/off.
  - [1] Switch the ignition key to the "ON" position.
  - [2] Set the light switch to the "ON" position.
  - [3] Check the lights have turned on.
  - [4] Set the light switch to the "OFF" position.
  - [5] Check the lights have turned off.
  - [6] Switch the ignition key to the "OFF" position.

## Inspection of Grass Catcher

1. Make sure that there is no wear or deterioration of the grass catcher.
2. Make sure that there is no damage to the grass catcher.
3. Make sure that there is no interference to moving parts due to deformation of the grass catcher.

# Handling Instructions

## Adjustment before Work

### Adjustment of Seat Position

#### ⚠ Warning

Do not adjust while traveling since it is dangerous.

Adjust the position to fit the operator.

1. Use the forward/backward adjustment lever to adjust the seat back and forth.
2. Use the backrest tilt adjustment lever to adjust the angle of the backrest.
3. Pull out the suspension adjustment handle and move it up or down to adjust the firmness of the seat suspension. Observe the suspension adjustment scale while making adjustments. [50 - 160 kg (110.2 - 352.7 lb)]

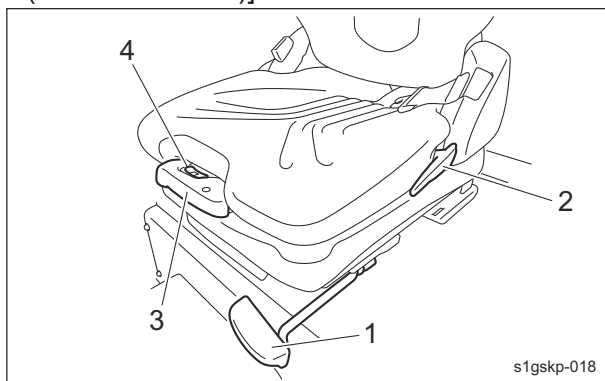

Adjustment of Seat Position\_001

1	Forward/backward adjustment lever
2	Angle adjustment lever
3	Suspension adjustment handle
4	Suspension adjustment scale

### Adjustment of Steering Wheel Position

#### ⚠ Warning

Do not make adjustments while traveling since doing so is dangerous.

#### ⚠ Caution

Be sure the steering wheel position is securely locked. It may result in an unexpected accident if it becomes loose while traveling.

The steering wheel position can be adjusted up or down.

Adjust the position to fit the operator.

Shift the tilt lever to the "FREE" position, move the steering wheel to the position that suits the work requirements, and then shift the tilt lever to the "LOCK" position to secure the steering wheel in place.

The tilt lever is located at the left in front of the driver's seat.

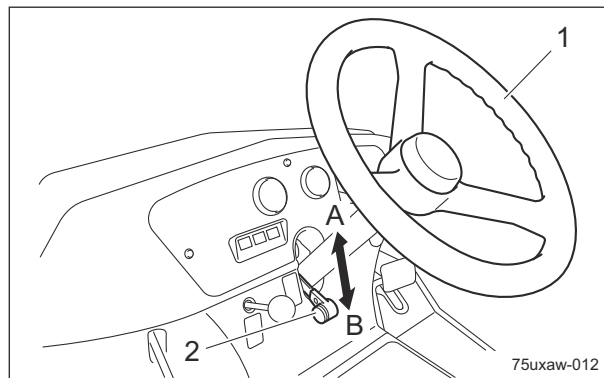

Adjustment of Steering Wheel Position\_001

1	Steering wheel
2	Tilt lever
A	FREE (released)
B	LOCK (locked)

## Mounting and Dismounting

### Procedure to Mount/Dismount

This machine is equipped with a step for mounting/dismounting.

Place your foot on the step when mounting and dismounting the machine.

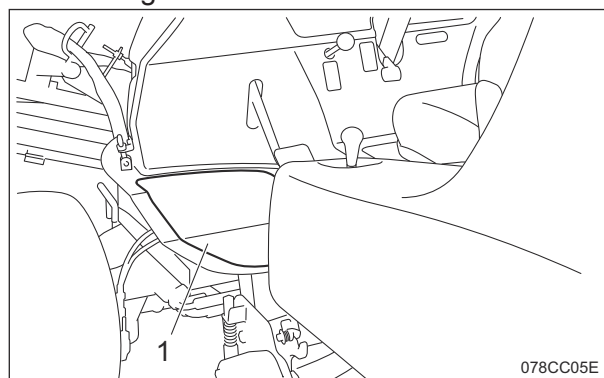

Procedure to Mount/Dismount\_001

1	Step
---	------

# Handling Instructions

## Start/Stop of Engine

### Procedure to Start Engine

**Caution**

Before starting the engine, make sure that there are no other people or obstacles around the machine.

**Caution**

Starter operation must take 15 seconds or less. If the engine still does not start, stop using the battery for 30 to 60 seconds to avoid exhausting the battery.

1. Make sure that the fuel cock of the water separator is open.
2. Make sure that the fuel filter cock is open.

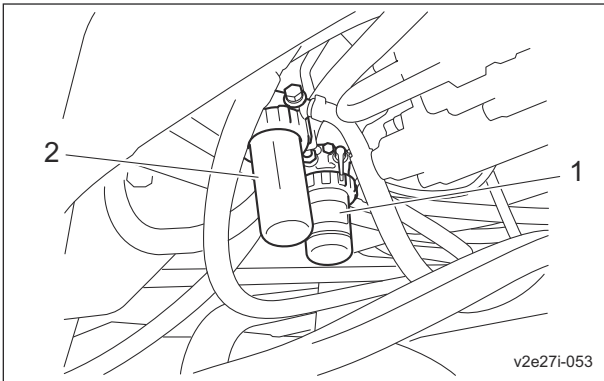

Procedure to Start Engine\_001

1	Water Separator
2	Fuel filter

3. Sit on the seat.
4. Make sure that you have depressed the brake pedal and applied the parking brake.
5. Set the reel rotation switch to the "Stop" position.
6. Move the mower unit up/down lever to the neutral position.
7. Make sure that the traveling pedal is in the neutral position.

8. Shift the throttle lever from the "Low speed" position halfway to the "High speed" position.

**Important**

The thermo-start lamp turns off at the specified time. However, the lamp turning off is not related to the glow plug generating heat. If the ignition key is left in the "GLOW" position after the lamp is turned off, the plug will still generate heat. The thermo-start lamp will stay illuminated for five seconds.

9. Switch the ignition key to the "GLOW" position.

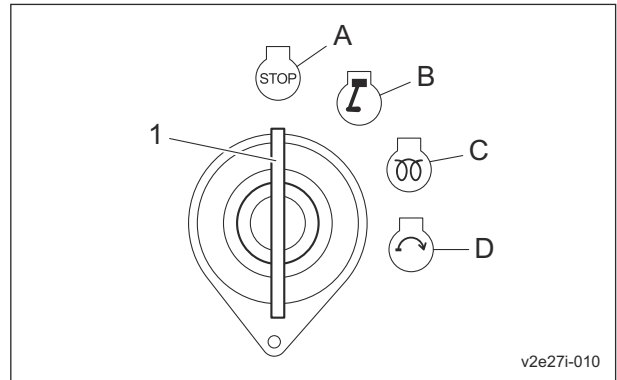

Procedure to Start Engine\_002

1	Ignition key
A	OFF
B	ON
C	GLOW
D	START

10. Make sure that the thermo-start lamp is turned on.

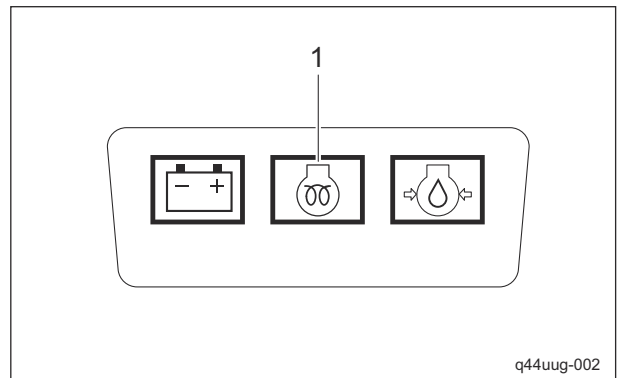

Procedure to Start Engine\_003

1	Thermo-start lamp
---	-------------------

# Handling Instructions

11. After the thermo-start lamp turns off, immediately set the ignition key to the "START" position.

### Important

Quickly returning the ignition key from the "START" position to the "ON" position may result in damage to the device.

12. When the starter starts rotating and the engine starts, slowly return the ignition key to the "ON" position.
13. Make sure that the charge lamp and oil pressure lamp turn off. If they do not turn off, stop the engine and inspect the machine.

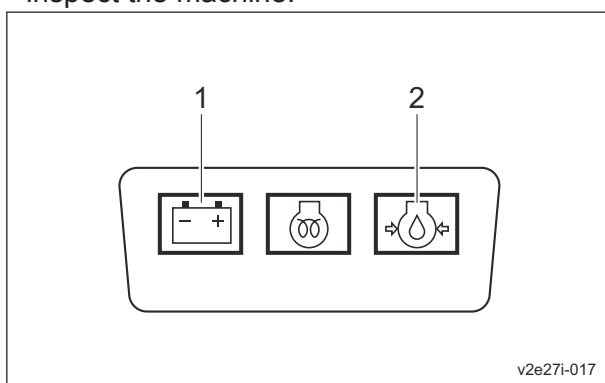

Procedure to Start Engine\_004

1	Charge lamp
2	Oil pressure lamp

14. Move the throttle lever to the "Low speed" position, and then warm up the engine so that the needle points above "C" on the water temperature gauge.

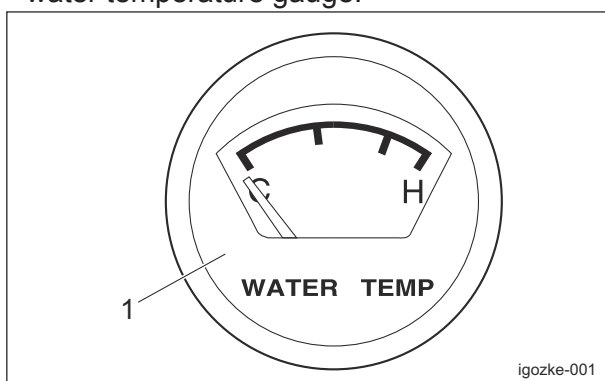

Procedure to Start Engine\_005

1	Water temperature gauge
---	-------------------------

## Procedure to Stop Engine

1. Set the traveling pedal to the neutral position.
2. Apply the parking brake.
3. Set the reel rotation switch to the "Stop" position.
4. Shift the throttle lever to the "Low speed" position, and then warm up the engine for 1-2 minutes.
5. Lower all the mower units to the ground.
6. Switch the ignition key to the "OFF" position.
7. Make sure that the engine has stopped.

## Parking and Stopping

### Procedure to Leave The Machine

#### ⚠ Caution

If the brakes are not sufficiently effective, use the wheel stoppers to secure the machine.

#### ⚠ Caution

Never park the machine on a slope.

1. Park the machine on level ground.
2. Apply the parking brake.
3. Stop the engine.
4. Remove the ignition key.
5. Install the cap to the key switch.
6. Leave the driver's seat.

# Handling Instructions

## Move

### Traveling Procedure

#### ⚠ Caution

Under any circumstances drive the machine at such a speed that you can stop it immediately for emergencies.

#### ⚠ Caution

Since traveling on steep downward slopes, wet surfaces and wet grassy downward slopes in 3WD is dangerous, use 2WD. Otherwise, the rear tires may slip and travel control may be lost.

#### Important

Do NOT start to move or stop the machine abruptly. It will damage the hydraulic system or result in oil leakage.

1. Start the engine.  
"Procedure to Start Engine" (Page 5-12)
2. Raise all mower units.
3. Move the throttle lever toward "High speed" to rev up the engine to MAX.
4. Depress the brake pedal to release the parking brake.
5. Release the brake pedal.
6. Slowly depress the traveling pedal.
7. The machine starts traveling.
8. The machine stops with the traveling pedal released and the brake pedal depressed.

## Cutting Work

### Cutting Procedure

#### ⚠ Warning

Do NOT start to move or stop the machine abruptly.

#### ⚠ Caution

Cutting work must be performed at an appropriate speed for the site and location. When cutting over bumpy surfaces, keep the engine rpm steady, and slow down the cutting speed.

#### ⚠ Caution

Reel rotation will be turned on or off based on the sensor-detected position of the mower units. Please note that if you stop operating the mower unit up/down lever before the mower units are raised completely, reel rotation may not stop.

#### Important

Mow with the lever shifted to the "DOWN" position. When the lever is returned to the neutral position, the cylinders are fixed, preventing mowing on undulations.

#### Important

Do NOT start to move or stop the machine abruptly. It will damage the hydraulic system or result in oil leakage.

1. Shift the reel rotation/stop switching levers of all mower units to the "Rotation" position.
2. Start the engine.  
"Procedure to Start Engine" (Page 5-12)
3. Depress the brake pedal to release the parking brake.
4. Shift the throttle lever to the "High speed" position to run the engine at the maximum speed.
5. Shift the mower unit up/down lever to the "DOWN" position to lower the mower units.
6. Set the reel rotation switch to the "Rotation" position to rotate the reel cutters (cutting cylinders) of all mower units.
7. Depress the traveling pedal to start cutting work.

# Handling Instructions

## Procedure to Remove/Install Grass Catcher

### ⚠ Caution

Stop the engine before removing or installing the grass catcher.

1. Set the reel rotation switch to the "Stop" position.
  2. Lower the mower units.
  3. Apply the parking brake.
  4. Stop the engine.
  5. Remove or install the grass catcher.
- Removal of grass catcher:  
Lift up the grass catcher, and remove the mounting pins on the left and right of the grass catcher from the grass catcher mounting brackets.

Installation of grass catcher:

Install the mounting pins on the left and right sides of the grass catcher into the grass catcher mounting brackets.

Mower unit #1

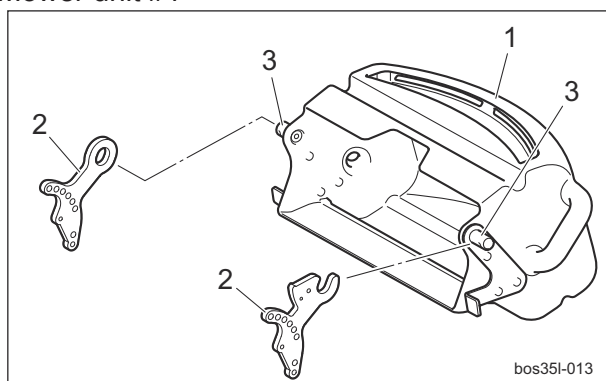

Procedure to Remove/Install Grass Catcher\_001

1	Grass catcher
2	Grass catcher mounting bracket
3	Mounting pin

Mower unit #2

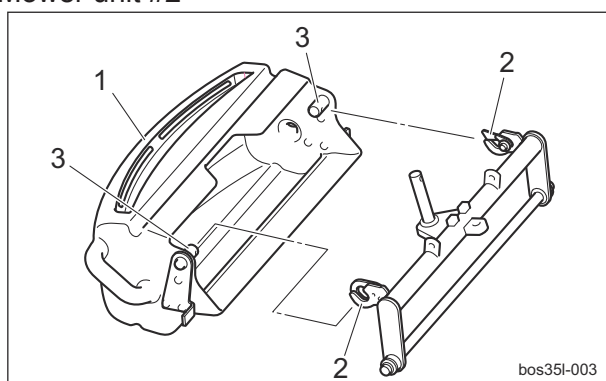

Procedure to Remove/Install Grass Catcher\_002

1	Grass catcher
2	Grass catcher mounting bracket
3	Mounting pin

Mower unit #3

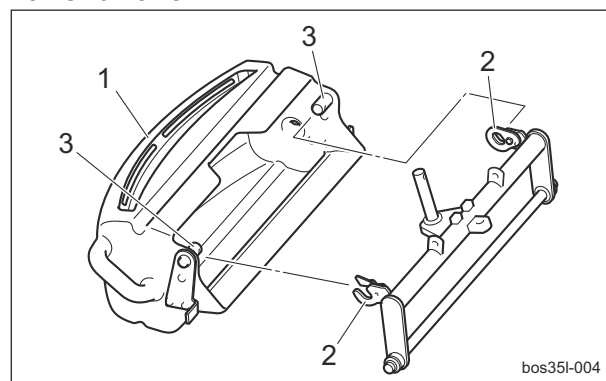

Procedure to Remove/Install Grass Catcher\_003

1	Grass catcher
2	Grass catcher mounting bracket
3	Mounting pin

## Transporting

### Transporting Procedure

When loading the machine into a trailer or a truck to transport it, drive the machine forward. When unloading, drive the machine in reverse.

## Cleaning after Use

The purpose of the machine cleaning is to:

- Prevent accidents
- Prevent damage to the machine
- Maintain machine performance

Properly clean the machine to maintain its functionality and performance.

If you detect any abnormalities with the machine, immediately perform maintenance or repairs.

## Engine

### Cleaning of Engine-Associated Parts

### ⚠ Caution

Perform operations after the muffler, engine and other parts have sufficiently cooled. Otherwise, you may get burned.

1. Clean clippings and remove dirt.
2. Blow compressed air to clean any grass or flammable materials that may be attached on or around the muffler.

# Handling Instructions

## Cleaning of Dust-Proof Mesh

**Important**

An unclean dust-proof mesh may cause the engine to overheat. It may also cause malfunction of the hydraulic system.

If the dust-proof mesh has been contaminated with dust, be sure to clean it. Especially after operating the machine in a dusty environment, it is important to remove dust as soon as possible.

1. Open the hood.
2. Pull up the dust screen to remove it.
3. Carefully clean the front and back of the dust-proof mesh with water or compressed air.
4. Install the dust-proof mesh.

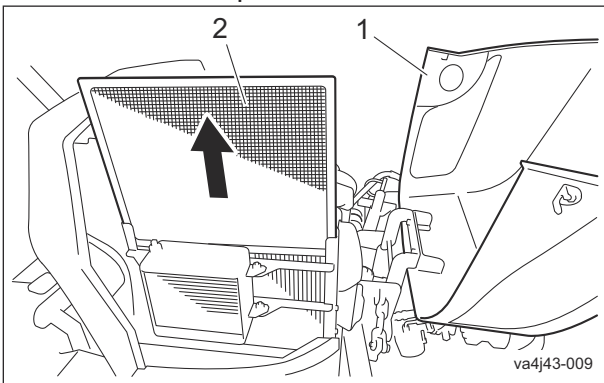

Cleaning of Dust-Proof Mesh\_001

1	Hood
2	Dust-proof mesh

## Cleaning of Radiator

**Important**

An unclean radiator may cause the engine to overheat. It may also cause malfunction of the hydraulic system.

**Important**

Do not use solid objects, such as a spatula or screwdriver, or high-pressure water to clean the radiator or oil cooler. Otherwise, special fins or tubes may be damaged, possibly resulting in reduced cooling performance or coolant leakage.

1. Open the hood.  
"Procedure to Open/Close Hood" (Page 5-2)
2. Pull up the dust screen to remove it.

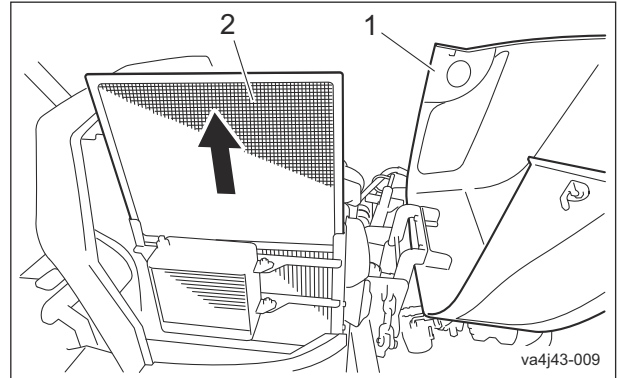

Cleaning of Radiator\_001

1	Hood
2	Dust screen

3. Carefully clean the front and back of the dust screen and radiator with water or compressed air.

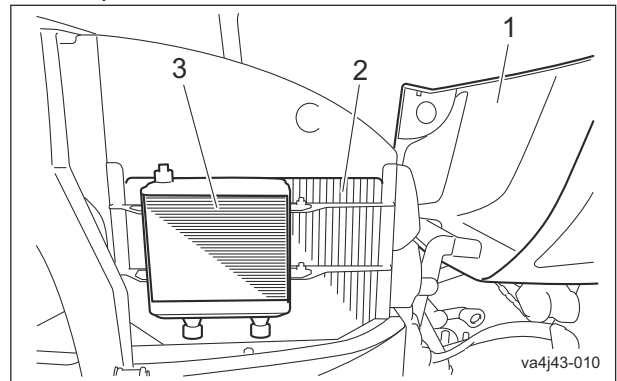

Cleaning of Radiator\_002

1	Hood
2	Radiator
3	Oil cooler

# Handling Instructions

## Main Vehicle

### Cleaning of Oil Cooler

#### Important

An unclean oil cooler may cause malfunction of the hydraulic system.

#### Important

Do not use solid objects, such as a spatula or screwdriver, or high-pressure water to clean the radiator or oil cooler.

Otherwise, special fins or tubes may be damaged, possibly resulting in reduced cooling performance or coolant leakage.

If the oil cooler has been contaminated with dust, be sure to clean it.

Especially after operating the machine in a dusty environment, it is important to remove dust as soon as possible.

#### 1. Open the hood.

"Procedure to Open/Close Hood" (Page 5-2)

#### 2. Carefully clean the front and back of the oil cooler with water or compressed air.

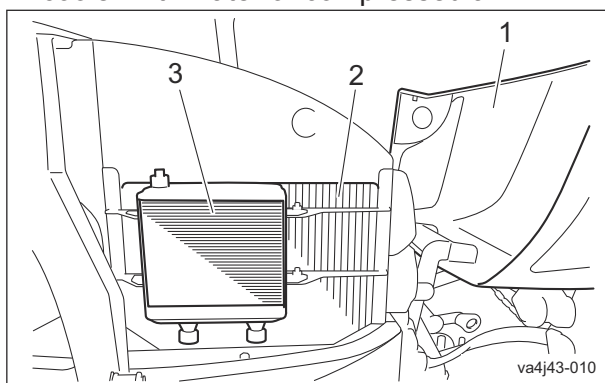

Cleaning of Oil Cooler\_001

1	Hood
2	Radiator
3	Oil cooler

## Storage

### Short-Term Storage

Short-term storage means that the machine is temporarily stored (within 1 month) without use.

Follow the instructions below for short-term storage of the machine.

#### 1. Cleaning

- Remove dirt, grass clippings, oil stains etc. completely from the main vehicle and engine.

#### 2. Mower units

- When storing this machine, lower all the mower units unless a positive mechanical lock is provided.

#### 3. Storage location

- Cover the machine and store it in a dry place where it will not be exposed to rain.

# Handling Instructions

---

<b>Precautions for Maintenance .....</b>	<b>Page 6-2</b>
<b>Jacking Up The Machine .....</b>	<b>Page 6-2</b>
About Jacking Up The Machine .....	Page 6-2
Jack-up Points .....	Page 6-2
<b>Hoisting The Machine .....</b>	<b>Page 6-3</b>
About Hoisting The Machine .....	Page 6-3
Lifting Points .....	Page 6-4
<b>Inspection and Cleaning .....</b>	<b>Page 6-4</b>
Engine .....	Page 6-4
Main Vehicle .....	Page 6-8
<b>Supplying Fluids .....</b>	<b>Page 6-9</b>
Engine .....	Page 6-9
Main Vehicle .....	Page 6-11
<b>Greasing .....</b>	<b>Page 6-13</b>
About Greasing .....	Page 6-13
Greasing Points .....	Page 6-13
<b>Lubrication .....</b>	<b>Page 6-17</b>
About Lubrication .....	Page 6-17
Lubricating Points .....	Page 6-17
<b>Adjustment .....</b>	<b>Page 6-18</b>
Engine .....	Page 6-18
Main Vehicle .....	Page 6-19
<b>Replacement .....</b>	<b>Page 6-22</b>
Engine .....	Page 6-22
Main Vehicle .....	Page 6-26
<b>Storage .....</b>	<b>Page 6-32</b>
Long-Term Storage .....	Page 6-32

# Maintenance

## Precautions for Maintenance

**Warning**

The chapter "Maintenance" in this manual describes practical measures which should be performed by a mechanic with expertise. The owner should instruct the mechanic with expertise to perform maintenance service for this machine.

**Caution**

First, learn well the operations you plan to perform.

**Important**

Use tools appropriate for each operation.

**Important**

Use Baronsess genuine parts for replacement and accessories. Our product warranty may be void if you use non-genuine parts for replacement or accessories.

## Jacking Up The Machine

### About Jacking Up The Machine

**Warning**

When replacing a tire or beginning any other maintenance or repairs, be sure to chock the wheels to prevent the machine from moving. Before jacking up the machine, park it on a hard, flat surface such as a concrete floor and remove any obstacles that could prevent you from performing the work safely. When necessary, use an appropriate chain block, hoist, or jack. Support the machine securely with jack stands or appropriate blocks. Failure to do so may cause the machine to move or fall, resulting in injury or death.

**Important**

Only place a jack under the jack-up points specified. Placing a jack at any other point will result in damage to the frame or other parts.

Use the jack-up points identified in this manual when jacking up the machine.

### Jack-up Points

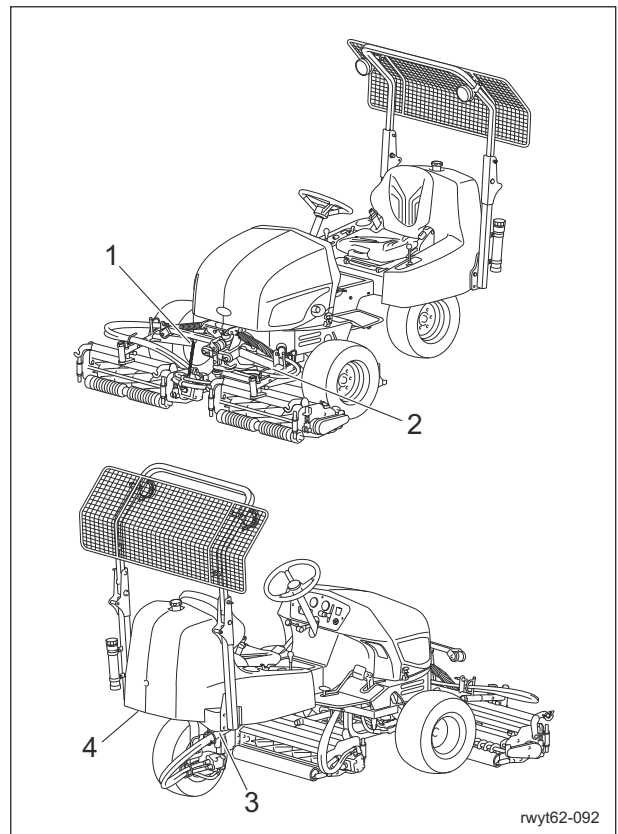

Jack-up Points\_001

	Jack-up Points
1	Front right frame
2	Front left frame
3	Rear right frame
4	Rear left frame

### 1. Front right frame

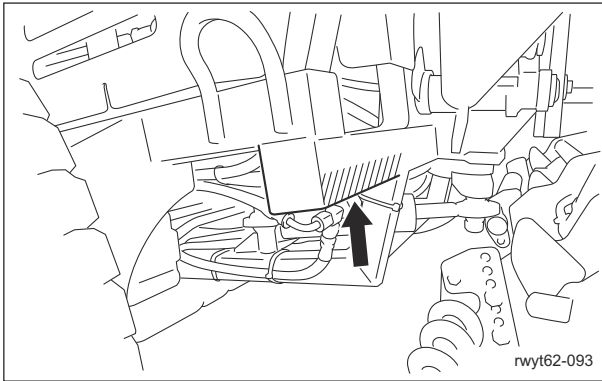

Jack-up Points\_002

### 2. Front left frame

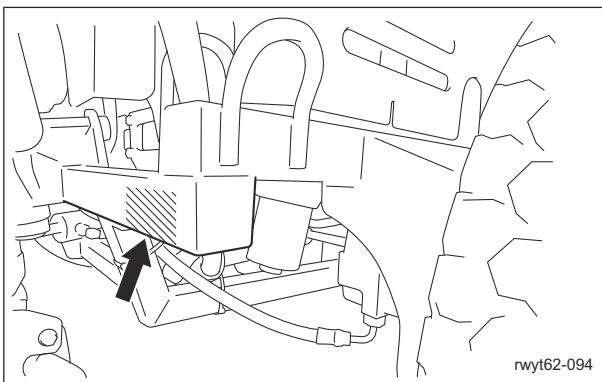

Jack-up Points\_003

### 3. Rear right frame

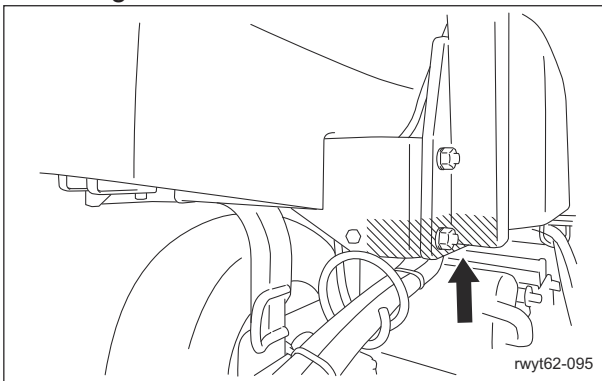

Jack-up Points\_004

### 4. Rear left frame

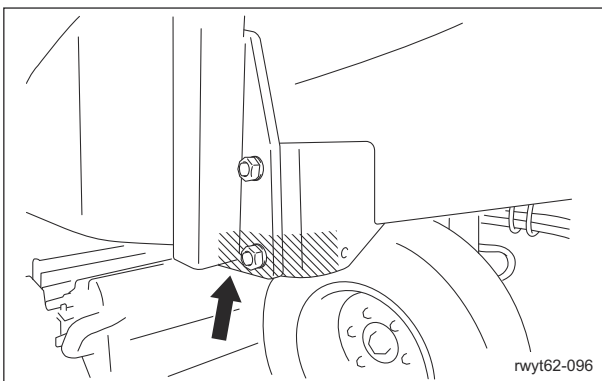

Jack-up Points\_005

## Hoisting The Machine

### About Hoisting The Machine

**Caution**

Hoist the machine on a level and stable place.

**Caution**

Remove the obstacles which may prevent safety operation before hoisting the machine.

**Caution**

Use appropriate hoists, crane and ropes.

**Caution**

Pay attention to the position of the center of gravity during hoisting to balance the machine sufficiently.

Unless the machine balanced sufficiently, it may fall and cause an accident resulting in injury or death.

**Caution**

When hoisting the machine, do not get on and do not get close to the machine carelessly.

**Important**

Hoisting the machine at any other point than the indicated points will result in damage to the frame or other parts.

**Important**

Be sure to use sufficiently strong wire ropes.

Use the specified hoisting points for hoisting the machine.

# Maintenance

## Lifting Points

**Important**

Be sure to use adequately strong cables.

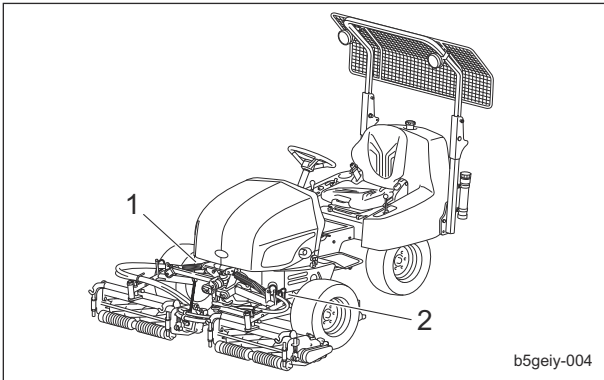

Lifting Points\_001

Lifting points	
1	Front right frame
2	Front left frame

### 1. Front right frame

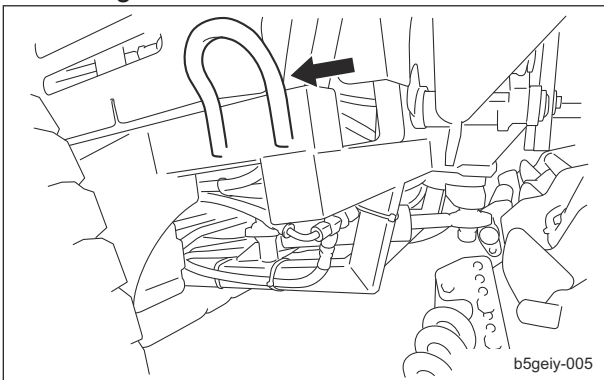

Lifting Points\_002

### 2. Front left frame

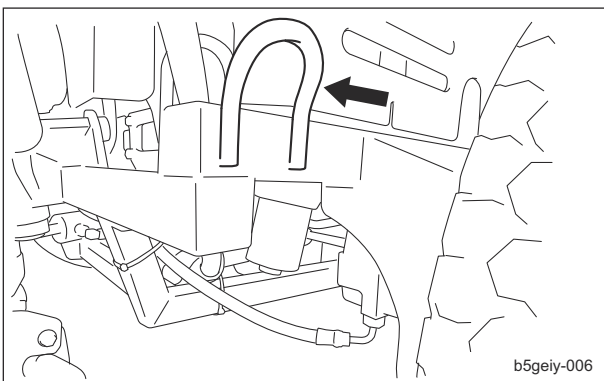

Lifting Points\_003

## Inspection and Cleaning

Inspect and clean the machine with the goals of the followings.

- Accident prevention
- Failure prevention
- Performance retention

Make efforts for early detection of the machine failure and prevention of the sudden occurrence of trouble.

Perform maintenance and repair works immediately if any abnormality is found in the machine.

## Engine

### Cleaning of Fuel Filter

1. Close the fuel cock on fuel filter.

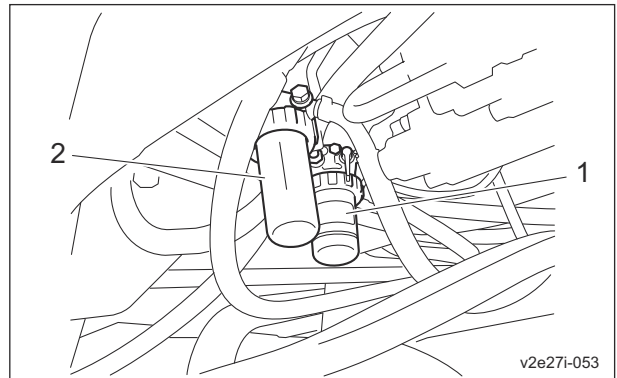

Cleaning of Fuel Filter\_001

1	Water separator
2	Fuel filter

2. Remove the retaining ring and then remove the cup.

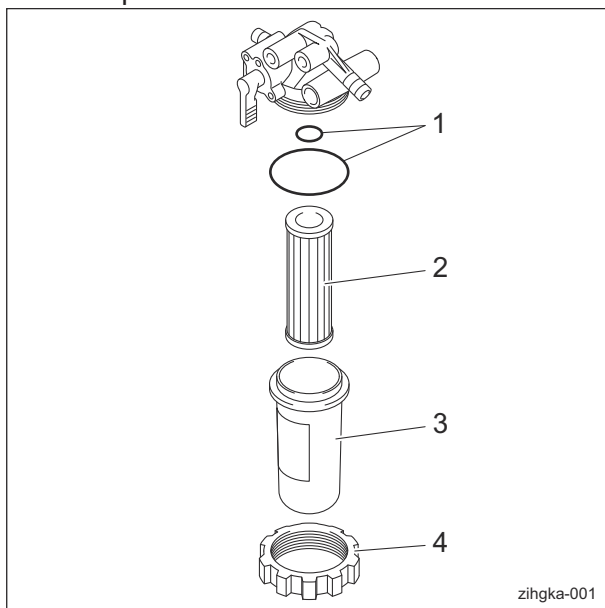

Cleaning of Fuel Filter\_002

1	O-ring
2	Element
3	Cup
4	Retaining ring

3. Soak the filter element in diesel fuel and clean it.  
4. Clean inside of the filter cup with diesel fuel.

**Important**

While installing, be careful that it is not contaminated with dirt or dust. If the fuel is contaminated with dirt or dust etc., the fuel injection pump and injection nozzle will become worn.

5. Install the fuel filter and put the parts back together.  
6. Fill up the fuel tank with fuel and open the fuel cock.

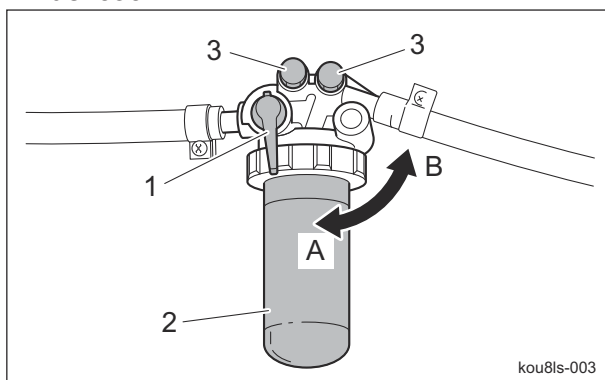

Cleaning of Fuel Filter\_003

1	Fuel cock
2	Fuel filter
3	Air-bleeding plug
A	ON (Open)
B	OFF (Close)

7. Turn the key switch to the "ON" position. When the fuel pump is activated, the cup will be filled with fuel and air bleeding will occur automatically.  
8. Switch the ignition key to the "START" position and remove air out of the fuel line.  
9. If the engine does not start within 15 seconds after switching the ignition key to the "START" position, wait at least 30 seconds, and then repeat the same operation.

## Inspection of Water Separator

**Important**

Water-contaminated fuel may impair engine startability, decrease output or damage engine parts.

1. Make sure that the water separator is not damaged or dirty.  
2. Make sure that there is no water leakage.  
3. Make sure that debris and water have not accumulated in the cup.  
With the float raised, water contamination is confirmed.  
When the float reaches the drain level, drain the water.

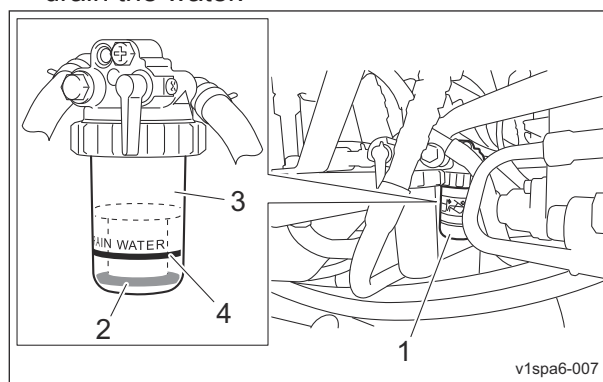

Inspection of Water Separator\_001

1	Water Separator
2	Float
3	Cup
4	Drain level

# Maintenance

## Draining of Water Separator

### Important

Water contamination in the fuel may decrease the engine starting performance and power output and may result in breakage of engine parts.

Drain water from the water separator according to the maintenance schedule. And drain water whenever the float is raised by water.

1. Stop the engine, and then turn the key switch to the "OFF" position.
2. Place a container under the water separator.
3. Close the fuel filter cock.
4. Close the fuel cock of water separator.

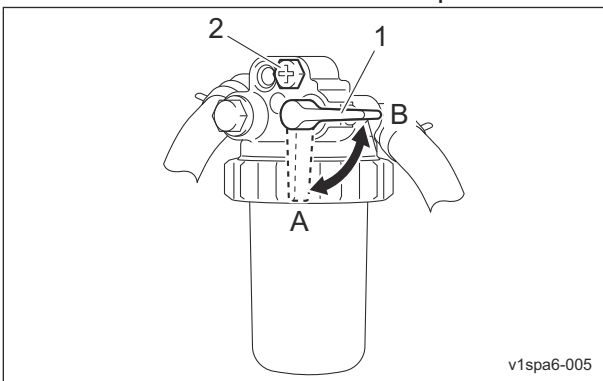

Draining of Water Separator\_001

1	Fuel cock
2	Air-bleeding plug
A	ON (Open)
B	OFF (Close)

5. Remove the retaining ring and then remove the cup.

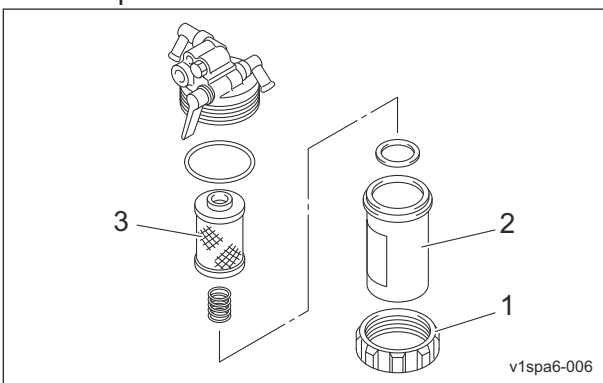

Draining of Water Separator\_002

1	Retaining ring
2	Cup
3	Element

6. Discharge water from the cup.

### Important

When installed, be careful that it is not contaminated with dirt or dust. If the fuel is contaminated with dirt or dust etc., the fuel injection pump and injection nozzle will become worn.

7. Put the parts back together.
8. Fill up the fuel tank with fuel and open the fuel cock.
9. Open the fuel cock of water separator.

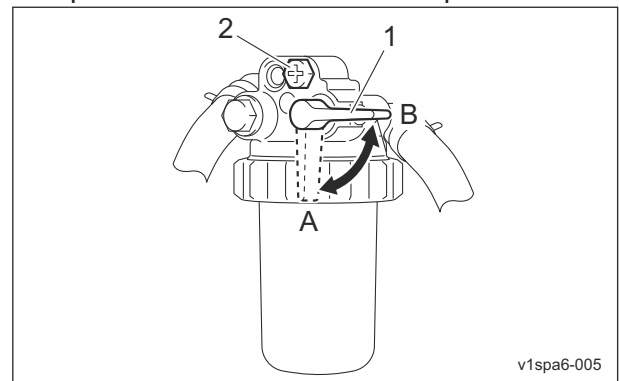

Draining of Water Separator\_003

1	Fuel cock
2	Air-bleeding plug
A	ON (Open)
B	OFF (Close)

10. Loosen the air-bleeding plug by one turn.
11. Set the ignition key to the "ON" position. After the fuel pump operated, the cup becomes filled with fuel and air bleeding occurs automatically.
12. Turn the key to the "START" position and remove air out of the fuel line.
13. In the case that there are still air bubbles in the fuel from air-bleeding plug even after 15 seconds or more pass after setting the ignition key to "START", pause for 30 seconds or more and then repeat the same steps.
14. Tighten the air-bleeding plug.

## Cleaning of Water Separator

**Important**

Water contamination in the fuel may decrease the engine starting performance and power output and may result in breakage of engine parts.

Clean the water separator according to the maintenance schedule.

And clean it whenever debris has accumulated in the cup.

1. Stop the engine, and then turn the ignition key to the "OFF" position.
2. Place a container under the water separator.
3. Close the fuel filter cock.
4. Close the fuel cock of water separator.

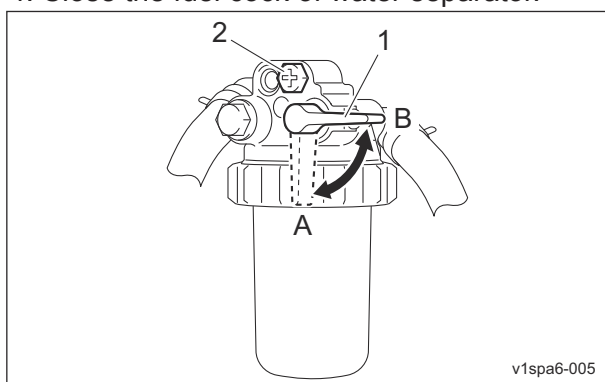

Cleaning of Water Separator\_001

1	Fuel cock
2	Air-bleeding plug
A	ON (Open)
B	OFF (Close)

5. Remove the retaining ring and then remove the cup.

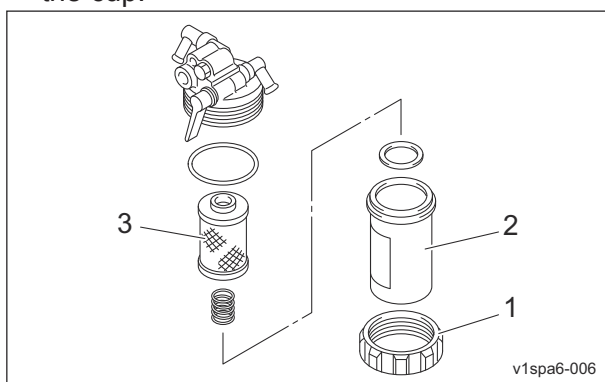

Cleaning of Water Separator\_002

1	Retaining ring
2	Cup
3	Element

6. Discharge water from the cup.
7. Clean the cup and element with light oil. Replace the element with new one as necessary.

**Important**

When installed, be careful that it is not contaminated with dirt or dust.

If the fuel is contaminated with dirt or dust etc., the fuel injection pump and injection nozzle will become worn.

8. Put the parts back together.
9. Fill up the fuel tank with fuel and open the fuel cock.
10. Open the fuel cock of water separator.

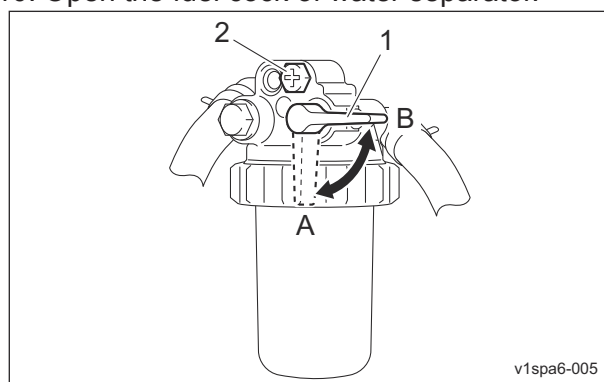

Cleaning of Water Separator\_003

1	Fuel cock
2	Air-bleeding plug
A	ON (Open)
B	OFF (Close)

11. Loosen the air-bleeding plug by one turn.
12. Set the ignition key to the "ON" position. After the fuel pump operated, the cup becomes filled with fuel and air bleeding occurs automatically.
13. Turn the key to the "START" position and remove air out of the fuel line.
14. In the case that there are still air bubbles in the fuel from air-bleeding plug even after 15 seconds or more pass after setting the ignition key to "START", pause for 30 seconds or more and then repeat the same steps.
15. Tighten the air-bleeding plug.

# Maintenance

## Cleaning of Air Cleaner Element

A contaminated air cleaner element may cause malfunction of the engine.

To maximize the life of the engine, clean the air cleaner properly.

1. Unclip at two locations to remove the air cleaner cap.
2. Remove the air cleaner filter.
3. While paying close attention not to damage the air cleaner filter, tap a solid portion of the air cleaner filter or blow compressed air from its inside to remove dust and dirt. If the air cleaner filter is extremely contaminated, replace it with a new one.
4. Attach the air cleaner filter to the air cleaner body.
5. Attach the air cleaner cap, and then fix it securely with the clips.

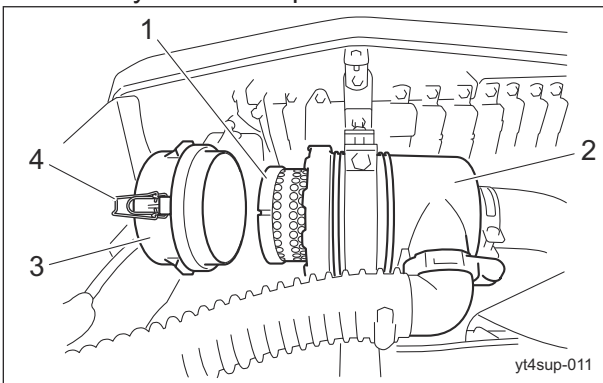

Cleaning of Air Cleaner Element\_001

1	Air cleaner filter
2	Air cleaner body
3	Air cleaner cap
4	Clip

## Inspection of Belt

### Warning

The engine must be stopped when the belt is inspected.

### Warning

If you have removed the cover during inspection, make sure that you replace it in the original position securely. If the cover remains removed, the operator or the mechanic may come in contact with the rotating objects or belt, possibly resulting in injuries.

### Important

A slacking or damaged belt or damaged fan may cause overheating or lack of a battery charge.

1. Press the middle of the belt with your finger to check the belt tension.
2. Make sure that there are no cracks, damage or abnormal wear.

## Main Vehicle

### Inspection of Hydraulic Hoses and Pipes

### Warning

When checking the hydraulic circuit for pinhole leaks or oil leakage from nozzles, do not use your hands. Use items such as paper or corrugated cardboard to find leakage points.

Be extremely careful with high-pressure oil as it may pierce your skin, resulting in personal accidents.

If fluid is injected into the skin it must be surgically removed within a few hours by a doctor familiar with this form of injury or gangrene may result.

1. Make sure that there is no wear, deterioration or damage in the hydraulic hoses and pipes.
2. Make sure that there is no looseness in the connecting portion of the hydraulic hoses and pipes.
3. Check underneath the machine for hydraulic oil leakage.

## Inspection of Belts

**Warning**

Be sure to stop the engine before inspecting the belts.

**Warning**

If you have removed any covers, etc., during inspection, make sure that you securely re-attach them in their original positions. If covers, etc., remain removed, the operator or the mechanic may come into contact with rotating parts or belts, and foreign objects may fly off, possibly resulting in injuries.

1. Press the middle of the belt with your finger to check the belt tension.
2. Make sure that there are no cracks, damage or abnormal wear.

## Inspection of Electrical Wiring

**Important**

Electrical short circuit will cause fire, electrical leakage and malfunction of electrical equipments.

1. Make sure that there is no defacement in wires and terminals.
2. Make sure that there is no deterioration or damage in wires and terminals.
3. Make sure that there is no looseness in wiring connections.
4. Make sure that there is no poor terminal connection.

## Inspection of Wheel Mounting Bolt

**Important**

Tighten the wheel mounting bolts on the specified torque by using a torque wrench.

1. Check the wheel mounting bolts and wheel nuts for looseness and coming off.
2. Check the wheel mounting bolts and wheel nuts for cracks and damages.
3. Check the wheel mounting bolts and wheel nuts for rust.
4. Check around the wheel mounting bolts and wheel nuts for traces of rust fluid.

5. Check the wheel mounting bolts for unequal bolt length.
6. Check the wheel mounting bolts and wheel nuts for stripped threads and abrasion.

**Supplying Fluids****Engine**

## Supply of Engine Oil

**Important**

Do not supply too much engine oil. Otherwise, the engine may be damaged.

**Important**

Do not mix different types of engine oil.

**Important**

Be sure to use engine oil that is classified as API Service Grade CF or higher, with an SAE Viscosity that is appropriate for the operating environment (ambient temperature).

**Important**

Securely install the oil level gauge and oil filler cap.

If the engine oil level is lower than the lower limit on the oil level gauge, supply engine oil. Supply engine oil through the oil filler port.

1. Place the machine to set the engine on the level.
2. Stop the engine.
3. Remove the oil filler cap.

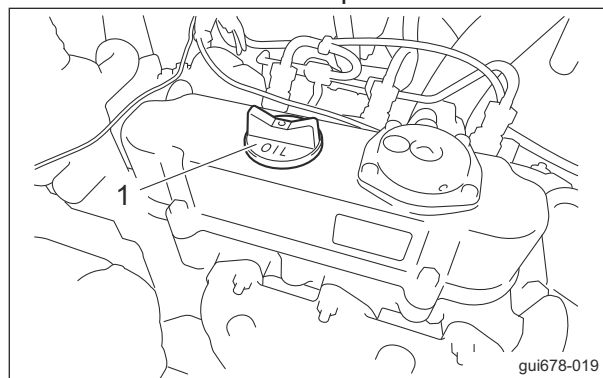

Supply of Engine Oil\_001

1	Oil filler cap
---	----------------

# Maintenance

4. Supply new engine oil through the oil filler port.  
Supply until the oil reaches a level in between the upper and lower limit lines on the oil level gauge.
5. Securely install the oil filler cap.
6. It will take a while for the supplied engine oil to descend into the oil pan.  
Check the oil level again 10 to 20 minutes after supplying the engine oil.  
If the engine oil level is low, supply oil again until it reaches the specified level.

## Supply of Coolant

### ⚠ Caution

Do not touch the radiator or coolant during engine operation or immediately after the engine has been turned off. Otherwise, you may get burned due to high temperatures.

### ⚠ Caution

Supply coolant after the engine has well cooled down.

### ⚠ Caution

The radiator cap is pressurized. If you remove the radiator cap while the engine is overheated, hot steam will burst out, possibly resulting in burns. Make sure that the water temperature and pressure are reduced, and then grab the cap with a thick cloth and gradually open the cap.

### Important

When you supply coolant, be sure to mix clean water and antifreeze (long-life coolant), and then pour it into the radiator and reserve tank.

### Important

Tightly close the radiator cap. If the cap is loose or incorrectly installed, the engine will be overheated due to water leakage, resulting in engine damage.

When mixing antifreeze and clean water, refer to "Relationship between concentration of long-life coolant (LLC) and freezing temperature" below for the mixing ratio.  
Relationship between concentration of long-life coolant (LLC) and freezing temperature

Freezing temperature	LLC concentration (volume %)
Down to -10 °C (14 °F)	20 %
Down to -15 °C (5 °F)	30 %
Down to -20 °C (-4 °F)	35 %
Down to -25 °C (-13 °F)	40 %

If the coolant level in the reserve tank is low, supply clean water and antifreeze.

1. If the coolant level in the reserve tank is lower than the "LOW" mark, follow the steps below to supply coolant.
  - [1] Remove the reserve tank cap.
  - [2] Supply clean water and antifreeze up to the "FULL" mark in the reserve tank.
  - [3] Install the reserve tank cap.

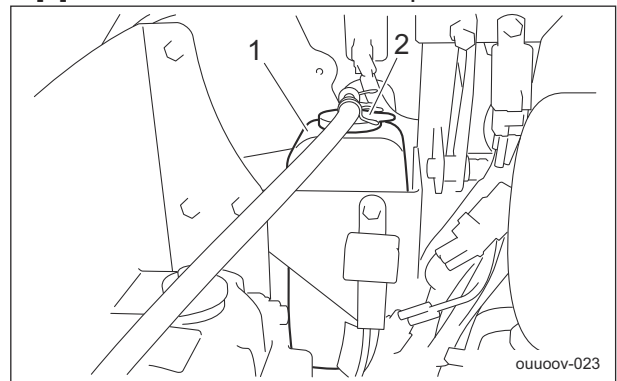

Supply of Coolant\_001

1	Reserve tank
2	Reserve tank cap

2. If no coolant is in the reserve tank, follow the steps below to supply coolant.
  - [1] Remove the radiator cap.
  - [2] Supply clean water and antifreeze up to the opening of the radiator.
  - [3] Install the radiator cap.
  - [4] Remove the reserve tank cap.
  - [5] Supply clean water and antifreeze up to the "FULL" mark in the reserve tank.
  - [6] Install the reserve tank cap.

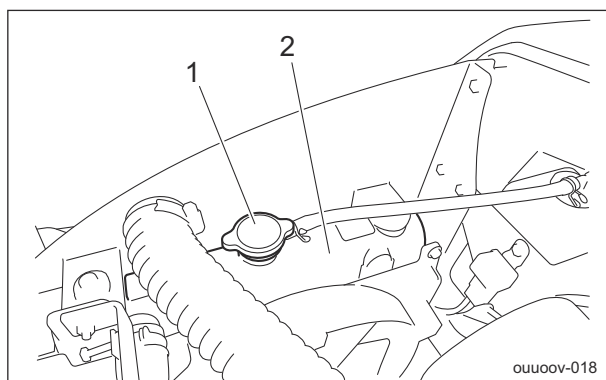

Supply of Coolant\_002

1	Radiator cap
2	Radiator

## Main Vehicle

### Supply of Hydraulic Oil

#### Important

Do not mix different types of oil.

#### Important

For the hydraulic oil to be used, consult Characteristics of Hydraulic Oil and use the oil whose characteristics are equivalent or superior to those specified there. Especially regarding kinematic viscosity and viscosity index, use of hydraulic oil whose figures are less than those of the specified hydraulic oil will cause a malfunction in the hydraulic circuit.

#### ■ Characteristics of Hydraulic Oil

ISO Viscosity Grade		ISO VG46
Density	15 °C (59 °F)	0.873 g/cm <sup>3</sup> (0.0315 lb/in <sup>3</sup> )
API Gravity		30.6
Flash Point (Open Cup)		230 °C (446 °F)
Pour Point		-30 °C (-22 °F)
Kinematic	40 °C (104 °F)	46 mm <sup>2</sup> /s (46 cSt)
Viscosity	100 °C (212 °F)	7 mm <sup>2</sup> /s (7 cSt)
Viscosity Index		109

#### ■ Characteristics of Hydraulic Oil with conditions of use

Hydraulic oil of ISO viscosity grade VG68 can be used only if the following condition is met:

- The outside temperature must be 20 °C (68 °F) or more during engine operation.

ISO Viscosity Grade		ISO VG68
Density	15 °C (59 °F)	0.878 g/cm <sup>3</sup> (0.0318 lb/in <sup>3</sup> )
API Gravity		29.7
Flash Point (Open Cup)		252 °C (486 °F)
Pour Point		-30 °C (-22 °F)
Kinematic	40 °C (104 °F)	68 mm <sup>2</sup> /s (68 cSt)
Viscosity	100 °C (212 °F)	9 mm <sup>2</sup> /s (9 cSt)
Viscosity Index		107

#### Note:

In Japan, "Shell Tellus S2M46 (ISO VG46)" and "Shell Tellus S2M68 (ISO VG68)" meet the characteristics described above.

However, in other countries, the specification of Shell Tellus S2M46 and Shell Tellus S2M68 can be below what is required.

Please check the product data sheet to ensure that it meets the requirements before using.

#### 1. Remove the rear cover.

"Procedure to Remove/Install Rear Cover" (Page 5-3)

#### 2. If the hydraulic oil level is low, follow the steps below to supply oil.

■ #10001 - 10278

[1] Open the tank cap.

[2] Supply hydraulic oil through the oil filling port until the oil level reaches the middle of the oil gauge on the hydraulic tank.

[3] Tighten the tank cap securely.

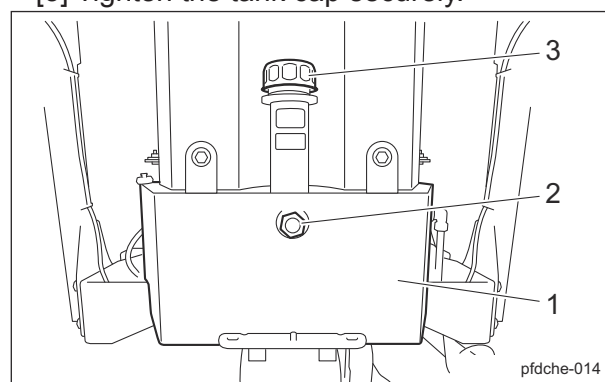

Supply of Hydraulic Oil\_001

1	Hydraulic tank
2	Oil gauge
3	Tank cap

# Maintenance

## ■ #10279-

- [1] Loosen the bushing with a wrench and remove the oil filler plug.
- [2] Supply hydraulic oil through the oil filling port until the oil level reaches the middle of the oil gauge on the hydraulic tank.
- [3] Install the oil filler plug and tighten the bushing securely.

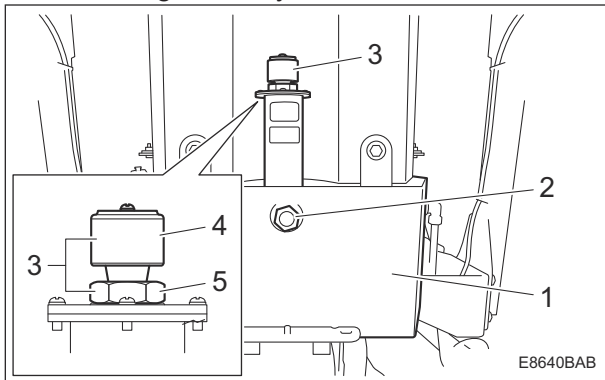

Supply of Hydraulic Oil\_002

1	Hydraulic tank
2	Oil gauge
3	Oil filler plug
4	Air breather
5	Bushing

3. Start the engine, and then repeat the steps below a few times.
  - Raise and lower the mower units.
  - Turn the steering wheel left and right.
  - Move forward and reverse.
4. Lower the mower units and maintain that position on a level surface, and then check to see if the oil level is at the middle of the oil gauge.  
If the hydraulic oil level is low, supply oil again until it reaches the specified level.
5. Check underneath the machine for hydraulic oil leakage.
6. Install the rear cover.

## Supply of Battery Fluid

### **⚠ Danger**

If battery fluid comes into contact with eyes, it may result in blindness. Immediately flush with plenty of water and take medical care from an ophthalmologist.

### **⚠ Danger**

Do not drink battery fluid.  
If battery fluid enters the mouth or is swallowed, it may result in burns inside the mouth. Immediately and repeatedly gargle with plenty of water, then drink plenty of water, and take medical care.

### **⚠ Danger**

When you supply battery fluid, wear protective garments and safety glasses, etc.

### **⚠ Warning**

If battery fluid adheres to the skin or clothing, it may cause burns or damage clothing. Immediately flush with plenty of water, then wash thoroughly with soap.

### **⚠ Warning**

Do not allow the battery fluid level to become lower than the LOWER LEVEL (minimum fluid level line).  
The battery may explode if it is used or charged while the battery fluid level is at the LOWER LEVEL (minimum fluid level line).

### **⚠ Warning**

When refilling, do not fill purified water above the UPPER LEVEL (maximum fluid level line). Doing so may result in electrolyte leaks.

### **⚠ Caution**

Implement after the engine and muffler etc. have well cooled down.  
Otherwise, you may get burned.

### **Important**

If battery fluid adheres to the vehicle, it may cause corrosion.  
Wipe it off with a cloth dampened with water, and then flush with water.

If the battery fluid level is lower than halfway between the UPPER LEVEL (maximum fluid level line) and LOWER LEVEL (minimum fluid level line), add purified water.

1. Loosen the vent plug and remove it.

2. Add purified water up to the UPPER LEVEL (maximum fluid level line)
3. Tighten the vent plug securely.

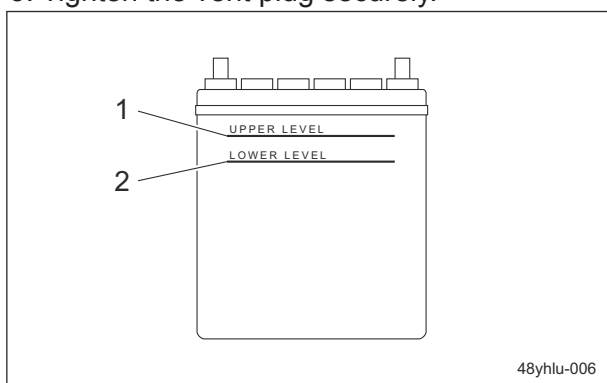

48yhtu-006

Supply of Battery Fluid\_001

1	Maximum fluid level line
2	Minimum fluid level line

## Greasing

### About Greasing

Since there may be adhesion or damage due to lack of grease on moving parts, they must be greased.

Add urea-based No. 2 grease in accordance with the Maintenance Schedule.

Other locations where the specified grease or lubricant is used are indicated in "Greasing Points".

Add grease using the specified grease or lubricant.

### Greasing Points

Grease nipples are installed in the following locations.

Add grease every 50 hours of operation. If specified locations, periods and grease are additionally described below, follow the instructions.

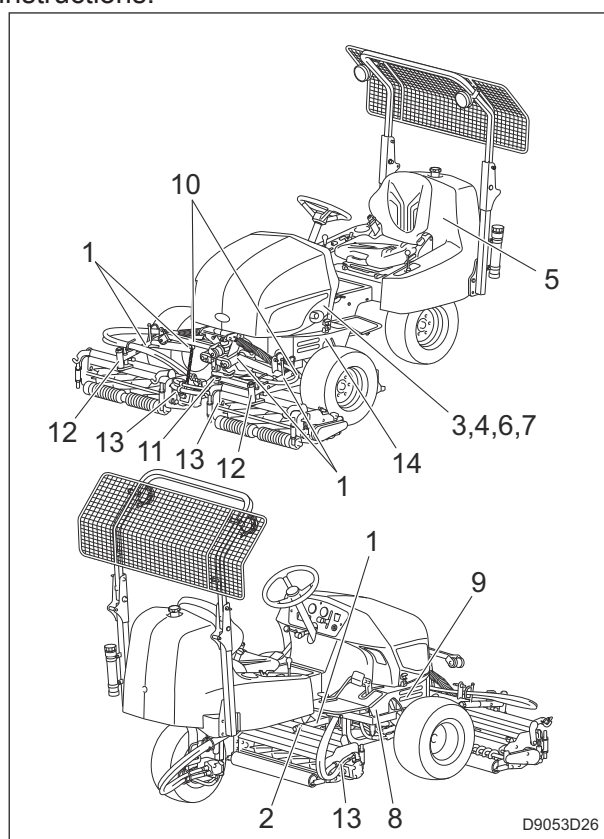

D9053D26

Greasing Points\_001

	Location	No. of greasing points
1	Lift arm fulcrum	5
2	Mower arm fulcrum	1
3	Brake pedal shaft fulcrum	1
4	Brake lever shaft	1
5	Rear wheel housing	1
6	Tension lever	1
7	Neutral cam lever	1
8	Traveling pedal shaft fulcrum	1
9	Traveling pedal relay lever	1
10	Front wheel brake lever	2
11	Mower lift cam lever	1
12	Mower coupling	2
13	Reel motor shaft	3
14	Piston pump shaft	1

# Maintenance

## 1. Lift arm fulcrum

Mower unit #1

There is one greasing point on the lift arm fulcrum connected to the mower unit.

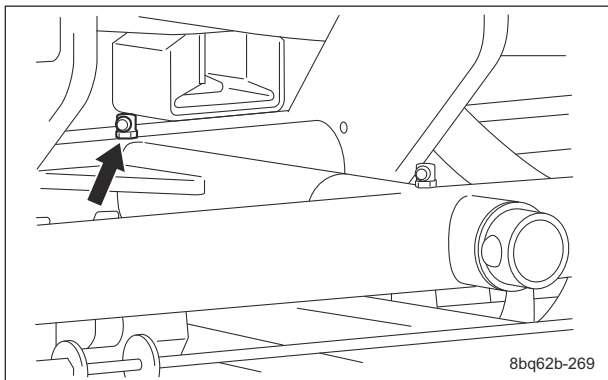

Greasing Points\_002

Mower units #2 and #3

There are two greasing points on the lift arm fulcrum connected to each mower unit.

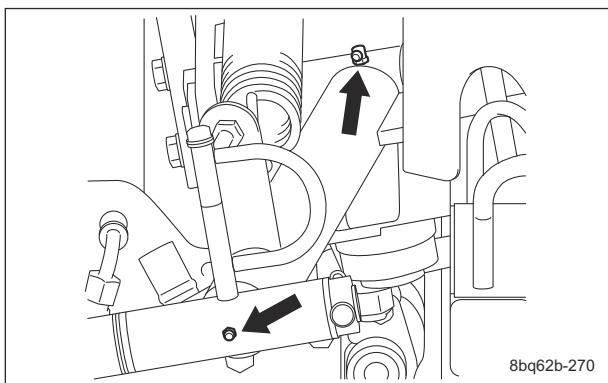

Greasing Points\_003

## 2. Mower arm fulcrum

Mower unit #1

There is one greasing point on the mower arm fulcrum.

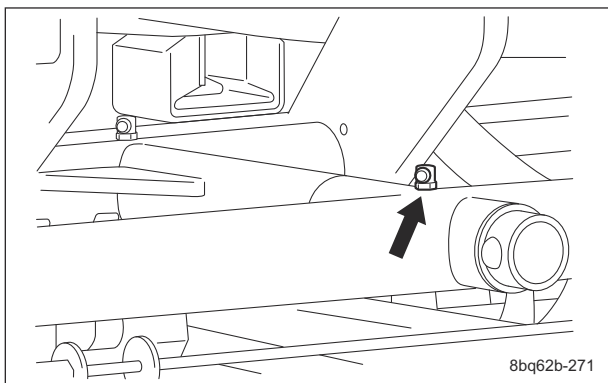

Greasing Points\_004

## 3. Brake pedal shaft fulcrum

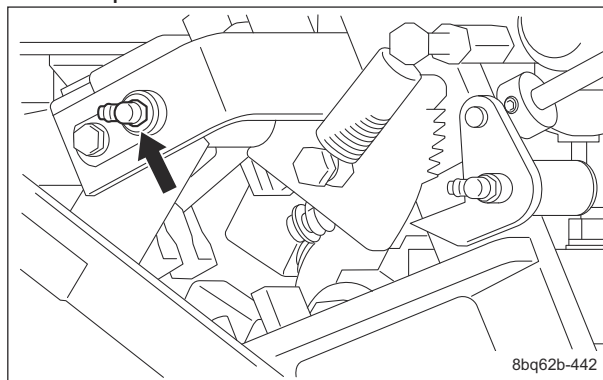

Greasing Points\_005

## 4. Brake lever shaft

Add grease every 100 hours of operation or every year, whichever comes earlier.

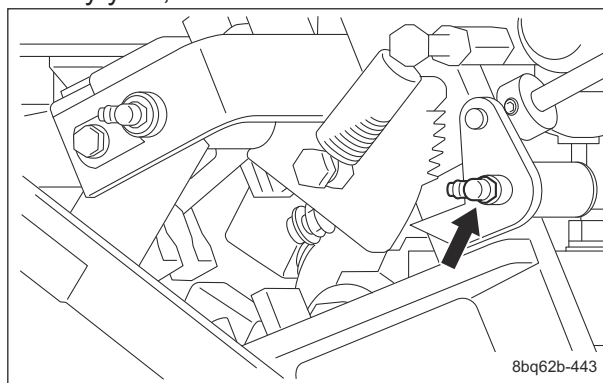

Greasing Points\_006

## 5. Rear wheel housing

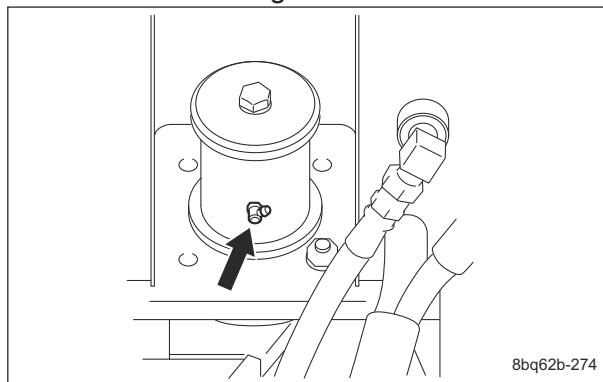

Greasing Points\_007

## 6. Tension lever

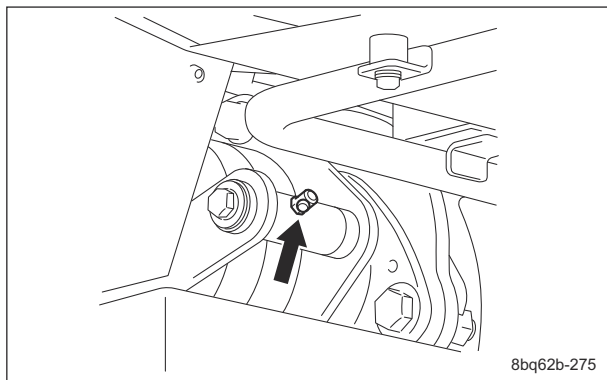

Greasing Points\_008

## 7. Neutral cam lever

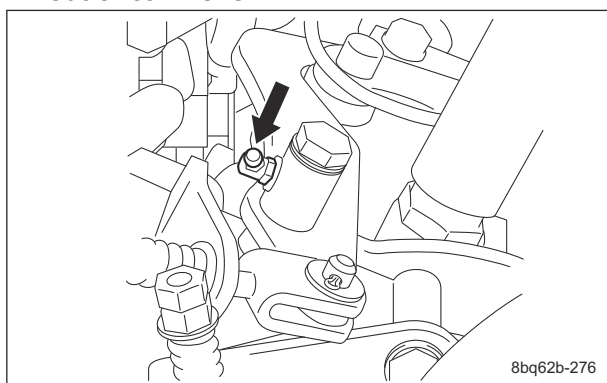

Greasing Points\_009

## 8. Traveling pedal shaft fulcrum

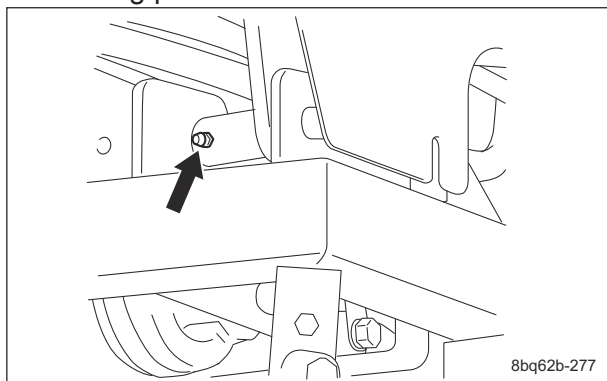

Greasing Points\_010

## 9. Traveling pedal relay lever

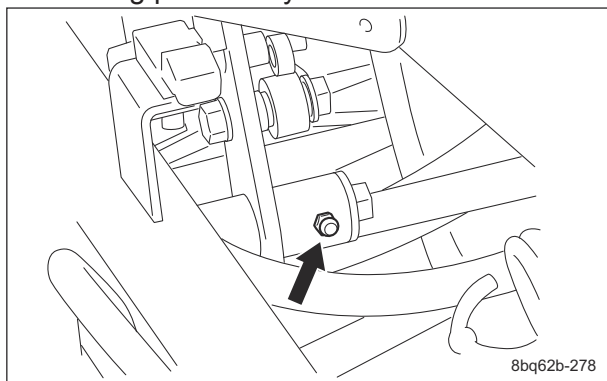

Greasing Points\_011

## 10. Front wheel brake lever

There is one greasing point each on the left and right sides.

Left side

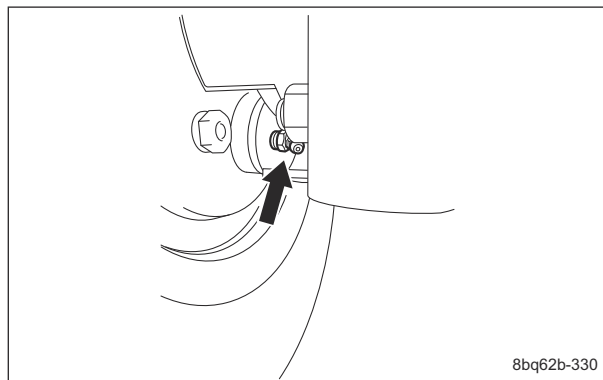

Greasing Points\_012

Right side

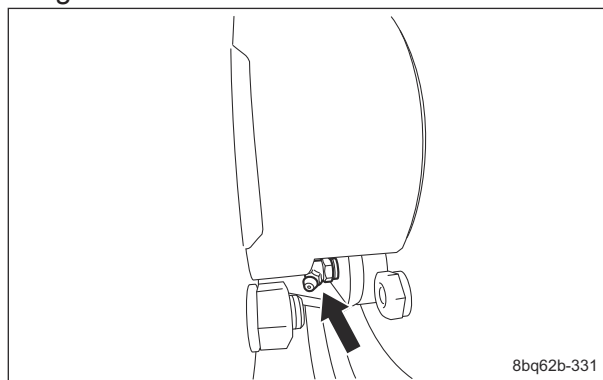

Greasing Points\_013

## 11. Mower lift cam lever

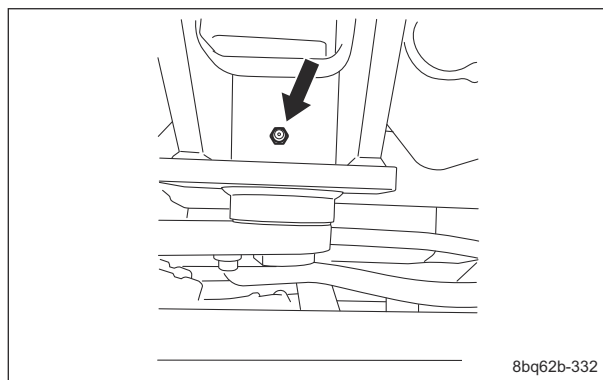

Greasing Points\_014

# Maintenance

## 12. Mower coupling

Mower unit #2 and #3

There is one greasing point each on the couplings connecting the mower units.

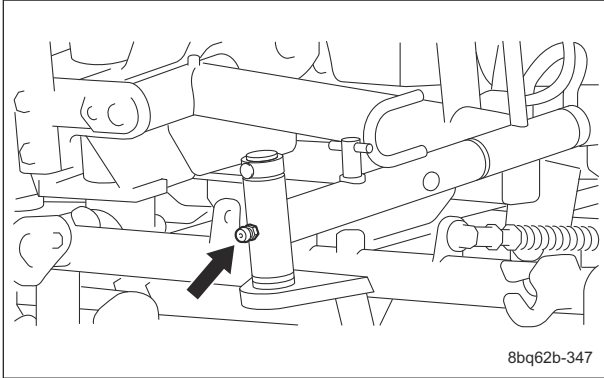

Greasing Points\_015

## 13. Reel motor shaft

Apply 2 g (0.004 lb) of MOLY SPEED GREASE NO.2 to the reel motor shaft mounted on each mower unit every 250 hours.

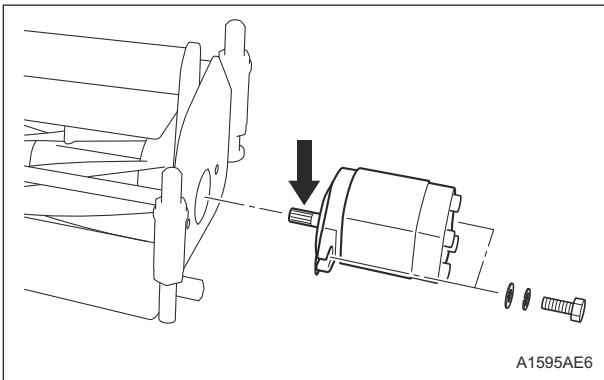

Greasing Points\_016

## 14. Piston pump shaft

### Important

Add grease to the piston pump shaft after loosening the air-bleeding bolt located under the pump shaft housing for 2 turns. Failure to perform the air-bleeding will be unable to add the grease.

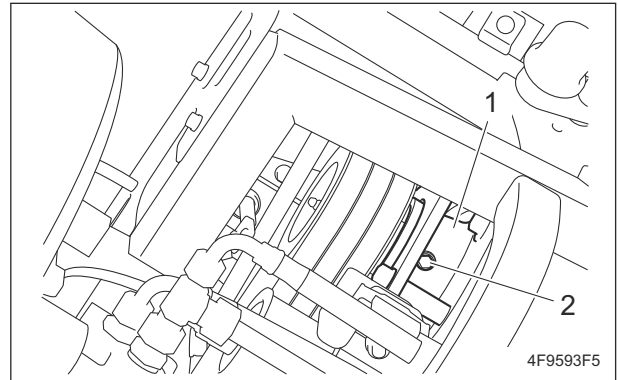

Greasing Points\_017

1	Pump shaft housing
2	Air-bleeding bolt

Apply 5 g (0.01 lb) of MOLY SPEED GREASE NO.2 to the piston pump shaft every year.

Note:

A Bentone grease formulated with molybdenum disulfide that has excellent wear resistance and anti-seizure properties. Little dripping at high temperature.

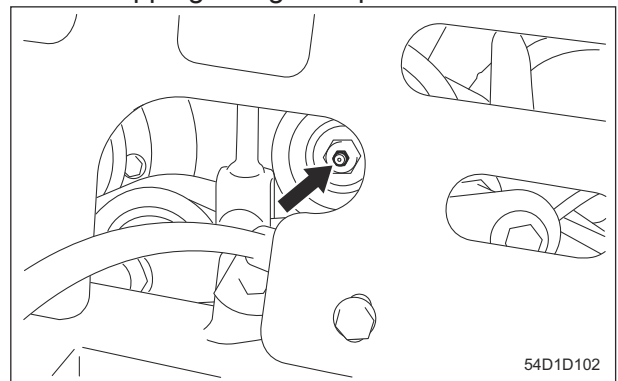

Greasing Points\_018

## Lubrication

### About Lubrication

It is necessary to lubricate moving parts so that they will not become stuck or damaged. The locations where lubricant is used are indicated in "Lubricating Points". Apply the lubricant.

### Lubricating Points

Apply lubricant at the following locations every 50 hours of operation.

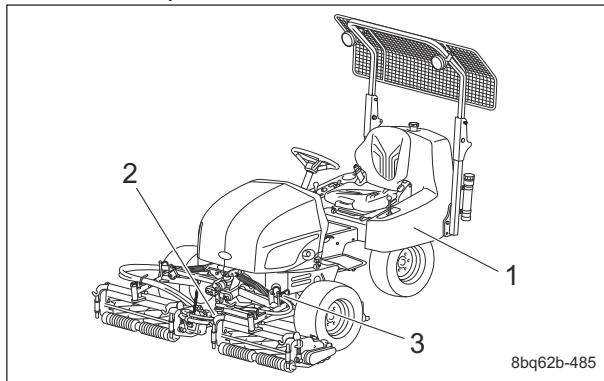

Lubricating Points\_001

	Location	No. of greasing points
1	Steering cylinder spherical bearing	2
2	Front mower cylinder spherical bearing	2
3	Rear mower cylinder spherical bearing	1

1. Steering cylinder spherical bearing  
There are two locations.

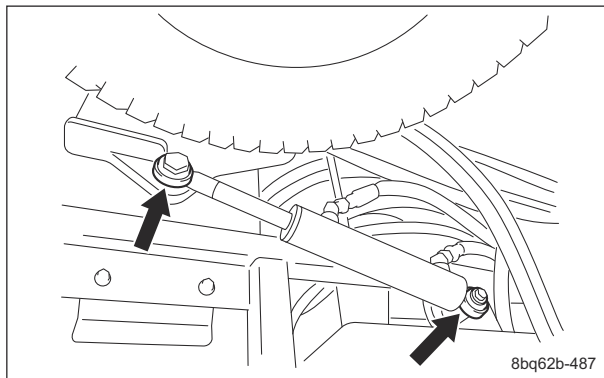

Lubricating Points\_002

2. Front mower cylinder spherical bearing  
There are two locations.

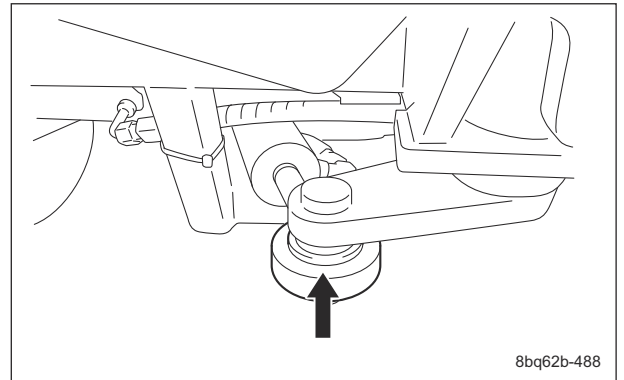

Lubricating Points\_003

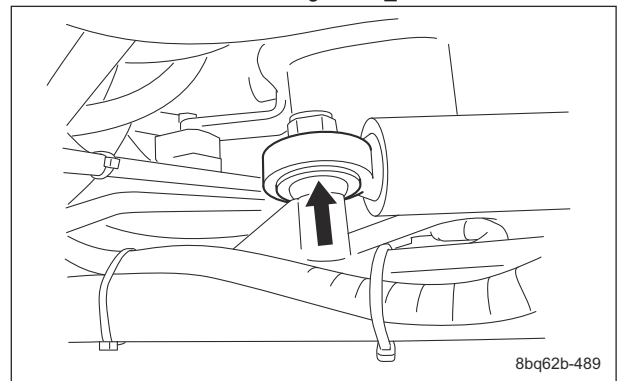

Lubricating Points\_004

3. Rear mower cylinder spherical bearing  
There is one location.

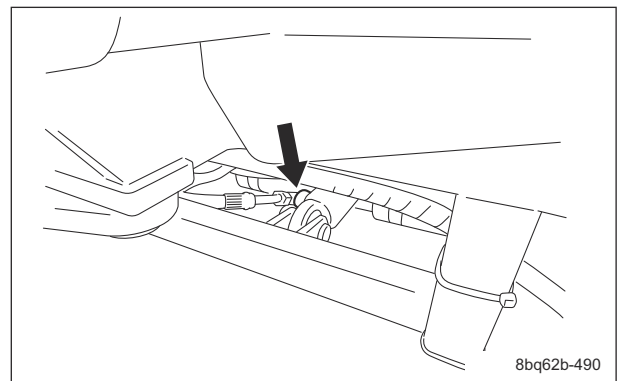

Lubricating Points\_005

# Maintenance

## Adjustment

### Engine

#### Adjustment of Fan Belt

#### Warning

Be sure to stop the engine before inspecting or adjusting the fan belt.

#### Warning

If a cover is removed due to inspection or adjustment, be sure to reinstall it in its original location.

#### Important

A slacking or damaged fan belt will cause overheating or lack of battery charge. Adjust or replace the belt.

For fan belt adjustment, follow either of the methods below.

1. Adjustment on the basis of belt slack deviation when applying a specified load to a specified place

- [1] Press the middle of the belt with your finger to check the belt tension. The belt tension is appropriate when the belt slacks by approximately 10 mm (0.39 in) when you apply a force of 98 N (10 kgf) to the belt at the middle point between the pulleys.
- [2] If the belt tension is incorrect, loosen bolt A, nut and bolt B for securing the alternator, and then move the alternator to adjust the tension.
- [3] Be sure to tighten bolt A, nut and bolt B securely after adjustment.

[4] After adjustment of belt tension, check the belt tension again.

If the belt tension is still not at the appropriate value after repeating the adjustment several times, replace the belt with a new one.

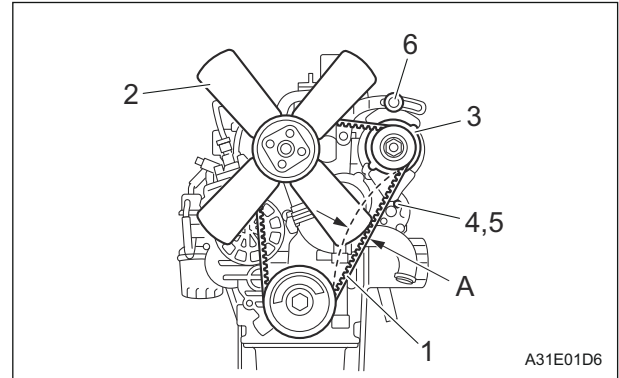

Adjustment of Fan Belt\_001

1	Fan Belt
2	Blade
3	Alternator
4	Bolt A
5	Nut
6	Bolt B
A	10 mm (0.39 in)

2. Adjustment to suitable belt tension force by using sonic type tension meters at a specified point

#### Important

Perform correct measurement in accordance with the operations manual of the equipment being used for tension measurement.

#### Important

Perform measurement immediately after mounting the belt, when the pulley is not rotating.

- [1] Measure belt tension force by using a sonic type tension meter. For measurement position and distance between pulleys, see diagram below. Here is the suitable belt tension force.

Adjustment	200 – 300 N (20.39 - 30.59 kgf)
Replacement	267 – 361 N (27.23 - 36.81 kgf)

- [2] If the belt tension is inappropriate, loosen bolt A, nut and bolt B for securing the alternator, and then move the alternator to adjust the tension.

[3] Be sure to tighten bolt A, nut and bolt B securely after adjustment.

[4] After adjustment of belt tension, check the belt tension again.

If the belt tension is still not at the appropriate value after repeating the adjustment several times, replace the belt with a new one.

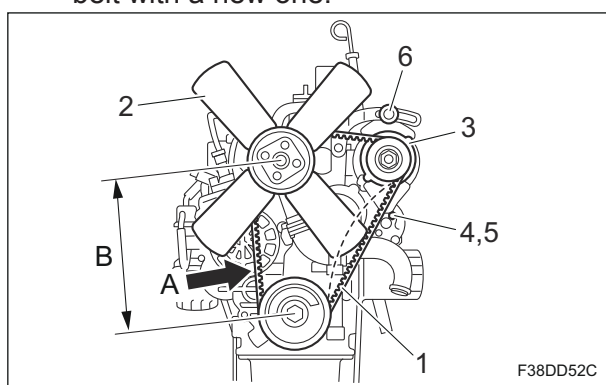

Adjustment of Fan Belt\_002

1	Fan belt
2	Blade
3	Alternator
4	Bolt A
5	Nut
6	Bolt B
A	Measurement position
B	Distance between pulleys

## Main Vehicle

### Adjustment of Belt Tension

#### Warning

Be sure to stop the engine before adjusting the belts.

#### Important

For the specified value of belt tension, refer to Adjusted Values. Before making sure of belt tension, rotate the belt several times.

#### ■ Adjustment of Hydraulic Pump Drive Belt

1. Open the hood.

2. Check the belt tension.

The criterion for belt tension is that the spring length of the adjuster is approximately 30 - 35 mm (1.18 - 1.38 in).

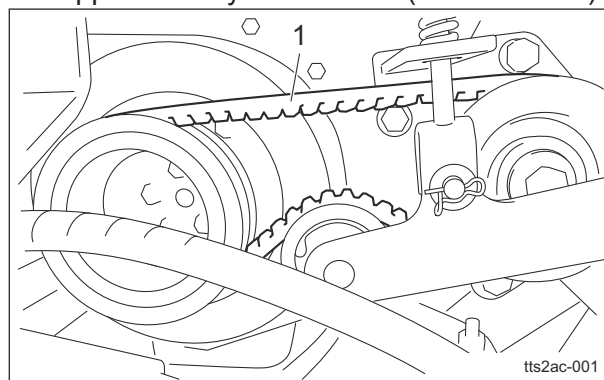

Adjustment of Hydraulic Pump Drive Belt\_001

1	Hydraulic pump drive belt
---	---------------------------

3. If the belt tension is not at the approximate value, adjust the length of the spring.

[1] Loosen the lock nut.

[2] Turn the nut to adjust the length of the spring.

[3] Fix with the lock nut.

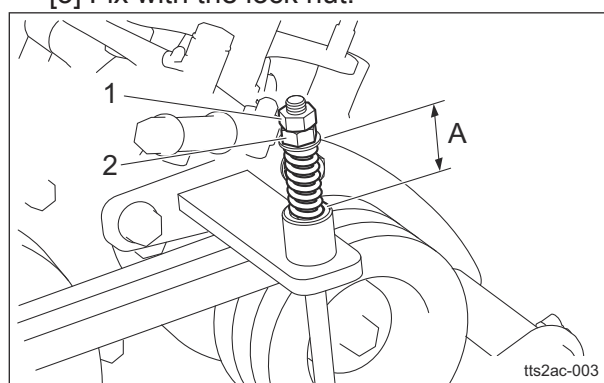

Adjustment of Hydraulic Pump Drive Belt\_002

1	Lock nut
2	Nut
A	30 - 35 mm (1.18 - 1.38 in)

4. After adjustment of belt tension, check the belt tension again.

If the belt tension is still not at the approximate value after repeating the adjustment several times, replace the belt with a new one.

5. Close the hood.

# Maintenance

## Adjustment of Lift Arm Spring

**Important**

Adjust the spring if the front wheels slip on an ascending slope.

1. Raise the mower units.
2. Adjust the length of the lift arm spring with lock nut A and lock nut B.  
Increasing the length of the spring will improve the hill-climbing ability.
3. Perform the same procedure for the lift arm springs of both left and right mower units.  
Make an adjustment so that the lift arm spring will be compressed evenly.

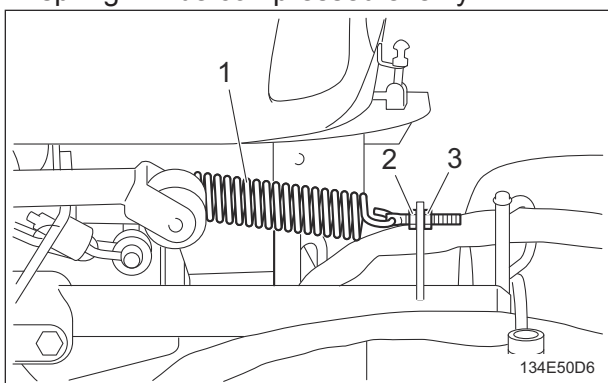

Adjustment of Lift Arm Spring\_001

1	Lift arm spring
2	Lock nut A
3	Lock nut B

## Adjustment of Mower Stopper Pin

**Note:**

Depending on the specifications, this function may not be available.

The mower stopper pin can prevent or allow tilting of the mower units.

Adjust according to the operating conditions.

**Fixed:**

- The mowing line while traveling straight ahead is a straight line. (The mowing line is easy to see.)
- The mower units do not tilt while operating on slopes, and incomplete mowing can be reduced.

**Released:**

- It is appropriate when turning while mowing or it is easy to follow undulations.

1. With the machine on a level surface, lower all mower units.

2. Apply the parking brake, and then stop the engine.

3. Adjust the position of the mower stopper pin, and then insert the cotter pin.

**To fix:**

Insert the cotter pin into the upper hole in the mower stopper pin.

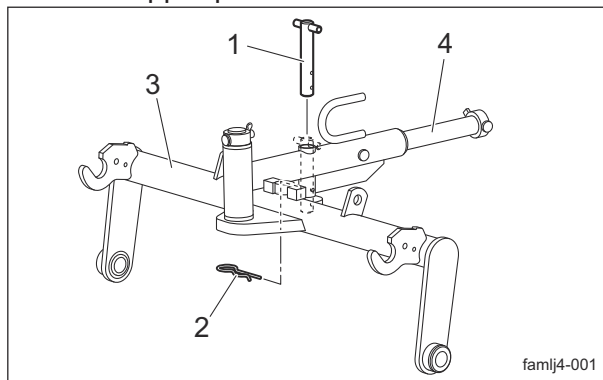

Adjustment of Mower Stopper Pin\_001

1	Mower stopper pin
2	Cotter pin
3	Mower arm
4	Mower coupling

**To release:**

Insert the cotter pin into the lower hole in the mower stopper pin.

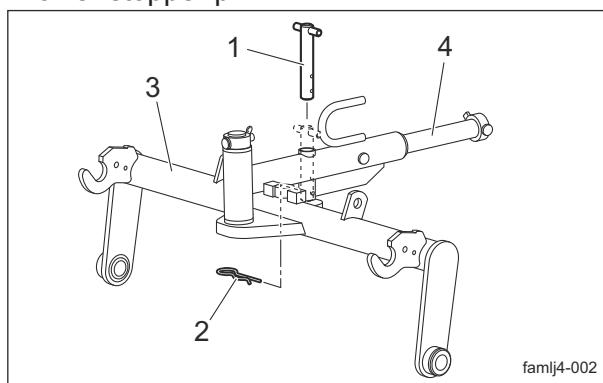

Adjustment of Mower Stopper Pin\_002

1	Mower stopper pin
2	Cotter pin
3	Mower arm
4	Mower coupling

## Adjustment of Mower Stabilizer (LH Unit)

## Note:

Depending on the specifications, this function may not be available.

## Important

After adjusting the cutting height, adjust the mower stabilizer.

The mower stabilizer stabilizes the mower units and prevents an undulating finish (a phenomenon called Marcelling).

1. Lower all mower units on a level place.
2. Apply the parking brake, and then stop the engine.
3. Loosen the lock nut.
4. Tighten the nut to adjust the length of the spring (compression).
  - Mower #2 and #3: 140 mm (5.51 in)
  - Mower #1: 60 mm (2.36 in)
5. Tighten the lock nut.

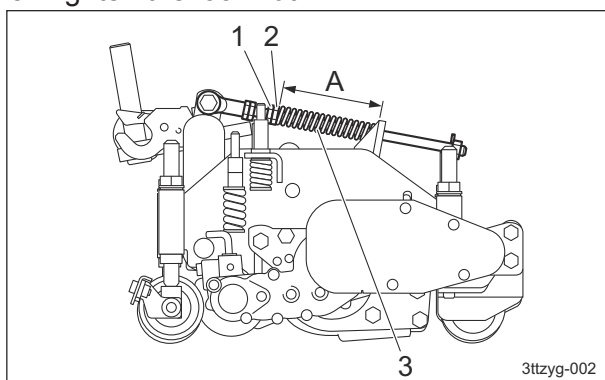

Adjustment of Mower Stabilizer (LH Unit)\_001

1	Lock nut
2	Nut
3	Spring
A	Mower #2 and #3: 140 mm (5.51 in) Mower #1: 60 mm (2.36 in)

3. Start the engine.
4. On a level surface, raise all mower units.
5. Apply the parking brake.
6. Stop the engine.
7. Tighten the nuts of the left and right mower stoppers in a position where the mower unit is leveled and the mower arm contacts the mower stoppers.

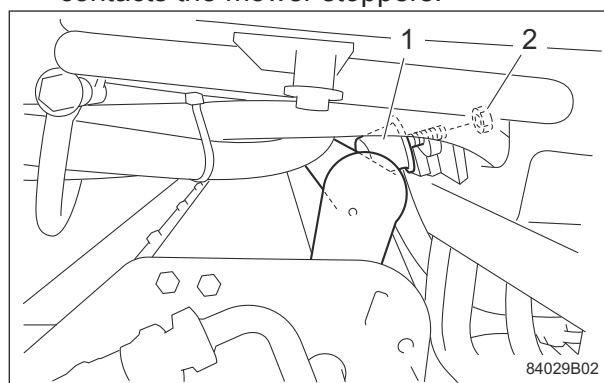

Adjustment of Mower Stoppers for Mower Unit #1\_001

1	Mower stopper
2	Nut

## Adjustment of Mower Stopper

#### ■ Adjustment of Mower Stoppers for Mower Unit #1

The mower stopper is installed to prevent the mower unit from interfering with the frame.

1. Loosen the nuts of the left and right mower stoppers.
2. Place the left and right mower stoppers to the highest position and attach them temporarily.

## Replacement

### Engine

#### Replacement of Engine Oil

#### ⚠ Caution

Be careful with hot oil, which could cause burns if it contacts your skin.

#### Important

When changing the engine oil, be sure to drain it into a container and discard it in accordance with local laws and regulations.

#### Important

Be sure to use engine oil that is classified as API Service Grade CF or higher, with an SAE Viscosity that is appropriate for the operating environment (ambient temperature).

#### Important

Securely install the oil level gauge and oil filler cap.

Change the engine oil more frequently if it is contaminated and especially if you use the machine in dusty areas or operate the engine at high loads or in high temperatures.

1. Follow the steps below to remove the old engine oil.
  - [1] Start and run the engine to warm up the engine oil.
  - [2] Place the machine to set the engine on the level.
  - [3] Stop the engine.
  - [4] Remove the drain plug, and then drain the old engine oil into a container.

- [5] Re-place the drain plug.

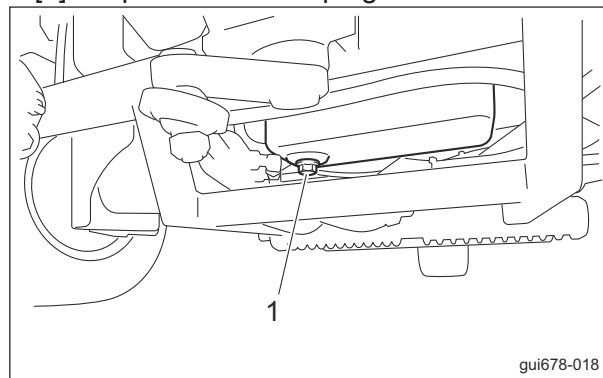

Replacement of Engine Oil\_001

1	Drain plug
---	------------

2. Remove the oil filler cap.
3. Supply new engine oil through the oil filler port until the oil reaches a level in between the upper and lower limit lines on the oil level gauge.  
Engine oil quantity is approximately 3.7 dm<sup>3</sup> (3.7 L).
4. Securely install the oil filler cap.

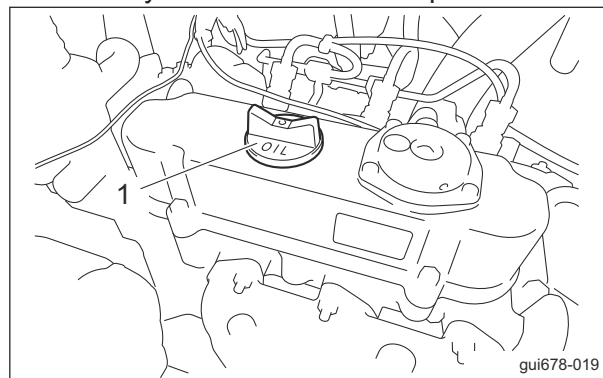

Replacement of Engine Oil\_002

1	Oil filler cap
---	----------------

5. It will take a while for the supplied engine oil to descend into the oil pan.  
Check the oil level again 10 to 20 minutes after supplying the oil.  
If the engine oil level is low, supply oil again until it reaches the specified level.
6. Check underneath the machine for oil leakage.

## Replacement of Engine Oil Filter

**Caution**

Be careful with hot oil, which could cause burns if it contacts your skin.

**Important**

When replacing the engine oil filter, be sure to drain the engine oil into a container and discard it in accordance with local laws and regulations.

**Important**

Be sure to use engine oil that is classified as API Service Grade CF or higher, with an SAE Viscosity that is appropriate for the operating environment (ambient temperature).

**Important**

Securely install the oil level gauge and oil filler cap.

1. With the filter wrench, remove the old filter cartridge.

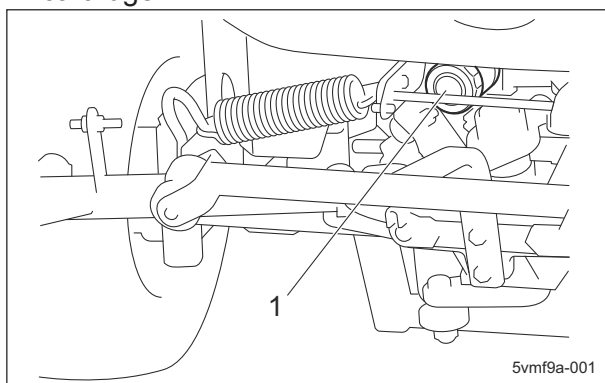

Replacement of Engine Oil Filter\_001

1	Filter cartridge
---	------------------

2. Lightly coat the packing of the new filter cartridge with engine oil.
3. Hand-tighten the filter cartridge until the packing contacts the sealing surface, and then firmly hand-tighten (without using a filter wrench).
4. Supply engine oil until it reaches the specified level.  
"Supply of Engine Oil" (Page 6-9)
5. Start the engine, and then stop it after 10 to 20 minutes.

6. Make sure that there is no oil leakage at the sealing surface of the filter cartridge.
7. Check the engine oil level.  
If it is low, supply engine oil until it reaches the specified level.

## Replacement of Fuel Filter Element

If dust or dirt accumulates in the fuel filter, the fuel flow will become insufficient. Replace the fuel filter at the appropriate times. The fuel filter is on the left side under the rear right of the seat.

1. Close the fuel cock of the fuel filter.

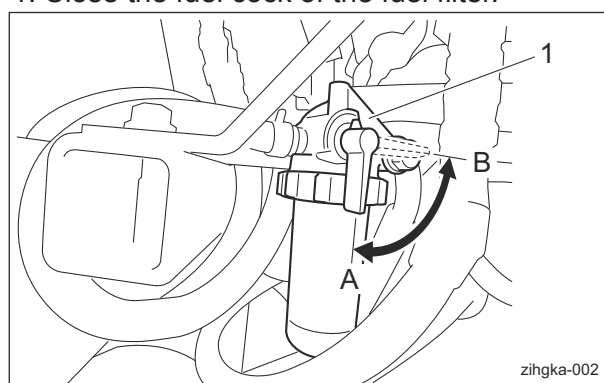

Replacement of Fuel Filter Element\_001

1	Fuel filter
A	ON (open)
B	OFF (close)

2. Remove the ring nut, and then remove the cup.

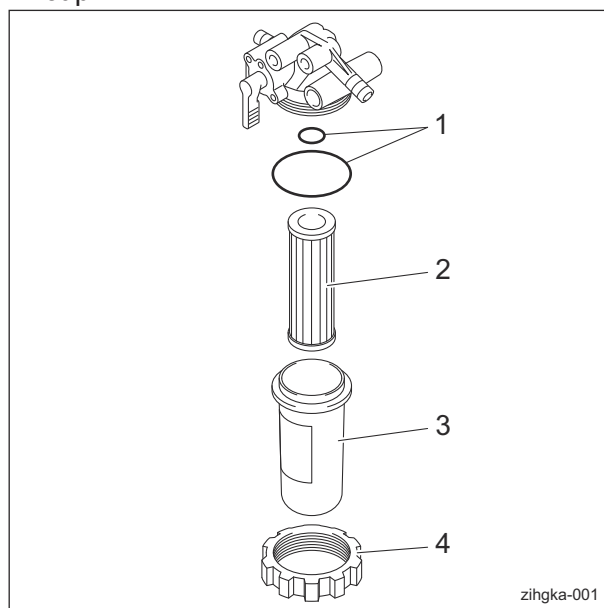

Replacement of Fuel Filter Element\_002

# Maintenance

1	O-ring
2	Element
3	Cup
4	Ring nut

3. Clean the inside of the filter cup with diesel fuel.

### Important

During installation, prevent contamination with dirt or dust.

If the fuel is contaminated with dirt or dust etc., the fuel injection pump and injection nozzle will become worn.

4. Install a new fuel filter element, and then correctly install all parts in their original positions.
5. Fill up the fuel tank with fuel, and then open the fuel cock.

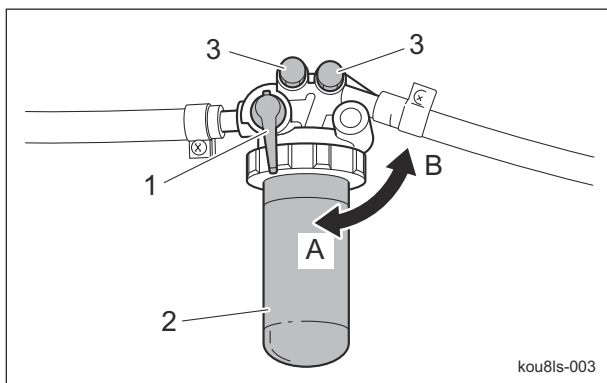

Replacement of Fuel Filter Element\_003

1	Fuel cock
2	Fuel filter
3	Air-bleeding plug
A	ON (open)
B	OFF (close)

### Note:

Air bleeding is not required since it occurs automatically.

## Replacement of Air Cleaner Element

### Important

A contaminated air cleaner element may cause malfunction of the engine.

1. The timing for replacing the air cleaner element is described below.

[1] Replace the air cleaner element in accordance with the Maintenance Schedule.

[2] If it is significantly contaminated, replace it, even if the hours of operation do not exceed the specified time.

2. Replace the air cleaner element by following the same steps as for cleaning the air cleaner element.

"Cleaning of Air Cleaner Element" (Page 6-8)

## Replacement of Coolant

**Caution**

Do not touch the radiator or coolant during engine operation or immediately after the engine has been turned off. Otherwise, you may get burned due to high temperatures.

**Caution**

Change coolant after the engine has well cooled down.

**Caution**

The radiator cap is pressurized. If you remove the radiator cap while the engine is overheated, hot steam will burst out, possibly resulting in burns. Make sure that the water temperature and pressure are reduced, and then grab the cap with a thick cloth and gradually open the cap.

**Important**

When changing the coolant, be sure to drain it into a container and discard it in accordance with local laws and regulations.

**Important**

When changing the coolant, be sure to mix clean water and antifreeze (long-life coolant), and then pour it into the radiator and reserve tank.

**Important**

Tightly close the radiator cap. If the cap is loose or incorrectly installed, the engine will be overheated due to water leakage, resulting in engine damage.

When mixing antifreeze and clean water, refer to "Relationship between concentration of long-life coolant (LLC) and freezing temperature" below for the mixing ratio.  
Relationship between concentration of long-life coolant (LLC) and freezing temperature

Freezing temperature	LLC concentration (volume %)
Down to -10 °C (14 °F)	20 %
Down to -15 °C (5 °F)	30 %
Down to -20 °C (-4 °F)	35 %
Down to -25 °C (-13 °F)	40 %

1. Stop the engine, and then allow the radiator to cool.
2. Open the hood.
3. Follow the steps below to drain the coolant.
  - [1] Position a container to drain the coolant into.
  - [2] Remove the drain plug from the radiator.

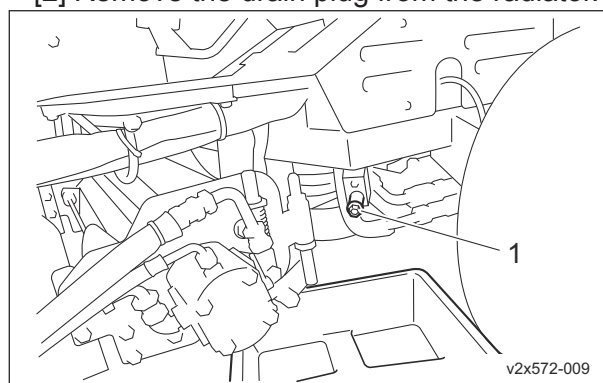

Replacement of Coolant\_001

1	Radiator drain plug
---	---------------------

- [3] Remove the radiator cap.

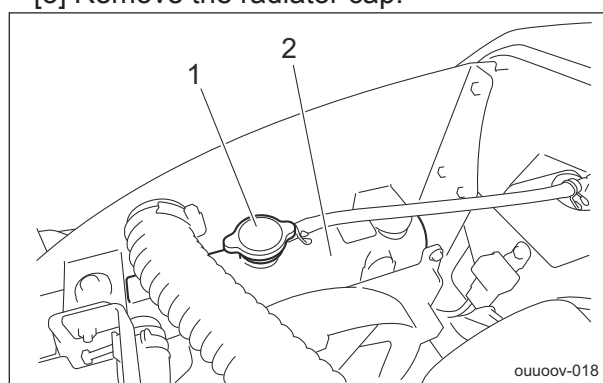

Replacement of Coolant\_002

1	Radiator cap
2	Radiator

# Maintenance

[4] Remove the reserve tank.

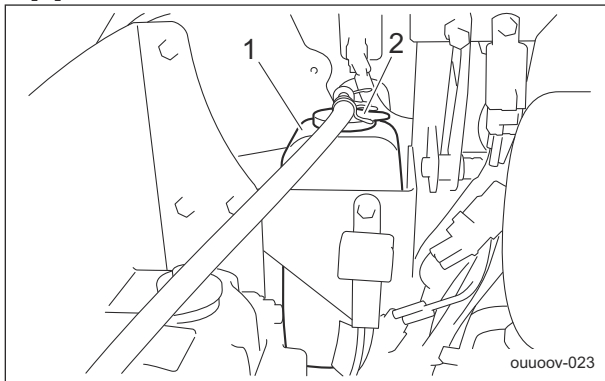

Replacement of Coolant\_003

1	Reserve tank
2	Reserve tank cap

[5] Remove the reserve tank cap, and then drain the coolant.

4. Install the reserve tank.
5. Clean the radiator with clean water to remove any debris or rust.
6. Drain all water from the radiator.
7. Follow the steps below to fill with coolant.  
The coolant quantity, including the reserve tank, is 3.1 dm<sup>3</sup> (3.1 L).
- [1] Install the drain plug.
- [2] Supply clean water and antifreeze into the radiator up to the radiator cap opening.
- [3] Install the radiator cap.
- [4] Supply clean water and antifreeze into the reserve tank up to the "FULL" mark.
- [5] Install the reserve tank cap.
8. Start the engine, and then idle for several minutes to bleed air from the system.
9. Stop the engine, and then allow the radiator to cool.
10. Check if the coolant level in the reserve tank is between "FULL" and "LOW", and then supply coolant if necessary.
11. Close the hood.

## Main Vehicle

### Replacement of Hydraulic Oil

#### ⚠ Caution

Be careful with hot oil, which could cause burns if it contacts your skin.

#### Important

When you change the hydraulic oil, be sure to drain it into a bowl and discard it in accordance with local laws and regulations.

#### Important

If the hydraulic oil emulsifies or if it becomes even slightly less transparent, change the oil immediately.

#### Important

For the hydraulic oil to be used, consult Characteristics of Hydraulic Oil and use the oil whose characteristics are equivalent or superior to those specified there. Especially regarding kinematic viscosity and viscosity index, use of hydraulic oil whose figures are less than those of the specified hydraulic oil will cause a malfunction in the hydraulic circuit.

#### ■ Characteristics of Hydraulic Oil

ISO Viscosity Grade		ISO VG46
Density	15 °C (59 °F)	0.873 g/cm <sup>3</sup> (0.0315 lb/in <sup>3</sup> )
API Gravity		30.6
Flash Point (Open Cup)		230 °C (446 °F)
Pour Point		-30 °C (-22 °F)
Kinematic Viscosity	40 °C (104 °F)	46 mm <sup>2</sup> /s (46 cSt)
	100 °C (212 °F)	7 mm <sup>2</sup> /s (7 cSt)
Viscosity Index		109

#### ■ Characteristics of Hydraulic Oil with conditions of use

Hydraulic oil of ISO viscosity grade VG68 can be used only if the following condition is met:

- The outside temperature must be 20 °C (68 °F) or more during engine operation.

ISO Viscosity Grade		ISO VG68
Density	15 °C (59 °F)	0.878 g/cm <sup>3</sup> (0.0318 lb/in <sup>3</sup> )
API Gravity		29.7
Flash Point (Open Cup)		252 °C (486 °F)
Pour Point		-30 °C (-22 °F)
Kinematic Viscosity	40 °C (104 °F)	68 mm <sup>2</sup> /s (68 cSt)
	100 °C (212 °F)	9 mm <sup>2</sup> /s (9 cSt)
Viscosity Index		107

**Note:**

In Japan, "Shell Tellus S2M46 (ISO VG46)" and "Shell Tellus S2M68 (ISO VG68)" meet the characteristics described above.

However, in other countries, the specification of Shell Tellus S2M46 and Shell Tellus S2M68 can be below what is required.

Please check the product data sheet to ensure that it meets the requirements before using.

1. Follow the steps below to remove the old oil.

[1] Start and run the engine to warm up the oil.

[2] On a level surface, lower the mower units, and then stop the engine.

[3] Remove the drain plug of the hydraulic tank and drain the old oil into a bowl.

[4] Wind new sealing tape on the drain plug, and then install the drain plug into the hydraulic tank.

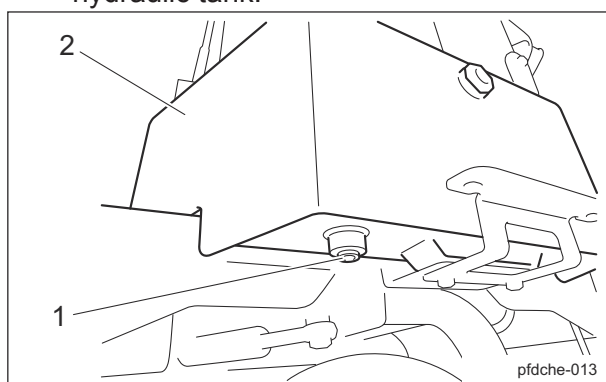

Replacement of Hydraulic Oil\_001

1	Drain plug
2	Hydraulic tank

2. Remove the rear cover.

"Procedure to Remove/Install Rear Cover"  
(Page 5-3)

3. Follow the steps below to supply new hydraulic oil.

The hydraulic tank capacity is approximately 26.0 dm<sup>3</sup> (26.0 L).

■ #10001 - 10278

[1] Open the tank cap.

[2] Supply hydraulic oil through the oil filling port until the oil level reaches the middle of the oil gauge on the hydraulic tank.

[3] Tighten the tank cap securely.

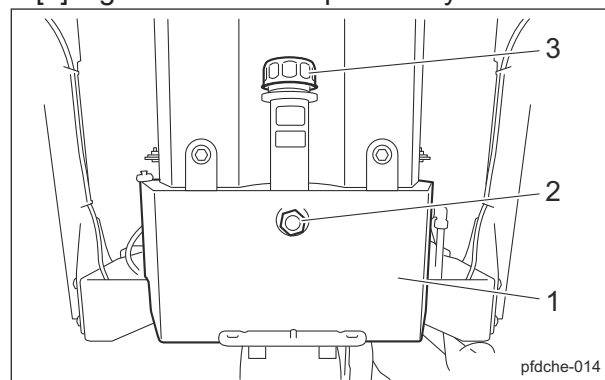

Replacement of Hydraulic Oil\_002

1	Hydraulic tank
2	Oil gauge
3	Tank cap

■ #10279-

[1] Loosen the bushing with a wrench and remove the oil filler plug.

[2] Supply hydraulic oil through the oil filling port until the oil level reaches the middle of the oil gauge on the hydraulic tank.

[3] Install the oil filler plug and tighten the bushing securely.

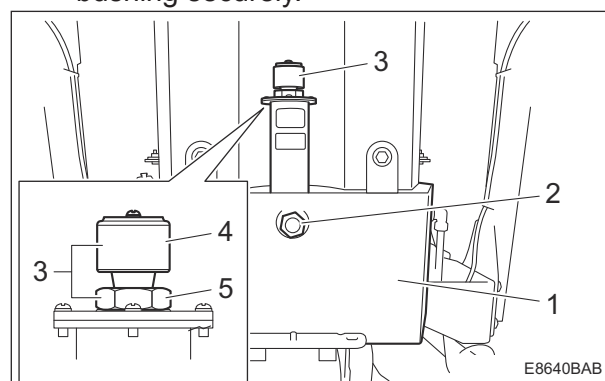

Replacement of Hydraulic Oil\_003

1	Hydraulic tank
2	Oil gauge
3	Oil filler plug
4	Air breather
5	Bushing

4. Start the engine, and then repeat the steps below a few times.

- Raise and lower the mower units.
- Turn the steering wheel left and right.
- Move forward and reverse.

# Maintenance

5. Lower the mower units and maintain that position on a level surface, and then check to see if the oil level is at the middle of the oil gauge.  
If the hydraulic oil level is low, supply oil again until it reaches the specified level.
6. Check underneath the machine for hydraulic oil leakage.
7. Install the rear cover.

## Replacement of Hydraulic Oil Filter

### ■ Replacement of Hydraulic Oil Line Filter

#### ⚠ Caution

Be careful with hot oil, which could cause burns if it contacts your skin.

#### Important

When replacing the hydraulic oil filter, be sure to drain the oil into a container and discard it in accordance with local laws and regulations.

#### Important

If the hydraulic oil emulsifies or if it becomes even slightly less transparent, change the oil immediately.

#### Important

Use hydraulic oil whose specification meets the requirements.

1. On a level surface, lower the mower units, and then stop the engine.
2. Loosen the filter case and remove it.

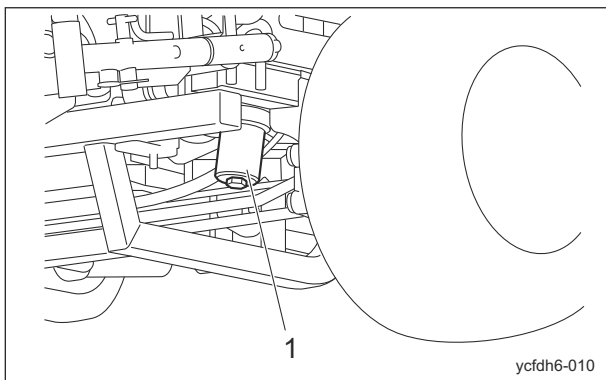

Replacement of Hydraulic Oil Line Filter\_001

1	Filter case
---	-------------

3. Remove the old filter cartridge.

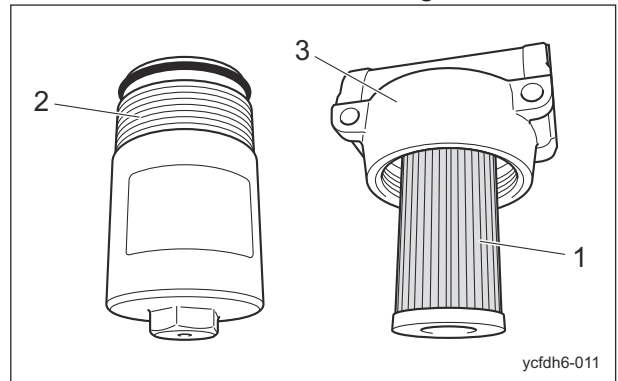

Replacement of Hydraulic Oil Line Filter\_002

1	Filter cartridge
2	Filter case
3	Body

4. Lightly coat the O-ring of the new filter cartridge with hydraulic oil, and then install the cartridge.

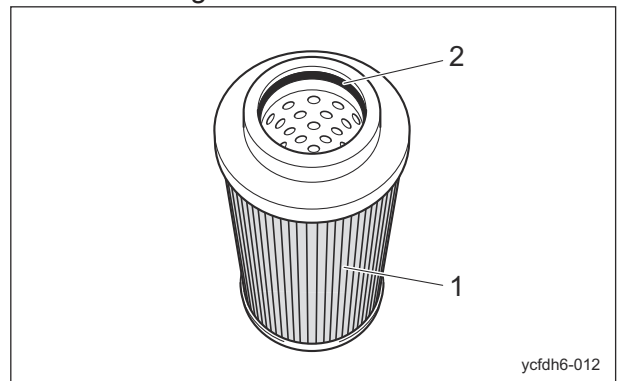

Replacement of Hydraulic Oil Line Filter\_003

1	Filter cartridge
2	O-ring

5. Clean the inside of the filter case.
6. Make sure that there is no damage to the O-ring of the filter case, and then lightly coat the O-ring with hydraulic oil.

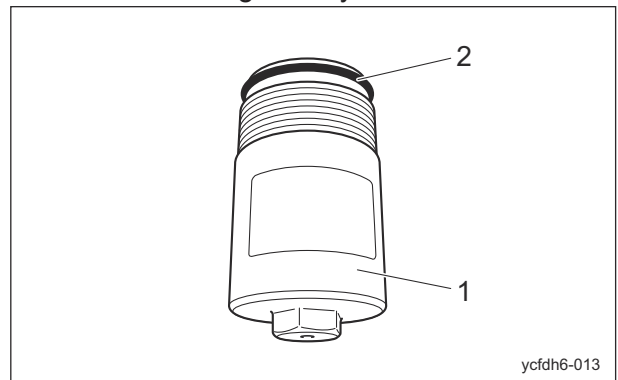

Replacement of Hydraulic Oil Line Filter\_004

1	Filter case
2	O-ring

7. Install the filter case onto the body, firmly hand-tighten it, and then tighten it to 25 to 35 N·m (254.93 - 356.90 kgf).

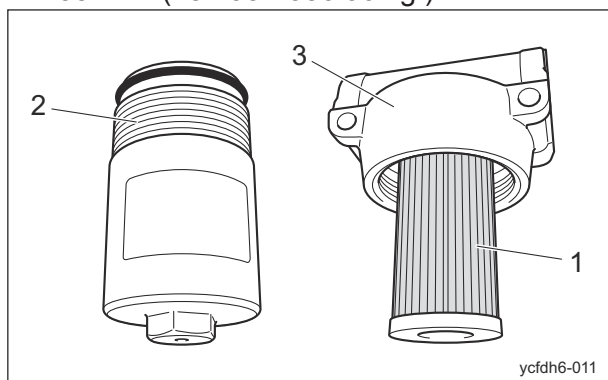

Replacement of Hydraulic Oil Line Filter\_005

1	Filter cartridge
2	Filter case
3	Body

8. Supply hydraulic oil until it reaches the specified level.  
"Supply of Hydraulic Oil" (Page 6-11)

#### Replacement of Air Breather Element

##### **Caution**

Be careful with hot oil, which could cause burns if it contacts your skin.

#10279-

1. Stop the engine on a flat surface.
2. Remove the rear cover.
3. Loosen the air breather screw and remove the seal washer.

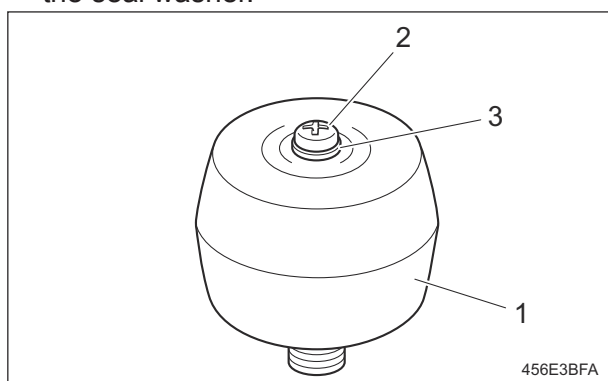

Replacement of Air Breather Element\_001

1	Air breather
2	Screw
3	Seal washer

4. Remove the top cover of the air breather.
5. Remove the old element.

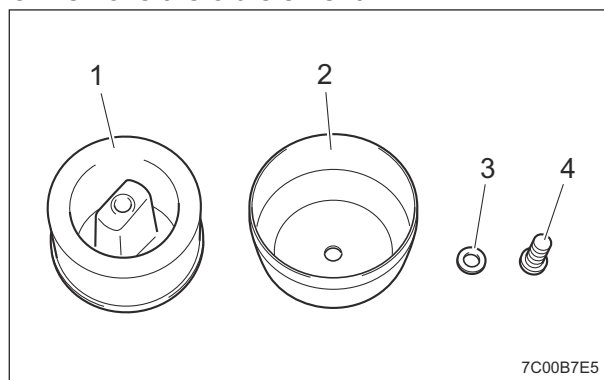

Replacement of Air Breather Element\_002

1	Element
2	Top cover
3	Seal washer
4	Screw

6. Install the new element.

##### **Important**

If the seal washer is damaged, replace it with a new one.

7. Install the top cover of the air breather.
8. Install the seal washer and tighten the screw.
9. Install the rear cover.

# Maintenance

## Replacement of Resin Bushing

Resin bushings are installed in the following locations.

Replace resin bushings according to the maintenance schedule.

### 1. Lift arm (Mower unit #2, #3)

Note:

The illustration shows the lift arm for mower unit #2.

■ LS66

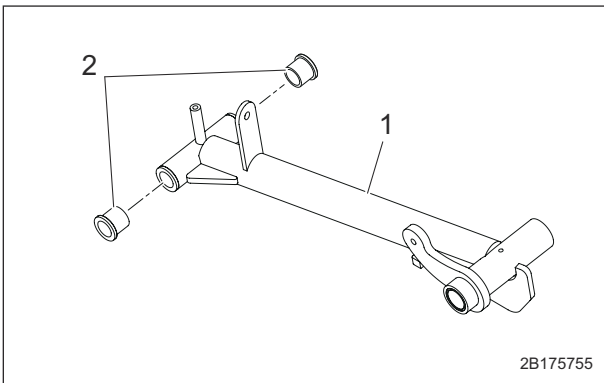

Replacement of Resin Bushing\_001

1	Lift arm
2	Resin bushing

■ LH66

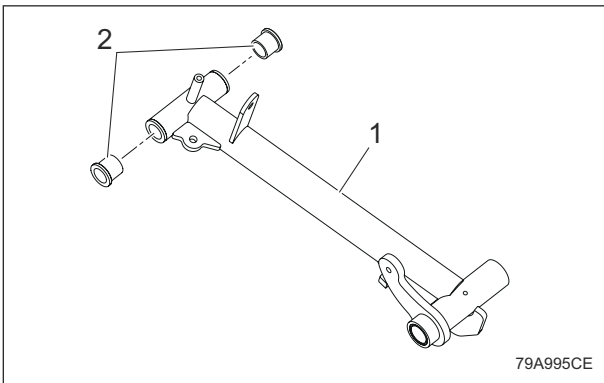

Replacement of Resin Bushing\_002

1	Lift arm
2	Resin bushing

### 2. Mower coupling (Mower unit #2, #3)

■ LS66

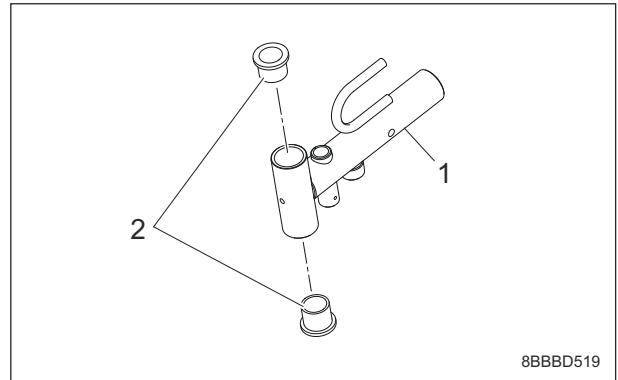

Replacement of Resin Bushing\_003

1	Mower coupling
2	Resin bushing

■ LH66

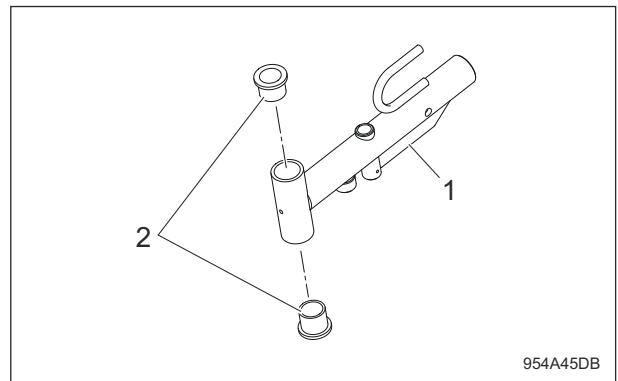

Replacement of Resin Bushing\_004

1	Mower coupling
2	Resin bushing

### 3. Mower arm (Mower unit #1, #2, #3)

Note:

The illustration shows the mower arm for mower unit #2.

■ LH66

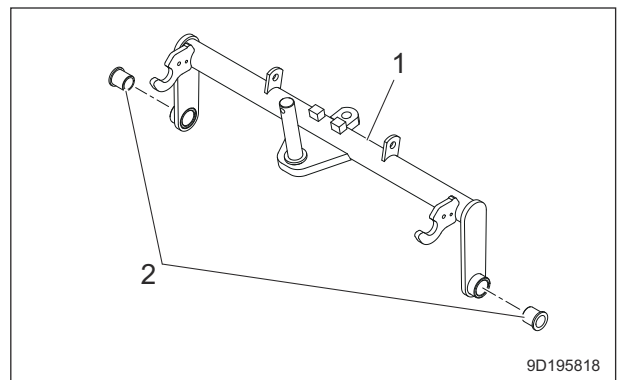

Replacement of Resin Bushing\_005

1	Mower arm
2	Resin bushing

## Replacement of Tires

## ■ Replacement of Front Tires

## 1. Removing front tires

Follow the steps below to remove the front tires:

## [1] Loosen the bolts.

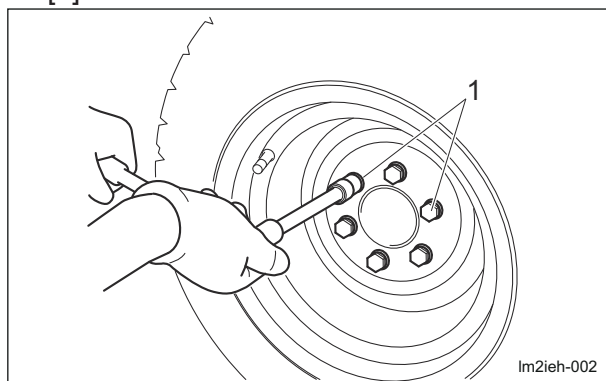

Replacement of Front Tires\_001

1	Heat-treated bolt
---	-------------------

[2] Securely place the jack beneath the jack-up point of the front left/right frame area, and then raise it until the tire lifts off the ground.

"Jack-up Points" (Page 6-2)

[3] Remove the bolts.

[4] Remove the tire from the wheel mounting seat.

## 2. Installing front tires

**Important**

Tighten the bolts in the tightening order (diagonally).

**Important**

Tighten the wheel mounting bolts on the specified torque by using a torque wrench.

For installing the front tires, reverse the removing procedure.

## ■ Replacement of Rear Tires

## 1. Removing rear tires

Follow the steps below to remove the rear tires

## [1] Loosen the bolts.

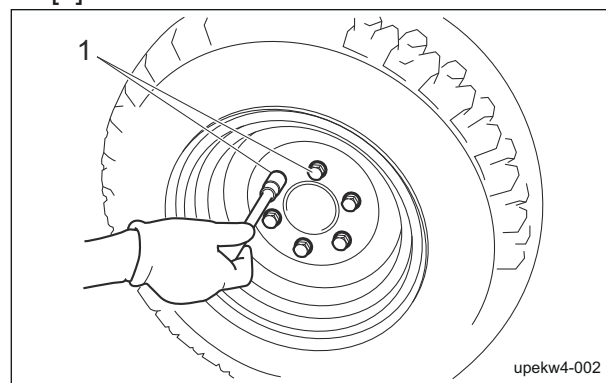

Replacement of Rear Tires\_001

1	Heat-treated bolt
---	-------------------

[2] Securely place the jack beneath the jack-up point of the rear frame area, and then raise it until the tire lifts off the ground.

"Jack-up Points" (Page 6-2)

[3] Remove the bolts.

[4] Remove the tire from the wheel mounting base.

## 2. Installing rear tires

**Important**

Tighten the bolts in the tightening order (diagonally).

**Important**

Tighten the wheel mounting bolts on the specified torque by using a torque wrench.

For installing the rear tires, reverse the removing procedure.

## Storage

### Long-Term Storage

Follow the instructions below for long-term storage of the machine.

#### 1. Cleaning

- Remove dirt, grass clippings, oil stains etc. completely from the main vehicle and engine.

#### 2. Replacing oil

- Inspect and replace the engine oil, hydraulic oil and element.

#### 3. Greasing and lubricating

- Supply oil and apply grease to appropriate parts.

#### 4. Battery

- Loosen the battery cutoff switch to disconnect the negative battery cable. Switch the ignition key to the "ON" position and check that the charge lamp and oil pressure lamp do not turn on.

#### 5. Fuel

- Remove the fuel from the fuel tank.

#### 6. Tire pneumatic pressure

- Set the tire air pressure slightly higher than normal, and then place the machine on a board to avoid humidity.

#### 7. Mower units

- When storing this machine, lower all the mower units unless a positive mechanical lock is provided.

#### 8. Storage location

- Cover the machine and store it in a dry place where it will not be exposed to rain.

**Precautions for Repair ..... Page 7-2**

**Adjustment and Replacement ..... Page 7-2**

Adjustment of Brake ..... Page 7-2

Adjustment of Parking Brake ..... Page 7-3

Adjustment of The Neutral Position  
of The Piston Pump ..... Page 7-4

Replacement of Fuse ..... Page 7-5

**Towing .....Page 7-6**

Towing the Machine in an  
Emergency .....Page 7-6

**Repair**

# Repair

## Precautions for Repair

### Warning

The chapter "Repair" in this manual describes practical measures which should be performed by a mechanic with expertise. The owner should instruct the mechanic with expertise to perform repair service for this machine.

### Caution

First, learn well the operations you plan to perform.

### Important

Use tools appropriate for each operation.

### Important

Use Baroness genuine parts for replacement and accessories. Our product warranty may be void if you use non-genuine parts for replacement or accessories.

## Adjustment and Replacement

### Adjustment of Brake

### Caution

If the brake wire becomes broken, the machine will be unable to stop. If there are cracks, damage or other defects, replace it immediately. Adjust the brake wire if the brakes become less effective.

### Important

Adjust the brake wire so that there is minimal play with the brake lever, and so that the brakes do not drag when the brake is released.

1. Adjust the foot brake by tightening the adjustment bolt on the brake wire.
  - Braking force will decrease if there is more play with the brake lever, and the brake pedal will feel lighter.

- Reducing play with the brake lever will increase braking force and make the brake pedal feel heavier.

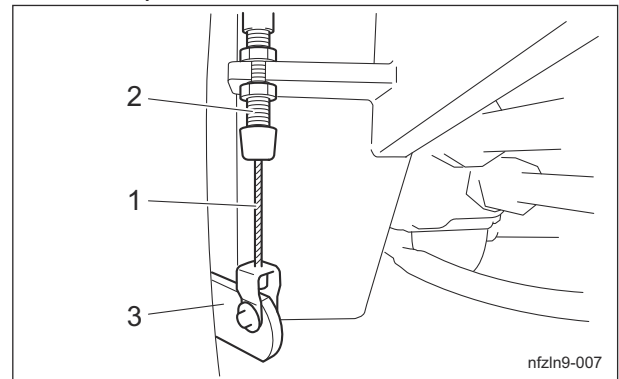

Adjustment of Brake\_001

1	Brake wire
2	Adjustment bolt
3	Brake lever

2. Start the engine and drive to check the following.
  - Make sure that heat is not generated in the brake area.
  - Make sure that the left and right brakes are equally effective.

### Caution

It may result in an unexpected accident if the left and right brakes are not equally effective.

3. If the left and right brakes are not equally effective, make fine adjustments with the adjustment bolt on the brake wire.

### Break-In of Brakes

If the brake shoes or brake pads are worn, replace them with new ones. Immediately after replacement, drive to break in the brakes if the effectiveness of the brakes is low. While driving, lightly operate the brakes to break in the contact areas.

## Adjustment of Parking Brake

### ⚠ Caution

Make sure that the brake wire is not cracked or damaged.

### Important

Make sure that the brake is effective on slopes and that it is not applied any longer when you release it. Adjust the parking brake system whenever there is any abnormality.

1. Stop the engine.
2. Follow the steps below to adjust the parking brake.

[1] Depress the brake pedal firmly, and then pull the parking brake lever to engage the latch on the notch.

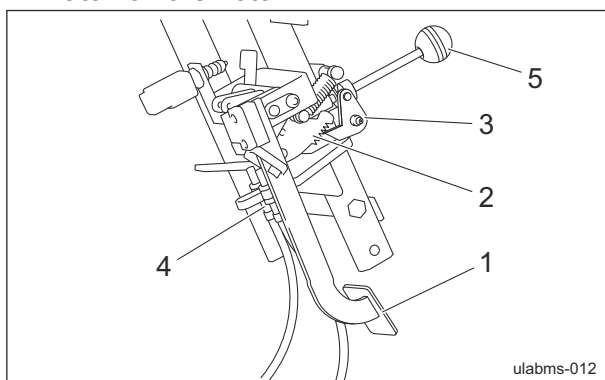

Adjustment of Parking Brake\_001

1	Brake pedal
2	Notch
3	Latch
4	Adjustment bolt
5	Parking brake lever

[2] Make adjustment with the adjustment bolt so as to locate position of the latch at 3 to 4 notches from the bottom.

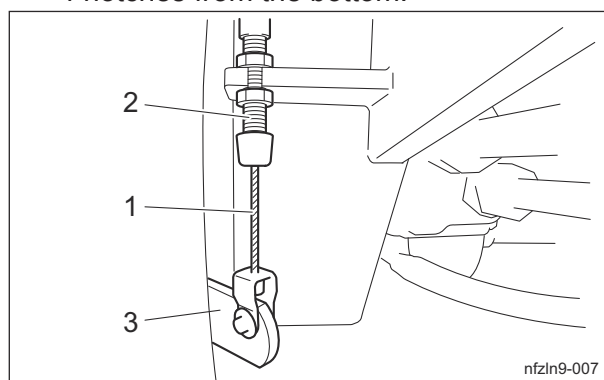

Adjustment of Parking Brake\_002

1	Brake wire
2	Adjustment bolt
3	Brake lever

# Repair

## Adjustment of The Neutral Position of The Piston Pump

### ⚠ Caution

Make sure not to touch rotating tires.

### ⚠ Caution

Be careful not to touch the muffler.

### ⚠ Caution

When adjusting the neutral position, pay close attention to abrupt start of the machine. Place the jacks beneath the jack-up points, and then lift the machine until all the tires get off the ground.

### Important

Make sure that there is no abnormality in the bearings of the trunnion lever. If there is an abnormality, perform a replacement before the following operation.

If the machine moves forward or backward while the traveling pedals are released, they are not set to the neutral position. Follow the steps below to make adjustments.

1. Stop the engine.
2. Place the jacks beneath the jack-up points, and then lift the machine off the ground. Use stable jack stands, and raise the machine until the tires lift off the ground. "Jack-up Points" (Page 6-2)
3. Make sure that no tires get contact with the jack stand.
4. Open the hood.
5. Make sure that the length of the spring of the lever adjuster is 53 mm (2.09 in). Loosen the lock nut as necessary to make adjustment.

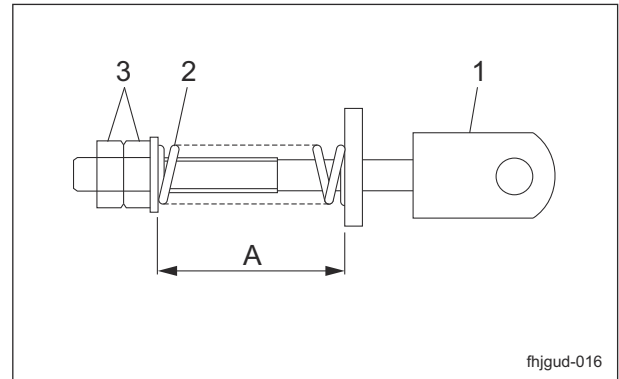

Adjustment of The Neutral Position of The Piston Pump\_001

1	Lever adjustment bracket
2	Spring
3	Lock nut
A	53 mm (2.09 in)

### 6. Adjust the neutral position.

Follow these steps to adjust the neutral position.

- When the tire moves in the direction of forward travel, slide the cam lever in direction A.
- When the tire moves in the direction of backward travel, slide the cam lever in direction B.

[1] Make sure that the engine has stopped.

[2] Turn the cam lever shaft bolt counterclockwise 60 ° or up to 120 ° to loosen it.

[3] Tap the cam lever fulcrum (pipe portion) with a plastic hammer in the direction of black arrow to slide the cam lever in the direction A or B.

[4] Tighten the cam lever shaft bolt.

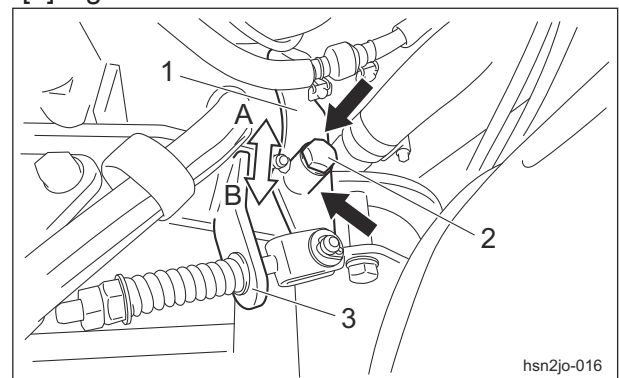

Adjustment of The Neutral Position of The Piston Pump\_002

1	Cam lever
2	Cam lever shaft bolt
3	Lever adjustment bracket

7. Start the engine, and rev it up to the maximum rpm.
8. Set the 2WD/3WD selector lever to the "2WD" position.
9. Check that the tires do not move.  
If a tire moves even slightly, stop the engine, and then repeat steps 6. to 9.

### Replacement of Fuse

**Important**

When performing maintenance on the electrical system, be sure to remove the negative battery wire.

**Important**

If a fuse blows, a short may have occurred within the electrical circuit. Check for the cause, such as faulty terminal connections, damaged wiring or terminals, or incorrect wiring.

**Important**

For fuse replacement, clean the fuse mounting area with use of compressed air before mounting the fuse.

### Fuse Box

The fuse box includes spare fuses and tools.

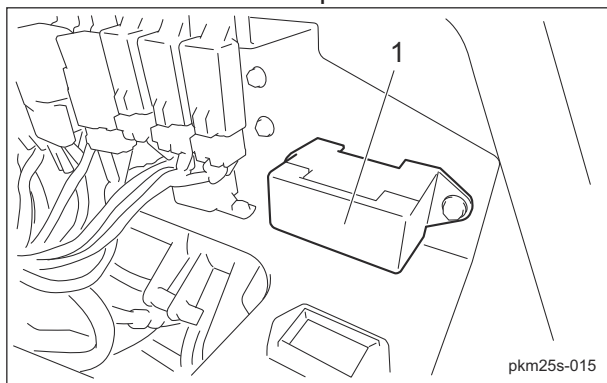

Fuse Box\_001

1	Fuse box
---	----------

The machine uses a mini fuse for automobiles.  
Replace an old fuse with a new fuse of the specified capacity.

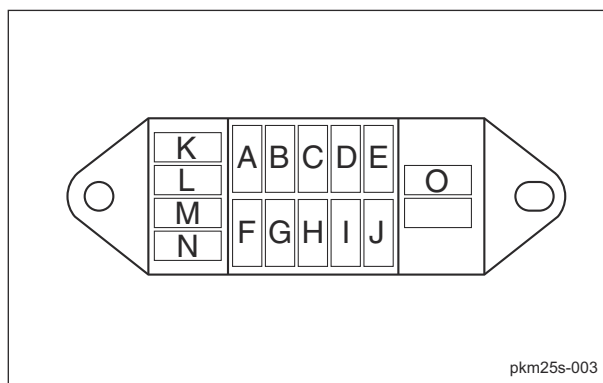

Fuse Box\_002

A	5 A	Glow lamp timer
B	5 A	Glow lamp
C	5 A	Charge lamp, oil pressure lamp (engine oil pressure lamp), water temperature gauge, buzzer, solenoid timer, hour meter, fuel gauge
D	15 A	Reel normal rotation solenoid, reel reverse rotation solenoid
E	15 A	(Unused)
F	10 A	Light, Diff-lock
G	5 A	Glow lamp timer (start signal)
H	5 A	Alternator
I	5 A	Interlock (reel control)
J	5 A	Interlock (mainly start safety)
K	5 A	Spare
L	5 A	
M	10 A	
N	15 A	
O		Tool

# Repair

## Fusible Link

Fuse capacities of the fusible links are 30 A and 50 A.

Engine stop solenoid: 30 A

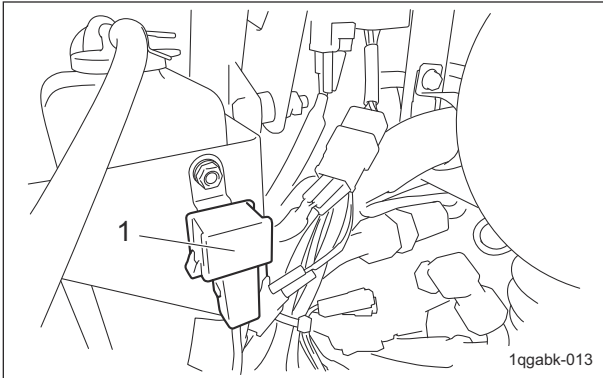

Fusible Link\_001

1	Fusible link (30 A)
---	---------------------

Battery: 50 A

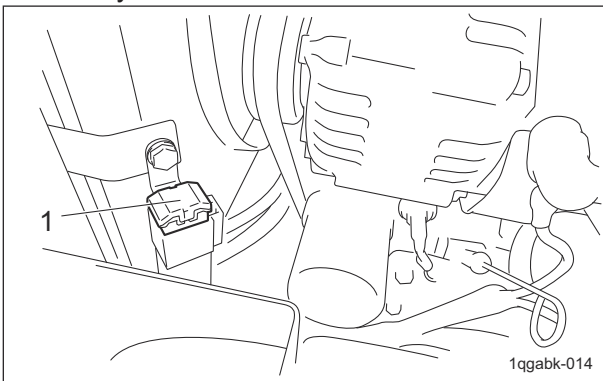

Fusible Link\_002

1	Fusible link (50 A)
---	---------------------

## Towing

### Towing the Machine in an Emergency

If the machine does not travel due to engine trouble, etc., you can move it in the following ways:

- Pushing by hand
- Towing (See the following procedure.)

#### ⚠ Caution

Before towing, check that the brake is applied effectively.

#### Important

Before starting the engine, be sure to close the bypass.

#### Important

Do not touch the unload valve except when towing the machine.

#### Important

When towing the machine, obey the following restrictions.

Obey the speed and the time restrictions to prevent damaging the pump or motor.

- Speed: Do not travel at a speed more than 3.0 km/h.
- Time: Do not tow the machine for more than 3 minutes.

When towing the machine for more than 3 minutes, start the engine and circulate the hydraulic oil in the hydraulic circuit.

Therefore, do not tow the machine until restart the engine after completed repairs.

1. Stop the engine.  
"Procedure to Stop Engine" (Page 5-13)
2. Apply the parking brake.
3. Chock the wheels.
4. Secure the machine with ropes.  
Front side

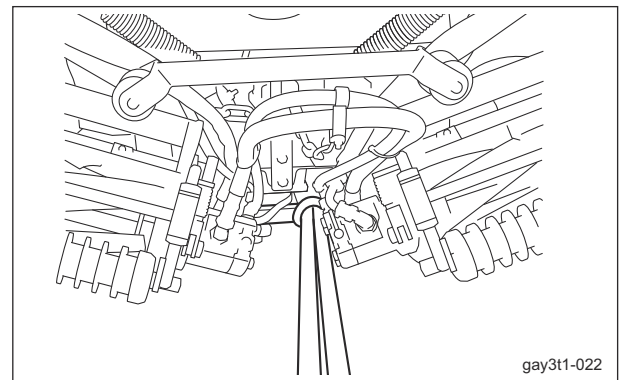

Towing the Machine in an Emergency\_001

**Important**

When using the tow hook on the rear wheel part to tow the machine, you cannot steer the machine.

The tow hook on the rear part of the machine should be used only when the tow hook on the front part cannot be used.

Rear side

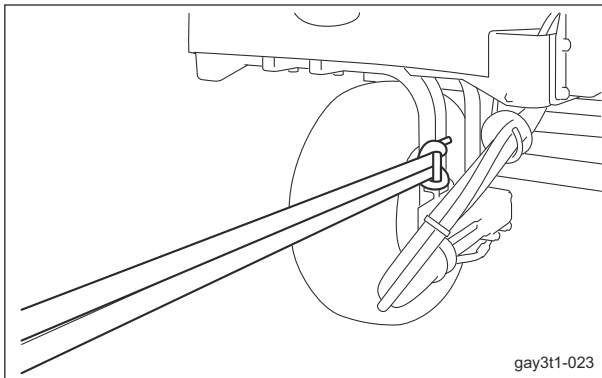

Towing the Machine in an Emergency\_002

5. Set the 2WD/3WD selector lever to the "2WD" position.

**Important**

For unloading, be sure to open the two unload valves.

Opening only one unload valve will cause the hydraulic system to malfunction.

6. Open the bypass.

The unload valves are located under the floor panel.

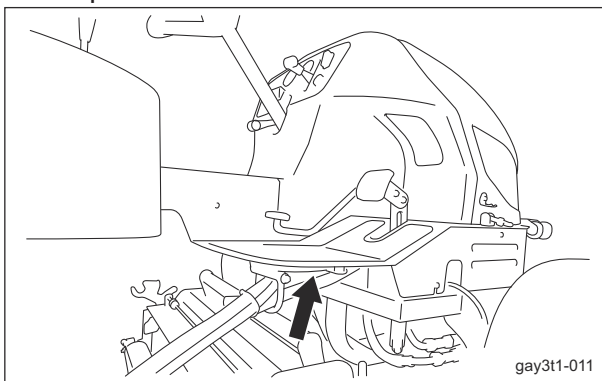

Towing the Machine in an Emergency\_003

- [1] Loosen the lock nut on each of the two unload valves.
- [2] Tighten the two bolts to push in the unload valve operating pins.

- [3] Tighten the lock nut on each of the two unload valves.

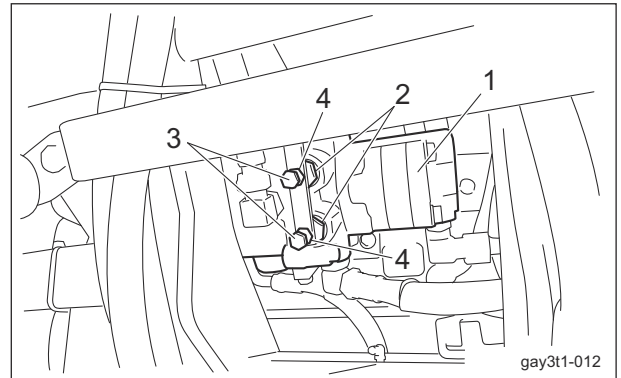

Towing the Machine in an Emergency\_004

1	Piston pump
2	Unload valve
3	Bolt
4	Lock nut

7. Remove the wheel stoppers.
8. Release the parking brake.

**Warning**

While towing, always keep your foot on the brake pedal and make sure you can depress the brake pedal at any time to stop.

9. Tow the machine slowly.
10. Close the bypass after towing.
  - [1] Loosen the lock nut on each of the two unload valves.
  - [2] Loosen the two bolts to return the unload valve operating pins to their original positions.
  - [3] Tighten the lock nut on each of the two unload valves.



# Appended Table

---

**Tightening Torques .....Page 8-2**  
    Standard Tightening Torques .....Page 8-2  
    Principal Tightening Torques ..... Page 8-5

**Daily Check List ..... Page 8-7**

**Maintenance Schedule ..... Page 8-8**

**List of Adjusted Values ..... Page 8-12**

Appended Table

# Appended Table

---

## Tightening Torques

### Important

Refer to the Tightening Torque table.  
Note that the Baroness product warranty may not apply to defects caused by incorrect or overtorque tightening, etc.

## Standard Tightening Torques

### Bolts and Nuts



### Important

A number of bolts are used in each part of this machine.  
Be sure to re-tighten the bolts and nuts, because they may be loosened at the earlier stage of the use.

- As to the bolts and nuts without any special instruction, tighten them in appropriate tightening torque with proper tool.  
Too much tightening may cause the looseness or damage of the screw.
- The strength of tightening is determined by types of screws, strength, the friction of thread face or base face and others.  
The table below is for the galvanized or parkerized bolts.  
In case that the strength of internal thread is weak, it is not applied.
- Do not use rusty or sand attached "screw."  
Otherwise, it may cause insufficient tightening even if you apply the specified tightening torque.  
The friction of the screw face becomes higher and the tightening torque is canceled out by the friction, therefore sufficient tightening cannot be applied.
- If "screw" is wet by water or oil, do not tighten it with normal tightening torque.  
If the screw is wet, the torque coefficient will get smaller and it may result in too much tightening.  
Too much tightening may cause looseness by the screw stretched or result in damage.
- Do not use a bolt experienced too much burden.
- Using the impact wrench requires the skill.  
Do exercise as much as possible for steady tightening.

# Appended Table

Nominal diameter	General bolt		
	Strength classification 4.8		
	 tib3yb-001		
	N-m	kgf-cm	lb-in
M5	3 - 5	30.59 - 50.99	26.55 - 44.26
M6	7 - 9	71.38 - 91.77	61.96 - 79.66
M8	14 - 19	142.76 - 193.74	123.91 - 168.17
M10	29 - 38	295.71 - 387.49	256.68 - 336.34
M12	52 - 67	530.24 - 683.20	460.25 - 593.02
M14	70 - 94	713.79 - 958.52	619.57 - 831.99
M16	88 - 112	897.34 - 1142.06	778.89 - 991.31
M18	116 - 144	1,182.85 - 1,468.37	1,026.72 - 1,274.54
M20	147 - 183	1,498.96 - 1,866.05	1,301.10 - 1,619.73
M22	295	3,008.12	2,611.05
M24	370	3,772.89	3,274.87
M27	550	5,608.35	4,868.05
M30	740	7,545.78	6,549.74

Nominal diameter	Heat-treated bolt					
	Strength classification 8.8			Strength classification 10.9		
	 tib3yb-002			 tib3yb-003		
	N-m	kgf-cm	lb-in	N-m	kgf-cm	lb-in
M5	5 - 7	50.99 - 71.38	44.26 - 61.96	7 - 10	71.38 - 101.97	61.96 - 88.51
M6	8 - 11	81.58 - 112.17	70.81 - 97.36	14 - 18	142.76 - 183.55	123.91 - 159.32
M8	23 - 29	234.53 - 295.71	203.57 - 256.68	28 - 38	285.52 - 387.49	247.83 - 336.34
M10	45 - 57	458.87 - 581.23	398.30 - 504.51	58 - 76	591.43 - 774.97	513.36 - 672.68
M12	67 - 85	683.20 - 866.75	593.02 - 752.34	104 - 134	1,060.49 - 1,366.40	920.50 - 1186.03
M14	106 - 134	1,080.88 - 1,366.40	938.21 - 1,186.03	140 - 188	1,427.58 - 1,917.04	1,239.14 - 1,663.99
M16	152 - 188	1,549.94 - 1,917.04	1,345.35 - 1,663.99	210 - 260	2,141.37 - 2,651.22	1,858.71 - 2,301.26
M18	200 - 240	2,039.40 - 2,447.28	1,770.20 - 2,124.24	280 - 340	2,855.16 - 3,466.98	2,478.28 - 3,009.34
M20	245 - 295	2,498.27 - 3,008.12	2,168.50 - 2,611.05	370 - 450	3,772.89 - 4,588.65	3,274.87 - 3,982.95
M22	-	-	-	530	5,404.41	4,691.03
M24	-	-	-	670	6,831.99	5,930.17
M27	-	-	-	1,000	10,197.00	8,851.00
M30	-	-	-	1,340	13,663.98	11,860.34

**Note:**  
The same values are applied to "fine screw thread."

## Appended Table

### Hydraulic Hose

The tightening torques for union joints and union adaptors with parallel pipe threads (G, PF) are shown in the table below.

A union joint or adaptor will not become loose or leak as long as it is tightened by the specified torque.

If fluid leaks from the sealed portion, do not attempt to tighten the union joint or adaptor forcibly.

Examine whether any foreign matter or scratches are present on the seat surface.

Tightening a union joint or adaptor forcibly could damage the connection of the joints.

When tightening a union joint or adaptor, use a torque wrench where possible and firmly tighten it by an appropriate torque.

Nominal diameter of the hose size	Nominal diameter of the parallel pipe threads (G, PF)	Tightening torque		
		N-m	kgf-cm	lb-in
6	1/4	25	254.93	221.28
9	3/8	50	509.85	442.55
12	1/2	60	611.82	531.06
15	3/4	120	1,223.64	1,062.12
19	3/4	120	1,223.64	1,062.12
25	1	140	1,427.58	1,239.14
32	1-1/4	170	1,733.49	1,504.67
38	1-1/2	210	2,141.37	1,858.71
50	2	250	2,549.25	2,212.75

### Fittings with Parallel Threads (O-Ring Seal Type)

The tightening torques for fittings with parallel threads (O-ring seal method) are shown in the table below.

Tightening the fitting forcibly with a spanner or other such tool to secure it to a set position could damage the fitting, its washers, and other parts.

When tightening an adjustable elbow, use a torque wrench where possible and firmly tighten it by an appropriate torque.

Nominal diameter of thread	Tightening torque		
	N-m	kgf-cm	lb-in.
1/4	34.32 - 49.03	349.96 – 499.96	303.77 – 433.96
3/8	68.65 - 78.45	700.02 – 799.95	607.62 – 694.36
1/2	98.07 - 117.68	1,000.02 – 1,199.98	868.02 – 1,041.59
3/4	147.10 - 176.52	1,499.98 – 1,799.97	1,301.98 – 1,562.38
1	245.17 - 274.59	2,500.00 – 2,799.99	2,170.00 – 2,430.40
1-1/4	294.20	2,999.96	2,603.96
1-1/2	294.20	2,999.96	2,603.96
2	392.27	3,999.98	3,471.98

# Appended Table

## Principal Tightening Torques

### Tightening Torque by Model

LM331

Tighten the following bolts and nuts at the torque specified in the table.

For thread locking adhesive, apply a middle strength thread locker (ThreeBond 1322 or equivalent anaerobic sealant).

Location		Code	Part name	Tightening torque			Thread locking adhesive
				N-m	kgf-cm	lb-in	
Front wheel	Wheel mounting base	K0160000492	NUT, SPECIAL P1.5 M24	180 - 200	1,835.46 - 2,039.40	1,593.18 - 1,770.20	○
	Wheel	K0011120302	BOLT, HT P1.5 M12-30	67 - 85	683.20 - 866.75	593.02 - 752.34	-
Brake pedal		K0010080252	BOLT, HT M8-25	23 - 38	234.53 - 387.49	203.57 - 336.34	-
Rear wheel	Wheel mounting base	K0138240002	NUT, HIGH SLOTTED P1.5 M24	180 - 200	1,835.46 - 2,039.40	1,593.18 - 1,770.20	-
	Wheel	K0011120302	BOLT, HT P1.5 M12-30	67 - 85	683.20 - 866.75	593.02 - 752.34	-
Steering shaft housing	(#10001 - 19999)	K0010100402	BOLT, HT M10-40	45 - 76	458.87 - 774.97	398.30 - 672.68	-
	(#20001 - 20044)	K0010100502	BOLT, HT M10-50	45 - 76	458.87 - 774.97	398.30 - 672.68	-
	(#20045-)	K0010100402	BOLT, HT M10-40	45 - 76	458.87 - 774.97	398.30 - 672.68	-
Steering shaft lid		K0010100252	BOLT, HT M10-25	45 - 76	458.87 - 774.97	398.30 - 672.68	-
Engine base		K0017100252	BOLT, SMALL HT P1.25 M10-25	45 - 57	458.87 - 581.23	398.30 - 504.51	-
Pump bracket		K0010080302	BOLT, HT M8-30	23 - 38	234.53 - 387.49	203.57 - 336.34	-
Engine pulley		K0010080202	BOLT, HT M8-20	23 - 38	234.53 - 387.49	203.57 - 336.34	-
Hydraulic pump		K0010120502	BOLT, HT M12-50	67 - 134	683.20 - 1,366.40	593.02 - 1,186.03	-
Steering cylinder		LM331--0722Z2	BOLT, STEPPED M12	-	-	-	○
		K0000080202	BOLT, M8-20	-	-	-	○
Electric components for engine		-	Starter B terminal (M8)	9.8 - 11.8	99.93 - 120.32	86.74 - 104.44	-
		-	Alternator B terminal (M6)	5.9 - 9.8	60.16 - 99.93	52.22 - 86.74	-
		-	Glow plug connection terminal nut (M4)	1.0 - 1.8	10.20 - 18.35	8.85 - 15.93	-
Proximity switch NO V-out		K0100050002	NUT, M5	2.5	25.49	22.13	-
		K0000050202	BOLT, M5-20	2.5	25.49	22.13	-
ROPS		K0010120402	BOLT, HT M12-40	104 - 134	1,060.49 - 1,366.40	920.50 - 1,186.03	-

# Appended Table

---

Location	Code	Part name	Tightening torque			Thread locking adhesive
			N-m	kgf-cm	lb-in	
Battery terminal	K3610000950	WIRE, BATTERY (+) 2500	6	61.18	53.11	-
	K3612000110	SWITCH, CUT OFF BATTERY	14	142.76	123.91	-

## Daily Check List

- . . . Inspect, adjust, supply, clean (first time)
- . . . Inspect, adjust, supply, clean
- ▲ . . . Replace (first time)
- △ . . . Replace

Maintenance Item		Before Work	After Work	Remarks
Engine	*1	Check engine oil	○	
	*1	Check fuel	○	
		Check fuel filter	○	
	*1	Check coolant	○	
	*1	Check air cleaner	○	
		Check dust screen	○	
		Check radiator	○	
		Check engine area	○	
		Clean dust screen		○
		*1	Clean radiator	
		Clean engine area		○
Main vehicle		Check hydraulic oil	○	
		Check tire	○	
	*2	Check battery	○	
		Check oil cooler	○	
		Check cover	○	
		Check wire	○	
		Check brake pedal	○	
		Check parking brake lever	○	
		Check traveling pedal	○	
		Check oil or water leaks	○	
		Check ball proof net	○	
		Check machine exterior	○	
		Check bolts and nuts	○	
		Check hour meter	○	
		Check water temperature gauge	○	
		Check fuel gauge	○	
		Check pilot lamp	○	
		Check safety mechanisms	○	
		Check steering wheel	○	
		Check lighting	○	
	Check grass catcher	○		
	Clean oil cooler		○	
	Clean machine exterior		○	

- \*1: Refer to the Engine's Owner's Manual.
- \*2: Refer to the Battery's Owner's Manual.

# Appended Table

## Maintenance Schedule

LM331

● . . . Inspect, adjust, supply, clean (first time)

○ . . . Inspect, adjust, supply, clean

▲ . . . Replace (first time)

△ . . . Replace

Maintenance Item		Before Work	After Work	Every Week	Every 50 hrs.	Every 100 hrs.	Every 200 hrs.	Every 250 hrs.	Every 400 hrs.	Every 500 hrs.	Every 800 hrs.	Every 1500 hrs.	Every 3000 hrs.	Every month	Every 6 months	Every year	Every 2 years	Every 4 years	When Required	Remarks	
Engine	*3		○	○																Open valve every week or daily in dusty conditions	
	*2.*3				○																
						○															
						○															
						○															
	*2.*3					○															Air cleaner should be cleaned more often in dusty conditions than in normal conditions
	*3					○															
	*2.*3						○														
*3						○								○						Check every 200 hours or every 6 month whichever comes earlier	

# Appended Table

Maintenance Item		Before Work	After Work	Every Week	Every 50 hrs.	Every 100 hrs.	Every 200 hrs.	Every 250 hrs.	Every 400 hrs.	Every 500 hrs.	Every 800 hrs.	Every 1500 hrs.	Every 3000 hrs.	Every month	Every 6 months	Every year	Every 2 years	Every 4 years	When Required	Remarks	
Engine		Clean of water separator							○												
	*1.*3	Clean fuel tank interior								○											
	*1.*3	Clean water jacket (radiator interior)								○											
	*1.*3	Check valve clearance									○										
	*1.*2.*3	Check of fuel injection nozzle injection pressure										○									
	*1.*2.*3	Check of injection pump											○								
	*3	Replace engine oil			▲	△											△				Initial 50 hours, thereafter every 200 hours or every year whichever comes earlier
	*3	Replace engine oil filter cartridge			▲	△											△				Initial 50 hours, thereafter every 200 hours or every year whichever comes earlier
		Replace fuel filter cartridge								△											
	*3	Replace fan belt									△							△			Replace every 500 hours or 2 years whichever comes earlier

Appended Table

# Appended Table

Maintenance Item		Before Work	After Work	Every Week	Every 50 hrs.	Every 100 hrs.	Every 200 hrs.	Every 250 hrs.	Every 400 hrs.	Every 500 hrs.	Every 800 hrs.	Every 1500 hrs.	Every 3000 hrs.	Every month	Every 6 months	Every year	Every 2 years	Every 4 years	When Required	Remarks
Engine	*2.*3															△				Replace every 6 cleanings or every year whichever comes earlier
	*3																△			
	*3																△			
	*1.*2.*3																△			
	*1.*2.*3																△			
Main vehicle	Check hydraulic hose (Moving part)	○																		
	Check belt	○																		
	Grease and lubricate				○	○										○				
	Check electrical wiring				●	○														
	Check wheel mounting bolts				●	○														
	Check hydraulic hose (Fixed part) condition					○								○						

# Appended Table

Maintenance Item		Before Work	After Work	Every Week	Every 50 hrs.	Every 100 hrs.	Every 200 hrs.	Every 250 hrs.	Every 400 hrs.	Every 500 hrs.	Every 800 hrs.	Every 1500 hrs.	Every 3000 hrs.	Every month	Every 6 months	Every year	Every 2 years	Every 4 years	When Required	Remarks		
Main vehicle								○														
																			○			
					▲					△												
					▲					△												
					▲					△												
	*4																	△				
	*1																	△				
	*1.*5																	△				
	*1																		△			
																		△				
	*1																			△		
	*1																			△		
																				△		
	*1																			△		

Appended Table

- \*1: Consult your local Baroness Dealer or local KUBOTA Dealer for this service.
- The items above (\*2 marked) are registered as emission related critical parts by KUBOTA in the U.S. EPA nonroad emission regulation. As the engine owner, you are responsible for the performance of the required maintenance on the engine according to the above instruction. Please see the Engine's Warranty Statement in detail.

## Appended Table

---

- \*3: Refer to the Engine's Owner's Manual.
- \*4: Refer to the Battery's Owner's Manual.
- \*5: Be sure to replace hydraulic hoses for steering cylinder and hydraulic hoses for hydraulic motor of wheel relating to steering every two years.
- The values for consumables are not guaranteed.

### List of Adjusted Values

Fan belt		10 mm (0.39 in)	Slack when applying 98 N (10 kgf) force to the belt at the middle point
		Adjustment: 200 - 300 N (20.39 - 30.59 kgf) Replacement: 267 - 361 N (27.23 - 36.81 kgf)	Measurement of belt tension by using a sonic type tension meter
Mower stabilizer spring	#2, #3	140 mm (5.51 in)	Total length of spring
	#1	60 mm (2.36 in)	Total length of spring
Hydraulic pump drive belt		30 - 35 mm (1.18 - 1.38 in)	Total length of spring
Piston pump		53 mm (2.09 in)	Total length of spring (lever adjuster)

**Daily Check Records ..... Page 9-2**

**Maintenance Records .....Page 9-5**

Records

# Records

## Daily Check Records

LM331

Use this table freely for your records of the daily check.

Model		Serial Number	
-------	--	---------------	--

Items											
Engine	Check engine oil										
	Check fuel										
	Check fuel filter										
	Check coolant										
	Check air cleaner										
	Check dust screen										
	Check radiator										
	Check engine area										
	Clean dust screen										
	Clean radiator										
	Clean engine area										

Items											
Main vehicle	Check hydraulic oil										
	Check tire										
	Check battery										
	Check oil cooler										
	Check cover										
	Check wire										
	Check brake pedal										
	Check parking brake lever										
	Check traveling pedal										
	Check oil or water leaks										
	Check ball proof net										
	Check machine exterior										
	Check bolts and nuts										
	Check hour meter										

Records

# Records

Items											
Main vehicle	Check water temperature gauge										
	Check fuel gauge										
	Check pilot lamp										
	Check safety mechanisms										
	Check steering wheel										
	Check lighting										
	Check grass catcher										
	Clean oil cooler										
	Clean machine exterior										

**Maintenance Records**

LM331  
Use this table freely for your records of the maintenance.

Model		Serial Number	
Items			
Engine	Open air cleaner evacuator valve to remove dust		
	Check fuel hoses and clamp bands		
	Clean fuel filter		
	Check water separator		
	Draining of water separator		
	Clean air cleaner element		
	Check of fan belt tightness		
	Check intake air line (air cleaner hose)		
	Check radiator hoses and clamp bands		
	Clean of water separator		
	Clean fuel tank interior		
	Clean water jacket (radiator interior)		

Records

# Records

Items											
Engine	Check valve clearance										
	Check of fuel injection nozzle injection pressure										
	Check of injection pump										
	Replace engine oil										
	Replace engine oil filter cartridge										
	Replace fuel filter cartridge										
	Replace fan belt										
	Replace air cleaner element										
	Replace radiator coolant (L.L.C.)										
	Replace radiator hoses and clamp bands										
	Replace fuel hoses and clamp bands										
	Replace intake air line (air cleaner hose) and clamp bands										
Main vehicle	Check hydraulic hose (Moving part)										
	Check belt										

Items											
Main vehicle	Grease and lubricate										
	Check electrical wiring										
	Check wheel mounting bolts										
	Check hydraulic hose (Fixed part) condition										
	Grease hydraulic motor shaft of the mower unit										
	Adjust lift arm spring										
	Replace hydraulic oil										
	Replace hydraulic oil line filter										
	Replace air breather element										
	Replace battery										
	Replace hydraulic hoses (Moving part)										
	Replace hydraulic hoses (Moving part) relating to steering										
	Replace hydraulic hoses (Fixed part)										
Replace resin bushing											

Records

# Records

---

Items											
Main vehicle	Replace brake cables										
	Replace traveling cable										
	Replace throttle wire										
	Replace brake pads										

**BARONESS**<sup>®</sup>  
Quality on Demand

 **KYOEISHA CO., LTD.**  
Head Office 1-26, Miyuki-cho, Toyokawa-city, Tel :+81-533-84-1390  
Aichi-pref, 442-8530 JAPAN Fax:+81-533-84-1220