

LM351

3-Unit Reel Mower

Owner's Operating Manual

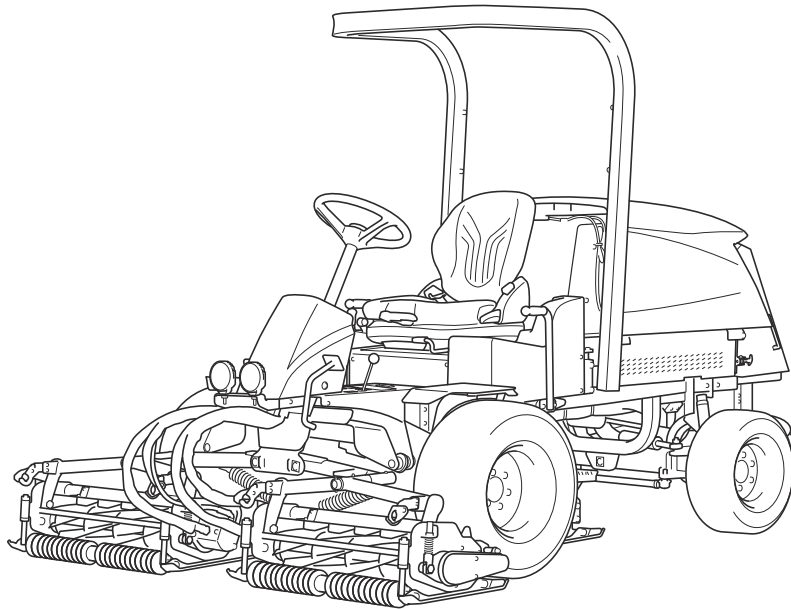

Serial No. LM351: 10001-

"Required reading"
Read this manual before using the machine.

BARONESS[®]
Quality on Demand

Original Instructions Ver.1.5

LM351

Regulations

EU Regulations

(For EU)

This product complies with all relevant EU Regulations.

For more information, please refer to the Declaration of Conformity attached.

Thank you for purchasing the Baroness product. This manual describes the proper handling, adjustment, and inspection of your product. We hope you will use the product safely, and take advantage of its best performance.

Keeping the Owner's Operating Manual

Keep this Manual in the box on the left side of the fuel tank.

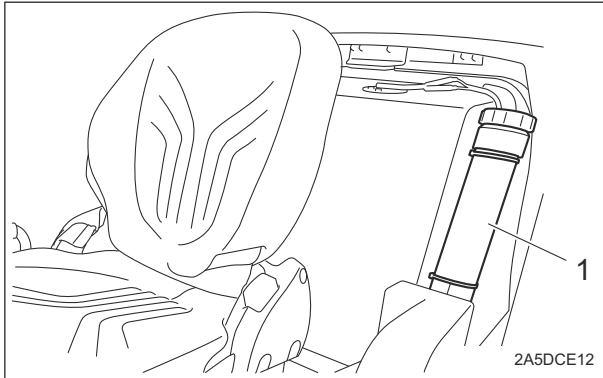

Keeping the Owner's Operating Manual_001

1	Box
---	-----

QR Code

(*QR Code is a registered trademark of DENSO WAVE INCORPORATED.)

A QR code label is affixed on the machine.

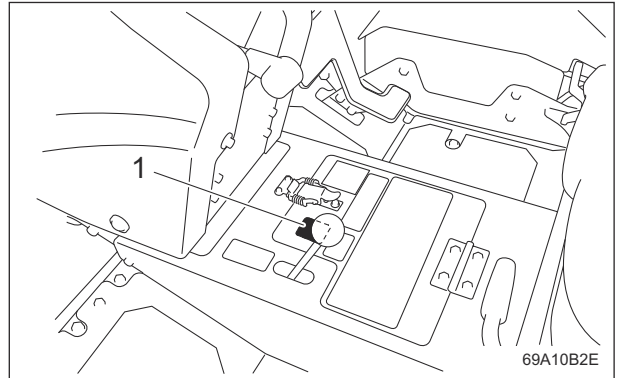

QR Code_001

1	QR code label
---	---------------

Scan the QR code with your smartphone for easy access to Baroness Manual Reference Service where you can browse Owner's Operating Manual and Parts Catalog.
<https://doc.baroness-international.com/manuals/LM351>



QR Code_002

Introduction

Read this manual carefully to ensure that you thoroughly understand how to properly operate and maintain the product, and to avoid causing injury to yourself or others.

The operator is responsible for operating the product properly and safely.

Maintenance service for this machine should be performed by a mechanic with expertise.

If you have any questions concerning maintenance or genuine parts, please contact a Baroness dealer or Kyoisha.





When making inquiries about your product, please specify the model and serial number.

When loaning or transferring the product, please also provide this manual together with the product.

Kyoeisha Co., Ltd.

Warning Symbols

This manual uses the following warning symbols for handling precautions that are important for your safety.

 <small>696cq5-001</small>	Warning symbol
<p>This symbol indicates the articles regarding “Danger,” “Warning,” or “Caution.” Those articles describe important safety precautions and so read them carefully to understand completely before operating the machine.</p> <p>Failure to adequately follow these safety precautions may cause an accident.</p>	
<p> Danger</p> <p>This symbol indicates that serious injury or death will occur if the warning is ignored.</p>	
<p> Warning</p> <p>This symbol indicates that serious injury or death may occur if the warning is ignored.</p>	
<p> Caution</p> <p>This symbol indicates that injury or damage to property may occur if the warning is ignored.</p>	
<p>Important</p> <p>This symbol indicates precautions on the mechanism of the machine.</p>	

Precautionary Statement

 Caution

The information described in this manual is subject to change for improvement without prior notice.

When replacing parts, be sure to use genuine Baroness parts or parts designated by Kyoisha.

Note that the Baroness product warranty may not apply to defects caused by the use of parts from other companies.

Prior to use, carefully read the following manuals to thoroughly understand the contents for safe and correct operation.

- Baroness Owner's Operating Manual
- The Engine's Owner's Manual
- The Battery's Owner's Manual

Purpose

This product is intended for cutting turf grass at golf courses.

Do not use this product in any way other than its intended purpose, and do not modify this product.

Operating this product for other purposes and modifying it may be very dangerous and may cause damage to the product.

In addition, this product is not authorized for operation as a special motor vehicle. Do not operate it on public roads.

LM351

Introduction

Safety	Page 1-1	Maintenance	Page 6-1
Safe Operating Practices	Page 1-2	Precautions for Maintenance	Page 6-2
Disposal	Page 2-1	Jacking Up The Machine	Page 6-2
Recycle and Waste Disposal	Page 2-2	Inspection and Cleaning	Page 6-3
Product Overview	Page 3-1	Supplying Fluids	Page 6-8
Specifications	Page 3-2	Greasing	Page 6-12
Names of Each Section	Page 3-4	Lubrication	Page 6-15
Regulation Decals	Page 3-7	Adjustment	Page 6-16
Safety Signs and Instruction Signs	Page 3-11	Replacement	Page 6-19
Operation Decals	Page 3-16	Storage	Page 6-28
Description of Functions	Page 4-1	Repair	Page 7-1
Light Switch	Page 4-2	Precautions for Repair	Page 7-2
Throttle Lever	Page 4-2	Adjustment	Page 7-2
Mower Unit Up/Down Lever	Page 4-2	Replacement	Page 7-5
Reel Rotation Switch	Page 4-3	Towing	Page 7-6
Stop Valve	Page 4-3	Appended Table	Page 8-1
Reel Forward/Reverse Switch	Page 4-4	Tightening Torques	Page 8-2
Key Switch	Page 4-4	Daily Check List	Page 8-7
USB Socket	Page 4-4	Maintenance Schedule	Page 8-8
Tilt Lever	Page 4-5	List of Adjusted Values	Page 8-13
Traveling Pedal	Page 4-5	Records	Page 9-1
Pedal Stopper	Page 4-5	Daily Check Records	Page 9-2
Brake Pedal	Page 4-6	Maintenance Records	Page 9-5
Parking Brake Lever	Page 4-6		
Reel Rotation/Stop Switching Lever	Page 4-6		
Instruments on the Operation Panel	Page 4-7		
Safety Device	Page 4-9		
Warning Mechanisms	Page 4-9		
Handling Instructions	Page 5-1		
Operations before Service	Page 5-2		
Inspection before Use	Page 5-4		
Adjustment before Work	Page 5-10		
Mounting and Dismounting	Page 5-11		
Start/Stop of Engine	Page 5-11		
Parking and Stopping	Page 5-13		
Move	Page 5-13		
Cutting Work	Page 5-14		
Transporting	Page 5-15		
Cleaning after Use	Page 5-16		
Storage	Page 5-17		

LM351

Contents

Safe Operating Practices Page 1-2

Training Page 1-2

Preparation Page 1-2

Operation Page 1-3

Maintenance Page 1-4

Storage Page 1-5

Safety

Failure to adequately follow these safety precautions may cause an accident resulting in injury or death.

Danger

This product is designed to ensure safe operation and has been tested and inspected thoroughly before shipment from the factory. The product is equipped with safety devices to prevent accidents.

However, whether the product demonstrates its original performance level depends on the manner in which it is operated and handled, as well as the manner in which it is managed on a daily basis.

Inappropriate use or management of the product may result in injury or death.

Observe the following safety instructions to ensure safe operation.

Safe Operating Practices

Training

1. Read this manual and other training material carefully.

Be familiar with the controls, safety signs, and the proper use of the equipment.

2. If the operator or mechanic can not read the language used in this manual, it is the owner's responsibility to explain this material to them.

3. All operators and mechanics should seek and obtain professional and practical instruction.

The owner is responsible for training the users.

Such instruction should emphasize:

- [1] The need for care and concentration when working with ride-on machines.

- [2] Control of a ride-on machine sliding on a slope will not be regained by the application of the brake.

The main reasons for loss of control are

- Insufficient wheel grip
- Being driven too fast
- Inadequate braking
- The type of machine is unsuitable for its task
- Lack of awareness of the effect of ground conditions, especially slopes
- Incorrect hitching and load distribution

4. Never allow children or people unfamiliar with these instructions to use or service the machine.

Local regulations may restrict the age of the operator.

5. The owner/user can prevent and is responsible for accidents or injuries occurring to themselves, other people, or property.
6. Keep in mind that the owner, operator, and mechanic are responsible for accidents or hazards occurring to other people or their property.
7. The ROPS is an integral and effective safety device.
Do not remove or alter the ROPS.
8. Replace a damaged ROPS.
Do not repair or alter.
9. You can find additional safety information where needed throughout this manual.
10. Determine the left and right sides of the machine from the normal operating position.

Preparation

1. Evaluate the terrain to determine what accessories and attachments are needed to properly and safely perform the job.
Only use accessories and attachments approved by the manufacturer.
2. While operating, always wear substantial footwear, long trousers, hard hat, safety glasses, mask, and ear protection.
Long hair, loose clothing, or jewelry may get tangled in moving parts.
Do not operate the equipment when barefoot or wearing open sandals.
3. Inspect the area where the equipment is to be used and remove all objects such as rocks, toys and wire which can be thrown by the machine.
4. Keep children out of the operating area and under the watchful care of a responsible adult other than the operator.
5. Exercise care in the handling of fuel.

Warning

Fuel is highly flammable.

Take the following precautions:

- [1] Store fuel in containers specifically designed for this purpose.

- [2] Add fuel before starting the engine.
Never remove the cap of the fuel tank or add fuel while the engine is running or when the engine is hot.
- [3] Refuel outdoors only and do not smoke while refueling.
- [4] If fuel is spilled, do not attempt to start the engine but move the machine away from the area of spillage and avoid creating any source of ignition until petrol vapours have dissipated;
- [5] Replace all fuel tanks and container caps securely.
6. Check that operator's presence controls, safety switches and shields are attached and functioning properly.
Do not operate unless they are functioning properly.
7. If the brake operation is faulty, be sure to adjust or repair them before operating the machine.
8. If the handlebar has noticeable play, be sure to adjust or repair them before operating the machine.
9. Replace faulty mufflers.
10. On multi-cylinder/multi-reel machines, take care as rotating one cylinder/reel can cause other cylinders/reels to rotate.
5. Never operate the machine with damaged guards, shields, or without safety protective devices in place.
Be sure all interlocks are attached, adjusted properly, and functioning properly.
6. Keep hands and feet away from the rotating parts.
7. Do not carry passengers.
8. Never operate while people, especially children, or pets are nearby.
9. Only operate in good light, keeping away from holes and hidden hazards.
10. Do not operate the machine when there is the risk of lightning.
11. Do not operate the machine in rain or wet conditions.
This may increase the risk of electric shock.
12. Do not stop or start suddenly.
13. Look behind and down before backing up to be sure of a clear path.
14. Slow down and use caution when making turns and crossing roads and sidewalks.
15. Use care when approaching blind corners, shrubs, trees, or other objects that may obscure vision.
16. Do not take your eyes off the road ahead.
Do not operate the machine with no hands.
17. Remember there is no such thing as a safe slope.
Travel on grass slopes requires particular care.
To guard against overturning, follow these instructions.
 - [1] Do not stop or start suddenly when going up or downhill.
 - [2] Engage clutch slowly, always keep machine in gear, especially when traveling downhill.
 - [3] Machine speeds should be kept low on slopes and during turns.
 - [4] Stay alert for humps and hollows and other hidden hazards.
18. Never use the machine on a slope with an angle of gradient that is greater than that specified or in a place where there is a danger of the machine slipping.
19. Use extra care while operating machine with a grass catcher or other attachments.
They can affect the stability of the machine.

Operation

1. Do not use the machine while you are tired or under the influence of drugs, alcohol or medication.
A moment of inattention while operating the machine may result in serious personal injury.
2. Do not operate the engine in a confined space where dangerous carbon monoxide fumes can collect.
3. Be sure all drives and shift are in neutral and parking brake is engaged before starting engine.
Only start engine from the operator's position.
Use seat belts if provided.
4. Do not change the engine governor settings or overspeed the engine.
Operating the engine at excessive speed may increase the hazard of personal injury.

Safety

20. Disengage drive to the cutting unit(s), when other than operating.
21. Do the following before leaving the operator's position.
 - [1] Stop on level ground.
 - [2] Disengage the all drives.
 - [3] Set the parking brake.
 - [4] Stop the engine.
 - [5] Remove the ignition key.
22. Stop the engine in the following conditions.
 - [1] Before refuelling.
 - [2] Before removing the grass catcher.
 - [3] Before making height or depth adjustment unless adjustment can be made from the operator's position.
 - [4] Before clearing blockages.
 - [5] Before checking, cleaning or working on the machine.
 - [6] After striking a foreign object or if an abnormal vibration occurs.
Inspect the machine for damage and make repairs before restarting and operating the equipment.
23. Reduce the throttle setting during engine run-out.
24. Do not direct discharge material toward anyone.
Avoid discharging material against a wall or obstruction.
Material may ricochet back toward the operator.
25. Take care when loading or unloading the machine into a trailer or a truck.
Load or unload the machine in a flat and safe place.
Before loading or unloading, set the parking brake on the truck or trailer, stop the engine, and chock the wheels.
When transporting the machine on a truck or a trailer, set the parking brake, stop the engine, and fasten the machine to the truck with a rope or other suitable restraining device that has sufficient strength.
When using a running board, select one with sufficient strength, length, and width and that will not cause the machine to slip.
26. Close the fuel valve before transporting the machine.

Maintenance

1. Never allow untrained personnel to service machine.
2. Implement the following work before adjusting, cleaning or repairing.
 - [1] Stop the machine on level ground.
 - [2] Disengage drive to the cutting unit(s).
 - [3] Lower the cutting unit(s) and/or attachment(s).
 - [4] Set the parking brake.
 - [5] Stop the engine.
 - [6] Remove the ignition key.
 - [7] Wait for all movement to stop.
3. Allow the engine/muffler to cool before checking/maintenance.
4. To reduce the fire hazard, keep hot parts such as the engine and silencer/muffler, battery compartment and fuel storage area free of grass, leaves, or excessive grease.
Clean up oil or fuel spillage.
5. Appropriately manage and correctly use the tools necessary for servicing or adjusting the machine.
6. Disconnect battery before making any repairs.
Disconnect the negative terminal first and the positive last.
Reconnect positive first and negative last.
7. Use jack stands to support components when required.
8. Keep hands and feet away from moving parts.
If possible, do not make adjustments with the engine running.
9. Make sure that parts such as wires are not touching each other and that their covers have not come off.
10. Keep all parts in good working condition and all hardware tightened.
Replace all worn or damaged decals.
11. Keep all nuts, bolts and screws tight to be sure the equipment is in safe working condition.
12. Carefully release pressure from components with stored energy.
13. Be sure to depressurize the hydraulic system before performing maintenance operations on it such as removing hydraulic equipment.

14. Check whether line connectors in the hydraulic system are properly tightened. Before applying hydraulic pressure, check the connections of the hydraulic pressure lines and the condition of the hoses.
15. When checking the hydraulic circuit for pinhole leaks or oil leakage from nozzles, do not use your hands.
Use items such as paper or corrugated cardboard to find leakage points.
Be extremely careful with high-pressure oil as it may pierce your skin, resulting in an injury.
If fluid is injected into the skin it must be surgically removed within a few hours by a doctor familiar with this form of injury or gangrene may result.
16. Use care when checking the cylinders/reels and bed knives.
Wear gloves and use caution when servicing them.
17. Be careful during adjustment of the machine to prevent entrapment of the fingers between moving blades and fixed parts of the machine.
18. On multi-cylinder/multi-reel machines, take care as rotating one cylinder/reel can cause other cylinders/reels to rotate.
19. Check the grass catcher frequently for wear or deterioration.
20. Charge batteries in an open well ventilated area, away from spark and flames.
Unplug charger before connecting or disconnecting from battery.
Wear protective clothing and use insulated tools.
21. If the fuel tank has to be drained, do this outdoors.
5. If the engine is provided with a shut-off valve, shut off valve while storing or transporting.
6. Do not store fuel near flames.
7. Swallowing engine coolant can cause injury or death; keep out of reach from children and pets.

Storage

1. When machine is to be parked, stored, or left unattended, lower the cutting unit(s) and/or attachment(s) unless a positive mechanical lock is provided.
2. Allow the engine to cool before storing in any enclosure.
3. Only cover the machine with a sheet after hot parts have sufficiently cooled down.
4. Never store the equipment with fuel in the tank inside a building where fumes may reach an open flame or spark.

Recycle and Waste Disposal Page 2-2

About RecyclePage 2-2

About Waste Disposal Page 2-2

Disposal

Disposal

Recycle and Waste Disposal

About Recycle

Recycling battery etc. is recommended for environmental conservation and economical use of resources.

It may be required by local laws.

About Waste Disposal

Make sure that waste generated when servicing or repairing the machine is disposed of in accordance with local regulations. (e.g. waste oil, antifreeze, rubber products, and wires etc.)

Specifications Page 3-2

SpecificationsPage 3-2

Mower UnitsPage 3-3

Sound Pressure Level Page 3-3

Sound Power Level Page 3-3

Vibration Level Page 3-3

Carbon Dioxide (CO₂) EmissionsPage 3-4**Names of Each Section Page 3-4****Regulation DecalsPage 3-7**

Positions of Regulation Decals Page 3-7

Description of Regulation Decals Page 3-7

Safety Signs and Instruction SignsPage 3-11

About Safety Signs and Instruction

Signs Page 3-11

Positions of Safety Decals and

Instruction Decals Page 3-11

Description of Safety Decals and

Instruction Decals Page 3-12

Operation Decals Page 3-16

Positions of Operation Decals Page 3-16

Description of Operation Decals Page 3-17

Product Overview

Specifications

Specifications

Model		LM351				
Name		3-Unit Reel Mower				
Mower unit type	Type	Roller type		Wheel type		
	#1	30 in		←		
	#2 · #3	26 in		←		
Dimensions	Total length		290 cm	114.17 in	298 cm	117.32 in
	Total width	During operation	208 cm	81.89 in	←	←
		During transport	187 cm	73.62 in	←	←
	Total height	ROPS	193 cm	75.98 in	←	←
Steering wheel		129 cm	50.79 in	←	←	
Weight	Machine (empty fuel tank)	with ROPS	1065 kg	2347.92 lb	←	←
	Grass catchers (for one machine)		17 kg	37.48 lb	-	-
Minimum turning radius			282 cm	111.02 in	←	←
Engine	Model		Kubota D1105-E4B		←	
	Type		Vertical water-cooled 4-cycle diesel engine		←	
	Total displacement		1,123 cm ³ (1.123 L)	68.52 cu.in.	←	←
	Maximum output		-		-	
	Rated output		18.5 kW (25.2 PS)/3,000 rpm		←	
Fuel tank capacity			Diesel 38.0 dm ³ (38.0 L)	Diesel 10.04 U.S.gals	←	←
Fuel consumption			289 g/kW · h (rated output)	213 g/PS · h (rated output)	←	←
Engine oil capacity			3.0 dm ³ (3.0 L)	0.79 U.S.gal.	←	←
Coolant volume			6.0 dm ³ (6.0 L)	1.59 U.S.gal.	←	←
Hydraulic tank capacity			24.0 dm ³ (24.0 L)	6.34 U.S.gal.	←	←
Transmission oil capacity			-		-	
Operating width (Mowing width)			184 cm	72.44 in	←	←
Operating height (Mowing height)			10.0 - 46.0 mm	0.39 - 1.81 in	20.0 - 50.0 mm	0.79 - 1.97 in
Number of Blades			5,7		5	
Drive	Traveling		HST (Full time 4WD)		←	
	Mowing		Hydraulic		←	
Speed (HST)	Forward		0 - 15.5 km/h	0 - 9.63 mph	←	←
	Reverse		0 - 8.0 km/h	0 - 4.97 mph	←	←
Speed (Mechanical)			-		-	

Product Overview

Efficiency		14,720 m ² /h (10.0 km/h x mowing width x 0.8)	3.60 acres/hour (6.21 mph x mowing width x 0.8)	←	←
Maximum inclination for operation		15 degrees		←	
Tire size	Front wheel	23 x 10.50 - 12		←	
	Rear wheel	18 x 8.50 - 10		←	
Tire pneumatic pressure	Front wheel	120 kPa (1.2 kgf/cm ²)	17 psi	←	←
	Rear wheel	120 kPa (1.2 kgf/cm ²)	17 psi	←	←
Battery		75D23L		←	
Engine plug		-		-	

The factory default maximum engine rpm is 3,100 rpm.

Mower Units

Baroness mower unit that can fit this machine is the model marked with a circle in the "Attachable unit" column.

LM351

Model		Attachable unit	Remarks
LH52	22 in	-	
LH62	22 in	-	
LH66	26 in	-	
LS60	30 in	○	
LS62	22 in	-	
LS66	26 in	○	
VM60	30 in	○	
VM62	22 in	-	
VM66	26 in	○	

Sound Pressure Level

Sound Pressure Level

This machine was confirmed to have a continuous A-weighted sound pressure level of 88 dB by measuring identical machines in accordance with the procedure specified in ISO5395-1:2013.

Sound Power Level

Sound Power Level

This machine was confirmed to have a sound power level of 105dB by measuring identical machines in accordance with the procedure specified in ISO5395-1:2013.

Vibration Level

Hand-Arm Vibration

This machine was confirmed not to exceed a vibration level of 2.5 m/s² to hands and arms by measuring identical machines in accordance with the procedure specified in ISO 5395-1:2013.

Uncertainty K = 0.4 m/s²

Whole Body Vibration

This machine was confirmed not to exceed a vibration level of 0.5 m/s² to the whole body by measuring identical machines in accordance with the procedure specified in ISO 5395-1:2013.

Uncertainty K = 0.1 m/s²

Product Overview

Carbon Dioxide (CO₂) Emissions

For the CO₂ value on the engine of this machine, refer to the engine's owner's manual.

Names of Each Section

Overall View A

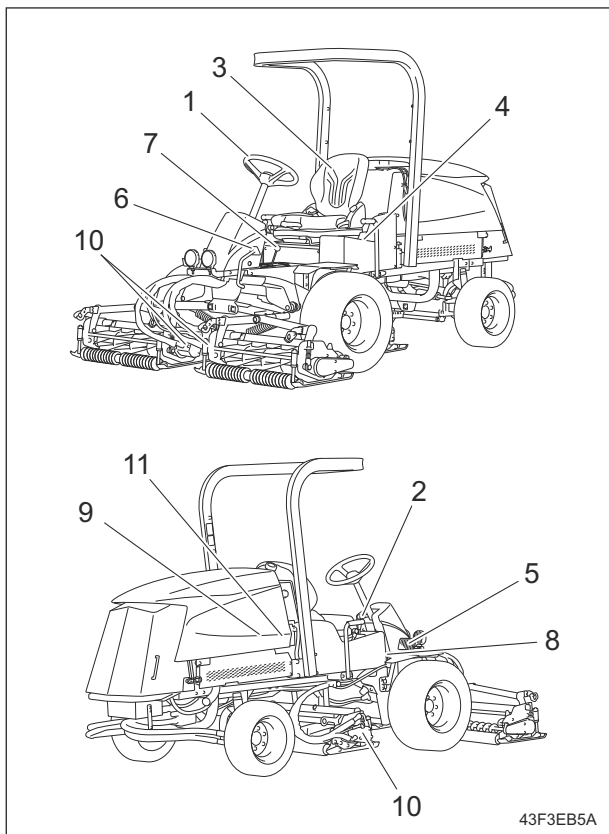

Names of Each Section_001

1	Steering wheel
2	Tilt lever
3	Seat
4	USB socket
5	Traveling pedal
6	Brake pedal
7	Parking brake lever
8	Stop valve
9	Reel forward/reverse switch
10	Reel rotation/stop switching lever
11	Hour meter

Overall View B

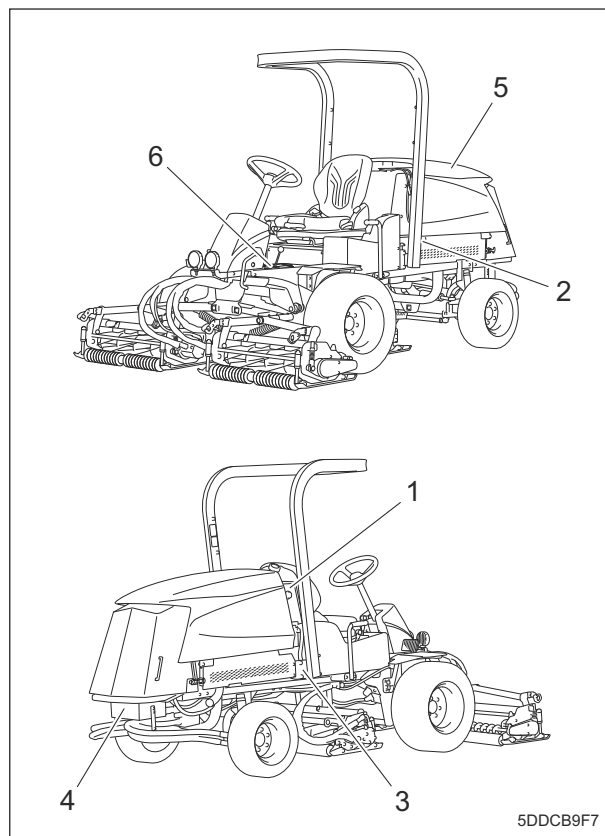

Names of Each Section_002

1	Fuel tank
2	Fuel filter
3	Water separator
4	Battery
5	Hood
6	Center cover

Product Overview

Overall View C

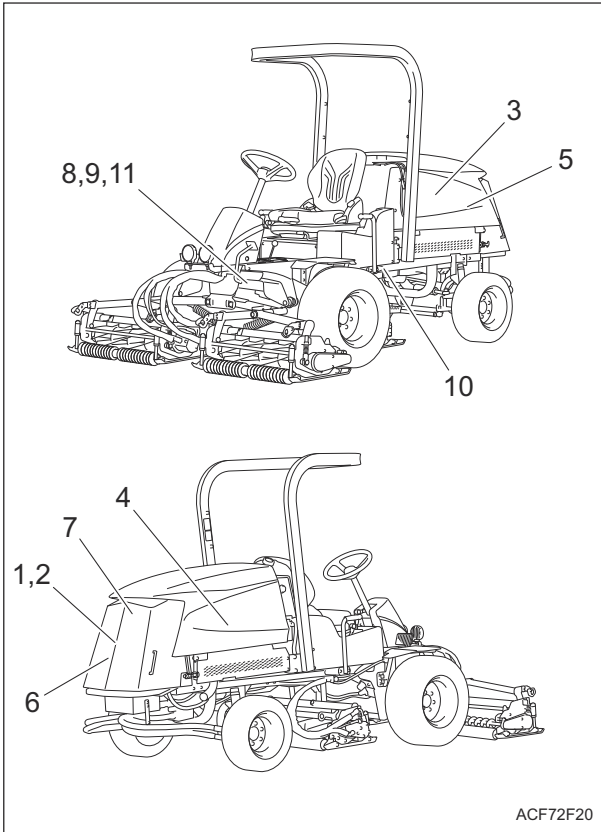

Names of Each Section_003

1	Radiator
2	Radiator cover
3	Engine
4	Engine oil filter
5	Reserve tank
6	Oil cooler
7	Air cleaner
8	Hydraulic tank
9	Air breather
10	Hydraulic oil line filter
11	Hydraulic oil suction filter

Overall View D

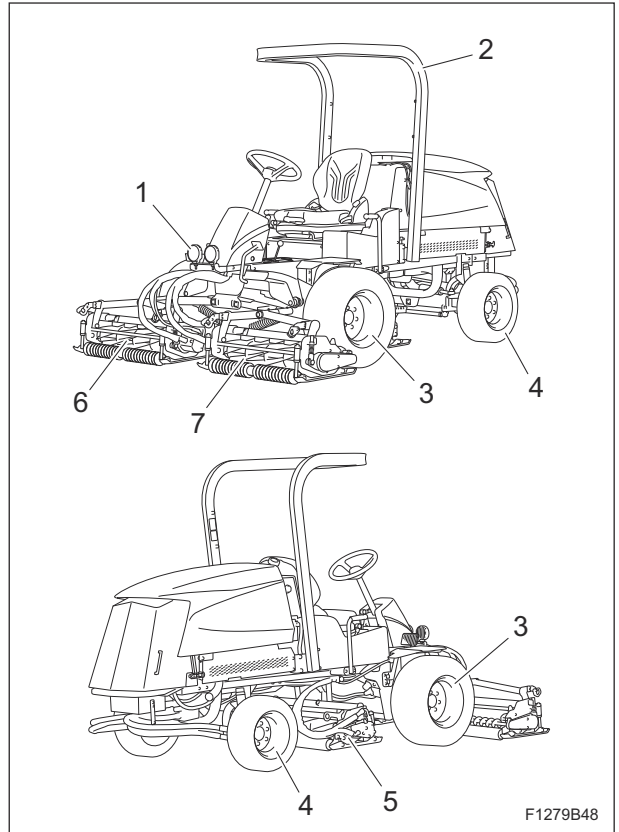

Names of Each Section_004

1	Light
2	ROPS
3	Front tire
4	Rear tire
5	Mower unit #1
6	Mower unit #2
7	Mower unit #3

Product Overview

Product Overview

Operation panel

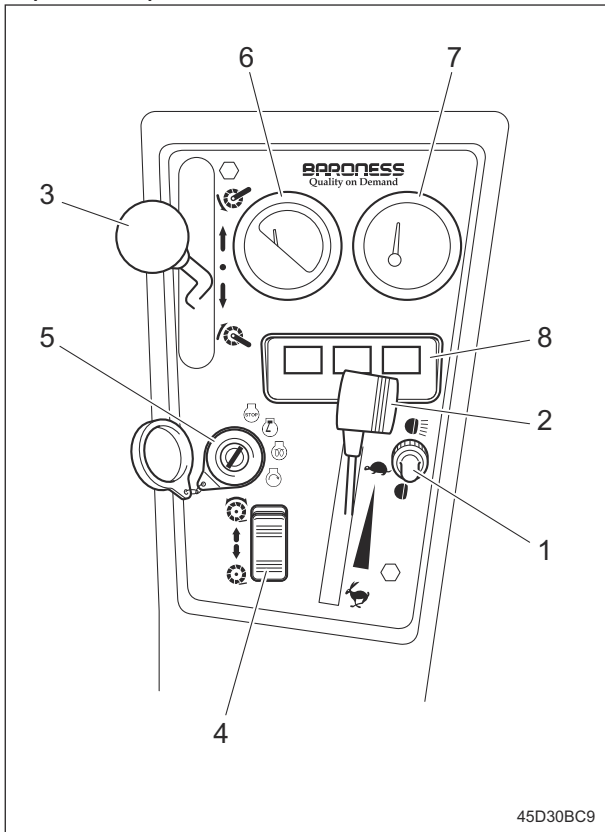

Names of Each Section_005

1	Light switch
2	Throttle lever
3	Mower unit up/down lever
4	Reel rotation switch
5	Key switch
6	Water temperature gauge
7	Fuel gauge
8	Pilot lamp

Regulation Decals

Positions of Regulation Decals

Main vehicle

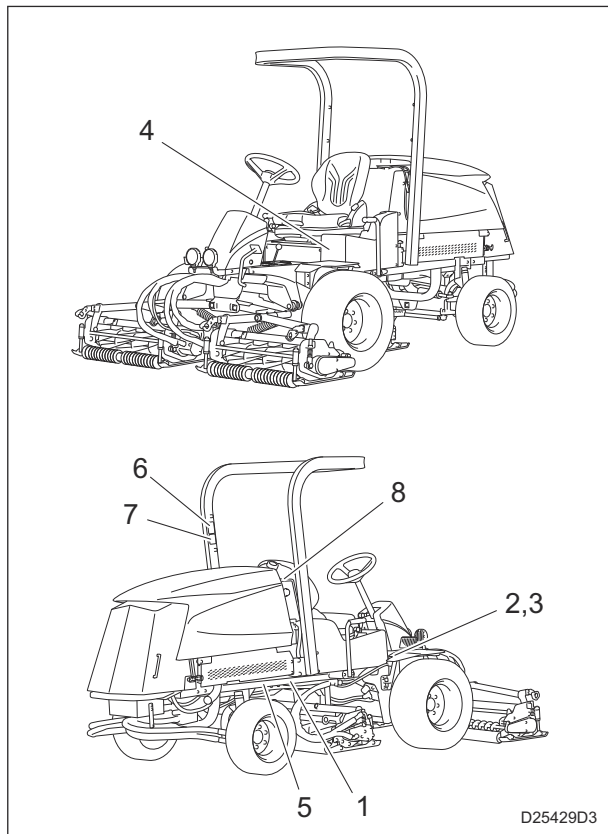

Positions of Regulation Decals_001

1	Serial number plate
2	Specification decal
3	CE Mark
4	Noise emission decal
5	Year of manufacture decal
6	ROPS compliance decal
7	ROPS caution decal
8	Diesel instruction decal

Battery

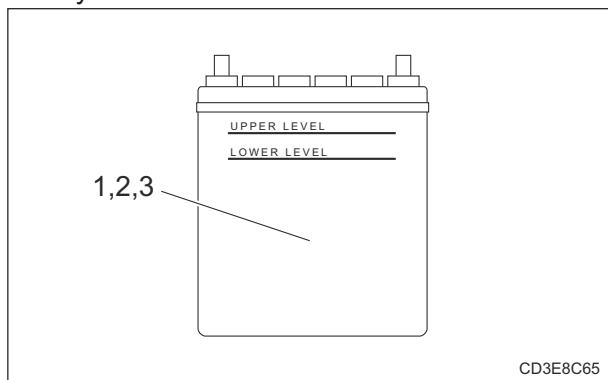

Positions of Regulation Decals_001

1	Battery capacity decal
2	EU battery regulation decal
3	Recycle decal

Description of Regulation Decals

Serial Number Plate

The following information is written on the serial number plate.

1. Model
2. Serial number
3. Registered trademark
4. Manufacturer

- Company name
- Postal address/Address
- Website

Contact the manufacturer via the contact form on the website.

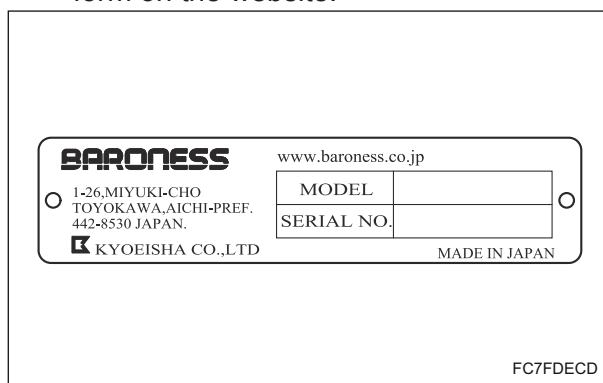

Serial Number Plate_001

Specification Decal

(For EU)

The Specification decal indicates the model and weight, etc.

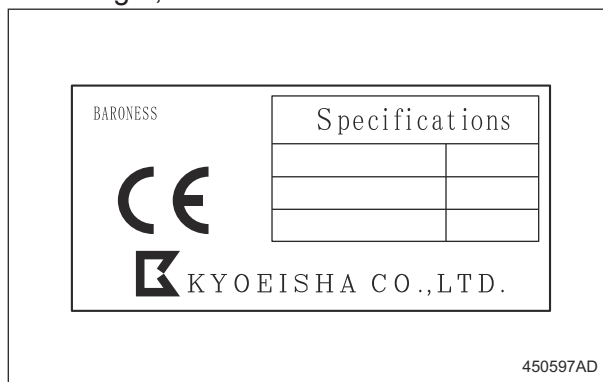

Specification Decal_001

Product Overview

CE Mark

(For EU)
CE mark indicates that the machine sold in the EU nations complies with the EU requirements.

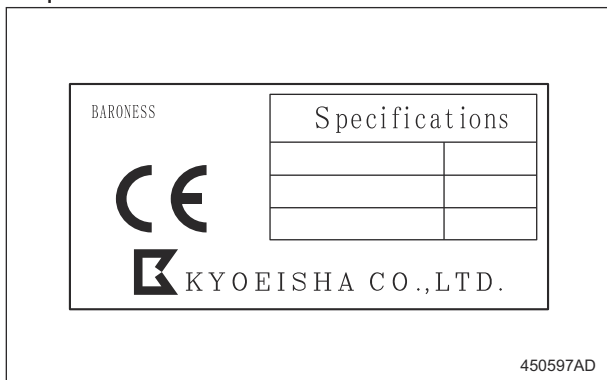

CE Mark_001

Year of Manufacture Decal

(For EU)
The year of manufacture decal indicates the year when this machine was manufactured.

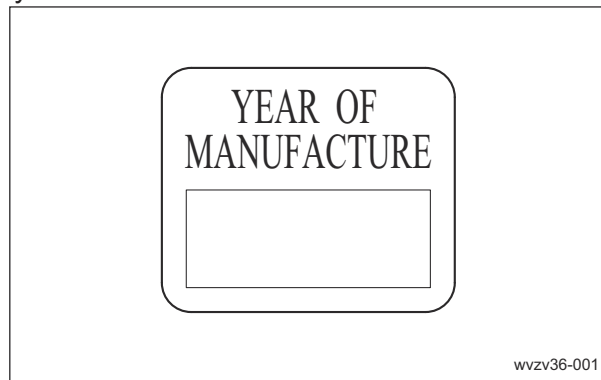

Year of Manufacture Decal_001

Noise Emission Decal

(For EU)
The noise emission decal indicates the sound power level determined by measuring identical machines in accordance with the procedure specified in the regulations of EU.

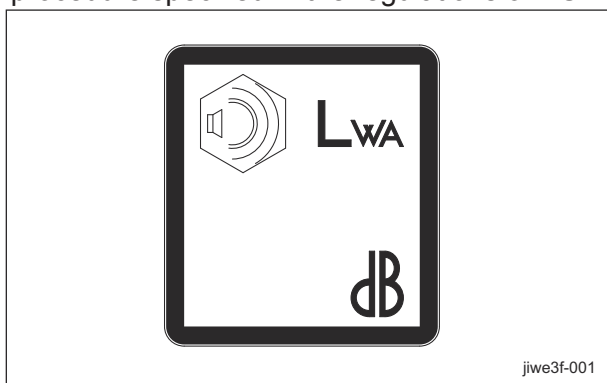

Noise Emission Decal_001

ROPS Compliance Decal

The ROPS compliance decal indicates the manufacturer, model, etc., in accordance with International Standard ISO 21299:2009.

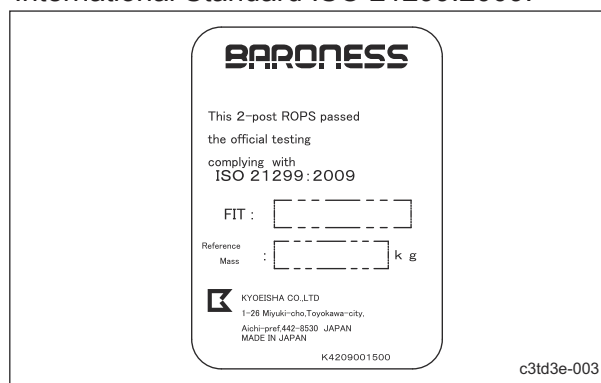

ROPS Compliance Decal_001

ROPS Caution Decal

ROPS caution decal describes the following caution messages.

- Replace damaged ROPS.
- Do not repair or revise.

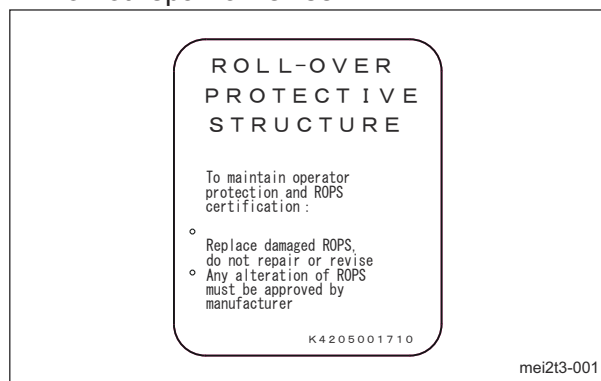

ROPS Caution Decal_001

Indicating Diesel Fuel Decal

(for USA)

It indicates the fuel to be used.

Use low sulfur or ultra-low sulfur diesel fuel (sulfur-free diesel fuel).

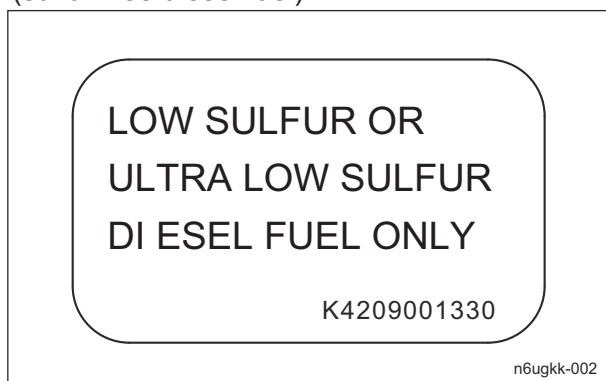

Indicating Diesel Fuel Decal_001

Battery Capacity Decal

(For EU)

The battery capacity decal indicates the capacity by 20HR and CCA.

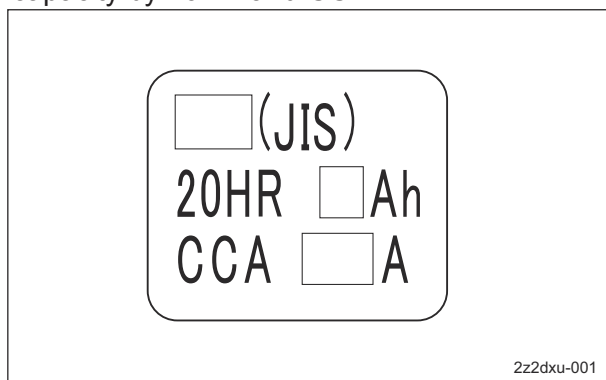

Battery Capacity Decal_001

EU Battery Regulation Decal

(For EU)

The EU battery regulation decal indicates compliance with the EU battery regulation.

- The following information about the battery manufacturing company is written in the decal.
 - Company name
 - Address
 - Website URL
- You can scan the QR code with your smartphone to access the corresponding battery information. (*QR Code is a registered trademark of DENSO WAVE INCORPORATED.)
- CE mark indicates that the battery installed in a machine sold in the EU nations complies with the EU requirements.

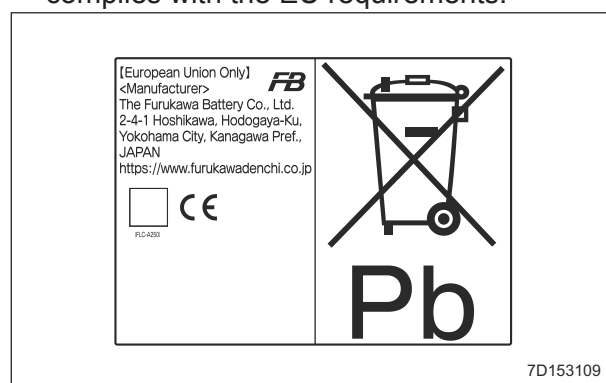

EU Battery Regulation Decal_001

Product Overview

Recycle Decal

Recycle Decal illustrates Recycle Mark in accordance with local regulation.

(For EU)

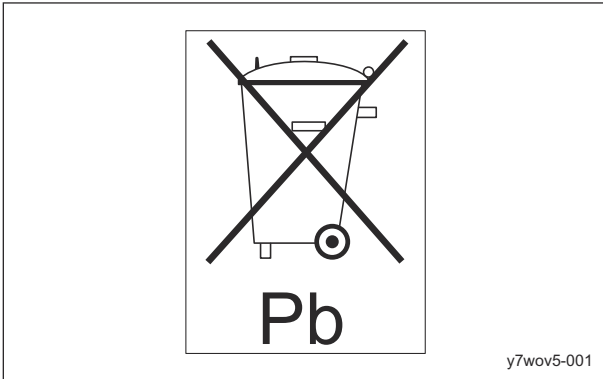

Recycle Decal_001

(For USA)



Recycle Decal_002

Safety Signs and Instruction Signs

About Safety Signs and Instruction Signs

Important

Safety decals and instruction decals are attached to this product. Make sure that they are preserved in their entirety. If they are damaged, become dirty, or peel off, replace them with new ones.

Part numbers for decals that need to be replaced are listed in the parts catalog. Order them from a Baroness dealer or Kyoeshia.

Positions of Safety Decals and Instruction Decals

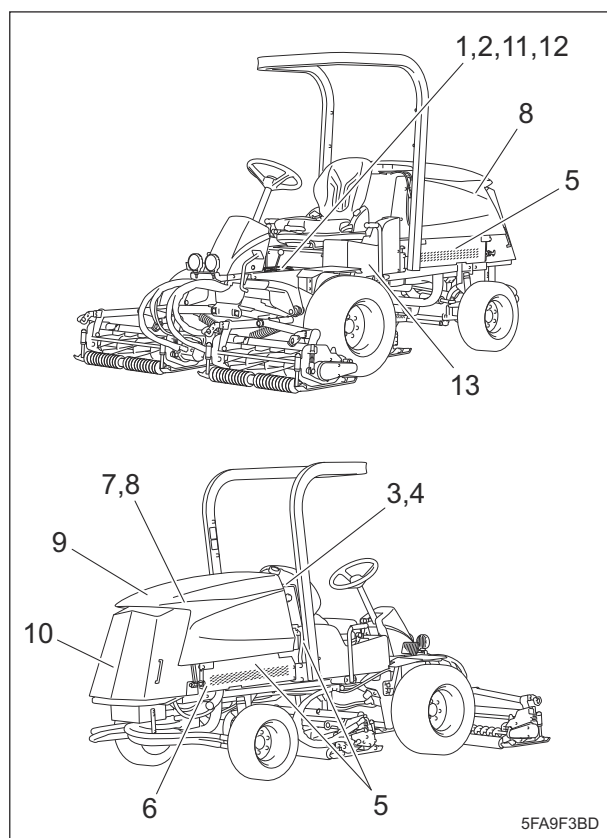

Positions of Safety Decals and Instruction Decals_001

1	Operation decal 2
2	Hydraulic oil decal
3	Diesel fuel filler port decal
4	Fire prohibited decal
5	Caution for getting pinched decal
6	Caution to hot parts decal
7	Caution to hot parts decal
8	Caution to rotating object decal
9	Caution for spouting coolant decal
10	Decal on prohibiting high-pressure washing
11	DO NOT STEP caution decal
12	Caution to noise decal
13	Decal on indicating tire pressure

Product Overview

Description of Safety Decals and Instruction Decals

Decal for Operation 2

Decal for operation 2
LM2400-0918Z0

1.



Warning

Read the Owner's Operating Manual.

2.



Warning

Apply the parking brake, stop the engine, remove the ignition key, and then leave the machine.

3.



Caution

Thrown objects - Be sure that people around the machine keep a safe distance away.

4.

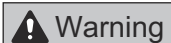

Warning

May cut your hand or leg - Keep hands and feet away from moving parts.

5.



Warning

Be careful of exhaust emissions.

6.

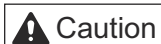

Caution

Rollover - Do not work on slopes of 15 degrees or more.
When you descend a slope, lower the mower units and then drive at low speed.
For ROPS equipped machine, fasten your seatbelt.

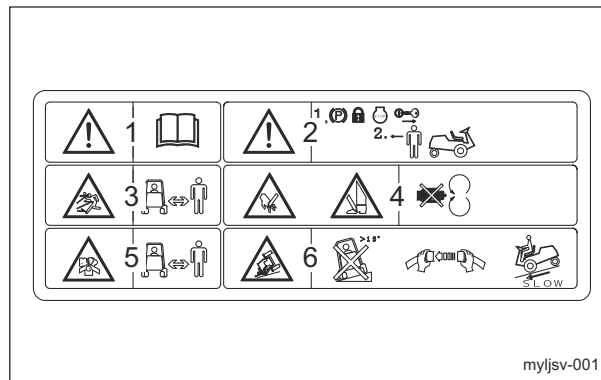

Decal for Operation 2_001

Hydraulic Oil Decal

K4209001390

Decal, hydraulic oil

Read the owner's operating manual.

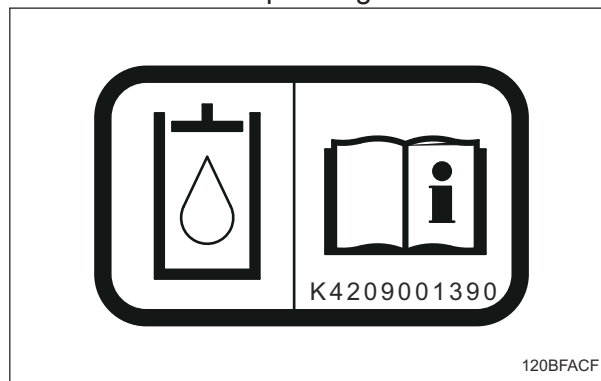

Hydraulic Oil Decal_001

Diesel Fuel Filler Port Decal

K4209001000
DECAL, DIESEL OIL FILLER PORT
Use diesel fuel.

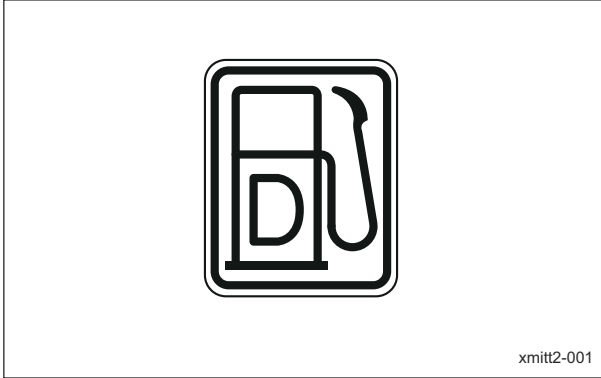

Diesel Fuel Filler Port Decal_001

Fire Prohibited Decal

K4205001940
Decal, fire prohibited

Warning

Keep away from fire.



Fire Prohibited Decal_001

Caution for Getting Pinched Decal

K4205001930
DECAL, CAUTION GETTING CAUGHT
HANDS/FEET

Caution

May get pinched - There is a risk of being pinched.

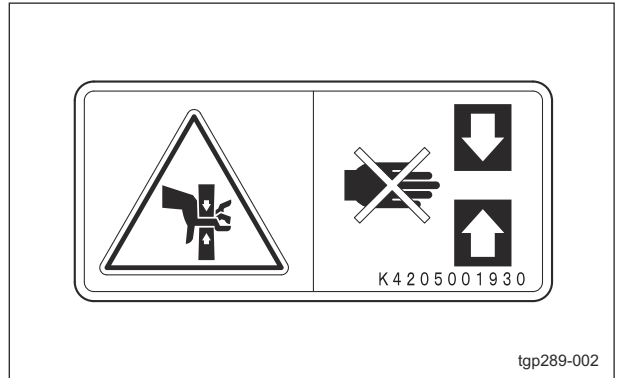

Caution for Getting Pinched Decal_001

Caution for High Temperatures Decal

K4205001920
Decal, caution for high temperatures

Caution

High temperature - Do not touch. Otherwise, you will get burned.



Caution for High Temperatures Decal_001

Product Overview

Caution to Hot Parts Decal

K4205001540

Decal for caution to hot parts

Caution

High temperature - Do not touch. Otherwise, you will get burned.



xekv4l-001

Caution to Hot Parts Decal_001

Caution for Spouting Coolant Decal

K4205001970

Decal, caution for spouting coolant

Caution

Caution for spouting coolant - Do not open while hot.
High temperature - Do not touch. Otherwise, you will get burned.



K4205001970

pwb8d2-001

Caution for Spouting Coolant Decal_001

Caution to Rotating Object Decal

K4205001530

Decal, caution to rotating object

Warning

Watch for rotating parts - Keep your hands away from the belts while the engine is running.

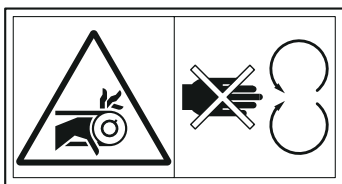

qwsqzx-001

Caution to Rotating Object Decal_001

Decal on Prohibiting High Pressure Washing

K4205002390

Decal, prohibition of high pressure washing
Do not wash with high pressure.



7C94402B

Decal on Prohibiting High Pressure Washing_001

DO NOT STEP Caution Decal

K4209001340
Decal, caution "DO NOT STEP"



DO NOT STEP Caution Decal_001

Caution to Noise Decal

K4205001330
DECAL, CAUTION TO NOISE

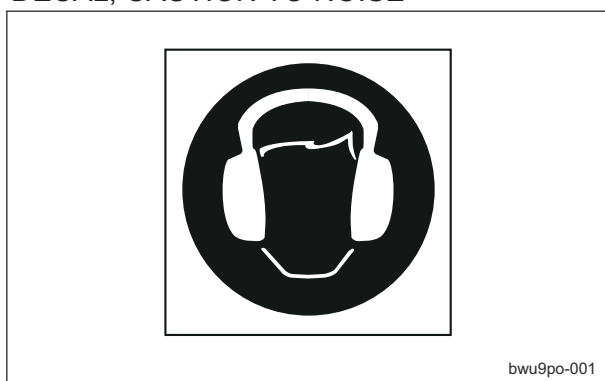

Caution to Noise Decal_001

Decal on Indicating Tire Pressure

LM351--0925Z0
Decal, indicating tire pressure
This indicates tire pressure of this machine.

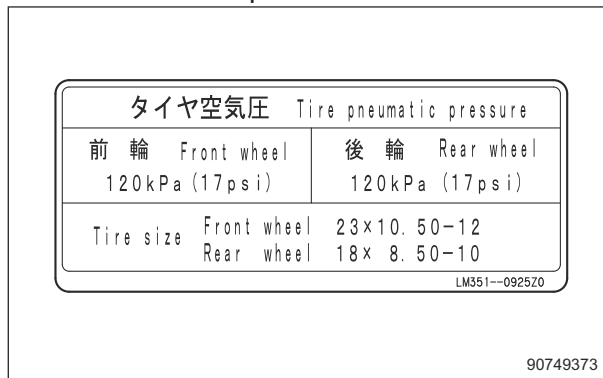

Decal on Indicating Tire Pressure_001

Product Overview

Operation Decals

Positions of Operation Decals

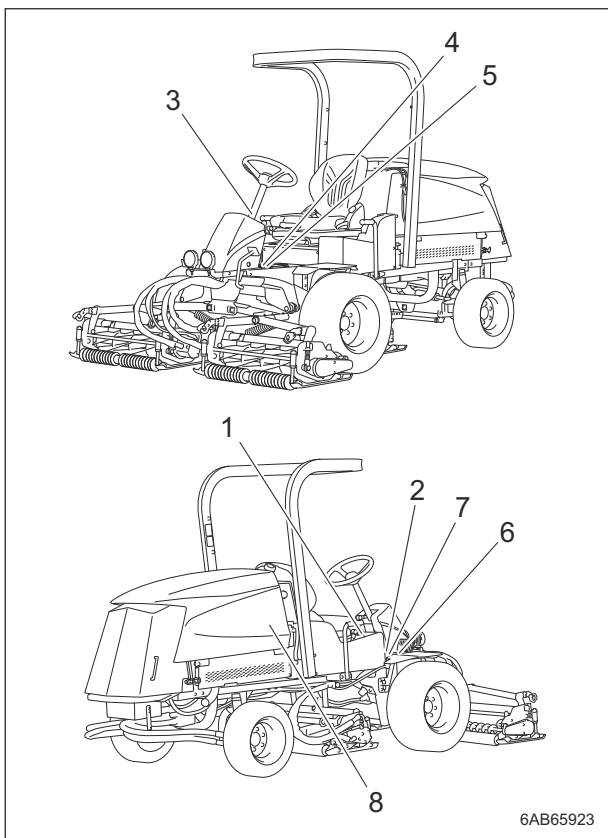

Positions of Operation Decals_001

(#10001 - 10163, #10170 - 10175)

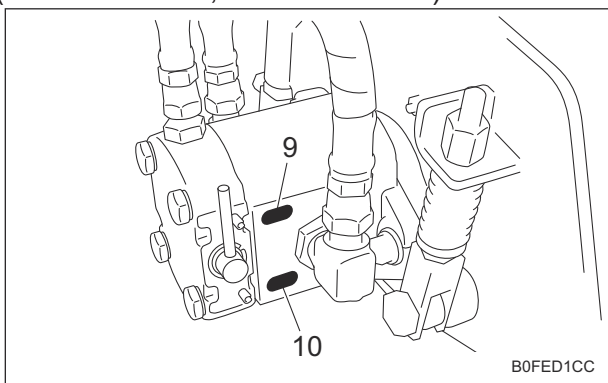

Positions of Operation Decals_002

(#10164 - 10169, #10176-)

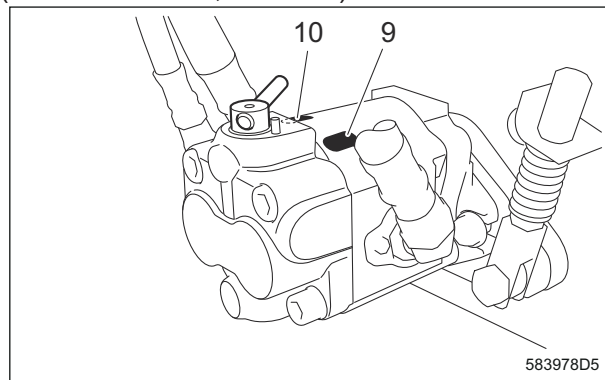

Positions of Operation Decals_003

1	Operation decal
2	Stop valve operation decal
3	Tilt steering decal
4	Parking brake decal
5	BRAKE decal
6	FORWARD decal
7	BACKWARD decal
8	Lapping switch decal
9	Reel rotation decal
10	Reel stop decal

Description of Operation Decals

Operation Decal

LM351--0924Z0
Decal, operation

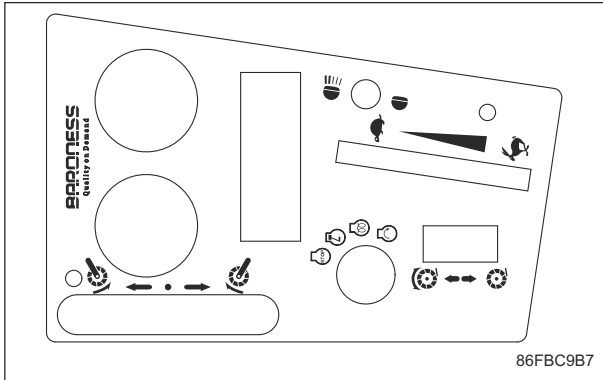

Operation Decal_001

Key Switch Mark

Key switch mark
This indicates the key switch positions.

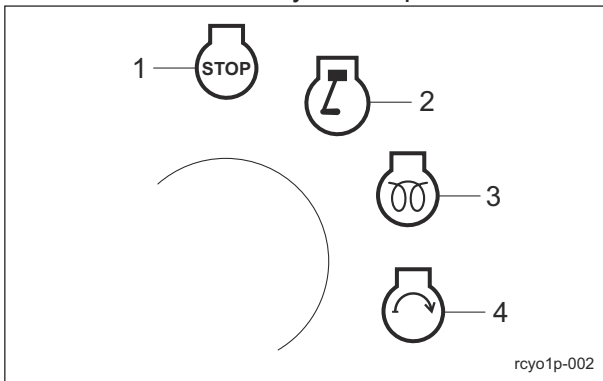

Key Switch Mark_001

1	OFF
2	ON
3	GLOW
4	START

Engine Rotation Mark

Engine rotation mark
This indicates high/low speed of the engine rotation.

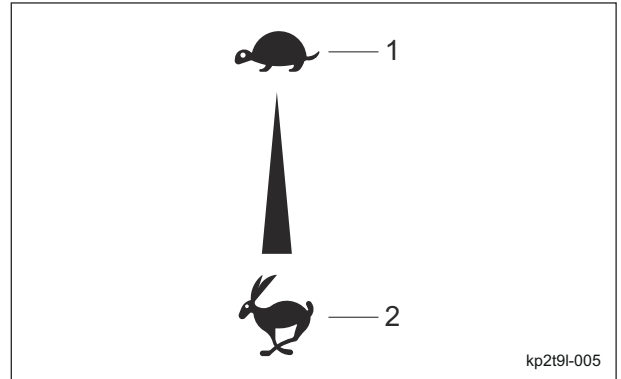

Engine Rotation Mark_001

1	Low speed
2	High speed

Light Switch Mark

Note:
Depending on the specifications, this function may not be available.
Light switch mark
It illustrates ON/OFF of the light.

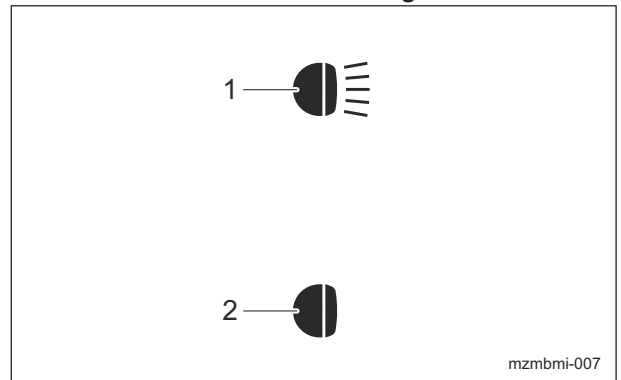

Light Switch Mark_001

1	ON
2	OFF

Product Overview

■ Reel Rotation Mark

Reel rotation mark
It illustrates Rotation/Stop of the reel cutter (cutting cylinder).

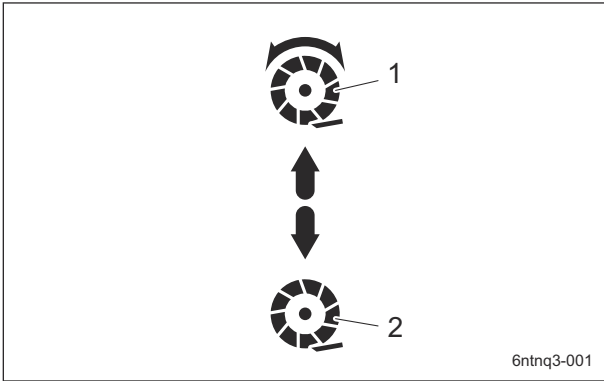

Reel Rotation Mark_001

1	Rotation
2	Stop

Stop Valve Operation Decal

K4203001290
Stop valve operation decal
It illustrates Stop/Open of the stop valve.

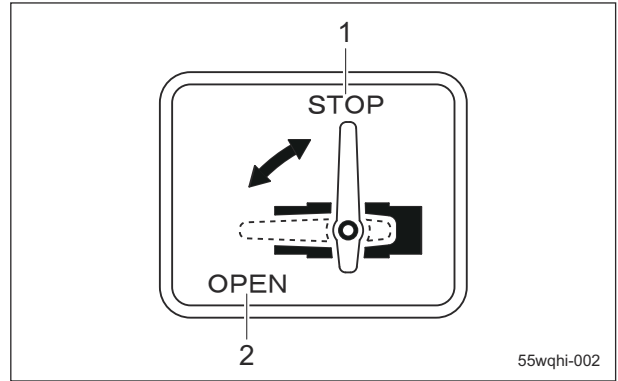

Stop Valve Operation Decal_001

1	Stop
2	Open

■ Mower Unit Up/Down Decal

Decal, mower unit up/down
This indicates the Up/Down positions of the mower unit.

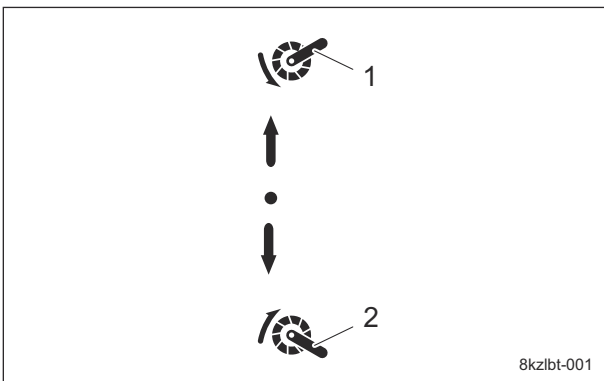

Mower Unit Up/Down Decal_001

1	Down
2	Up

Tilt Steering Decal

K4203001560
Decal, tilt steering
This illustrates the tilt directions of the steering wheel and the locked/free positions.

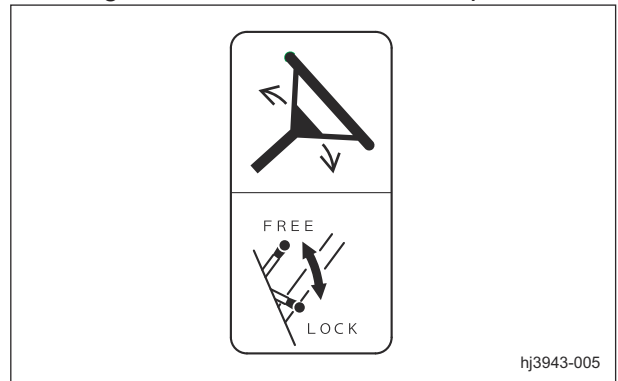

Tilt Steering Decal_001

Parking Brake Decal

K4203001340
 Parking brake decal
 This shows how to lock and release the parking brake.

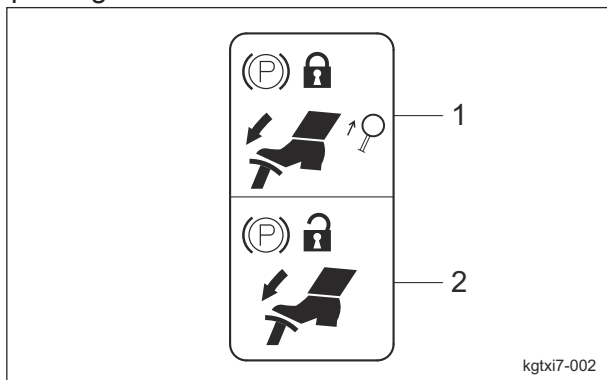

Parking Brake Decal_001

1	Lock
2	Release

BRAKE Decal

K4203001450
 Decal, BRAKE
 This indicates brake.



BRAKE Decal_001

FORWARD Decal

K4203001430
 Decal, FORWARD
 This indicates forward travel.



FORWARD Decal_001

BACKWARD Decal

K4203001440
 Decal, BACKWARD
 This indicates backward travel.



BACKWARD Decal_001

Product Overview

Lapping Switch Decal

LM331--0556Z0

Lapping switch decal

This indicates the ON/OFF positions for back lapping.

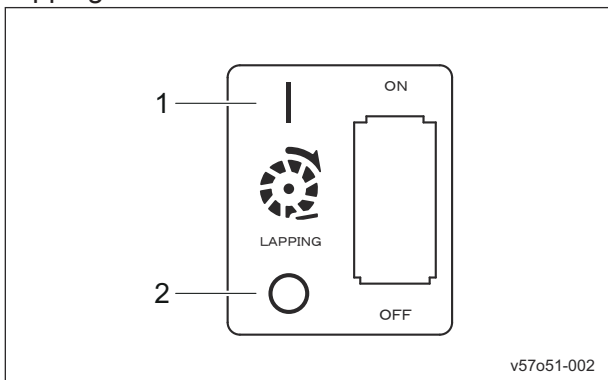

Lapping Switch Decal_001

1	ON (back lapping rotation)
2	OFF (mowing rotation)

Reel Stop Decal

K4203001310

Decal, reel stop

This indicates stop of the reel cutter (cutting cylinder).

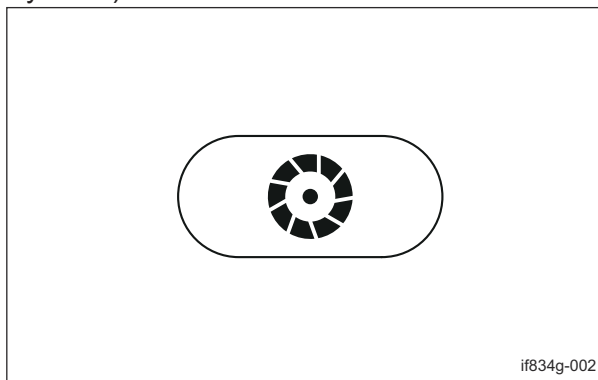

Reel Stop Decal_001

Reel Rotation Decal

K4203001300

Decal, reel rotation

This indicates rotation of the reel cutter (cutting cylinder).

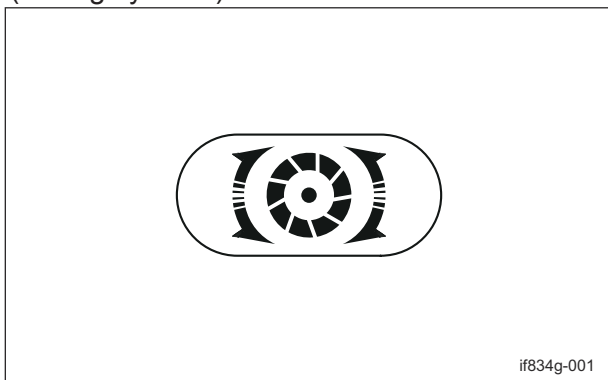

Reel Rotation Decal_001

Description of Functions

Light Switch	Page 4-2
Throttle Lever	Page 4-2
Mower Unit Up/Down Lever	Page 4-2
Reel Rotation Switch	Page 4-3
Stop Valve	Page 4-3
Reel Forward/Reverse Switch	Page 4-4
Key Switch	Page 4-4
USB Socket	Page 4-4
Tilt Lever	Page 4-5
Traveling Pedal	Page 4-5
Pedal Stopper	Page 4-5
Brake Pedal	Page 4-6
Parking Brake Lever	Page 4-6
Reel Rotation/Stop Switching Lever	Page 4-6
Instruments on the Operation Panel	Page 4-7
Water Temperature Gauge	Page 4-7
Fuel Gauge	Page 4-7
Pilot Lamps	Page 4-8
Hour Meter	Page 4-9
Safety Device	Page 4-9
Interlock System	Page 4-9
Warning Mechanisms	Page 4-9
Warning Buzzer	Page 4-9

Description of Functions

Light Switch

⚠ Caution

The lights provide auxiliary lighting. Do not travel or operate the machine at night or under poor visibility.

1. Set the light switch to the "ON" position to turn on the LED light.
2. Set the light switch to the "OFF" position to turn off the LED light.

Note:

The lights do not turn on when the ignition key is set to the "OFF" position.

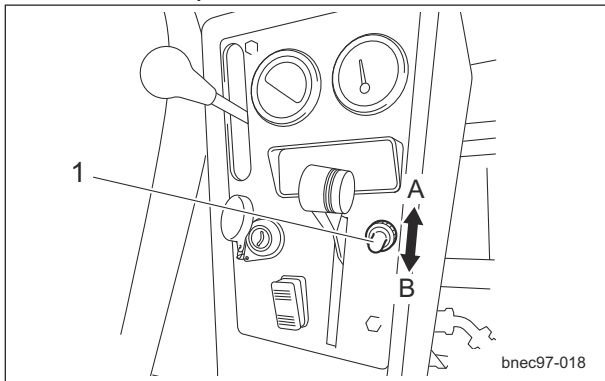

Light Switch_001

1	Light switch
A	ON
B	OFF

Throttle Lever

The throttle lever enables you to adjust the engine rpm.

1. Shift the throttle lever to the "High speed" position to increase the engine rpm.
2. Shift the throttle lever to the "Low speed" position to reduce the engine rpm.

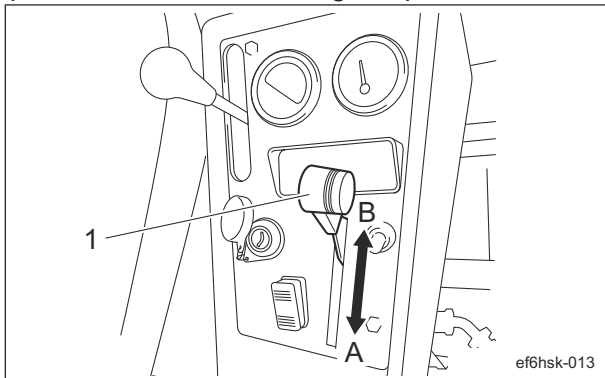

Throttle Lever_001

1	Throttle lever
A	High speed
B	Low speed

Mower Unit Up/Down Lever

⚠ Caution

Before raising or lowering the mower units, make sure that there are no people around the machine.

⚠ Caution

Be careful since shifting the mower unit up/down lever to the "DOWN" position lowers the mower units, even while the engine is stopped.

Important

Before operating the mower unit up/down lever, be sure to set the stop valve to the "Open" position.

The mower unit up/down lever raises or lowers the mower units.

1. Shift the lever to the "DOWN" position to lower all the mower units.
2. Shift the lever to the "UP" position to raise all the mower units.

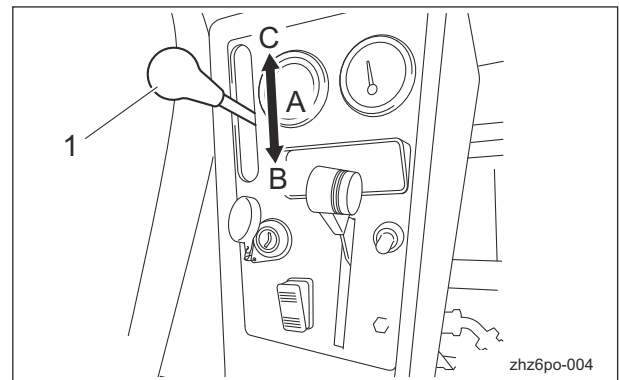

Mower Unit Up/Down Lever_001

1	Mower unit up/down lever
A	Neutral
B	Up
C	Down

Description of Functions

Note:
Shifting mower unit up/down lever to the neutral position or raising the mower units stops the reel cutter (cutting cylinder) rotating even when the reel rotation switch is set to the "Rotate" position.

Reel Rotation Switch

Caution

The reel rotation switch must be set to the "Rotate" position just before you start cutting work.
It must be set to the "Stop" position except when cutting work.

The reel rotation switch operates rotation of the reel cutters (cutting cylinders) of the mower units.

1. Set the reel rotation switch to the "Rotate" position to rotate the reel cutters (cutting cylinders).
2. Set the reel rotation switch to the "Stop" position to stop rotating the reel cutters (cutting cylinders).

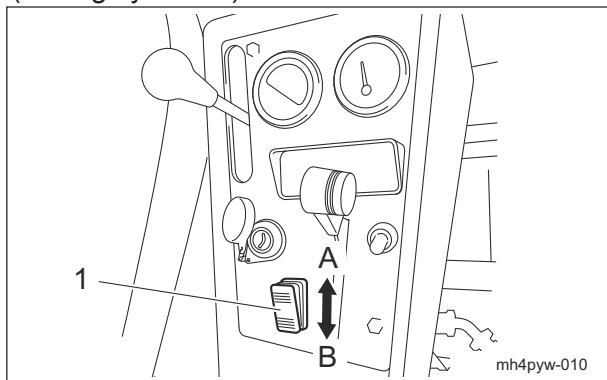

Reel Rotation Switch_001

1	Reel rotation switch
A	Rotate
B	Stop

Stop valve prevents all raised mower units from falling.

Setting the stop valve to the "Stop" position while the mower units raised keeps the mower units in the raised position.

Setting the stop valve to the "Stop" position while the mower units lowered keeps the mower units in the lowered position.

Note:
When the stop valve is set to the "Stop" position, mower units will not be raised or lowered even if mower unit up/down lever is operated.

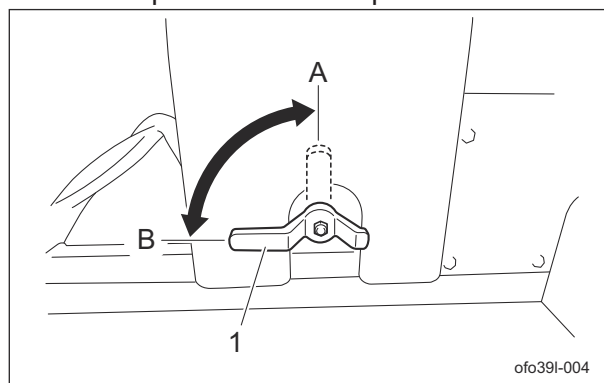

Stop Valve_001

1	Stop valve
A	Stop
B	Open

Stop Valve

Caution

When you move the machine or when you stop the engine with the mower units raised, be sure to set the stop valve to the "Stop" position.

Description of Functions

Reel Forward/Reverse Switch

Important
Do not switch the reel forward/reverse switch to the "ON" or "OFF" position while the reel cutter (cutting cylinder) is rotating. Otherwise, the hydraulic system will malfunction.

Important
If the reel rotation switch is not set to the "Rotate" position, the reel cutter (cutting cylinder) will not rotate.

The reel forward/reverse switch switches the rotation direction of the reel cutter (cutting cylinder).

1. When the reel forward/reverse switch is set to the "OFF (Forward)" position, the reel cutters of all mower units rotate for cutting work (forward rotation).
2. When the reel forward/reverse switch is set to the "ON" position, the reel cutters of all mower units rotate for back lapping (reverse rotation).

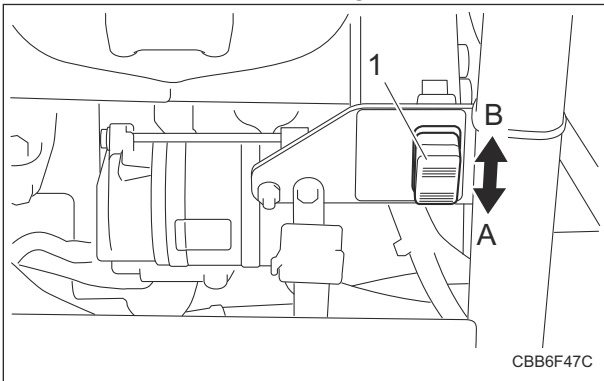

Reel Forward/Reverse Switch_001

1	Reel forward/reverse switch
A	OFF (Forward)
B	ON (Reverse)

Key Switch

The key switch is a lock for inserting the ignition key.

This is used for starting, running or stopping the engine by turning the ignition key to change the key switch position.

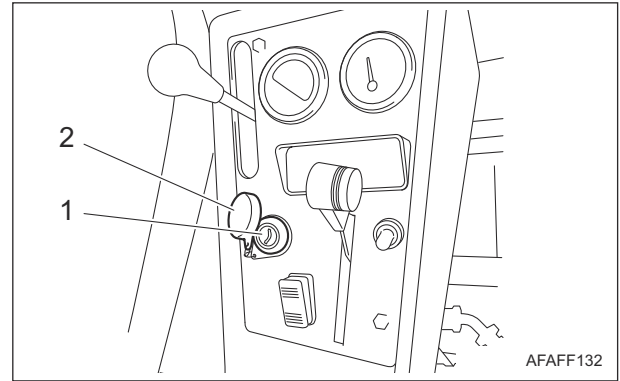

Key Switch_001

1	Key switch
2	Cap

USB Socket

Important

Do not use the USB socket in rainy weather to avoid malfunction of devices.

The USB socket can be used to charge or power devices that can be connected via USB, such as smartphones.

When the ignition key is set to the "ON" position, it is energized and the indicator on the USB port glows blue.

1. Switch the ignition key to the "ON" position.
2. Open the protective cover.

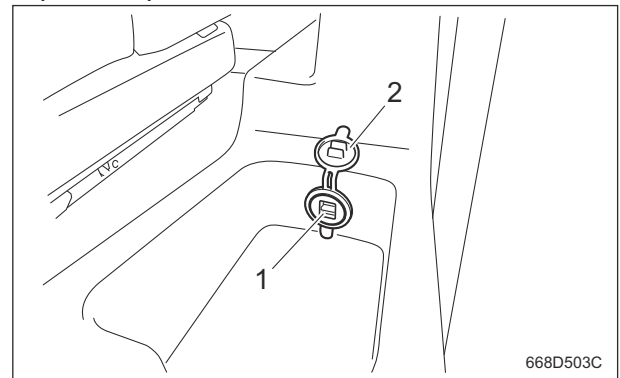

USB Socket_001

1	USB port
2	Protective cover

Description of Functions

3. Check the device to be connected.
The maximum output power is DC5 V 2.1 A Max for each port.
The shape of the ports is Standard-A (Type-A) for each port.

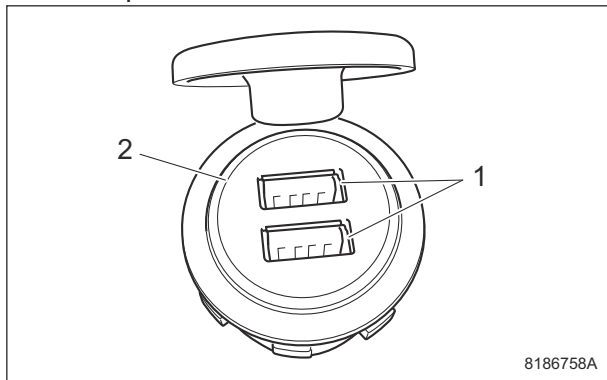

USB Socket_002

1	2.1 A
2	Indicator

4. Insert the USB cable into the USB port.
The indicator glows blue when energized.
5. Close the protective cover after use.

Tilt Lever

1. Shift the tilt lever to the "Release" position to release the lock and adjust the position of the steering arm.
2. Shift the tilt lever to the "Lock" position to lock the position of the steering arm.

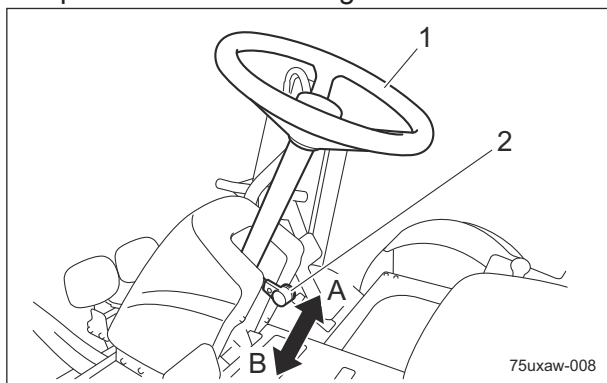

Tilt Lever_001

1	Steering wheel
2	Tilt lever
A	FREE (released)
B	LOCK (locked)

Traveling Pedal

The traveling pedal controls forward and backward operation of the machine.

1. Depress the forward pedal (front side) to travel the machine forward.
2. Depress the backward pedal (rear side) to travel the machine backward.

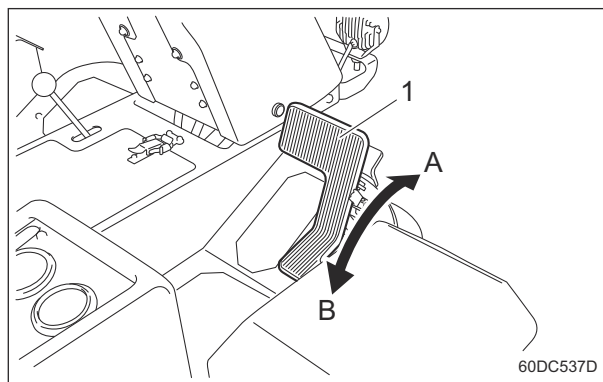

Traveling Pedal_001

1	Traveling pedal
A	Forward
B	Backward

Pedal Stopper

Pedal stopper changes the amount of "Forward" side of traveling pedal can be depressed. Be sure to set the pedal stopper to the "Working" position during operation.

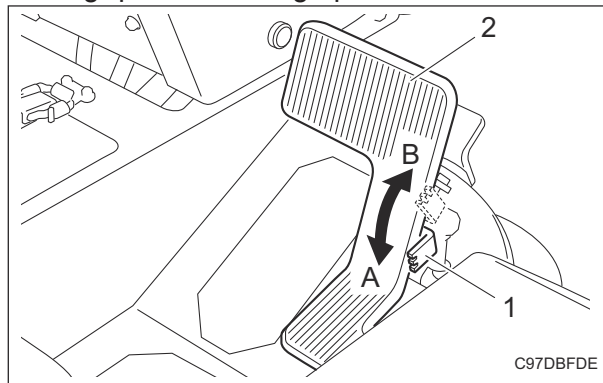

Pedal Stopper_001

1	Pedal stopper
2	Traveling pedal
A	Working
B	Traveling

Description of Functions

Brake Pedal

The brake pedal is used for stopping the machine.

To stop the machine, depress the brake pedal firmly.

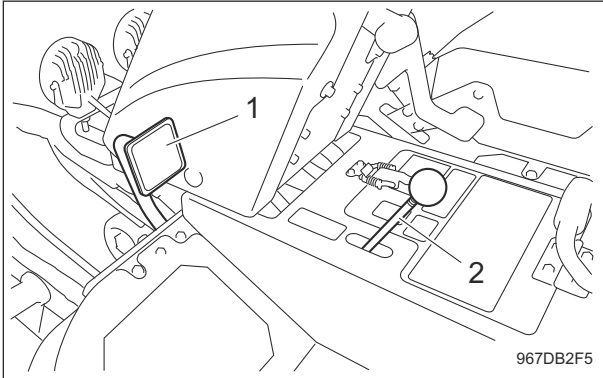

Brake Pedal_001

1	Brake pedal
2	Parking brake lever

Parking Brake Lever

⚠ Caution

Do not park the machine on a slope.

Important

Be sure to release the parking brake before driving. Otherwise, the brakes or hydraulic system will malfunction.

The brake must be applied to lock the brake pedal with the parking brake lever.

1. Applying the parking brake:

- [1] Depress the brake pedal firmly, and pull up the parking brake lever to the top.
- [2] Make sure the brake pedal is locked, and then take your foot off the pedal.

2. Releasing the parking brake:

Depress the brake pedal again, and release the lock of the brake pedal.

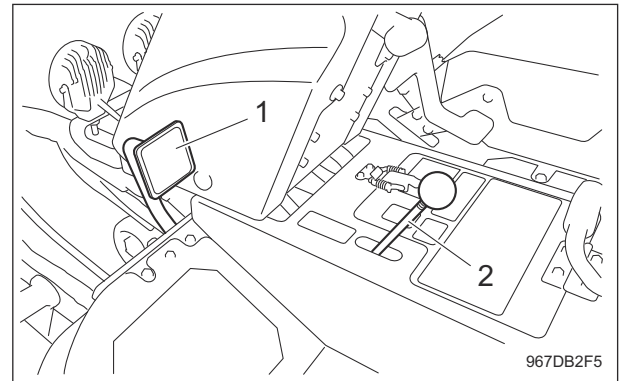

Parking Brake Lever_001

1	Brake pedal
2	Parking brake lever

Reel Rotation/Stop Switching Lever

⚠ Caution

Before operating the reel rotation/stop switching lever, be sure to set the reel rotation switch to the "Stop" position.

The reel rotation/stop switching lever is located on the reel motor attached to each mower unit. It is used during cutting and back lapping. Shift the lever(s) to the "Rotation" position only for the mower unit(s) to be used for cutting or back lapping. Leave the lever(s) for other mower units in the "Stop" position.

■ #10001 - 10163, #10170 - 10175

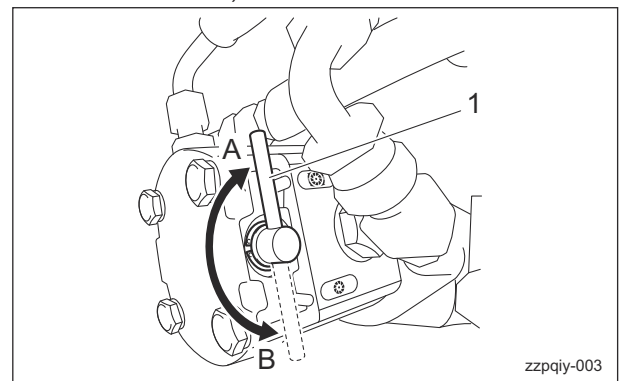

Reel Rotation/Stop Switching Lever_001

1	Reel rotation/stop switching lever
A	Rotation
B	Stop

Description of Functions

■ #10164 - 10169, #10176-

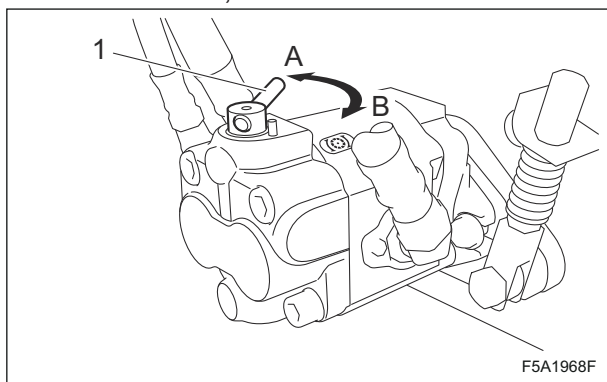

Reel Rotation/Stop Switching Lever_002

1	Reel rotation/stop switching lever
A	Stop
B	Rotation

Instruments on the Operation Panel

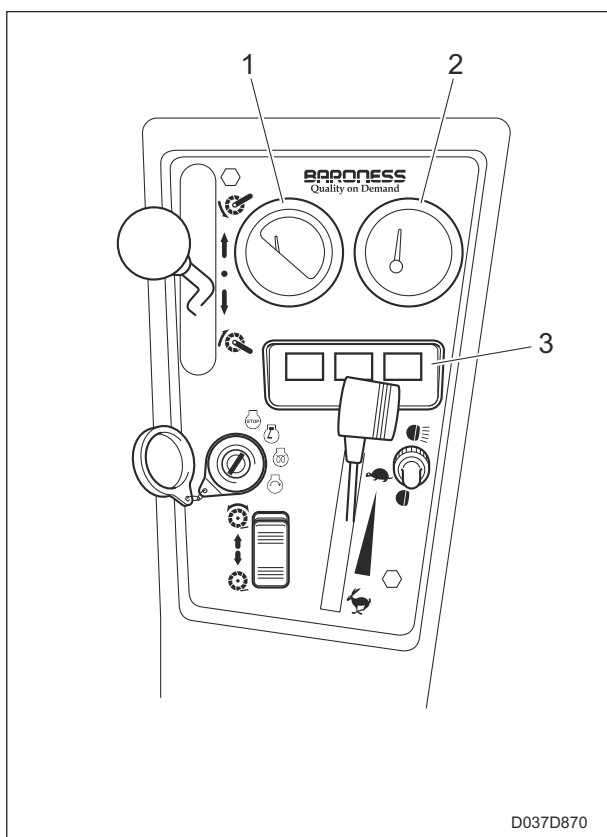

Instruments on the Operation Panel_001

1	Water temperature gauge
2	Fuel gauge
3	Pilot lamps (charge lamp, thermo-start lamp, oil pressure lamp)

Water Temperature Gauge

This instrument indicates the water temperature inside the engine. If the water temperature gauge indicates a level close to "H" during operation, the machine is overheated. Remove the load from the engine, idle the machine for five minutes, stop the engine, and then inspect the machine and perform any necessary maintenance.

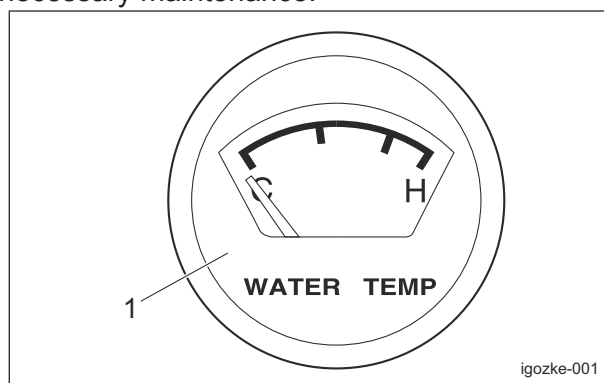

Water Temperature Gauge_001

1	Water temperature gauge
---	-------------------------

Fuel Gauge

The fuel gauge is located in the operation panel. This instrument indicates the quantity of fuel inside the fuel tank.

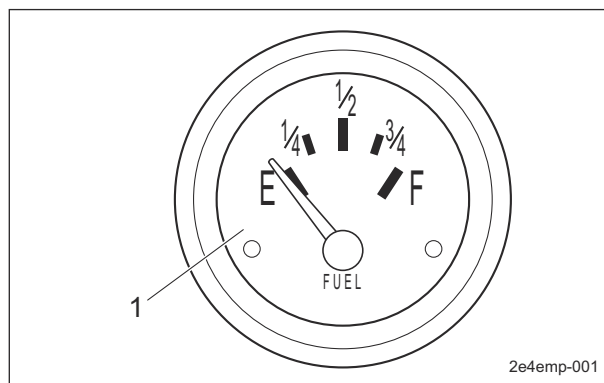

Fuel Gauge_001

1	Fuel gauge
---	------------

Description of Functions

Pilot Lamps

Charge Lamp

The charge lamp is the left pilot lamp located in the operation panel.

It turns on when the ignition key is set to the "ON" position before the engine starts. It turns off when the engine starts and the alternator starts operating properly.

If this lamp illuminates while you are operating the machine, stop the engine immediately, and then inspect the machine and perform any necessary maintenance.

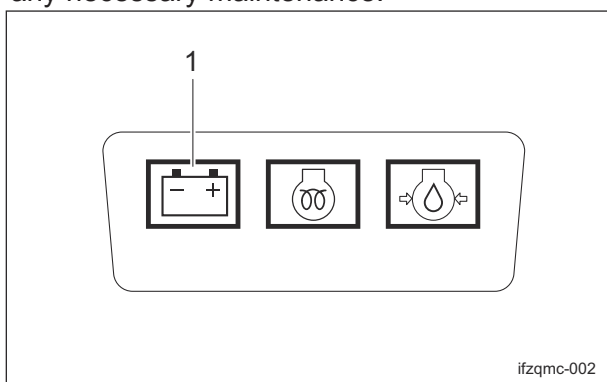

Charge Lamp_001

1	Charge lamp
---	-------------

Oil Pressure Lamp

The oil pressure lamp is the right pilot lamp located in the operation panel.

It turns on when the ignition key is set to the "ON" position before the engine starts. It turns off when the engine starts and engine oil pressure is generated properly.

If this lamp illuminates while you are operating the machine, stop the engine immediately, and then inspect the machine and perform any necessary maintenance.

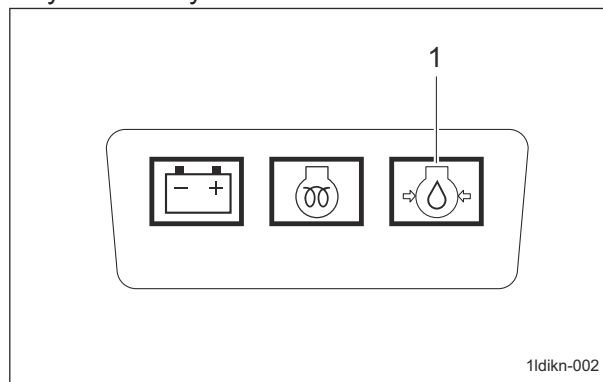

Oil Pressure Lamp_001

1	Oil pressure lamp
---	-------------------

Thermo-Start Lamp

The thermo-start lamp is the middle pilot lamp located in the operation panel.

When the ignition key is set to the "GLOW" position, it illuminates as the glow plug generates heat.

Illumination of the thermo-start lamp is controlled by the glow lamp timer, and the lamp is turned off after a specified amount of time passes.

The duration of illumination indicates an approximate period of time required for warm-up, and has been fixed at five seconds.

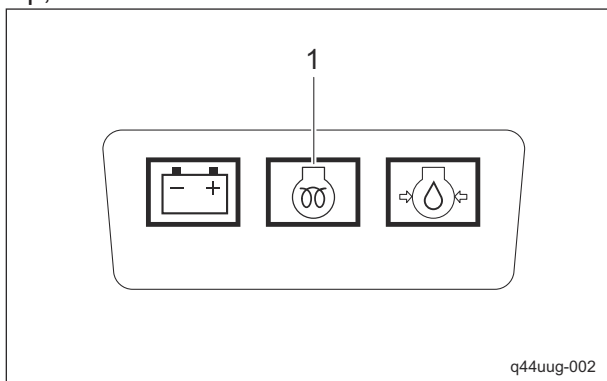

Thermo-Start Lamp_001

Description of Functions

Hour Meter

The hour meter indicates the accumulated operation time of the engine.

The number in red figures on a white background is incremented every thirty-six seconds.

The number in white figures on a black background is incremented every hour.

1/100 wheel ... red figures on a white background

Hour wheel ... white figures on a black background

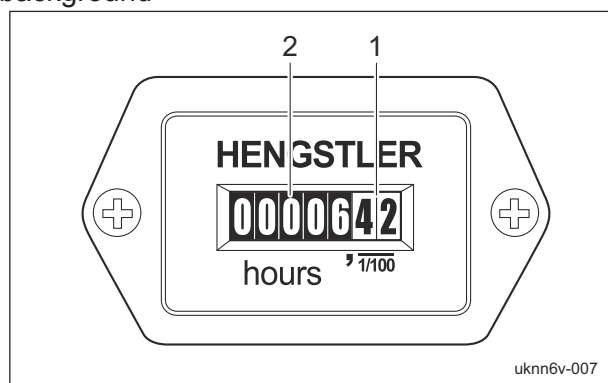

Hour Meter_001

1	1/100 wheel
2	Hour wheel

Safety Device

Interlock System

This machine features an interlock system for starting and stopping the engine.

- As for starting the engine, the safety device prevents the engine from starting unless it meets each of the following four conditions.
 - An operator is sitting on the seat.
 - The parking brake is applied.
 - The reel rotation switch is set to the "OFF" position.
 - The traveling pedal is set to the neutral position.
- In the event the operator leaves the seat with the parking brake not applied and the engine running, the safety device will be activated and will stop the engine.

- In the event the operator leaves the seat with the parking brake applied and the engine running, the safety device will be activated and will stop the engine under any of the following conditions:
 - The traveling pedal is not set to the neutral position. (The operator has depressed the traveling pedal.)
 - The reel rotation switch is set to the "Rotate" position. However, when the reel forward/reverse switch is set to the "ON" position (reverse rotation), the engine does not stop.

Warning Mechanisms

Warning Buzzer

- Overheat Warning Buzzer**
When the water temperature inside the engine exceeds 105 °C (221 °F), the buzzer sounds. (intermittent tone)
If the water temperature gauge indicates a level above the "H" when the buzzer sounds, the engine is overheated.
5 minutes after idling the engine with no load, stop the engine and inspect the machine and perform any necessary maintenance.
- Hydraulic Oil Level Warning Buzzer**
When the oil level in the hydraulic tank decreases from the specified level by approximately 2.8 dm³ (2.8 L), the buzzer sounds. (intermittent tone)
If the water temperature gauge indicates a level below the "H" when the buzzer sounds, hydraulic oil level has decreased.
Stop the engine immediately, and then inspect the machine and perform any necessary maintenance.

Description of Functions

Operations before Service Page 5-2

Procedure to Open/Close Hood Page 5-2

Procedure to Open/Close Radiator
Cover Page 5-2

Procedure to Open/Close Underseat
Cover Page 5-3

Procedure to Open/Close Center
Cover Page 5-3

Inspection before Use Page 5-4

EnginePage 5-4

Main Vehicle Page 5-7

Adjustment before Work Page 5-10

Main Vehicle Page 5-10

Mounting and Dismounting Page 5-11

Procedure to Mount/Dismount Page 5-11

Start/Stop of Engine Page 5-11

Procedure to Start EnginePage 5-11

Procedure to Stop Engine Page 5-13

Parking and StoppingPage 5-13

Procedure to Leave The Machine Page 5-13

MovePage 5-13

Traveling Procedure Page 5-13

Cutting Work Page 5-14

Cutting ProcedurePage 5-14

Procedure to Remove/Install Grass
Catcher Page 5-14

TransportingPage 5-15

Transporting Procedure Page 5-15

Cleaning after Use Page 5-16

EnginePage 5-16

Main Vehicle Page 5-17

Storage Page 5-17

Short-Term Storage Page 5-17

Handling Instructions

Operations before Service

The following sections describe the preparatory works required before performing the services including inspection, adjustment, cleaning, maintenance and repair.

Procedure to Open/Close Hood

Caution

Do not open the hood in strong winds.

Caution

Be careful not to pinch your fingers when you open or close the hood.

1. Procedure to open the hood:

- [1] Remove the snap pin, then the washer.
- [2] Remove the bolt.

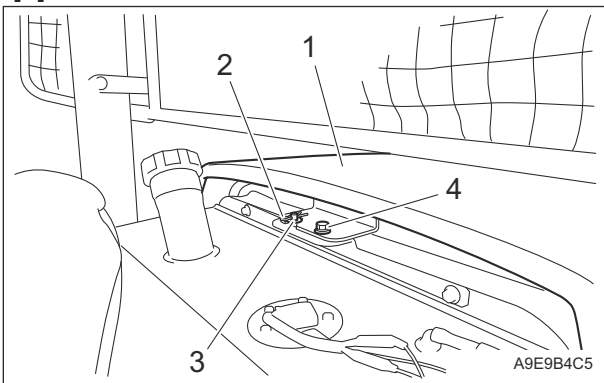

Procedure to Open/Close Hood_001

1	Hood
2	Snap pin
3	Washer
4	Bolt

- [3] Lift up the hood.
- [4] Make sure that the hood will not close, and then remove your hands.

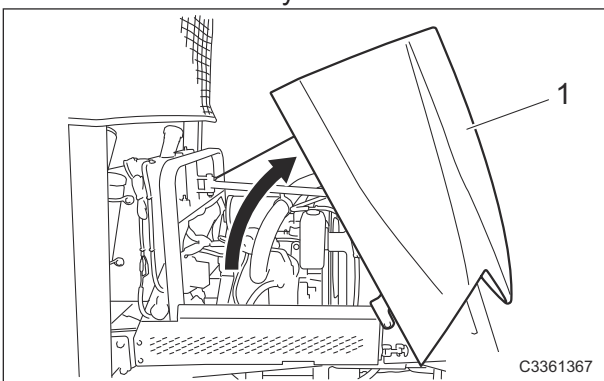

Procedure to Open/Close Hood_002

1	Hood
---	------

2. Procedure to close the hood:

- [1] Close the hood slowly.
- [2] Press the hood lightly and lock it with the bolt.
- [3] Install the washer, and inset the snap pin.

Procedure to Open/Close Radiator Cover

Caution

Do not open the radiator cover in strong winds.

Caution

Be careful not to pinch your fingers when you open or close the cover.

1. Procedure to open the radiator cover:

- [1] Unlock the rubber catch on the left and right side.
- [2] Hold the left and right handle and pull the radiator cover.

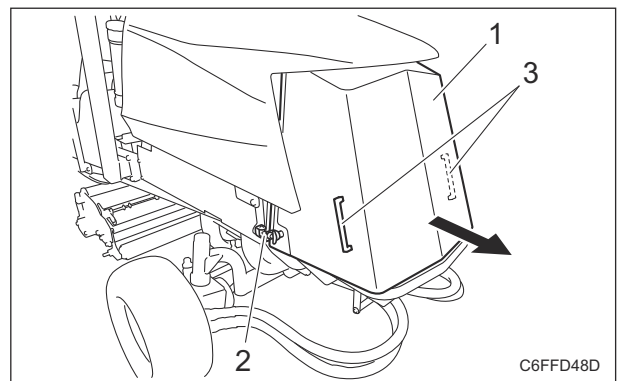

Procedure to Open/Close Radiator Cover_001

1	Radiator cover
2	Rubber catch
3	Handle

Handling Instructions

[3] Pull the radiator cover to the back to open it.

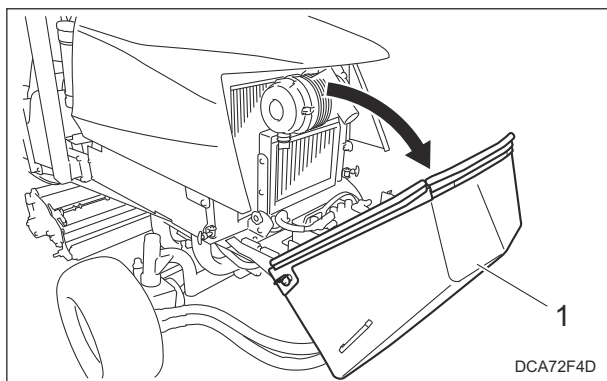

Procedure to Open/Close Radiator Cover_002

1	Radiator cover
---	----------------

2. Procedure to close the radiator cover:

[1] Close the radiator cover slowly.

[2] Lock the rubber catch on the right and left side securely.

Procedure to Open/Close Underseat Cover

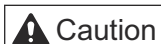

Caution

Be careful not to pinch your fingers when you open or close the underseat cover.

1. Opening procedure

[1] Bring the seat to the most front position.

[2] Remove two bolts located on the rear of the seat.

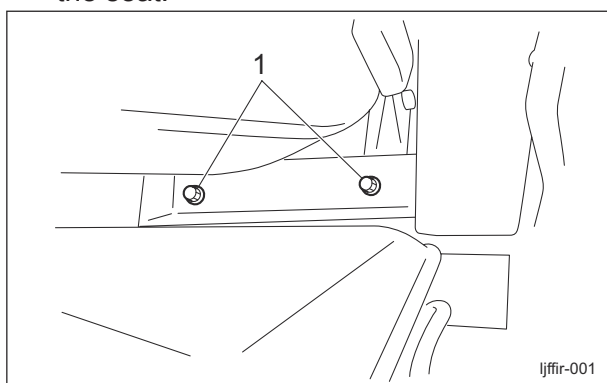

Procedure to Open/Close Underseat Cover_001

1	Bolt
---	------

[3] Bring the seat to the backmost position.

[4] Lift the seat.

[5] Securely support the underseat cover with the seat support rod.

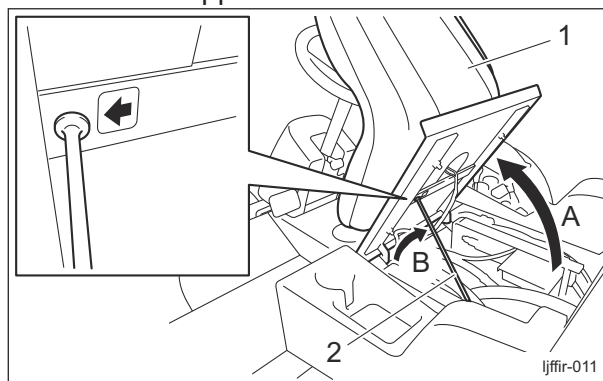

Procedure to Open/Close Underseat Cover_002

1	Seat
2	Seat support rod
A	Step 1
B	Step 2

2. Closing procedure

[1] Remove the seat support rod with the seat held with a hand.

[2] Lower the seat slowly to close the underseat cover.

[3] Bring the seat to the frontmost position.

[4] Install two bolts on the rear of the seat.

Procedure to Open/Close Center Cover

1. Procedure to open the center cover:

[1] Release the catch clip.

[2] Open the center cover.

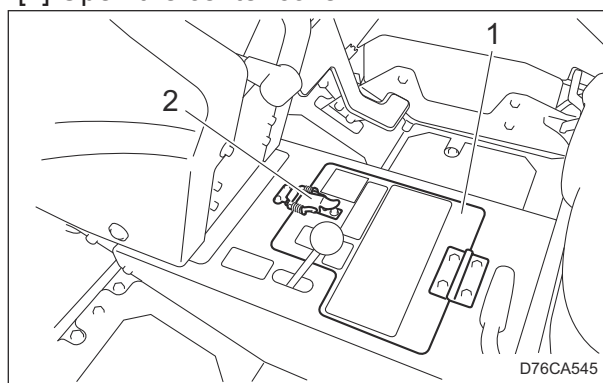

Procedure to Open/Close Center Cover_001

1	Center cover
2	Catch clip

2. Procedure to close the center cover:

[1] Close the center cover.

[2] Fasten the catch clip securely.

Handling Instructions

Inspection before Use

The purpose of the machine inspection is to:

- Prevent accidents
- Prevent damage to the machine
- Maintain machine performance

Detecting machine malfunctions early helps prevent unexpected problems from occurring. If you detect any abnormalities with the machine, immediately perform maintenance or repairs.

Engine

Inspection of Engine Oil

Important

Securely insert the oil level gauge.

Check the contamination of oil and engine oil level to inspect the engine oil.

Inspect the engine oil level 10 to 20 minutes after stopping the engine.

1. Place the machine so that the engine is level.
2. Stop the engine.
3. Open the hood.
4. Pull out the oil level gauge.

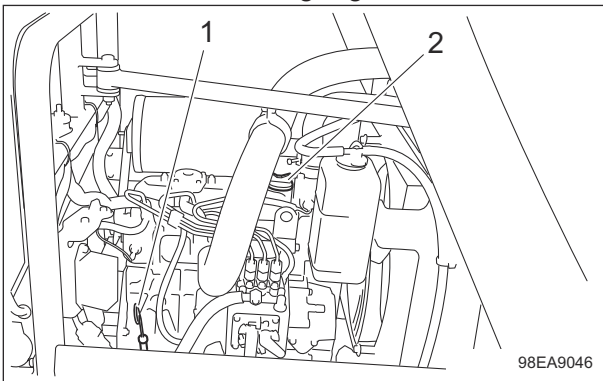

Inspection of Engine Oil_001

1	Oil level gauge
2	Oil filler cap

5. Wipe the oil off the oil level gauge cleanly with papers or cloths.
6. After wiping the oil off the oil level gauge, check the remains of contamination.
7. Return the oil level gauge to its original position, insert tightly, and pull out again.

8. Check the engine oil level.

The appropriate oil level should be between the upper and lower limit lines on the gauge.

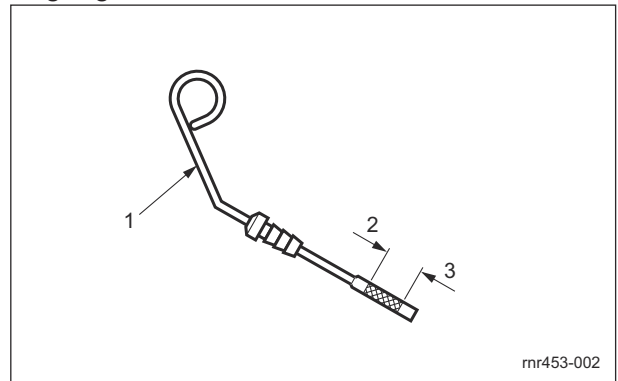

Inspection of Engine Oil_002

1	Oil level gauge
2	Upper limit
3	Lower limit

9. Return the oil level gauge to its original position, and insert it tightly.

10. Close the hood.

Inspection of Fuel Quantity

With the machine on a level surface, observe the fuel gauge in the operation panel to check the fuel level.

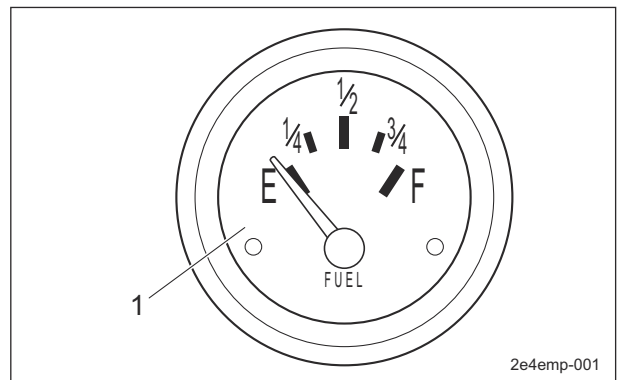

Inspection of Fuel Quantity_001

1	Fuel gauge
---	------------

Handling Instructions

Supply of Fuel

Warning

Do not supply fuel above the middle (marked in red) of the fuel gauge.
If you supply too much fuel, it might overflow from the fuel cap when you travel or work on a slope.

Warning

Keep fire away while refueling.
Do not smoke while refueling.

If the fuel gauge located in the operation panel indicates the level close to E (EMPTY), supply fuel (diesel) as soon as possible. Refuel up to the middle (marked in red) of the fuel gauge.
The fuel tank capacity is approximately 38.0 dm³ (38.0 L).

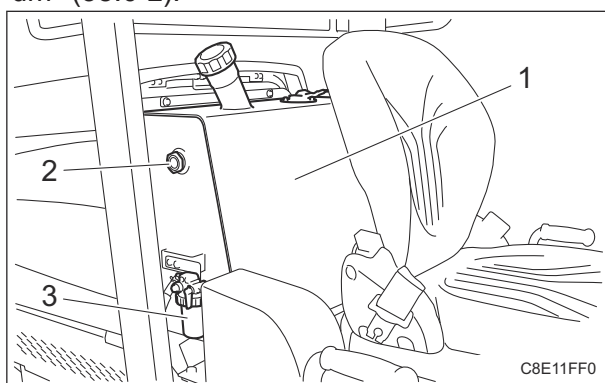

Supply of Fuel_001

1	Fuel tank
2	Fuel gauge
3	Fuel strainer

Air Bleeding of Fuel System

Important

Be sure to tighten the air-bleeding plug except when air bleeding.
Otherwise, it may cause the engine stop.

This machine has a function of automatic air bleeding.
However, depending on the mechanical structure, it may not bleed air completely.
If the automatic air bleeding does not work well, follow the steps below to perform manual air bleeding.

1. Fill up the fuel tank with fuel and open the fuel cock.
2. Loosen the air-bleeding plug of the fuel filter 2 to 3 turns.
3. If air bubble of the fuel from the plug has gone, tighten the plug.

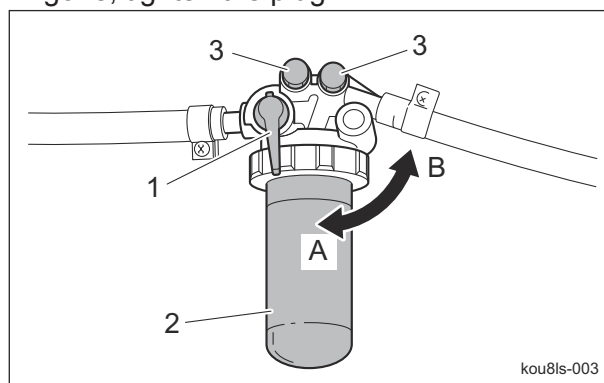

Air Bleeding of Fuel System_001

1	Fuel cock
2	Fuel filter
3	Air-bleeding plug
A	ON (Open)
B	OFF (Close)

4. Loosen the air-bleeding plug of the injection pump.

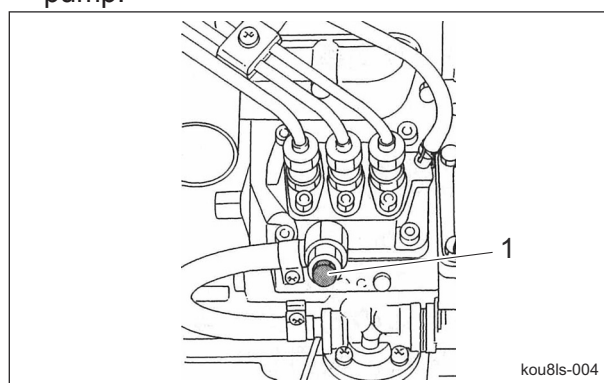

Air Bleeding of Fuel System_002

1	Air-bleeding plug
---	-------------------

5. Sit on the operator's seat.
6. Make sure that the parking brake is applied.
7. Set the reel rotation switch to the "STOP" position.
8. Make sure that the traveling pedal is in the neutral position.
9. Set the ignition key to the "START" position.

Handling Instructions

Important

In the case that there are still air bubbles in the fuel from air-bleeding plug even after 15 seconds or more passed after setting the ignition key to "START", pause for 30 seconds or more and then repeat the same procedure.

10. If the starter rotates and air bubble of the fuel from the air-bleeding plug has gone, return the ignition key slowly to "OFF" position and tighten the plug.

Inspection of Fuel Filter

1. Make sure that there is no fuel leakage.
2. Make sure that the filter is not damaged.
3. Make sure that the filter is not contaminated.

Inspection of Coolant

Caution

Do not touch the radiator or coolant during engine operation or right after the engine has been turned off. Otherwise, you may get burned due to high temperatures.

Caution

Inspection should take place after the engine has well cooled down.

Make sure that the coolant level in the reserve tank is between "FULL" and "LOW." When the coolant level is lower than the "LOW" mark, fill the tank with clean water and antifreeze.

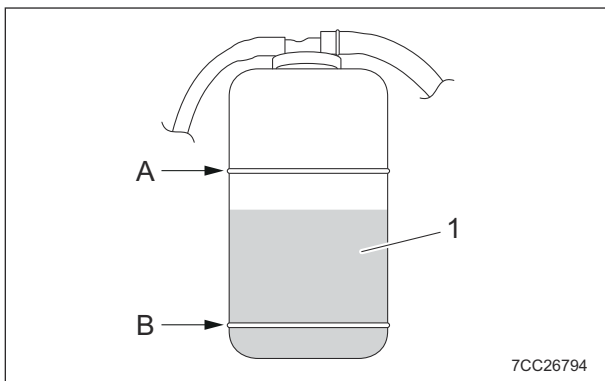

Inspection of Coolant_001

1	Reserve tank
2	FULL
3	LOW

Inspection of Engine-Associated Parts

Caution

Perform operations after the muffler, engine and other parts have sufficiently cooled. Otherwise, you may get burned.

1. Check for damages and dirt.
2. Check the mount for looseness and cracks.
3. Check for liquid leakage.
4. Check on and around the muffler for grass clippings and flammable materials.

Inspection of Air Cleaner

1. Make sure that there is no damage to the air cleaner.
2. Make sure that the air cleaner filter is not contaminated.

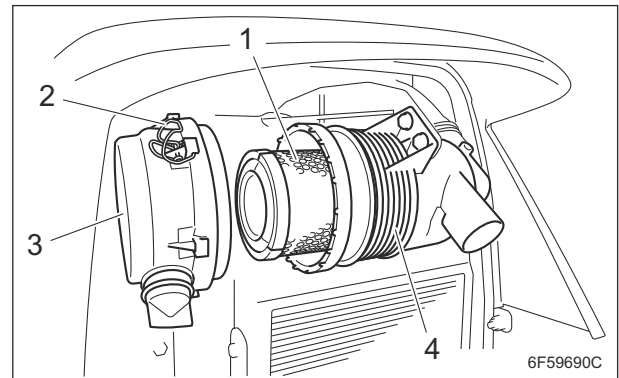

Inspection of Air Cleaner_001

1	Air cleaner filter
2	Clip
3	Air cleaner cap
4	Air cleaner body

Inspection of Radiator Cover

1. Make sure that there is no damage to the radiator cover.
2. Make sure that the radiator cover is not contaminated.

Inspection of Radiator

1. Make sure that there is no damage to the radiator.
2. Make sure that the radiator is not contaminated.

Handling Instructions

Main Vehicle

Inspection of Oil Cooler

1. Make sure that there is no damage to the oil cooler.
2. Make sure that the oil cooler is not contaminated.

Inspection of Battery

⚠ Danger

Keep away from fire while inspecting or charging the battery.
The battery may explode.

⚠ Caution

Implement after the engine and muffler etc. have well cooled down.
Otherwise, you may get burned.

Important

Be sure to stop the engine before inspecting or charging the battery.

Battery inspection items are described below.

1. Inspecting the exterior
Visually inspect the exterior of the battery, and check that there are no cracks, splits, missing sections, or abnormal deformation in the battery case, and that there is no electrolyte leaking.
If abnormalities are found, immediately replace the battery.

2. Cleaning the exterior

⚠ Warning

Do not clean the battery with a dry cloth. Cleaning the battery with a dry cloth may cause it to catch fire or explode due to static electricity.

Use a wet cloth for cleaning.
Inspect the vent plugs or vent holes on the side of the battery, and if they are blocked by dirt wash them with water to remove the blockage.
Continuing to use the battery with the vent holes blocked may cause the battery to rupture from increased internal pressure due to gases generated inside the battery.

3. Inspecting the mounting bracket
Inspect whether the battery is secured firmly with the mounting bracket.
If the bracket is loose, tighten the mounting bracket nuts until the battery is secured firmly.
An improperly mounted battery may cause damage to the battery case or electrolyte leaks due to the battery moving with vibrations while traveling.
4. Inspecting the cable terminals
If the connection between the battery terminals and vehicle's cable terminals are loose, tighten the nuts until the cable terminals are secured firmly.
Insufficiently tightened terminals may result in poor battery charging, damage to the terminals due to poor contacts, or an explosion.
If the terminals are corroded, rub them clean with a wire brush or fine grit sandpaper, and lightly apply anti-rust grease.
5. Inspecting the electrolyte level and refilling

⚠ Warning

Do not allow the battery fluid level to become lower than the LOWER LEVEL (minimum fluid level line).
The battery may explode if it is used or charged while the battery fluid level is at the LOWER LEVEL (minimum fluid level line).

⚠ Warning

When refilling, do not fill purified water above the UPPER LEVEL line.
Doing so may result in electrolyte leaks.

Clean the areas around the battery fluid level lines using a cloth dampened with water to check the electrolyte level from the side of the battery.
Make sure that the battery fluid level is between the UPPER LEVEL (maximum fluid level line) and the LOWER LEVEL (minimum fluid level line).
Refill with purified water up to the UPPER LEVEL line if the level is lower than halfway between the UPPER LEVEL and LOWER LEVEL lines.

Handling Instructions

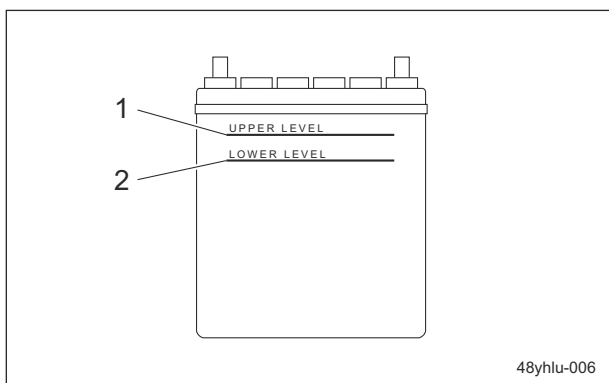

Inspection of Battery_001

1	UPPER LEVEL line
2	LOWER LEVEL line

Inspection of Hydraulic Oil

The oil gauge is on the side of the hydraulic tank.

1. Lower the mower units and maintain that position on a level surface.
2. Make sure that the oil level is at the middle of the oil gauge.

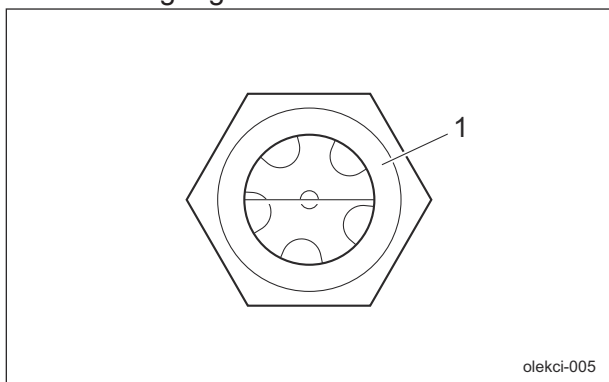

Inspection of Hydraulic Oil_001

1	Oil gauge
---	-----------

3. Check underneath the machine for oil leakage.

Inspection of Tires

1. Make sure that there are no cracks, damage or abnormal wear.
2. Check the pneumatic pressure of the tires.

	Tire size	Pneumatic pressure	
Front wheel	23 x 10.50 - 12	120 kPa (1.2 kgf/cm ²)	17 psi
Rear wheel	18 x 8.50 - 10	120 kPa (1.2 kgf/cm ²)	17 psi

Inspection of Covers

Warning

If you have removed the cover during inspection, make sure that you replace it in the original position securely. If the cover remains removed, the operator or the mechanic may come in contact with the rotating objects or belt, or foreign objects may fly off, possibly resulting in injuries.

1. Make sure that there is no wear or deterioration of covers.
2. Make sure that there is no damage to covers.
3. Make sure that there is no interference with moving parts due to deformation of covers.
4. Make sure that covers are installed in their appropriate positions.

Inspection of Wire

1. Make sure that the wire is not cracked or damaged.
2. Make sure that the wire is not worn.
3. Make sure that the wire is not crushed.
4. Make sure that the wire is not bent.
5. Make sure that the wire is not corroded or rusted.

Inspection of Brake Pedal

1. Make sure that there is no play in the pedal.
2. Make sure that the pedal moves smoothly.
3. Make sure that there is no abnormal sound when the pedal is depressed.
4. Make sure that the pedal does not touch the floorboard when the pedal is depressed.

Inspection of Parking Brake Lever

1. Make sure that the brake pedal is locked after depressing the brake pedal completely and pulling the parking brake lever completely.
2. Make sure that the brake pedal is released after depressing the brake pedal again.

Handling Instructions

Inspection of Traveling Pedal

1. Make sure that there is no play in the pedal.
2. Make sure that the pedal moves smoothly.
3. Make sure that there is no abnormal sound when the pedal is depressed.

Inspection of Pedal Stopper

1. Make sure that the pedal stopper fulcrum does not rattle.
2. Make sure that the stopper bolt is tightened with fixing nut.
3. When the pedal stopper is used, make sure that the pedal stopper touches the floorboard when the pedal is depressed.

Inspection of Liquid Leakage

Important

After approximately 50 hours of operation, some tightened portions may be loosened and liquid such as oil may leak. Be sure to retighten the parts.

Important

Repair the machine before operation if liquid leakage found. Ignoring leakage will cause further trouble.

1. Check the bottom of the machine for leakage of liquid such as oil, water, fuel, etc.
2. Locate the leakage and identify the type of liquid.

Inspection of Ball Proof Net

1. Check the ball proof net is not deteriorated.
2. Check there is no damage nor deformation of the ball proof net.

Inspection of Bolts and Nuts

Important

The bolts and nuts may be loosened at the earlier stage of the use. Be sure to retighten or replace before operating the machine whenever there is any abnormality.

1. Check the bolts and nuts for looseness and coming off.

2. Check the bolts and nuts for cracks and damages.
3. Check the bolts and nuts for rust.
4. Check around the bolts and nuts for traces of rust fluid.
5. Check for unequal bolt length.
6. Check the bolts and nuts for stripped threads and abrasion.

Inspection of Hour Meter

1. Check the hour meter is not damaged.
2. Check the hour meter operates correctly.
 - [1] Switch the ignition key to the "ON" position.
 - [2] Check the displayed number increases correctly.
 - [3] Switch the ignition key to the "OFF" position.

Inspection of Water Temperature Gauge

1. Check the water temperature is not damaged.
2. Check the water temperature operates correctly.
 - [1] Switch the ignition key to the "ON" position.
 - [2] Check the water temperature needle swings.
 - [3] Switch the ignition key to the "OFF" position.

Inspection of Fuel Gauge

1. Check the fuel gauge is not damaged.
2. Check the fuel gauge operates correctly.
 - [1] Switch the ignition key to the "ON" position.
 - [2] Check the fuel gauge needle swings.
 - [3] Switch the ignition key to the "OFF" position.

Inspection of Pilot Lamps

1. Check the pilot lamps are clean.
2. Check the pilot lamps are not damaged.

Handling Instructions

Inspection of Safety Device

Repair the machine before operation whenever there is any abnormality.

1. Interlock system
Make sure that the interlock system operates correctly.
"Interlock System" (Page 4-9)
2. ROPS
(If the machine is equipped with ROPS and a seat belt)
Make sure that the ROPS is not damaged or broken.
3. Seat belt
(If the machine is equipped with ROPS and a seat belt)
Make sure that the seat belt is not damaged or broken.

Inspection of Steering Wheel

1. Make sure that there is no play in the steering wheel.
2. Make sure that the steering wheel turns smoothly when it is turned.
3. Make sure that there is no abnormal sound when the steering wheel is turned.
4. Check the direction of tires when the steering wheel is turned.
 - [1] Start the engine.
 - [2] Make sure that the rear tire turns left when the steering wheel is turned right.
 - [3] Make sure that the rear tire turns right when the steering wheel is turned left.
 - [4] Stop the engine.

Inspection of Light

1. Check the lights are not damaged.
2. Check the lights turn on/off.
 - [1] Switch the ignition key to the "ON" position.
 - [2] Set the light switch to the "ON" position.
 - [3] Check the lights have turned on.
 - [4] Set the light switch to the "OFF" position.
 - [5] Check the lights have turned off.
 - [6] Switch the ignition key to the "OFF" position.

Adjustment before Work

Main Vehicle

Adjustment of Seat Position

Warning

Do not adjust while traveling since it is dangerous.

Adjust the position to fit the operator.

1. Use the forward/backward adjustment lever to adjust the seat back and forth.
2. Use the backrest tilt adjustment lever to adjust the angle of the backrest.
3. Pull out the suspension adjustment handle and move it up or down to adjust the firmness of the seat suspension.
Observe the suspension adjustment scale while making adjustments. [50 - 160 kg (110.2 - 352.7 lb)]

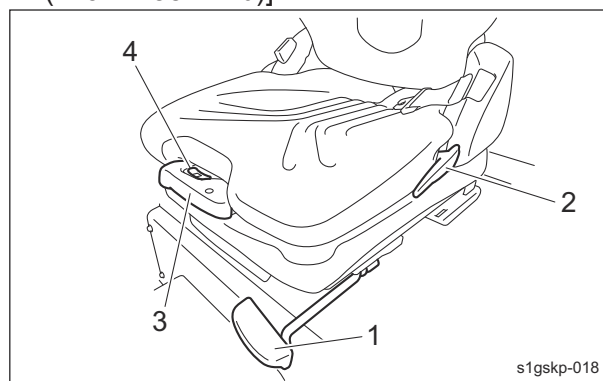

Adjustment of Seat Position_001

1	Forward/backward adjustment lever
2	Angle adjustment lever
3	Suspension adjustment handle
4	Suspension adjustment scale

Handling Instructions

Adjustment of Steering Wheel Position

Warning

Since it is dangerous, do not adjust the steering wheel while traveling.

Caution

Make sure the steering wheel position is securely locked. It may result in an unexpected accident if it becomes loose while traveling.

The steering wheel position can be adjusted up or down. Adjust the position according to the operator's body size.

1. Shift the tilt lever to the "FREE" position.
2. Adjust the steering wheel position.
3. Shift the tilt lever to the "LOCK" position and secure the steering wheel position.

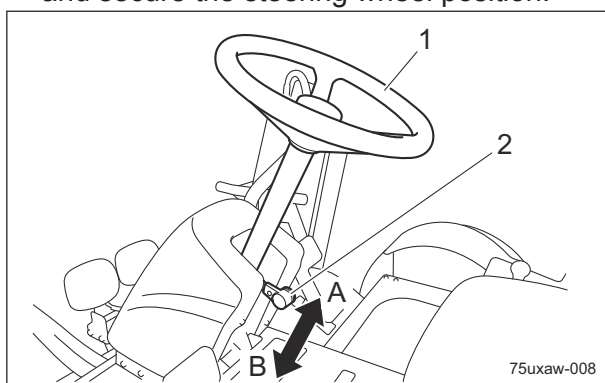

Adjustment of Steering Wheel Position_001

1	Steering wheel
2	Tilt lever
A	FREE (released)
B	LOCK (locked)

Mounting and Dismounting

Procedure to Mount/Dismount

This machine is equipped with a step for mounting/dismounting. Place your foot on the step when mounting and dismounting the machine.

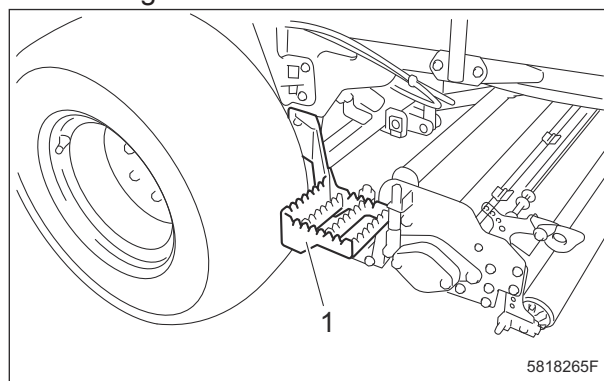

Procedure to Mount/Dismount_001

1	Step
---	------

Start/Stop of Engine

Procedure to Start Engine

Caution

Before starting the engine, make sure that there are no other people or obstacles around the machine.

Important

Starter operation must take 15 seconds or less. If the engine still does not start, stop using the battery for 30 to 60 seconds to avoid exhausting the battery.

1. Make sure that the fuel cock of the water separator is open.

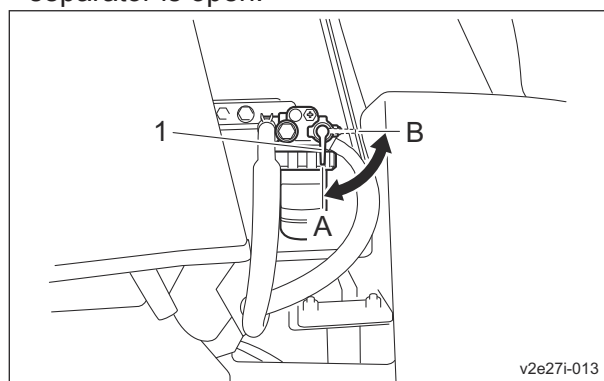

Procedure to Start Engine_001

Handling Instructions

1	Fuel cock
A	ON (Open)
B	OFF (Close)

2. Make sure that the fuel cock of the fuel filter is open.

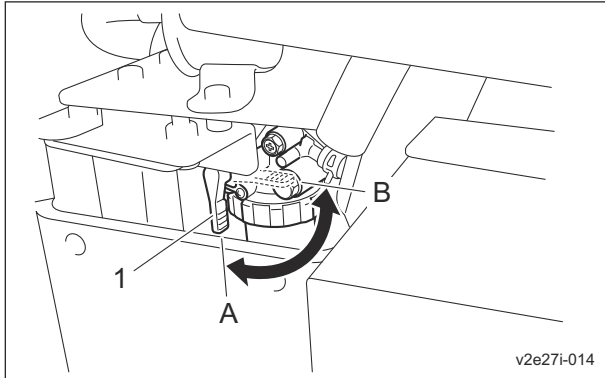

Procedure to Start Engine_002

1	Fuel cock
A	ON (Open)
B	OFF (Close)

3. Sit on the seat.
4. Depress the brake pedal and make sure that the parking brake is applied.
5. Make sure that the reel rotation switch is set to the "Stop" position.
6. Make sure that the mower unit up/down lever is set to the "Neutral" position.
7. Make sure that the traveling pedal is in the neutral position.
8. Move the throttle lever halfway from the "Low speed" position toward the "High speed" position.

Important

The thermo-start lamp turns off at the specified time. However, the lamp turning off is not related to the glow plug generating heat. If the ignition key is left in the "GLOW" position after the lamp is turned off, the plug will still generate heat. The thermo-start lamp will stay illuminated for 5 seconds.

9. Switch the ignition key to the "GLOW" position.

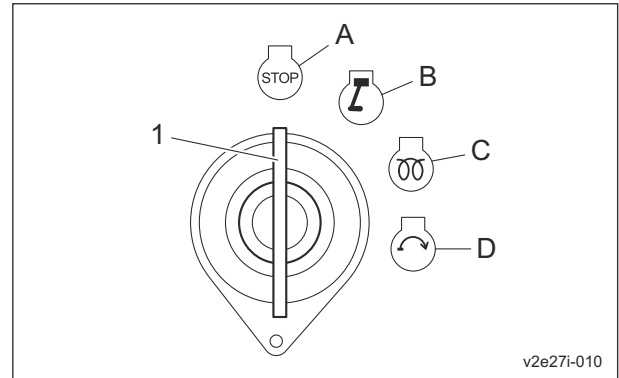

Procedure to Start Engine_003

1	Ignition key
A	OFF
B	ON
C	GLOW
D	START

10. Make sure that the thermo-start lamp is turned on.

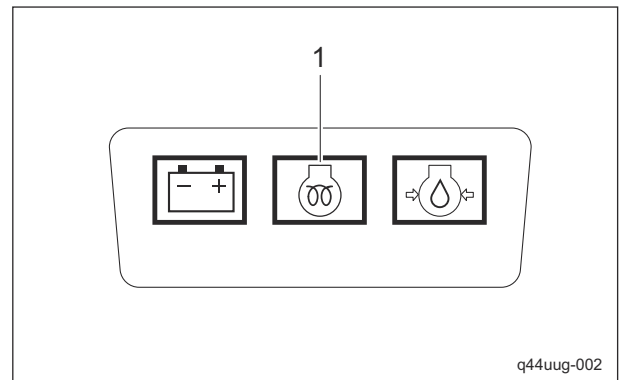

Procedure to Start Engine_004

1	Thermo-start lamp
---	-------------------

11. After the thermo-start lamp turns off, immediately set the ignition key to the "START" position.

Important

Quickly returning the ignition key from the "START" position to the "ON" position may result in damage to the machine.

12. When the starter starts rotating and the engine starts, return the ignition key to the "ON" position slowly.

Handling Instructions

13. Make sure that the charge lamp and oil pressure lamp turn off.
If they do not turn off, stop the engine and inspect the machine.

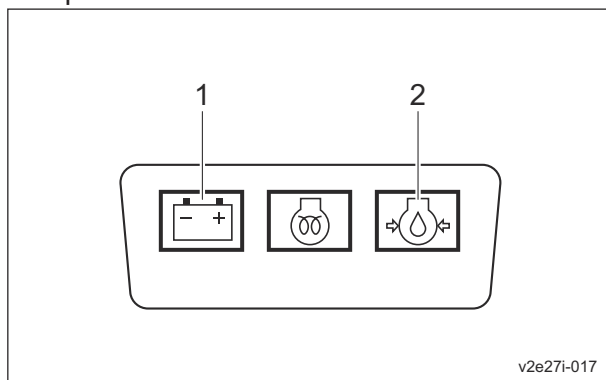

Procedure to Start Engine_005

1	Charge lamp
2	Oil pressure lamp

14. Move the throttle lever to the "Low speed" position, and then warm up the engine so that the needle points above "C" on the water temperature gauge.

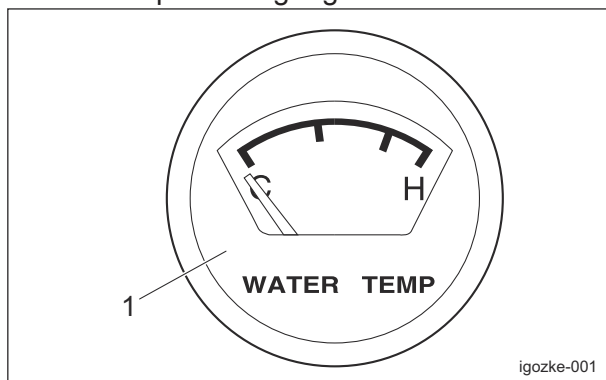

Procedure to Start Engine_006

1	Water temperature gauge
---	-------------------------

Procedure to Stop Engine

1. Set the traveling pedal to the neutral position.
2. Apply the parking brake.
3. Set the reel rotation switch to the "Stop" position.
4. Raise all the mower units.
5. Set the anti-falling stop valve to the "STOP" position.
6. Shift the throttle lever to the "Low speed" position, and then idle the machine for 1 - 2 minutes.
7. Switch the ignition key to the "OFF" position.
8. Make sure that the engine has stopped.

Parking and Stopping

Procedure to Leave The Machine

⚠ Caution

If the brakes are not sufficiently effective, use the wheel stoppers to secure the machine.

⚠ Caution

Never park the machine on a slope.

1. Park the machine on level ground.
2. Apply the parking brake.
3. Stop the engine.
4. Remove the ignition key.
5. Install the cap to the key switch.
6. Leave the driver's seat.

Move

Traveling Procedure

⚠ Caution

Under any circumstances drive the machine at such a speed that you can stop it immediately for emergencies.

Important

Do NOT start to move or stop the machine abruptly.
It will damage the hydraulic system or result in oil leakage.

1. Start the engine.
"Procedure to Start Engine" (Page 5-11)
2. Make sure that all the mower units are raised.
3. Make sure that the anti-falling stop valve is set to the "Stop" position.
4. Gradually shift the throttle lever to the "High speed" position.
5. Release the parking brake.
6. Slowly depress the traveling pedal.
7. The machine starts traveling.
8. Release the traveling pedal and depress the brake pedal to stop the machine.

Handling Instructions

Cutting Work

Cutting Procedure

⚠ Caution

Cutting work must be performed at an appropriate speed for the site and location. When cutting bumpy surfaces, keep the engine rpm steady, and slow down the cutting speed.

Important

Perform cutting work with the mower unit up/down lever shifted to the "DOWN" position. Reel rotation will be turned off when the mower unit up/down lever shifted to the "NEUTRAL" or "UP" position.

Important

Do NOT start to move or stop the machine abruptly. It will damage the hydraulic system or result in oil leakage.

1. Shift the reel rotation/stop switching levers of all mower units to the "Rotate" position.
2. Set the pedal stopper to the "Working" position.
3. Start the engine.
"Procedure to Start Engine" (Page 5-11)
4. Shift the throttle lever to the "High speed" position, and rev up the engine to MAX.
5. Release the parking brake.
6. Right before starting cutting work, set the anti-falling stop valve to the "Open" position.
7. Lower the mower units.
8. Set the reel rotation switch to the "Rotate" position to rotate the reel cutters (cutting cylinders) for all mower units.
9. Depress the traveling pedal to start cutting work.

Procedure to Remove/Install Grass Catcher

⚠ Caution

Stop the engine before removing or installing the grass catcher.

1. Set the reel rotation switch to the "Stop" position.
2. Lower the mower units.
3. Apply the parking brake.
4. Stop the engine.
5. Remove or install the grass catcher.

Removal of grass catcher:

Lift up the grass catcher, and remove the mounting pins on the left and right of the grass catcher from the grass catcher mounting brackets.

Installation of grass catcher:

Install the mounting pins on the left and right sides of the grass catcher into the grass catcher mounting brackets.

Mower unit #1

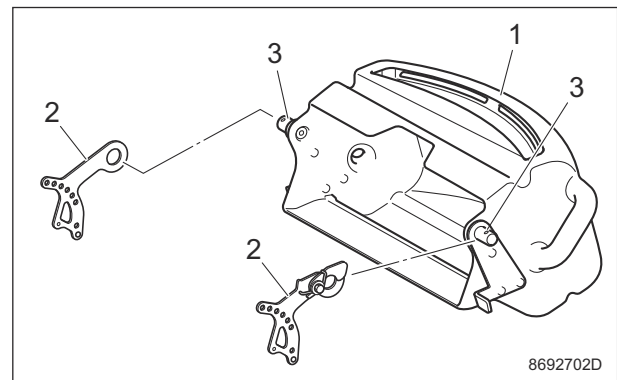

Procedure to Remove/Install Grass Catcher_001

1	Grass catcher
2	Grass catcher mounting bracket
3	Mounting pin

Mower units #2 & 3

Note :

The illustration shows the mower unit #3. Left and right positions of the grass catcher mounting brackets differ according to the location of a mower unit.

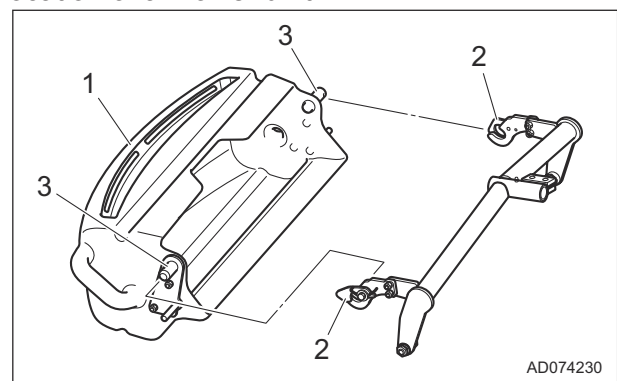

Procedure to Remove/Install Grass Catcher_002

Handling Instructions

1	Grass catcher
2	Grass catcher mounting bracket
3	Mounting pin

Transporting

Transporting Procedure

Important

If the roof is installed on the machine, remove it.
Otherwise, the roof may be damaged by wind pressure.

Important

Be sure to use cables strong enough to secure the machine.

When loading the machine onto a truck or a trailer for transport, follow the steps below.

1. Loading the machine

- [1] Remove the roof. (If the roof is installed on the machine)
- [2] Start the engine.
- [3] Travel slowly to load the machine onto a truck or a trailer.
- [4] Stop the engine.
- [5] Raise all the mower units.
- [6] Fasten the machine with ropes.

For fastening the machine with ropes, use the following positions.

- Front part of the machine: Use tow hooks on the right and left side of the frame.
- Left side

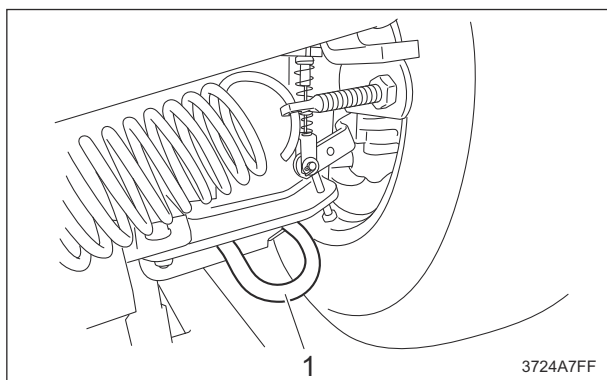

Transporting Procedure_001

1	Tow hook
---	----------

Right side

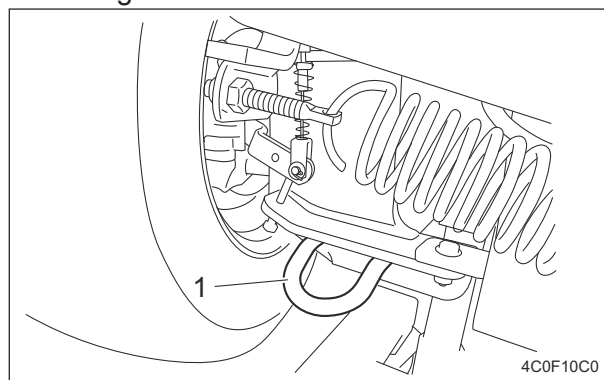

Transporting Procedure_002

1	Tow hook
---	----------

- Rear part of the machine: Use tow hooks on the right and left side of the frame.

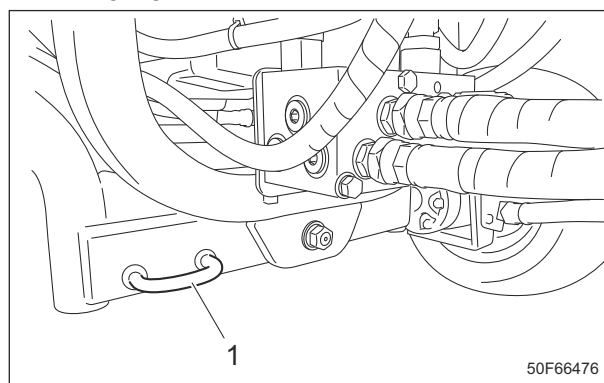

Transporting Procedure_003

1	Tow hook
---	----------

2. Unloading the machine

- [1] Remove the ropes fastening the machine.
- [2] Start the engine.
- [3] Raise all the mower units.
- [4] Travel slowly to unload the machine from the truck or trailer.

Handling Instructions

Cleaning after Use

The purpose of the machine cleaning is to:

- Prevent accidents
- Prevent damage to the machine
- Maintain machine performance

Properly clean the machine to maintain its functionality and performance.

If you detect any abnormalities with the machine, immediately perform maintenance or repairs.

Engine

Cleaning of Engine-Associated Parts

Caution

Perform operations after the muffler, engine and other parts have sufficiently cooled. Otherwise, you may get burned.

1. Clean clippings and remove dirt.
2. Blow compressed air to clean any grass or flammable materials that may be attached on or around the muffler.

Cleaning of Radiator Cover

Important

An unclean radiator cover may cause overheating to the engine. It may also cause malfunction of the hydraulic system.

If the radiator cover has been contaminated with dust, be sure to clean it. Especially after operating the machine in a dusty environment, it is important to remove dust as soon as possible.

1. Open the radiator cover.

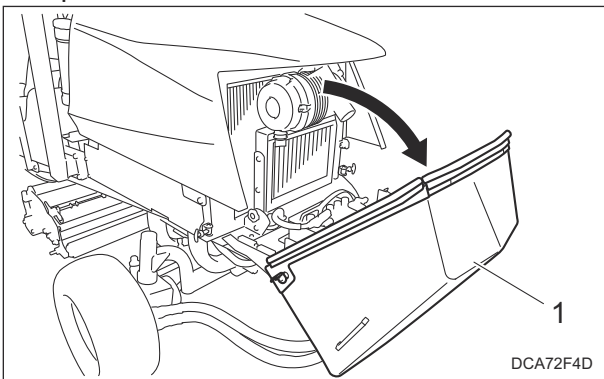

Cleaning of Radiator Cover_001

1	Radiator cover
---	----------------

2. Carefully clean the front and back of the radiator cover with water or compressed air.

Cleaning of Radiator

Caution

Do not touch the radiator or coolant during engine operation or immediately after the engine has been turned off. Otherwise, you may get burned.

Important

An unclean radiator may cause overheating to the engine. It may also cause malfunction of the hydraulic system.

Important

Do not use solid objects, such as a spatula or screwdriver, or high-pressure water to clean the radiator or oil cooler. Otherwise, special fins or tubes may be damaged, possibly resulting in reduced cooling performance or coolant/hydraulic oil leakage.

If the radiator has been contaminated with dust, be sure to clean it. After operating the machine in a dusty environment, it is important to remove dust as soon as possible.

1. Open the radiator cover.
2. Loosen the knobs on the left and right of the oil cooler, and then tilt the oil cooler.

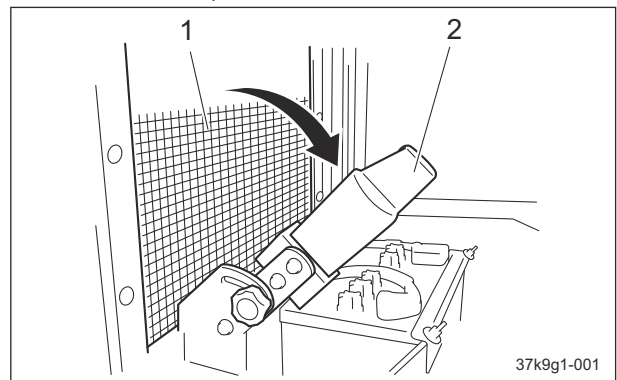

Cleaning of Radiator_001

1	Radiator
2	Oil cooler

Handling Instructions

- Carefully clean the front and back of the radiator with water or compressed air.

Main Vehicle

Cleaning of Oil Cooler

⚠ Caution

Clean after the hydraulic system has sufficiently cooled.
Otherwise, you may get burned.

⚠ Caution

An unclean oil cooler may cause malfunction of the hydraulic system.

Important

Do not use solid objects, such as a spatula or screwdriver, or high-pressure water to clean the radiator or oil cooler.
Otherwise, special fins or tubes may be damaged, possibly resulting in reduced cooling performance or coolant/hydraulic oil leakage.

If the oil cooler has been contaminated with dust, be sure to clean it.
After operating the machine in a dusty environment, it is important to remove dust as soon as possible.

- Open the radiator cover.
- Loosen the knobs on the left and right of the oil cooler, and then tilt the oil cooler.

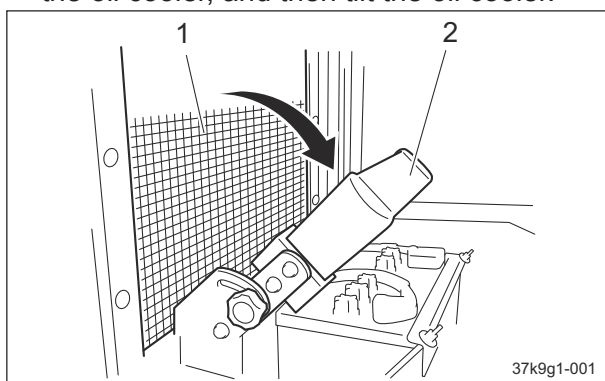

Cleaning of Oil Cooler_001

1	Radiator
2	Oil cooler

- Carefully clean the front and back of the oil cooler with water or compressed air.

Storage

Short-Term Storage

Short-term storage means that the machine is temporarily stored (within 1 month) without use.

Follow the instructions below for short-term storage of the machine.

- Cleaning
 - Remove dirt, grass clippings, oil stains etc. completely from the main vehicle and engine.
- Mower units
 - When storing this machine, lower all the mower units unless a positive mechanical lock is provided.
- Storage location
 - Cover the machine and store it in a dry place where it will not be exposed to rain.

Handling Instructions

Precautions for Maintenance	Page 6-2
Jacking Up The Machine	Page 6-2
About Jacking Up The Machine	Page 6-2
Jack-Up Points	Page 6-2
Inspection and Cleaning	Page 6-3
Engine	Page 6-3
Main Vehicle	Page 6-8
Supplying Fluids	Page 6-8
Engine	Page 6-8
Main Vehicle	Page 6-10
Greasing	Page 6-12
About Greasing	Page 6-12
Greasing Points	Page 6-13
Lubrication	Page 6-15
About Lubrication	Page 6-15
Lubricating Points	Page 6-16
Adjustment	Page 6-16
Engine	Page 6-16
Main Vehicle	Page 6-18
Replacement	Page 6-19
Engine	Page 6-19
Main Vehicle	Page 6-23
Storage	Page 6-28
Long-Term Storage	Page 6-28

Maintenance

Precautions for Maintenance

Warning

The chapter "Maintenance" in this manual describes practical measures which should be performed by a mechanic with expertise. The owner should instruct the mechanic with expertise to perform maintenance service for this machine.

Caution

First, learn well the operations you plan to perform.

Important

Use tools appropriate for each operation.

Important

Use Baronsess genuine parts for replacement and accessories. Our product warranty may be void if you use non-genuine parts for replacement or accessories.

Jacking Up The Machine

About Jacking Up The Machine

Warning

When replacing a tire or beginning any other maintenance or repairs, be sure to chock the wheels to prevent the machine from moving. Before jacking up the machine, park it on a hard, flat surface such as a concrete floor and remove any obstacles that could prevent you from performing the work safely. When necessary, use an appropriate chain block, hoist, or jack. Support the machine securely with jack stands or appropriate blocks. Failure to do so may cause the machine to move or fall, resulting in injury or death.

Important

Only place a jack under the jack-up points specified. Placing a jack at any other point will result in damage to the frame or other parts.

Use the jack-up points identified in this manual when jacking up the machine.

Jack-Up Points

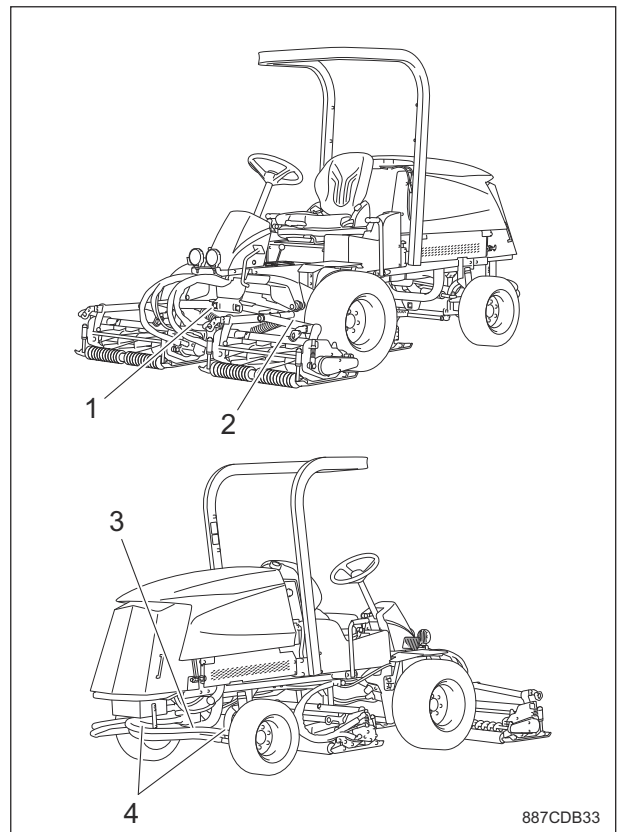

Jack-Up Points_001

Jack-up Points	
1	Front right frame
2	Front left frame
3	Rear frame
4	Pivot

1. Front right frame

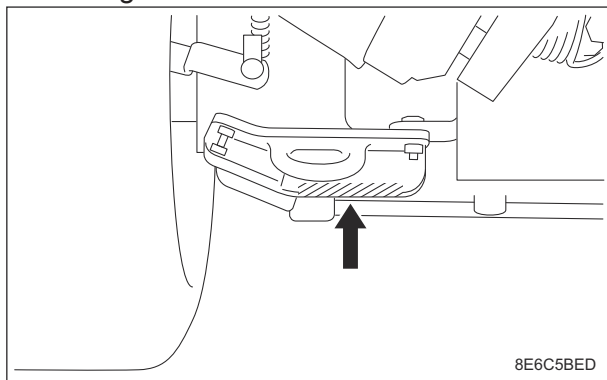

Jack-Up Points_002

2. Front left frame

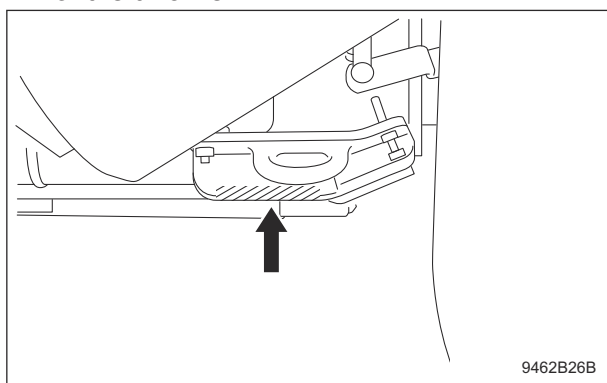

Jack-Up Points_003

3. Rear frame

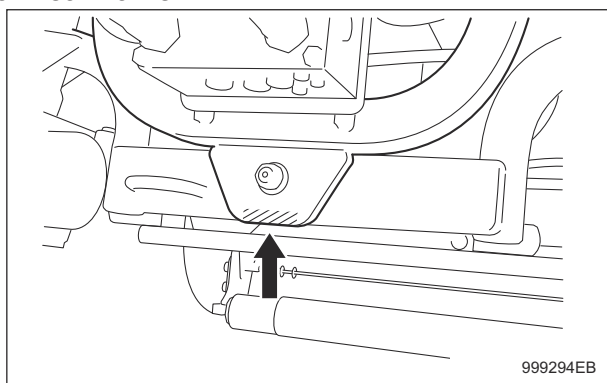

Jack-Up Points_004

4. Pivot

There are two locations.

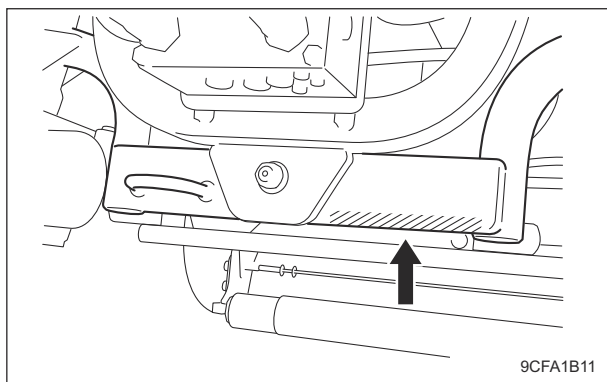

Jack-Up Points_005

Inspection and Cleaning

Inspect and clean the machine with the goals of the followings.

- Accident prevention
- Failure prevention
- Performance retention

Make efforts for early detection of the machine failure and prevention of the sudden occurrence of trouble.

Perform maintenance and repair works immediately if any abnormality is found in the machine.

Engine

Cleaning of Fuel Filter

1. Close the fuel cock on fuel filter.

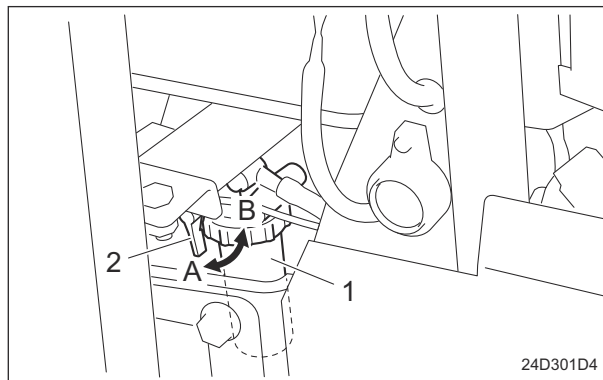

Cleaning of Fuel Filter_001

1	Fuel filter
2	Fuel cock
A	ON (Open)
B	OFF (Close)

Maintenance

2. Remove the retaining ring and then remove the cup.

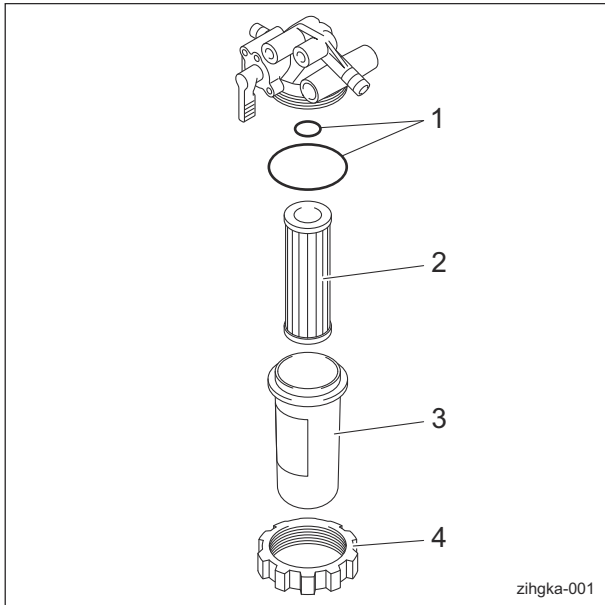

Cleaning of Fuel Filter_002

1	O-ring
2	Element
3	Cup
4	Retaining ring

3. Soak the filter element in diesel fuel and clean it.
4. Clean the inside of the filter cup with diesel fuel.

Important

While installing, be careful that it is not contaminated with dirt or dust. If the fuel is contaminated with dirt or dust etc., the fuel injection pump and injection nozzle will become worn.

5. Install the fuel filter and put the parts back together.

6. Fill up the fuel tank with fuel and open the fuel cock.

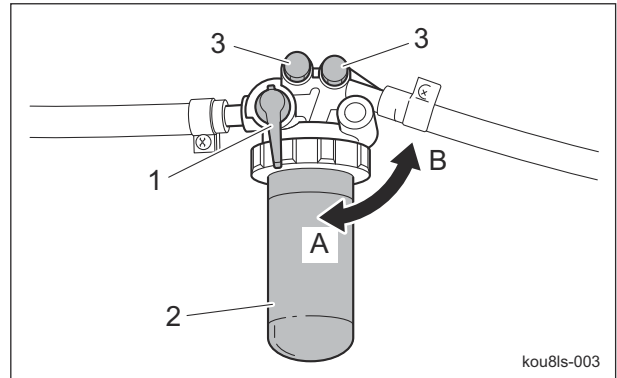

Cleaning of Fuel Filter_003

1	Fuel cock
2	Fuel filter
3	Air-bleeding plug
A	ON (Open)
B	OFF (Close)

7. Turn the key switch to the "ON" position. When the fuel pump is activated, the cup will be filled with fuel and air bleeding will occur automatically.
8. Switch the ignition key to the "START" position and remove air out of the fuel line.
9. If the engine does not start within 15 seconds after switching the ignition key to the "START" position, wait at least 30 seconds, and then repeat the same operation.

Inspection of Water Separator

Important

Water contamination in the fuel may decrease the engine starting performance and power output and may result in breakage of engine parts.

1. Make sure that the water separator is not damaged or dirty.
2. Make sure that there is no water leakage.
3. Make sure that debris and water have not accumulated in the cup.
With the float raised, water incorporation is confirmed.
When the float reaches the discharge level, discharge water.

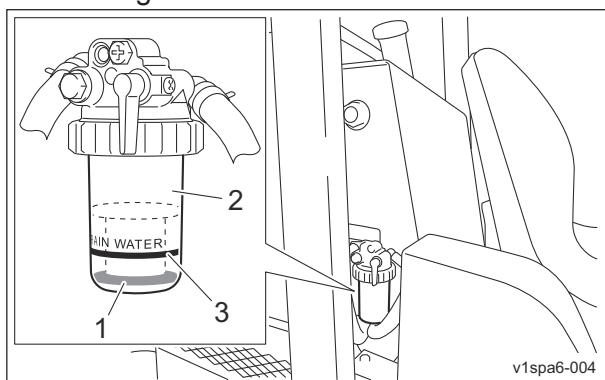

Inspection of Water Separator_001

1	Float
2	Cup
3	Discharge level

Draining of Water Separator

Important

Water contamination in the fuel may decrease the engine starting performance and power output and may result in breakage of engine parts.

Drain water from the water separator according to the maintenance schedule. And drain water whenever the float is raised by water.

1. Stop the engine, and then turn the key switch to the "OFF" position.
2. Place a container under the water separator.
3. Close the fuel filter cock.

4. Close the fuel cock of water separator.

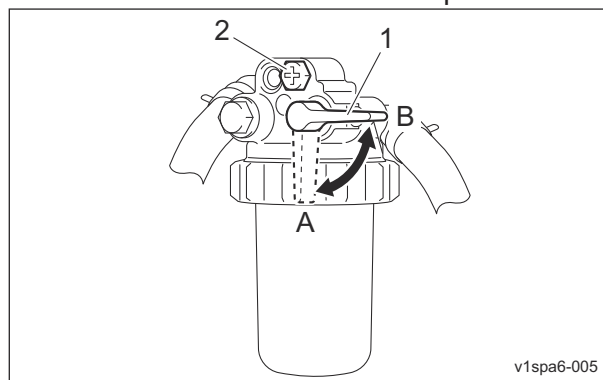

Draining of Water Separator_001

1	Fuel cock
2	Air-bleeding plug
A	ON (Open)
B	OFF (Close)

5. Remove the retaining ring and then remove the cup.

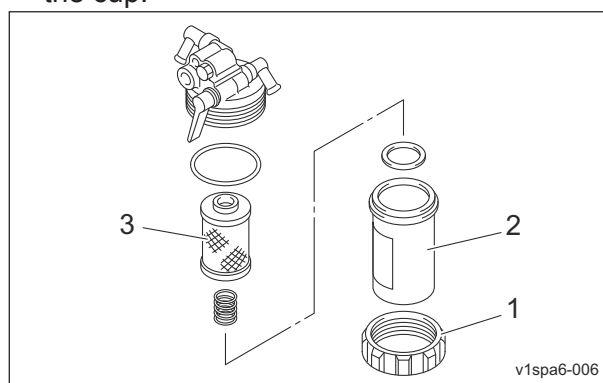

Draining of Water Separator_002

1	Retaining ring
2	Cup
3	Element

6. Discharge water from the cup.

Important

When installed, be careful that it is not contaminated with dirt or dust. If the fuel is contaminated with dirt or dust etc., the fuel injection pump and injection nozzle will become worn.

7. Put the parts back together.
8. Fill up the fuel tank with fuel and open the fuel cock.

Maintenance

9. Open the fuel cock of water separator.

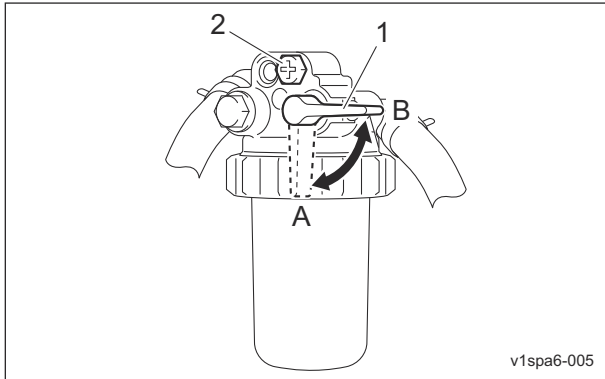

Draining of Water Separator_003

1	Fuel cock
2	Air-bleeding plug
A	ON (Open)
B	OFF (Close)

10. Loosen the air-bleeding plug by one turn.

11. Set the ignition key to the "ON" position.
After the fuel pump operated, the cup becomes filled with fuel and air bleeding occurs automatically.

12. Turn the key to the "START" position and remove air out of the fuel line.

13. In the case that there are still air bubbles in the fuel from air-bleeding plug even after 15 seconds or more pass after setting the ignition key to "START", pause for 30 seconds or more and then repeat the same steps.

14. Tighten the air-bleeding plug.

Cleaning of Water Separator

Important

Water contamination in the fuel may decrease the engine starting performance and power output and may result in breakage of engine parts.

Clean the water separator according to the maintenance schedule.

And clean it whenever debris has accumulated in the cup.

1. Stop the engine, and then turn the ignition key to the "OFF" position.
2. Place a container under the water separator.
3. Close the fuel filter cock.

4. Close the fuel cock of water separator.

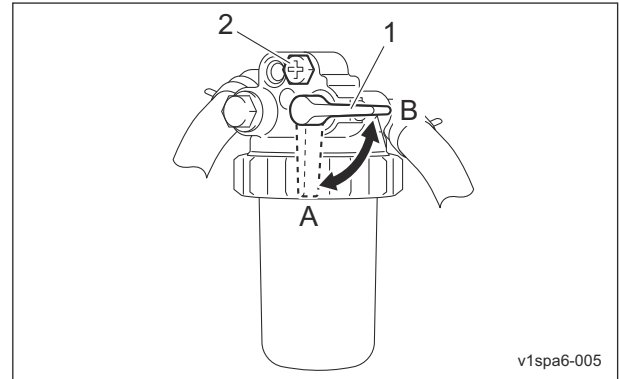

Cleaning of Water Separator_001

1	Fuel cock
2	Air-bleeding plug
A	ON (Open)
B	OFF (Close)

5. Remove the retaining ring and then remove the cup.

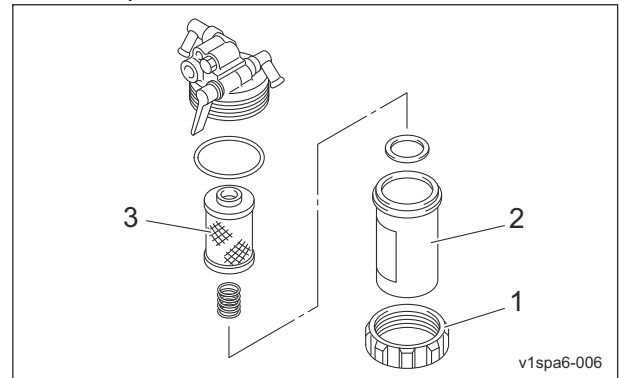

Cleaning of Water Separator_002

1	Retaining ring
2	Cup
3	Element

6. Discharge water from the cup.

7. Clean the cup and element with light oil.
Replace the element with new one as necessary.

Important

When installed, be careful that it is not contaminated with dirt or dust.
If the fuel is contaminated with dirt or dust etc., the fuel injection pump and injection nozzle will become worn.

8. Put the parts back together.

9. Fill up the fuel tank with fuel and open the fuel cock.

10. Open the fuel cock of water separator.

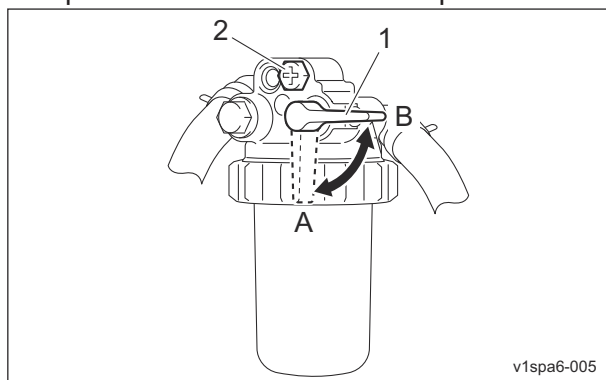

Cleaning of Water Separator_003

1	Fuel cock
2	Air-bleeding plug
A	ON (Open)
B	OFF (Close)

11. Loosen the air-bleeding plug by one turn.
 12. Set the ignition key to the "ON" position.
 After the fuel pump operated, the cup becomes filled with fuel and air bleeding occurs automatically.
 13. Turn the key to the "START" position and remove air out of the fuel line.
 14. In the case that there are still air bubbles in the fuel from air-bleeding plug even after 15 seconds or more pass after setting the ignition key to "START", pause for 30 seconds or more and then repeat the same steps.
 15. Tighten the air-bleeding plug.

Cleaning of Air Cleaner Element

A contaminated air cleaner element may cause malfunction of the engine.
 To maximize the life of the engine, clean the air cleaner properly.

1. Remove the clips, and then remove the air cleaner cap.
2. Remove the air cleaner filter.
3. While paying close attention not to damage the air cleaner filter, tap a solid portion of the air cleaner filter or blow compressed air from its inside to remove dust and dirt.
 If the air cleaner filter is extremely contaminated, replace it with a new one.
4. Attach the air cleaner filter to the air cleaner body.

5. Replace the air cleaner cap, and then fix it securely with the clips.

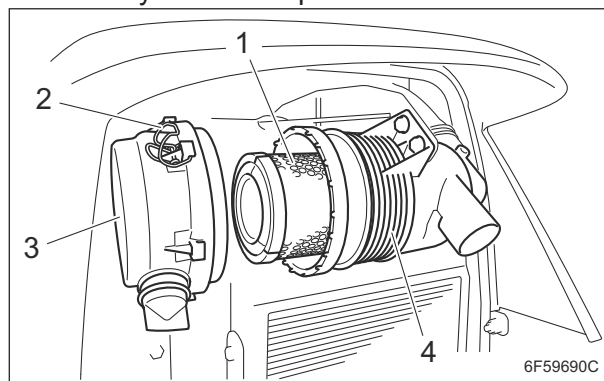

Cleaning of Air Cleaner Element_001

1	Air cleaner filter
2	Clip
3	Air cleaner cap
4	Air cleaner body

Inspection of Belt

Warning

The engine must be stopped when the belt is inspected.

Important

A slacking or damaged belt or damaged fan may cause overheating or lack of a battery charge.

1. Check the belt tension.
2. Make sure that there are no cracks and damage on the belt.
3. Make sure that there is no abnormal wear on the belt.

Maintenance

Main Vehicle

Inspection of Hydraulic Hoses and Pipes

Warning

When checking the hydraulic circuit for pinhole leaks or oil leakage from nozzles, do not use your hands. Use items such as paper or corrugated cardboard to find leakage points.

Be extremely careful with high-pressure oil as it may pierce your skin, resulting in personal accidents.

If fluid is injected into the skin it must be surgically removed within a few hours by a doctor familiar with this form of injury or gangrene may result.

1. Make sure that there is no wear, deterioration or damage in the hydraulic hoses and pipes.
2. Make sure that there is no looseness in the connecting portion of the hydraulic hoses and pipes.
3. Check underneath the machine for hydraulic oil leakage.

Inspection of Electrical Wiring

Important

Electrical short circuit will cause fire, electrical leakage and malfunction of electrical equipments.

1. Make sure that there is no defacement in wires and terminals.
2. Make sure that there is no deterioration or damage in wires and terminals.
3. Make sure that there is no looseness in wiring connections.
4. Make sure that there is no poor terminal connection.

Inspection of Wheel Mounting Bolt

Important

Tighten the wheel mounting bolts on the specified torque by using a torque wrench.

1. Check the wheel mounting bolts and wheel nuts for looseness and coming off.

2. Check the wheel mounting bolts and wheel nuts for cracks and damages.
3. Check the wheel mounting bolts and wheel nuts for rust.
4. Check around the wheel mounting bolts and wheel nuts for traces of rust fluid.
5. Check the wheel mounting bolts for unequal bolt length.
6. Check the wheel mounting bolts and wheel nuts for stripped threads and abrasion.

Supplying Fluids

Engine

Supply of Engine Oil

Caution

Keep fire away while supplying the engine oil. Do not smoke.

Important

Do not supply too much engine oil. Otherwise, the engine may be damaged.

Important

Do not mix different types of engine oil.

Important

Be sure to use engine oil that is classified as API Service Grade CF or higher, with an SAE Viscosity that is appropriate for the operating environment (ambient temperature).

Important

Securely install the oil level gauge and oil filler cap.

If the engine oil level is lower than the lower limit on the oil level gauge, supply engine oil. Supply engine oil through the oil filler port.

1. Place the machine to set the engine on the level.
2. Stop the engine.
3. Open the hood.

4. Remove the oil filler cap.

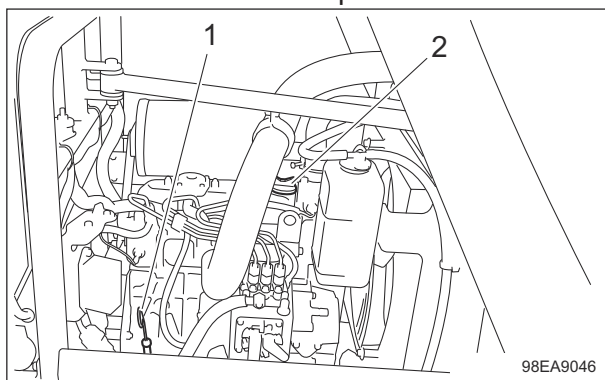

Supply of Engine Oil_001

1	Oil level gauge
2	Oil filler cap

5. Supply new engine oil through the oil filler port.

Supply until the oil reaches a level in between the upper and lower limit lines on the oil level gauge.

6. Securely install the oil filler cap.

7. It will take a while for the supplied engine oil to descend into the oil pan.

Check the oil level again 10 to 20 minutes after supplying the engine oil.

If the engine oil level is low, supply oil again until it reaches the specified level.

8. Close the hood.

Supply of Coolant

Caution

Do not touch the radiator or coolant during engine operation or right after the engine has been turned off.

Otherwise, you may get burned due to high temperatures.

Open the radiator cap after the radiator has well cooled down.

Caution

Supply coolant after the engine has well cooled down.

Caution

The radiator cap is pressurized. If you remove the radiator cap while the engine is overheated, hot steam will burst out, possibly resulting in burns. Make sure that the water temperature and pressure are reduced, and then grab the cap with a thick cloth and gradually open the cap.

Important

When you supply coolant, be sure to mix clean water and antifreeze (long-life coolant), and then pour it into the radiator and reserve tank.

Important

Tightly close the radiator cap. If the cap is loose or incorrectly installed, the engine will be overheated due to water leakage, resulting in engine damage.

When mixing antifreeze and clean water, refer to "Relationship between concentration of long-life coolant (LLC) and freezing temperature" below for the mixing ratio. Relationship between concentration of long-life coolant (LLC) and freezing temperature

Freezing temperature	LLC concentration (volume %)
Down to -10 °C (14 °F)	20 %
Down to -15 °C (5 °F)	30 %
Down to -20 °C (-4 °F)	35 %
Down to -25 °C (-13 °F)	40 %

If the coolant level in the reserve tank is low, supply clean water and antifreeze.

1. If the coolant level in the reserve tank is lower than the "LOW" mark, follow the steps below to fill the tank.

[1] Remove the reserve tank cap.

[2] Supply clean water and antifreeze up to the "FULL" mark of the reserve tank.

Maintenance

[3] Install the reserve tank cap.

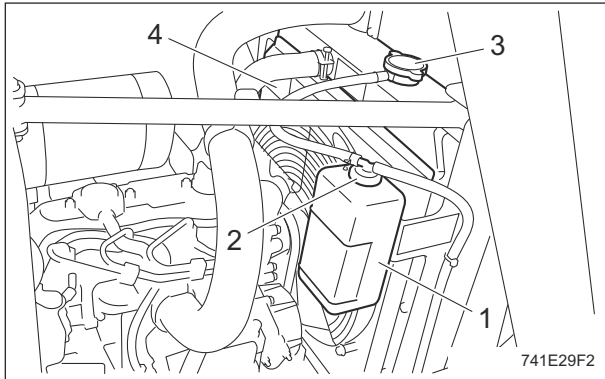

Supply of Coolant_001

1	Reserve tank
2	Reserve tank cap
3	Radiator cap
4	Radiator

2. If no coolant is in the reserve tank, follow the steps below to fill the tank.
 - [1] Remove the radiator cap.
 - [2] Supply clean water and antifreeze up to the opening of the radiator.
 - [3] Install the radiator cap.
 - [4] Remove the reserve tank cap.
 - [5] Supply clean water and antifreeze up to the "FULL" mark of the reserve tank.
 - [6] Install the reserve tank cap.

Main Vehicle

Supply of Hydraulic Oil

⚠ Caution

Keep fire away while supplying the hydraulic oil.
Do not smoke.

Important

Do not mix different types of oil.

Important

For the hydraulic oil to be used, consult Characteristics of Hydraulic Oil and use the oil whose characteristics are equivalent or superior to those specified there. Especially regarding kinematic viscosity and viscosity index, use of hydraulic oil whose figures are less than those of the specified hydraulic oil will cause a malfunction in the hydraulic circuit.

Important

Supply hydraulic oil after checking the oil in the hydraulic tank has been sufficiently cooled down.

Oil level changes depending on the hydraulic oil temperature.

■ Characteristics of Hydraulic Oil

ISO Viscosity Grade		ISO VG46
Density	15 °C (59 °F)	0.873 g/cm ³ (0.0315 lb/in ³)
API Gravity		30.6
Flash Point (Open Cup)		230 °C (446 °F)
Pour Point		-30 °C (-22 °F)
Kinematic Viscosity	40 °C (104 °F)	46 mm ² /s (46 cSt)
	100 °C (212 °F)	7 mm ² /s (7 cSt)
Viscosity Index		109

■ Characteristics of Hydraulic Oil with conditions of use

Hydraulic oil of ISO viscosity grade VG68 can be used only if the following condition is met:

- The outside temperature must be 20 °C (68 °F) or more during engine operation.

ISO Viscosity Grade		ISO VG68
Density	15 °C (59 °F)	0.878 g/cm ³ (0.0318 lb/in ³)
API Gravity		29.7
Flash Point (Open Cup)		252 °C (486 °F)
Pour Point		-30 °C (-22 °F)
Kinematic Viscosity	40 °C (104 °F)	68 mm ² /s (68 cSt)
	100 °C (212 °F)	9 mm ² /s (9 cSt)
Viscosity Index		107

Note:

In Japan, "Shell Tellus S2M46 (ISO VG46)" and "Shell Tellus S2M68 (ISO VG68)" meet the characteristics described above.

However, in other countries, the specification of Shell Tellus S2M46 and Shell Tellus S2M68 can be below what is required.

Please check the product data sheet to ensure that it meets the requirements before using.

If the hydraulic oil level is low, follow the steps below to supply hydraulic oil.

1. Lower the mower unit on a level surface, and stop the engine.
2. Open the center cover.
3. Loosen the bushing with a wrench (accessory, #10076-) and remove the oil filler plug.
4. Supply hydraulic oil from the fill port until the oil level reaches the middle of the oil gauge on the hydraulic tank.
5. Install the oil filler plug and tighten the bushing securely.

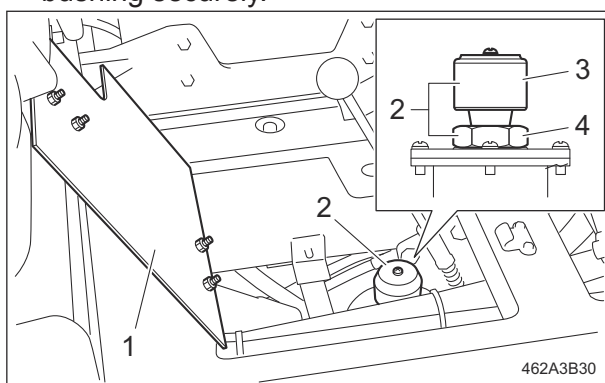

Supply of Hydraulic Oil_001

1	Center cover
2	Oil filler plug
3	Air breather
4	Bushing

6. Close the center cover.
7. Start the engine, and then repeat the steps below a few times.
 - Raise and lower the mower units.
 - Turn the steering wheel left and right.
 - Move forward and reverse.
8. Lower the mower units and maintain that position on a level surface, and then check to see if the oil level is at the middle of the oil gauge.
If the hydraulic oil level is low, supply oil again until it reaches the specified level.
9. Check underneath the machine for oil leakage.

Maintenance

Supply of Battery Fluid

⚠ Danger

If battery fluid comes into contact with eyes, it may result in blindness. Immediately flush with plenty of water and take medical care from an ophthalmologist.

⚠ Danger

Do not drink battery fluid.
If battery fluid enters the mouth or is swallowed, it may result in burns inside the mouth. Immediately and repeatedly gargle with plenty of water, then drink plenty of water, and take medical care.

⚠ Danger

When you supply battery fluid, wear protective garments and safety glasses, etc.

⚠ Warning

If battery fluid adheres to the skin or clothing, it may cause burns or damage clothing. Immediately flush with plenty of water, then wash thoroughly with soap.

⚠ Warning

Do not allow the battery fluid level to become lower than the LOWER LEVEL (minimum fluid level line).
The battery may explode if it is used or charged while the battery fluid level is at the LOWER LEVEL (minimum fluid level line).

⚠ Warning

When refilling, do not fill purified water above the UPPER LEVEL (maximum fluid level line). Doing so may result in electrolyte leaks.

⚠ Caution

Implement after the engine and muffler etc. have well cooled down.
Otherwise, you may get burned.

Important

If battery fluid adheres to the vehicle, it may cause corrosion.
Wipe it off with a cloth dampened with water, and then flush with water.

If the battery fluid level is lower than halfway between the UPPER LEVEL (maximum fluid level line) and LOWER LEVEL (minimum fluid level line), add purified water.

1. Loosen the vent plug and remove it.
2. Add purified water up to the UPPER LEVEL (maximum fluid level line)
3. Tighten the vent plug securely.

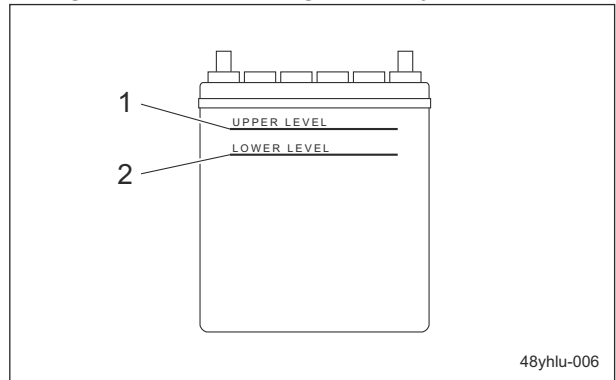

Supply of Battery Fluid_001

1	Maximum fluid level line
2	Minimum fluid level line

Greasing

About Greasing

Since there may be adhesion or damage due to lack of grease on moving parts, they must be greased.

Add urea-based No. 2 grease in accordance with the Maintenance Schedule.

Other locations where the specified grease or lubricant is used are indicated in "Greasing Points".

Add grease using the specified grease or lubricant.

Greasing Points

Grease nipples are installed in the following locations.

Add grease every 50 hours of operation. If specified locations, periods and grease are additionally described below, follow the instructions.

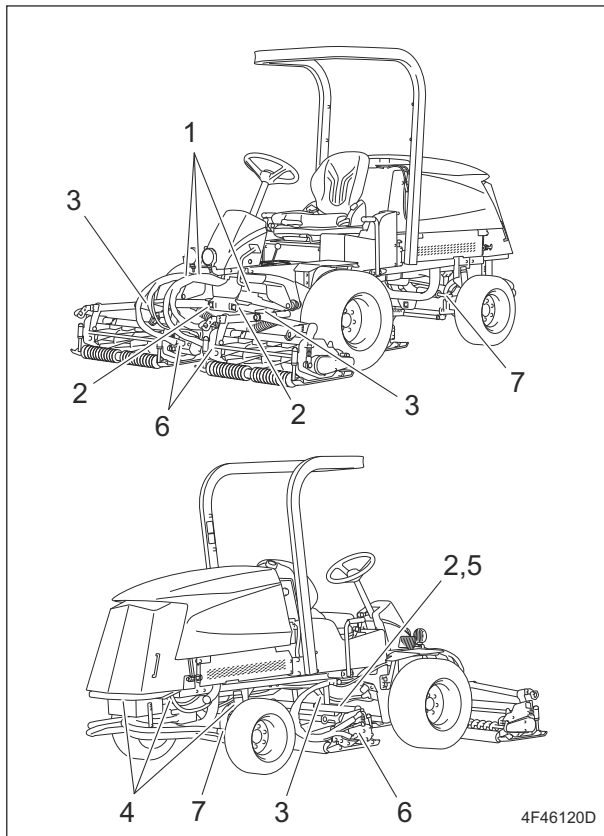

Greasing Points_001

	Location	No. of greasing points
1	Pedal shaft fulcrum	3
2	Lift arm fulcrum	3
3	Mower unit fulcrum	3
4	Pivot	3
5	Cylinder shaft	1
6	Reel motor shaft	3
7	Tie rod end (#10145-)	2

1. Pedal shaft fulcrum
Traveling Pedal
There are two greasing points.

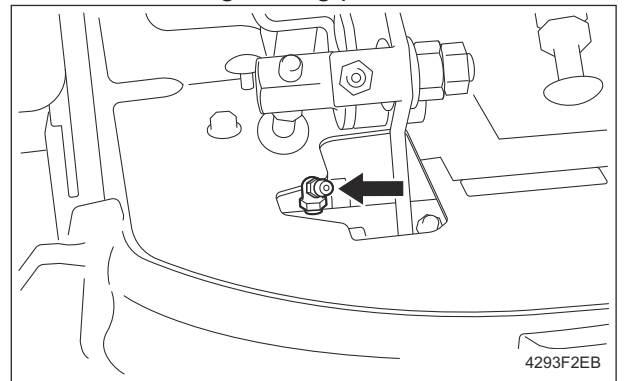

Greasing Points_002

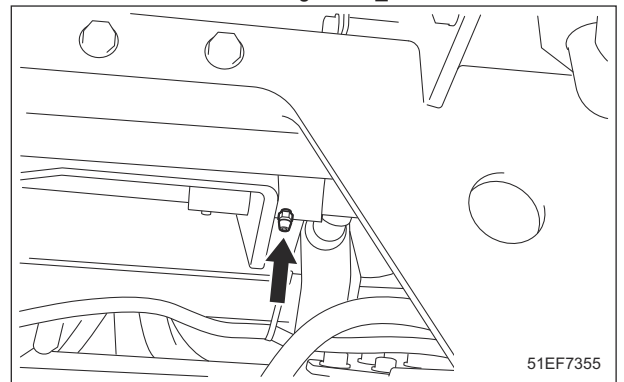

Greasing Points_003

Brake pedal

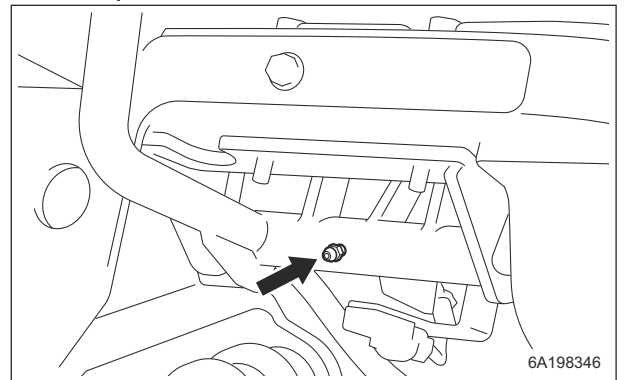

Greasing Points_004

Maintenance

2. Lift arm fulcrum

There is one greasing point on each lift arm fulcrum connected to the mower unit.
Before greasing a lift arm fulcrum, lower the mower unit.

Mower unit #1

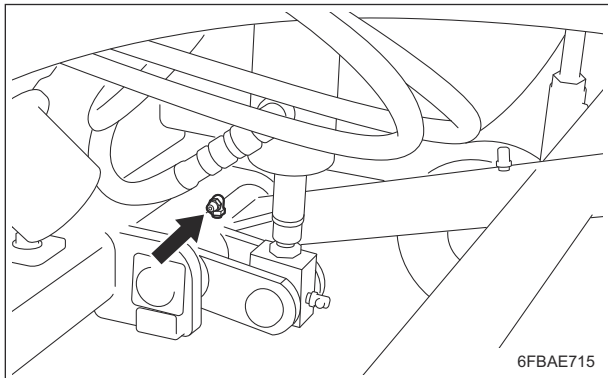

Greasing Points_005

Mower unit #2 and 3

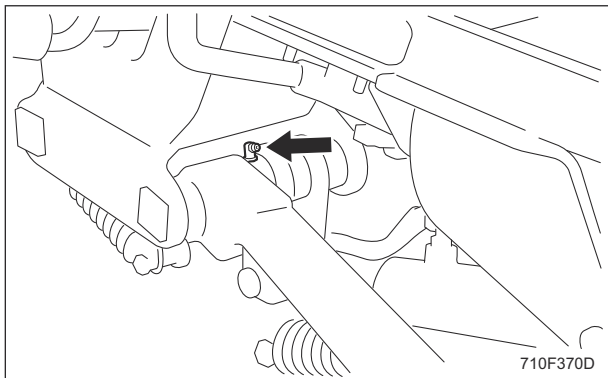

Greasing Points_006

3. Mower unit fulcrum

There is one greasing point on each mower unit.

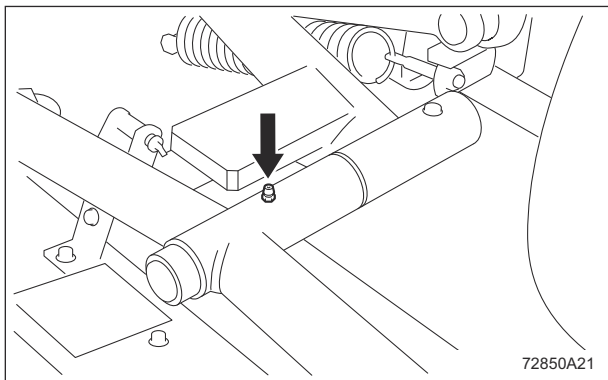

Greasing Points_007

4. Pivot

There are three greasing points.
Middle between rear wheels

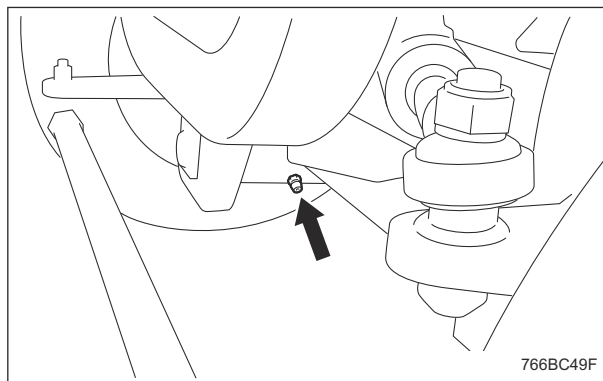

Greasing Points_008

Rear left wheel

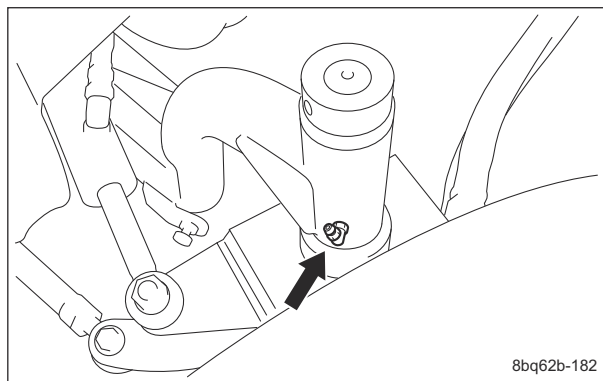

Greasing Points_009

Rear right wheel

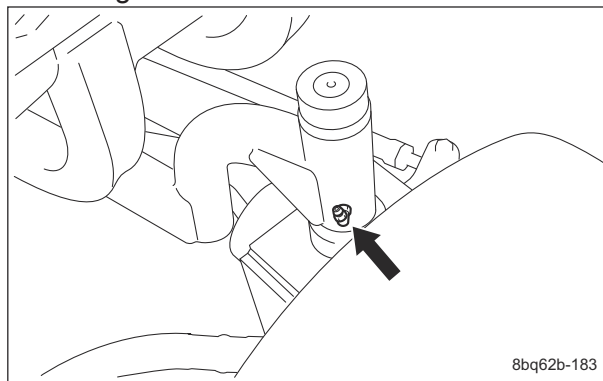

Greasing Points_010

5. Cylinder shaft

Cylinder shaft #1

There is one greasing point on the cylinder shaft.

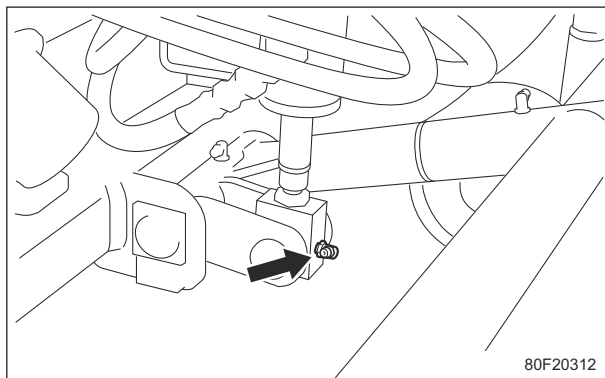

Greasing Points_011

6. Reel motor shaft

Apply 2 g (0.004 lb) of MOLY SPEED GREASE NO.2 to the reel motor shaft mounted on each mower unit every 250 hours.

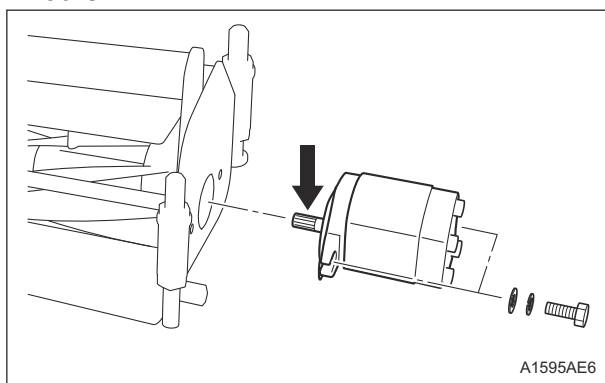

Greasing Points_012

7. Tie rod end

There is one point each on the left and right tie rod ends.

Add 9 g (0.02 lb) of DYNAMAX GREASE EP NO.1 every 3 months of operation.

Note:

Add grease with the steering wheel turned to the left/right completely.

The appropriate greasing amount is that it sticks out a little from the tie rod end rubber boot.

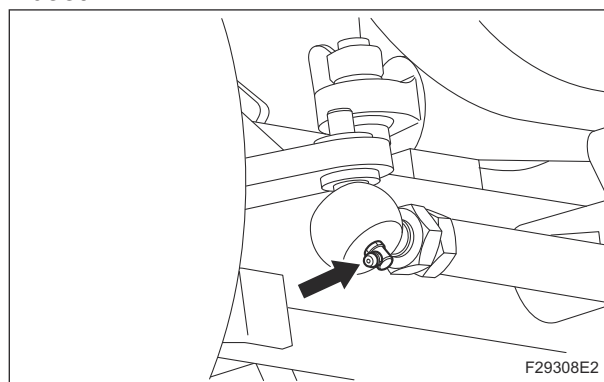

Greasing Points_013

Lubrication

About Lubrication

It is necessary to lubricate moving parts so that they will not become stuck or damaged.

The locations where lubricant is used are indicated in "Lubricating Points".

Apply the lubricant.

Maintenance

Lubricating Points

Apply lubricant at the following locations every 50 hours of operation.

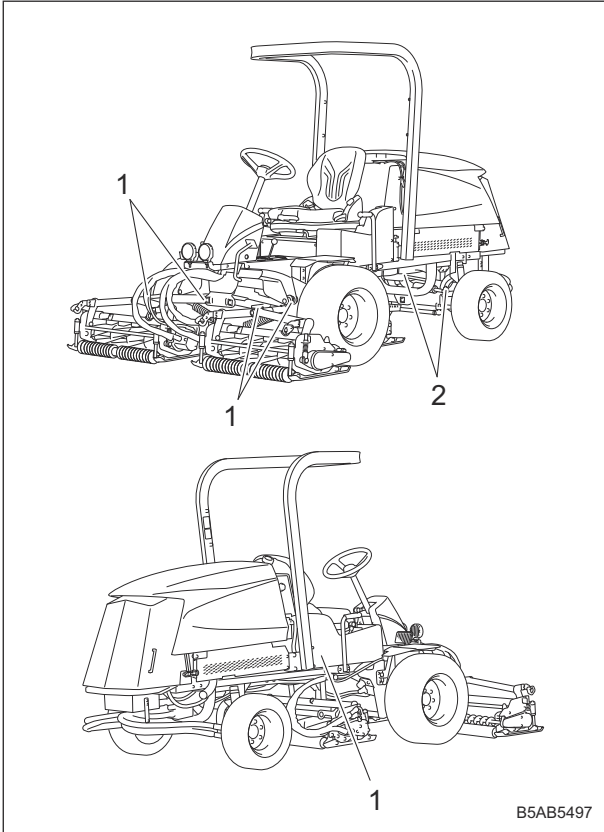

Lubricating Points_001

	Location	No. of greasing points
1	Mower cylinder spherical bearing	5
2	Steering cylinder spherical bearing	2

1. Mower cylinder spherical bearing
Mower cylinder #1
There is one point on the mower cylinder.

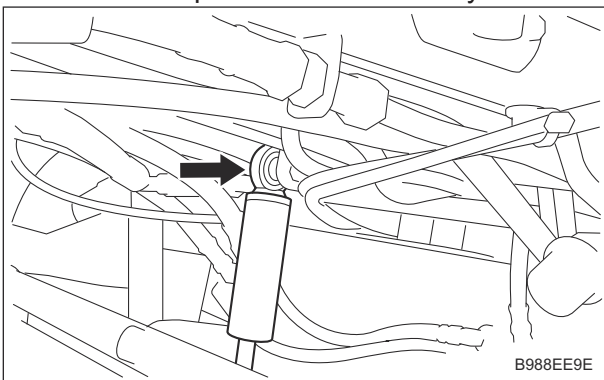

Lubricating Points_002

- Mower cylinder #2 and 3
There are two points on each mower cylinder.

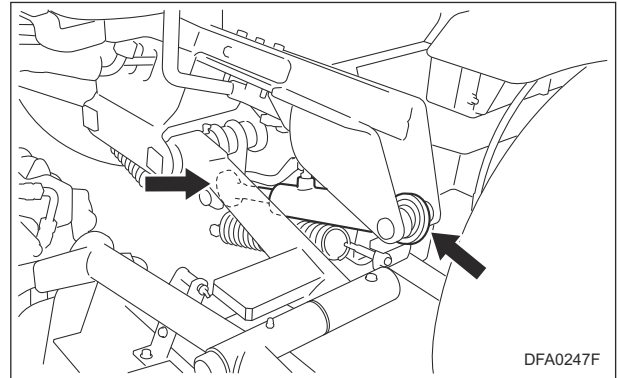

Lubricating Points_003

2. Steering cylinder spherical bearing
There are two points on the rear wheel area.

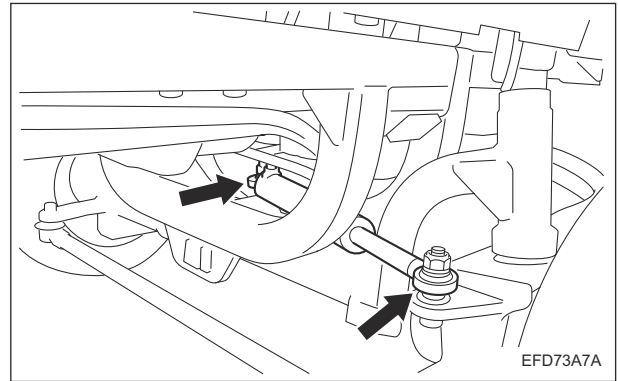

Lubricating Points_004

Adjustment

Engine

Adjustment of Fan Belt



Warning

Be sure to stop the engine before inspecting or adjusting the fan belt.



Warning

If a cover is removed due to inspection or adjustment, be sure to reinstall it in its original location.



Important

A slacking or damaged fan belt will cause overheating or lack of battery charge. Adjust or replace the belt.

For fan belt adjustment, follow either of the methods below.

1. Adjustment on the basis of belt slack deviation when applying a specified load to a specified place

- [1] Press the middle of the belt with your finger to check the belt tension.
The belt tension is appropriate when the belt slacks by approximately 10 mm (0.39 in) when you apply a force of 98 N (10 kgf) to the belt at the middle point between the pulleys.
- [2] If the belt tension is incorrect, loosen bolt A, nut and bolt B for securing the alternator, and then move the alternator to adjust the tension.
- [3] Be sure to tighten bolt A, nut and bolt B securely after adjustment.
- [4] After adjustment of belt tension, check the belt tension again.
If the belt tension is still not at the appropriate value after repeating the adjustment several times, replace the belt with a new one.

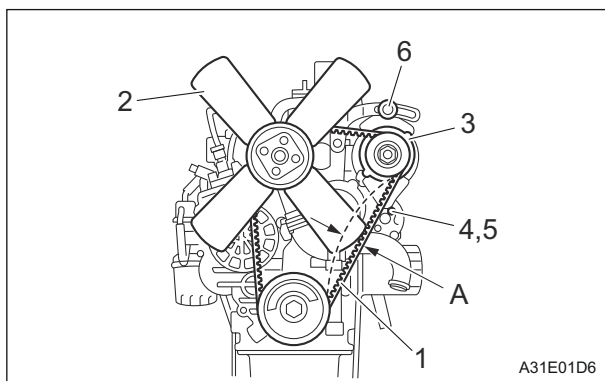

Adjustment of Fan Belt_001

1	Fan Belt
2	Blade
3	Alternator
4	Bolt A
5	Nut
6	Bolt B
A	10 mm (0.39 in)

2. Adjustment to suitable belt tension force by using sonic type tension meters at a specified point

Important

Perform correct measurement in accordance with the operations manual of the equipment being used for tension measurement.

Important

Perform measurement immediately after mounting the belt, when the pulley is not rotating.

- [1] Measure belt tension force by using a sonic type tension meter.
For measurement position and distance between pulleys, see diagram below.
Here is the suitable belt tension force.

Adjustment	200 – 300 N (20.39 - 30.59 kgf)
Replacement	267 – 361 N (27.23 - 36.81 kgf)

- [2] If the belt tension is inappropriate, loosen bolt A, nut and bolt B for securing the alternator, and then move the alternator to adjust the tension.
- [3] Be sure to tighten bolt A, nut and bolt B securely after adjustment.
- [4] After adjustment of belt tension, check the belt tension again.
If the belt tension is still not at the appropriate value after repeating the adjustment several times, replace the belt with a new one.

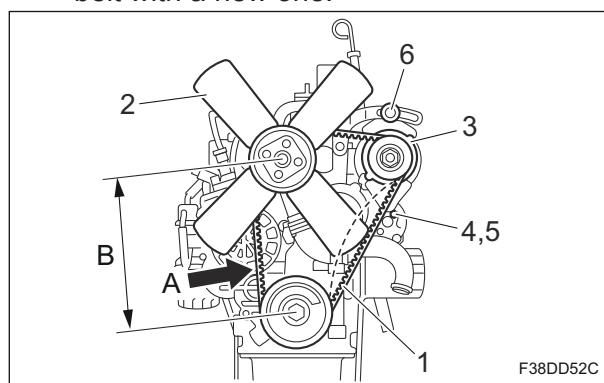

Adjustment of Fan Belt_002

Maintenance

1	Fan belt
2	Blade
3	Alternator
4	Bolt A
5	Nut
6	Bolt B
A	Measurement position
B	Distance between pulleys

Main Vehicle

Adjustment of Lift Arm Spring

Important

Adjust the spring if the front wheels slip on an ascending slope.

1. Raise the mower units.
2. Adjust the length of the lift arm spring with lock nut A and lock nut B. Increasing the length of the spring will improve the hill-climbing ability.
3. Perform the same procedure for the lift arm springs of both left and right mower units. Make an adjustment so that the lift arm spring will be compressed evenly.

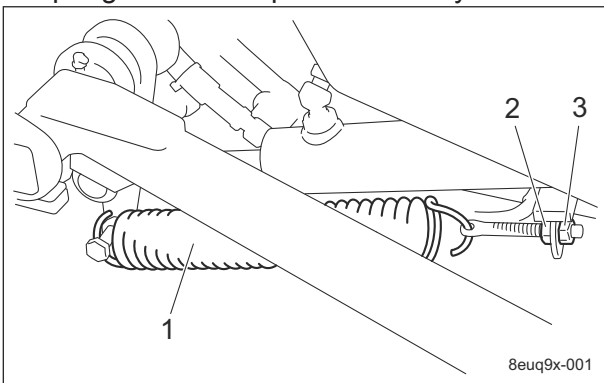

Adjustment of Lift Arm Spring_001

1	Lift arm spring
2	Lock nut A
3	Lock nut B

Adjustment of Mower Stopper

■ Adjustment of Mower Stoppers for Mower Unit #1

The mower stopper is installed to prevent the mower unit from interfering with the frame.

1. Loosen the nuts of the left and right mower stoppers.
2. Place the left and right mower stoppers to the highest position and attach them temporarily.
3. Start the engine.
4. On a level surface, raise all mower units.
5. Apply the parking brake.
6. Stop the engine.
7. Tighten the nuts of the left and right mower stoppers in a position where the mower unit is leveled and the mower arm contacts the mower stoppers.

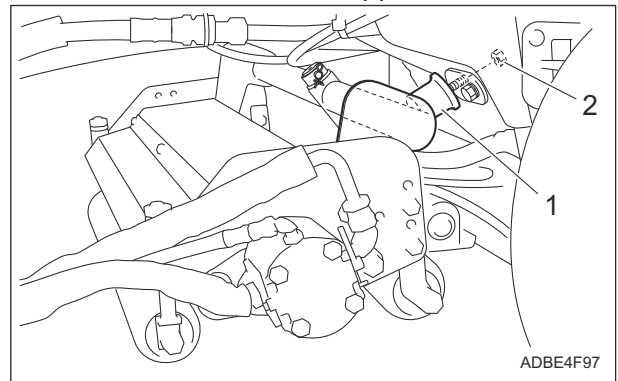

Adjustment of Mower Stoppers for Mower Unit #1_001

1	Mower stopper
2	Nut

Replacement

Engine

Replacement of Engine Oil

⚠ Caution

Be careful with hot oil, which could cause burns if it contacts your skin.

⚠ Caution

Change oil after the engine has been well cooled down.

Important

When you change the engine oil, be sure to drain it into a bowl and discard it in accordance with local laws and regulations.

Important

Be sure to use engine oil that is classified as API Service Grade CF or higher, with an SAE Viscosity that is appropriate for the operating environment (ambient temperature).

Important

Securely install the oil level gauge and oil filler cap.

Change the engine oil more frequently if the engine oil is contaminated, and especially when you use the machine in dusty areas or operate the engine at high loads or in high temperatures.

1. Follow the steps below to remove the old engine oil.

[1] Start and run the engine to warm up the engine oil.

[2] Stop the engine on a level surface.

- [3] Remove the drain plug while the engine oil is warm, and then drain the old engine oil into a container.

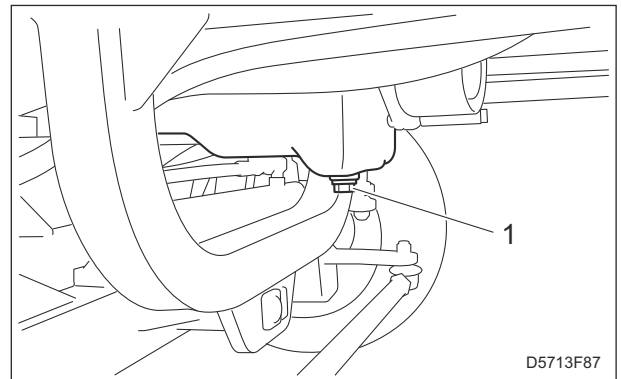

Replacement of Engine Oil_001

1	Drain plug
---	------------

- [4] Re-place the drain plug.

2. Remove the oil filler cap, and then supply new engine oil until the oil reaches a level in between the upper and lower limit lines on the oil level gauge.

Engine oil quantity is approximately 3.0 dm³ (3.0 L).

3. Securely install the oil filler cap.

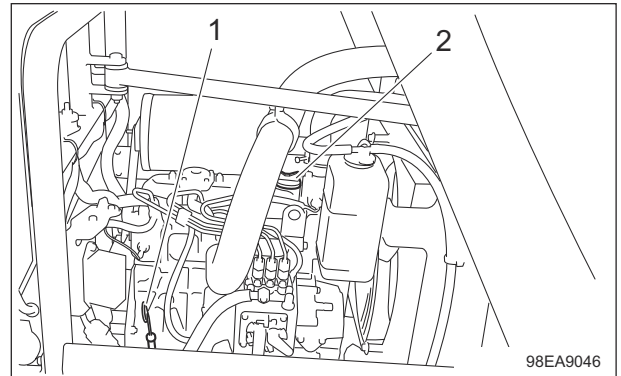

Replacement of Engine Oil_002

1	Oil level gauge
2	Oil filler cap

4. It will take a while for the supplied engine oil to descend into the oil pan. Check the oil level again 10 to 20 minutes after supplying the oil.
5. Check underneath the machine for hydraulic oil leakage.

Maintenance

Replacement of Engine Oil Filter

Caution

Be careful with hot oil, which could cause burns if it contacts your skin.

Caution

Change filter after the engine has been well cooled down.

Important

When replacing the engine oil filter, be sure to drain the engine oil into a container and discard it in accordance with local laws and regulations.

Important

Be sure to use engine oil that is classified as API Service Grade CF or higher, with an SAE Viscosity that is appropriate for the operating environment (ambient temperature).

Important

Securely install the oil level gauge and oil filler cap.

1. With the filter wrench, remove the old filter cartridge.

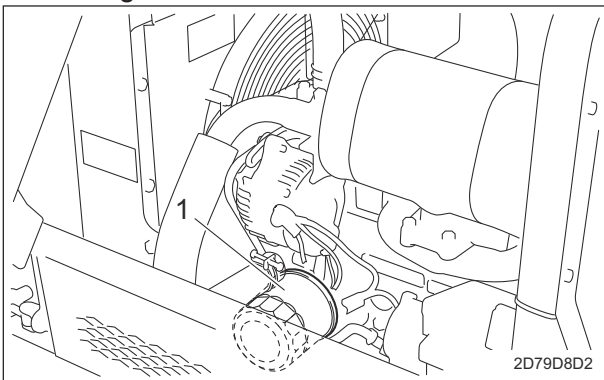

Replacement of Engine Oil Filter_001

1 Filter cartridge

2. Lightly coat the packing of the new filter cartridge with engine oil.
3. Screw the filter cartridge by hand until the packing contacts the sealing surface, and then firmly hand-tighten (without using a filter wrench).

4. Supply engine oil until it reaches the specified level.
"Supply of Engine Oil" (Page 6-8)
5. Start the engine, and then stop it after 10 to 20 minutes.
6. Make sure that there is no oil leakage at the sealing surface of the filter cartridge.
7. Check the engine oil level.
If it is low, supply engine oil until it reaches the specified level.

Replacement of Fuel Filter Element

1. Close the fuel filter cock.

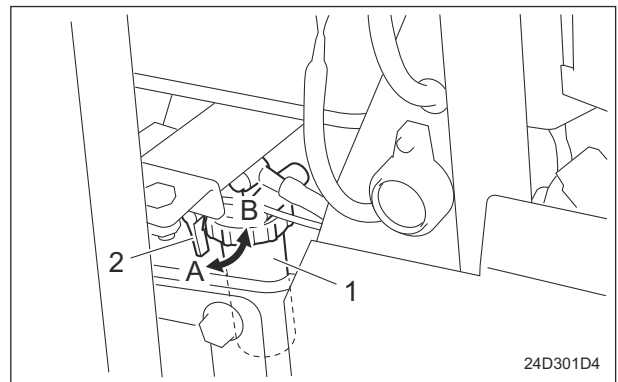

Change of Fuel Filter Element_001

1	Fuel filter
2	Fuel cock
A	ON (Open)
B	OFF (Close)

2. Remove the retaining ring and then remove the cup.

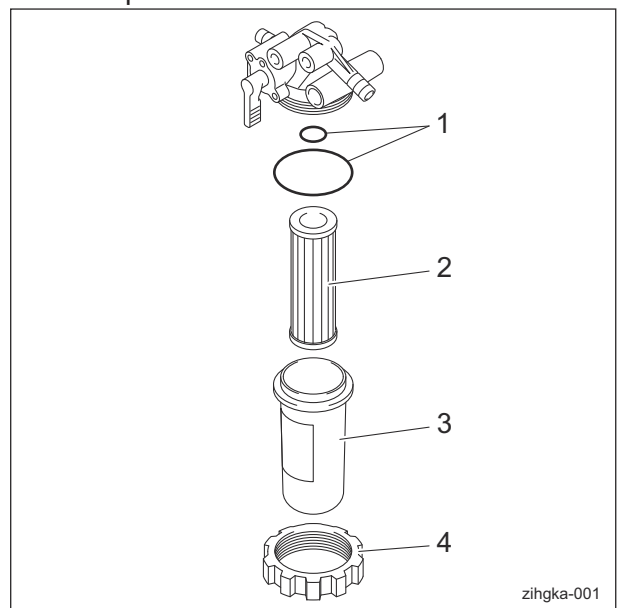

Change of Fuel Filter Element_002

1	O-ring
2	Element
3	Cup
4	Retaining ring

3. Clean inside of the cup with diesel fuel.

Important

When installed, be careful that it is not contaminated with dirt or dust. If the fuel is contaminated with dirt or dust etc., the fuel injection pump and injection nozzle will become worn.

4. Install a new element and put the parts back together.
5. Fill up the fuel tank with fuel and open the fuel cock.

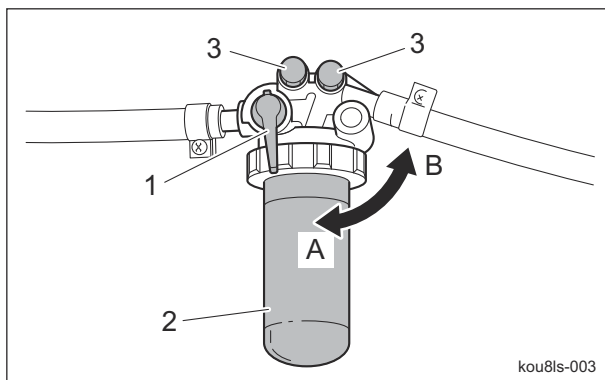

Change of Fuel Filter Element_003

1	Fuel cock
2	Fuel filter
3	Air-bleeding plug
A	ON (Open)
B	OFF (Close)

6. Turn the key switch to the "ON" position. When the fuel pump is operated after replacement, air bleeding will occur automatically.
7. Turn the ignition key to the "START" position and remove air out of the fuel line.
8. If the engine does not start within 15 seconds after switching the ignition key to the "START" position, wait at least 30 seconds, and then repeat the same operation.

Replacement of Air Cleaner Element

Important

A contaminated air cleaner element may cause malfunction of the engine.

1. The timing for replacing the air cleaner element is described below.
 - [1] Replace the air cleaner element in accordance with the Maintenance Schedule.
 - [2] If it is significantly contaminated, replace it, even if the hours of operation do not exceed the specified time.
2. Replace the air cleaner element by following the same steps as for cleaning the air cleaner element. "Cleaning of Air Cleaner Element" (Page 6-7)

Maintenance

Replacement of Coolant

⚠ Caution

Do not touch the radiator or coolant during engine operation or immediately after the engine has been turned off. Otherwise, you may get burned.

⚠ Caution

Change coolant after the engine has been well cooled down.

⚠ Caution

The radiator cap is pressurized. If you remove the radiator cap while the engine is overheated, hot steam will burst out, possibly resulting in burns. Make sure that the water temperature and pressure are reduced, and then grab the cap with a thick cloth and gradually open the cap.

Important

When changing the coolant, be sure to drain it into a container and discard it in accordance with local laws and regulations.

Important

When changing the coolant, be sure to mix clean water (soft water) and antifreeze (long-life coolant), and then pour it into the radiator and reserve tank.

Important

Tightly close the radiator cap. If the cap is loose or incorrectly installed, the engine will be overheated due to water leakage, resulting in engine damage.

When mixing antifreeze and clean water (soft water), refer to "Relationship between concentration of long-life coolant (LLC) and freezing temperature" below for the mixing ratio.

Relationship between concentration of long-life coolant (LLC) and freezing temperature

Freezing temperature	LLC concentration (volume %)
Down to -10 °C (14 °F)	20 %
Down to -15 °C (5 °F)	30 %
Down to -20 °C (-4 °F)	35 %
Down to -25 °C (-13 °F)	40 %

1. Stop the engine, and then cool down the radiator.
2. Open the hood.
3. Follow the steps below to drain the coolant.
 - [1] Position a container to drain the coolant into.
 - [2] Loosen the drain cock of the radiator.

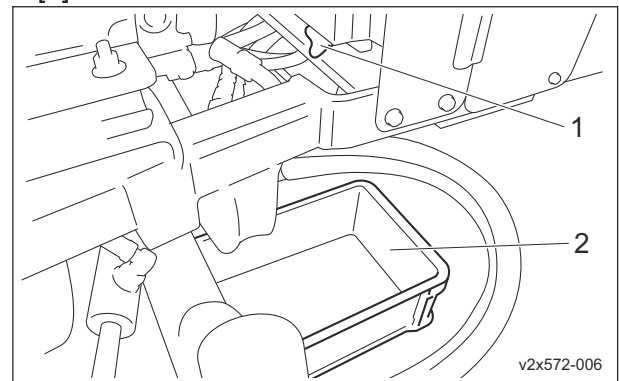

Replacement of Coolant_001

1	Radiator drain cock
2	Container

- [3] Remove the radiator cap and drain the coolant.

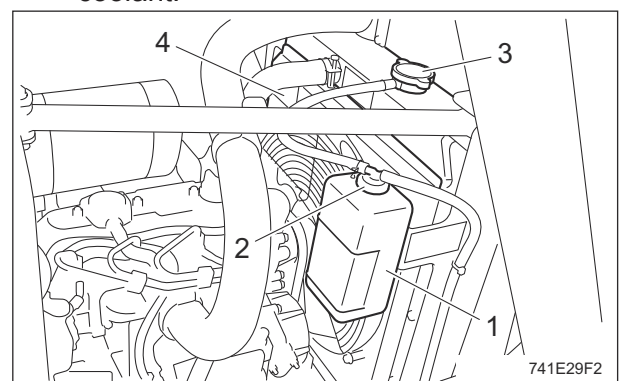

Replacement of Coolant_002

1	Reserve tank
2	Reserve tank cap
3	Radiator cap
4	Radiator

- [4] Remove the reserve tank.
- [5] Open the reserve tank cap, and then drain the coolant.

4. Install the reserve tank.
5. Clean the radiator with clean water (soft water) to remove any debris or rust.
6. Drain all water from the radiator.
7. Follow the steps below to fill with coolant. The coolant quantity including the reserve tank is 6.0 dm³ (6.0 L).
 - [1] Tighten the drain plug of radiator.
 - [2] Supply clean water (soft water) and antifreeze into the radiator up to the radiator cap opening.
 - [3] Close the radiator cap.
 - [4] Supply clean water (soft water) and antifreeze into the reserve tank up to the "FULL" mark.
 - [5] Close the reserve tank cap.
8. Start the engine, and then idle for a few minutes to bleed air.
9. Stop the engine, and then cool down the radiator.
10. Make sure that the coolant level in the reserve tank is between "FULL" and "LOW". If necessary, supply coolant.
11. Close the hood.

Main Vehicle

Replacement of Hydraulic Oil

⚠ Caution

Be careful with hot oil, which could cause burns if it contacts your skin.

⚠ Caution

Change oil after the hydraulic system has been sufficiently cooled down.

Important

When you change the hydraulic oil, be sure to drain it into a bowl and discard it in accordance with local laws and regulations.

Important

If the oil emulsifies or if it becomes even slightly less transparent, change the oil immediately.

Important

For the hydraulic oil to be used, consult Characteristics of Hydraulic Oil and use the oil whose characteristics are equivalent or superior to those specified there. Especially regarding kinematic viscosity and viscosity index, use of hydraulic oil whose figures are less than those of the specified hydraulic oil will cause a malfunction in the hydraulic circuit.

■ Characteristics of Hydraulic Oil

ISO Viscosity Grade		ISO VG46
Density	15 °C (59 °F)	0.873 g/cm ³ (0.0315 lb/in ³)
API Gravity		30.6
Flash Point (Open Cup)		230 °C (446 °F)
Pour Point		-30 °C (-22 °F)
Kinematic	40 °C (104 °F)	46 mm ² /s (46 cSt)
Viscosity	100 °C (212 °F)	7 mm ² /s (7 cSt)
Viscosity Index		109

■ Characteristics of Hydraulic Oil with conditions of use

Hydraulic oil of ISO viscosity grade VG68 can be used only if the following condition is met:

- The outside temperature must be 20 °C (68 °F) or more during engine operation.

ISO Viscosity Grade		ISO VG68
Density	15 °C (59 °F)	0.878 g/cm ³ (0.0318 lb/in ³)
API Gravity		29.7
Flash Point (Open Cup)		252 °C (486 °F)
Pour Point		-30 °C (-22 °F)
Kinematic	40 °C (104 °F)	68 mm ² /s (68 cSt)
Viscosity	100 °C (212 °F)	9 mm ² /s (9 cSt)
Viscosity Index		107

Note:

In Japan, "Shell Tellus S2M46 (ISO VG46)" and "Shell Tellus S2M68 (ISO VG68)" meet the characteristics described above.

Maintenance

However, in other countries, the specification of Shell Tellus S2M46 and Shell Tellus S2M68 can be below what is required.

Please check the product data sheet to ensure that it meets the requirements before using.

1. Follow the steps below to remove the old oil.

[1] Start and run the engine to warm up the oil.

[2] Lower the mower units on a level surface, and then stop the engine.

[3] Remove the drain plug of the hydraulic tank, and then drain the old oil into a container.

[4] Wind new sealing tape on the drain plug, and then attach it to the hydraulic tank.

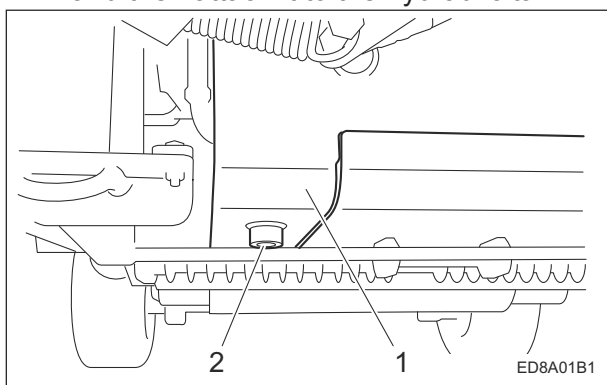

Replacement of Hydraulic Oil_001

1	Hydraulic tank
2	Drain plug

2. Follow the steps below to supply new oil.

[1] Open the center cover.

[2] Loosen the bushing with a wrench (accessory, #10076-) and remove the oil filler plug.

[3] Supply new hydraulic oil through the oil filling port until the oil level reaches the middle of the oil gauge on the hydraulic tank.

The hydraulic tank capacity is approximately 24.0 dm³ (24.0 L).

[4] Install the oil filler plug and tighten the bushing securely.

[5] Close the center cover.

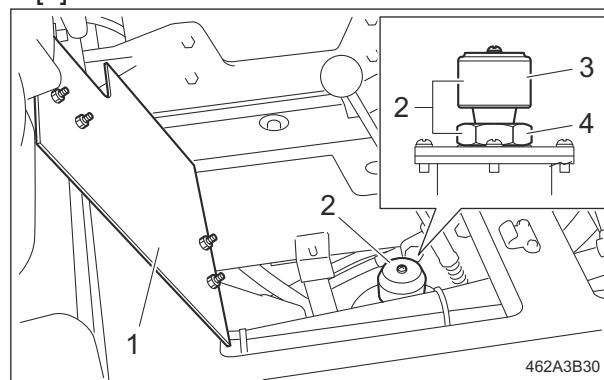

Replacement of Hydraulic Oil_002

1	Center cover
2	Oil filler plug
3	Air breather
4	Bushing

3. Start the engine, and then repeat the steps below a few times.

- Raise and lower the mower units.
- Turn the steering wheel left and right.
- Move forward and reverse.

4. Lower the mower units and maintain that position on a level surface, and then check to see if the oil level is at the middle of the oil gauge.

If the hydraulic oil level is low, supply oil again until it reaches the specified level.

5. Check underneath the machine for oil leakage.

Replacement of Hydraulic Oil Filter

1	Filter cartridge
---	------------------

■ Replacement of Hydraulic Oil Line Filter

Caution

Be careful with hot oil, which could cause burns if it contacts your skin.

Caution

Change filter after the hydraulic system has been sufficiently cooled down.

Important

When replacing the hydraulic oil filter, be sure to drain the oil into a container and discard it in accordance with local laws and regulations.

Important

If the hydraulic oil emulsifies or if it becomes even slightly less transparent, change the oil immediately.

Important

Use hydraulic oil whose specification meets the requirements.

1. Lower the mower units on a level surface, and then stop the engine.
2. Remove the old filter cartridge.
3. Lightly coat the packing of the new filter cartridge with hydraulic oil, and then install the cartridge.
4. Firmly tighten the filter cartridge by hand so that the packing contacts the mounting surface. Then, tighten it an additional 1/2 turn.

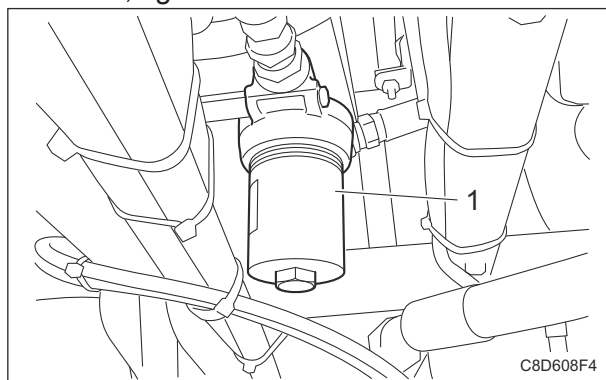

Replacement of Hydraulic Oil Line Filter_001

5. Supply hydraulic oil until it reaches the specified level.
"Supply of Hydraulic Oil" (Page 6-10)
6. Start the engine, and then after the hydraulic oil has warmed up, stop the engine.
7. Check underneath the machine for hydraulic oil leakage.

Maintenance

■ Replacement of Hydraulic Oil Suction Filter

⚠ Caution

Be careful with hot oil, which could cause burns if it contacts your skin.

⚠ Caution

Change filter after the hydraulic system has been sufficiently cooled down.

Important

When replacing the hydraulic oil filter, be sure to drain the oil into a container and discard it in accordance with local laws and regulations.

Important

If the hydraulic oil emulsifies or if it becomes even slightly less transparent, change the oil immediately.

Important

Use hydraulic oil whose specification meets the requirements.

Important

Replace the intake port packing with a new one.

Important

Be careful that dust does not fall into the tank when changing the filter. Otherwise, it will damage the hydraulic system.

1. Lower the mower units on a level surface, and then stop the engine.
2. Remove the center cover.
3. Remove bolts, spring washers and washers (- #10107), and then remove the intake hose joint fitting.
4. Remove the old suction filter and intake port packing.
5. Remove all of the old liquid gasket from the hydraulic tank.

6. Remove all of the old liquid gasket and the intake port packing from the intake hose joint fitting.
7. Wash and clean the intake hose joint fitting.
8. Apply liquid gasket to the new intake port packing and then install it to the intake hose joint fitting.
9. Install the new suction filter to the intake hose joint fitting.
10. Install the intake hose joint fitting.

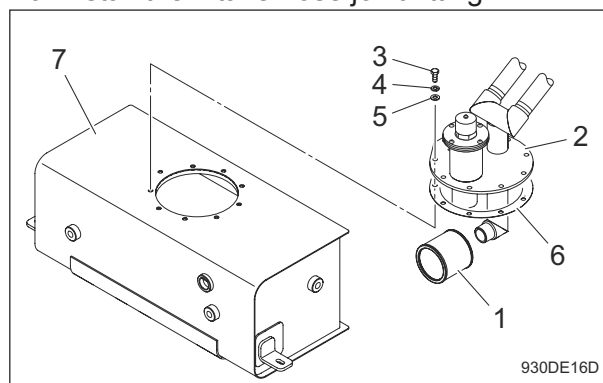

Replacement of Hydraulic Oil Suction Filter_001

1	Suction filter
2	Intake hose joint fitting
3	Bolt
4	Spring washer
5	Washer (- #10107)
6	Intake port packing
7	Hydraulic tank

11. Supply hydraulic oil until it reaches the specified level.
"Supply of Hydraulic Oil" (Page 6-10)
12. Start the engine, and stop it after hydraulic oil has been warmed up.
13. Check underneath the machine for hydraulic oil leakage.
14. Install the center cover.

Replacement of Air Breather Element

Caution

Be careful with hot oil, which could cause burns if it contacts your skin.

1. Lower the mower units on a level surface, and then stop the engine.
2. Loosen the air breather screw and remove the seal washer.

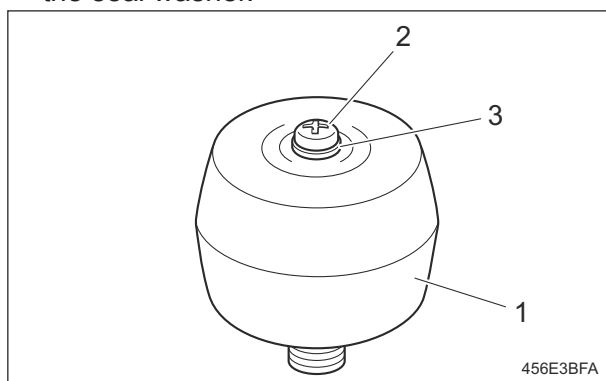

Replacement of Air Breather Element_001

1	Air breather
2	Screw
3	Seal washer

3. Remove the top cover of the air breather.
4. Remove the old element.

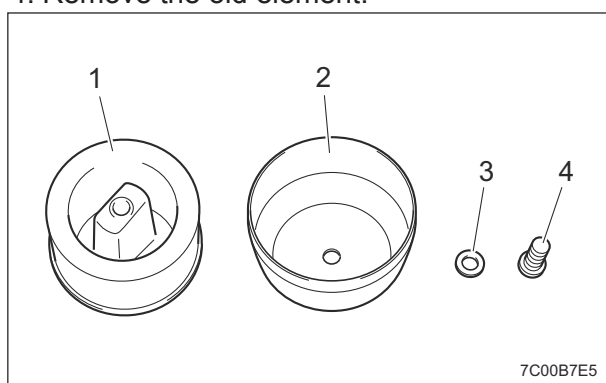

Replacement of Air Breather Element_002

1	Element
2	Top cover
3	Seal washer
4	Screw

5. Install the new element.

Important

If the seal washer is damaged, replace it with a new one.

6. Install the top cover of the air breather.

7. Install the seal washer and tighten the screw.

Replacement of Tires

■ Replacement of Front Tires

1. Removing front tires

Follow the steps below to remove the front tires:

- [1] Loosen the bolts.

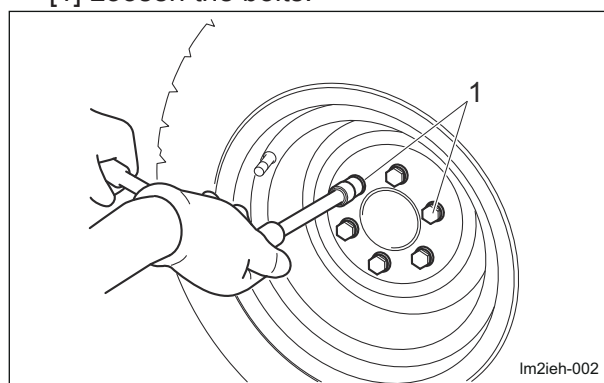

Replacement of Front Tires_001

1	Heat-treated bolt
---	-------------------

- [2] Securely place the jack beneath the jack-up point of the front left/right frame area, and then raise it until the tire lifts off the ground.

"Jack-Up Points" (Page 6-2)

- [3] Remove the bolts.

- [4] Remove the tire from the wheel mounting seat.

2. Installing front tires

Important

Tighten the bolts in the tightening order (diagonally).

Important

Tighten the wheel mounting bolts on the specified torque by using a torque wrench.

For installing the front tires, reverse the removing procedure.

Maintenance

■ Replacement of Rear Tires

1. Removing rear tires

Follow the steps below to remove the rear tires:

[1] Loosen the bolts.

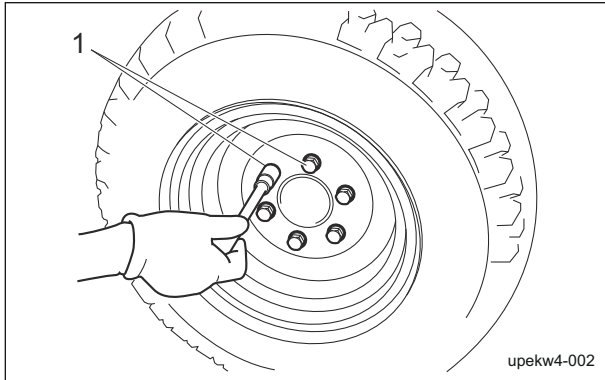

Replacement of Rear Tires_001

1	Bolt
---	------

[2] Securely place the jack beneath the jack-up point of the rear frame area, and then raise it until the tire lifts off the ground.

"Jack-Up Points" (Page 6-2)

[3] Remove the bolts.

[4] Remove the tire from the wheel mounting seat.

2. Installing rear tires

Important

Tighten the bolts in the tightening order (diagonally).

Important

Tighten the wheel mounting bolts on the specified torque by using a torque wrench.

For installing the rear tires, reverse the removing procedure.

Storage

Long-Term Storage

Follow the instructions below for long-term storage of the machine.

1. Cleaning

- Remove dirt, grass clippings, oil stains etc. completely from the main vehicle and engine.

2. Replacing oil

- Inspect and replace the engine oil, hydraulic oil and element.

3. Greasing and lubricating

- Supply oil and apply grease to appropriate parts.

4. Battery

- Remove the negative battery wire.

5. Fuel

- Remove the fuel from the fuel tank.

6. Tire pneumatic pressure

- Set the tire air pressure slightly higher than normal, and then place the machine on a board to avoid humidity.

7. Mower units

- When storing this machine, lower all the mower units unless a positive mechanical lock is provided.

8. Storage location

- Cover the machine and store it in a dry place where it will not be exposed to rain.

Precautions for Repair Page 7-2

Adjustment Page 7-2

Adjustment of Brake Page 7-2

Adjustment of Parking Brake Page 7-3

Adjustment of The Neutral Position
of The Piston Pump Page 7-4

Replacement Page 7-5

Replacement of Fuse Page 7-5

TowingPage 7-6

Towing the Machine in an
EmergencyPage 7-6



Repair

Precautions for Repair

Warning

The chapter "Repair" in this manual describes practical measures which should be performed by a mechanic with expertise. The owner should instruct the mechanic with expertise to perform repair service for this machine.

Caution

First, learn well the operations you plan to perform.

Important

Use tools appropriate for each operation.

Important

Use Baroness genuine parts for replacement and accessories. Our product warranty may be void if you use non-genuine parts for replacement or accessories.

Adjustment

Adjustment of Brake

Caution

If the brake wire is cut, the machine will be unable to stop. This would be extremely dangerous. If the brake wire is cracked or damaged, replace it with a new one immediately.

Caution

If the brake is not sufficiently effective, adjust the brake wire.

Caution

It may result in an unexpected accident if the left and right brakes are not equally effective.

Important

Make sure that the brake is effective and that it is not applied any longer when you release it.

Adjust the brake whenever there is any abnormality.

Important

Adjust to reduce the play in the brake lever as much as possible so that the brake does not drag when the lever is released.

Adjust the brake so that it is in the following conditions.

- Brake applies when the brake pedal is depressed.
 - The left and right brakes are equally effective.
 - Brake does not apply any longer when the brake pedal is released.
1. Adjust the brake by tightening the brake wire adjustment bolt.
 - If there is too much play in the brake lever, the braking force is reduced and the brake pedal feel become light.
 - If there is too little play in the brake lever, the braking force is increased and the brake pedal feel become heavy.

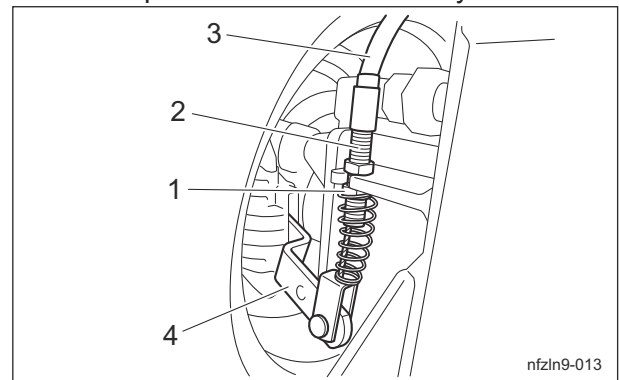

Adjustment of Brake_001

1	Lock nut
2	Adjustment bolt
3	Brake wire
4	Brake lever

2. After completing the adjustment of the brake, start the engine and drive to check the following.

- Make sure that heat is not generated in the brake area.
- Make sure that the brake applies when the brake pedal is depressed.
- Make sure that the left and right brakes are equally effective when the brake pedal is depressed.

If the left and right brakes are not equally effective, make fine adjustments with the adjustment bolt on the brake wire.

Break-In of Brakes

If the brake shoes or brake pads are worn, replace them with new ones.

Immediately after replacement, drive to break in the brakes if the effectiveness of the brakes is low.

While driving, lightly operate the brakes to break in the contact areas.

Adjustment of Parking Brake

⚠ Caution

If the brake wire is cut, the machine will be unable to stop. This would be extremely dangerous.

If the brake wire is cracked or damaged, replace it with a new one immediately.

⚠ Caution

If the brake is not sufficiently effective, adjust the brake wire.

Important

Make sure that the brake is effective and that it is not applied any longer when you release it.

Adjust the parking brake system whenever there is any abnormality.

Adjust the parking brake so that it is in the following conditions.

- Brake applies when the parking brake lever is pulled.
- Brake is not applied any longer when the parking brake lever is released.

1. Apply the parking brake.

2. Check the position of the notch of the parking brake.

It is appropriate when the latch of the parking brake lock lever catches on a position at arrow A (third notch from the top).

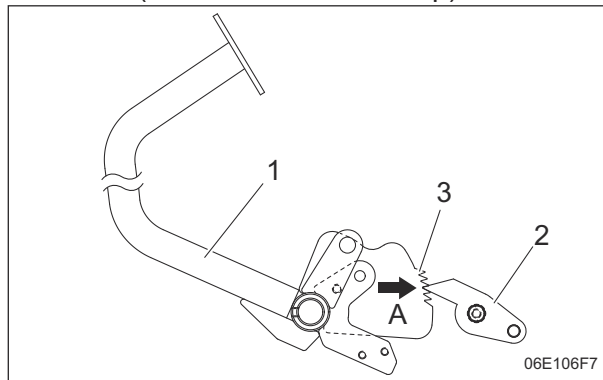

Adjustment of Parking Brake_001

1	Brake pedal
2	Latch
3	Notch

3. If the position of the latch of the parking brake lock lever is not appropriate, adjust the adjustment bolt inside of the tire.

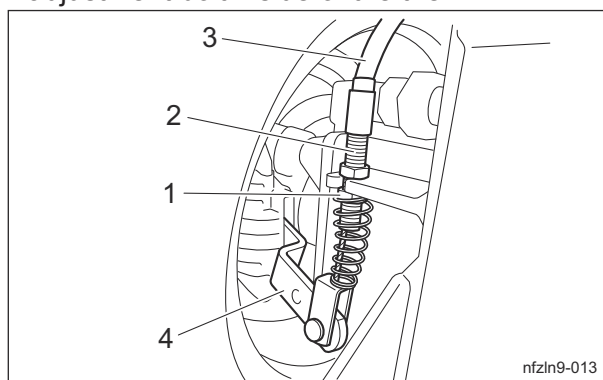

Adjustment of Parking Brake_002

1	Lock nut
2	Adjustment bolt
3	Brake wire
4	Brake lever

Repair

Adjustment of The Neutral Position of The Piston Pump

⚠ Caution

Make sure not to touch rotating tires.

⚠ Caution

When adjusting the neutral position, pay close attention to abrupt start of the machine. Place the jacks beneath the jack-up points, and then lift the machine until all the tires get off the ground.

If the machine moves forward or backward while the traveling pedals are released, they are not set to the neutral position.

Follow the steps below to make adjustments.

1. Stop the engine.
2. Place the jacks beneath the jack-up points, and then lift the machine off the ground. "Jack-Up Points" (Page 6-2)
3. Make sure that no tires get contact with the jack stand.
4. Start the engine, and rev it up to the maximum rpm.
5. Adjust the neutral position.
 - [1] Loosen the lock nuts.
 - [2] Rotate the traction adjusting cam slowly until all wheels stop.
 - If the tires move in the direction of forward travel, rotate the traction adjusting cam clockwise.
 - If the tires move in the direction of backward travel, rotate the traction adjusting cam counterclockwise.
 Find the position where all tires stop, and then, while holding the traction adjusting cam in place, secure it with the lock nut.

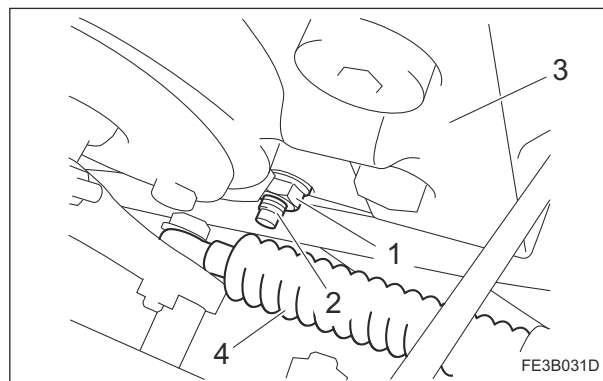

Adjustment of The Neutral Position of The Piston Pump_001

1	Lock nut
2	Traction adjusting cam
3	Piston pump
4	Push-pull cable

6. Check that the tires do not move.

Replacement

Replacement of Fuse

Important

When performing maintenance on the electrical system, be sure to remove the negative battery wire.

Important

If a fuse blows, a short may have occurred within the electrical circuit. Check for the cause, such as faulty terminal connections, damaged wiring or terminals, or incorrect wiring.

Important

For fuse replacement, clean the fuse mounting area with use of compressed air before mounting the fuse.

Fuse Box

The fuse box includes spare fuses and tools.

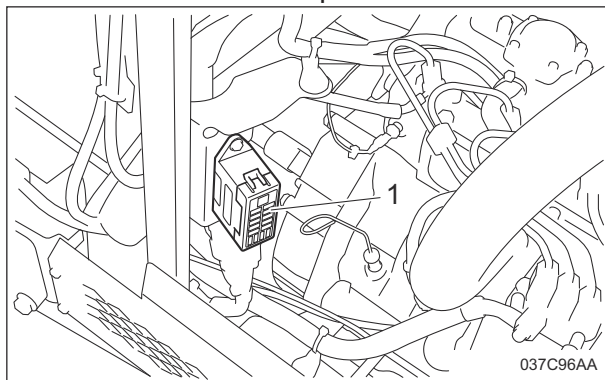

Fuse Box_001

1 Fuse box

The fuses are standard mini fuses for automobiles. Replace them with fuses of the rated capacity.

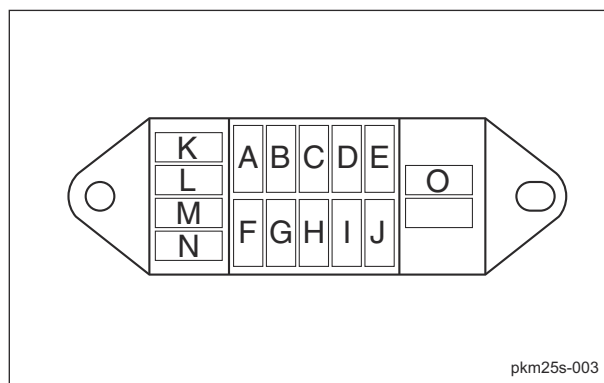

pkm25s-003

Fuse Box_002

A	5 A	Glow lamp timer
B	5 A	Glow lamp
C	5 A	Fuel pump
D	5 A	Charge lamp, oil pressure (engine oil pressure) lamp, water temperature gauge, buzzer, hour meter, fuel gauge
E	15 A	Reel normal rotation solenoid, reel reverse rotation solenoid
F	15 A	Light, USB charger
G	5 A	Glow lamp timer
H	5 A	Alternator (IG)
I	5 A	Pproximity switch relay, #2 proximity switch, fuel stop solenoid relay (when back lapping), relay box
J	5 A	Starter relay, seat switch relay, fuel stop solenoid relay, reel rotation ON relay, lower lever relay, forward/reverse relay, unit down proximity switch, pump neutral proximity switch, brake proximity switch
K	5 A	Spare
L	5 A	Spare
M	15 A	Spare
N	15 A	Spare
O		Tool

Repair

Fuse

(#10208-)

Two fuse wirings are located inside the right side cover.

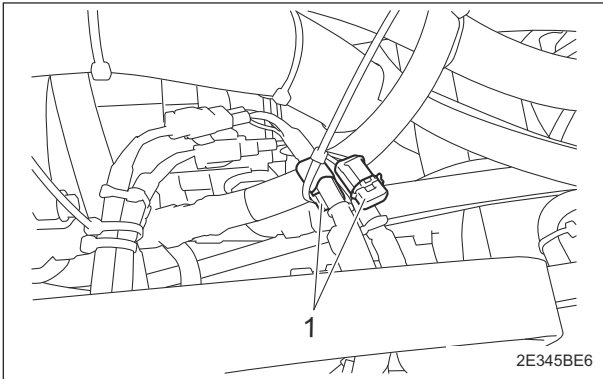

Fuse_001

1	Fuse wiring
---	-------------

Fuses are mini blade.

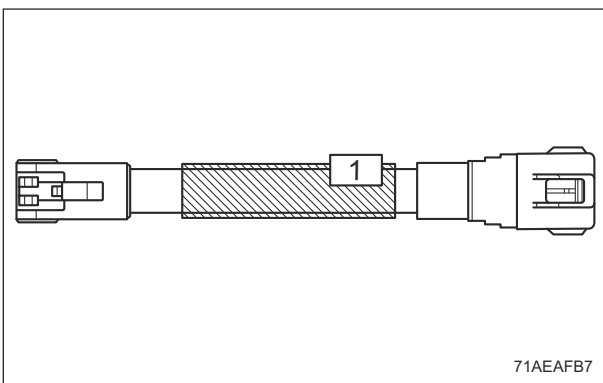

Fuse_002

1	5 A	Rotation SOL
---	-----	--------------

Fusible Link

Fuse capacities of the fusible links are 30 A and 50 A.

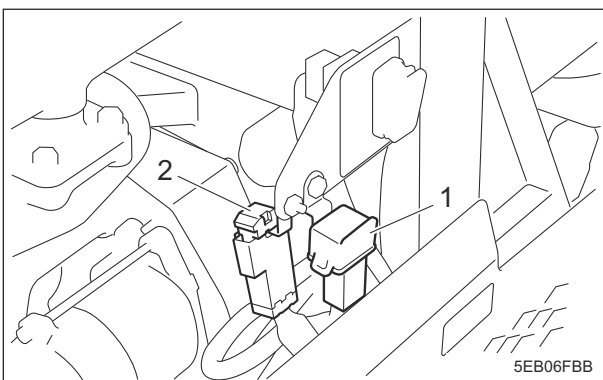

Fusible Link_001

1	Fusible link (30 A)
2	Fusible link (50 A)

Towing

Towing the Machine in an Emergency

If the machine does not travel due to engine trouble, etc., you can move it in the following way.

Caution

Before restarting the engine, be sure to close the bypass.

Important

Do not touch the unload valve except when towing the machine.

Important

When towing the machine, obey the following restrictions.

Obey the speed and the time restrictions to prevent damaging the pump or motor.

- Speed: Do not travel at a speed more than 3.0 km/h.
- Time: Do not tow the machine for more than 3 minutes.

When towing the machine for more than 3 minutes, start the engine and circulate the hydraulic oil in the hydraulic circuit.

Therefore, do not tow the machine until restart the engine after completed repairs.

Important

Do not loosen the unload valve three turns or more.

1. Stop the engine.
"Procedure to Stop Engine" (Page 5-13)
2. Apply the parking brake.
3. Chock the wheels.

4. Secure the machine with ropes.
- Front part of the machine: Use tow hooks on the left and right side of the frame.

Left side

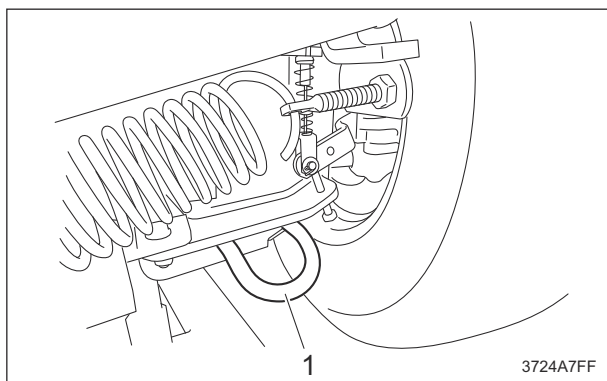

Towing the Machine in an Emergency_001

1 Tow hook

Right side

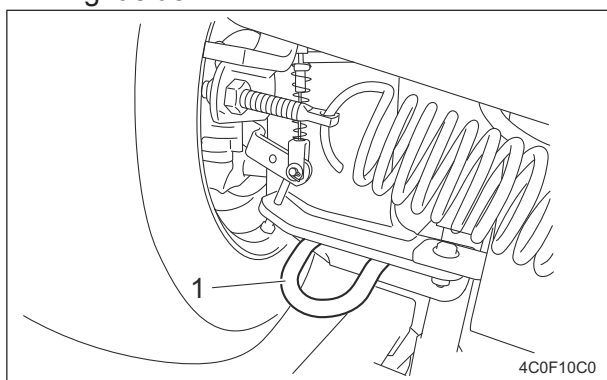

Towing the Machine in an Emergency_002

1 Tow hook

- Rear part of the machine: Use tow hook on the frame.

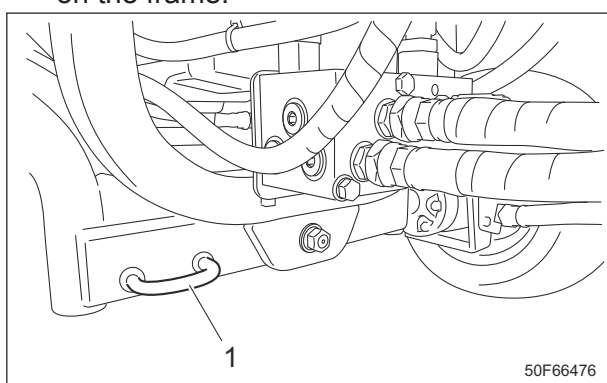

Towing the Machine in an Emergency_003

1 Tow hook

5. Open the underseat cover.
"Procedure to Open/Close Underseat Cover"
(Page 5-3)

6. Open the bypass.
Rotate the unload valve 1 to 1.5 turns counterclockwise to set it to the "Unload" position.

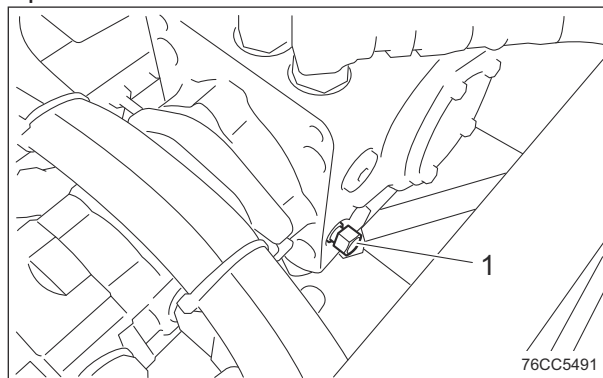

Towing the Machine in an Emergency_004

1 Unload valve

7. Close the underseat cover.
8. Remove the wheel stoppers.
9. Release the parking brake.

Warning

While towing, always keep your foot on the brake pedal to make sure you can depress it at any time to stop.

10. Tow the machine slowly.
11. After towing is completed, close the bypass.
Rotate the unload valve 1 to 1.5 turns clockwise to set it to the "Onload" position.

Appended Table

Tightening TorquesPage 8-2
 Standard Tightening TorquesPage 8-2
 Principal Tightening Torques Page 8-5

Daily Check List Page 8-7

Maintenance Schedule Page 8-8

List of Adjusted Values Page 8-13

Appended Table

Appended Table

Tightening Torques

Important

Refer to the Tightening Torque table.
Note that the Baroness product warranty may not apply to defects caused by incorrect or overtorque tightening, etc.

Standard Tightening Torques

Bolts and Nuts



Important

A number of bolts are used in each part of this machine.
Be sure to re-tighten the bolts and nuts, because they may be loosened at the earlier stage of the use.

- As to the bolts and nuts without any special instruction, tighten them in appropriate tightening torque with proper tool.
Too much tightening may cause the looseness or damage of the screw.
- The strength of tightening is determined by types of screws, strength, the friction of thread face or base face and others.
The table below is for the galvanized or parkerized bolts.
In case that the strength of internal thread is weak, it is not applied.
- Do not use rusty or sand attached "screw."
Otherwise, it may cause insufficient tightening even if you apply the specified tightening torque.
The friction of the screw face becomes higher and the tightening torque is canceled out by the friction, therefore sufficient tightening cannot be applied.
- If "screw" is wet by water or oil, do not tighten it with normal tightening torque.
If the screw is wet, the torque coefficient will get smaller and it may result in too much tightening.
Too much tightening may cause looseness by the screw stretched or result in damage.
- Do not use a bolt experienced too much burden.
- Using the impact wrench requires the skill.
Do exercise as much as possible for steady tightening.

Appended Table

Nominal diameter	General bolt		
	Strength classification 4.8		
	 tib3yb-001		
	N-m	kgf-cm	lb-in
M5	3 - 5	30.59 - 50.99	26.55 - 44.26
M6	7 - 9	71.38 - 91.77	61.96 - 79.66
M8	14 - 19	142.76 - 193.74	123.91 - 168.17
M10	29 - 38	295.71 - 387.49	256.68 - 336.34
M12	52 - 67	530.24 - 683.20	460.25 - 593.02
M14	70 - 94	713.79 - 958.52	619.57 - 831.99
M16	88 - 112	897.34 - 1142.06	778.89 - 991.31
M18	116 - 144	1,182.85 - 1,468.37	1,026.72 - 1,274.54
M20	147 - 183	1,498.96 - 1,866.05	1,301.10 - 1,619.73
M22	295	3,008.12	2,611.05
M24	370	3,772.89	3,274.87
M27	550	5,608.35	4,868.05
M30	740	7,545.78	6,549.74

Nominal diameter	Heat-treated bolt					
	Strength classification 8.8			Strength classification 10.9		
	 tib3yb-002			 tib3yb-003		
	N-m	kgf-cm	lb-in	N-m	kgf-cm	lb-in
M5	5 - 7	50.99 - 71.38	44.26 - 61.96	7 - 10	71.38 - 101.97	61.96 - 88.51
M6	8 - 11	81.58 - 112.17	70.81 - 97.36	14 - 18	142.76 - 183.55	123.91 - 159.32
M8	23 - 29	234.53 - 295.71	203.57 - 256.68	28 - 38	285.52 - 387.49	247.83 - 336.34
M10	45 - 57	458.87 - 581.23	398.30 - 504.51	58 - 76	591.43 - 774.97	513.36 - 672.68
M12	67 - 85	683.20 - 866.75	593.02 - 752.34	104 - 134	1,060.49 - 1,366.40	920.50 - 1186.03
M14	106 - 134	1,080.88 - 1,366.40	938.21 - 1,186.03	140 - 188	1,427.58 - 1,917.04	1,239.14 - 1,663.99
M16	152 - 188	1,549.94 - 1,917.04	1,345.35 - 1,663.99	210 - 260	2,141.37 - 2,651.22	1,858.71 - 2,301.26
M18	200 - 240	2,039.40 - 2,447.28	1,770.20 - 2,124.24	280 - 340	2,855.16 - 3,466.98	2,478.28 - 3,009.34
M20	245 - 295	2,498.27 - 3,008.12	2,168.50 - 2,611.05	370 - 450	3,772.89 - 4,588.65	3,274.87 - 3,982.95
M22	-	-	-	530	5,404.41	4,691.03
M24	-	-	-	670	6,831.99	5,930.17
M27	-	-	-	1,000	10,197.00	8,851.00
M30	-	-	-	1,340	13,663.98	11,860.34

Note:

The same values are applied to "fine screw thread."

Appended Table

Hydraulic Hose

The tightening torques for union joints and union adaptors with parallel pipe threads (G, PF) are shown in the table below.

A union joint or adaptor will not become loose or leak as long as it is tightened by the specified torque.

If fluid leaks from the sealed portion, do not attempt to tighten the union joint or adaptor forcibly.

Examine whether any foreign matter or scratches are present on the seat surface.

Tightening a union joint or adaptor forcibly could damage the connection of the joints.

When tightening a union joint or adaptor, use a torque wrench where possible and firmly tighten it by an appropriate torque.

Nominal diameter of the hose size	Nominal diameter of the parallel pipe threads (G, PF)	Tightening torque		
		N-m	kgf-cm	lb-in
6	1/4	25	254.93	221.28
9	3/8	50	509.85	442.55
12	1/2	60	611.82	531.06
15	3/4	120	1,223.64	1,062.12
19	3/4	120	1,223.64	1,062.12
25	1	140	1,427.58	1,239.14
32	1-1/4	170	1,733.49	1,504.67
38	1-1/2	210	2,141.37	1,858.71
50	2	250	2,549.25	2,212.75

Fittings with Parallel Threads (O-Ring Seal Type)

The tightening torques for fittings with parallel threads (O-ring seal method) are shown in the table below.

Tightening the fitting forcibly with a spanner or other such tool to secure it to a set position could damage the fitting, its washers, and other parts.

When tightening an adjustable elbow, use a torque wrench where possible and firmly tighten it by an appropriate torque.

Nominal diameter of thread	Tightening torque		
	N-m	kgf-cm	lb-in.
1/4	34.32 - 49.03	349.96 – 499.96	303.77 – 433.96
3/8	68.65 - 78.45	700.02 – 799.95	607.62 – 694.36
1/2	98.07 - 117.68	1,000.02 – 1,199.98	868.02 – 1,041.59
3/4	147.10 - 176.52	1,499.98 – 1,799.97	1,301.98 – 1,562.38
1	245.17 - 274.59	2,500.00 – 2,799.99	2,170.00 – 2,430.40
1-1/4	294.20	2,999.96	2,603.96
1-1/2	294.20	2,999.96	2,603.96
2	392.27	3,999.98	3,471.98

Appended Table

Principal Tightening Torques

Tightening Torque by Model

LM351

Tighten the following bolts and nuts to the torque specified in the table.

For thread locking adhesive, apply a medium strength thread locker (ThreeBond 1322 anaerobic adhesive or equivalent).

Location		Code	Part name	Tightening torque			Thread locking adhesive
				N-m	kgf-cm	lb-in	
Front wheel	Motor	K0010120902	Bolt, heat-treated M12-90	104 - 134	1,060.49 - 1,366.40	920.50 - 1,186.03	-
	Wheel mounting base	-	Slotted nut attached to hydraulic motor 1-20UNEF	280 - 300	2,855.16 - 3,059.10	2,478.28 - 2,655.30	-
	Wheel	K0011120352	Bolt, heat-treated M12-35P1.5	110	1121.67	973.61	-
Rear wheel	Motor	K0013120702	Bolt, heat-treated M12-70	104 - 134	1,060.49 - 1,366.40	920.50 - 1,186.03	-
	Wheel mounting base	-	Slotted nut attached to hydraulic motor 1-20UNEF	280 - 300	2,855.16 - 3,059.10	2,478.28 - 2,655.30	-
	Wheel	K0011120352	Bolt, heat-treated M12-35P1.5	110	1121.67	973.61	-
Tie rod		(K1610000020)	Slotted nut (Tie rod end right Assy)	45	458.87	398.30	-
		(K1611000020)	Slotted nut (Tie rod end left Assy)	45	458.87	398.30	-
Kingpin stopper	K0000100252	Bolt, M10-25	29 - 38	295.71 - 387.49	256.68 - 336.34	-	
Universal joint	K001A100401	Bolt, w/ hexagon hole, M10-40	62 - 72	632.21 - 734.18	548.76 - 637.27	○	
	K0011100252	Bolt, heat-treated M10-25P1.25	58 - 76	591.43 - 774.97	513.36 - 672.68	-	
Engine	K0017100252	Bolt, small, heat-treated M10-25P1.25	45 - 57	458.87 - 581.23	398.30 - 504.51	-	
Electric components for engine	-	Starter B terminal (M8)	5.9 - 11.7	60.16 - 119.30	52.22 - 103.56	-	

Appended Table

Location	Code	Part name	Tightening torque			Thread locking adhesive
			N-m	kgf-cm	lb-in	
Electric components for engine	-	Alternator B terminal (M6)	5.9 - 9.8	60.16 - 99.93	52.22 - 86.74	-
	-	Glow plug connection terminal nut (M4)	1.0 - 1.8	10.20 - 18.35	8.85 - 15.93	-
Terminal relay	K3680000030	M3.5 Screw (accessories)	0.78 - 1.18	7.95 - 12.03	6.90 - 10.44	-
Cross-valve	K0013101252	Bolt, heat-treated M10-125	29 - 38	295.71 - 387.49	256.68 - 336.34	-
Brake pedal bracket	K0013080701	Bolt, HT M8-70	28 - 38	285.52 - 387.49	247.83 - 336.34	○
Proximity switch NO V-in	K0000050202	Bolt, M5-20	2.5	25.49	22.13	-
	K0100050002	Nut, M5	2.5	25.49	22.13	-
Proximity switch NC V-in	K0000050202	Bolt, M5-20	2.5	25.49	22.13	-
ROPS	K0010120402	Bolt, heat-treated M12-40	104 - 134	1,060.49 - 1,366.40	920.50 - 1,186.03	-
Piston pump	K0013140502	Bolt, HT M14-50	140 - 188	1,427.58 - 1,917.04	1,239.14 - 1,663.99	-
Battery terminal	K3610000230	Wire, battery (+) 1250	6	61.18	53.11	-
	K3611000420	Wire, to earth 1000	6	61.18	53.11	-

Daily Check List

- . . . Inspect, adjust, supply, clean (first time)
- . . . Inspect, adjust, supply, clean
- ▲ . . . Replace (first time)
- △ . . . Replace

Maintenance Item		Before Work	After Work	Remarks
Engine	*1	Check engine oil	○	
	*1	Check fuel	○	
		Check fuel filter	○	
	*1	Check coolant	○	
	*1	Check air cleaner	○	
		Check radiator cover	○	
		Check radiator	○	
		Check engine area	○	
		Clean radiator cover		○
	*1	Clean radiator		○
	Clean engine area		○	
Main vehicle		Check hydraulic oil	○	
		Check tire	○	
	*2	Check battery	○	
		Check oil cooler	○	
		Check cover	○	
		Check wire	○	
		Check brake pedal	○	
		Check parking brake lever	○	
		Check traveling pedal	○	
		Check pedal stopper		
		Check oil or water leaks	○	
		Check machine exterior	○	
		Check bolts and nuts	○	
		Check hour meter	○	
		Check water temperature gauge	○	
		Check fuel gauge	○	
		Check pilot lamp	○	
		Check safety mechanisms	○	
		Check steering wheel	○	
		Check lighting	○	
	Clean oil cooler		○	
	Clean machine exterior		○	

- *1: Refer to the Engine's Owner's Manual.
- *2: Refer to the Battery's Owner's Manual.

Appended Table

Maintenance Schedule

LM351

● . . . Inspect, adjust, supply, clean (first time)

○ . . . Inspect, adjust, supply, clean

▲ . . . Replace (first time)

△ . . . Replace

Maintenance Item		Before Work	After Work	Every Week	Every 50 hrs.	Every 100 hrs.	Every 150 hrs.	Every 200 hrs.	Every 250 hrs.	Every 400 hrs.	Every 500 hrs.	Every 800 hrs.	Every 1500 hrs.	Every 3000 hrs.	every month	every 3 months	every 6 months	Every year	Every 2 years	Every 4 years	When Required	Remarks	
Engine	*3		○	○																		Open valve every week or daily in dusty conditions	
	*2.*3				○																		
		Clean fuel filter				○																	
		Check water separator				○																	
		Draining of water separator				○																	
	*2.*3	Clean air cleaner element				○																	Air cleaner should be cleaned more often in dusty conditions than in normal conditions
	*3	Check of fan belt tightness				○																	
	*2.*3	Check intake air line (air cleaner hose)						○															

Appended Table

Maintenance Item		Before Work	After Work	Every Week	Every 50 hrs.	Every 100 hrs.	Every 150 hrs.	Every 200 hrs.	Every 250 hrs.	Every 400 hrs.	Every 500 hrs.	Every 800 hrs.	Every 1500 hrs.	Every 3000 hrs.	every month	every 3 months	every 6 months	Every year	Every 2 years	Every 4 years	When Required	Remarks	
Engine	*3	Check radiator hoses and clamp bands						○									○					Check every 200 hours or every 6 month whichever comes earlier	
		Clean water separator							○														
	*1.*3	Clean fuel tank interior									○												
	*1.*3	Clean water jacket (radiator interior)									○												
	*1.*3	Check valve clearance										○											
	*1.*2.* 3	Check of fuel injection nozzle injection pressure											○										
	*1.*2.* 3	Check of injection pump												○									
	*3	Change engine oil				▲	△												△				Initial 50 hours, thereafter every 100 hours or every year whichever comes earlier

Appended Table

Appended Table

Maintenance Item		Before Work	After Work	Every Week	Every 50 hrs.	Every 100 hrs.	Every 150 hrs.	Every 200 hrs.	Every 250 hrs.	Every 400 hrs.	Every 500 hrs.	Every 800 hrs.	Every 1500 hrs.	Every 3000 hrs.	every month	every 3 months	every 6 months	Every year	Every 2 years	Every 4 years	When Required	Remarks	
Engine	*3	Replace engine oil filter cartridge			▲			△										△				Initial 50 hours, thereafter every 200 hours or every year whichever comes earlier	
		Replace fuel filter cartridge								△													
	*3	Replace fan belt									△									△		Replace every 500 hours or 2 years whichever comes earlier	
	*2.*3	Replace air cleaner element																△				Replace every 6 cleanings or every year whichever comes earlier	
	*3	Change radiator coolant (L.L.C.)																		△			
	*3	Replace radiator hoses and clamp bands																		△			
	*1.*2.*3	Replace fuel hoses and clamp bands																		△			

Appended Table

Maintenance Item			Before Work	After Work	Every Week	Every 50 hrs.	Every 100 hrs.	Every 150 hrs.	Every 200 hrs.	Every 250 hrs.	Every 400 hrs.	Every 500 hrs.	Every 800 hrs.	Every 1500 hrs.	Every 3000 hrs.	every month	every 3 months	every 6 months	Every year	Every 2 years	Every 4 years	When Required	Remarks	
Engine	*1.*2.* 3	Replace intake air line (air cleaner hose) and clamp bands																			△			
Main vehicle		Check hydraulic hose (Moving part)	○																					
		Grease and lubricate				○												○						Maintenance schedules differ according to greasing points
		Check electrical wiring				●	○																	
		Check wheel mounting bolts				●	○																	
		Check hydraulic hose (Fixed part) condition					○											○						Check every 100 hours or every month whichever comes earlier
		Grease hydraulic motor shaft of the mower unit								○														
		Adjust lift arm spring																					○	
		Replace hydraulic oil					▲						△											

Appended Table

Appended Table

Maintenance Item		Before Work	After Work	Every Week	Every 50 hrs.	Every 100 hrs.	Every 150 hrs.	Every 200 hrs.	Every 250 hrs.	Every 400 hrs.	Every 500 hrs.	Every 800 hrs.	Every 1500 hrs.	Every 3000 hrs.	every month	every 3 months	every 6 months	Every year	Every 2 years	Every 4 years	When Required	Remarks	
Main vehicle	Replace hydraulic suction filter					▲					△												
	Replace hydraulic line filter					▲					△												
	Replace air breather element					▲					△												
	*4 Replace battery																			△			
	*1 Replace hydraulic hoses (Moving part)																			△			
	*1.*5 Replace hydraulic hoses (Moving part) relating to steering																			△			
	*1 Replace hydraulic hoses (Fixed part)																				△		
	*1 Replace brake cables																					△	
	*1 Replace traveling cable																					△	
	Replace throttle wire																					△	
	*1 Replace brake pads																					△	

- *1: Consult your local Baroness Dealer or local KUBOTA Dealer for this service.
- The items above (*2 marked) are registered as emission related critical parts by KUBOTA in the U.S. EPA nonroad emission regulation.
As the engine owner, you are responsible for the performance of the required maintenance on the engine according to the above instruction.
Please see the Engine's Warranty Statement in detail.
- *3: Refer to the Engine's Owner's Manual.

- *4: Refer to the Battery's Owner's Manual.
- *5: Be sure to replace hydraulic hoses for steering cylinder and hydraulic hoses for hydraulic motor of wheel relating to steering every two years.
- The values for consumables are not guaranteed.

List of Adjusted Values

	10 mm (0.39 in)	Slack when applying 98 N (10 kgf) force to the belt at the middle point
Fan belt	Adjustment: 200 - 300 N (20.39 - 30.59 kgf) Replacement: 267 - 361 N (27.23 - 36.81 kgf)	Measurement of belt tension by using a sonic type tension meter

Appended Table

Daily Check Records Page 9-2

Maintenance RecordsPage 9-5

Records

Records

Daily Check Records

LM351

Use this table freely for your records of the daily check.

Model								Serial Number			
Items											
Engine	Check engine oil										
	Check fuel										
	Check fuel filter										
	Check coolant										
	Check air cleaner										
	Check radiator cover										
	Check radiator										
	Check engine area										
	Clean radiator cover										
	Clean radiator										
	Clean engine area										

Items										
Main vehicle	Check hydraulic oil									
	Check tire									
	Check battery									
	Check oil cooler									
	Check cover									
	Check wire									
	Check brake pedal									
	Check parking brake lever									
	Check traveling pedal									
	Check pedal stopper									
	Check oil or water leaks									
	Check machine exterior									
	Check bolts and nuts									
	Check hour meter									

Records

Records

Items											
Main vehicle	Check water temperature gauge										
	Check fuel gauge										
	Check pilot lamp										
	Check safety mechanisms										
	Check steering wheel										
	Check lighting										
	Clean oil cooler										
	Clean machine exterior										

Maintenance Records

LM351
Use this table freely for your records of the maintenance.

Model		Serial Number	
Items			
Engine	Open air cleaner evacuator valve to remove dust		
	Check fuel hoses and clamp bands		
	Clean fuel filter		
	Check water separator		
	Draining of water separator		
	Clean air cleaner element		
	Check of fan belt tightness		
	Check intake air line (air cleaner hose)		
	Check radiator hoses and clamp bands		
	Clean water separator		
	Clean fuel tank interior		
	Clean water jacket (radiator interior)		

Records

Records

Items											
Engine	Check valve clearance										
	Check of fuel injection nozzle injection pressure										
	Check of injection pump										
	Change engine oil										
	Replace engine oil filter cartridge										
	Replace fuel filter cartridge										
	Replace fan belt										
	Replace air cleaner element										
	Change radiator coolant (L.L.C.)										
	Replace radiator hoses and clamp bands										
	Replace fuel hoses and clamp bands										
	Replace intake air line (air cleaner hose) and clamp bands										
Main vehicle	Check hydraulic hose (Moving part)										
	Grease and lubricate										

Items											
Main vehicle	Check electrical wiring										
	Check wheel mounting bolts										
	Check hydraulic hose (Fixed part) condition										
	Grease hydraulic motor shaft of the mower unit										
	Adjust lift arm spring										
	Replace hydraulic oil										
	Replace hydraulic oil suction filter										
	Replace hydraulic oil line filter										
	Replace air breather element										
	Replace battery										
	Replace hydraulic hoses (Moving part)										
	Replace hydraulic hoses (Moving part) relating to steering										
	Replace hydraulic hoses (Fixed part)										
	Replace brake cables										

Records

Records

Items											
Main vehicle	Replace traveling cable										
	Replace throttle wire										
	Replace brake pads										

BARONESS[®]
Quality on Demand

 **KYOEISHA CO., LTD.**
Head Office 1-26, Miyuki-cho, Toyokawa-city, Tel :+81-533-84-1390
Aichi-pref, 442-8530 JAPAN Fax:+81-533-84-1220