

LM56GC · LM66GC ***LM66TC***

Walk Behind Greens Mower
Walk Behind Tee Mower

Owner's Operating Manual

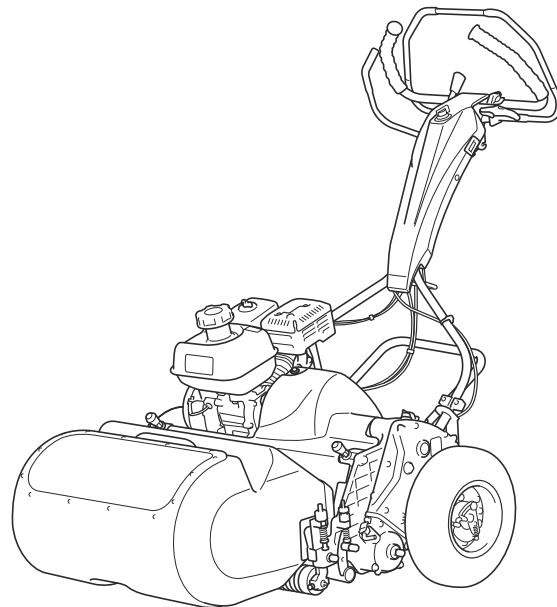

Serial No. LM56GC: 36481- · LM66GC: 36128-
LM66TC: 35329-

"Required reading"
Read this manual before using the machine.

BARONESS[®]
Quality on Demand

Original Instructions Ver.3.1

Regulations

EU Regulations

(For EU)

This product complies with all relevant EU Regulations.

For more information, please refer to the Declaration of Conformity attached.

Thank you for purchasing the Baroness product. This manual describes the proper handling, adjustment, and inspection of your product. We hope you will use the product safely, and take advantage of its best performance.

QR Code

(*QR Code is a registered trademark of DENSO WAVE INCORPORATED.)

A QR code label is affixed on the machine.

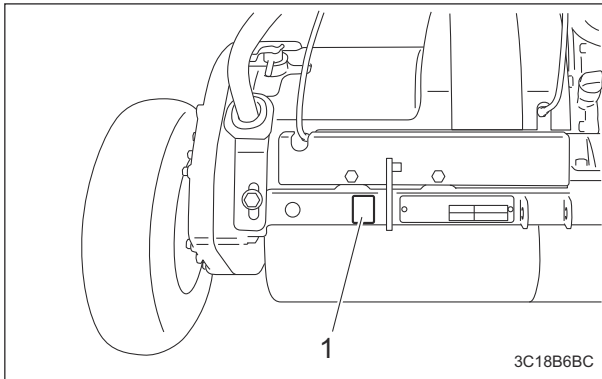

QR Code_001

1	QR code label
---	---------------

Scan the QR code with your smartphone for easy access to Baroness Manual Reference Service where you can browse Owner's Operating Manual and Parts Catalog.

LM56GC: <https://doc.baroness-international.com/manuals/LM56GC>

LM56GC-0901Z0

QR code LM56GC



QR Code_002

LM66GC: <https://doc.baroness-international.com/manuals/LM66GC>

LM66GC-0901Z0

QR code LM66GC



QR Code_003

LM66TC: <https://doc.baroness-international.com/manuals/LM66TC>

LM66TC-0901Z0

QR code LM66TC



QR Code_004

Introduction

Read this manual carefully to ensure that you thoroughly understand how to properly operate and maintain the product, and to avoid causing injury to yourself or others.

The operator is responsible for operating the product properly and safely.

Maintenance service for this machine should be performed by a mechanic with expertise.

If you have any questions concerning maintenance or genuine parts, please contact a Baroness dealer or Kyoisha.

When making inquiries about your product, please specify the model and serial number.

When loaning or transferring the product, please also provide this manual together with the product.

Kyoisha Co., Ltd.

Warning Symbols

This manual uses the following warning symbols for handling precautions that are important for your safety.



696cq5-001

Warning symbol

This symbol indicates the articles regarding “Danger,” “Warning,” or “Caution.”

Those articles describe important safety precautions and so read them carefully to understand completely before operating the machine.

Failure to adequately follow these safety precautions may cause an accident.

Danger

This symbol indicates that serious injury or death will occur if the warning is ignored.

Warning

This symbol indicates that serious injury or death may occur if the warning is ignored.

Caution

This symbol indicates that injury or damage to property may occur if the warning is ignored.

Important

This symbol indicates precautions on the mechanism of the machine.

Precautionary Statement

 Caution

The information described in this manual is subject to change for improvement without prior notice.

When replacing parts, be sure to use genuine Baroness parts or parts designated by Kyoisha.

Note that the Baroness product warranty may not apply to defects caused by the use of parts from other companies.

Prior to use, carefully read the following manuals to thoroughly understand the contents for safe and correct operation.

- Baroness Owner's Operating Manual
- The Engine's Owner's Manual

Purpose

This machine is intended for cutting turf grass at golf courses.

Do not use this machine in any way other than its intended purpose, and do not modify the machine.

Operating this machine for other purposes and modifying it may be very dangerous and may cause damage to the machine.

Introduction

Contents

Safety	Page 1-1	Supplying Fluids	Page 6-4
Safe Operating Practices	Page 1-2	Greasing	Page 6-4
Disposal	Page 2-1	Lubrication	Page 6-7
Recycle and Waste Disposal	Page 2-2	Adjustment	Page 6-8
Product Overview	Page 3-1	Replacement	Page 6-19
Specifications	Page 3-2	Storage	Page 6-29
Names of Each Section	Page 3-9	Repair	Page 7-1
Regulation Decals	Page 3-9	Precautions for Repair	Page 7-2
Safety Signs and Instruction Signs	Page 3-12	Adjustment	Page 7-2
Operation Decals	Page 3-14	Appended Table	Page 8-1
Description of Functions	Page 4-1	Tightening Torques	Page 8-2
Light Switch	Page 4-2	Daily Check List	Page 8-5
Engine Switch	Page 4-2	Maintenance Schedule	Page 8-6
Throttle Lever	Page 4-2	List of Adjusted Values	Page 8-8
Throttle Lever	Page 4-2	Troubleshooting Procedures of Aftercut Appearance	Page 8-9
Brake Lever	Page 4-3	Records	Page 9-1
Clutch Lock Lever	Page 4-3	Daily Check Records	Page 9-2
Main Clutch Lever	Page 4-3	Maintenance Records	Page 9-5
Traveling/Working Selector Lever	Page 4-4		
Air Adjusting Plate	Page 4-4		
Engine Clutch Cover	Page 4-4		
Groomer Clutch Lever	Page 4-5		
IGCA (Independent Grass Catcher Arm)	Page 4-5		
Instruments	Page 4-7		
Handling Instructions	Page 5-1		
Operations before Service	Page 5-2		
Preparation for Use	Page 5-2		
Inspection before Use	Page 5-3		
Adjustment before Work	Page 5-7		
Start/Stop of Engine	Page 5-8		
Parking and Stopping	Page 5-10		
Move	Page 5-11		
Cutting Work	Page 5-11		
Transporting	Page 5-13		
Cleaning after Use	Page 5-13		
Storage	Page 5-14		
Maintenance	Page 6-1		
Precautions for Maintenance	Page 6-2		
Position of Mower during Maintenance	Page 6-2		
Inspection and Cleaning	Page 6-2		

Contents

Safe Operating Practices Page 1-2

Training Page 1-2

Preparation Page 1-2

Operation Page 1-3

Maintenance Page 1-4

Storage Page 1-4

Safety

Safety

Failure to adequately follow these safety precautions may cause an accident resulting in injury or death.

Danger

This product is designed to ensure safe operation and has been tested and inspected thoroughly before shipment from the factory. The product is equipped with safety devices to prevent accidents.

However, whether the product demonstrates its original performance level depends on the manner in which it is operated and handled, as well as the manner in which it is managed on a daily basis.

Inappropriate use or management of the product may result in injury or death.

Observe the following safety instructions to ensure safe operation.

Safe Operating Practices

Training

1. Read this manual and other training material carefully.
Be familiar with the controls, safety signs, and the proper use of the equipment.
2. If the operator or mechanic can not read the language used in this manual, it is the owner's responsibility to explain this material to them.
3. All operators and mechanics should seek and obtain professional and practical instruction.
The owner is responsible for training the users.
4. Never allow people unfamiliar with these instructions to use or service the machine.
Local regulations may restrict the age of the operator.
5. The owner/user can prevent and is responsible for accidents or injuries occurring to themselves, other people, or property.
6. Keep in mind that the owner, operator, and mechanic are responsible for accidents or hazards occurring to other people or their property.
7. You can find additional safety information where needed throughout this manual.
8. Determine the left and right sides of the machine from the normal operating position.

Preparation

1. Evaluate the terrain to determine what accessories and attachments are needed to properly and safely perform the job.
Only use accessories and attachments approved by the manufacturer.
2. While operating, always wear substantial footwear, long trousers, hard hat, safety glasses, mask, and ear protection.
Long hair, loose clothing, or jewelry may get tangled in moving parts.
Do not operate the equipment when barefoot or wearing open sandals.
3. Inspect the area where the equipment is to be used and remove all objects such as rocks, toys and wire which can be thrown by the machine.
4. Keep children out of the operating area and under the watchful care of a responsible adult other than the operator.
5. Exercise care in the handling of fuel.

Warning

Fuel is highly flammable.
Take the following precautions:

- [1] Store fuel in containers specifically designed for this purpose.
- [2] Add fuel before starting the engine.
Never remove the cap of the fuel tank or add fuel while the engine is running or when the engine is hot.
- [3] Refuel outdoors only and do not smoke while refueling.
- [4] If fuel is spilled, do not attempt to start the engine but move the machine away from the area of spillage and avoid creating any source of ignition until petrol vapours have dissipated;
- [5] Replace all fuel tanks and container caps securely.
6. Check that operator's presence controls, safety switches and shields are attached and functioning properly.
Do not operate unless they are functioning properly.
7. If the brake operation is faulty, be sure to adjust or repair them before operating the machine.

8. If the handlebar has noticeable play, be sure to adjust or repair them before operating the machine.
9. Replace faulty mufflers.

Operation

1. Do not operate the machine under the influence of alcohol or drugs.
2. Do not operate the engine in a confined space where dangerous carbon monoxide fumes can collect.
3. Be sure all drives are in neutral and parking brake is engaged before starting engine.
4. Start the engine or switch on the motor carefully according to this manual and with feet well away from the cutting section.
5. Do not change the engine governor settings or overspeed the engine.
Operating the engine at excessive speed may increase the hazard of personal injury.
6. Pay attention not to touch hot parts.
7. Never operate the machine with damaged guards, shields, or without safety protective devices in place.
Be sure all interlocks are attached, adjusted properly, and functioning properly.
8. Keep hands and feet away from the rotating parts.
9. Never pick up or carry the machine in operation.
10. Never operate while people, especially children, or pets are nearby.
11. Only operate in good light, keeping away from holes and hidden hazards.
12. Do not operate the machine when there is the risk of lightning.
13. Walk, never run.
14. Do not stop or start suddenly.
15. Avoid operating the equipment in wet grass, where feasible.
16. Look behind and down before backing up to be sure of a clear path.
17. Slow down and use caution when making turns and crossing roads and sidewalks.
18. Use care when approaching blind corners, shrubs, trees, or other objects that may obscure vision.
19. Do not take your eyes off the road ahead.
Do not operate the machine with no hands.
20. Always be sure of your footing on slopes.
21. Remember there is no such thing as a safe slope.
Travel on grass slopes requires particular care.
To guard against overturning, follow these instructions.
 - [1] Do not operate the machine on excessively steep slopes.
 - [2] Do not stop or start suddenly when going up or downhill.
 - [3] Engage clutch slowly, always keep machine in gear, especially when traveling downhill.
 - [4] Machine speeds should be kept low on slopes and during turns.
22. Use extra care while operating machine with a grass catcher or other attachments.
They can affect the stability of the machine.
23. Disengage drive to the cutting section, when other than operating.
24. Do the following before leaving the operator's position.
 - [1] Stop on level ground.
 - [2] Disengage the all drives.
 - [3] Set the parking brake.
 - [4] Stop the engine.
25. Stop the engine in the following conditions.
 - [1] Before refuelling.
 - [2] Before removing the grass catcher.
 - [3] Before making height or depth adjustment unless adjustment can be made from the operator's position.
 - [4] Before clearing blockages.
 - [5] Before checking, cleaning or working on the machine.
 - [6] After striking a foreign object or if an abnormal vibration occurs.
Inspect the machine for damage and make repairs before restarting and operating the equipment.
26. Reduce the throttle setting during engine run-out.
27. Do not direct discharge material toward anyone.
Avoid discharging material against a wall or obstruction.
Material may ricochet back toward the operator.

Safety

28. Take care when loading or unloading the machine into a trailer or a truck.
Load or unload the machine in a flat and safe place.
Before loading or unloading, set the parking brake on the truck or trailer, stop the engine, and chock the wheels.
When transporting the machine on a truck or a trailer, set the parking brake, stop the engine, and fasten the machine to the truck with a rope or other suitable restraining device that has sufficient strength.
When using a running board, select one with sufficient strength, length, and width and that will not cause the machine to slip.
29. Close the fuel valve before transporting the machine.

Maintenance

1. Never allow untrained personnel to service machine.
2. Implement the following work before adjusting, cleaning or repairing.
 - [1] Stop the machine on level ground.
 - [2] Disengage drive to the cutting section.
 - [3] Set the parking brake.
 - [4] Stop the engine.
 - [5] Disconnect spark plug wire.
 - [6] Wait for all movement to stop.
3. Allow the engine/muffler to cool before checking/maintenance.
4. To reduce the fire hazard, keep hot parts such as the engine and silencer/muffler, and fuel storage area free of grass, leaves, or excessive grease.
Clean up oil or fuel spillage.
5. Appropriately manage and correctly use the tools necessary for servicing or adjusting the machine.
6. Use jack stands to support components when required.
7. Keep hands and feet away from moving parts.
If possible, do not make adjustments with the engine running.
8. Make sure that parts such as wires are not touching each other and that their covers have not come off.
9. Keep all parts in good working condition and all hardware tightened.
Replace all worn or damaged decals.

10. Keep all nuts, bolts and screws tight to be sure the equipment is in safe working condition.
11. Carefully release pressure from components with stored energy.
12. Use care when checking the cylinders/reels and bed knives.
Wear gloves and use caution when servicing them.
13. Be careful during adjustment of the machine to prevent entrapment of the fingers between moving blades and fixed parts of the machine.
14. Check the grass catcher frequently for wear or deterioration.
15. If the fuel tank has to be drained, do this outdoors.

Storage

1. Allow the engine to cool before storing in any enclosure.
2. Only cover the machine with a sheet after hot parts have sufficiently cooled down.
3. Never store the equipment with fuel in the tank inside a building where fumes may reach an open flame or spark.
4. If the engine is provided with a shut-off valve, shut off valve while storing or transporting.
5. Do not store fuel near flames.

Recycle and Waste Disposal Page 2-2

About RecyclePage 2-2

About Waste Disposal Page 2-2

Disposal

Recycle and Waste Disposal

About Recycle

Recycling battery etc. is recommended for environmental conservation and economical use of resources.

It may be required by local laws.

About Waste Disposal

Make sure that waste generated when servicing or repairing the machine is disposed of in accordance with local regulations. (e.g. waste oil, antifreeze, rubber products, and wires etc.)

Specifications Page 3-2

- Specifications List Page 3-2
- Sound Pressure Level Page 3-8
- Sound Power Level Page 3-8
- Vibration Level Page 3-8
- Carbon Dioxide (CO₂) Emissions Page 3-8

Names of Each Section Page 3-9

Regulation Decals Page 3-9

- Positions of Regulation Decals Page 3-9
- Description of Regulation Decals Page 3-10

Safety Signs and Instruction Signs ... Page 3-12

- About Safety Signs and Instruction
Signs Page 3-12
- Positions of Safety Decals and
Instruction Decals Page 3-12
- Description of Safety Decals and
Instruction Decals Page 3-12

Operation Decals Page 3-14

- Positions of Operation Decals Page 3-14
- Description of Operation Decals Page 3-14

Product Overview

Specifications

Specifications List

LM56GC

Model		LM56GC	
Name		Walk Behind Greens Mower	
Dimensions	Total length	with grass catcher	141 cm 55.51 in
	Total width	without travelling wheel	94 cm 37.01 in
	Total height	Handle	116 cm 45.67 in
Weight	Machine (empty fuel tank)		102 kg 224.87 lb
	Grass catcher *1		3.3 kg 7.28 lb
	Groomer *1		3.6 kg 7.94 lb
	Travelling wheel (for one machine) *1		6.9 kg 15.21 lb
Minimum turning radius		-	
Engine	Model		HONDA GX120
	Type		Gasoline air-cooled engine (OHV) four-stroke single-cylinder
	Total displacement		122 cm ³ (0.122 L) 7.44 cu.in.
	Maximum output		2.4 kW (3.3 PS)/3,600 rpm
	Rated output		2.1 kW (2.9 PS)/3,600 rpm
Fuel tank capacity		Gasoline 2.0 dm ³ (2.0 L)	Gasoline 0.53 U.S.gals
Fuel consumption		338 g/kW · h (rated output)	248.60 g/PS · h (rated output)
Engine oil capacity		0.56 dm ³ (0.56 L)	0.15 U.S.gals
Coolant volume		-	
Hydraulic tank capacity		-	
Transmission oil capacity		-	
Operating width (Mowing width)		55.7 cm	22 in
Operating height (Mowing height)		3.0 (4.5) - 29.0 mm [3.0 (4.5) - 27.0 mm] *2	0.118 (0.177) - 1.142 in [0.118 (0.177) - 1.063 in] *2
Number of Blades		11	
Drive	Traveling	Mechanical	
	Mowing	Mechanical	
Speed (HST)		-	
Speed (Mechanical)		4.7 km/h (@3,000 rpm)	2.92 mph (@3,000 rpm)
Efficiency		2,094 m ² /h (4.7 km/h x mowing width x 0.8)	0.51 acres/hour (2.92 mph x mowing width x 0.8)
Maximum inclination for operation		-	
Tire size		4.10/3.50-6	
Tire pneumatic pressure		120 kPa (1.2 kgf/cm ²)	17 psi
Battery		-	
Engine plug		NGK BPR4ES	

The factory default maximum engine rpm is 3,300 rpm.

*1: Weight (Machine) includes *1 parts.

*2: The indicated lowest mowing height is for general application. It may be adjusted according to the state of green and the bed knife to be installed.

The value in the brackets [] is the mowing height of the machine equipped with a groomer.

The value in the brackets () is the mowing height of the machine equipped with a standard bed knife.

Product Overview

LM66GC

Model		LM66GC	
Name		Walk Behind Greens Mower	
Dimensions	Total length	with grass catcher	141 cm 55.51 in
	Total width	without travelling wheel	103 cm 40.55 in
	Total height	Handle	116 cm 45.67 in
Weight	Machine (empty fuel tank)		109 kg 240.30 lb
	Grass catcher *1		3.6 kg 7.94 lb
	Groomer *1		4.0 kg 8.82 lb
	Travelling wheel (for one machine) *1		6.9 kg 15.21 lb
Minimum turning radius		-	
Engine	Model		HONDA GX120
	Type		Gasoline air-cooled engine (OHV) four-stroke single-cylinder
	Total displacement		122 cm ³ (0.122 L) 7.44 cu.in.
	Maximum output		2.4 kW (3.3 PS)/3,600 rpm
	Rated output		2.1 kW (2.9 PS)/3,600 rpm
Fuel tank capacity		Gasoline 2.0 dm ³ (2.0 L)	Gasoline 0.53 U.S.gals
Fuel consumption		338 g/kW · h (rated output)	248.60 g/PS · h (rated output)
Engine oil capacity		0.56 dm ³ (0.56 L)	0.15 U.S.gals
Coolant volume		-	
Hydraulic tank capacity		-	
Transmission oil capacity		-	
Operating width (Mowing width)		64.6 cm	26 in
Operating height (Mowing height)		3.0 (4.5) - 29.0 mm [3.0 (4.5) - 27.0 mm] *2	0.118 (0.177) - 1.142 in [0.118 (0.177) - 1.063 in] *2
Number of Blades		11	
Drive	Traveling		Mechanical
	Mowing		Mechanical
Speed (HST)		-	
Speed (Mechanical)		4.7 km/h (3,000 rpm)	2.92 mph (3,000 rpm)
Efficiency		2,429 m ² /h (4.7 km/h x mowing width x 0.8)	0.60 acres/hour (2.92 mph x mowing width x 0.8)
Maximum inclination for operation		-	
Tire size		4.10/3.50-6	
Tire pneumatic pressure		120 kPa (1.2 kgf/cm ²)	17 psi
Battery		-	
Engine plug		NGK BPR4ES	

The factory default maximum engine rpm is 3,300 rpm.

*1: Weight (Machine) includes *1 parts.

*2: The indicated lowest mowing height is for general application. It may be adjusted according to the state of green and the bed knife to be installed.

The value in the brackets [] is the mowing height of the machine equipped with a groomer.

The value in the brackets () is the mowing height of the machine equipped with a standard bed knife.

Product Overview

LM66TC

Model		LM66TC	
Name		Walk Behind Tee Mower	
Dimensions	Total length	with grass catcher	141 cm 55.51 in
	Total width	without travelling wheel	103 cm 40.55 in
	Total height	Handle	116 cm 45.67 in
Weight	Machine (empty fuel tank)		107 kg 235.89 lb
	Grass catcher *1		3.6 kg 7.94 lb
	Groomer *1		4.0 kg 8.82 lb
	Travelling wheel (for one machine) *1		6.9 kg 15.21 lb
Minimum turning radius		-	
Engine	Model		HONDA GX120
	Type		Gasoline air-cooled engine (OHV) four-stroke single-cylinder
	Total displacement		122 cm ³ (0.122 L) 7.44 cu.in.
	Maximum output		2.4 kW (3.3 PS)/3,600 rpm
	Rated output		2.1 kW (2.9 PS)/3,600 rpm
Fuel tank capacity		Gasoline 2.0 dm ³ (2.0 L)	Gasoline 0.53 U.S.gals
Fuel consumption		338 g/kW · h (rated output)	248.60 g/PS · h (rated output)
Engine oil capacity		0.56 dm ³ (0.56 L)	0.15 U.S.gals
Coolant volume		-	
Hydraulic tank capacity		-	
Transmission oil capacity		-	
Operating width (Mowing width)		64.6 cm	26 in
Operating height (Mowing height)		4.5 (7.0) - 29.0 mm [4.5 (7.0) - 27.0 mm] *2	0.177 (0.276) - 1.142 in [0.177 (0.276) - 1.063 in] *2
Number of Blades		7	
Drive	Traveling		Mechanical
	Mowing		Mechanical
Speed (HST)		-	
Speed (Mechanical)		4.3 km/h (@3,000 rpm)	2.67 mph (@3,000 rpm)
Efficiency		2,222 m ² /h (4.3 km/h x mowing width x 0.8)	0.55 acres/hour (2.67 mph x mowing width x 0.8)
Maximum inclination for operation		-	
Tire size		4.10/3.50-6	
Tire pneumatic pressure		120 kPa (1.2 kgf/cm ²)	17 psi
Battery		-	
Engine plug		NGK BPR4ES	

The factory default maximum engine rpm is 3,300 rpm.

*1: Weight (Machine) includes *1 parts.

*2: The indicated lowest mowing height is for general application. It may be adjusted according to the state of green and the bed knife to be installed.

The value in the brackets [] is the mowing height of the machine equipped with a groomer.

The value in the brackets () is the mowing height of the machine equipped with a standard bed knife.

Product Overview

Sound Pressure Level

LM56

■ Sound Pressure Level

This machine was confirmed to have a continuous A-weighted sound pressure level of 87 dB by measuring identical machines in accordance with the procedure specified in ISO 5395-1:2013.

LM66

■ Sound Pressure Level

This machine was confirmed to have a continuous A-weighted sound pressure level of 87 dB by measuring identical machines in accordance with the procedure specified in ISO 5395-1:2013.

Sound Power Level

LM56

■ Sound Power Level

This machine was confirmed to have a sound power level of 98 dB by measuring identical machines in accordance with the procedure specified in ISO5395-1:2013.

LM66

■ Sound Power Level

This machine was confirmed to have a sound power level of 98 dB by measuring identical machines in accordance with the procedure specified in ISO5395-1:2013.

Vibration Level

LM56

■ Hand-Arm Vibration

This machine was confirmed not to exceed a vibration level of 2.5 m/s² to hands and arms by measuring identical machines in accordance with the procedure specified in ISO 5395-1:2013.

LM66

■ Hand-Arm Vibration

This machine was confirmed not to exceed a vibration level of 2.5 m/s² to hands and arms by measuring identical machines in accordance with the procedure specified in ISO 5395-1:2013.

Carbon Dioxide (CO₂) Emissions

For the CO₂ values on Honda engine, refer to the following website.
<http://www.honda-engines-eu.com/co2-engines>
This CO₂ measurement results from testing over a fixed test cycle under laboratory conditions of a(an) (parent) engine representative of the engine type (engine family) and shall not imply or express any guarantee of the performance of a particular engine.

Names of Each Section

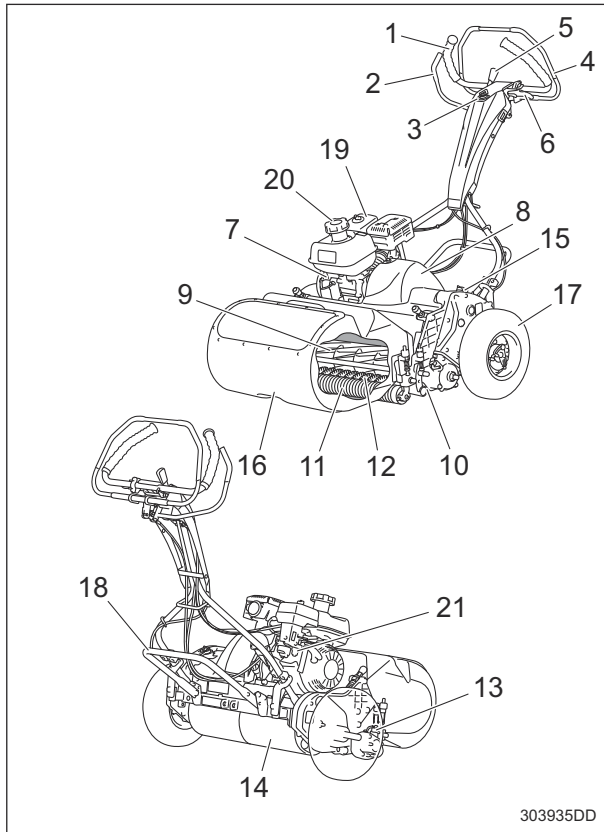

Names of Each Section_001

1	Handle
2	Throttle lever
3	Engine switch
4	Main clutch lever
5	Clutch lock lever
6	Brake lever
7	Engine
8	Engine clutch cover
9	Reel cutter
10	Bed knife
11	Front roller
12	Groomer
13	Groomer clutch lever
14	Drum
15	Traveling/ Working selector lever
16	Grass catcher
17	Traveling tire
18	Stand
19	Air cleaner
20	Fuel tank
21	Fuel strainer

Regulation Decals

Positions of Regulation Decals

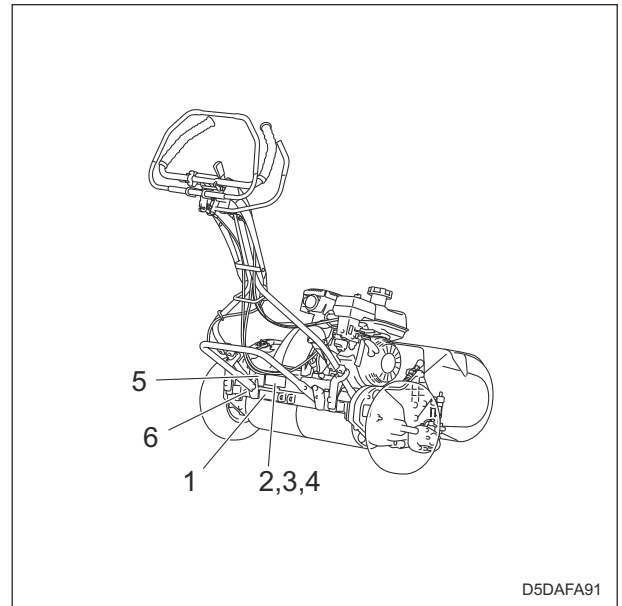

Positions of Regulation Decals_001

1	Serial number plate
2	Specification decal
3	CE mark
4	UKCA mark (LM56GC: #36001-36361, LM66GC: #35836-36098, LM66TC: #35212-35329)
5	Noise emission decal
6	Year of manufacture decal

Product Overview

Description of Regulation Decals

Serial Number Plate

The following information is written on the serial number plate.

1. Model
2. Serial number
3. Registered trademark
4. Manufacturer
 - Company name
 - Postal address/Address
 - Website

Contact the manufacturer via the contact form on the website.



Serial Number Plate_001

Specification Decal

(For EU)
The Specification decal indicates the model and weight, etc.

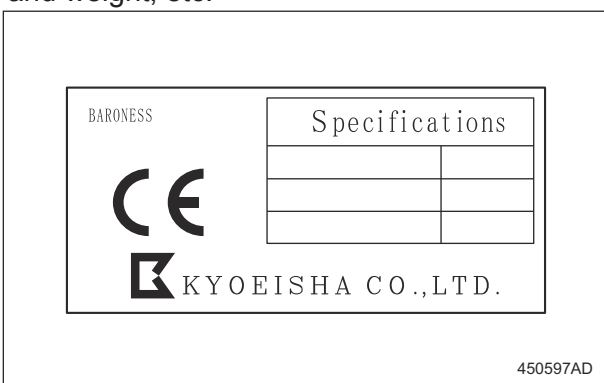

Specification Decal_001

CE Mark

(For EU)
CE mark indicates that the machine sold in the EU nations complies with the EU requirements.

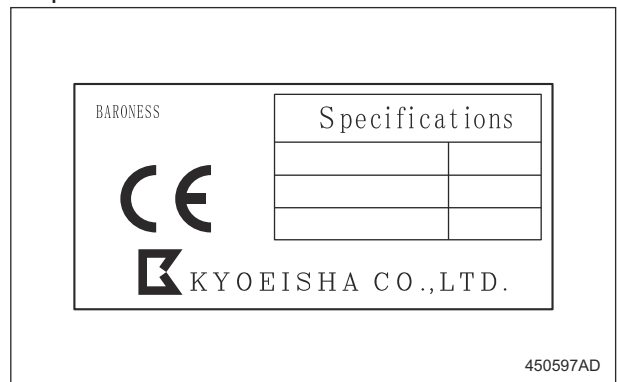

CE Mark_001

UKCA Mark

(For UK)
UKCA mark indicates that the machine sold in the UK complies with the UK requirements.



UKCA Mark_001

Noise Emission Decal

(For EU)

The noise emission decal indicates the sound power level determined by measuring identical machines in accordance with the procedure specified in the regulations of EU.

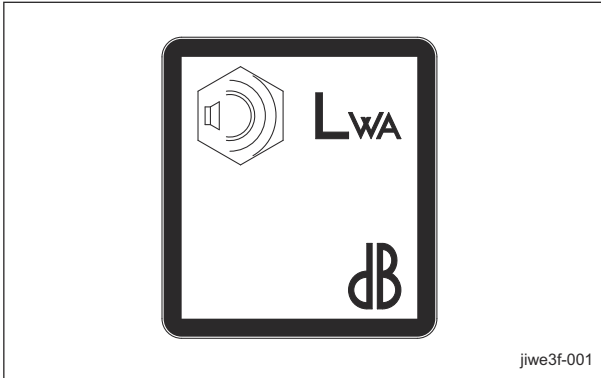

Noise Emission Decal_001

Year of Manufacture Decal

(For EU)

The year of manufacture decal indicates the year when this machine was manufactured.

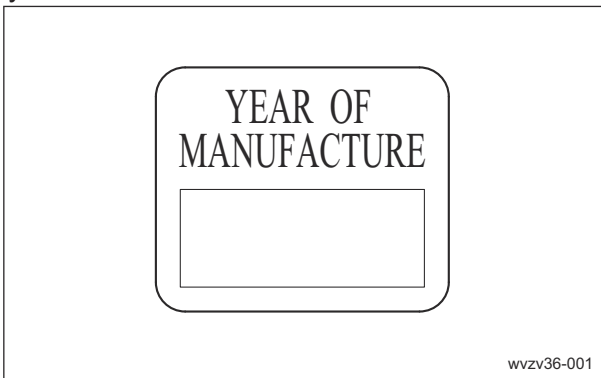

Year of Manufacture Decal_001

Product Overview

Safety Signs and Instruction Signs

About Safety Signs and Instruction Signs

Important

Safety decals and instruction decals are attached to this product. Make sure that they are preserved in their entirety. If they are damaged, become dirty, or peel off, replace them with new ones.

Part numbers for decals that need to be replaced are listed in the parts catalog. Order them from a Baroness dealer or Kyoeshia.

Positions of Safety Decals and Instruction Decals

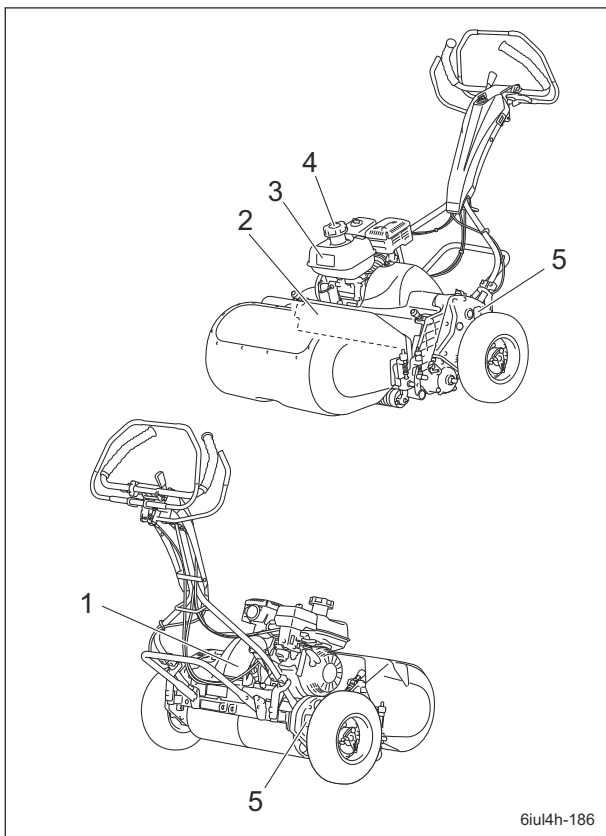

Positions of Safety Decals and Instruction Decals_001

1	Caution safety instruction decal
2	Caution to mutilation decal
3	Caution to noise decal
4	Warning engine oil decal
5	Greasing 10HR decal

Description of Safety Decals and Instruction Decals

Caution Safety Instruction Decal

K4205001590

DECAL, CAUTION SAFETY INSTRUCTION

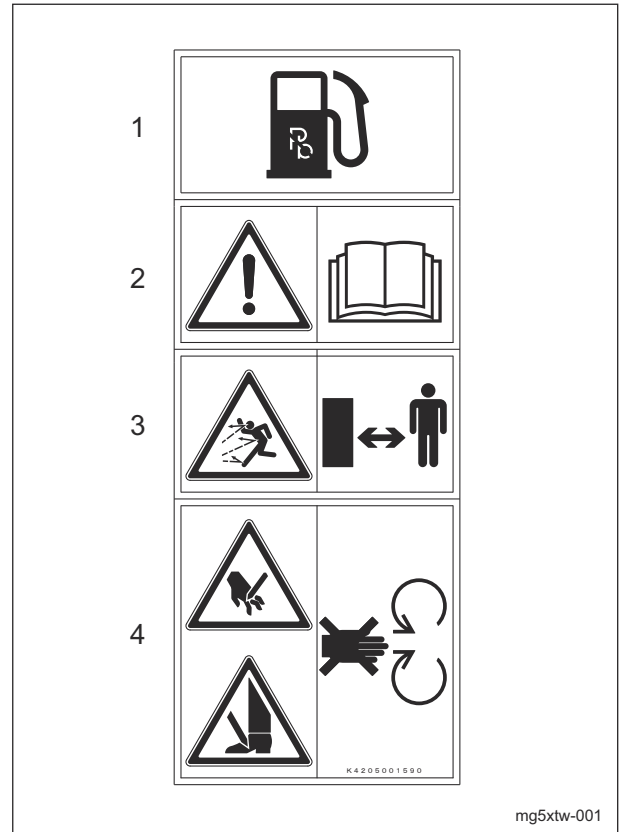

Caution Safety Instruction Decal_001

1. Use lead-free gasoline.
- 2.

Warning

Read the Owner's Operating Manual.

- 3.

Caution

Thrown objects - Be sure that people around the machine keep a safe distance away.

- 4.

Warning

May cut your hand or leg - When the blades are rotating, keep hands and feet away from moving parts.

Caution to Mutilation Decal

K4205001600
DECAL, CAUTION TO MUTILATION

 Warning

May cut your hand or leg - Stop the cutter rotation and engine. Otherwise you may get injured.

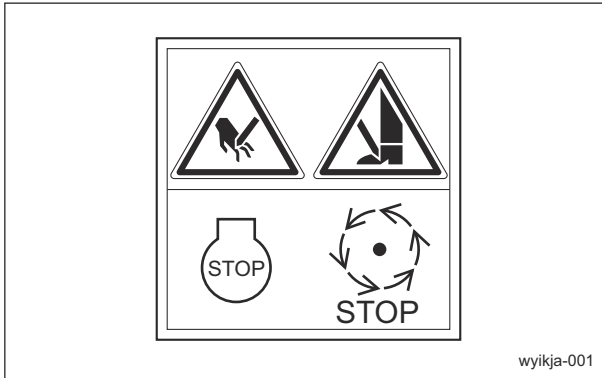

Caution to Mutilation Decal_001

Engine Oil Warning Decal

K4205001300
DECAL, WARNING ENGINE OIL

Important

Check engine oil and gearbox levels before starting.



Engine Oil Warning Decal_001

Caution to Noise Decal

K4205001330
DECAL, CAUTION TO NOISE

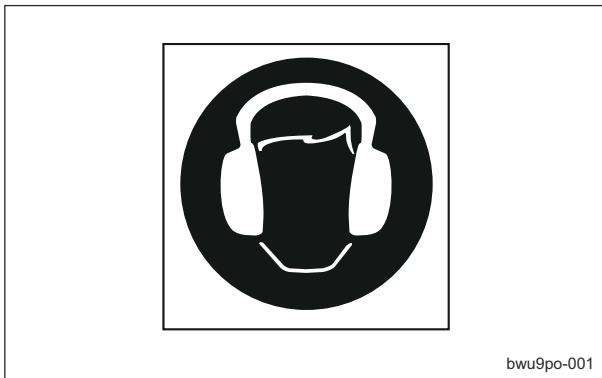

Caution to Noise Decal_001

Greasing Each 10-Hours Decal

K4209000370
DECAL, GREASING EACH 10-HOURS
Add grease every 10 hours.

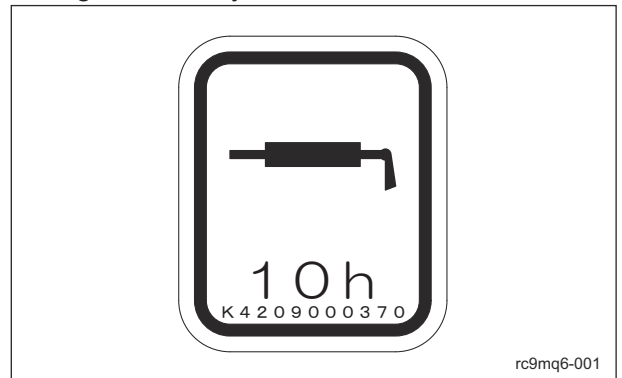

Greasing Each 10-Hours Decal_001

Product Overview

Operation Decals

Positions of Operation Decals

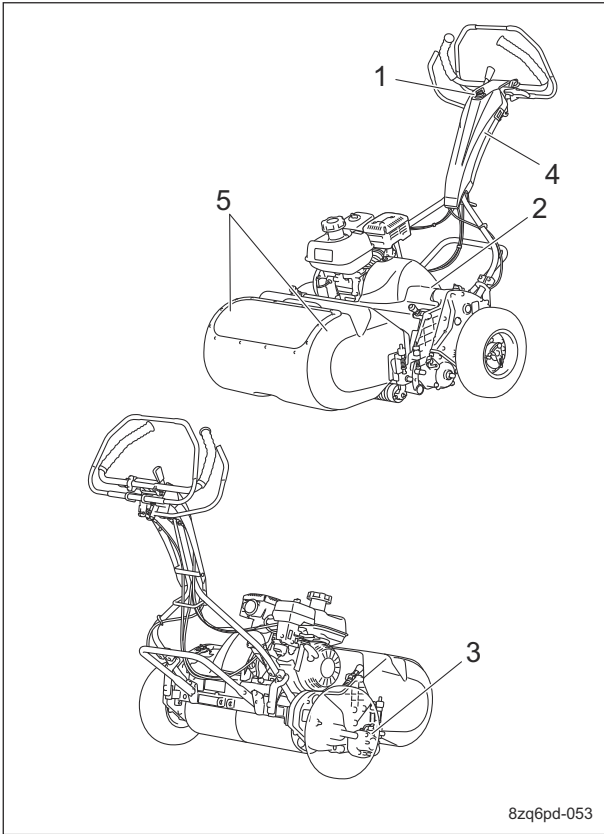

Positions of Operation Decals_001

1	Decal, engine switch
2	Decal, clutch
3	Decal, groomer indication
4	Decal, light switch
5	Sticker, alignment 10300

Description of Operation Decals

Engine Switch Mark

ENGINE SWITCH MARK

It illustrates the positions of the engine switch.

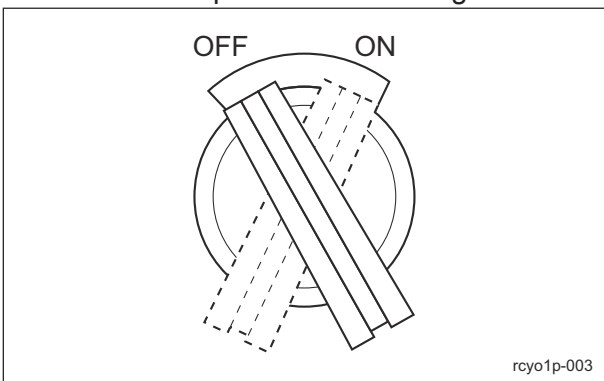

Engine Switch Mark_001

Clutch Decal

K4203001110
STICKER, CLUTCH

This indicates operating positions (traveling/working) for the reel cutter (cutting cylinder) and drum.

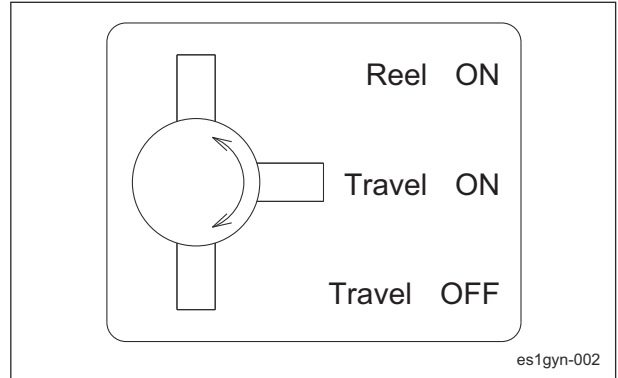

Clutch Decal_001

Groomer Indication Mark

Note:

Depending on the specifications, this function may not be available.

K4203001120
DECAL, GROOMER INDICATION

It illustrates the changeover of rotational direction of the groomer.

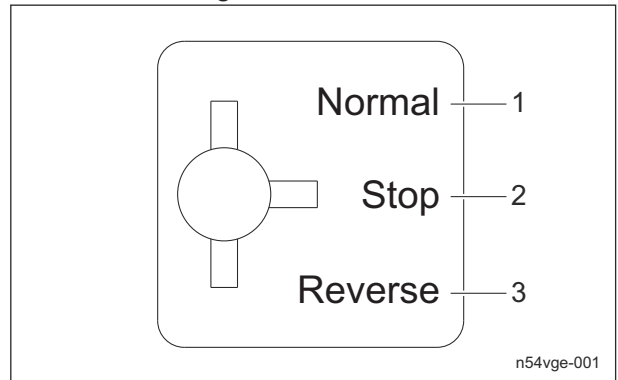

Groomer Indication Mark_001

1	Normal rotation
2	Stop
3	Reverse rotation

Light Switch Mark

Note:
 Depending on the specifications, this function may not be available.
 K4203001610
 DECAL, LIGHT SWITCH
 It illustrates ON/OFF of the light.

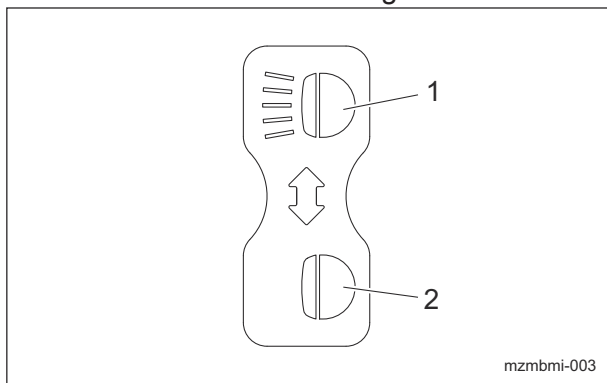

Light Switch Mark_001

1	ON
2	OFF

Red Alignment Mark 10300

Note:
 Depending on the specifications, this function may not be available.
 K4209001230
 DECAL, ALIGNMENT 10300 (SET OF 2PCS)
 Affix the decals in indicative positions on the grass catcher for operational support.

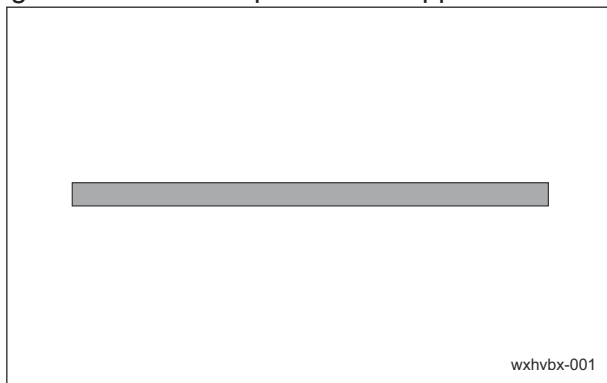

Red Alignment Mark 10300_001

Product Overview

Description of Functions

Light Switch	Page 4-2
Engine Switch	Page 4-2
Throttle Lever	Page 4-2
Throttle Lever	Page 4-2
Brake Lever	Page 4-3
Clutch Lock Lever	Page 4-3
Main Clutch Lever	Page 4-3
Traveling/Working Selector Lever	Page 4-4
Air Adjusting Plate	Page 4-4
Engine Clutch Cover	Page 4-4
Groomer Clutch Lever	Page 4-5
IGCA (Independent Grass Catcher Arm)	Page 4-5
Instruments	Page 4-7
Hour Meter	Page 4-7

Description of Functions

Light Switch

Note:
Depending on the specifications, this function may not be available.
The light switch is located in the handle panel. Flip up the switch to turn on the light, and down to turn off.

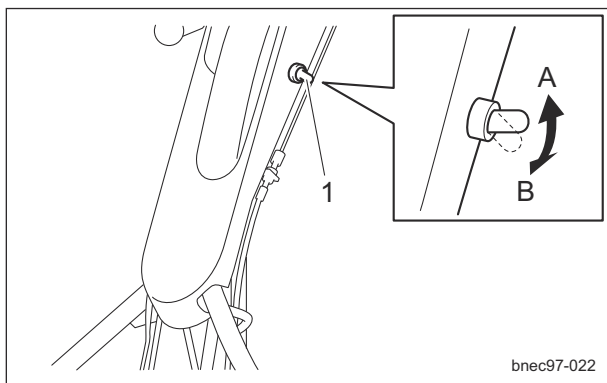

Light Switch_001

1	Light switch
A	ON
B	OFF

Engine Switch

The engine switch is located in the handle. To start the engine, set the engine switch to the "ON" position, and to stop it, set to the "OFF" position.

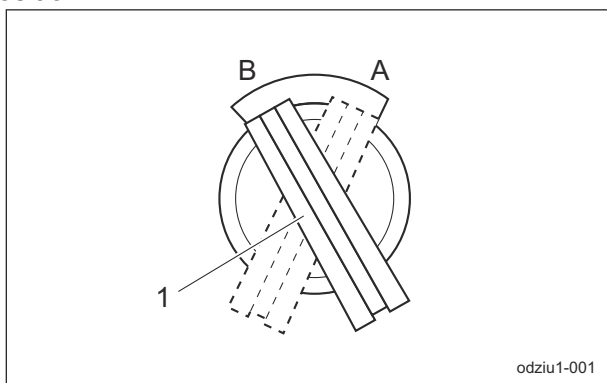

Engine Switch_001

1	Engine switch
A	ON
B	OFF

Throttle Lever

Note:
Depending on the specifications, this function may not be available.
The throttle lever is located in the handle and enables you to adjust the engine rpm. Grip the throttle lever tightly to move it toward "High speed" position for increasing the engine rpm, and loosen grip to move it toward "Low speed" position for decreasing the rpm.

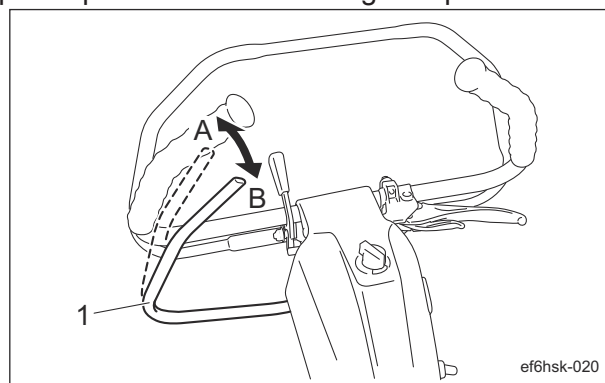

Throttle Lever_001

1	Throttle lever
A	High speed
B	Low speed

Throttle Lever

Note:
Depending on the specifications, this function may not be available.
The throttle lever is located in the handle and enables you to adjust the engine rpm. Move the throttle knob toward the "High speed" position to increase the engine rpm, and toward the "Low speed" position to reduce the rpm.

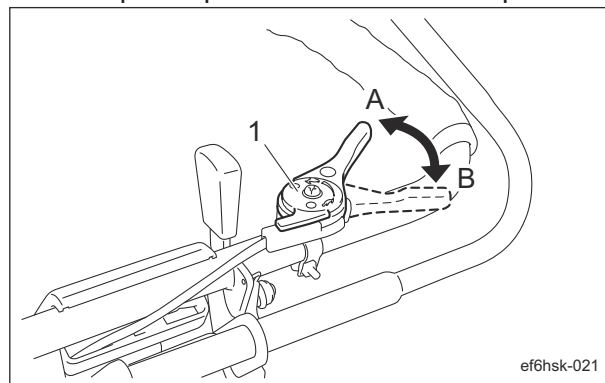

Throttle Lever_001

1	Throttle lever
A	High speed
B	Low speed

Description of Functions

Brake Lever

Caution

Avoid quick operation.
Carefully and slowly operate the machine.

The brake lever is located in the handle.
Grip the brake lever to activate braking and the travel of the machine is stopped.
Grip the lock lever while gripping the brake lever to lock the brake lever with braking applied.
Grip the locked brake lever to release locking.
Note:
Lock the brake lever to apply Parking Brake.

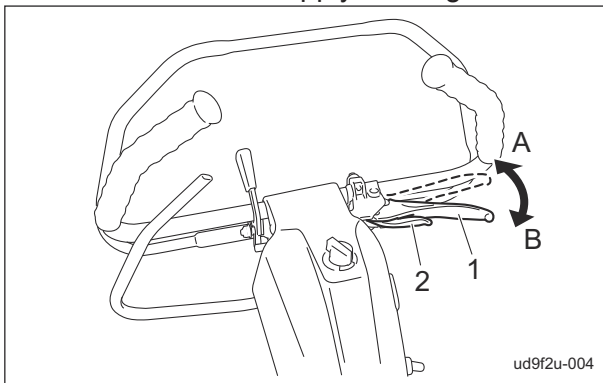

Brake Lever_001

1	Brake lever
2	Lock lever
A	Lock
B	Unlock

Clutch Lock Lever

The clutch lock lever is located in the handle.

Important

While the main clutch is in the "OFF" position, the safety lock is activated.

Grip the main clutch lever while tilting the clutch lock lever to "Unlock" side to unlock the safety lock.

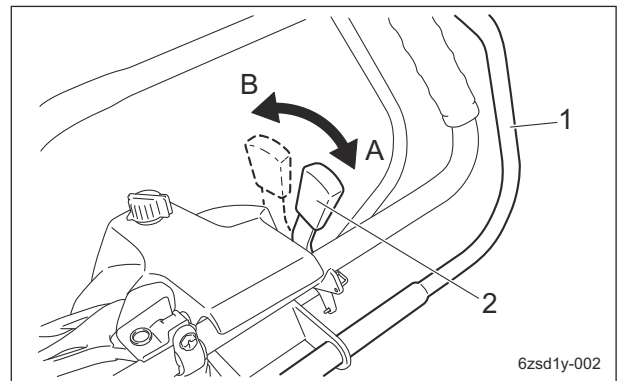

Clutch Lock Lever_001

1	Main clutch lever
2	Clutch lock lever
A	Lock
B	Unlock

Main Clutch Lever

Caution

Avoid quick operation.
Carefully and slowly operate the machine.

Important

The main clutch is not activated unless the safety lock released.

The main clutch lever is located in the handle.
Unlock the safety lock and then grip the main clutch lever to traveling forward with rotating the reel cutter.
Release the main clutch lever from the hands to stop the machine traveling and the reel cutter rotating.

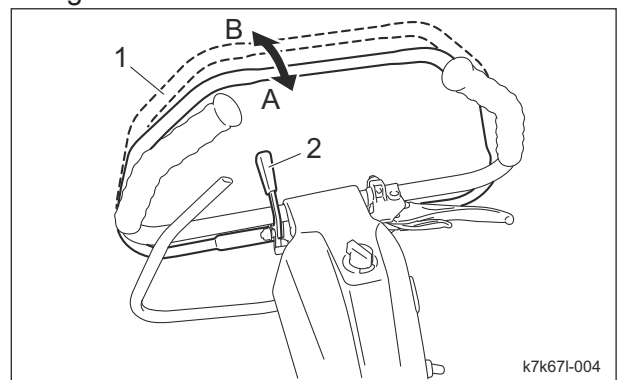

Main Clutch Lever_001

1	Main clutch lever
2	Clutch lock lever
A	ON
B	OFF

Description of Functions

Traveling/Working Selector Lever

Caution

This lever should be operated while the main clutch lever is set to the disengaged position, and adjusted to the position suitable for your work.

The traveling/working selector lever is located on top of the left frame and has three positions. When the lever is set to the "Reel ON" position, the drum and reel cutter (cutting cylinder) operate and cutting is performed.

When the lever is set to the "Travel ON" position, only the drum operates and the machine travels.

When the lever is set to the "Travel OFF" position, both the drum and reel cutter (cutting cylinder) are not driven.

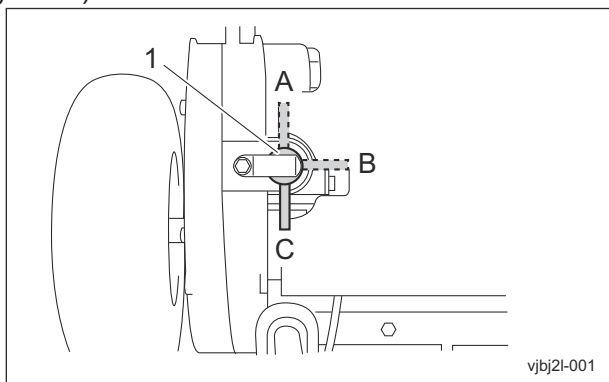

Traveling/Working Selector Lever_001

1	Traveling/Working selector lever
A	Reel ON
B	Travel ON
C	Travel OFF

Air Adjusting Plate

The air adjusting plate is attached on the reel cover of the mower unit and it adjusts the dispersing angle of clippings.

1. Move the air adjusting plate closer to the reel cutter when the lawn condition is dry.

2. Move the air adjusting plate away from the reel cutter when the lawn condition is wet.

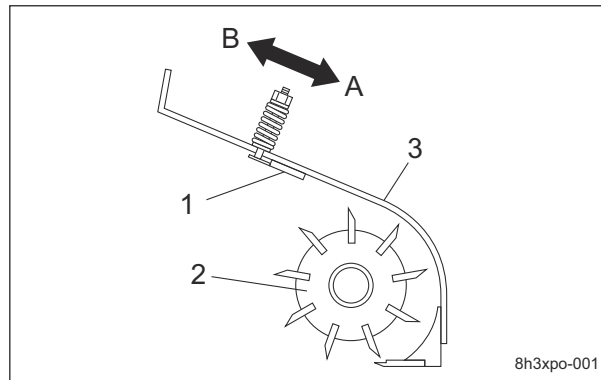

Air Adjusting Plate_001

1	Air adjusting plate
2	Reel cutter
3	Reel cover
A	Close
B	Away

Engine Clutch Cover

The engine clutch cover is located on the left side of the engine and covers the engine clutch. Open or close the engine clutch cover by removing or installing the lock bolt.

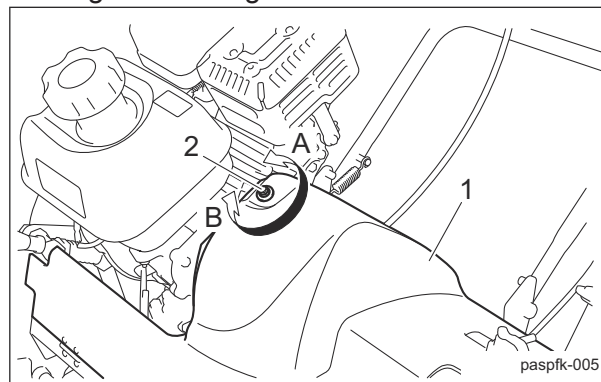

Engine Clutch Cover_001

1	Engine clutch cover
2	Lock bolt
A	Loosen
B	Tighten

Description of Functions

Groomer Clutch Lever

Note:
Depending on the specifications, this function may not be available.

⚠ Caution

This lever should be operated while the main clutch lever is set to the disengaged position, and adjusted to the position suitable for your work.

The groomer clutch lever is located on the upper side of the right frame and has three positions. When the lever is set to the "Normal" position, the groomer rotates in the same direction as the reel cutter (cutting cylinder). When the lever is set to the "Reverse" position, the groomer rotates in the opposite direction as the reel cutter (cutting cylinder). When the lever is set to the "Stop" position, the groomer will not rotate.

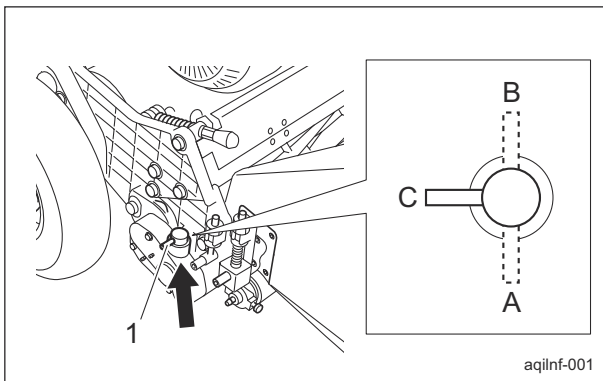

Groomer Clutch Lever_001

1	Groomer clutch lever
A	Normal
B	Reverse
C	Stop

IGCA (Independent Grass Catcher Arm)

Note:
Depending on the specifications, this function may not be available. (IGCA can be installed onto the LM18GC/ LM56GC.)
IGCA is located above the cutting section. The IGCA is a mechanism that prevents the mowing attitude of the cutting section from changing, even when there is an increase in the volume of clippings entering the grass catcher.

It eliminates as much as possible the transfer of rough handle movements causing changes in the cutting section attitude. Since the cutting section is stabilized while the lawn is mowed, even if the handle is treated roughly, the cutting height does not change from the start of mowing the green to the end. Stable lawn mowing work can be performed regardless of the operator's skill level and machine proficiency level, enabling all greens to be mowed at a uniform cutting height.

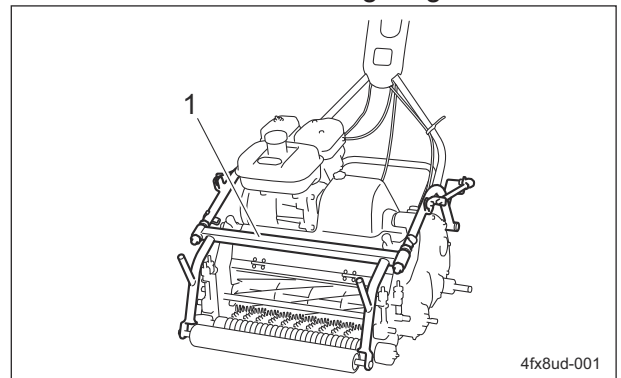

IGCA (Independent Grass Catcher Arm)_001

1	IGCA
---	------

Issue 1:
The cutting height fluctuates due to the up-and-down movements of the cutting section caused by the weight of the grass catcher.

Solution:

The cutting section and grass catcher operate independently. Therefore, the mowing attitude of the cutting section is not affected, even when the grass catcher becomes heavier from the added weight of grass, thatch, sand, etc. The operator can mow at a uniform cutting height from the start of mowing the green to the end.

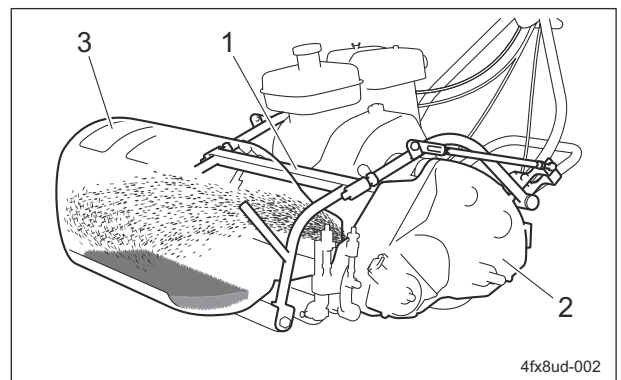

IGCA (Independent Grass Catcher Arm)_002

Description of Functions

1	IGCA
2	Cutting section
3	Grass catcher

Issue 2:

The cutting height is uneven due to the up-and-down movements of the cutting section caused by the operator's handle movements.

Solution:

The grass catcher and handle are linked, eliminating as much as possible the transfer of rough handle movements causing changes in the cutting section attitude. By adjusting the link rods, the handle can remain centered in the handle adjuster, and uniform cutting section contact pressure can be achieved.

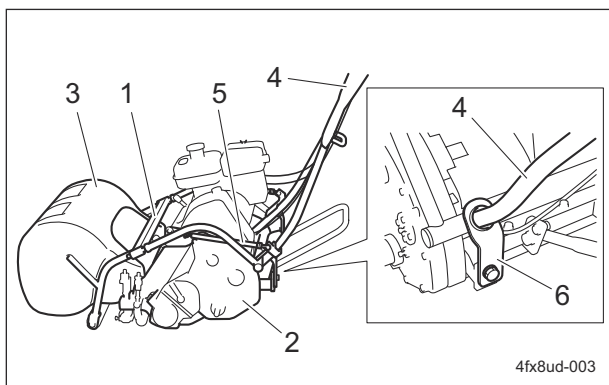

IGCA (Independent Grass Catcher Arm)_003

1	IGCA
2	Cutting section
3	Grass catcher
4	Handle
5	Link rod
6	Handle adjuster

Effect 1:

Regardless of skill level, any operator can mow at a uniform cutting height, as long as the handle can be adjusted within the range of the hole in the handle adjuster.

This is effective when accelerating very quickly or mowing undulations.

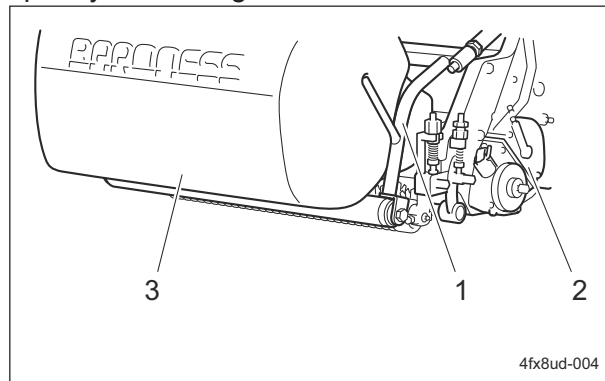

IGCA (Independent Grass Catcher Arm)_004

1	IGCA
2	Cutting section
3	Grass catcher

Effect 2:

Since the load of the grass catcher does not affect the front roller, it is possible to reduce sinking (gouging or digging) caused by the front roller touching the ground when entering the green.

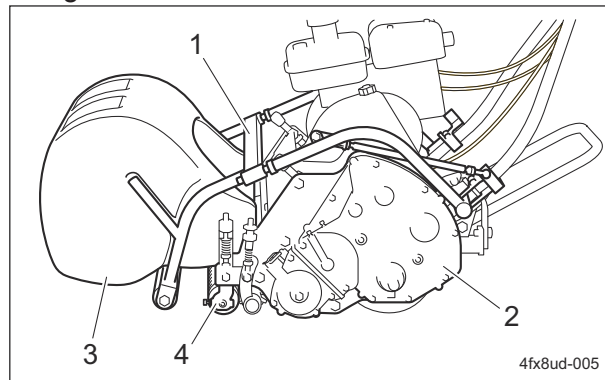

IGCA (Independent Grass Catcher Arm)_005

1	IGCA
2	Cutting section
3	Grass catcher
4	Front roller

Instruments

Hour Meter

Important

The battery of this hour meter can not be replaced.
 If the battery power is burned out, replace the hour meter with a new one.

The hour meter indicates the accumulated operation time of the engine.
 The accumulated time can not be manually reset.
 When the accumulated time exceeds 99999 hours, the display automatically shows zero for restart.

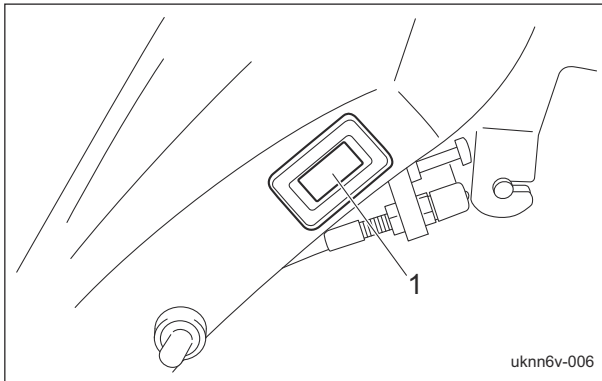

Hour Meter_001

1	Hour meter
---	------------

Description of Functions

Operations before Service Page 5-2

- Procedure to Open/Close Engine
- Clutch Cover Page 5-2

Preparation for Use Page 5-2

- Installation of The Handle Page 5-2
- Connection of Engine Switch Cord Page 5-2
- Installation of The Stand Page 5-3
- Confirmation of The Operation Page 5-3

Inspection before Use Page 5-3

- Engine Page 5-3
- Driving Section Page 5-6
- Cutting Section Page 5-6

Adjustment before Work Page 5-7

- Adjustment of Air Adjusting Plate Page 5-7

Start/Stop of Engine Page 5-8

- Procedure to Start Engine Page 5-8
- Procedure to Stop Engine Page 5-10

Parking and Stopping Page 5-10

- Procedure to Leave The Machine Page 5-10

Move Page 5-11

- Traveling Procedure Page 5-11

Cutting Work Page 5-11

- Cutting Procedure Page 5-11
- Procedure to Remove/Install
Traveling Tires Page 5-12
- Procedure to Remove/Install Grass
Catcher Page 5-13

Transporting Page 5-13

- Transporting Procedure Page 5-13

Cleaning after Use Page 5-13

- Engine Page 5-14
- Cutting Section Page 5-14

Storage Page 5-14

- Short-Term Storage Page 5-14

Handling Instructions

Operations before Service

The following sections describe the preparatory works required before performing the services including inspection, adjustment, cleaning, maintenance and repair.

Procedure to Open/Close Engine Clutch Cover

1. Procedure to open the engine clutch cover:

- [1] Remove the lock bolt.
- [2] Remove the engine clutch cover.

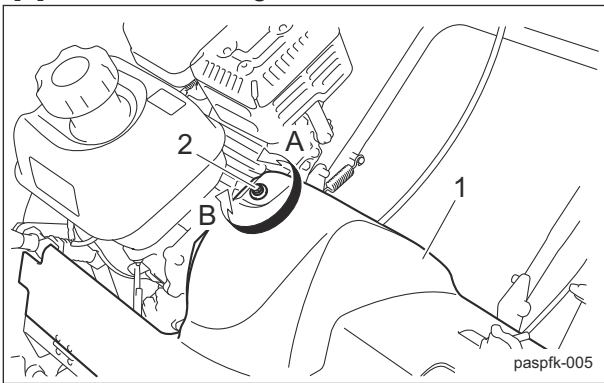

Procedure to Open/Close Engine Clutch Cover_001

1	Engine clutch cover
2	Lock bolt
A	Loosen
B	Tighten

2. Procedure to close the engine clutch cover:

- [1] Install the engine clutch cover.
- [2] Install the lock bolt.

Preparation for Use

Installation of The Handle

1. Put the handle pin on the left frame into the hole at the left-side lower edge of the handle.
2. While pressing the right-side lower edge of the handle inward, put the handle pin of the right frame into the hole.
3. Secure the lower edges (slotted section of the handle adjusters) of the right and left sides of the handle to the rear frame stay from the back with the bolts, conical spring washers, and washers.

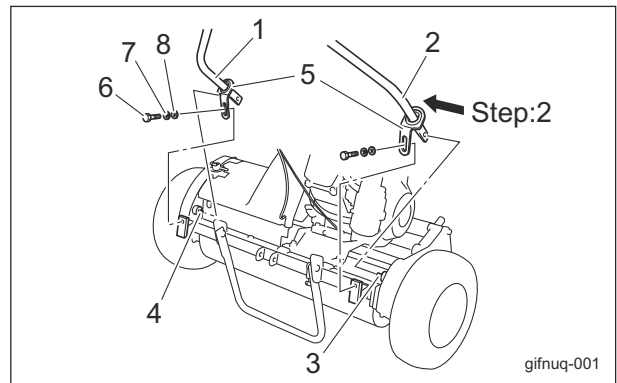

Installation of The Handle_001

1	Left-side lower edge of handle
2	Right-side lower edge of handle
3	Handle pin (Right frame)
4	Handle pin (Left frame)
5	Handle adjuster
6	Bolt
7	Conical spring washer
8	Washer

Connection of Engine Switch Cord

Important

When the connection of the engine switch cord is incomplete, the engine will not stop even if the engine switch is operated. Check that the cord is correctly connected.

When assembling the handle, check the connection of the engine switch cord. There are two connections - plug and crimp terminal.

1. The plug is connected to the plug connected to the engine.
2. The crimp terminal is secured to the engine crankcase with a hexagon bolt.

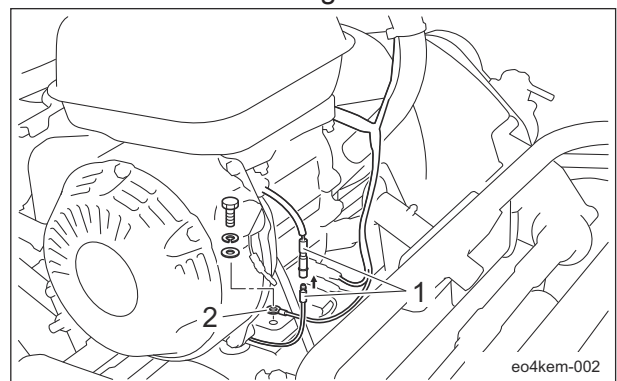

Connection of Engine Switch Cord_001

1	Plug
2	Crimp terminal

Handling Instructions

Installation of The Stand

1. With the inside projection side set to the right, temporarily secure the left side of the stand to the frame with the bolt, washer (inside), and nut (outside).
2. Put the spring on the projection of the frame and the projection at the right edge of the stand.

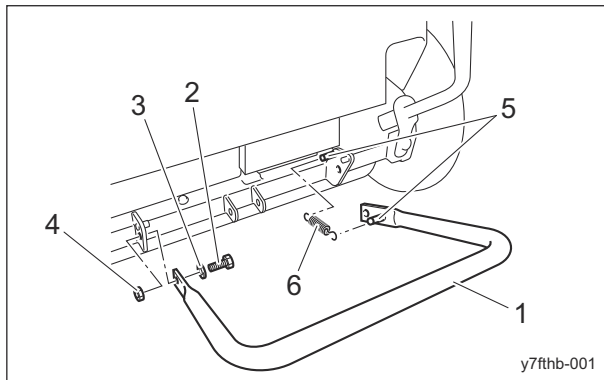

Installation of The Stand_001

1	Stand
2	Bolt
3	Washer
4	Nut
5	Projection
6	Spring

3. While pulling the right side of the stand backward, make alignment with the hole in the frame, and secure the stand with the bolt, washer (inside), and nut (outside).
4. Tighten the bolt, washer, and nut at the left side of the stand that were temporarily secured.

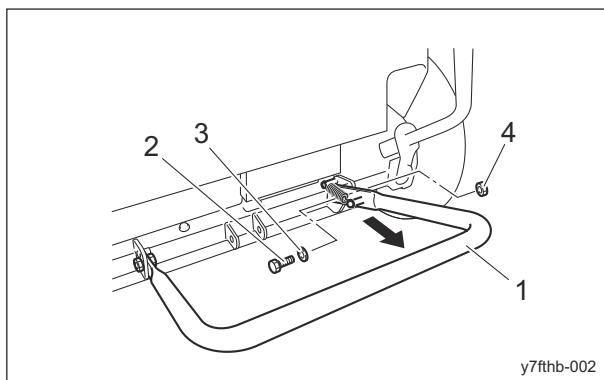

Installation of The Stand_002

1	Stand
2	Bolt
3	Washer
4	Nut

Confirmation of The Operation

1. Check that the brake operates completely.
2. Check that the engine clutch operates completely.
3. If necessary, make adjustment.

Inspection before Use

The purpose of the machine inspection is to:

- Prevent accidents
- Prevent damage to the machine
- Maintain machine performance

Detecting machine malfunctions early helps prevent unexpected problems from occurring. If you detect any abnormalities with the machine, immediately perform maintenance or repairs.

Engine

Inspection of Engine Oil

Important

When installing the oil level gauge, tighten it securely.

Check the contamination of oil and engine oil level to inspect the engine oil.

Inspect the engine oil level 10 to 20 minutes after stopping the engine.

1. Place the machine so that the engine is level.
2. Stop the engine.
3. Pull out the oil level gauge.

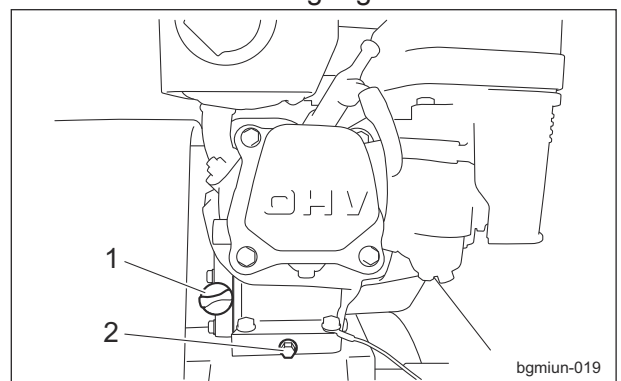

Inspection of Engine Oil_001

1	Oil level gauge (Oil filler port)
2	Drain plug

4. Wipe the oil off the oil level gauge cleanly with papers or cloths.

Handling Instructions

5. After wiping the oil off the oil level gauge, check the contamination.
6. Return the oil level gauge to its original position, and pull out again without tightening it.
7. Check the engine oil level.
The appropriate engine oil level should be between the upper and lower limit lines on the gauge.

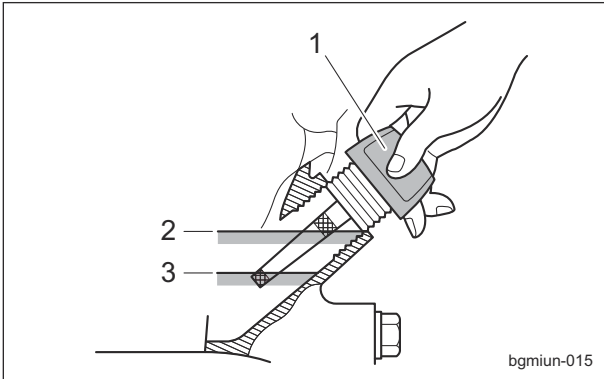

Inspection of Engine Oil_002

1	Oil level gauge
2	Upper limit
3	Lower limit

8. Return the oil level gauge to its original position, tighten it securely.

Inspection of Fuel Quantity

Level the machine and then remove the tank cap to inspect fuel quantity from the fill port.

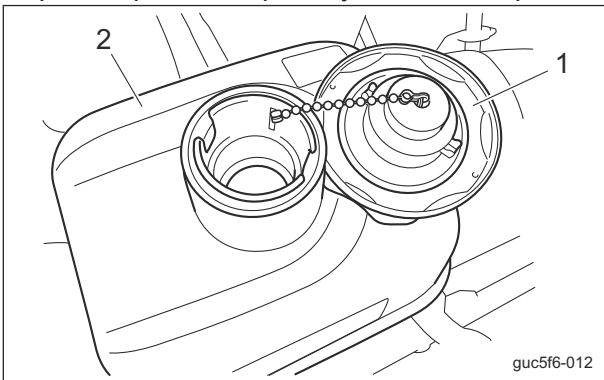

Inspection of Fuel Quantity_001

1	Tank cap
2	Fuel tank

Supply of Fuel

⚠ Caution

Do not supply fuel above FULL level of the fuel gauge.
If you supply too much fuel, it might overflow from the fuel cap when you travel or work on a slope.

⚠ Caution

Keep fire away while refueling.
Do not smoke while refueling.

⚠ Caution

Supply fuel after the engine is stopped and has well cooled down.

⚠ Caution

Pay attention not to touch hot parts.

Inspect the fuel quantity and put fuel (gasoline) if insufficient.
The fuel tank capacity is approximately 2.0 dm³ (2.0 L).

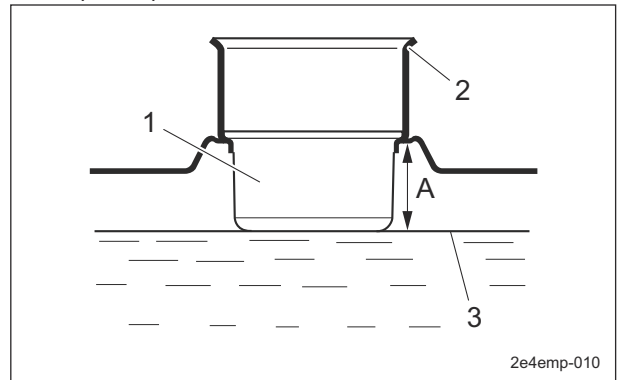

Supply of Fuel_001

1	Fuel strainer
2	Filling opening
3	Maximum limit of fueling
A	2.5 cm (0.98 in)

Inspection of Fuel Strainer

1. Make sure that there is no fuel leakage.
2. Make sure that the fuel strainer is not damaged or dirty.

Handling Instructions

Inspection of Liquid Leakage

Important

After approximately 50 hours of operation, some tightened portions may be loosened and liquid such as oil may leak. Be sure to retighten the parts.

Important

If liquid leakage found, repair it before operation. Ignoring leakage will cause further trouble.

1. Check the bottom of the machine for leakage of liquid such as oil, water, etc.
2. Locate the leakage and identify the type of liquid.

Inspection of Air Cleaner

The air cleaner is a component that removes dirt from the intake air to prevent wear of the cylinder liners and piston rings so that the engine will always operate smoothly. A contaminated air cleaner element may cause malfunction of the engine.

1. Make sure that there is no damage to the air cleaner.
2. Make sure that the air cleaner element is not contaminated.

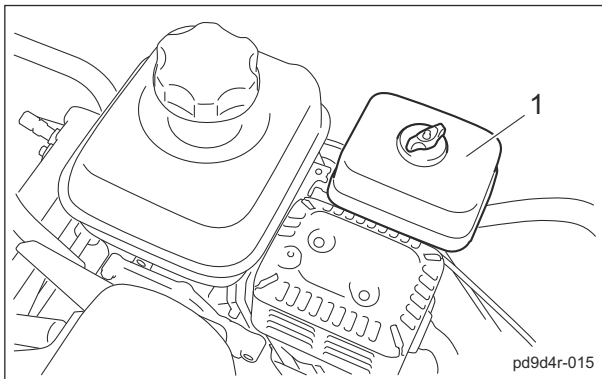

Inspection of Air Cleaner_001

1	Air cleaner
---	-------------

Inspection of Bolts and Nuts

Important

The bolts and nuts may be loosened at the earlier stage of the use. Be sure to retighten or replace before operating the machine whenever there is any abnormality.

1. Check the bolts and nuts for looseness and coming off.
2. Check the bolts and nuts for cracks and damages.
3. Check the bolts and nuts for rust.
4. Check around the bolts and nuts for traces of rust fluid.
5. Check for unequal bolt length.
6. Check the bolts and nuts for stripped threads and abrasion.

Inspection of Engine-Associated Parts

Caution

Perform operations after the muffler, engine and other parts have sufficiently cooled. Otherwise, you may get burned.

1. Check for damages and dirt.
2. Check the mount for looseness and cracks.
3. Check for liquid leakage.
4. Check on and around the muffler for grass clippings and flammable materials.

Handling Instructions

Driving Section

Inspection of Tires

1. Make sure that there are no cracks, damage or abnormal wear.
2. Check the pneumatic pressure of the tires.

	Tire size	Pneumatic pressure	
Tire for traveling	4.10/3.50-6	120 kPa (1.2 kgf/cm ²)	17 psi

Inspection of Clutch Lever

1. Make sure that there is no play in the lever.
2. Make sure that the lever moves smoothly.
3. Make sure that there is no abnormal sound when the lever is moved.

Inspection of Clutch Lock Lever

1. Make sure that there is no play in the clutch lock lever.
2. Make sure that the clutch lock lever moves smoothly.
3. Make sure that the main clutch lever is not in the "ON" position when the clutch lock lever is tilted to the "LOCK" side.
4. Make sure that you can fully grip the main clutch lever when the clutch lock lever is tilted to the "UNLOCK" side.

Inspection of Covers

Warning

If you have removed the cover during inspection, make sure that you replace it in the original position securely. If the cover remains removed, the operator or the mechanic may come in contact with the rotating objects or belt, or foreign objects may fly off, possibly resulting in injuries.

1. Make sure that there is no wear or deterioration of covers.
2. Make sure that there is no damage to covers.
3. Make sure that there is no interference with moving parts due to deformation of covers.
4. Make sure that covers are installed in their appropriate positions.

Inspection of Brake

1. Grip the brake lever and make sure that the brake can operate completely.
2. Operate the lock lever and make sure that it can lock the brake lever.
3. Make sure that the brake is not applied even slightly after releasing the lock on the brake lever.

Inspection of Wire

1. Make sure that the wire is not cracked or damaged.
2. Make sure that the wire is not worn.
3. Make sure that the wire is not crushed.
4. Make sure that the wire is not bent.
5. Make sure that the wire is not corroded or rusted.

Cutting Section

Inspection of Reel Cutter (Cutting Cylinder) and Bed Knife (Bottom Blade)

Caution

Wear gloves when touching edged tools to avoid cutting your hands.

1. Check to see whether or not the edge of the reel cutter (cutting cylinder) and the bed knife (bottom blade) are too blunt to cut.
2. Make sure that the reel cutter (cutting cylinder) and the bed knife (bottom blade) are not cracked.
3. Check to see how much the reel cutter (cutting cylinder) and the bed knife (bottom blade) are worn.
4. Make sure that the reel cutter (cutting cylinder) and the bed knife (bottom blade) have not changed color due to heat from grinding.
5. Check to see whether or not the second edge face (relief) remains at the point of reel cutter (cutting cylinder).
6. Make sure that the welding between the reel cutter (cutting cylinder) and the disc has not come off.

Handling Instructions

Inspection of Covers

Warning

If you have removed the covers during inspection, be sure to securely install them in their original positions.

If a cover remains removed, the operator or the mechanic may come into contact with rotating parts or belts and foreign objects may fly off, possibly resulting in injuries.

1. Make sure that there is no wear or deterioration of the reel cover and all other covers.
2. Make sure that there is no damage to the reel cover and all other covers.
3. Make sure that there is no interference with moving parts due to deformation of the reel cover and all other covers.
4. Make sure that the reel cover and all other covers are installed in their appropriate positions.

Inspection of Rollers

1. Make sure that there is no abrasion nor adhesion of the roller.
2. Make sure that there is no wear of the roller shaft.
3. Make sure that there is no wear nor damage of the oil seal.
4. Make sure that there is no wear nor rust of the bearing.
5. Make sure that there is no play in the roller shaft.

Inspection of Drum

1. Make sure that the drum is not cracked or damaged.
2. Make sure that there is no abrasion or adhesion of the drum.
3. Make sure that there is no play in the fit of the drum and the bearing.

Inspection of Groomer

Note:

Depending on the specifications, this function may not be available.

Caution

Wear gloves when touching edged tools to avoid cutting your hands.

1. Make sure that the vertical blades are not cracked.
2. Check how much the vertical blades are worn.
3. Make sure that the shaft is not worn nor bent.
4. Make sure that there is no wear nor rust of the bearing.
5. Make sure that there is no play in the groomer shaft.

Inspection of Grass Catcher

1. Make sure that there is no wear or deterioration of the grass catcher.
2. Make sure that there is no damage to the grass catcher.
3. Make sure that there is no interference to moving parts due to deformation of the grass catcher.

Adjustment before Work

Adjustment of Air Adjusting Plate

Caution

The air adjusting plate should be operated while the engine rotation is stopped, and adjusted to the position suitable for your work.

The air adjusting plate is attached on the reel cover of the mower unit and it adjusts the dispersing angle of clippings.

Adjust the air adjusting plate according to the grass condition.

Push in the spring to slide the air adjusting plate.

1. Move the air adjusting plate closer to the reel cutter when the lawn condition is dry.
2. Move the air adjusting plate away from the reel cutter when the lawn condition is wet.

Handling Instructions

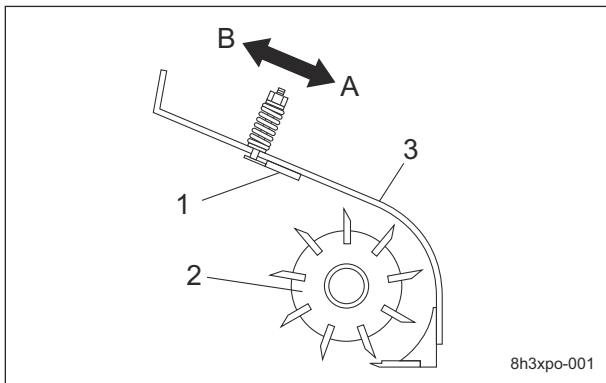

Adjustment of Air Adjusting Plate_001

1	Air adjusting plate
2	Reel cutter
3	Reel cover
A	Close
B	Away

2. Make sure that the brake is locked.

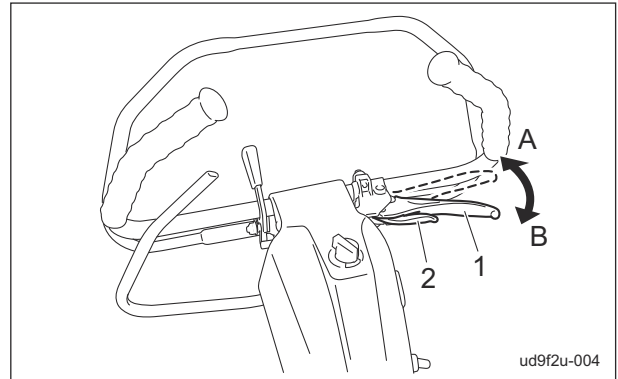

Procedure to Start Engine_002

1	Brake lever
2	Lock lever
A	Lock
B	Unlock

Start/Stop of Engine

Procedure to Start Engine

⚠ Caution

Before starting the engine, make sure that there are no other people or obstacles around the machine.

⚠ Caution

Make sure that the engine clutch cover is installed in the prescribed position.

1. Make sure that the engine switch is in the "OFF" position.

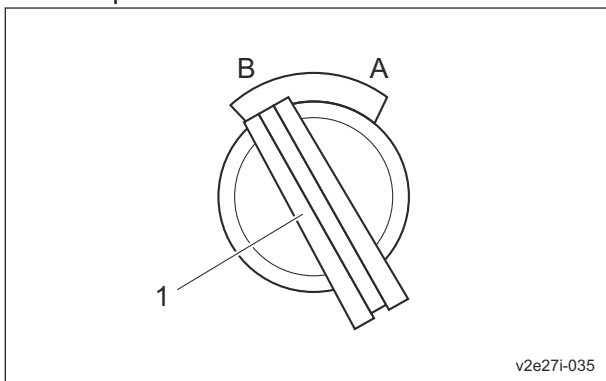

Procedure to Start Engine_001

1	Engine switch
A	ON
B	OFF

3. Don't grip the main clutch lever.

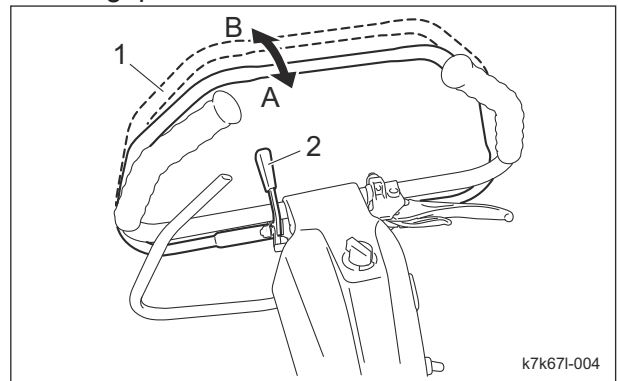

Procedure to Start Engine_003

1	Main clutch lever
2	Clutch lock lever
A	ON
B	OFF

4. Set the fuel cock to the "Open" position.

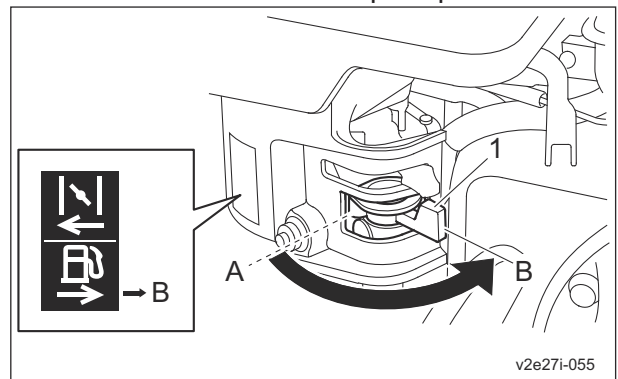

Procedure to Start Engine_004

1	Fuel cock
A	Close
B	Open

5. Set the engine switch to the "ON" position.

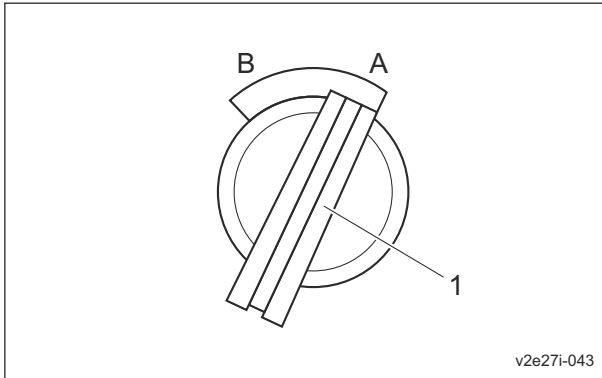

Procedure to Start Engine_005

1	Engine switch
A	ON
B	OFF

6. Set the choke lever to the "Close" position.

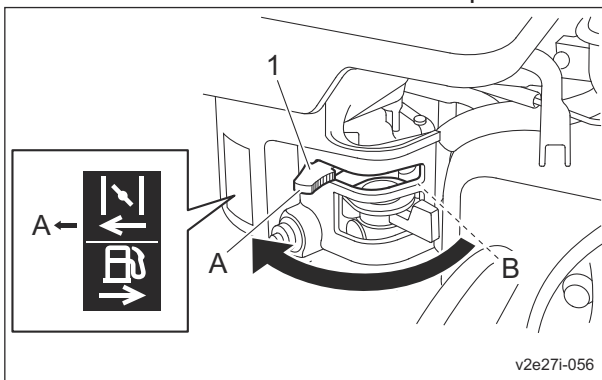

Procedure to Start Engine_006

1	Choke lever
A	Close
B	Open

Important

Return the starter grip slowly to its original position after the engine starts.
 Do not let go of the pulled starter grip since it may cause damage to the machine.

7. Pull the starter grip swiftly, and the engine will start.

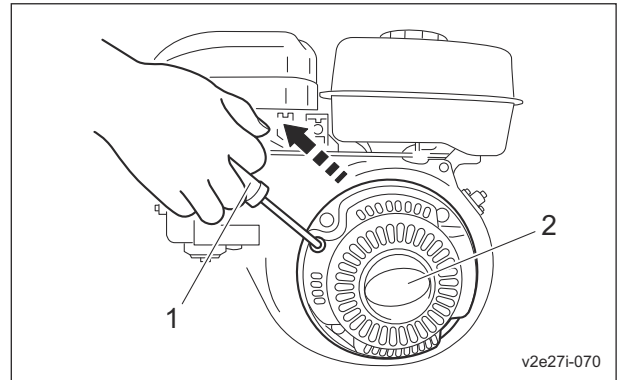

Procedure to Start Engine_007

1	Starter grip
2	Recoil starter

8. Set the choke lever to the "Open" position.

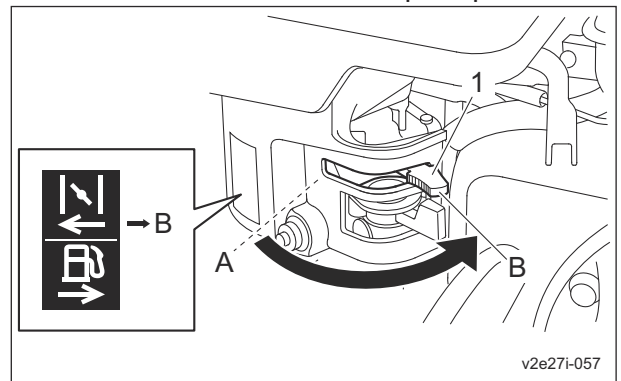

Procedure to Start Engine_008

1	Choke lever
A	Close
B	Open

Handling Instructions

Procedure to Stop Engine

1. Don't grip the main clutch lever.

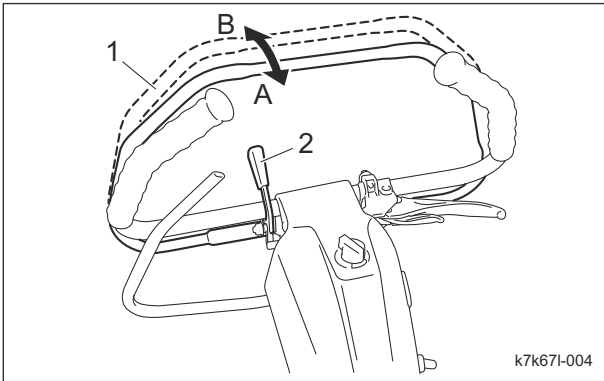

Procedure to Stop Engine_001

1	Main clutch lever
2	Clutch lock lever
A	ON
B	OFF

2. Grip the lock lever while gripping the brake lever to lock the brake.

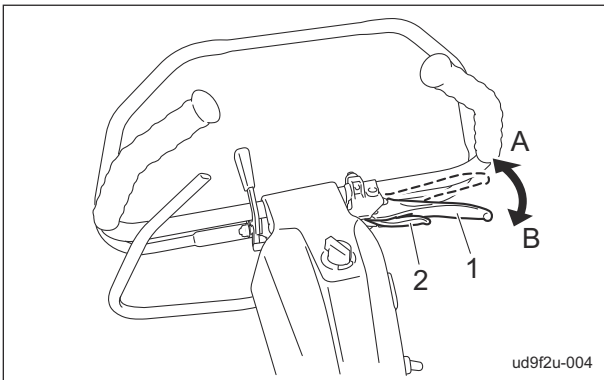

Procedure to Stop Engine_002

1	Brake lever
2	Lock lever
A	Lock
B	Unlock

3. Set the engine switch to the "OFF" position.

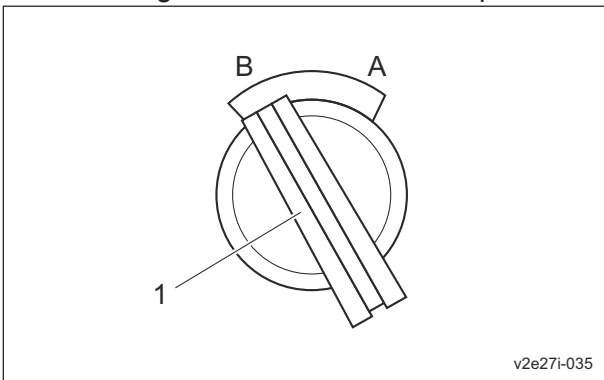

Procedure to Stop Engine_003

1	Engine switch
A	ON
B	OFF

4. Make sure that the engine has stopped.

5. Set the fuel cock to the "Close" position.

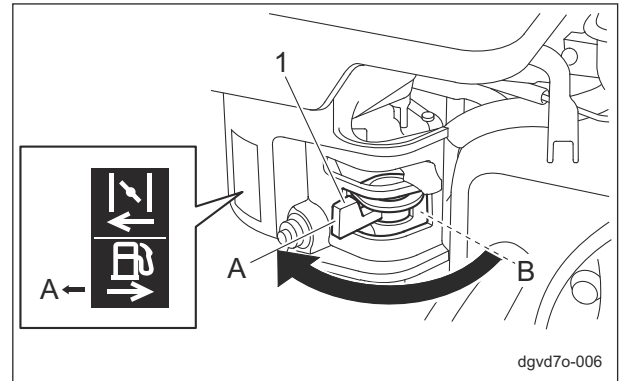

Procedure to Stop Engine_004

1	Fuel cock
A	Close
B	Open

Parking and Stopping

Procedure to Leave The Machine

⚠ Caution

If the brakes are not sufficiently effective, use the wheel stoppers to secure the machine.

⚠ Caution

Do not park the machine on a slope.

⚠ Caution

Check that the engine has stopped.

1. Stop the machine on a flat place.
2. Make sure that the brake lever is locked.
3. Stop the engine.
4. Set the fuel cock to the "Close" position.
5. Leave the machine.

Handling Instructions

Move

Traveling Procedure

Caution

Under any circumstances drive the machine at such a speed that you can stop it immediately for emergencies.

Caution

Do not start to move or stop the machine abruptly.

1. Install traveling tires.
2. Flip up the stand.
3. Set the traveling/working selector lever to "Travel ON" position of.
4. Start the engine.
5. Release the brake.
6. Release the safety lock and grip the main clutch lever slowly.
7. The machine starts traveling.
8. The machine stops when the main clutch lever released.

Cutting Work

Cutting Procedure

Warning

Do not operate on a steep slope.

Caution

Do not start to move or stop the machine abruptly.

Caution

Be sure to operate at an appropriate speed for the mowing site.

For mowing on an undulated surface, mow with lowered cutting speed.

Important

Be sure to attach the grass catcher. Discharge the clippings at the right time during operation.

1. Remove the traveling tires.

2. Flip up the stand.
 3. Install the grass catcher.
 4. Move the air adjusting plate to the desired position.
 5. Move the groomer clutch lever to the desired position.
 6. Make the traveling/working selector lever to the "Reel ON" position.
 7. Start the engine.
 8. Release the brake.
 9. Release the safety lock and grip the main clutch lever slowly to start mowing.
- Note:
Operate at about 3,000 rpm.

Handling Instructions

Procedure to Remove/Install Traveling Tires

Important

Mow with the traveling tires removed.

Use the traveling tires to move the machine by self-propelling.

Removal of traveling tires:

1. Set the machine on its stand.

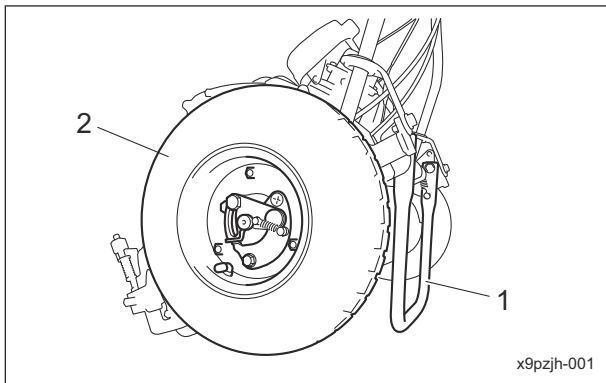

Procedure to Remove/Install Traveling Tires_001

1	Stand
2	Traveling tires

2. While sliding the lever of the wheel mounting plate and holding it in the released position, pull the traveling tire toward you to remove it.

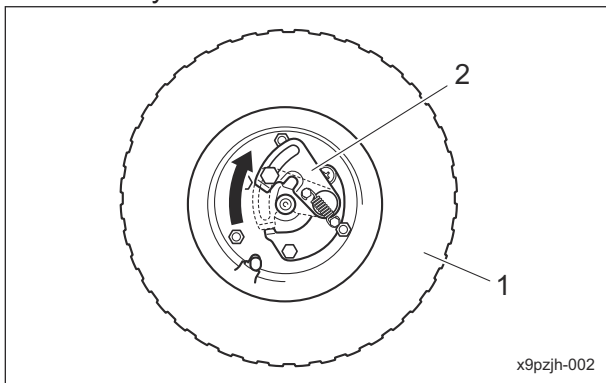

Procedure to Remove/Install Traveling Tires_002

1	Traveling tires
2	Wheel mounting plate

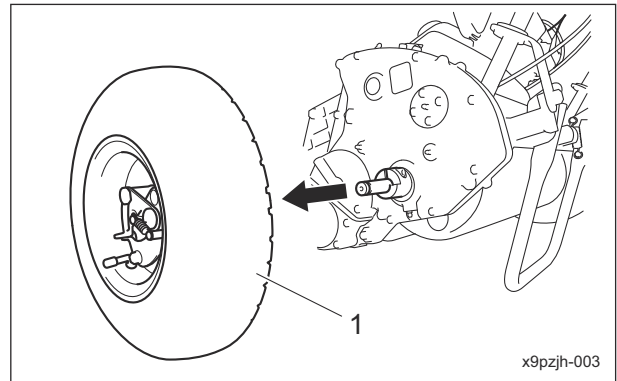

Procedure to Remove/Install Traveling Tires_003

1	Traveling tires
---	-----------------

3. Follow the same steps to remove the traveling tire on the opposite side.

Installation of traveling tires:

Follow below steps to install the traveling tire.

1. Set the machine on its stand.

Important

The drum shaft and traveling tire have depressions and projections that fit together. Match the shapes during installation.

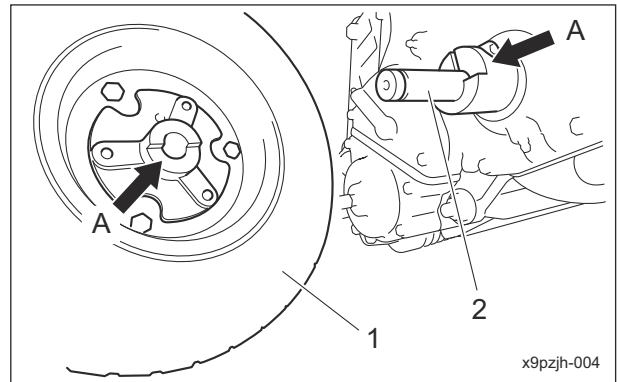

Procedure to Remove/Install Traveling Tires_004

1	Traveling tires
2	Drum shaft
A	Depressions and projections that fit together

Handling Instructions

2. Install the traveling tire to the drum shaft.

Important

Make sure that the wheel mounting plate fits into the groove in the drum shaft. If they do not engage, the wheel may fall off.

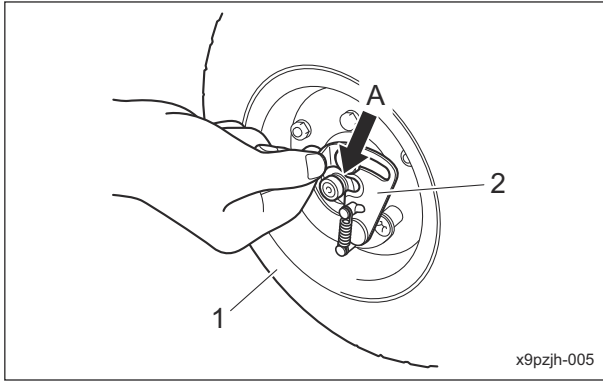

Procedure to Remove/Install Traveling Tires_005

1	Traveling tires
2	Wheel mounting plate
A	Groove

Procedure to Remove/Install Grass Catcher

Caution

Stop the engine before removing / installing the grass catcher.

Removing Grass Catcher:

Lift up the grass catcher to detach the right & left latches of it from the roller brackets.

Installing Grass Catcher:

Attach the right & left latches of the grass catcher to the roller brackets.

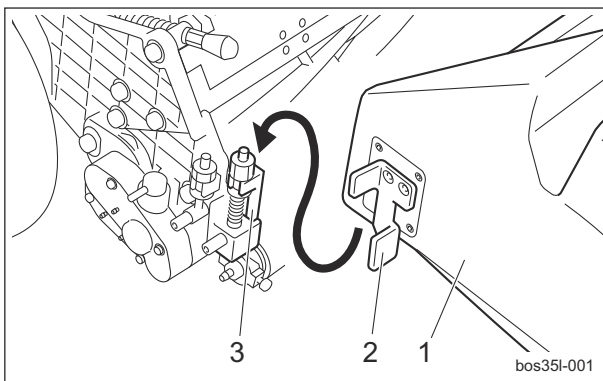

Procedure to Remove/Install Grass Catcher_001

1	Basket
2	Latch
3	Roller bracket

Transporting

Transporting Procedure

Caution

When loading and unloading the machine, wear non-slip shoes and travel slowly.

Important

When securing the machine with a rope, do not tie the rope to the engine.

Important

When securing the machine with a rope, be careful not to bend any wires.

Be extremely careful when loading the machine into a truck or a trailer. Before loading or unloading, stop the truck or trailer on a level surface in a safe location, apply the parking brake, stop the engine, and then chock the wheels. Before loading into a truck or a trailer for transportation, apply the parking brake of the machine, stop its engine, and then secure the machine with rope or any other sufficiently strong restraining device. When using a loading ramp, select one of sufficient length, width and strength, and that will not allow the machine to slip off.

Cleaning after Use

The purpose of the machine cleaning is to:

- Prevent accidents
- Prevent damage to the machine
- Maintain machine performance

Properly clean the machine to maintain its functionality and performance.

If you detect any abnormalities with the machine, immediately perform maintenance or repairs.

Handling Instructions

Engine

Cleaning of Engine-Associated Parts

⚠ Caution

Perform operations after the muffler, engine and other parts have sufficiently cooled. Otherwise, you may get burned.

1. Clean clippings and remove dirt.
2. Blow compressed air to clean any grass or flammable materials that may be attached on or around the muffler.

Cutting Section

Cleaning of Cutting Section

Important

While cleaning, do not allow water on the sealed parts of the reel shaft. (Avoid high-pressure water cleaning.) Otherwise, it may cause damage to the machine.

- Be sure to clean the cutting section after use.
1. Stop the engine, and then remove the key.
 2. Carefully clean the front and back of the cutting section with water or compressed air.
 3. Remove any grass wrapped around the reel cutter (cutting cylinder).

Storage

Short-Term Storage

Short-term storage means that the machine is temporarily stored (within 1 month) without use.

Follow the instructions below for short-term storage of the machine.

1. Cleaning
 - Remove dirt, grass clippings, oil stains etc. completely from the main vehicle and engine.
2. Storage location
 - Cover the machine and store it in a dry place where it will not be exposed to rain.

Precautions for Maintenance	Page 6-2
Position of Mower during Maintenance	Page 6-2
Inspection and Cleaning	Page 6-2
Engine	Page 6-2
Driving Section	Page 6-3
Supplying Fluids	Page 6-4
Engine	Page 6-4
Greasing	Page 6-4
About Greasing	Page 6-4
Greasing Points	Page 6-5
Lubrication	Page 6-7
About Lubrication	Page 6-7
Lubricating Points	Page 6-7
Adjustment	Page 6-8
Driving Section	Page 6-8
Cutting Section	Page 6-8
Replacement	Page 6-19
Engine	Page 6-19
Cutting Section	Page 6-20
Storage	Page 6-29
Long-Term Storage	Page 6-29

Maintenance

Precautions for Maintenance

Warning

The chapter "Maintenance" in this manual describes practical measures which should be performed by a mechanic with expertise. The owner should instruct the mechanic with expertise to perform maintenance service for this machine.

Caution

First, learn well the operations you plan to perform.

Important

Use tools appropriate for each operation.

Important

Use Baronsess genuine parts for replacement and accessories. Our product warranty may be void if you use non-genuine parts for replacement or accessories.

Position of Mower during Maintenance

Important

If the mower is left for a long time during maintenance with the handle leaned on the ground or with the handle hoisted up, the engine oil will enter the engine combustion chamber and cause the engine to run improperly. After leveling the engine, be sure to start the engine in ten minutes to ensure sufficient time for any oil to drain back.

Inspection and Cleaning

Inspect and clean the machine with the goals of the followings.

- Accident prevention
- Failure prevention
- Performance retention

Make efforts for early detection of the machine failure and prevention of the sudden occurrence of trouble.

Perform maintenance and repair works immediately if any abnormality is found in the machine.

Engine

Cleaning of Fuel Strainer

If dust or dirt accumulates in the fuel strainer, the fuel flow will become insufficient. Periodically clean it.

Important

Clean the fuel strainer in a clean location, free of dust and dirt.

1. Close the fuel cock of the fuel strainer.
2. Remove the strainer cup.
3. Clean the filter and the inside of the strainer cup with a solvent, such as hardly flammable kerosene.
4. Dry with compressed air.

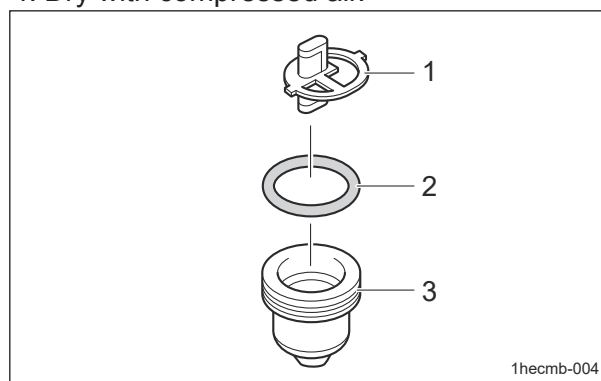

Cleaning of Fuel Strainer_001

1	Filter
2	O ring
3	Strainer cup

Important

During installation, prevent contamination with dirt or dust.

If the fuel is contaminated with dirt, dust, etc., the fuel flow will become insufficient.

5. Correctly install all parts in their original positions.
6. Fill up the fuel tank with fuel, and then open the fuel cock.
7. Make sure that there is no fuel leakage.

Cleaning of Air Cleaner Element

A contaminated air cleaner elements may cause malfunction of the engine. To maximize the life of the engine, clean the air cleaner properly.

1. Remove the wing screw, and then remove the cover.
2. Remove the screw, and then remove the air cleaner elements.
3. Remove the urethane element from the paper element.

Important

When cleaning the paper element, do not use petroleum solvents.

Important

Replace the air cleaner elements when it gets damaged or dirty.

4. Clean the urethane element with a solvent, such as a hardly flammable kerosene, and then soak it in the engine oil and wring out.
5. Remove dirt and dust from the paper element with blowing air or patting.
6. Assemble the paper and urethane elements.
7. Attach the air cleaner elements with the screw.

8. Set the cover, and then secure it firmly with the wing screw.

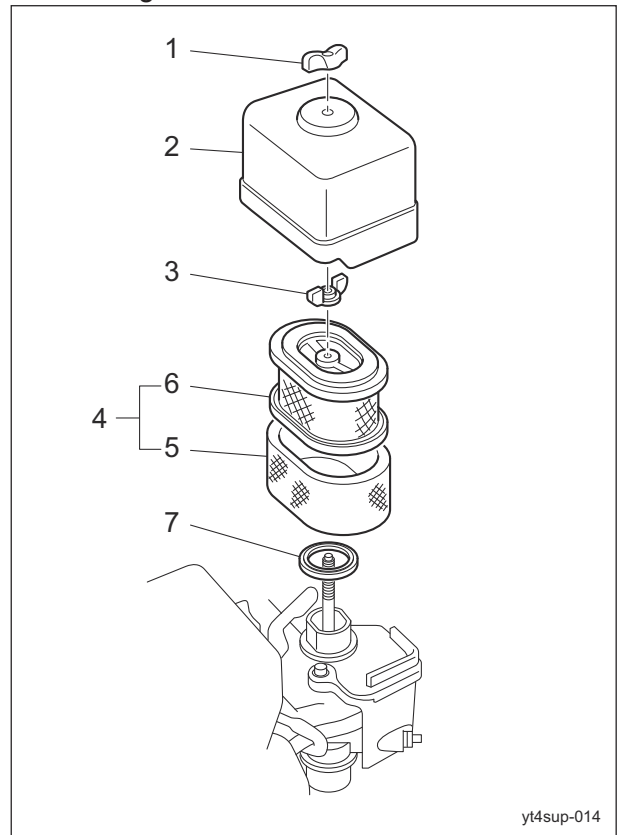

yt4sup-014

Cleaning of Air Cleaner Element_001

1	Wing screw
2	Cover
3	Screw
4	Air cleaner element
5	Urethane element
6	Paper element
7	Gasket

Driving Section**Inspection of Electrical Wiring****Important**

Electrical short circuit will cause fire, electrical leakage and malfunction of electrical equipments.

1. Make sure that there is no defacement in wires and terminals.
2. Make sure that there is no deterioration or damage in wires and terminals.
3. Make sure that there is no looseness in wiring connections.
4. Make sure that there is no poor terminal connection.

Maintenance

Supplying Fluids

Engine

Supply of Engine Oil

Important
Do not supply too much engine oil. Otherwise, the engine may be damaged.

Important
Do not mix different types of engine oil.

Important
Be sure to use engine oil that is classified as API Service Grade SE or higher, with an SAE Viscosity that is appropriate for the operating environment (ambient temperature).

Important
When installing the oil level gauge, tighten it securely.

If the engine oil level is lower than the lower limit line on the oil level gauge, supply engine oil.

Supply engine oil through the oil filler port.

1. Place the machine so that the engine is level.
2. Stop the engine.
3. Remove the oil level gauge.

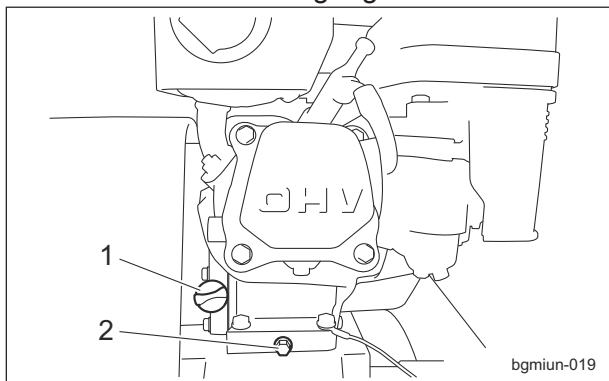

Supply of Engine Oil_001

1	Oil level gauge (Oil filler port)
2	Drain plug

4. Supply new engine oil through the oil filler port.

Supply oil until it reaches a level in the upper limit line on the oil level gauge.

5. Check the engine oil level without tightening the oil level gauge into the oil filler port.

6. Tighten the oil level gauge firmly.

Greasing

About Greasing

Since there may be adhesion or damage due to lack of grease on moving parts, they must be greased.

Add urea-based No. 2 grease in accordance with the Maintenance Schedule.

Other locations where the specified grease or lubricant is used are indicated in "Greasing Points".

Add grease using the specified grease or lubricant.

Greasing Points

Grease nipples are installed in the following locations.

Add grease to A every 10 hours, and B every 50 hours.

If specified locations and periods are additionally described below, follow the instructions.

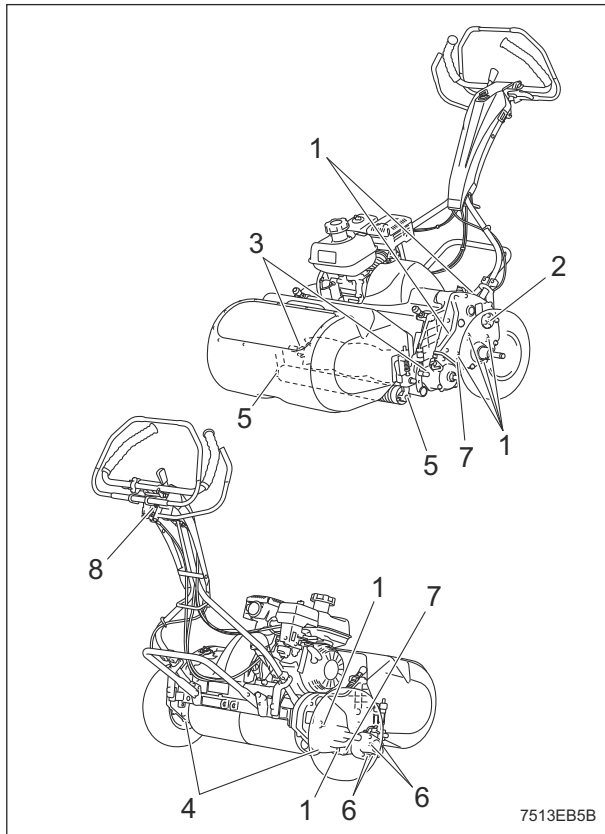

Greasing Points_001

	Location	No. of greasing points	Greasing period	
			A	B
1	Frame & Transmission	7	A	B
2	Differential gear	1	A	-
3	Reel bearing	2	-	B
4	Drum housing	2	-	B
5	Front roller	2	-	B
6	Groomer	4	A	B
7	Cam bush	2	Refer to "Maintenance Schedule."	
8	Handle	1	-	B

1. Frame & Transmission

There are seven points in total on the left and right.

Right side

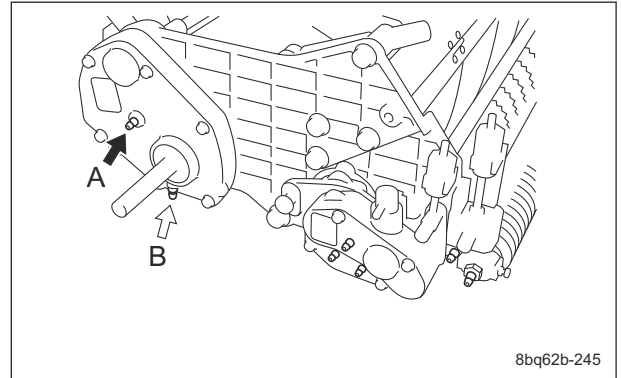

8bq62b-245

Greasing Points_002

Left side

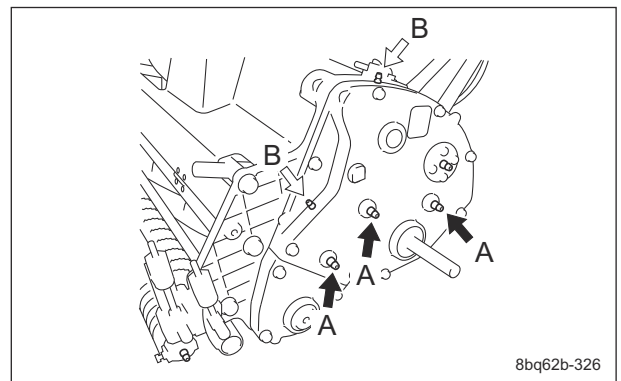

8bq62b-326

Greasing Points_003

2. Differential gear

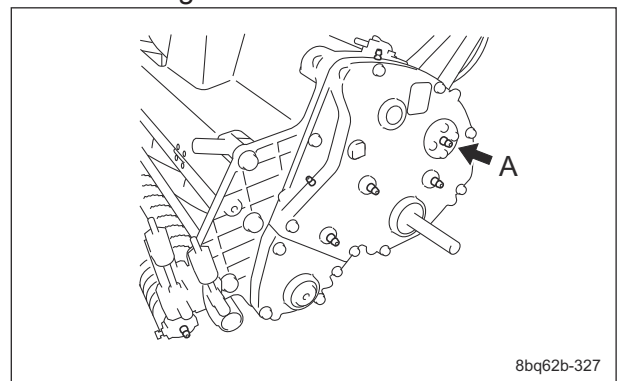

8bq62b-327

Greasing Points_004

Maintenance

3. Reel bearing

Before the initial greasing, remove the elastic adhesive on the tips of the grease nipples with a flat-blade screwdriver, etc.

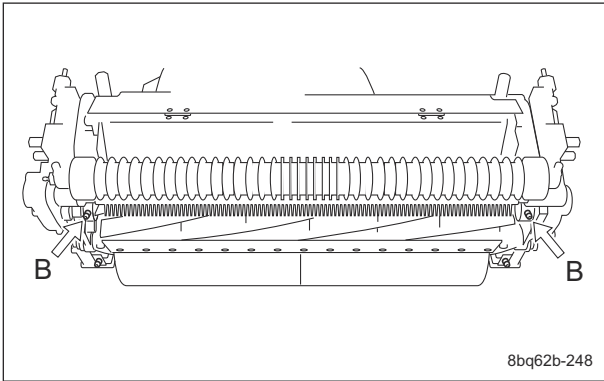

Greasing Points_005

4. Drum housing

Before the initial greasing, remove the elastic adhesive on the tips of the grease nipples with a flat-blade screwdriver, etc.

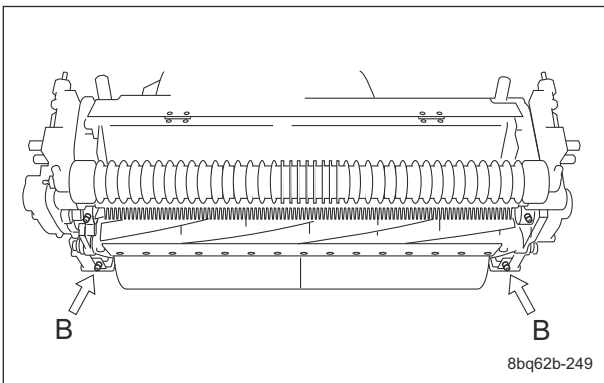

Greasing Points_006

5. Front roller

There is one point each on the left and right.
Right side

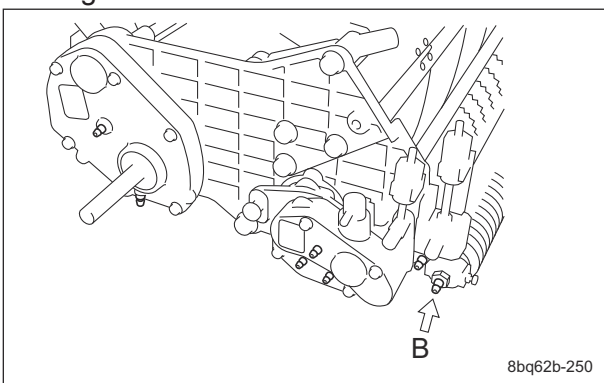

Greasing Points_007

Left side

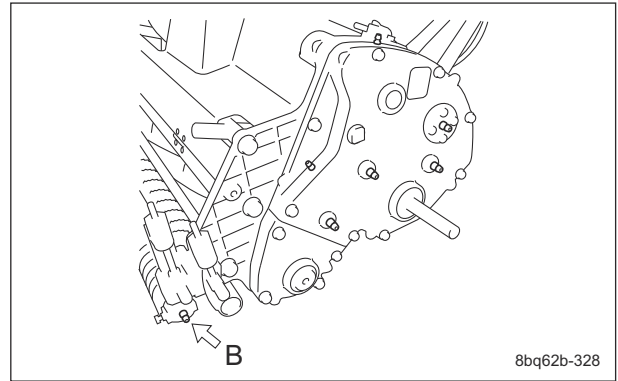

Greasing Points_008

6. Groomer

Note:

Depending on the specifications, this function may not be available.

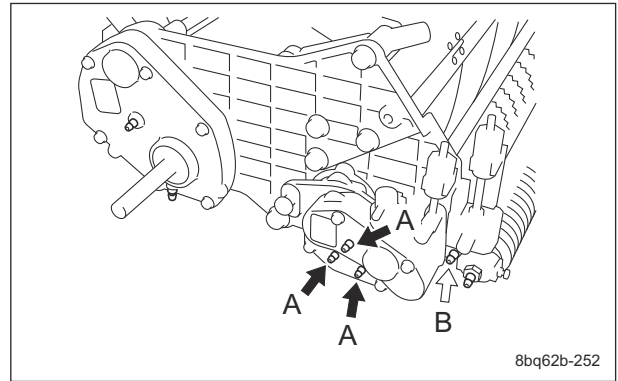

Greasing Points_009

7. Cam bush

There is one point each on the right and left sides.

Apply 0.5 g (0.001 lb) of grease to outer perimeter of the cam bush pipe according to the maintenance schedule.

Left side

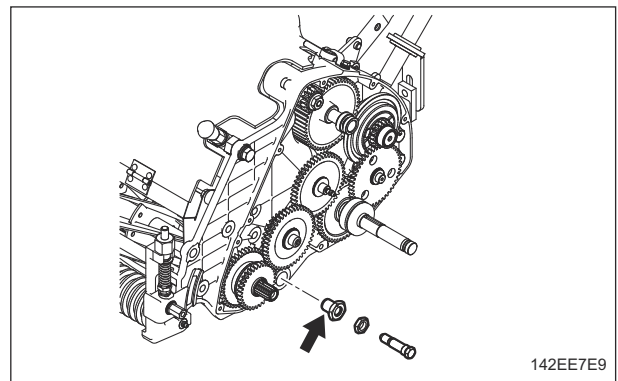

142EE7E9

Right side

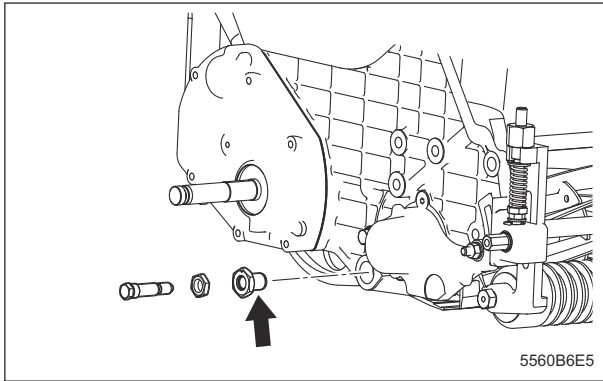

8. Handle
· Main clutch lever

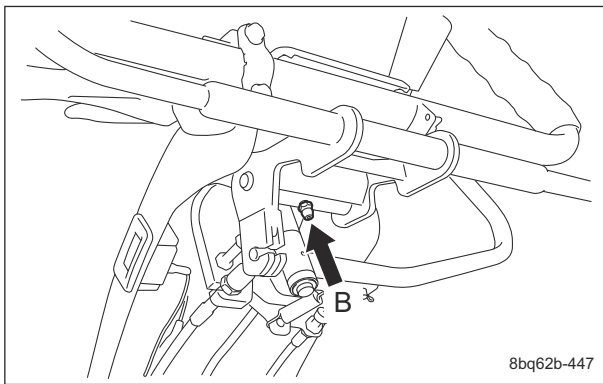

Greasing Points_010

Lubrication

About Lubrication

It is necessary to lubricate moving parts so that they will not become stuck or damaged. The locations where lubricant is used are indicated in "Lubricating Points". Apply the lubricant.

Lubricating Points

There are oil filling ports at the following locations.
Apply lubricant every 50 hours of operation.

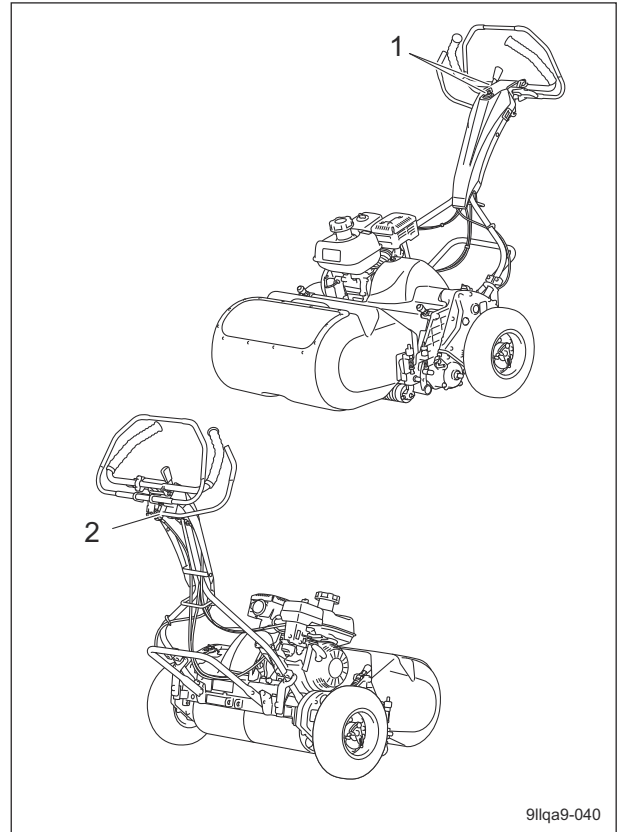

Lubricating Points_001

	Location	No. of greasing points
1	Clutch lock lever fulcrum	2
2	Throttle lever fulcrum	1

1. Clutch lock lever fulcrum

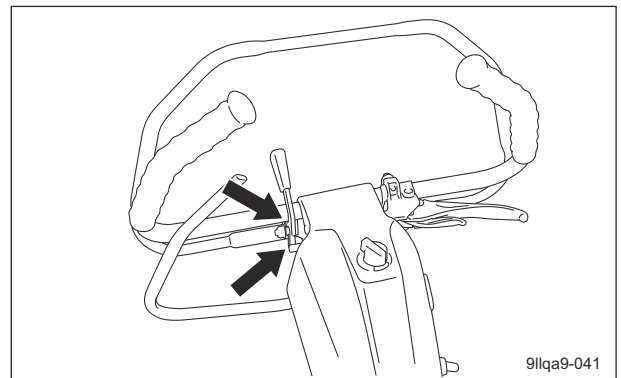

Lubricating Points_002

Maintenance

2. Throttle lever fulcrum

Note:

Depending on the specifications, this function may not be available.

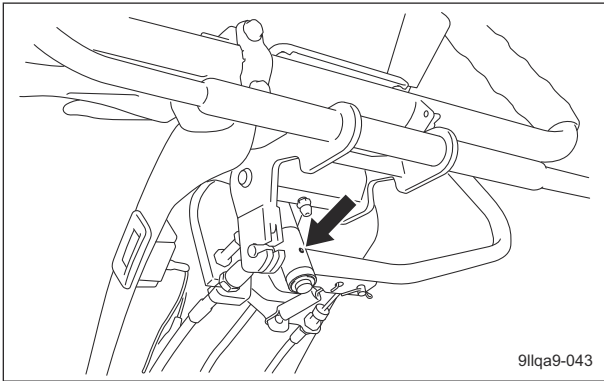

Lubricating Points_003

Adjustment

Driving Section

Adjustment of Handle Position

The height of the handle can be adjusted according to the operator's working position. Move the handle adjusters supporting the handle up or down and fix them with the bolts.

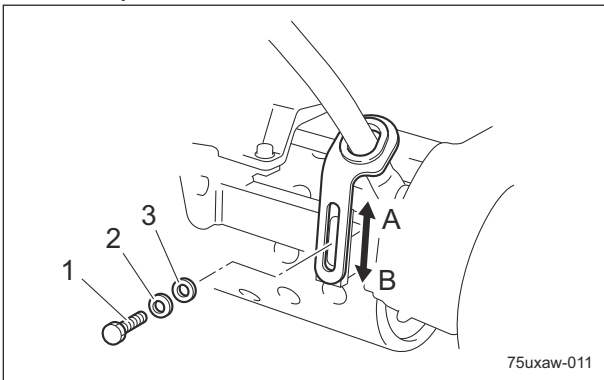

Adjustment of Handle Position_001

1	Bolt
2	Conical spring washer
3	Washer
A	High
B	Low

Cutting Section

Adjustment of Blade Engagement

Caution

When handling the reel cutter (cutting cylinder) or bed knife (bottom blade), wear gloves to protect your hands. Pay attention not to let the reel cutter (cutting cylinder) catch your gloves. Otherwise, you may injure your hand or fingers.

1. Stop the engine.
2. Set the traveling/working selector lever to the "Travel OFF" position.

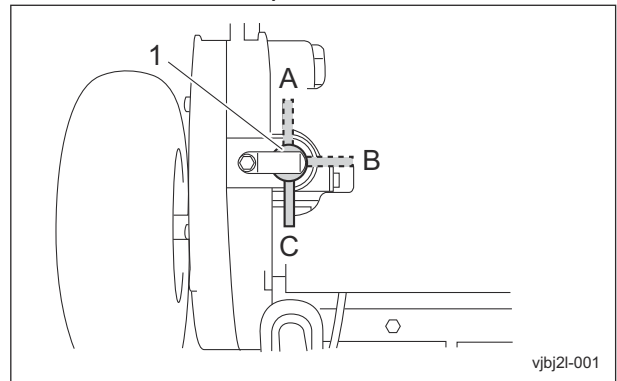

Adjustment of Blade Engagement_001

1	Traveling/Working selector lever
A	Reel ON
B	Travel ON
C	Travel OFF

3. With the cutter adjustment nut, adjust the engagement between the reel cutter (cutting cylinder) and the bed knife (bottom blade) so that a strip of Takumi Paper (Baroness genuine paper strips) or newspaper will be cleanly cut by the edge of both blades when the blades in their entirety come slightly into contact with each other.

4. Insert a strip of Takumi Paper or newspaper into the space between the reel cutter (cutting cylinder) and the bed knife (bottom blade) at an angle of 90 degrees. Then, rotate the reel cutter (cutting cylinder) counter-clockwise (when you face the mower unit from the left) to check the sharpness of the blades.

Check the sharpness of the entire range (at three or four points) of the reel cutter (cutting cylinder).

- If there is a gap between the blade edges:

Loosen (rotate counter-clockwise) the cutter adjustment nut to apply more contact pressure between the reel cutter (cutting cylinder) and the bed knife (bottom blade).

- If the reel cutter (cutting cylinder) is too tight to turn:

Tighten (rotate clockwise) the cutter adjustment nut to reduce the contact pressure between the reel cutter (cutting cylinder) and the bed knife (bottom blade).

- If the blades still cannot cut well:
Perform back lapping of the reel cutter (cutting cylinder).

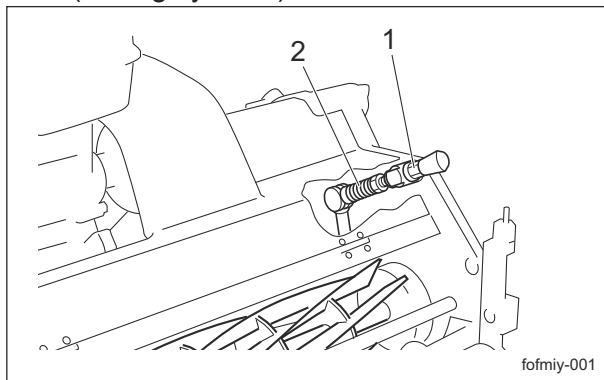

Adjustment of Blade Engagement_002

1	Cutter adjustment nut
2	Spring

Adjustment of Cutting Height

Important

This applies the set cutting height that differs from the actual cutting height.

Adjust the cutting height to fit your cutting work.

- Cutting Height and Blade Thickness of Bed Knife (Bottom Blade)

Important

The recommended minimum cutting heights are based on those of common greens. These values are affected by the conditions of the greens and the machine specifications. If the green undulation is hard, set it a little bit higher in order not to damage the green surface.

The recommended minimum cutting height according to the blade thickness of the bed knife (bottom blade) is as indicated below.

Maintenance

Type	Blade type	Thickness of blade (mm/inch)	Rough minimum cutting height (mm/inch)	Code	Part name	Remarks	
LM56GC	Standard blade	1.0/0.039	2.5/0.098	K2511000490	1 Bed knife 22		
				K2511000510	1 Bed knife 22-44.5	Offset 2.5 mm	
		1.5/0.059	3.0/0.118	K2511000270	1.5 Bed knife 55G		
				K2511000390	1.5 Bed knife 55G-47	Offset 5 mm	
		2.0/0.079	3.5/0.138	K2511000280	2 Bed knife 55G		
				K2511000350	2 Bed knife 55G-47	Offset 5 mm	
	2.5/0.098	4.0/0.157	K2511000050	2.5 Bed knife 55G			
			K2511000240	2.5 Bed knife 55G-47	Offset 5 mm		
	High-speed-steel-tipped blade	3.0/0.118	4.5/0.177	K2510000060	3 Bed knife 62.5-559		Standard equipment
				K2510000160	5 Bed knife 62.5-559		
LM66GC	Standard blade	1.5/0.059	3.0/0.118	K2511000310	1.5 Bed knife 65G		
				K2511000400	1.5 Bed knife 65G-47	Offset 5 mm	
		2.0/0.079	3.5/0.138	K2511000300	2 Bed knife 65G		
				K2511000360	2 Bed knife 65G-47	Offset 5 mm	
	2.5/0.098	4.0/0.157	K2511000200	2.5 Bed knife 65G			
			K2511000250	2.5 Bed knife 65G-47	Offset 5 mm		
	High-speed-steel-tipped blade	3.0/0.118	4.5/0.177	K2510000150	3 Bed knife 62.5-648.4		Standard equipment
				K2510000170	5 Bed knife 62.5-648.4		
LM66TC	High-speed-steel-tipped blade	3.0/0.118	4.5/0.177	K2510000150	3 Bed knife 62.5-648.4		
				K2510000170	5 Bed knife 62.5-648.4		Standard equipment

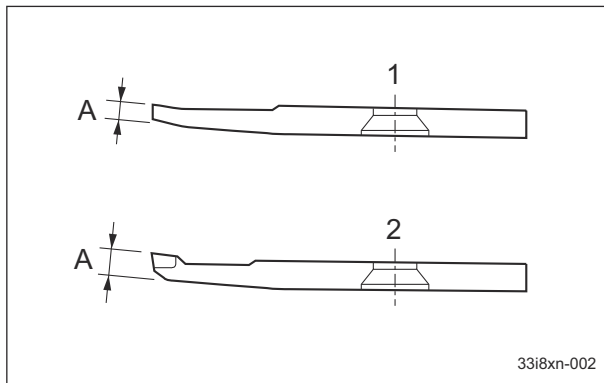

Cutting Height and Blade Thickness of Bed Knife (Bottom Blade)_001

1	Standard blade
2	High-speed-steel-tipped blade
A	Thickness of blade

■ Adjustment of Front Roller

You can adjust the cutting height by moving the front roller up or down.

The cutting height can be adjusted to the maximum of 29.0 mm (1.141 in).

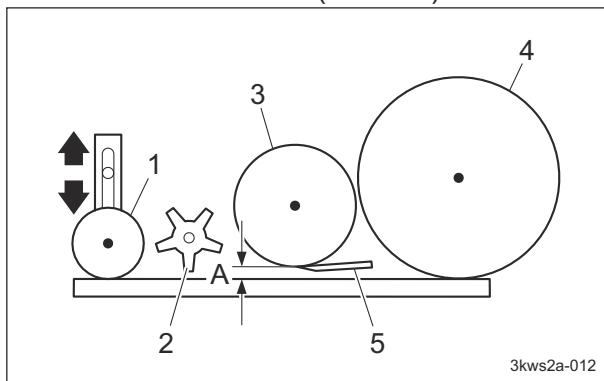

Adjustment of Front Roller_001

1	Front roller
2	Front groomer
3	Reel cutter (Cutting cylinder)
4	Drum
5	Bed knife (bottom blade)
A	Cutting height

1. Set the slide caliper to the required cutting height, adjust the position of the bottom of the head of the small screw for cutting height setup in the cutting height gauge, and then securely lock it with a fly nut.

2. Loosen the nut securing the roller adjuster.

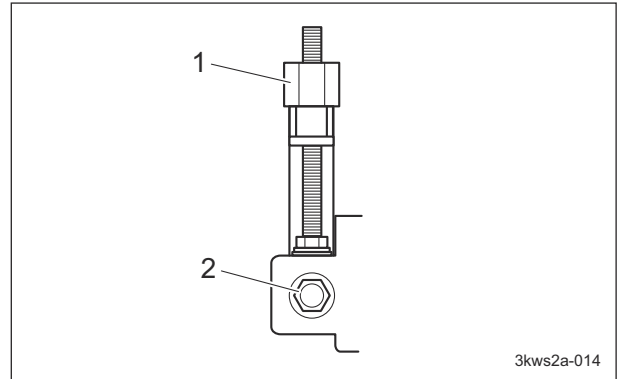

Adjustment of Front Roller_002

1	Roller adjuster
2	Nut

3. Position the cutting height gauge against the front roller and drum at the edge on the left and right sides of the mower unit.
4. Move the front roller up or down with the roller adjuster to position the front roller so that there is no gap between the bottom of the head of the small screw for cutting height setup in the cutting height gauge and the edge of the bed knife (bottom blade).

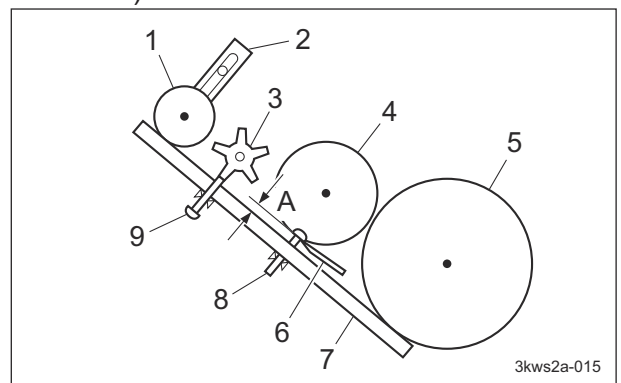

Adjustment of Front Roller_003

1	Front roller
2	Roller bracket
3	Front groomer
4	Reel cutter (Cutting cylinder)
5	Drum
6	Bed knife (bottom blade)
7	Cutting height gauge
8	Small screw for cutting height setup
9	Small screw for groomer setup
A	Cutting height

5. Follow the same steps to adjust the cutting height on the opposite side.

Maintenance

6. Tighten the nuts that secure the left and right roller brackets to secure them firmly.
7. Again, make sure that the cutting height is at the required position by positioning the cutting height gauge against the front roller and drum at the edge on the left and right sides of the mower unit.

Adjustment of Groomer

Note:

Depending on the specifications, this function may not be available.

Important

If the front groomer is being used, adjust it according to the conditions of the greens.

Important

Set the grooming height more than 0.0 mm (0.00 in) from the ground. Allowing the front groomer to go into the ground will damage the groomer shaft.

Important

If the front groomer goes in too deep, the engine and drive components may become overloaded, which will cause malfunction and damage.

Important

When using the grooming brush, adjust it to the same height as the cutting height. If the grooming brush is too low, it may quickly become damaged.

1. Set the slide caliper to the required groomer height, adjust the tip of the groomer setting screw on the cutting height gauge, and then securely lock it with a wing nut.

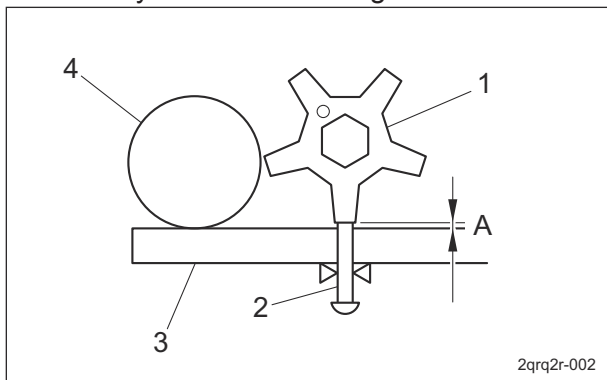

Adjustment of Groomer_001

1	Dethatching blade
2	Small screw for groomer setup
3	Cutting height gauge
4	Front roller
A	Groomer height

2. Loosen the nuts securing the left and right groomer adjustment screws.
3. Loosen left and right special nut A.

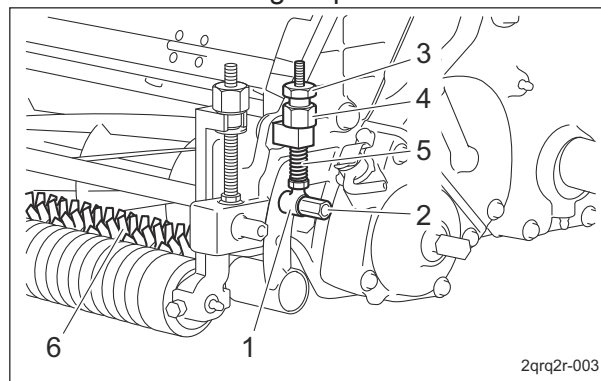

Adjustment of Groomer_002

1	Groomer adjustment screw
2	Nut
3	Special nut A
4	Special nut B
5	Spring
6	Front groomer

4. Position the cutting height gauge against the front roller and drum at the edge on the left and right sides of the mower unit.

Important

Adjust so that the small screw for groomer setup contacts the dethatching blades.

5. Adjust special nut B up or down so that the left and right sides are parallel.

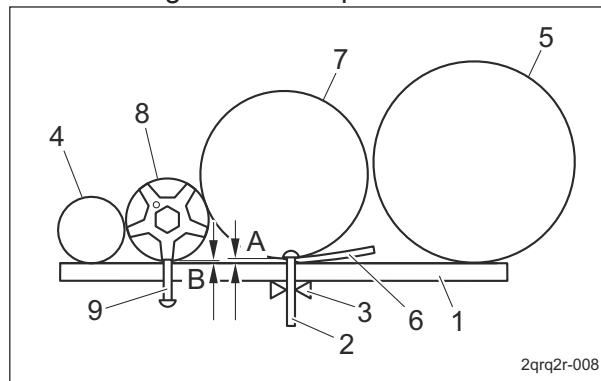

Adjustment of Groomer_003

Maintenance

1	Cutting height gauge
2	Small screw for cutting height setup
3	Fly nut
4	Front roller
5	Drum
6	Bed knife (bottom blade)
7	Reel cutter (Cutting cylinder)
8	Dethatching blade
9	Small screw for groomer setup
A	Cutting height
B	Groomer height

6. Follow the same steps to adjust the groomer height on the opposite side.
7. Firmly tighten the nuts that secure the left and right groomer adjustment screws.
8. Tighten left and right special nut A.
9. Again, make sure that the groomer height is at the required position by positioning the cutting height gauge against the front roller and drum at the edge on the left and right sides of the mower unit.



Adjustment of Groomer_004

1	Groomer adjustment screw
2	Nut
3	Special nut A
4	Special nut B
5	Spring
6	Front groomer

Note:

In the case that the front groomer is not used, you do not have to change the set groomer height.

Loosen the nuts fixing the right and left groomer adjustment screws, lift the groomer and tighten the right and left nuts to raise the front groomer so that it cannot contact the lawn.

Next time the groomer is used, loosen the right and left nuts, lower the groomer and tighten the nuts so that it can return to the groomer height set previously.

Adjustment of IGCA (Independent Grass Catcher Arm)

Note:

Depending on the specifications, this function may not be available.

Important

When adjusting the height of handle, adjust IGCA.

1. Remove the traveling tires.
 2. Flip up the stand.
 3. Install the grass catcher.
- Adjustment of the link rod:

Important

Adjust the handle pipe so that it can locate at the center of the handle guide.

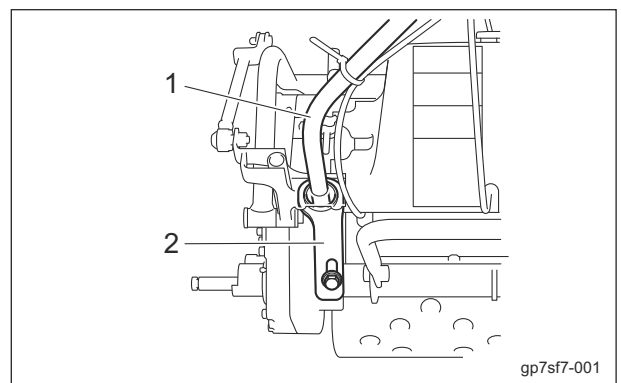

Adjustment of IGCA (Independent Grass Catcher Arm)_001

1	Handle pipe
2	Handle guide

Maintenance

Important

Adjust the right and left link rods so that they will be as long as each other.

1. Remove the snap pin and washer and then remove the flat head pin.
2. Loosen the nut A and turn the L-shape bracket to adjust the length of the link rod. When raising the handle, shorten the link rod. When lowering the handle, lengthen the link rod.
3. Attach the flat head pin, washer and snap pin to the forefront of slotted hole of the L-shape bracket.
4. Make sure that the handle pipe locates at the center of the handle guide.
5. Tighten the nut A.

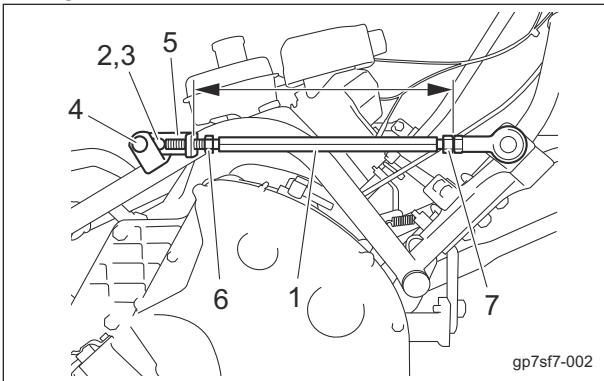

Adjustment of IGCA (Independent Grass Catcher Arm)_002

1	Link rod
2	Snap pin
3	Washer
4	Flat head pin
5	L-shape bracket
6	Nut A
7	Nut B

6. Repeat the same process for adjustment of the opposite link rod.

Adjustment of gap for the grass catcher:

Important

Adjust so that the grass catcher will not overlap with the stay.

Important

Adjust so that the small gap between the grass catcher and the stay will be even.

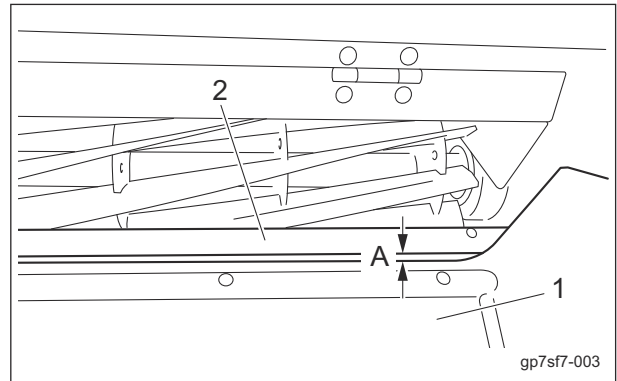

Adjustment of IGCA (Independent Grass Catcher Arm)_003

1	Grass catcher
2	Stay
A	Gap

1. Loosen the right and left locknuts.
2. Remove the right and left clip pin.

Important

The shaft has a through-hole into which the clip pin will be inserted.

To adjust length always turn the shaft 180 degrees to keep holes aligned.

3. Turn the right and left shafts to adjust so that the gap between the grass catcher and the stay will be 1.0 mm (0.039 in).
4. Tighten the right and left locknuts.

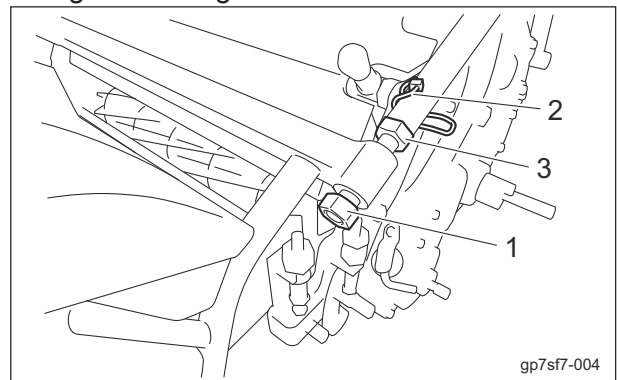

Adjustment of IGCA (Independent Grass Catcher Arm)_004

1	Locknut
2	Clip pin
3	Shaft

Adjustment of Cutter Adjustment Spring

⚠ Caution

When handling the reel cutter (cutting cylinder) or bed knife (bottom blade), wear gloves to protect your hands. Pay attention not to let the reel cutter (cutting cylinder) catch your gloves. Otherwise, you may injure your hand or fingers.

If the diameter of the reel cutter (cutting cylinder) becomes smaller, adjust the cutter adjustment spring.

1. Adjust the blade engagement.
2. Loosen the spring adjusting screw and the nut, and then adjust the length of the coil spring to approximately 50 mm (1.97 in).

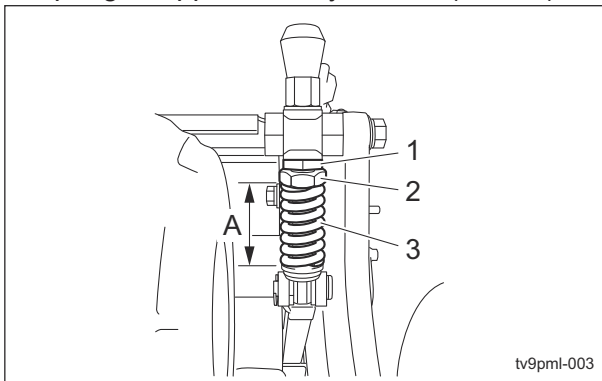

Adjustment of Cutter Adjustment Spring_001

1	Spring adjusting screw
2	Nut
3	Spring
A	50 mm (1.97 in)

Adjustment of CAM

Turn the cam bush on both sides of the bed knife (bottom blade), and the blade can be raised and lowered respectively by maximum 0.3 mm (0.012 in).

The above method is used when the edges of the reel cutter (cutting cylinder) and the bed knife (bottom blade) are not in parallel.

Check for the gap between the reel cutter (cutting cylinder) and the bed knife (bottom blade).

Loosen the locknut when adjusting the cam bush.

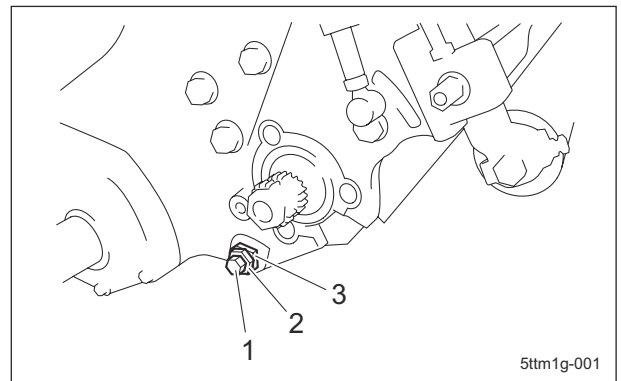

Adjustment of CAM_001

1	Cam bush
2	Locknut
3	Cutter pin

When the gap appears on the left side.:

1. Turn the left cam bush clockwise to eliminate only the gap distance. When you raise the bed knife (bottom blade) by 0.1 mm (0.004 in), turn the left cam bush clockwise 30 degrees.
2. Once the adjustment completed, tighten the locknut securely.

When the gap appears on the right side.:

1. Turn the right cam bush counterclockwise to eliminate only the gap distance.
2. Once the adjustment completed, tighten the locknut securely.

Note:

The figure below shows the situation when you see from the left side.

The right side is mirror reversed.

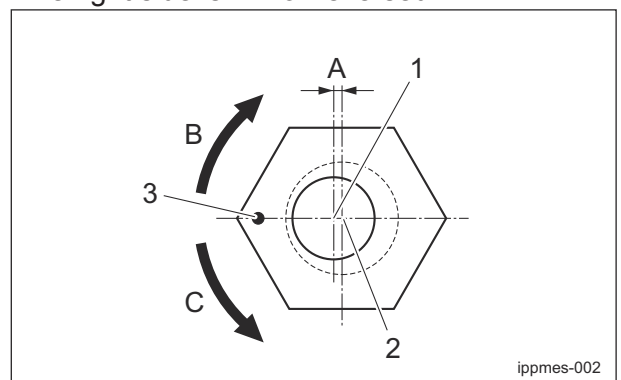

Adjustment of CAM_002

1	Center of cutter pin
2	Center of cam bush
3	Punch mark
A	0.3 mm (0.012 in)
B	Raising the bed knife
C	Lowering the bed knife.

Maintenance

Back Lapping

Back lapping is work similar to sharpening a cooking knife. If the edges of the reel cutter (cutting cylinder) and the bed knife (bottom blade) become blunt and make cutting difficult, both the reel cutter (cutting cylinder) and the bed knife (bottom blade) should be simultaneously sharpened by reversing the reel cutter (cutting cylinder) with an abrasive paste applied.

However, back lapping is a temporary measure and would not restore the sharpness completely.

If the edges of the reel cutter (cutting cylinder) and the bed knife (bottom blade) become blunt and make cutting difficult, follow the steps below to perform back lapping.

Warning

During back lapping, the reel cutter (cutting cylinder) rotates. Keep hands and feet away from moving parts.

Caution

Do not perform back lapping with any other persons.

1. Have the following items ready: Strips of Takumi Paper (Baroness genuine paper strips) or newspaper, Abrasive [Back lapping powder mixed with oil; or gel compound (Baroness genuine abrasive)], Brush.

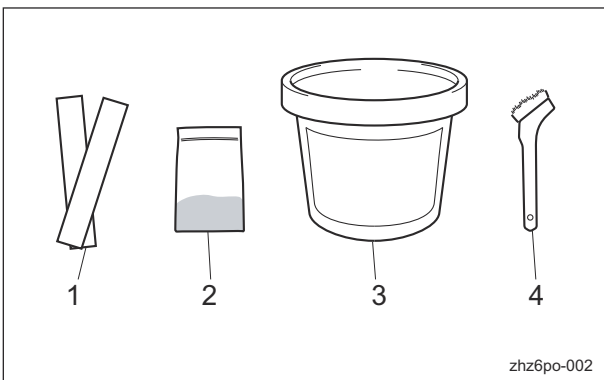

Back Lapping_001

1	Takumi Paper or newspaper
2	Back lapping powder
3	Gel compound
4	Brush

Note:

The mixing ratio for the abrasive, in volume, is one part back lapping powder (#200 - #400) to three or four parts oil.

2. Have a lapping machine or lapping handle ready.

Caution

When handling the reel cutter (cutting cylinder) or bed knife (bottom blade), wear gloves to protect your hands. However, pay attention not to let the reel cutter (cutting cylinder) catch your gloves, etc. Otherwise, you may injure your hand or fingers.

Important

Check the sharpness of the blade by checking the blade engagement after cutting grass.

3. Stop the engine.
4. Set the traveling/working selector lever to the "Travel OFF" position.

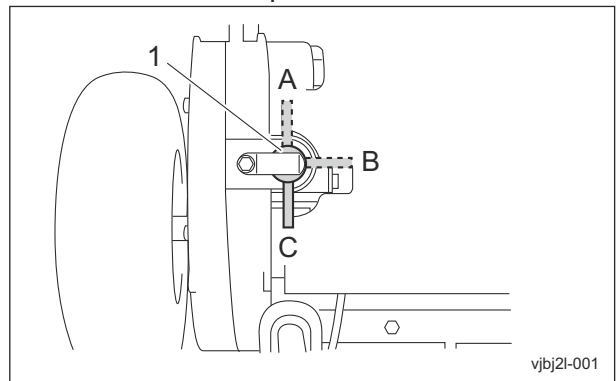

Back Lapping_002

1	Traveling/Working selector lever
A	Reel ON
B	Travel ON
C	Travel OFF

5. Insert one or two strips of Takumi Paper or newspaper into the space between the reel cutter (cutting cylinder) and the bed knife (bottom blade) at an angle of 90 degrees. Then, rotate the reel cutter (cutting cylinder) counter-clockwise (when you face the mower unit from the left) to check the sharpness of the blades.

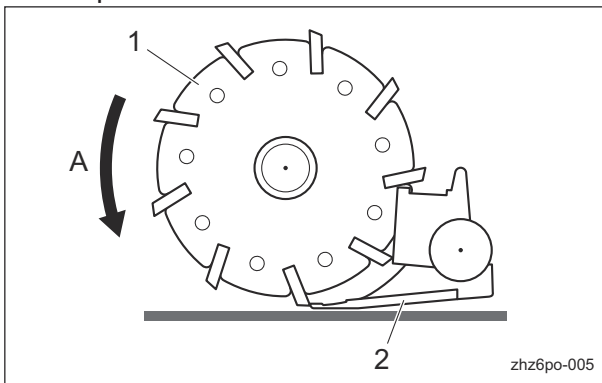

Back Lapping_003

1	Reel cutter (Cutting cylinder)
2	Bed knife (bottom blade)
A	Rotation direction

6. Check the sharpness of the entire range (three or four points) of the reel cutter (cutting cylinder).
 7. With a piece of chalk, etc., mark locations on the blade that are sharp.
 8. With a roller receiver, jack stand, etc., position the machine so that the bed knife (bottom blade) is level.

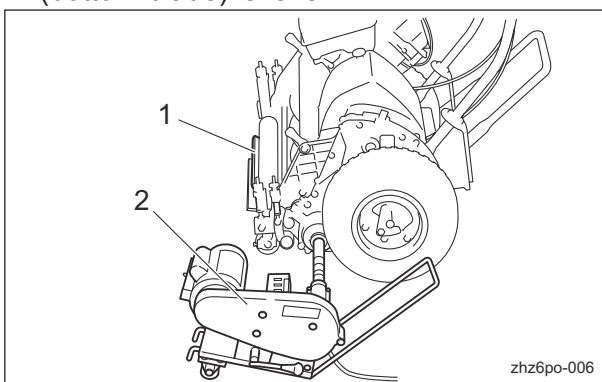

Back Lapping_004

1	Roller receiver
2	Lapping machine

9. Connect the lapping machine or lapping handle to the lapping bolt of the machine.

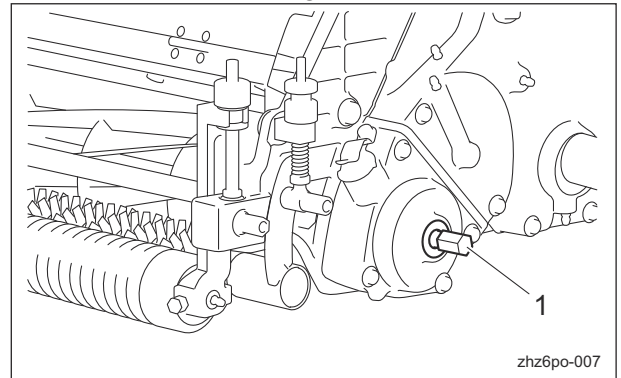

Back Lapping_005

1	Lapping bolt
---	--------------

10. Rotate the reel cutter (cutting cylinder) clockwise (reverse rotation) when you face the mower unit from the left.
 · Turn on the lapping machine or rotate the lapping handle.

Important

The right side of the reel cutter (cutting cylinder) (when you face the mower unit from the front) is inclined to wear earlier than the left side. Accordingly be sure to move the brush from the left to the right to apply the abrasive.

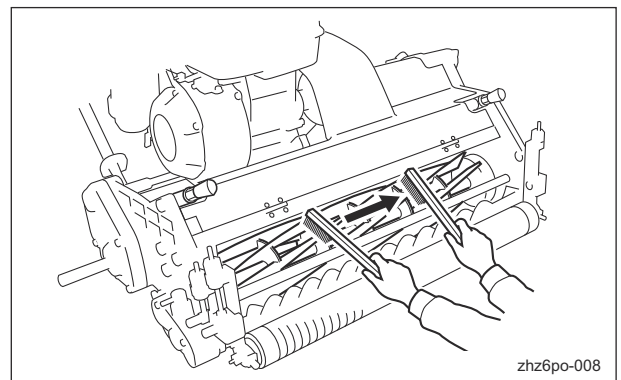

Back Lapping_006

11. Apply the abrasive evenly with the brush on the top side of reel cutter (cutting cylinder) where strips of Takumi Paper or newspaper were cut well or of chalk-marked locations. (Never apply to blunt areas.)
 12. Rotate the reel cutter (cutting cylinder) for a while and stop its rotation when the sound of contact is lost.
 · Turn off the lapping machine or stop rotating the lapping handle.

Maintenance

13. Remove the lapping machine or lapping handle.
14. Wash off or wipe off with a cloth, etc., the abrasive from the reel cutter (cutting cylinder), and then check the sharpness.
15. Repeat steps 5 to 14 until the entire range (three or four points) of the reel cutter (cutting cylinder) is uniformly sharpened.
16. Finally, apply abrasive to the entire blade width of the reel cutter (cutting cylinder) and perform final back lapping.

Important

When cleaning, do not allow water to come into contact with the engine or electrical components.

17. Wash off the abrasive with a washer, etc.
18. While checking the blade for sharpness, adjust blade engagement.

Sharpening of Reel Cutter (Cutting Cylinder)

The sharpening of the reel cutter (cutting cylinder) consists in maintaining its roundness and creating a relief (second edge face).

This work should be performed if the sharpness cannot be restored, even after back lapping, or if the relief (second edge face) has worn away.

Sharpen the reel cutter (cutting cylinder) when the sharpness cannot be restored, even after back lapping, or when the relief (second edge face) has worn away, there is full contact or back lapping takes too much time.

In addition, if the reel cutter (cutting cylinder) becomes worn and its shape conical, perform cylindrical grinding to return it to a cylindrical shape.

For sharpening the reel cutter (cutting cylinder), contact your dealer or Baroness unless you have a grinding machine.

Caution

Both the reel cutter (cutting cylinder) and the bed knife (bottom blade) are edged tools. Handle them carefully, since they could cut your hands and feet.

Caution

Wear gloves when touching edged tools to avoid cutting your hands.

The criteria for sharpening the reel cutter (cutting cylinder) are described below. However, these criteria are only references and do not guarantee performance of a reel cutter (cutting cylinder).

1. If the outer diameter of the reel cutter (cutting cylinder) after sharpening is more than the usage limit, the reel cutter (cutting cylinder) can be sharpened.

New		Usage limit	
Dimension A (Outer diameter of reel cutter (cutting cylinder))	Dimension B (Distance from blade edge to outer edge of reel cutter (cutting cylinder) shaft)	Dimension A (Outer diameter of reel cutter (cutting cylinder))	Dimension B (Distance from blade edge to outer edge of reel cutter (cutting cylinder) shaft)
128 mm (5.04 in)	51.3 mm (2.02 in)	118 mm (4.65 in)	46.3 mm (1.82 in)

Note:

The outer diameter of the reel cutter (cutting cylinder) shaft is 25.4 mm (1.00 in).

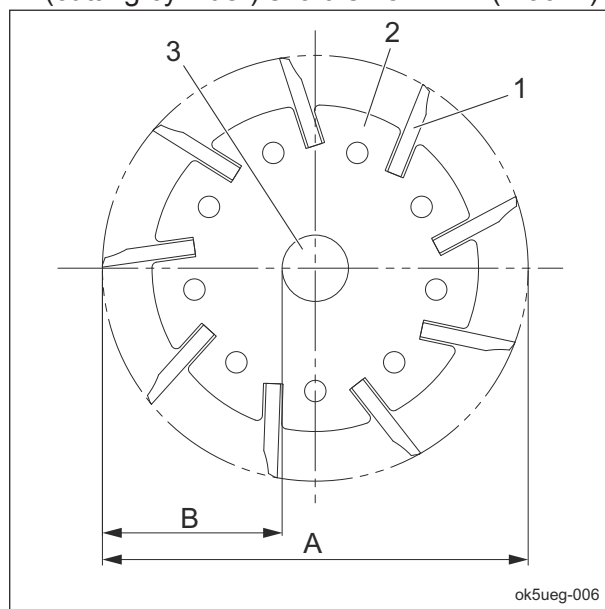

Sharpening of Reel Cutter (Cutting Cylinder)_001

1	Reel cutter (cutting cylinder) blade
2	Reel cutter (cutting cylinder) disc
3	Reel cutter (cutting cylinder) shaft
A	Outer diameter of reel cutter (cutting cylinder)
B	Distance from blade edge to outer edge of reel cutter (cutting cylinder) shaft

2. Sharpening is necessary when the reel cutter (cutting cylinder) reaches a condition described below.

[1] When the sharpening width (length of contacting surface of bed knife (bottom blade)) for the outer diameter of the reel cutter (cutting cylinder) is greater than the usage limit.

Outer diameter of reel cutter (cutting cylinder) (new part)	Usage limit of sharpening width for outer diameter of reel cutter (cutting cylinder)
128 mm (5.04 in)	2.5 mm (0.10 in) (factory-recommended)

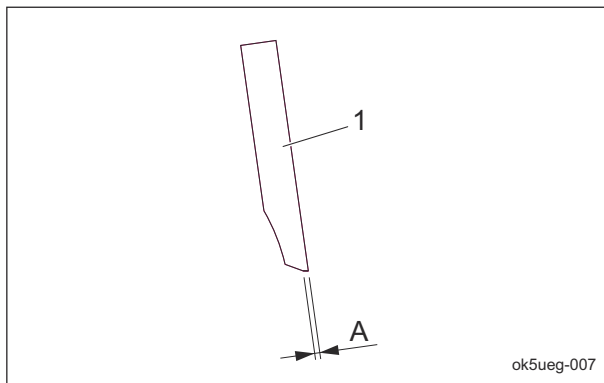

Sharpening of Reel Cutter (Cutting Cylinder)_002

1	Reel cutter (cutting cylinder) blade
A	Sharpening width for outer diameter of reel cutter (cutting cylinder)

[2] When the edges become blunt or the blade edge cannot be formed with back lapping

[3] When the reel cutter (cutting cylinder) becomes worn and its shape conical, or when blade engagement adjustment cannot be performed

Replacement

Engine

Replacement of Engine Oil



Caution
Be careful with hot oil, which could cause burns if it contacts your skin.

Important

When you replace the engine oil, be sure to drain it into a bowl and discard it in accordance with local laws and regulations.

Important

Be sure to use engine oil that is classified as API Service Grade SE or higher, with an SAE Viscosity that is appropriate for the operating environment (ambient temperature).

Important

When installing the oil level gauge, tighten it securely.

Replace the engine oil more frequently if the engine oil is contaminated, and especially if you use the machine in dusty areas or operate the engine at high loads or in high temperatures.

1. Follow the steps below to remove the old engine oil.

[1] Start and run the engine to warm up the engine oil.

[2] With the machine on a level surface, stop the engine.

[3] Remove the drain plug, and then drain the old engine oil into a container.

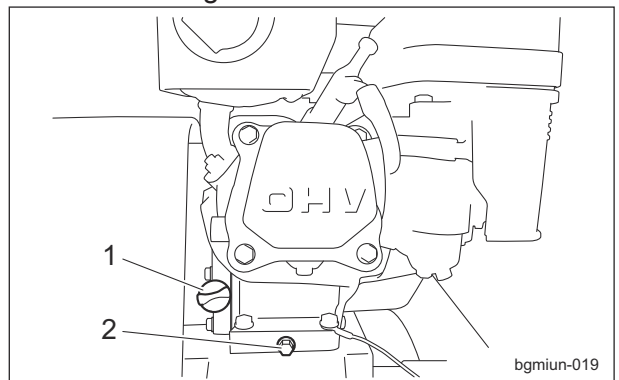

Replacement of Engine Oil_001

1	Oil level gauge (Oil filler port)
2	Drain plug

[4] Re-place the drain plug onto the engine.

2. Remove the oil level gauge.

Supply oil until it reaches a level in the upper limit line on the oil level gauge.

The engine oil quantity is approximately 0.56 dm³ (0.56 L).

3. Securely tighten the oil level gauge.

Maintenance

4. Check underneath the machine for oil leakage.

Replacement of Air Cleaner Element

Important

A contaminated air cleaner element may cause malfunction of the engine.

1. The timing for replacing the air cleaner element is described below.
 - [1] Replace the air cleaner element in accordance with the Maintenance Schedule.
 - [2] If it is significantly contaminated, replace it, even if the hours of operation do not exceed the specified time.
2. Replace the air cleaner element by following the same steps as for cleaning the air cleaner element. "Cleaning of Air Cleaner Element" (Page 6-3)

Cutting Section

Replacement of Reel Cutter (Cutting Cylinder)

Caution

Both the reel cutter (cutting cylinder) and the bed knife (bottom blade) are edged tools. Handle them carefully, since they could cut your hands and feet.

Caution

Wear gloves when touching edged tools to avoid cutting your hands.

The criteria for replacing the reel cutter (cutting cylinder) are described below. However, these criteria are only a reference and do not guarantee performance like that of a new reel cutter (cutting cylinder).

1. When the outer diameter of the reel cutter (cutting cylinder) is less than the usage limit

New		Usage limit	
Dimension A (Outer diameter of reel cutter (cutting cylinder))	Dimension B (Distance from blade edge to outer edge of reel cutter (cutting cylinder) shaft)	Dimension A (Outer diameter of reel cutter (cutting cylinder))	Dimension B (Distance from blade edge to outer edge of reel cutter (cutting cylinder) shaft)
128 mm (5.04 in)	51.3 mm (2.02 in)	118 mm (4.65 in)	46.3 mm (1.82 in)

Note:
The outer diameter of the reel cutter (cutting cylinder) shaft is 25.4 mm (1.00 in).

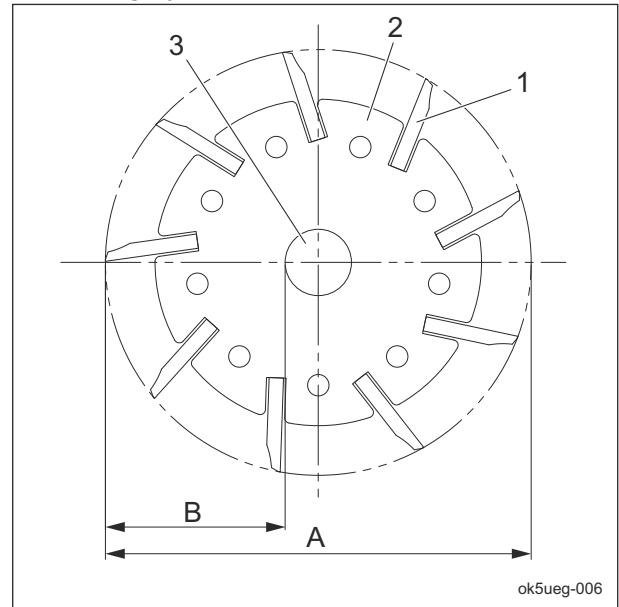

Replacement of Reel Cutter (Cutting Cylinder)_001

1	Reel cutter (cutting cylinder) blade
2	Reel cutter (cutting cylinder) disc
3	Reel cutter (cutting cylinder) shaft
A	Outer diameter of reel cutter (cutting cylinder)
B	Distance from blade edge to outer edge of reel cutter (cutting cylinder) shaft

■ Installation of The Reel Cutter (Cutting Cylinder)

⚠ Caution

Both the reel cutter (cutting cylinder) and the bed knife (bottom blade) are edged tools. Handle them carefully, since they could cut your hands and feet.

⚠ Caution

When handling the reel cutter (cutting cylinder) or bed knife (bottom blade), wear gloves to protect your hands. Pay attention not to let the reel cutter (cutting cylinder) catch your gloves. Otherwise, you may injure your hand or fingers.

Follow the steps below to replace the bearings and oil seals on the left and right ends of the reel cutter (cutting cylinder).

Important

Use 30204JRP6 as bearing.

1. Fill up the bearings and oil seals with grease (Excelite EP No. 2).
2. Install the reel cutter (cutting cylinder) onto the frame.
3. Tighten the nut until the length of the spring reaches 11.5 mm (0.453 in), and then lock it.

Note:

Preloading with a constant force by spring pressure is possible.

4. Measure the rotating torque of the reel cutter (cutting cylinder) with a torque wrench.
The specified value is 0.8 to 1.0 N·m (8 to 10 kgf·cm).

Specification without groomer:

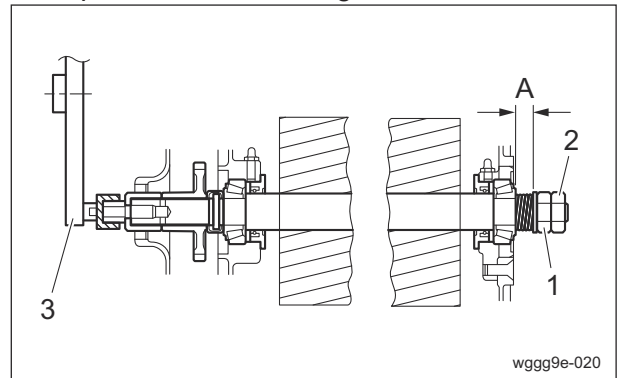

Installation of The Reel Cutter (Cutting Cylinder)_001

1	Washer
2	Left-hand nut
3	Torque wrench
A	11.5 mm (0.453 in)

Specification with groomer:

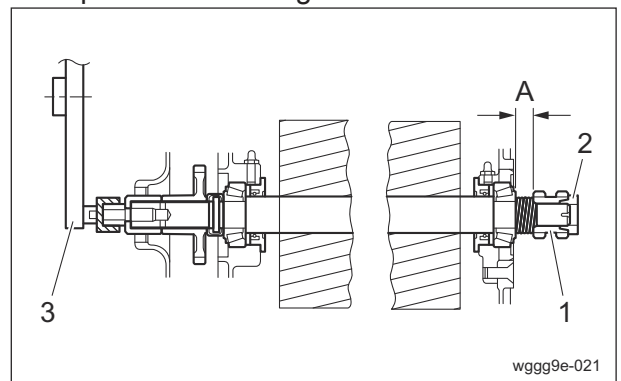

Installation of The Reel Cutter (Cutting Cylinder)_002

1	Reel gear
2	Reel gear fixing nut
3	Torque wrench
A	11.5 mm (0.453 in)

Maintenance

Procedure to Remove/Install The Small Cover (Left)

■Removal of The Small Cover (Left)

1. Insert an item such as a wooden hammer handle into the reel cutter to prevent it from turning, and remove the lapping bolt, the disk spring, and the gear retainer collar.

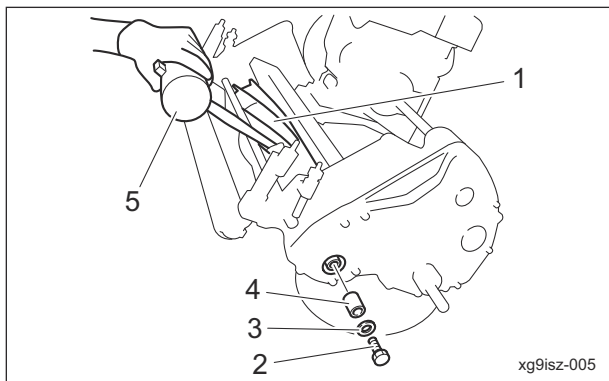

Removal of The Small Cover (Left)_001

1	Reel cutter
2	Lapping bolt
3	Disk spring
4	Gear retainer collar
5	Wooden hammer

2. Unscrew the 4 bolts, and then detach the small cover (left).

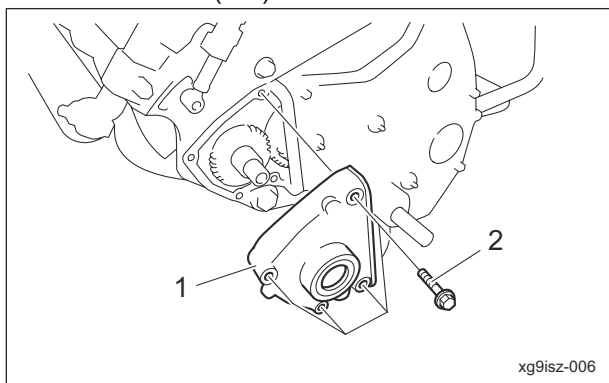

Removal of The Small Cover (Left)_002

1	Small cover (left)
2	Bolt

■Installation of The Small Cover (Left)

1. Attach the small cover (left) temporarily to the frame with four bolts.

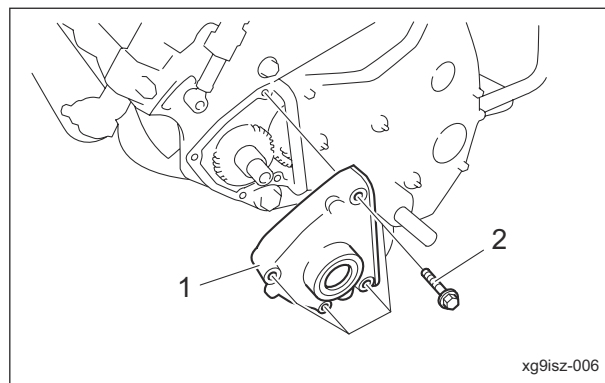

Installation of The Small Cover (Left)_001

1	The small cover (left)
2	Bolt

Important

Be sure that there is no gap between the oil seal fitted in the small cover (left) and the gear retainer collar.

2. Install the gear retainer collar to the reel cutter shaft while adjusting the position of the small cover (left).
3. Tighten the 4 bolts which have temporarily been attached to the small cover (left).
4. Insert an item such as a wooden hammer handle into the reel cutter to prevent it from turning, and install the disk spring and the lapping bolt.

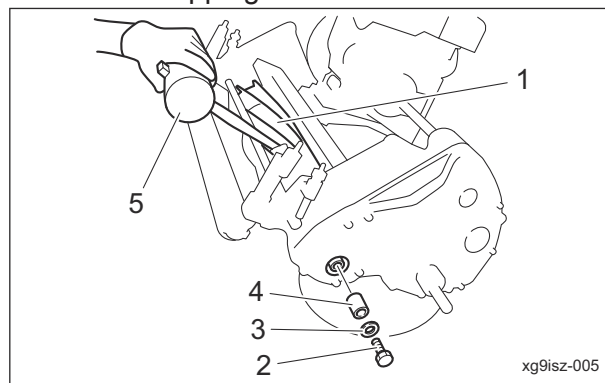

Installation of The Small Cover (Left)_002

1	Reel cutter
2	Lapping bolt
3	Disk spring
4	Gear retainer collar
5	Wooden hammer

Replacement of Bed Knife (Bottom Blade)

⚠ Caution

Both the reel cutter (cutting cylinder) and the bed knife (bottom blade) are edged tools. Handle them carefully, since they could cut your hands and feet.

⚠ Caution

Wear gloves when touching edged tools to avoid cutting your hands.

The criteria for replacing the bed knife (bottom blade) are described below.

1. When the reel cutter (cutting cylinder) is ground
2. When the reel cutter (cutting cylinder) is replaced
3. When the bed knife (bottom blade) is worn

Standard blade
Replace the bed knife (bottom blade) before it no longer has a front face.

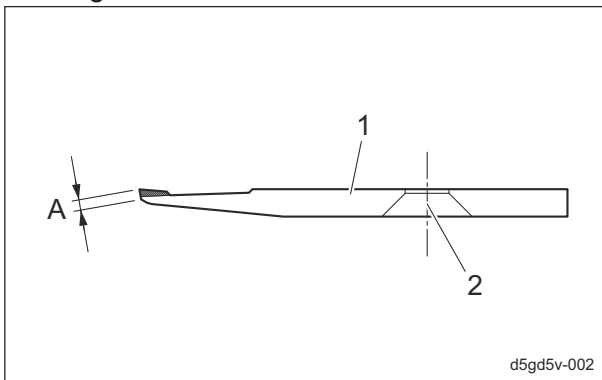

Replacement of Bed Knife (Bottom Blade)_001

1	Bed knife (bottom blade)
2	Mounting hole
A	Front face

High-speed-steel-tipped blade

Replace the bed knife (bottom blade) before it no longer has a tip.

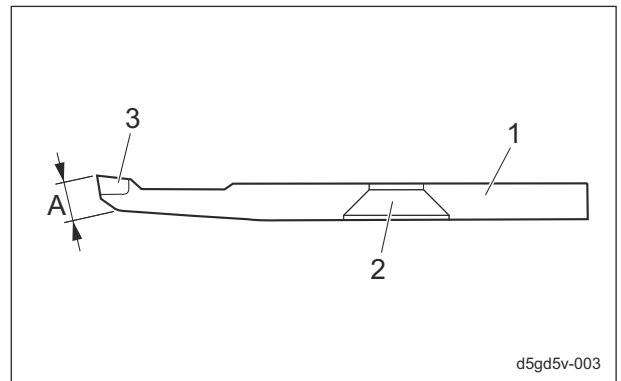

Replacement of Bed Knife (Bottom Blade)_002

1	Bed knife (bottom blade)
2	Mounting hole
3	Tip
A	Front face

Maintenance

Procedure to Remove/Install The Bed Knife Base

■Removal of The Bed Knife Base

⚠ Caution

Both the reel cutter (cutting cylinder) and the bed knife (bottom blade) are edged tools. Handle them carefully, since they could cut your hands and feet.

⚠ Caution

Wear gloves when touching edged tools to avoid cutting your hands.

⚠ Caution

Raising the front part of the machine for servicing operation may create a falling hazard. Support the machine securely.

1. Loosen the lock nuts on both sides, and then loosen the cutter pins.

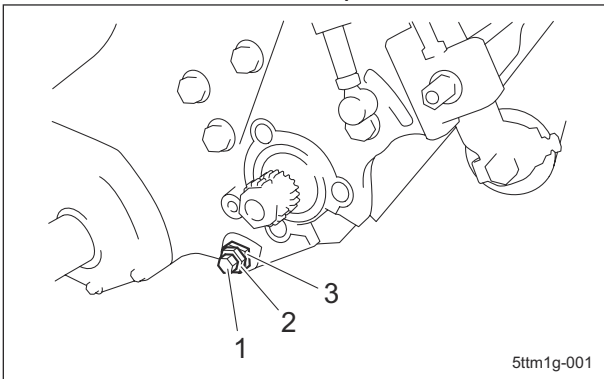

Removal of The Bed Knife Base_001

1	Cutter pin
2	Lock nut
3	Cam bush

2. Remove the 2 bolts that secure the bed knife base arm Assy and bed knife base COMP.

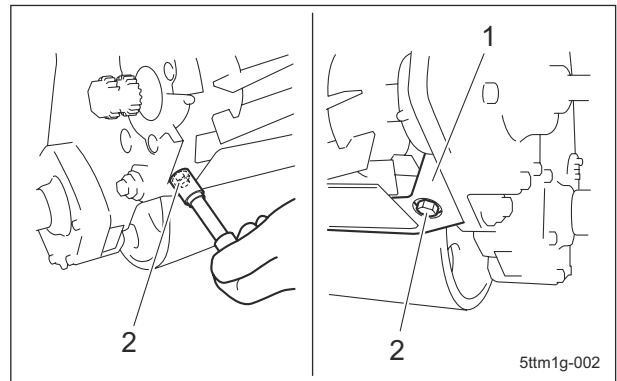

Removal of The Bed Knife Base_002

1	Bed knife base COMP
2	Bolt

Important

Keep 1 to 5 pieces of washer for clearance adjustment between the fulcrum seat and the frame if there are any of them.

3. Unscrew the fulcrum seat bolt, S washer, washer, and remove the bed knife base arm Assy from the bed knife base COMP.

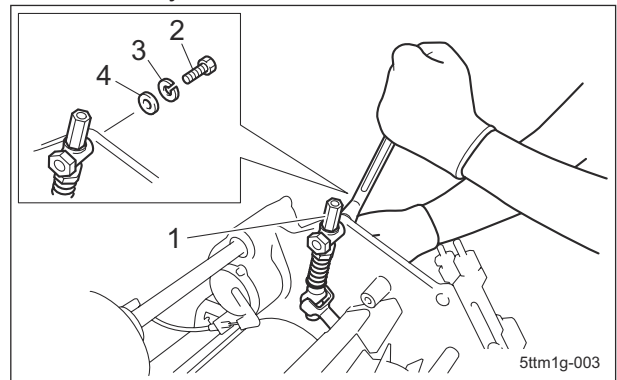

Removal of The Bed Knife Base_003

1	Bed knife base arm Assy
2	Bolt
3	S washer
4	Washer

⚠ Caution

Be careful when you remove the cutter pin as the bed knife base COMP may fall off.

4. While supporting the bed knife base COMP, remove the cutter pins and lock nuts on both sides.

5. Remove the bed knife base COMP.

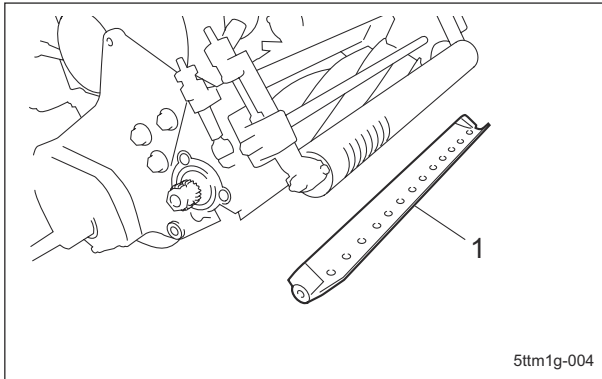

Removal of The Bed Knife Base_004

1	Bed knife base COMP
---	---------------------

■ Installation of The Bed Knife Base

Caution

Both the reel cutter (cutting cylinder) and the bed knife (bottom blade) are edged tools. Handle them carefully, since they could cut your hands and feet.

Caution

When handling the reel cutter (cutting cylinder) or bed knife (bottom blade), wear gloves to protect your hands. Pay attention not to let the reel cutter (cutting cylinder) catch your gloves. Otherwise, you may injure your hand or fingers.

Caution

While operations are performed with the front of the machine raised, it may fall. Securely support the machine.

Important

Make sure that there is no binding at the cam bushes in the frame of the mower unit.

1. Remove the right and left cam bushes.
2. Clean the cam bushes and the cam bush mounting portions on the frame and grease them.
3. Install the cam bushes.

4. Temporarily install the bed knife base COMP onto the machine with the left and right cutter pins and lock nuts.

Note:

At this time, tighten the lock nuts to the heads of the cutter pins, but do not allow the lock nuts to contact the cam bushes.

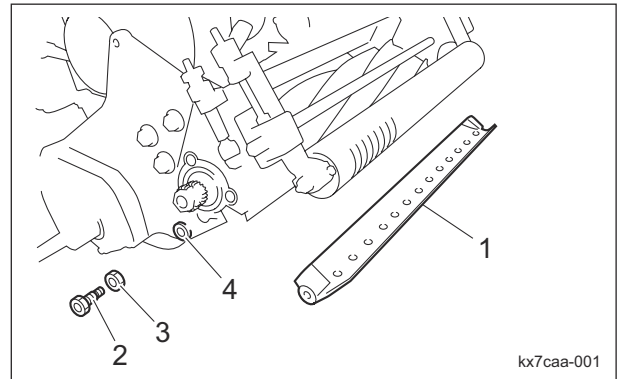

Installation of The Bed Knife Base_001

1	Bed knife base COMP
2	Cutter pin
3	Lock nut
4	Cam bush

Important

Install the bed knife base arm Assy parallel to the frame. During installation, be careful not to twist both arms.

5. Insert the bed knife base arm Assy into the bed knife base COMP.
6. Temporarily install the bed knife base arm with the bolt of the fulcrum seat.

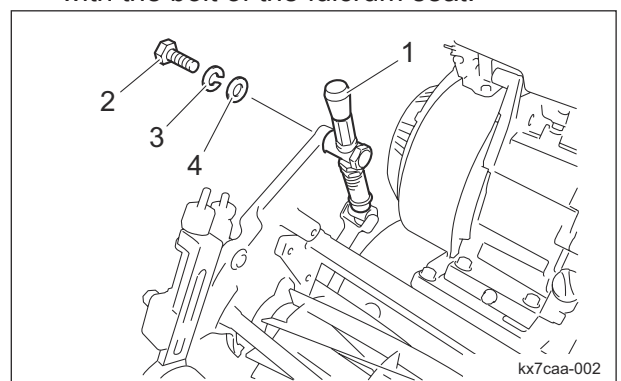

Installation of The Bed Knife Base_002

1	Bed knife base arm Assy
2	Bolt
3	Spring washer
4	Washer

Maintenance

7. Tighten the bolt used to install the bed knife base arm Assy, and then firmly secure it.

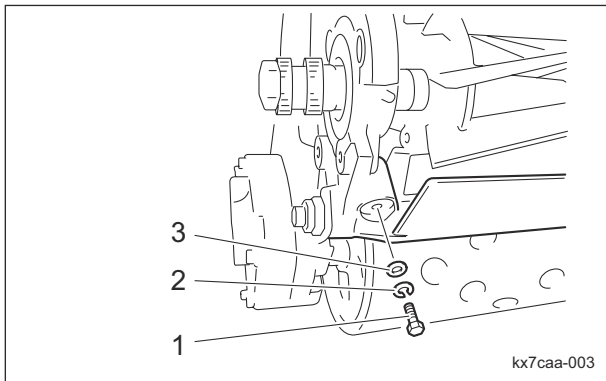

Installation of The Bed Knife Base_003

1	Bolt
2	Spring washer
3	Washer

Important

Do not tighten the left and right lock nuts.

8. Tighten the left and right cutter pins used to temporarily install the bed knife base COMP.
9. Remove the fulcrum seat bolt used to temporarily install the bed knife base arm.
 Note:
 With the weight of the bed knife base arm, the bed knife (bottom blade) will slightly come into contact with the reel cutter (cutting cylinder).
10. Align the punch mark on each (left and right) cam bush with the travel direction.

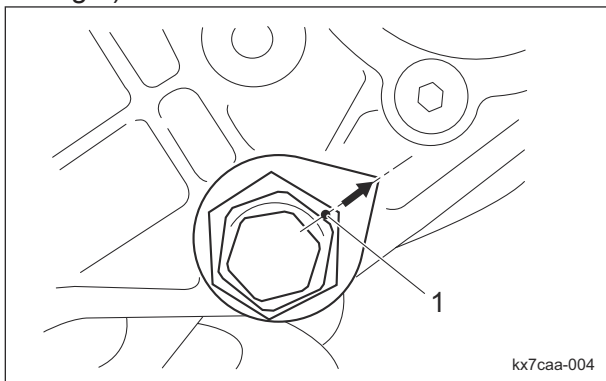

Installation of The Bed Knife Base_004

1	Punch mark
---	------------

11. Make sure that the bed knife (bottom blade) contacts the reel cutter (cutting cylinder).

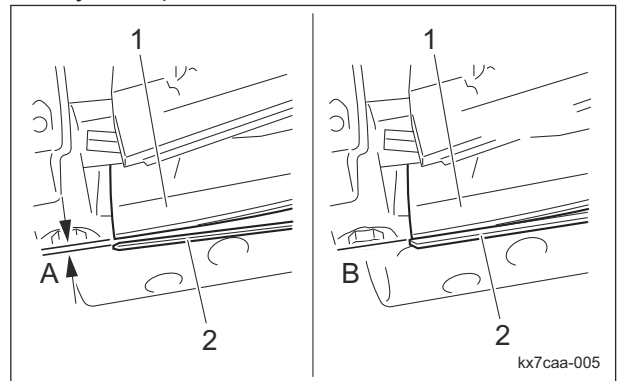

Installation of The Bed Knife Base_005

1	Reel cutter (Cutting cylinder)
2	Bed knife (bottom blade)
A	Gap
B	No gap

12. Insert one or two strips of Takumi Paper (Baroness genuine paper strips) or newspaper into the space between the reel cutter (cutting cylinder) and the bed knife (bottom blade) at an angle of 90 degrees. Then, rotate the reel cutter (cutting cylinder) counterclockwise (as seen from the left side of the mower unit) by hand to check the sharpness of the entire range (three or four points) of the reel cutter (cutting cylinder).

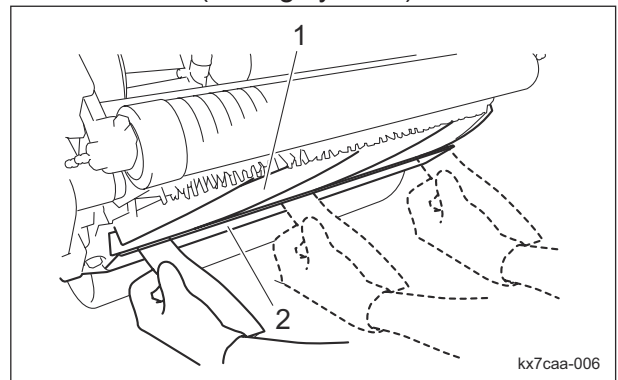

Installation of The Bed Knife Base_006

1	Reel cutter (Cutting cylinder)
2	Bed knife (bottom blade)

Maintenance

13. Adjust the positions of the cam bushes so that both sides cut.

"Adjustment of CAM" (Page 6-15)

Note:

After making adjustments, use a marker, etc., to place a mark on the frame at the position of the punch mark.

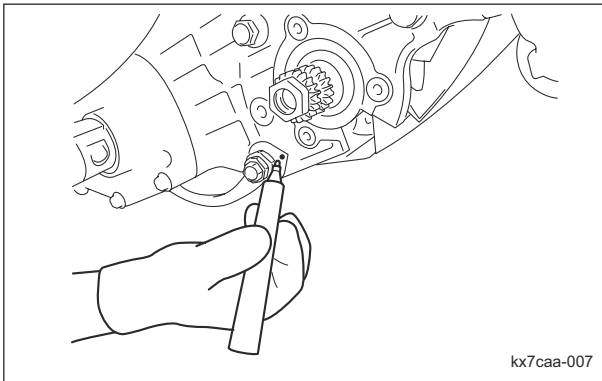

Installation of The Bed Knife Base_007

Important

If one to five gap adjustment washers had been inserted between the fulcrum seat and the frame, insert gap adjustment washers so that the gap is eliminated.

14. Install the fulcrum seats onto the left and right frames with the bolts, spring washers and washers.

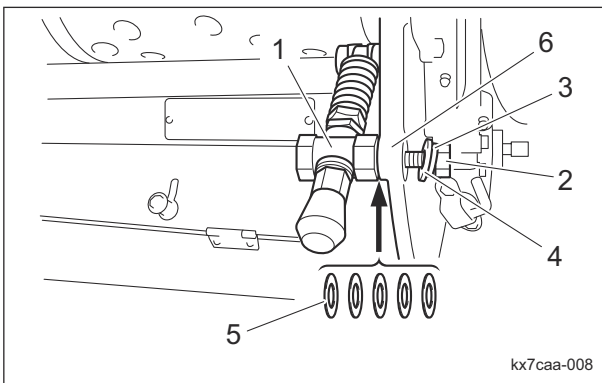

Installation of The Bed Knife Base_008

1	Fulcrum seat
2	Bolt
3	Spring washer
4	Washer
5	Gap adjustment washer
6	Frame

15. Align the vertical hole in the fulcrum seat, and then secure it.

Good alignment: The cutter adjustment bolt is centered in the hole of the fulcrum seat.

Bad alignment: The cutter adjustment bolt is not centered in the hole of the fulcrum seat.

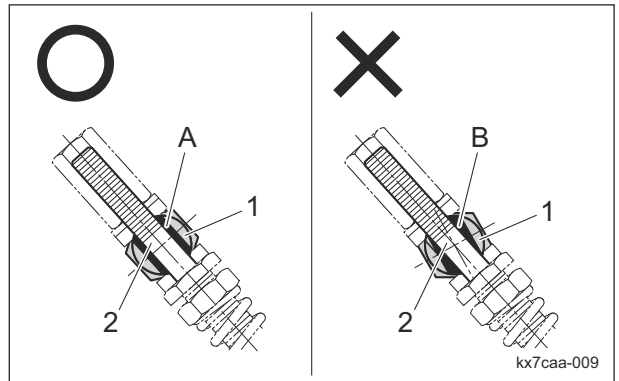

Installation of The Bed Knife Base_009

1	Fulcrum seat
2	Cutter adjustment bolt
A	Good alignment
B	Bad alignment

Important

Make sure that the cam bush does not move from the marked position.

16. Tighten the lock nuts of the left and right cutter pins.

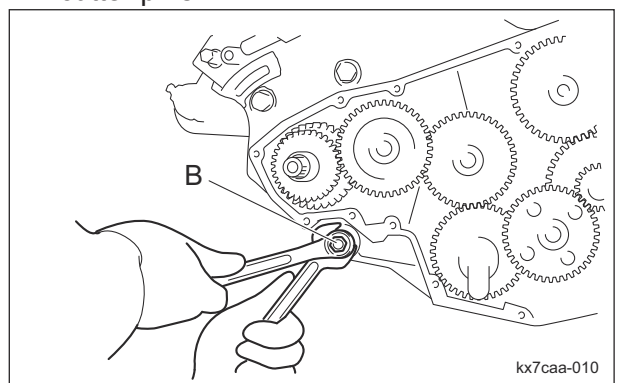

Installation of The Bed Knife Base_010

1	Lock nut
---	----------

Maintenance

Maintenance

Procedure to Remove/Install The Bed Knife

■ Removal of The Bed Knife

⚠ Caution

Both the reel cutter (cutting cylinder) and the bed knife (bottom blade) are edged tools. Handle them carefully, since they could cut your hands and feet.

⚠ Caution

Wear gloves when touching edged tools to avoid cutting your hands.

⚠ Caution

While operations are performed with the front of the machine raised, it may fall. Securely support the machine.

1. Remove the bed knife base COMP.
2. Place the bed knife base COMP on a stable workbench.
3. Remove the bed knife by loosening the screw with a hammer driver or punch.

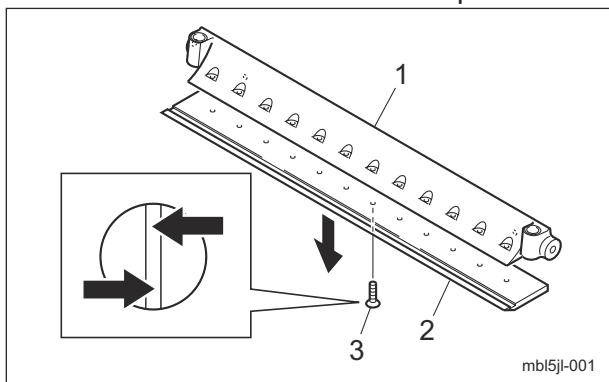

Removal of The Bed Knife_001

1	Bed knife base
2	Bed knife
3	Screw

■ Installation of The Bed Knife

⚠ Caution

Both the reel cutter (cutting cylinder) and the bed knife (bottom blade) are edged tools. Handle them carefully, since they could cut your hands and feet.

⚠ Caution

Wear gloves when touching edged tools to avoid cutting your hands.

⚠ Caution

While operations are performed with the front of the machine raised, it may fall. Securely support the machine.

Important

Be sure not to scratch the bed knife base surface where the bed knife shall be mounted. Remove rust and dust.

Important

Replace the old screws with new ones.

1. Tighten the screws uniformly with a hammer driver.

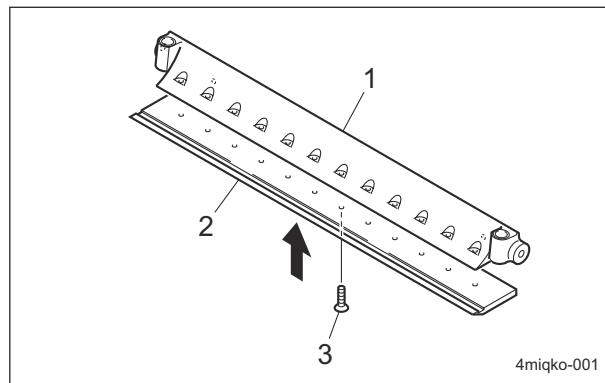

Installation of The Bed Knife_001

1	Bed knife base
2	Bed knife
3	Screw

Note:

When installing the bed knife, first tighten the center screw, and then tighten from center outwards, alternating between left and right sides.

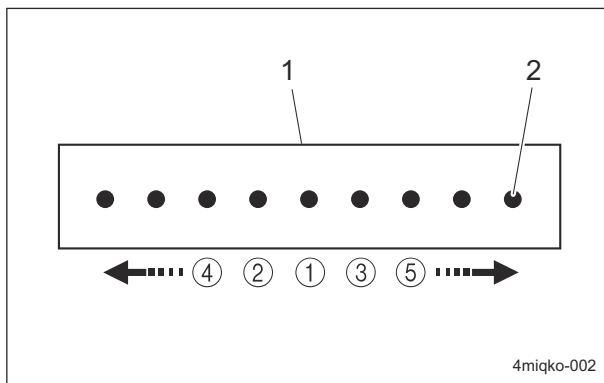

Installation of The Bed Knife_002

1	Bed knife
2	Screw

Storage

Long-Term Storage

Follow the instructions below for long-term storage of the machine.

1. Cleaning

- Remove dirt, grass clippings, oil stains etc. completely from the main vehicle and engine.

2. Replacing oil

- Inspect and replace the engine oil and element.

3. Oil filling

- Grease and lubricate the appropriate points.

4. Fuel

- Remove the fuel from the fuel tank.

5. Tire pneumatic pressure

- Set the tire air pressure slightly higher than normal, and then place the machine on a board to avoid humidity.

6. Storage location

- Cover the machine and store it in a dry place where it will not be exposed to rain.

Maintenance

Precautions for Repair Page 7-2

Adjustment Page 7-2

Adjustment of Brake Page 7-2

Adjustment of Engine Clutch Section Page 7-2



Repair

Precautions for Repair

Warning

The chapter "Repair" in this manual describes practical measures which should be performed by a mechanic with expertise. The owner should instruct the mechanic with expertise to perform repair service for this machine.

Caution

First, learn well the operations you plan to perform.

Important

Use tools appropriate for each operation.

Important

Use Baroness genuine parts for replacement and accessories.
Our product warranty may be void if you use non-genuine parts for replacement or accessories.

Adjustment

Adjustment of Brake

Caution

If the brake wire is cut, the machine will be unable to stop.
If the brake wire is cracked or damaged, replace it with a new one immediately.

Caution

If the brake is not sufficiently effective when it has been applied, adjust the brake wire.

1. Adjust the brake by use of the brake wire adjusting nut.

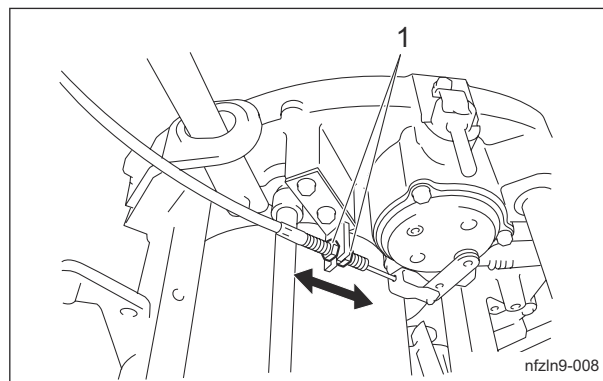

Adjustment of Brake_001

1	Adjusting nut
---	---------------

2. Make sure that the brake shoe does not touch the brake drum.
Avoid the brake always being engaged.
Note:
The brake shoe may touch the brake drum if you hear a rubbing sound or the drum feels heavy when rotating the drum.
3. Make sure that the brake lever is locked when gripping the lock lever while gripping the brake lever.

Adjustment of Engine Clutch Section

For centering adjustment of the engine clutch :
Centering adjustment of the engine clutch is required after replacement of the engine or clutch parts.

1. Adjust the engine clutch.
2. Adjust the clutch wire.
3. Adjust the clutch spring.

For clearance adjustment of the engine clutch :
Clearance adjustment of the engine clutch is required after replacement of the clutch wire or when the clutch slips.

1. Adjust the clutch wire.
2. Adjust the clutch spring.

Adjustment of Engine Clutch

Adjust the clearance between the engine clutch and clutch facing so that it will be 0.5 - 1.0 mm (0.020 - 0.039 in) when the main clutch lever set to the "ON" position.

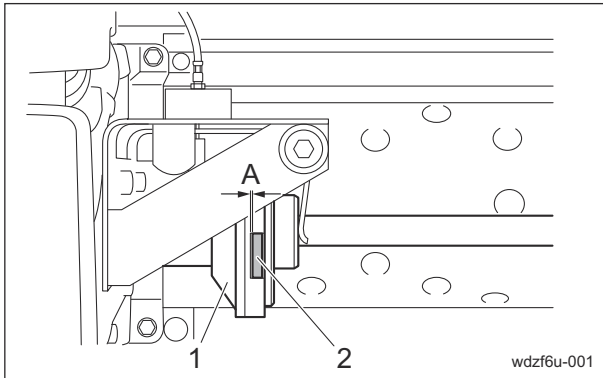

Adjustment of Engine Clutch_001

1	Engine clutch
2	Clutch facing
A	0.5 - 1.0 mm (0.020 - 0.039 in)

1. Loosen the four bolts A securing the engine.
Be sure not to loosen the bolts B.
2. Insert a thickness gauge (accessory tool) between the engine clutch and the clutch facing.
Make adjustment of the engine position so that the front and rear clearances will be the same distance, and then tighten the bolts A.

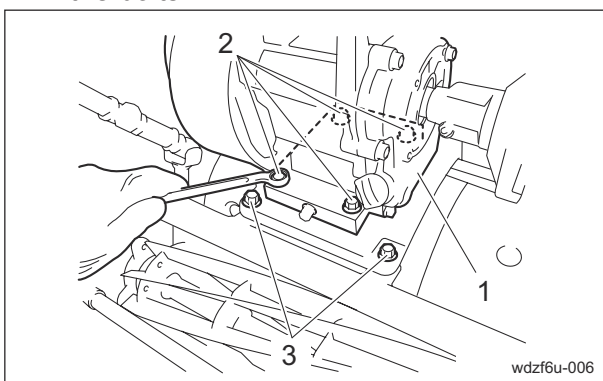

Adjustment of Engine Clutch_002

1	Engine
2	Bolt A
3	Bolt B

Adjustment of Clutch Wire

Important

Make sure that the wire is not cracked or damaged.
If the wire is cracked or damaged, replace it with a new one immediately.

Important

Due to frequent use, movement of the lever will become dull, play of the inner wire will change and the inner wire will be stretched depending on R angle of the outer wire.
Inspect them and, if necessary, implement adjustment.

Make adjustment of the clutch wire so that the operation distance of the clutch plate between "ON" and "OFF" positions of the main clutch lever will be 1 - 2 mm (0.039 - 0.079 in).

1. Loosen the clutch wire adjusting nuts.
2. Adjust the operation distance of the clutch plate by changing the clutch wire position.
3. After appropriate adjustment of the operation distance of the clutch plate completed, tighten the clutch wire adjusting nuts.

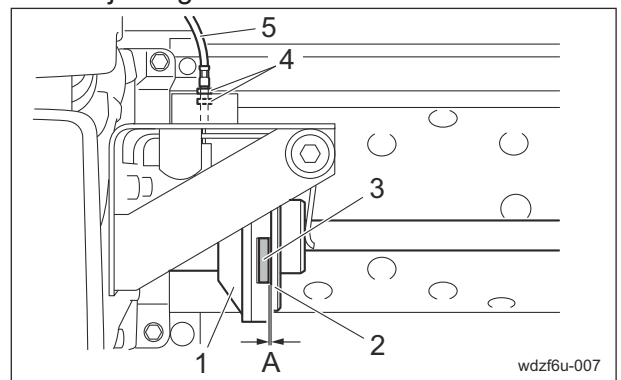

Adjustment of Clutch Wire_001

1	Engine clutch
2	Clutch plate
3	Clutch facing
4	Clutch wire adjusting nut
5	Clutch wire
A	1 - 2 mm (0.039 - 0.079 in)

Repair

Adjustment of Clutch Spring

The factory default setting of the clutch spring total length is approximately 63 mm (2.48 in).

The longer the spring is set, the lighter clutch handling is provided. The shorter, the heavier.

1. Make adjustment with the spring adjustment nut so that the total length of the clutch spring will be approximately 63 mm (2.48 in) when the main clutch lever set to the "ON" position.
2. Loosen the lock nut and adjust the clutch spring total length with the spring adjustment nut.
3. Confirm that there is no engine clutch slipping when the main clutch lever set to the "ON" position.
4. Tighten the lock nut.

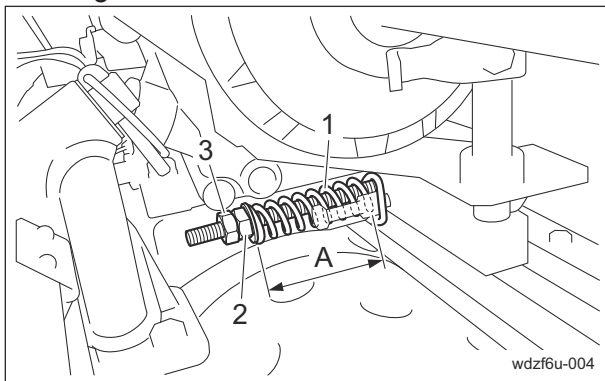

Adjustment of Clutch Spring_001

1	Clutch spring
2	Spring adjustment nut
3	Lock nut
A	63 mm (2.48 in)

Appended Table

Tightening TorquesPage 8-2

- Standard Tightening TorquesPage 8-2
- Principal Tightening Torques Page 8-4

Daily Check List Page 8-5

Maintenance Schedule Page 8-6

List of Adjusted Values Page 8-8

**Troubleshooting Procedures of
Aftercut Appearance Page 8-9**

- ScalpingPage 8-9
- Angled Mismatch Page 8-9
- Overlap Marks Page 8-10
- Blade Does Not Cut Page 8-11
- Uneven Blade EngagementPage 8-12

Appended Table

Tightening Torques

Important

Refer to the Tightening Torque table.
Note that the Baroness product warranty may not apply to defects caused by incorrect or overtorque tightening, etc.

Standard Tightening Torques

Bolts and Nuts



Important

A number of bolts are used in each part of this machine.
Be sure to re-tighten the bolts and nuts, because they may be loosened at the earlier stage of the use.

- As to the bolts and nuts without any special instruction, tighten them in appropriate tightening torque with proper tool.
Too much tightening may cause the looseness or damage of the screw.
- The strength of tightening is determined by types of screws, strength, the friction of thread face or base face and others.
The table below is for the galvanized or parkerized bolts.
In case that the strength of internal thread is weak, it is not applied.
- Do not use rusty or sand attached "screw."
Otherwise, it may cause insufficient tightening even if you apply the specified tightening torque.
The friction of the screw face becomes higher and the tightening torque is canceled out by the friction, therefore sufficient tightening cannot be applied.
- If "screw" is wet by water or oil, do not tighten it with normal tightening torque.
If the screw is wet, the torque coefficient will get smaller and it may result in too much tightening.
Too much tightening may cause looseness by the screw stretched or result in damage.
- Do not use a bolt experienced too much burden.
- Using the impact wrench requires the skill.
Do exercise as much as possible for steady tightening.

Appended Table

Nominal diameter	General bolt		
	Strength classification 4.8		
	 tib3yb-001		
	N-m	kgf-cm	lb-in
M5	3 - 5	30.59 - 50.99	26.55 - 44.26
M6	7 - 9	71.38 - 91.77	61.96 - 79.66
M8	14 - 19	142.76 - 193.74	123.91 - 168.17
M10	29 - 38	295.71 - 387.49	256.68 - 336.34
M12	52 - 67	530.24 - 683.20	460.25 - 593.02
M14	70 - 94	713.79 - 958.52	619.57 - 831.99
M16	88 - 112	897.34 - 1142.06	778.89 - 991.31
M18	116 - 144	1,182.85 - 1,468.37	1,026.72 - 1,274.54
M20	147 - 183	1,498.96 - 1,866.05	1,301.10 - 1,619.73
M22	295	3,008.12	2,611.05
M24	370	3,772.89	3,274.87
M27	550	5,608.35	4,868.05
M30	740	7,545.78	6,549.74

Nominal diameter	Heat-treated bolt					
	Strength classification 8.8			Strength classification 10.9		
	 tib3yb-002			 tib3yb-003		
	N-m	kgf-cm	lb-in	N-m	kgf-cm	lb-in
M5	5 - 7	50.99 - 71.38	44.26 - 61.96	7 - 10	71.38 - 101.97	61.96 - 88.51
M6	8 - 11	81.58 - 112.17	70.81 - 97.36	14 - 18	142.76 - 183.55	123.91 - 159.32
M8	23 - 29	234.53 - 295.71	203.57 - 256.68	28 - 38	285.52 - 387.49	247.83 - 336.34
M10	45 - 57	458.87 - 581.23	398.30 - 504.51	58 - 76	591.43 - 774.97	513.36 - 672.68
M12	67 - 85	683.20 - 866.75	593.02 - 752.34	104 - 134	1,060.49 - 1,366.40	920.50 - 1186.03
M14	106 - 134	1,080.88 - 1,366.40	938.21 - 1,186.03	140 - 188	1,427.58 - 1,917.04	1,239.14 - 1,663.99
M16	152 - 188	1,549.94 - 1,917.04	1,345.35 - 1,663.99	210 - 260	2,141.37 - 2,651.22	1,858.71 - 2,301.26
M18	200 - 240	2,039.40 - 2,447.28	1,770.20 - 2,124.24	280 - 340	2,855.16 - 3,466.98	2,478.28 - 3,009.34
M20	245 - 295	2,498.27 - 3,008.12	2,168.50 - 2,611.05	370 - 450	3,772.89 - 4,588.65	3,274.87 - 3,982.95
M22	-	-	-	530	5,404.41	4,691.03
M24	-	-	-	670	6,831.99	5,930.17
M27	-	-	-	1,000	10,197.00	8,851.00
M30	-	-	-	1,340	13,663.98	11,860.34

Note:
The same values are applied to "fine screw thread."

Appended Table

Principal Tightening Torques

Tightening Torque by Model

LM18GC/LM56GC/LM66GC/LM66TC

Tighten the following bolts and nuts at the torque specified in the table.

For thread locking adhesive, apply a middle strength thread locker (ThreeBond 1322 or equivalent anaerobic sealant).

Location	Code	Part name	Tightening torque			Thread locking adhesive
			N-m	kgf-cm	lb-in	
Bedknife	K0071000222	SCREW, HT FLAT HEAD M6-12	7 - 9	71.38 - 91.77	61.96 - 79.66	-
Reel shaft	K0185160002	NUT, LEFT-HANDED P1.5 M16-3	36	367.09	318.64	-
Reel shaft (Groomer model)	LM56G--1204Z0	GEAR, 20-TEETH	36	367.09	318.64	-
Front roller	K6083000042	PIN, STEPPED M15-19	29 - 38	295.71 - 387.49	256.68 - 336.34	-
Drum wheel	K001A080251	BOLT, WITH HEX. HOLE M8-25	To keep the fitting from coming off			-
Handle	K0010100252	BOLT, HT M10-25	29 - 38	295.71 - 387.49	256.68 - 336.34	-
Groomer	K0160000602	NUT, SPECIAL P1 M17 WITH M4	5 - 10	50.99 - 101.97	44.26 - 88.51	-
	K6083000143	PIN, STEPPED FOR FIXING (R) CASE	6	61.18	53.11	-

Appended Table

Daily Check List

LM18GC/LM56GC/LM66GC/LM66TC

● · · · Inspect, adjust, supply, clean (first time)

○ · · · Inspect, adjust, supply, clean

▲ · · · Replace (first time)

△ · · · Replace

Maintenance Item		Before Work	After Work	Remarks
Engine (Honda)	*1	Check engine oil	○	
	*1	Check fuel	○	
		Check fuel strainer	○	
		Check oil or water leaks	○	
	*1	Check air cleaner	○	
		Check bolts and nuts	○	
		Check engine area	○	
	Clean engine area		○	
Driving section		Check tire	○	
		Check machine exterior	○	
		Check bolts and nuts	○	
		Check main clutch lever	○	
		Check clutch lock lever	○	
		Check cover	○	
		Check brake	○	
		Check wire	○	
		Check light	○	
		Clean machine exterior		○
Cutting section		Check reel cutter and bed knife	○	
		Check cover	○	
		Check roller	○	
		Check drum	○	
		Check groomer	○	
		Check grass catcher	○	
		Check cutting section	○	
		Check bolts and nuts	○	
		Clean cutting section		○

· *1: Refer to the Engine's Owner's Manual.

Appended Table

Maintenance Schedule

LM18GC/LM56GC/LM66GC/LM66TC

Follow the maintenance schedule below.

- . . . Inspect, adjust, supply, clean (first time)
- . . . Inspect, adjust, supply, clean
- ▲ . . . Replace (first time)
- △ . . . Replace

Maintenance Item		Before Work	After Work	Every 10 hrs.	Every 25 hrs.	Every 50 hrs.	Every 100 hrs.	Every 300 hrs.	Every 500 hrs.	Every year	Every 2 years	When Required	Remarks
Engine	*2	Check spark plug					○						
	*2	Clean air cleaner element					○						Air cleaner should be cleaned more often in dusty conditions than in normal conditions
	*2	Clean spark arrester					○						
	*2	Clean sediment cup					○						
	*1	Clean fuel tank & filter					○						
	*1	Check idling speed						○		○			Every 300 hours or every year whichever comes earlier
	*1	Check valve clearance						○		○			Every 300 hours or every year whichever comes earlier
	*1	Remove carbon in combustion chamber							○				
	*1	Check fuel hoses and clamp bands									○		
	*2	Replace engine oil				▲		△					
	*2	Replace air cleaner element							△		△		Paper filter element: Every 300 hours or every year whichever comes earlier Foam filter element: As necessary
	*2	Replace spark plug							△		△		Every 300 hours or every year whichever comes earlier
*1	Replace fuel hoses and clamp bands											△	
Driving section		Check electrical wiring					○	○					
		Adjust engine clutch spring										○	
		Adjust engine clutch clearance										○	
		Replace brake wire											△
		Replace throttle wire											△

Appended Table

Maintenance Item		Before Work	After Work	Every 10 hrs.	Every 25 hrs.	Every 50 hrs.	Every 100 hrs.	Every 300 hrs.	Every 500 hrs.	Every year	Every 2 years	When Required	Remarks	
Driving section	Replace main clutch wire											△		
	Check blade engagement	○												
	Check mowing height	○												
	Check groomer height	○												
Cutting section	Grease			○	○								Maintenance schedules differ according to greasing points	
	Clean and grease bedknife eccentric bushes								○	○			Every 500 hours or every year whichever comes earlier, and when replacing a bedknife additionally.	
	Backlap blades											○		
	Engage blades											○		
	Adjust mowing height											○		
	Adjust groomer											○		
	Adjust cutter adjustment spring											○		
	Regrind reel cutter											○	Grind/Replace blades as and when required	
	*1	Replace bearings inside gearcase										△		
	*1	Replace front/rear roller bearings										△		
	*1	Replace grass catcher roller bearings										△		
	*1	Replace oil seals inside gearcase										△		
	*1	Replace front/rear roller oil seals										△		
	*1	Replace grass catcher roller oil seals										△		
*1	Replace grease inside gearcase										△			

Appended Table

- *1: Consult your local Baroness Dealer for this service.
- *2: Refer to the Engine's Owner's Manual.
- The values for consumables are not guaranteed.

Appended Table

List of Adjusted Values

Cutter adjustment spring	50 mm (1.97 in)	Length of coil spring
Reel cutter shaft bearing preload spring	11.5 mm (0.453 in)	Total length of spring
Reel cutter rotation torque	0.8 - 1.0 N · m (8 - 10 kgf · cm)	
Engine clutch	0.5 - 1.0 mm (0.020 - 0.039 in)	Clearance between engine clutch and clutch facing
Operation distance of clutch plate	1 - 2 mm (0.039 - 0.079 in)	
Engine clutch spring	63 mm (2.48 in)	Total length of spring

Appended Table

Troubleshooting Procedures of Aftercut Appearance

Scalping

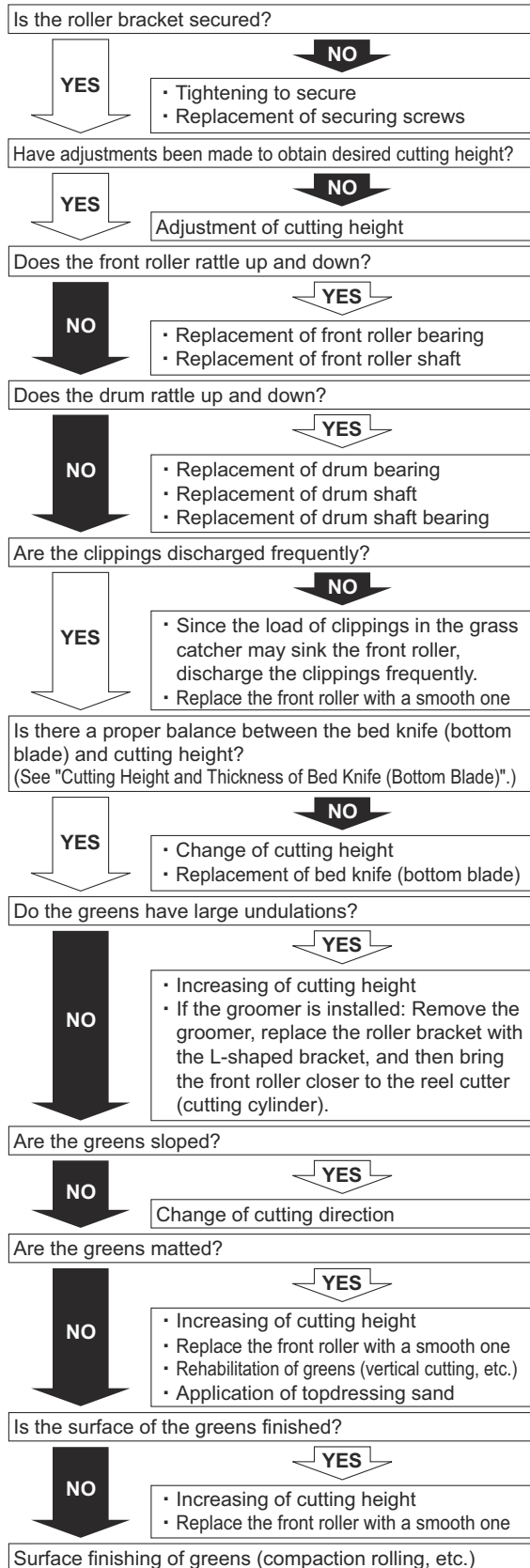

iuwt3m-004E

Scalping_001

Angled Mismatch

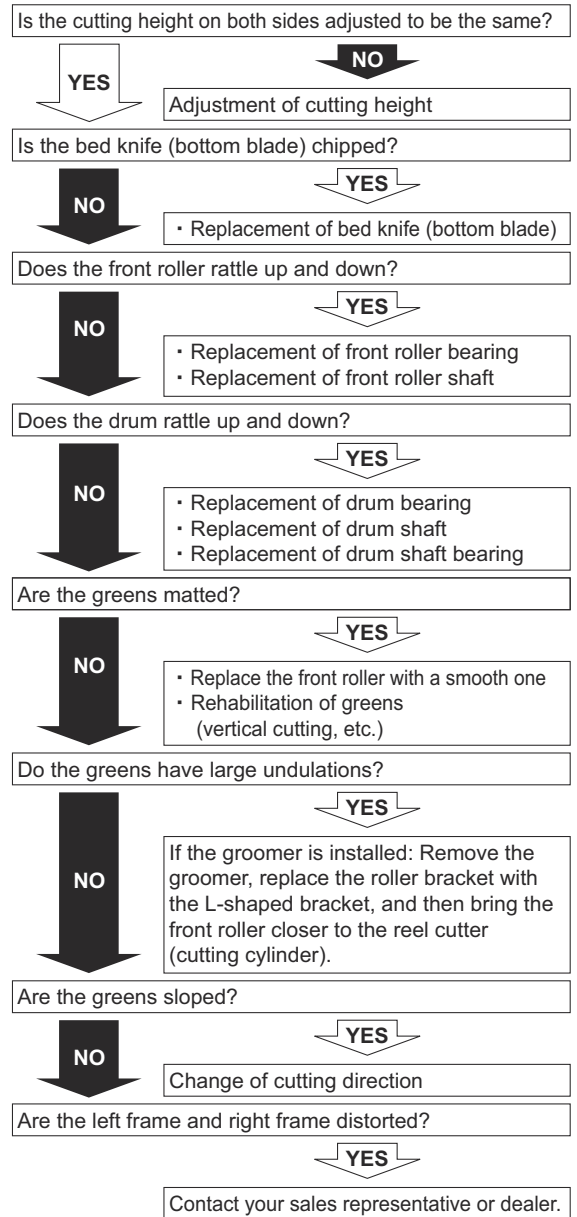

7x9s4e-001E

Angled Mismatch_001

Appended Table

Overlap Marks

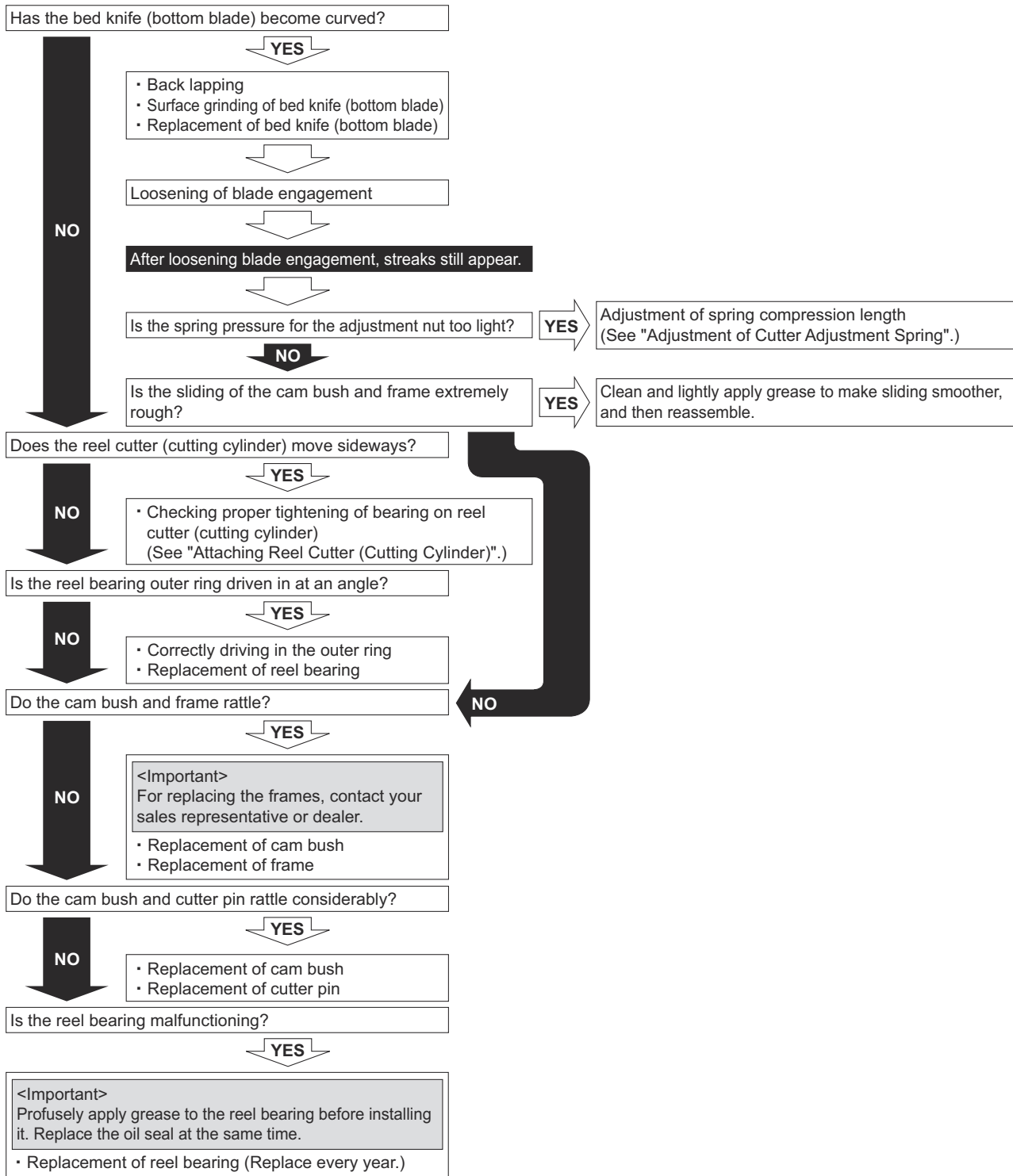

Appended Table

Blade Does Not Cut

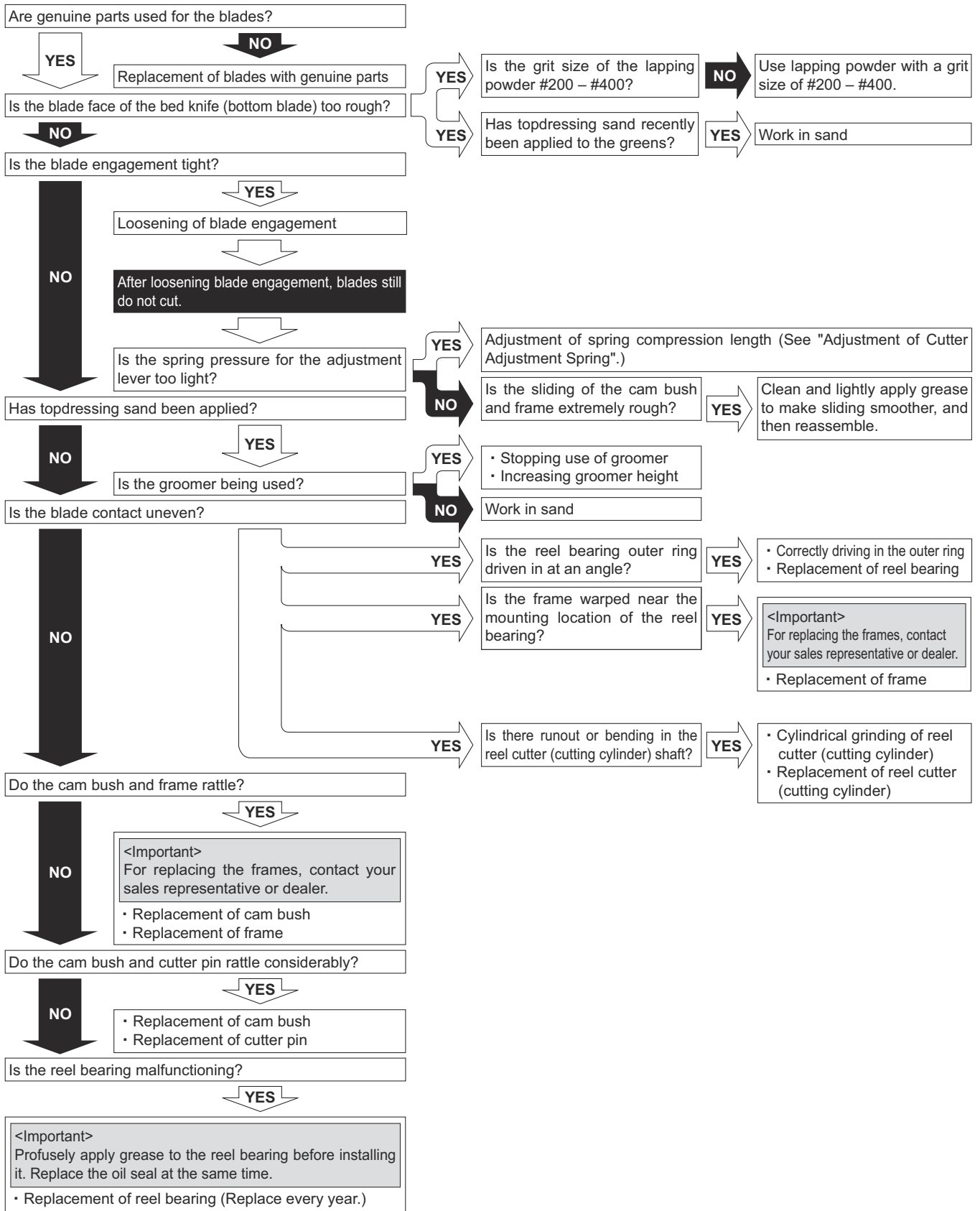

Appended Table

Appended Table

Uneven Blade Engagement

The unevenness is a difference of tightening torque between the left and right cutter adjustment nuts, or blade engagement on only one side, which cannot be adjusted.

Promptly resolve the issue in order to maintain the optimum performance of the machine.

Cause of unevenness	Measure to resolve
Asymmetrical wear of reel cutter (cutting cylinder)	Cylindrical grinding of reel cutter (cutting cylinder) Replacement of reel cutter (cutting cylinder)
Asymmetrical wear of bed knife (bottom blade)	Surface grinding of bed knife (bottom blade) Replacement of bed knife (bottom blade)
Distortion of frames	Rearrange frames in parallel

Important

Depending on the extent of the symptoms, they may not be resolved.

Important

Performing temporary measures may cause the symptoms to progress, resulting in cutting issues.

Temporary measures:

- Adjustment with cam bushes
"Adjustment of CAM" (Page 6-15)
- Adjustment of spring pressure
"Adjustment of Cutter Adjustment Spring" (Page 6-15)

Records

Daily Check Records Page 9-2

Maintenance RecordsPage 9-5

Records

Records

Daily Check Records

LM18GC/LM56GC/LM66GC/LM66TC

Use this table freely for your records of the daily check.

Model								Serial Number			
Items											
Engine (Honda)	Check engine oil										
	Check fuel										
	Check fuel strainer										
	Check oil or water leaks										
	Check air cleaner										
	Check bolts and nuts										
	Check engine area										
	Clean engine area										
Driving section	Check tire										
	Check machine exterior										
	Check bolts and nuts										
	Check main clutch lever										

Records

Items											
Driving section	Check clutch lock lever										
	Check cover										
	Check brake										
	Check wire										
	Check light										
	Clean machine exterior										
Cutting section	Check reel cutter and bed knife										
	Check cover										
	Check roller										
	Check drum										
	Check groomer										
	Check grass catcher										
	Check cutting section										
	Check bolts and nuts										

Records

Records

Items											
Cutting section	Clean cutting section										

Maintenance Records

LM18GC/LM56GC/LM66GC/LM66TC

Use this table freely for your records of the maintenance.

Model		Serial Number								
Engine	Check spark plug									
	Clean air cleaner element									
	Clean spark arrester									
	Clean sediment cup									
	Clean fuel tank & filter									
	Check idling speed									
	Check valve clearance									
	Remove carbon in combustion chamber									
	Check fuel hoses and clamp bands									
	Replace engine oil									
	Replace air cleaner element									
	Replace spark plug									

Records

Records

Items											
Engine	Replace fuel hoses and clamp bands										
Driving section	Check electrical wiring										
	Adjust engine clutch spring										
	Adjust engine clutch clearance										
	Replace brake wire										
	Replace throttle wire										
	Replace main clutch wire										
Cutting section	Check blade engagement										
	Check mowing height										
	Check groomer height										
	Grease										
	Clean and grease bedknife eccentric bushes										
	Backlap blades										
	Engage blades										

Records

Items											
Cutting section	Adjust mowing height										
	Adjust groomer										
	Adjust cutter adjustment spring										
	Regrind reel cutter										
	Replace bearings inside gearcase										
	Replace front/rear roller bearings										
	Replace grass catcher roller bearings										
	Replace oil seals inside gearcase										
	Replace front/rear roller oil seals										
	Replace grass catcher roller oil seals										
	Replace grease inside gearcase										

Records

Records

BARONESS[®]
Quality on Demand

 **KYOEISHA CO., LTD.**
Head Office 1-26, Miyuki-cho, Toyokawa-city, Tel :+81-533-84-1390
Aichi-pref, 442-8530 JAPAN Fax:+81-533-84-1220