

# ***LM101***

Floating Head Greens Mower

## Owner's Operating Manual

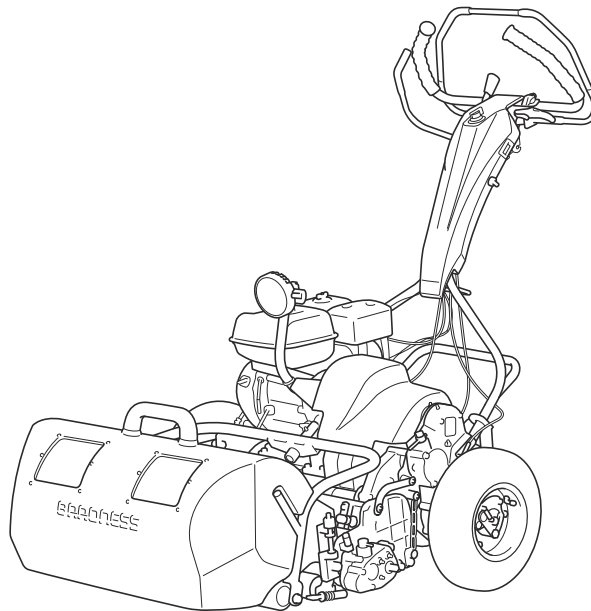

Serial No. LM101 : 10906-

"Required reading"  
Read this manual before using the machine.

---

**BARONNESS**<sup>®</sup>  
Quality on Demand

Original Instructions Ver.3.1

LM101

# Regulations

---

## EU Regulations

(For EU)

This product complies with all relevant EU Regulations.

For more information, please refer to the Declaration of Conformity attached.

Thank you for purchasing the Baroness product.  
This manual describes the proper handling,  
adjustment, and inspection of your product.  
We hope you will use the product safely, and take  
advantage of its best performance.

## QR Code

(\*QR Code is a registered trademark of DENSO  
WAVE INCORPORATED.)

A QR code label is affixed on the machine.

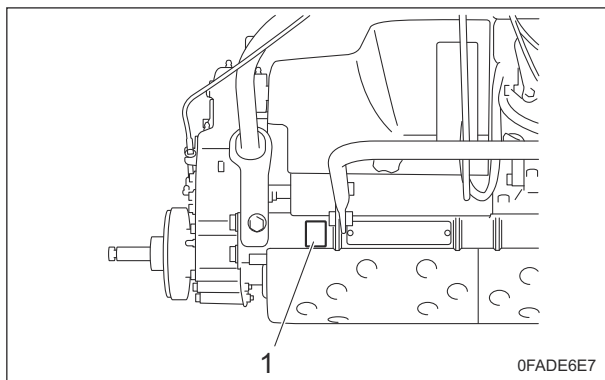

QR Code\_001

1	QR code label
---	---------------

Scan the QR code with your smartphone for  
easy access to Baroness Manual Reference  
Service where you can browse Owner's  
Operating Manual and Parts Catalog.  
[https://doc.baroness-international.com/manuals/  
LM101](https://doc.baroness-international.com/manuals/LM101)



QR Code\_002

# Introduction

---

Read this manual carefully to ensure that you thoroughly understand how to properly operate and maintain the product, and to avoid causing injury to yourself or others.

The operator is responsible for operating the product properly and safely.

Maintenance service for this machine should be performed by a mechanic with expertise.

If you have any questions concerning maintenance or genuine parts, please contact a Baroness dealer or Kyoisha.





When making inquiries about your product, please specify the model and serial number.

When loaning or transferring the product, please also provide this manual together with the product.

Kyoeisha Co., Ltd.

## Warning Symbols

This manual uses the following warning symbols for handling precautions that are important for your safety.

 <small>696cq5-001</small>	Warning symbol
<p>This symbol indicates the articles regarding “Danger,” “Warning,” or “Caution.” Those articles describe important safety precautions and so read them carefully to understand completely before operating the machine.</p> <p>Failure to adequately follow these safety precautions may cause an accident.</p>	
<p><b> Danger</b></p> <p>This symbol indicates that serious injury or death will occur if the warning is ignored.</p>	
<p><b> Warning</b></p> <p>This symbol indicates that serious injury or death may occur if the warning is ignored.</p>	
<p><b> Caution</b></p> <p>This symbol indicates that injury or damage to property may occur if the warning is ignored.</p>	
<p><b>Important</b></p> <p>This symbol indicates precautions on the mechanism of the machine.</p>	

## Precautionary Statement

 Caution

The information described in this manual is subject to change for improvement without prior notice.

When replacing parts, be sure to use genuine Baroness parts or parts designated by Kyoeshia.

Note that the Baroness product warranty may not apply to defects caused by the use of parts from other companies.

Prior to use, carefully read the following manuals to thoroughly understand the contents for safe and correct operation.

- Baroness Owner's Operating Manual
- The Engine's Owner's Manual

## Purpose

This machine is intended for cutting turf grass at golf courses.

Do not use this machine in any way other than its intended purpose, and do not modify the machine.

Operating this machine for other purposes and modifying it may be very dangerous and may cause damage to the machine.

LM101

# Introduction

---

<b>Safety</b> .....	<b>Page 1-1</b>	Greasing .....	Page 6-5
Safe Operating Practices .....	Page 1-2	Lubrication .....	Page 6-10
<b>Disposal</b> .....	<b>Page 2-1</b>	Adjustment .....	Page 6-11
Recycle and Waste Disposal .....	Page 2-2	Replacement .....	Page 6-23
<b>Product Overview</b> .....	<b>Page 3-1</b>	Storage .....	Page 6-32
Specifications .....	Page 3-2	<b>Repair</b> .....	<b>Page 7-1</b>
Names of Each Section .....	Page 3-4	Precautions for Repair .....	Page 7-2
Regulation Decals .....	Page 3-5	Adjustment .....	Page 7-2
Safety Signs and Instruction Signs .....	Page 3-6	<b>Appended Table</b> .....	<b>Page 8-1</b>
Operation Decals .....	Page 3-9	Tightening Torques .....	Page 8-2
<b>Description of Functions</b> .....	<b>Page 4-1</b>	Daily Check List .....	Page 8-5
Light Switch .....	Page 4-2	Maintenance Schedule .....	Page 8-6
Engine Switch .....	Page 4-2	List of Adjusted Values .....	Page 8-8
Throttle Lever .....	Page 4-2	Troubleshooting Procedures of Aftercut Appearance .....	Page 8-9
Throttle Lever .....	Page 4-2	<b>Records</b> .....	<b>Page 9-1</b>
Brake Lever .....	Page 4-3	Daily Check Records .....	Page 9-2
Clutch Lock Lever .....	Page 4-3	Maintenance Records .....	Page 9-5
Main Clutch Lever .....	Page 4-3		
Drum Clutch Lever .....	Page 4-4		
Unit Clutch Lever .....	Page 4-4		
FOC (High/Low Clip) Selector Lever .....	Page 4-4		
Engine Clutch Cover .....	Page 4-5		
Groomer Clutch Lever .....	Page 4-5		
Instruments .....	Page 4-6		
<b>Handling Instructions</b> .....	<b>Page 5-1</b>		
Operations before Service .....	Page 5-2		
Preparation for Use .....	Page 5-2		
Inspection before Use .....	Page 5-3		
Start/Stop of Engine .....	Page 5-8		
Parking and Stopping .....	Page 5-10		
Move .....	Page 5-10		
Cutting Work .....	Page 5-11		
Transporting .....	Page 5-13		
Cleaning after Use .....	Page 5-13		
Storage .....	Page 5-13		
<b>Maintenance</b> .....	<b>Page 6-1</b>		
Precautions for Maintenance .....	Page 6-2		
Position of Mower during Maintenance .....	Page 6-2		
Inspection and Cleaning .....	Page 6-3		
Supplying Fluids .....	Page 6-5		

LM101

# Contents

---

**Safe Operating Practices ..... Page 1-2**

Training ..... Page 1-2

Preparation ..... Page 1-2

Operation ..... Page 1-3

Maintenance ..... Page 1-4

Storage ..... Page 1-4



# Safety

Failure to adequately follow these safety precautions may cause an accident resulting in injury or death.

## Danger

This product is designed to ensure safe operation and has been tested and inspected thoroughly before shipment from the factory. The product is equipped with safety devices to prevent accidents.

However, whether the product demonstrates its original performance level depends on the manner in which it is operated and handled, as well as the manner in which it is managed on a daily basis.

Inappropriate use or management of the product may result in injury or death.

Observe the following safety instructions to ensure safe operation.

## Safe Operating Practices

### Training

1. Read this manual and other training material carefully.  
Be familiar with the controls, safety signs, and the proper use of the equipment.
2. If the operator or mechanic can not read the language used in this manual, it is the owner's responsibility to explain this material to them.
3. All operators and mechanics should seek and obtain professional and practical instruction.  
The owner is responsible for training the users.
4. Never allow people unfamiliar with these instructions to use or service the machine.  
Local regulations may restrict the age of the operator.
5. The owner/user can prevent and is responsible for accidents or injuries occurring to themselves, other people, or property.
6. Keep in mind that the owner, operator, and mechanic are responsible for accidents or hazards occurring to other people or their property.
7. You can find additional safety information where needed throughout this manual.
8. Determine the left and right sides of the machine from the normal operating position.

### Preparation

1. Evaluate the terrain to determine what accessories and attachments are needed to properly and safely perform the job.  
Only use accessories and attachments approved by the manufacturer.
2. While operating, always wear substantial footwear, long trousers, hard hat, safety glasses, mask, and ear protection.  
Long hair, loose clothing, or jewelry may get tangled in moving parts.  
Do not operate the equipment when barefoot or wearing open sandals.
3. Inspect the area where the equipment is to be used and remove all objects such as rocks, toys and wire which can be thrown by the machine.
4. Keep children out of the operating area and under the watchful care of a responsible adult other than the operator.
5. Exercise care in the handling of fuel.

## Warning

Fuel is highly flammable.  
Take the following precautions:

- [1] Store fuel in containers specifically designed for this purpose.
- [2] Add fuel before starting the engine.  
Never remove the cap of the fuel tank or add fuel while the engine is running or when the engine is hot.
- [3] Refuel outdoors only and do not smoke while refueling.
- [4] If fuel is spilled, do not attempt to start the engine but move the machine away from the area of spillage and avoid creating any source of ignition until petrol vapours have dissipated;
- [5] Replace all fuel tanks and container caps securely.
6. Check that operator's presence controls, safety switches and shields are attached and functioning properly.  
Do not operate unless they are functioning properly.
7. If the brake operation is faulty, be sure to adjust or repair them before operating the machine.

8. If the handlebar has noticeable play, be sure to adjust or repair them before operating the machine.
9. Replace faulty mufflers.

## Operation

1. Do not use the machine while you are tired or under the influence of drugs, alcohol or medication.  
A moment of inattention while operating the machine may result in serious personal injury.
2. Do not operate the engine in a confined space where dangerous carbon monoxide fumes can collect.
3. Be sure all drives are in neutral and parking brake is engaged before starting engine.
4. Start the engine or switch on the motor carefully according to this manual and with feet well away from the cutting section.
5. Do not change the engine governor settings or overspeed the engine.  
Operating the engine at excessive speed may increase the hazard of personal injury.
6. Pay attention not to touch hot parts.
7. Never operate the machine with damaged guards, shields, or without safety protective devices in place.  
Be sure all interlocks are attached, adjusted properly, and functioning properly.
8. Keep hands and feet away from the rotating parts.
9. Never pick up or carry the machine in operation.
10. Never operate while people, especially children, or pets are nearby.
11. Only operate in good light, keeping away from holes and hidden hazards.
12. Do not operate the machine when there is the risk of lightning.
13. Do not operate the machine in rain or wet conditions.  
This may increase the risk of electric shock.
14. Walk, never run.
15. Do not stop or start suddenly.
16. Avoid operating the equipment in wet grass, where feasible.
17. Look behind and down before backing up to be sure of a clear path.
18. Slow down and use caution when making turns and crossing roads and sidewalks.
19. Use care when approaching blind corners, shrubs, trees, or other objects that may obscure vision.
20. Do not take your eyes off the road ahead.  
Do not operate the machine with no hands.
21. Always be sure of your footing on slopes.
22. Remember there is no such thing as a safe slope.  
Travel on grass slopes requires particular care.  
To guard against overturning, follow these instructions.
  - [1] Do not operate the machine on excessively steep slopes.
  - [2] Do not stop or start suddenly when going up or downhill.
  - [3] Engage clutch slowly, always keep machine in gear, especially when traveling downhill.
  - [4] Machine speeds should be kept low on slopes and during turns.
23. Use extra care while operating machine with a grass catcher or other attachments.  
They can affect the stability of the machine.
24. Disengage drive to the cutting section, when other than operating.
25. Do the following before leaving the operator's position.
  - [1] Stop on level ground.
  - [2] Disengage the all drives.
  - [3] Set the parking brake.
  - [4] Stop the engine.
26. Stop the engine in the following conditions.
  - [1] Before refuelling.
  - [2] Before removing the grass catcher.
  - [3] Before making height or depth adjustment unless adjustment can be made from the operator's position.
  - [4] Before clearing blockages.
  - [5] Before checking, cleaning or working on the machine.
  - [6] After striking a foreign object or if an abnormal vibration occurs.  
Inspect the machine for damage and make repairs before restarting and operating the equipment.
27. Reduce the throttle setting during engine run-out.

# Safety

---

28. Do not direct discharge material toward anyone.  
Avoid discharging material against a wall or obstruction.  
Material may ricochet back toward the operator.
29. Take care when loading or unloading the machine into a trailer or a truck.  
Load or unload the machine in a flat and safe place.  
Before loading or unloading, set the parking brake on the truck or trailer, stop the engine, and chock the wheels.  
When transporting the machine on a truck or a trailer, set the parking brake, stop the engine, and fasten the machine to the truck with a rope or other suitable restraining device that has sufficient strength.  
When using a running board, select one with sufficient strength, length, and width and that will not cause the machine to slip.
30. Close the fuel valve before transporting the machine.
8. Make sure that parts such as wires are not touching each other and that their covers have not come off.
9. Keep all parts in good working condition and all hardware tightened.  
Replace all worn or damaged decals.
10. Keep all nuts, bolts and screws tight to be sure the equipment is in safe working condition.
11. Carefully release pressure from components with stored energy.
12. Use care when checking the cylinders/reels and bed knives.  
Wear gloves and use caution when servicing them.
13. Be careful during adjustment of the machine to prevent entrapment of the fingers between moving blades and fixed parts of the machine.
14. Check the grass catcher frequently for wear or deterioration.
15. If the fuel tank has to be drained, do this outdoors.

## Maintenance

1. Never allow untrained personnel to service machine.
2. Implement the following work before adjusting, cleaning or repairing.
  - [1] Stop the machine on level ground.
  - [2] Disengage drive to the cutting section.
  - [3] Set the parking brake.
  - [4] Stop the engine.
  - [5] Disconnect spark plug wire.
  - [6] Wait for all movement to stop.
3. Allow the engine/muffler to cool before checking/maintenance.
4. To reduce the fire hazard, keep hot parts such as the engine and silencer/muffler, and fuel storage area free of grass, leaves, or excessive grease.  
Clean up oil or fuel spillage.
5. Appropriately manage and correctly use the tools necessary for servicing or adjusting the machine.
6. Use jack stands to support components when required.
7. Keep hands and feet away from moving parts.  
If possible, do not make adjustments with the engine running.

## Storage

1. Allow the engine to cool before storing in any enclosure.
2. Only cover the machine with a sheet after hot parts have sufficiently cooled down.
3. Never store the equipment with fuel in the tank inside a building where fumes may reach an open flame or spark.
4. If the engine is provided with a shut-off valve, shut off valve while storing or transporting.
5. Do not store fuel near flames.

**Recycle and Waste Disposal ..... Page 2-2**

About Recycle .....Page 2-2

About Waste Disposal ..... Page 2-2

Disposal

# Disposal

---

## Recycle and Waste Disposal

### About Recycle

Recycling battery etc. is recommended for environmental conservation and economical use of resources.

It may be required by local laws.

### About Waste Disposal

Make sure that waste generated when servicing or repairing the machine is disposed of in accordance with local regulations. (e.g. waste oil, antifreeze, rubber products, and wires etc.)

**Specifications ..... Page 3-2**

Specifications .....Page 3-2

Sound Pressure Level ..... Page 3-3

Sound Power Level ..... Page 3-3

Vibration Level .....Page 3-3

Carbon Dioxide (CO<sub>2</sub>) Emissions .....Page 3-3**Names of Each Section ..... Page 3-4****Regulation Decals .....Page 3-5**

Positions of Regulation Decals ..... Page 3-5

Description of Regulation Decals ..... Page 3-5

**Safety Signs and Instruction Signs ..... Page 3-6**About Safety Signs and Instruction  
Signs .....Page 3-6Positions of Safety Decals and  
Instruction Decals ..... Page 3-6Description of Safety Decals and  
Instruction Decals ..... Page 3-7**Operation Decals ..... Page 3-9**

Positions of Operation Decals ..... Page 3-9

Description of Operation Decals ..... Page 3-9

# Product Overview

## Specifications

### Specifications

Model		LM101	
Name		Floating Head Greens Mower	
Dimensions	Total length	with grass catcher	141 cm 55.51 in
	Total width	without traveling wheel	94 cm 37.01 in
	Total height	Steering handle	117 cm 46.06 in
Weight	Machine (empty fuel tank)		114 kg 251.32 lb
	Grass catcher* <sup>1</sup>		3.3 kg 7.28 lb
	Groomer* <sup>1</sup>		3.6 kg 7.94 lb
	Traveling wheel (for one machine)* <sup>1</sup>		6.9 kg 15.21 lb
Minimum turning radius		-	
Engine	Model		HONDA GX120
	Type		Gasoline air-cooled engine (OHV) four-stroke single-cylinder
	Total displacement		122 cm <sup>3</sup> (0.122 L) 7.44 cu.in.
	Maximum output		2.4 kW (3.3 PS)/3,600 rpm
	Rated output		2.1 kW (2.9 PS)/3,600 rpm
Fuel tank capacity		Gasoline 2.0 dm <sup>3</sup> (2.0 L)	Gasoline 0.53 U.S.gals
Fuel consumption		338 g/kW · h (rated output)	248.60 g/PS · h (rated output)
Engine oil capacity		0.56 dm <sup>3</sup> (0.56 L)	0.15 U.S.gals
Coolant volume		-	
Hydraulic tank capacity		-	
Transmission oil capacity		-	
Operating width (Mowing width)		55.7 cm	22 in
Operating height (Mowing height)		3.0 - 14.0 mm [3.0 - 12.5 mm] <sup>*2</sup>	0.118 - 0.551 in [0.118 - 0.492 in] <sup>*2</sup>
Number of Blades		9, 11	
Drive	Traveling	Mechanical	
	Mowing	Mechanical	
Speed (HST)		-	
Speed (Mechanical)		4.7 km/h (@3,000 rpm)	2.92 mph (@3,000 rpm)
Efficiency		2,094 m <sup>2</sup> /h (4.7 km/h x mowing width x 0.8)	0.52 acres/hour (2.92 mph x mowing width x 0.8)
Maximum inclination for operation		-	
Tire size		4.10/3.50 - 6	
Tire pneumatic pressure		120 kPa (1.2 kgf/cm <sup>2</sup> )	17 psi
Battery		-	
Engine plug		NGK BPR4ES	

The factory default maximum engine rpm is 3,100 rpm.

\*1: Weight (Machine) includes \*1 parts.

\*2: The indicated lowest mowing height is for general application. It may be adjusted according to the state of green and the bed knife to be installed.

The value in the brackets [ ] is the mowing height of the machine equipped with a groomer.

## Sound Pressure Level

### Sound Pressure Level

This machine was confirmed to have a continuous A-weighted sound pressure level of 84 dB by measuring identical machines in accordance with the procedure specified in ISO5395-1:2013.

## Sound Power Level

### Sound Power Level

This machine was confirmed to have a sound power level of 98 dB by measuring identical machines in accordance with the procedure specified in ISO5395-1:2013.

## Vibration Level

### Hand-Arm Vibration

This machine was confirmed not to exceed a vibration level of 2.5 m/s<sup>2</sup> to hands and arms by measuring identical machines in accordance with the procedure specified in ISO 5395-1:2013.

## Carbon Dioxide (CO<sub>2</sub>) Emissions

For the CO<sub>2</sub> values on Honda engine, refer to the following website.

<http://www.honda-engines-eu.com/co2-engines>

This CO<sub>2</sub> measurement results from testing over a fixed test cycle under laboratory conditions of a(an) (parent) engine representative of the engine type (engine family) and shall not imply or express any guarantee of the performance of a particular engine.

# Product Overview

## Names of Each Section

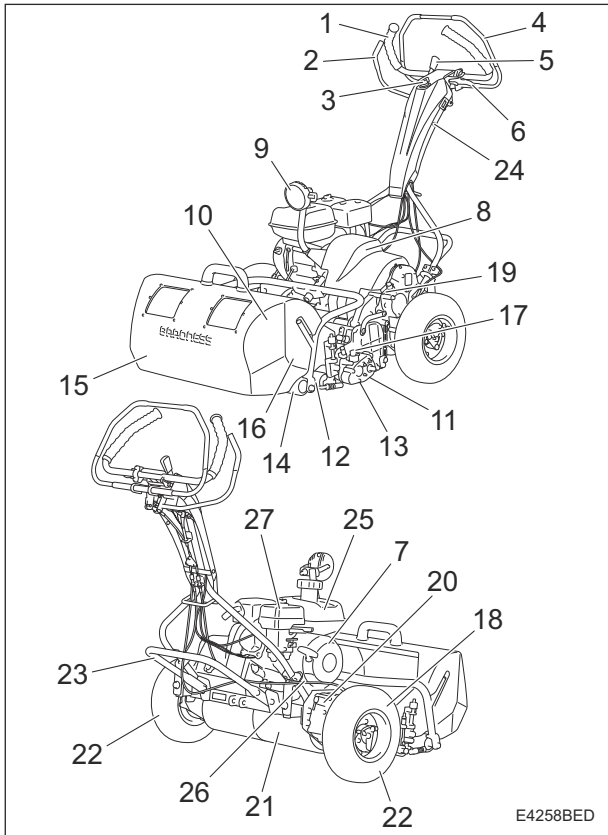

Names of Each Section\_001

1	Handle
2	Throttle lever
3	Engine switch
4	Main clutch lever
5	Clutch lock lever
6	Brake lever
7	Engine
8	Engine clutch cover
9	Light
10	Reel cutter
11	Bed knife
12	Front roller
13	Rear roller
14	Grass catcher roller
15	Grass catcher
16	Groomer
17	Groomer clutch lever
18	FOC (High/Low Clip) selector lever
19	Unit clutch cover
20	Drum clutch cover
21	Drum
22	Traveling tires
23	Stand
24	Light switch
25	Fuel tank
26	Fuel strainer
27	Air cleaner

## Regulation Decals

### Positions of Regulation Decals

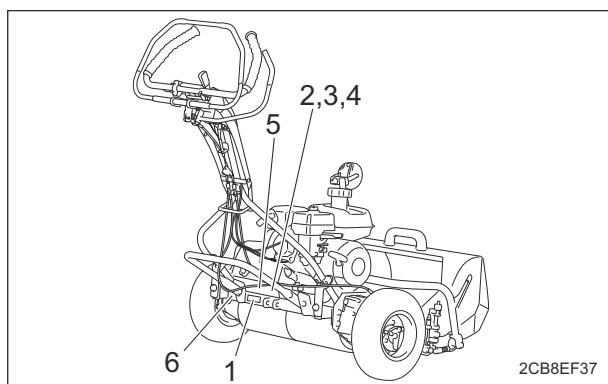

Positions of Regulation Decals\_001

1	Serial number plate
2	Specification decal
3	CE mark
4	UKCA mark (#10761 - 10885)
5	Noise emission decal
6	Year of manufacture decal

### Description of Regulation Decals

#### Serial Number Plate

The following information is written on the serial number plate.

1. Model
2. Serial number
3. Registered trademark
4. Manufacturer
  - Company name
  - Postal address/Address
  - Website
 Contact the manufacturer via the contact form on the website.



Serial Number Plate\_001

#### Specification Decal

(For EU)  
The Specification decal indicates the model and weight, etc.

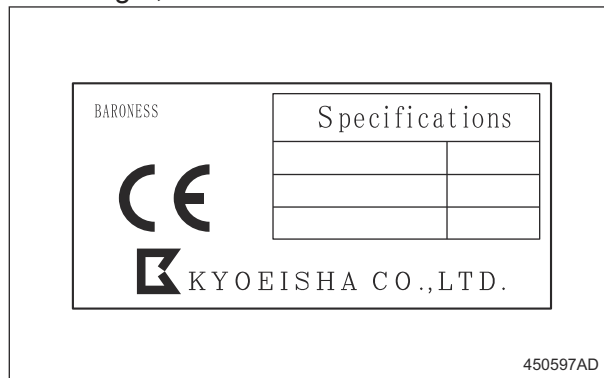

Specification Decal\_001

#### CE Mark

(For EU)  
CE mark indicates that the machine sold in the EU nations complies with the EU requirements.

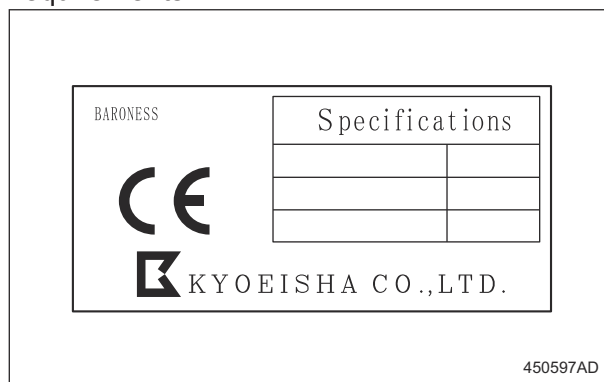

CE Mark\_001

#### UKCA Mark

(For UK)  
UKCA mark indicates that the machine sold in the UK complies with the UK requirements.



UKCA Mark\_001

# Product Overview

## Noise Emission Decal

(For EU)

The noise emission decal indicates the sound power level determined by measuring identical machines in accordance with the procedure specified in the regulations of EU.

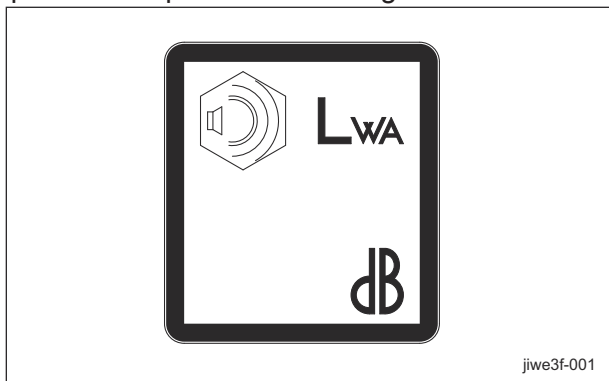

Noise Emission Decal\_001

## Year of Manufacture Decal

(For EU)

The year of manufacture decal indicates the year when this machine was manufactured.

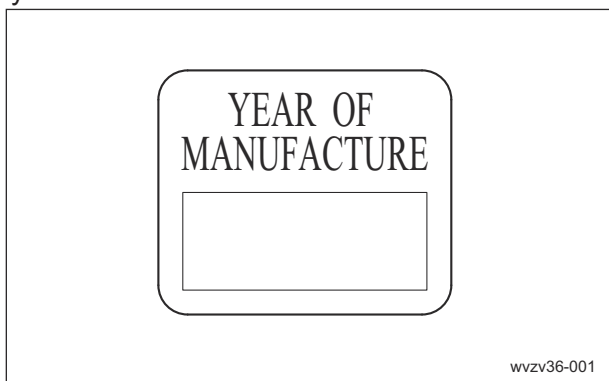

Year of Manufacture Decal\_001

## Safety Signs and Instruction Signs

### About Safety Signs and Instruction Signs

#### Important

Safety decals and instruction decals are attached to this product. Make sure that they are preserved in their entirety. If they are damaged, become dirty, or peel off, replace them with new ones.

Part numbers for decals that need to be replaced are listed in the parts catalog. Order them from a Baroness dealer or Kyoisha.

### Positions of Safety Decals and Instruction Decals

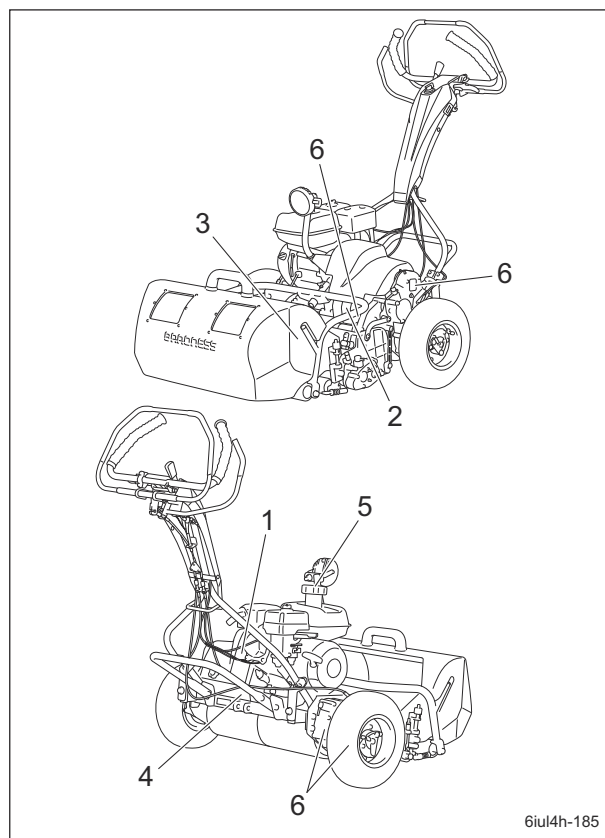

Positions of Safety Decals and Instruction Decals\_001

1	DECAL, CAUTION HANDLING
2	DECAL, CAUTION PTO
3	DECAL, CAUTION TO MUTILATION
4	DECAL, CAUTION TO NOISE
5	DECAL, WARNING ENGINE OIL
6	DECAL, GREASING EACH 10-HOURS

## Description of Safety Decals and Instruction Decals

### Handling Caution Decal

K4205002150  
DECAL, CAUTION HANDLING

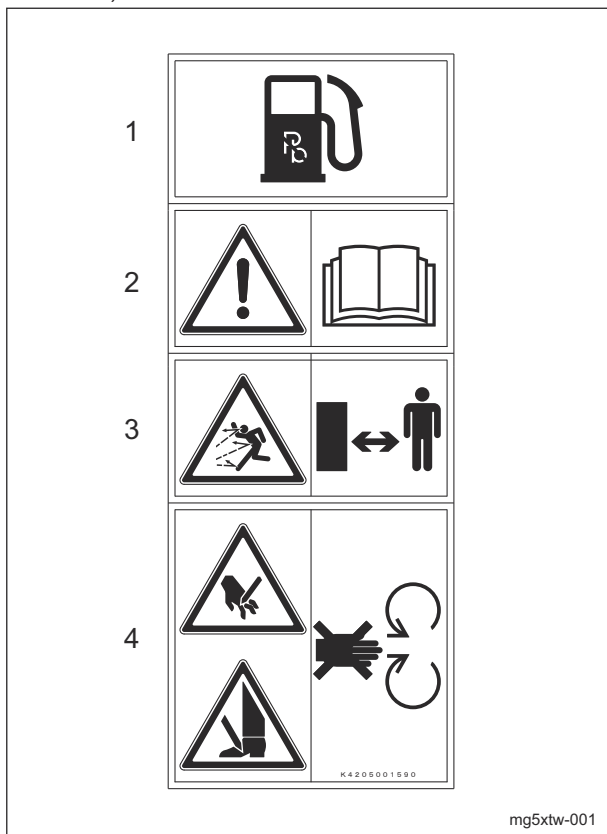

Handling Caution Decal\_001

1. Use lead-free gasoline.

2.

**Warning**

Read the Owner's Operating Manual.

3.

**Caution**

Thrown objects - Be sure that people around the machine keep a safe distance away.

4.

**Warning**

May cut your hand or leg - When the blades are rotating, keep hands and feet away from moving parts.

### PTO Caution Decal

K4205001760  
DECAL, CAUTION PTO

**Warning**

May catch your arm - Keep away from PTO moving parts during the engine running.

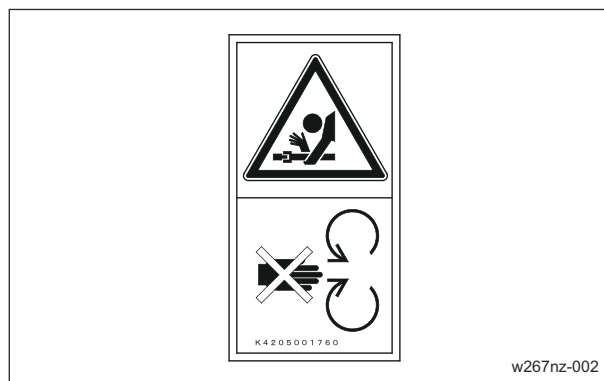

PTO Caution Decal\_001

### Caution to Mutilation Decal

K4205001600  
DECAL, CAUTION TO MUTILATION

**Warning**

May cut your hand or leg - Stop the cutter rotation and engine. Otherwise you may get injured.

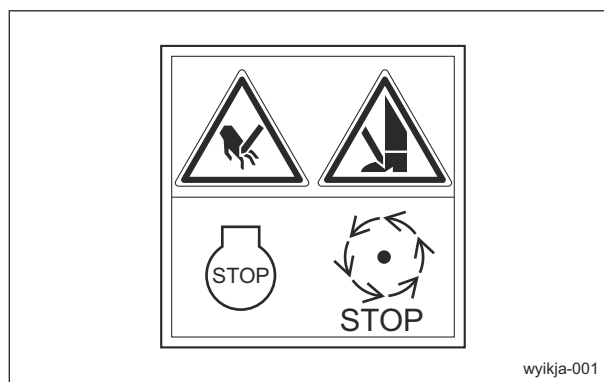

Caution to Mutilation Decal\_001

# Product Overview

---

## Caution to Noise Decal

K4205001330  
DECAL, CAUTION TO NOISE

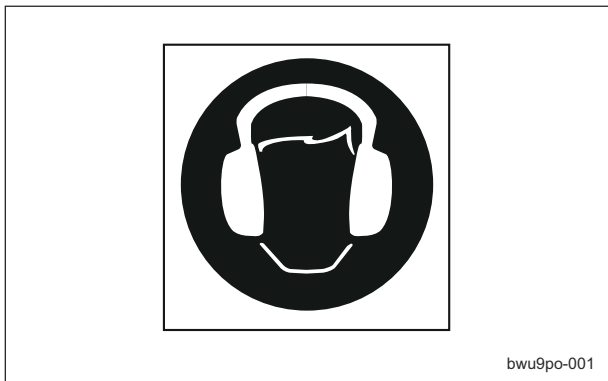

Caution to Noise Decal\_001

## Greasing Each 10-Hours Decal

K4209000370  
DECAL, GREASING EACH 10-HOURS  
Add grease every 10 hours.

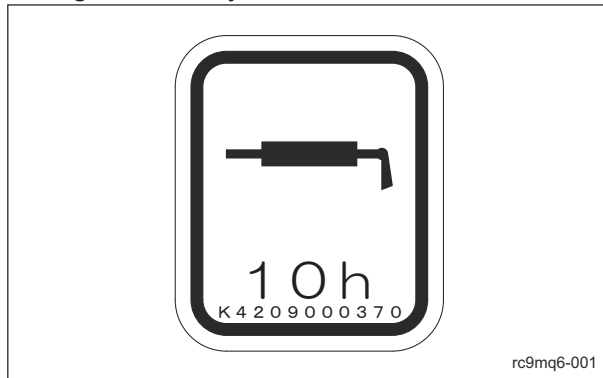

Greasing Each 10-Hours Decal\_001

## Engine Oil Warning Decal

K4205001300  
DECAL, WARNING ENGINE OIL

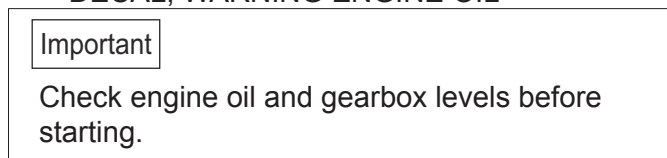

Engine Oil Warning Decal\_001

## Operation Decals

### Positions of Operation Decals

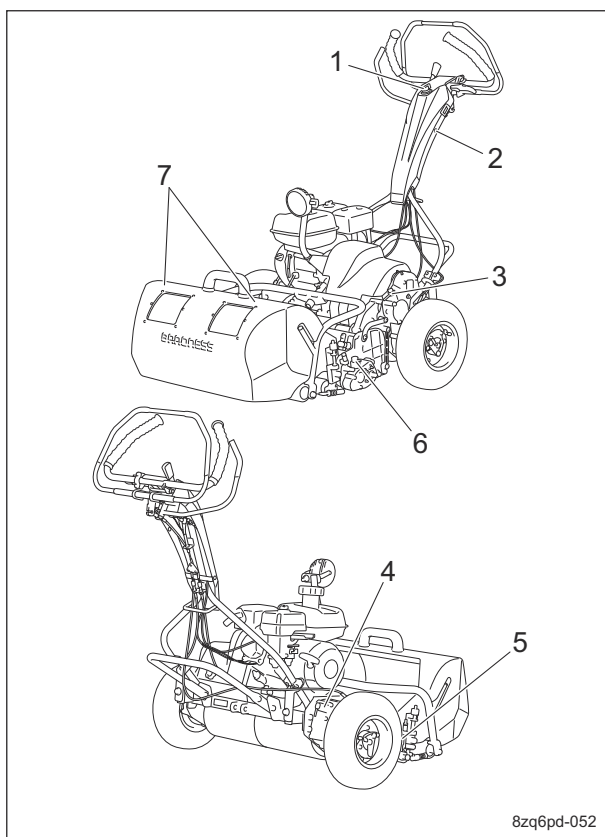

Positions of Operation Decals\_001

1	Engine switch mark
2	Decal, light switch
3	Sticker, ON/OFF A (Unit clutch)
4	Sticker, ON/OFF A (Drum clutch)
5	Sticker, reel rotation
6	Decal, groomer indication
7	Decal, alignment 10300 (Set of 2pcs)

### Description of Operation Decals

#### Engine Switch Mark

**ENGINE SWITCH MARK**  
It illustrates the positions of the engine switch.

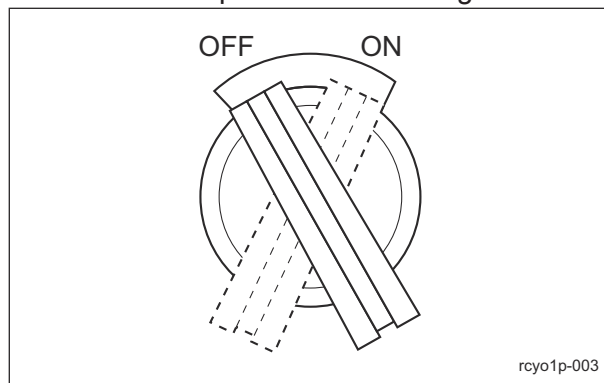

Engine Switch Mark\_001

#### Light Switch Mark

**Note:**  
Depending on the specifications, this function may not be available.  
K4203001610

**DECAL, LIGHT SWITCH**  
It illustrates ON/OFF of the light.

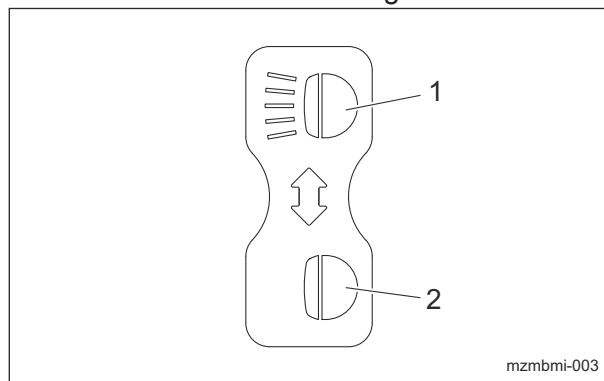

Light Switch Mark\_001

1	ON
2	OFF

# Product Overview

## ON/OFF Mark A (unit clutch)

K4203001140  
 STICKER, ON/OFF A (unit clutch)  
 It shows ON/OFF of the unit clutch.

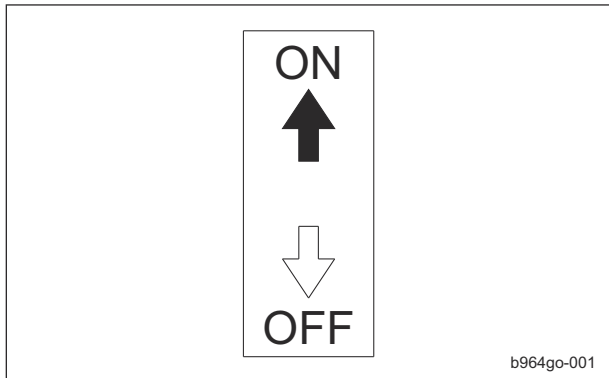

ON/OFF Mark A (unit clutch)\_001

## ON/OFF Mark A (drum clutch)

K4203001140  
 STICKER, ON/OFF A (drum clutch)  
 It shows ON/OFF of the drum clutch.

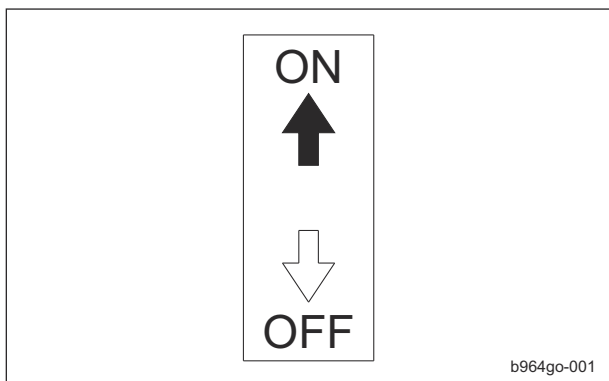

ON/OFF Mark A (drum clutch)\_001

## Reel Rotation Indication Mark

K4203001690  
 STICKER, REEL ROTATION  
 It illustrates High / Low speed of the reel cutter rotation speed.

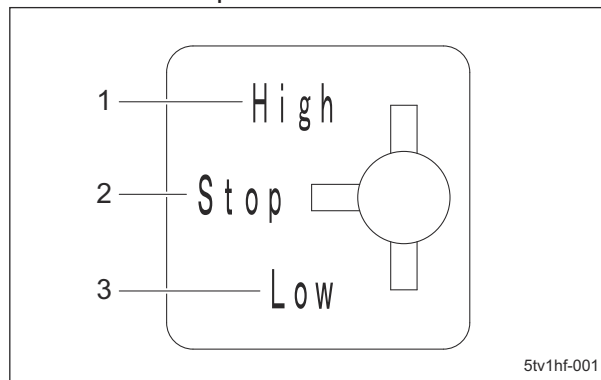

Reel Rotation Indication Mark\_001

1	High speed (High Clip)
2	Stop
3	Low speed (Low Clip)

## Groomer Indication Mark

Note:  
 Depending on the specifications, this function may not be available.

K4203001120  
 DECAL, GROOMER INDICATION  
 It illustrates the changeover of rotational direction of the groomer.

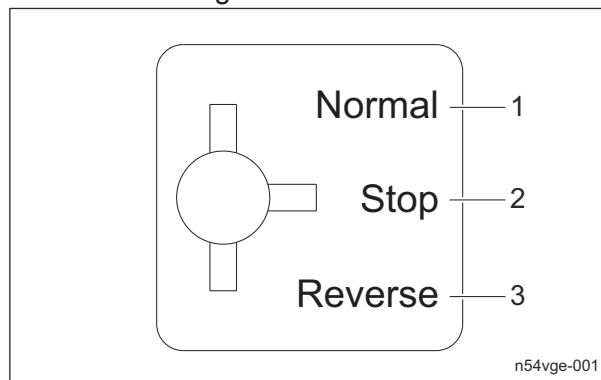

Groomer Indication Mark\_001

1	Normal rotation
2	Stop
3	Reverse rotation

## Red Alignment Mark 10300

## Note:

Depending on the specifications, this function may not be available.

K4209001230

DECAL, ALIGNMENT 10300 (SET OF 2PCS)

Affix the decals in indicative positions on the grass catcher for operational support.

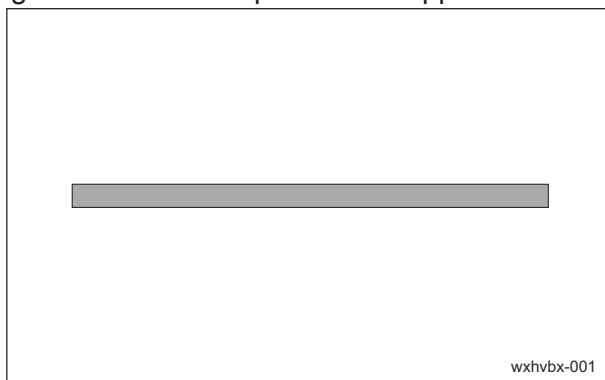

Red Alignment Mark 10300\_001

# Product Overview

---

# Description of Functions

---

<b>Light Switch .....</b>	<b>Page 4-2</b>
<b>Engine Switch .....</b>	<b>Page 4-2</b>
<b>Throttle Lever .....</b>	<b>Page 4-2</b>
<b>Throttle Lever .....</b>	<b>Page 4-2</b>
<b>Brake Lever .....</b>	<b>Page 4-3</b>
<b>Clutch Lock Lever .....</b>	<b>Page 4-3</b>
<b>Main Clutch Lever .....</b>	<b>Page 4-3</b>
<b>Drum Clutch Lever .....</b>	<b>Page 4-4</b>
<b>Unit Clutch Lever .....</b>	<b>Page 4-4</b>
<b>FOC (High/Low Clip) Selector Lever ....</b>	<b>Page 4-4</b>
<b>Engine Clutch Cover .....</b>	<b>Page 4-5</b>
<b>Groomer Clutch Lever .....</b>	<b>Page 4-5</b>
<b>Instruments .....</b>	<b>Page 4-6</b>
Hour Meter .....	Page 4-6

# Description of Functions

## Light Switch

**Note:**  
Depending on the specifications, this function may not be available.  
The light switch is located in the handle panel. Flip up the switch to turn on the light, and down to turn off.

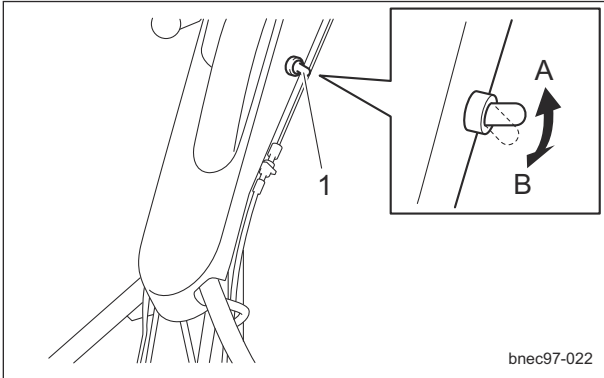

Light Switch\_001

1	Light switch
A	ON
B	OFF

## Engine Switch

The engine switch is located in the handle. To start the engine, set the engine switch to the "ON" position, and to stop it, set to the "OFF" position.

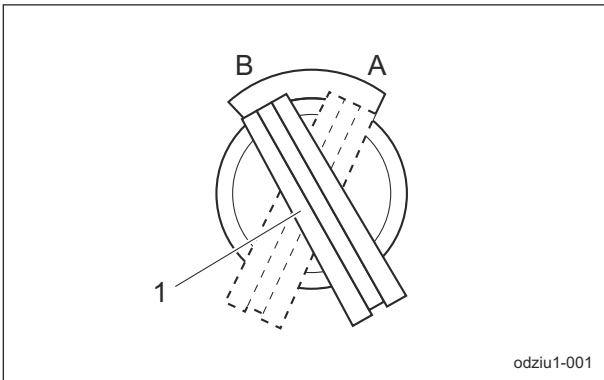

Engine Switch\_001

1	Engine switch
A	ON
B	OFF

## Throttle Lever

**Note:**  
Depending on the specifications, this function may not be available.  
The throttle lever is located in the handle and enables you to adjust the engine rpm. Grip the throttle lever tightly to move it toward "High speed" position for increasing the engine rpm, and loosen grip to move it toward "Low speed" position for decreasing the rpm.

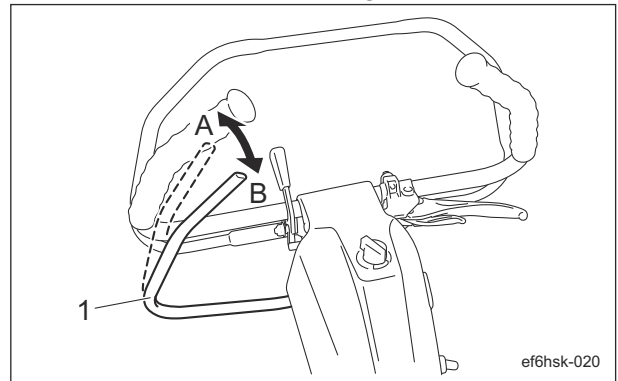

Throttle Lever\_001

1	Throttle lever
A	High speed
B	Low speed

## Throttle Lever

**Note:**  
Depending on the specifications, this function may not be available.  
The throttle lever is located in the handle and enables you to adjust the engine rpm. Move the throttle lever toward the "High speed" position to increase the engine rpm, and toward the "Low speed" position to reduce the rpm.

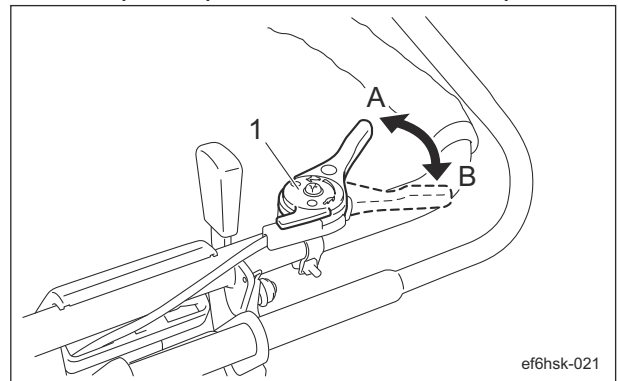

Throttle Lever\_001

1	Throttle lever
A	High speed
B	Low speed

# Description of Functions

## Brake Lever

### ⚠ Caution

Avoid quick operation.  
Carefully and slowly operate the machine.

The brake lever is located in the handle.  
Grip the brake lever to activate braking and the travel of the machine is stopped.  
Grip the lock lever while gripping the brake lever to lock the brake lever with braking applied.  
Grip the locked brake lever to release locking.  
Note:

Lock the brake lever to apply Parking Brake.

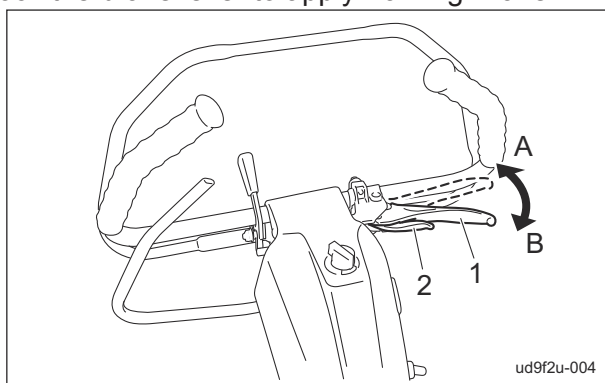

Brake Lever\_001

1	Brake lever
2	Lock lever
A	Lock
B	Unlock

## Clutch Lock Lever

The clutch lock lever is located in the handle.

### Important

While the main clutch is in the "OFF" position, the safety lock is activated.

Grip the main clutch lever while tilting the clutch lock lever to "Unlock" side to unlock the safety lock.

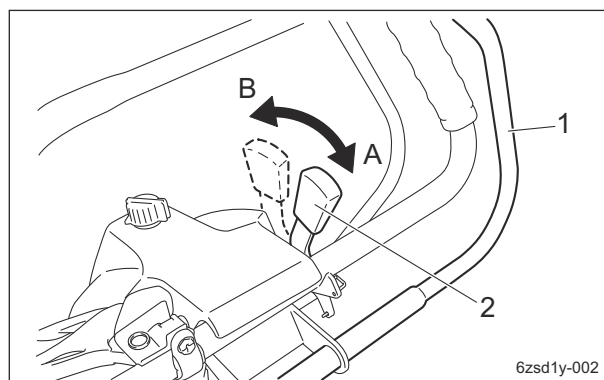

Clutch Lock Lever\_001

1	Main clutch lever
2	Clutch lock lever
A	Lock
B	Unlock

## Main Clutch Lever

### ⚠ Caution

Avoid quick operation.  
Carefully and slowly operate the machine.

### Important

The main clutch is not activated unless the safety lock released.

The main clutch lever is located in the handle.  
Unlock the safety lock and then grip the main clutch lever to traveling forward with rotating the reel cutter.  
Release the main clutch lever from the hands to stop the machine traveling and the reel cutter rotating.

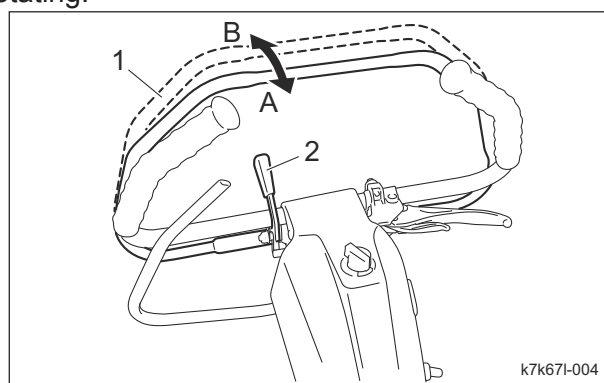

Main Clutch Lever\_001

1	Main clutch lever
2	Clutch lock lever
A	ON
B	OFF

# Description of Functions

## Drum Clutch Lever

**Caution**

Operate and set the lever to the proper position in accordance with the purpose when the main clutch lever set to the OFF position.

The drum clutch lever is located at the rear of the right frame side.  
 Set the lever to ON to activate the drum and the traveling wheels.  
 Set the lever to OFF for neutral.

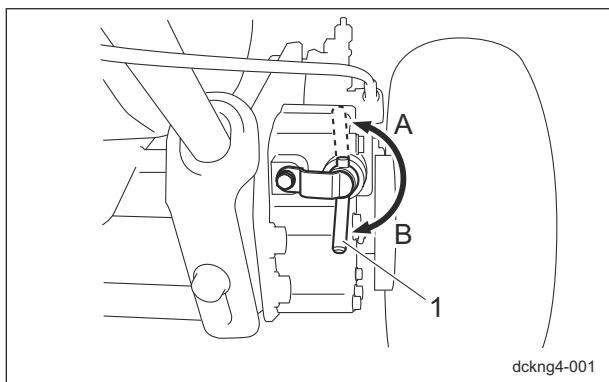

Drum Clutch Lever\_001

1	Drum clutch lever
A	ON
B	OFF

**Note:**  
 The machine can be moved easily with the lever OFF when the engine stopped.

## Unit Clutch Lever

**Caution**

Operate and set the lever to the proper position in accordance with the purpose when the main clutch lever set to the OFF position.

The unit clutch lever is located above the left frame.  
 Set the lever to the ON position and the power is transmitted from the transmission case to the unit.  
 Set the lever to the OFF position and the power from the transmission case to the unit is cut off.

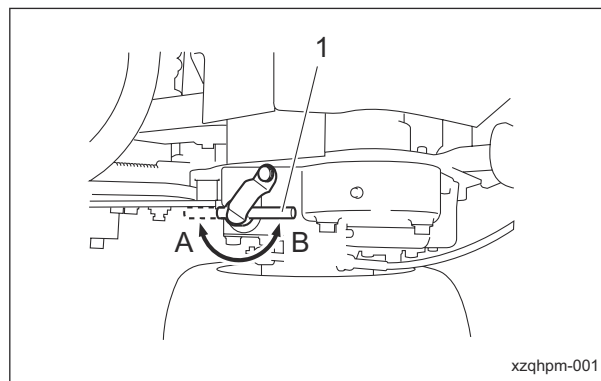

Unit Clutch Lever\_001

1	Unit clutch lever
A	ON
B	OFF

**Note:**  
 Set the lever to the OFF position when traveling.

## FOC (High/Low Clip) Selector Lever

**Caution**

Operate and set the lever to the proper position in accordance with the purpose when the main clutch lever set to the OFF position.

The FOC (High/Low Clip) selector lever is in the right side of the unit.  
 There are three changeover positions.  
 When the lever is shifted to "High clip", the reel cutter (cutting cylinder) rotates faster, and the clip pitch (cutting interval) becomes shorter. This is suitable for the work in good turf condition.  
 When the lever is shifted to "Low clip", the reel cutter (cutting cylinder) rotates slower compared to "High clip" and the clip pitch becomes longer. This is suitable for the work when the turf condition is not so good.  
 When the lever is shifted to "Stop", the drive transmission for the reel rotation gear is disengaged.

# Description of Functions

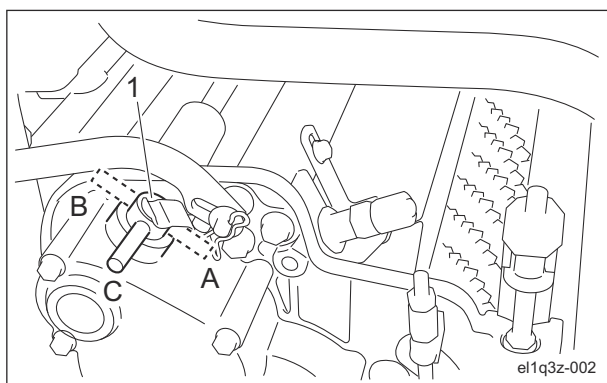

FOC (High/Low Clip) Selector Lever\_001

1	FOC (High/Low clip) Selector Lever
A	Low clip
B	High clip
C	Stop

## Engine Clutch Cover

The engine clutch cover is on the left side of the engine, covering the engine clutch. The engine clutch cover can be opened and closed with the fastening bolt taken off and put on.

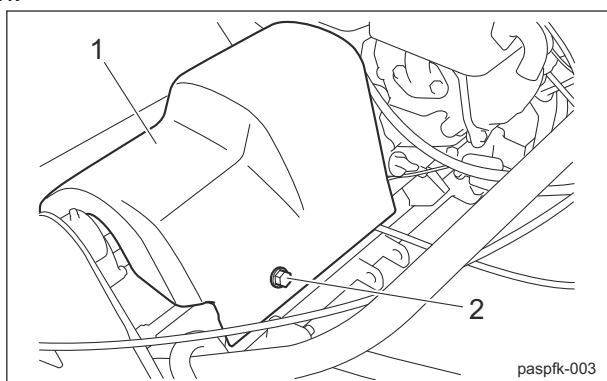

Engine Clutch Cover\_001

1	Engine Clutch Cover
2	Fastening bolt

## Groomer Clutch Lever

**Note:**  
Depending on the specifications, this function may not be available.

**⚠ Caution**

Operate and set the lever to the proper position in accordance with the purpose when the main clutch lever set to the OFF position.

The groomer clutch lever is in the left side of the unit.

There are three changeover positions.

When the lever is in the "Normal rotation" position, the groomer rotates in the same direction as the blade reel cylinder.

When the lever is in the "Reverse rotation" position, the groomer rotates in the opposite direction of the blade reel cylinder.

When the lever is in the "Rotation stop" position, the groomer does not rotate.

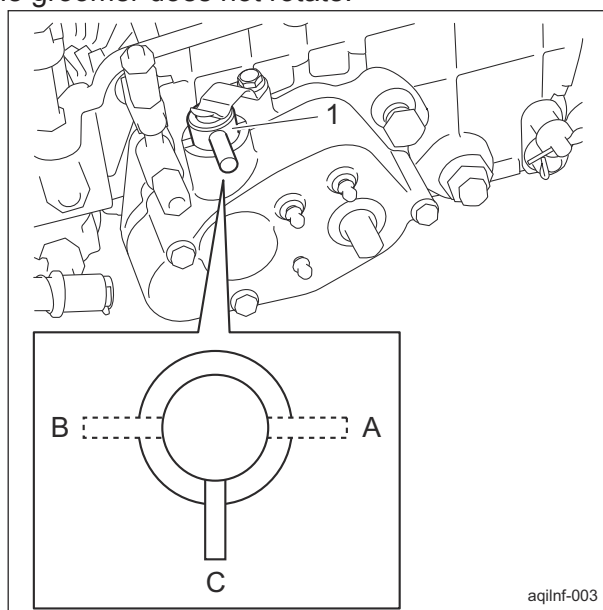

Groomer Clutch Lever\_001

1	Groomer clutch lever
A	Normal rotation
B	Reverse rotation
C	Rotation stop

# Description of Functions

## Instruments

### Hour Meter

The hour meter indicates the accumulated operation time of the engine.  
 (#10470 - 11283)

**Important**

The battery of this hour meter can not be replaced.  
 If the battery power is burned out, replace the hour meter with a new one.

The accumulated time can not be manually reset.  
 When the accumulated time exceeds 99999 hours, the display automatically shows zero for restart.

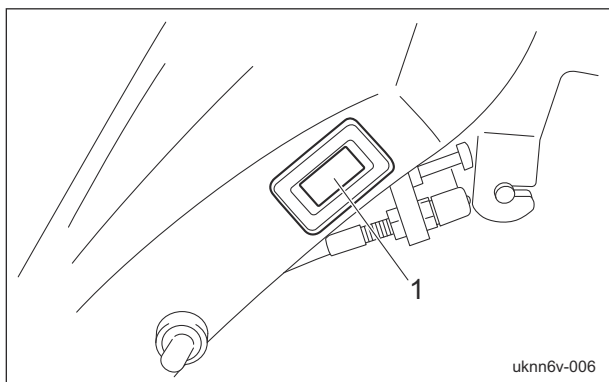

Hour Meter\_001

1	Hour meter
---	------------

(#11284-)

This hour meter features the following functions.

1. Clock  
The clock is displayed in a 24-hour clock.
2. RPM  
The RPM during the engine operation is displayed.
3. Maximum RPM  
The maximum RPM recorded during the last operating period can be checked.
4. Warning reminder  
The meter will blink when the RPM during the engine operation exceeds the set value.
5. Total hours of operation  
Total hours of operation is displayed. Total hours of operation can not be reset.  
When the accumulated time exceeds 99999 hours, the display automatically shows zero for restart.

6. Hour meter initial time setting  
Initial time setting can be set when the battery or the hour meter is replaced.
7. Maintenance reminder  
The alert starts two hours before the set maintenance interval time.
8. Maintenance timer  
Maintenance timer can be reset, and the hours of engine operation since it was reset can be checked.
9. RPM refresh rate  
The measurement interval for the engine RPM can be set.
10. The times of engine starts  
The total number of times of engine starts can be checked.
11. Alert for replacing battery  
Replace the battery when the battery icon starts to blink.  
When the battery is replaced, the accumulated time will be automatically reset to zero.

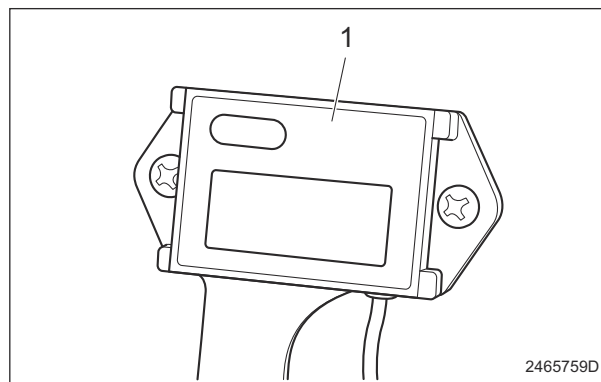

Hour Meter\_002

1	Hour meter
---	------------

Follow the steps below to replace the battery.

**Important**

When you set the new battery, make sure it fits properly under the click of the hour meter. If the battery is not set correctly, the screen of the hour meter will not be displayed.

[1] Open the back cover with a coin.

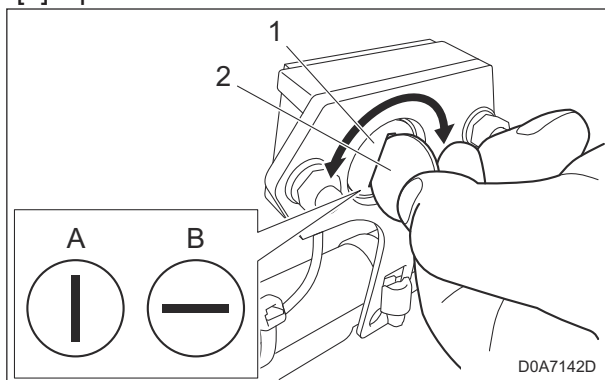

Hour Meter\_003

1	Back cover
2	Coin
A	Open
B	Close

[2] Replace the old battery with a new one.

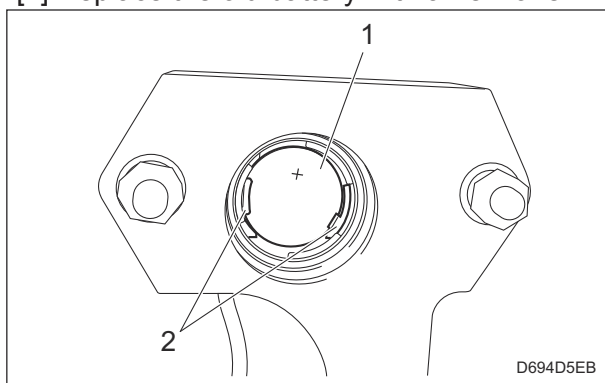

Hour Meter\_004

1	Battery
2	Click

[3] Close the back cover and lock it with a coin.

# Description of Functions

---

## **Operations before Service ..... Page 5-2**

Procedure to Open/Close Engine  
Clutch Cover ..... Page 5-2

## **Preparation for Use ..... Page 5-2**

Installation of The Handle ..... Page 5-2  
Connection of Engine Switch Cord ..... Page 5-2  
Installation of The Stand ..... Page 5-3  
Confirmation of The Operation ..... Page 5-3

## **Inspection before Use ..... Page 5-3**

Engine ..... Page 5-3  
Driving Section ..... Page 5-6  
Cutting Section ..... Page 5-6

## **Start/Stop of Engine ..... Page 5-8**

Procedure to Start Engine ..... Page 5-8  
Procedure to Stop Engine ..... Page 5-9

## **Parking and Stopping ..... Page 5-10**

Procedure to Leave The Machine ..... Page 5-10

## **Move ..... Page 5-10**

Traveling Procedure ..... Page 5-10

## **Cutting Work ..... Page 5-11**

Cutting Procedure ..... Page 5-11  
Procedure to Remove/Install  
Traveling Tires ..... Page 5-11  
Procedure to Remove/Install Grass  
Catcher ..... Page 5-12

## **Transporting ..... Page 5-13**

Transporting Procedure ..... Page 5-13

## **Cleaning after Use ..... Page 5-13**

Engine ..... Page 5-13  
Cutting Section ..... Page 5-13

## **Storage ..... Page 5-13**

Short-Term Storage ..... Page 5-13

# Handling Instructions

## Operations before Service

The following sections describe the preparatory works required before performing the services including inspection, adjustment, cleaning, maintenance and repair.

### Procedure to Open/Close Engine Clutch Cover

1. Procedure to open the engine clutch cover:

- [1] Remove the fastening bolt.
- [2] Open the engine clutch cover.

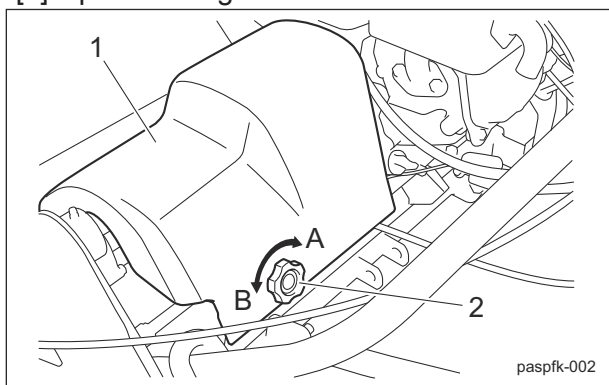

Procedure to Open/Close Engine Clutch Cover\_001

1	Engine clutch cover
2	Fastening bolt
A	Tight
B	Loose

2. Procedure to close the engine clutch cover:

- [1] Close the engine clutch cover.
- [2] Install the fastening bolt.

## Preparation for Use

### Installation of The Handle

1. Put the handle pin on the left frame into the hole at the left-side lower edge of the handle.
2. While pressing the right-side lower edge of the handle inward, put the handle pin of the right frame into the hole.

3. Secure the lower edges (slotted section of the handle adjusters) of the right and left sides of the handle to the rear frame stay from the back with the bolts, conical spring washers, and washers.

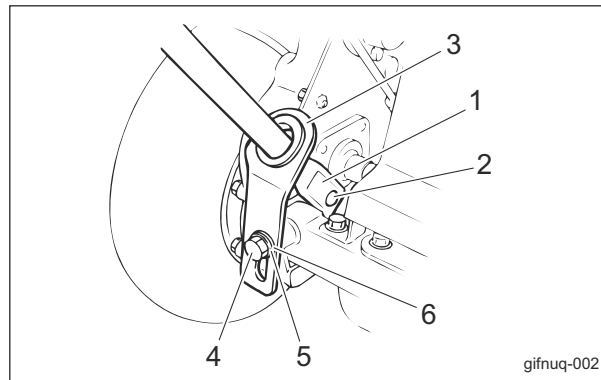

Installation of The Handle\_001

1	Lower edge of handle
2	Handle pin
3	Handle adjuster
4	Bolt
5	Conical spring washer
6	Washer

### Connection of Engine Switch Cord

#### Important

When the connection of the engine switch cord is incomplete, the engine will not stop even if the engine switch is operated. Check that the cord is correctly connected.

When assembling the handle, check the connection of the engine switch cord. There are two connections - plug and crimp terminal.

1. The plug is connected to the plug connected to the engine.
2. The crimp terminal is secured to the engine crankcase with a hexagon bolt.

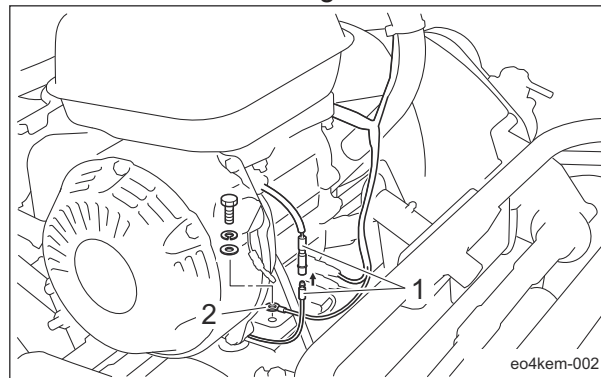

Connection of Engine Switch Cord\_001

# Handling Instructions

1	Plug
2	Crimp terminal

## Installation of The Stand

1. With the inside projection side set to the right, temporarily secure the left side of the stand to the frame with the bolt, washer (inside), and nut (outside).
2. Put the spring on the projection of the frame and the projection at the right edge of the stand.

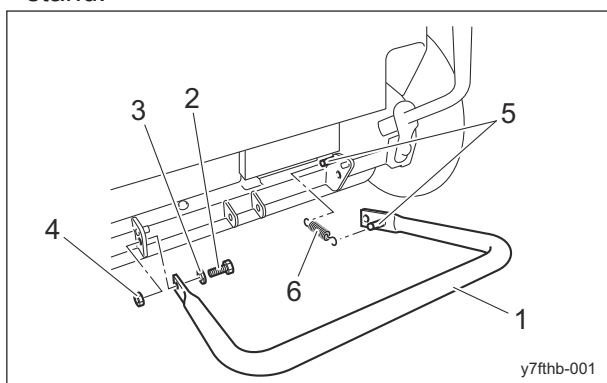

Installation of The Stand\_001

1	Stand
2	Bolt
3	Washer
4	Nut
5	Projection
6	Spring

3. While pulling the right side of the stand backward, make alignment with the hole in the frame, and secure the stand with the bolt, washer (inside), and nut (outside).
4. Tighten the bolt, washer, and nut at the left side of the stand that were temporarily secured.

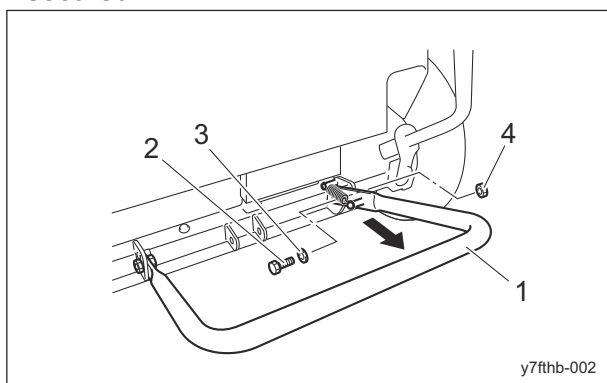

Installation of The Stand\_002

1	Stand
2	Bolt
3	Washer
4	Nut

## Confirmation of The Operation

1. Check that the brake operates completely.
2. Check that the engine clutch operates completely.
3. If necessary, make adjustment.

## Inspection before Use

The purpose of the machine inspection is to:

- Prevent accidents
- Prevent damage to the machine
- Maintain machine performance

Detecting machine malfunctions early helps prevent unexpected problems from occurring. If you detect any abnormalities with the machine, immediately perform maintenance or repairs.

## Engine

### Inspection of Engine Oil

#### Important

When installing the oil level gauge, tighten it securely.

Check the contamination of oil and engine oil level to inspect the engine oil. Inspect the engine oil level 10 to 20 minutes after stopping the engine.

1. Place the machine so that the engine is level.
2. Stop the engine.
3. Pull out the oil level gauge.

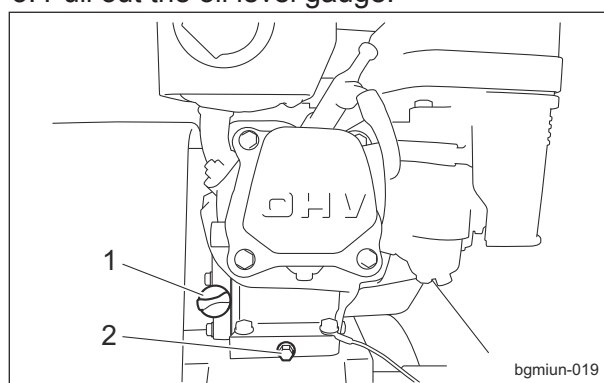

Inspection of Engine Oil\_001

# Handling Instructions

1	Oil level gauge (Oil filler port)
2	Drain plug

- Wipe the oil off the oil level gauge cleanly with papers or cloths.
- After wiping the oil off the oil level gauge, check the contamination.
- Return the oil level gauge to its original position, and pull out again without tightening it.
- Check the engine oil level.  
The appropriate engine oil level should be between the upper and lower limit lines on the gauge.

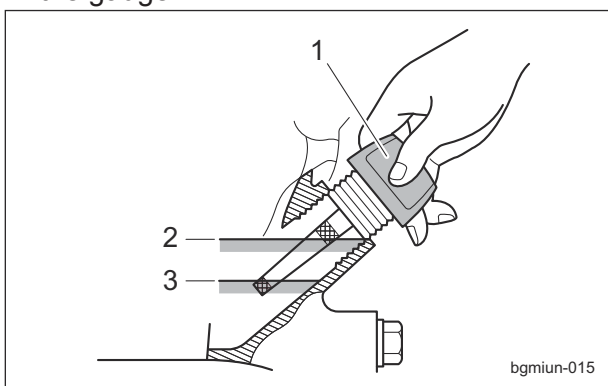

Inspection of Engine Oil\_002

1	Oil level gauge
2	Upper limit
3	Lower limit

- Return the oil level gauge to its original position, tighten it securely.

## Inspection of Fuel Quantity

Level the machine and then remove the tank cap to inspect fuel quantity from the fill port.

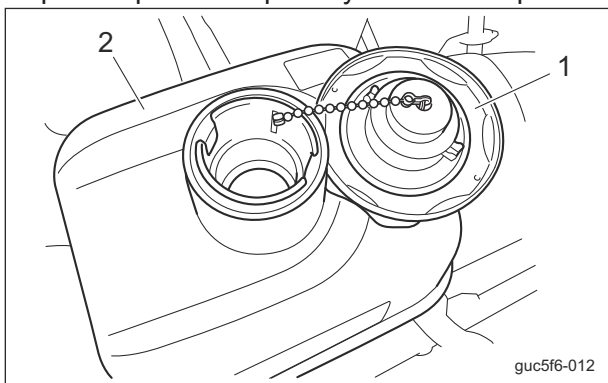

Inspection of Fuel Quantity\_001

1	Tank cap
2	Fuel tank

## Inspection of Fuel Strainer

- Make sure that there is no fuel leakage.
- Make sure that the fuel strainer is not damaged or dirty.

## Supply of Fuel

### ⚠ Caution

Do not supply fuel above FULL level of the fuel gauge.  
If you supply too much fuel, it might overflow from the fuel cap when you travel or work on a slope.

### ⚠ Caution

Keep fire away while refueling.  
Do not smoke while refueling.

### ⚠ Caution

Supply fuel after the engine is stopped and has well cooled down.

### ⚠ Caution

Pay attention not to touch hot parts.

Inspect the fuel quantity and put fuel (gasoline) if insufficient.  
The fuel tank capacity is approximately 2.0 dm<sup>3</sup> (2.0 L).

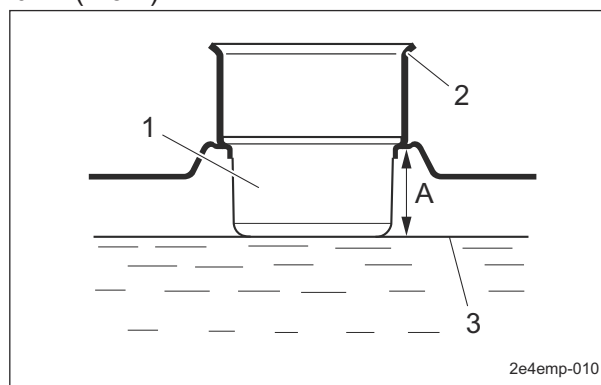

Supply of Fuel\_001

1	Fuel strainer
2	Filling opening
3	Maximum limit of fueling
A	2.5 cm (0.98 in)

# Handling Instructions

## Inspection of Liquid Leakage

### Important

After approximately 50 hours of operation, some tightened portions may be loosened and liquid such as oil may leak. Be sure to retighten the parts.

### Important

If liquid leakage found, repair it before operation. Ignoring leakage will cause further trouble.

1. Check the bottom of the machine for leakage of liquid such as oil, water, etc.
2. Locate the leakage and identify the type of liquid.

## Inspection of Air Cleaner

The air cleaner is a component that removes dirt from the intake air to prevent wear of the cylinder liners and piston rings so that the engine will always operate smoothly. A contaminated air cleaner element may cause malfunction of the engine.

1. Make sure that there is no damage to the air cleaner.
2. Make sure that the air cleaner element is not contaminated.

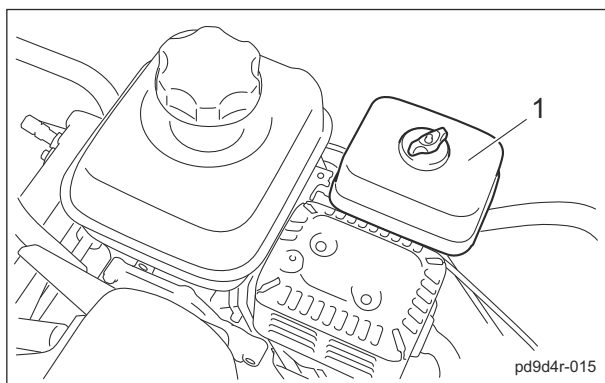

Inspection of Air Cleaner\_001

1	Air cleaner
---	-------------

## Inspection of Bolts and Nuts

### Important

The bolts and nuts may be loosened at the earlier stage of the use. Be sure to retighten or replace before operating the machine whenever there is any abnormality.

1. Check the bolts and nuts for looseness and coming off.
2. Check the bolts and nuts for cracks and damages.
3. Check the bolts and nuts for rust.
4. Check around the bolts and nuts for traces of rust fluid.
5. Check for unequal bolt length.
6. Check the bolts and nuts for stripped threads and abrasion.

## Inspection of Engine-Associated Parts

### Caution

Perform operations after the muffler, engine and other parts have sufficiently cooled. Otherwise, you may get burned.

1. Check for damages and dirt.
2. Check the mount for looseness and cracks.
3. Check for liquid leakage.
4. Check on and around the muffler for grass clippings and flammable materials.

# Handling Instructions

## Driving Section

### Inspection of Tires

1. Make sure that there are no cracks, damage or abnormal wear.
2. Check the pneumatic pressure of the tires.

	Tire size	Pneumatic pressure	
Tire for traveling	4.10/3.50-6	120 kPa (1.2 kgf/cm <sup>2</sup> )	17 psi

### Inspection of Clutch Lever

1. Make sure that there is no play in the lever.
2. Make sure that the lever moves smoothly.
3. Make sure that there is no abnormal sound when the lever is moved.

### Inspection of Clutch Lock Lever

1. Make sure that there is no play in the clutch lock lever.
2. Make sure that the clutch lock lever moves smoothly.
3. Make sure that the main clutch lever is not in the "ON" position when the clutch lock lever is tilted to the "LOCK" side.
4. Make sure that you can fully grip the main clutch lever when the clutch lock lever is tilted to the "UNLOCK" side.

### Inspection of Covers

#### Warning

If you have removed the cover during inspection, make sure that you replace it in the original position securely. If the cover remains removed, the operator or the mechanic may come in contact with the rotating objects or belt, or foreign objects may fly off, possibly resulting in injuries.

1. Make sure that there is no wear or deterioration of covers.
2. Make sure that there is no damage to covers.
3. Make sure that there is no interference with moving parts due to deformation of covers.
4. Make sure that covers are installed in their appropriate positions.

### Inspection of Brake

1. Grip the brake lever and make sure that the brake can operate completely.
2. Operate the lock lever and make sure that it can lock the brake lever.
3. Make sure that the brake is not applied even slightly after releasing the lock on the brake lever.

### Inspection of Wire

1. Make sure that the wire is not cracked or damaged.
2. Make sure that the wire is not worn.
3. Make sure that the wire is not crushed.
4. Make sure that the wire is not bent.
5. Make sure that the wire is not corroded or rusted.

## Cutting Section

### Cleaning of Cutting Section

#### Important

While cleaning, do not allow water on the sealed parts of the reel shaft. (Avoid high-pressure water cleaning.) Otherwise, it may cause damage to the machine.

Be sure to clean the cutting section after use.

1. Stop the engine, and then remove the key.
2. Carefully clean the front and back of the cutting section with water or compressed air.
3. Remove any grass wrapped around the reel cutter (cutting cylinder).

### Inspection of Reel Cutter (Cutting Cylinder) and Bed Knife (Bottom Blade)

#### Caution

Wear gloves when touching edged tools to avoid cutting your hands.

1. Check to see whether or not the edge of the reel cutter (cutting cylinder) and the bed knife (bottom blade) are too blunt to cut.
2. Make sure that the reel cutter (cutting cylinder) and the bed knife (bottom blade) are not cracked.

# Handling Instructions

3. Check to see how much the reel cutter (cutting cylinder) and the bed knife (bottom blade) are worn.
4. Make sure that the reel cutter (cutting cylinder) and the bed knife (bottom blade) have not changed color due to heat from grinding.
5. Check to see whether or not the second edge face (relief) remains at the point of reel cutter (cutting cylinder).
6. Make sure that the welding between the reel cutter (cutting cylinder) and the disc has not come off.

## Inspection of Covers

### Warning

If you have removed the covers during inspection, be sure to securely install them in their original positions. If a cover remains removed, the operator or the mechanic may come into contact with rotating parts or belts and foreign objects may fly off, possibly resulting in injuries.

1. Make sure that there is no wear or deterioration of the reel cover and all other covers.
2. Make sure that there is no damage to the reel cover and all other covers.
3. Make sure that there is no interference with moving parts due to deformation of the reel cover and all other covers.
4. Make sure that the reel cover and all other covers are installed in their appropriate positions.

## Inspection of Rollers

1. Make sure that there is no abrasion nor adhesion of the roller.
2. Make sure that there is no wear of the roller shaft.
3. Make sure that there is no wear nor damage of the oil seal.
4. Make sure that there is no wear nor rust of the bearing.
5. Make sure that there is no play in the roller shaft.

## Inspection of Drum

1. Make sure that the drum is not cracked or damaged.

## Inspection before Use

2. Make sure that there is no abrasion or adhesion of the drum.
3. Make sure that there is no play in the fit of the drum and the bearing.

## Inspection of Groomer

### Note:

Depending on the specifications, this function may not be available.

### Caution

Wear gloves when touching edged tools to avoid cutting your hands.

1. Make sure that the vertical blades are not cracked.
2. Check how much the vertical blades are worn.
3. Make sure that the shaft is not worn nor bent.
4. Make sure that there is no wear nor rust of the bearing.
5. Make sure that there is no play in the groomer shaft.

## Inspection of Grass Catcher

1. Make sure that there is no wear or deterioration of the grass catcher.
2. Make sure that there is no damage to the grass catcher.
3. Make sure that there is no interference to moving parts due to deformation of the grass catcher.

# Handling Instructions

## Start/Stop of Engine

### Procedure to Start Engine

**⚠ Caution**

Before starting the engine, make sure that there are no other people or obstacles around the machine.

**⚠ Caution**

Make sure that the engine clutch cover is installed in the prescribed position.

1. Make sure that the engine switch is in the "OFF" position.

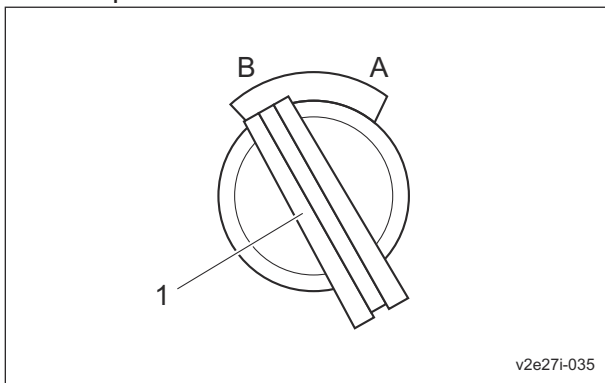

v2e27i-035

Procedure to Start Engine\_001

1	Engine switch
A	ON
B	OFF

2. Make sure that the brake is locked.

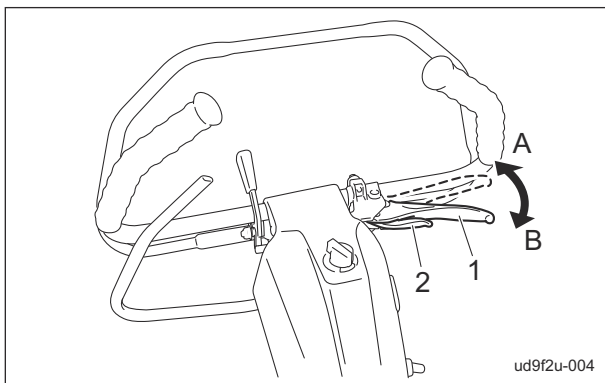

ud9f2u-004

Procedure to Start Engine\_002

1	Brake lever
2	Lock lever
A	Lock
B	Unlock

3. Don't grip the main clutch lever.

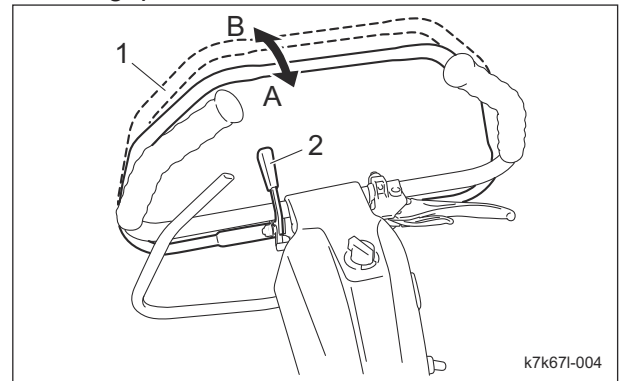

k7k67i-004

Procedure to Start Engine\_003

1	Main clutch lever
2	Clutch lock lever
A	ON
B	OFF

4. Set the fuel cock to the "Open" position.

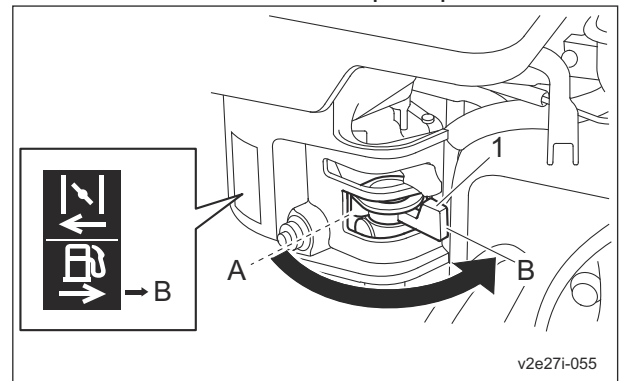

v2e27i-055

Procedure to Start Engine\_004

1	Fuel cock
A	Close
B	Open

5. Set the engine switch to the "ON" position.

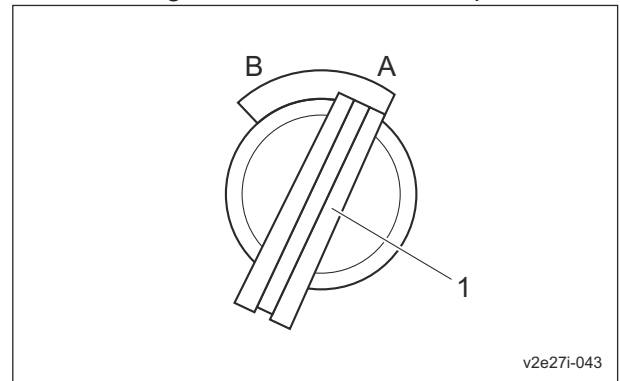

v2e27i-043

Procedure to Start Engine\_005

1	Engine switch
A	ON
B	OFF

# Handling Instructions

6. Set the choke lever to the "Close" position.

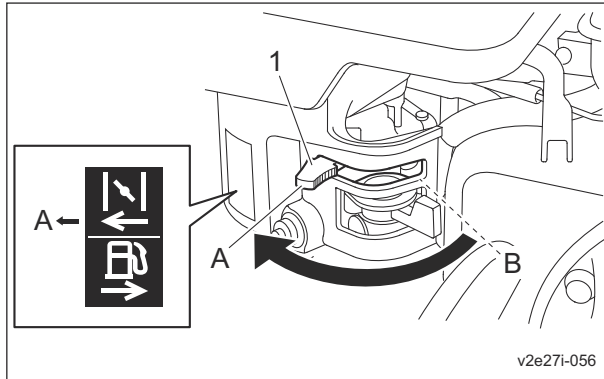

Procedure to Start Engine\_006

1	Choke lever
A	Close
B	Open

8. Set the choke lever to the "Open" position.

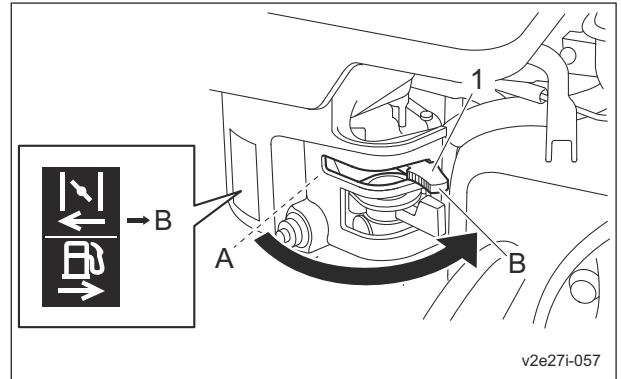

Procedure to Start Engine\_008

1	Choke lever
A	Close
B	Open

**Important**

Return the starter grip slowly to its original position after the engine starts. Do not let go of the pulled starter grip since it may cause damage to the machine.

7. Pull the starter grip swiftly, and the engine will start.

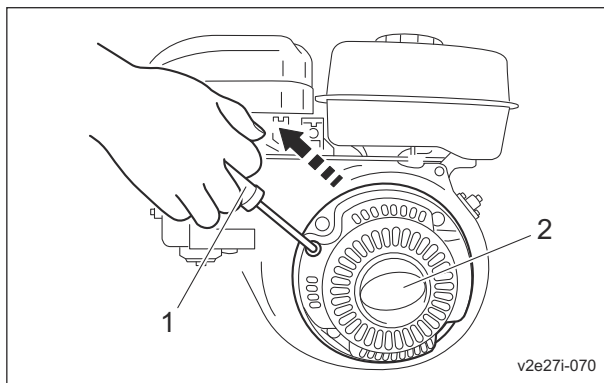

Procedure to Start Engine\_007

1	Starter grip
2	Recoil starter

## Procedure to Stop Engine

1. Don't grip the main clutch lever.

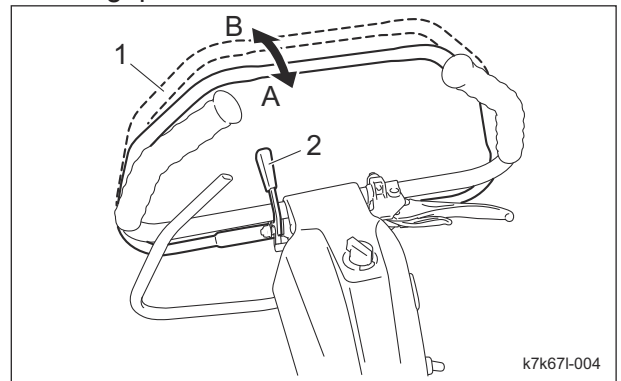

Procedure to Stop Engine\_001

1	Main clutch lever
2	Clutch lock lever
A	ON
B	OFF

2. Grip the lock lever while gripping the brake lever to lock the brake.

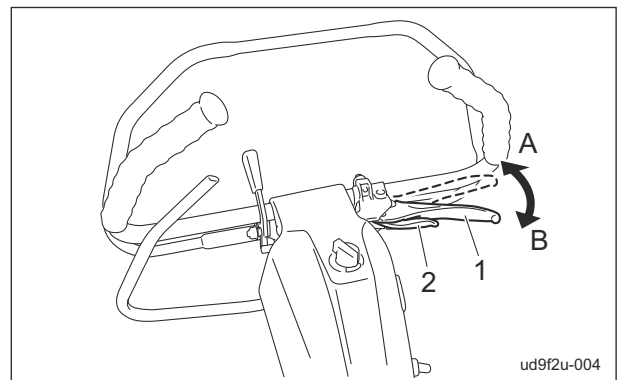

Procedure to Stop Engine\_002

# Handling Instructions

1	Brake lever
2	Lock lever
A	Lock
B	Unlock

3. Set the engine switch to the "OFF" position.

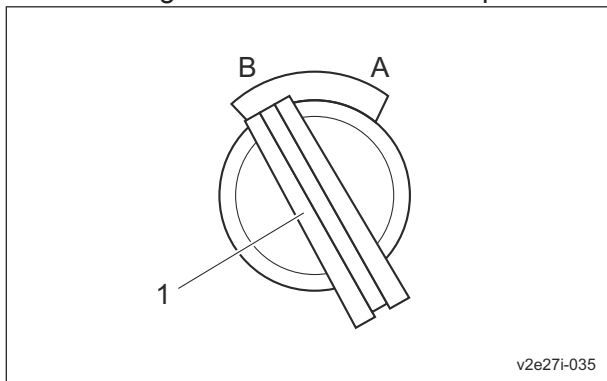

Procedure to Stop Engine\_003

1	Engine switch
A	ON
B	OFF

4. Make sure that the engine has stopped.

5. Set the fuel cock to the "Close" position.

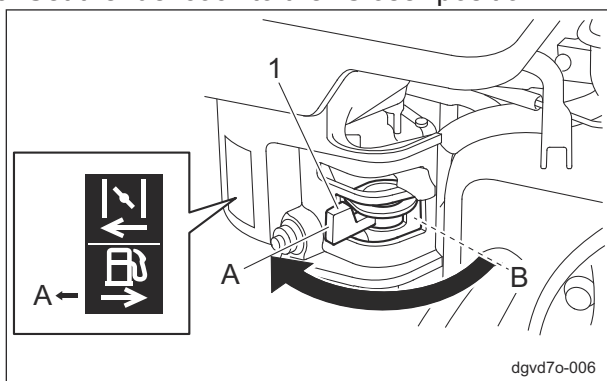

Procedure to Stop Engine\_004

1	Fuel cock
A	Close
B	Open

## ⚠ Caution

Check that the engine has stopped.

1. Stop the machine on a flat place.
2. Make sure that the brake lever is locked.
3. Stop the engine.
4. Set the fuel cock to the "Close" position.
5. Leave the machine.

## Move

### Traveling Procedure

## ⚠ Caution

Under any circumstances drive the machine at such a speed that you can stop it immediately for emergencies.

## ⚠ Caution

Do not start to move or stop the machine abruptly.

1. Install traveling tires.
2. Flip up the stand.
3. Set the drum clutch lever to "ON" position.
4. Set the unit clutch lever to "OFF" position.
5. Start the engine.
6. Release the brake.
7. Release the safety lock and grip the main clutch lever slowly.
8. The machine starts traveling.
9. Release the main clutch lever to stop the machine.

## Parking and Stopping

### Procedure to Leave The Machine

## ⚠ Caution

If the brakes are not sufficiently effective, use the wheel stoppers to secure the machine.

## ⚠ Caution

Do not park the machine on a slope.

# Handling Instructions

## Cutting Work

### Cutting Procedure

#### ⚠ Warning

Do not operate on a steep slope.

#### ⚠ Caution

Do not start to move or stop the machine abruptly.

#### ⚠ Caution

Be sure to operate at an appropriate speed for the mowing site.  
For mowing on an undulated surface, mow with lowered cutting speed.

#### Important

Be sure to attach the grass catcher.  
Discharge the clippings at the right time during operation.

1. Remove the traveling tires.
2. Flip up the stand.
3. Install the grass catcher.
4. Move the FOC (High/Low Clip) selector lever to the desired position.
5. Move the drum clutch lever to the "ON" position.
6. Move the groomer clutch lever to the desired position.
7. Move the Unit clutch lever to the "ON" position.
8. Start the engine.
9. Release the brake.
10. Release the safety lock and grip the main clutch lever slowly to start mowing.

Note:

Operate at about 3,000 rpm.

### Procedure to Remove/Install Traveling Tires

#### Important

Remove the traveling tires before cutting work.

Traveling tires are used to travel.

Removing Traveling Tires:

1. Stop the engine.
2. Flip down the stand.

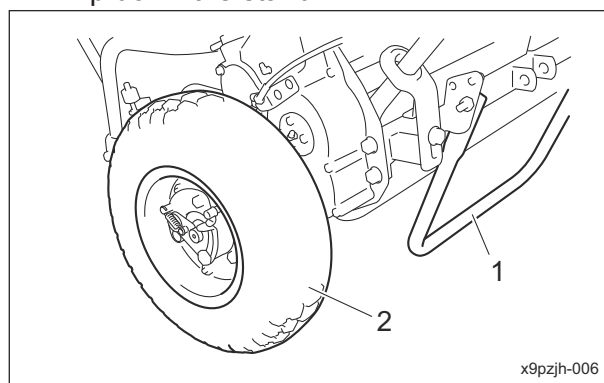

Procedure to Remove/Install Traveling Tires\_001

1	Stand
2	Traveling tire

3. While holding the lever of the wheel mount plate to the release position, pull the traveling tire toward you to remove it.

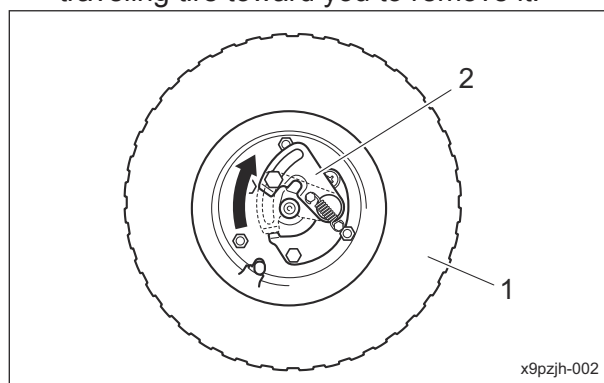

Procedure to Remove/Install Traveling Tires\_002

1	Traveling tire
2	Wheel mount plate

# Handling Instructions

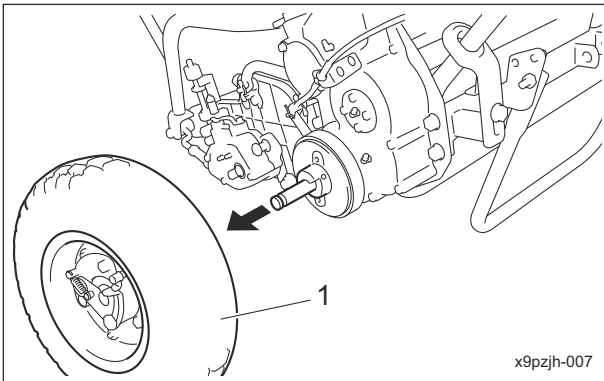

Procedure to Remove/Install Traveling Tires\_003

1	Traveling tire
---	----------------

4. Repeat the same process for removing the opposite traveling tire.

Installing Traveling Tires:

1. Stop the engine.

2. Flip down the stand.

**Important**

The drum shaft and the traveling tires have mating parts each other. Make sure of their shapes to install the traveling tires.

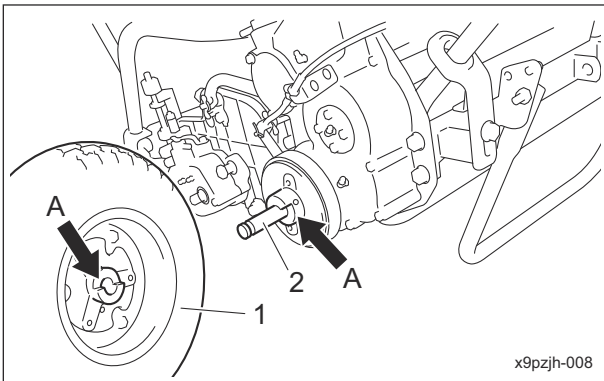

Procedure to Remove/Install Traveling Tires\_004

1	Traveling tire
2	Drum shaft
A	Mating parts

3. Install the traveling tire to the drum shaft.

**Important**

Make sure that the wheel mount plate is grooved on the drum shaft. Otherwise the tires will come off.

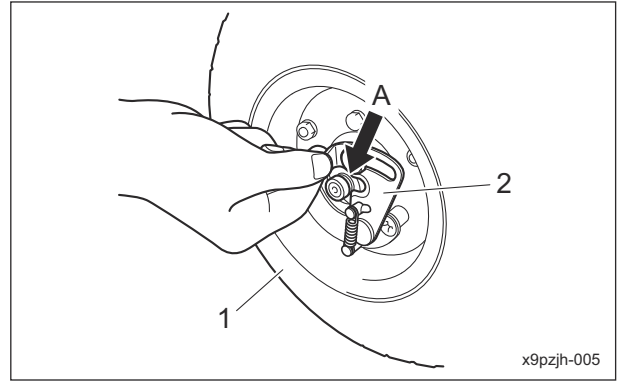

Procedure to Remove/Install Traveling Tires\_005

1	Traveling tire
2	Wheel mount plate
A	Groove

## Procedure to Remove/Install Grass Catcher

**Caution**

Stop the engine before removing/installing the grass catcher.

Removing Grass Catcher:

Lift up the grass catcher and remove it from the grass catcher fitting bars.

Installing Grass Catcher:

Insert the grass catcher fitting bars into the slots of the grass catcher.

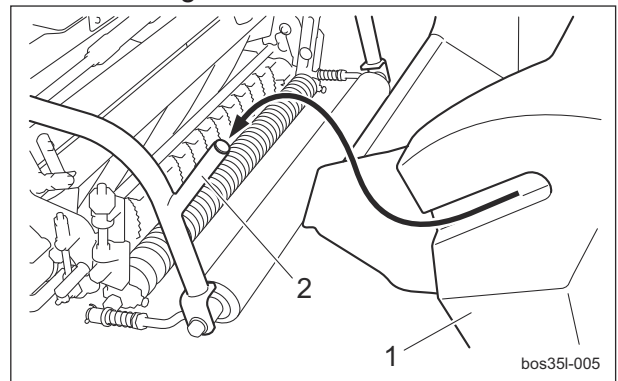

Procedure to Remove/Install Grass Catcher\_001

1	Grass catcher
2	Grass catcher fitting bar

# Handling Instructions

## Transporting

### Transporting Procedure

#### ⚠ Caution

When loading and unloading the machine, wear non-slip shoes and travel slowly.

#### Important

When securing the machine with a rope, do not tie the rope to the engine.

#### Important

When securing the machine with a rope, be careful not to bend any wires.

Be extremely careful when loading the machine into a truck or a trailer. Before loading or unloading, stop the truck or trailer on a level surface in a safe location, apply the parking brake, stop the engine, and then chock the wheels. Before loading into a truck or a trailer for transportation, apply the parking brake of the machine, stop its engine, and then secure the machine with rope or any other sufficiently strong restraining device. When using a loading ramp, select one of sufficient length, width and strength, and that will not allow the machine to slip off.

## Cleaning after Use

The purpose of the machine cleaning is to:

- Prevent accidents
- Prevent damage to the machine
- Maintain machine performance

Properly clean the machine to maintain its functionality and performance.

If you detect any abnormalities with the machine, immediately perform maintenance or repairs.

## Engine

### Cleaning of Engine-Associated Parts

#### ⚠ Caution

Perform operations after the muffler, engine and other parts have sufficiently cooled. Otherwise, you may get burned.

1. Clean clippings and remove dirt.
2. Blow compressed air to clean any grass or flammable materials that may be attached on or around the muffler.

## Cutting Section

### Cleaning of Cutting Section

#### Important

While cleaning, do not allow water on the sealed parts of the reel shaft. (Avoid high-pressure water cleaning.) Otherwise, it may cause damage to the machine.

- Be sure to clean the cutting section after use.
1. Stop the engine, and then remove the key.
  2. Carefully clean the front and back of the cutting section with water or compressed air.
  3. Remove any grass wrapped around the reel cutter (cutting cylinder).

## Storage

### Short-Term Storage

Short-term storage means that the machine is temporarily stored (within 1 month) without use.

Follow the instructions below for short-term storage of the machine.

1. Cleaning
  - Remove dirt, grass clippings, oil stains etc. completely from the main vehicle and engine.
2. Storage location
  - Cover the machine and store it in a dry place where it will not be exposed to rain.

# Handling Instructions

---

<b>Precautions for Maintenance .....</b>	<b>Page 6-2</b>
<b>Position of Mower during Maintenance .....</b>	<b>Page 6-2</b>
<b>Inspection and Cleaning .....</b>	<b>Page 6-3</b>
Engine .....	Page 6-3
Driving Section .....	Page 6-4
<b>Supplying Fluids .....</b>	<b>Page 6-5</b>
Engine .....	Page 6-5
<b>Greasing .....</b>	<b>Page 6-5</b>
About Greasing .....	Page 6-5
Greasing Points .....	Page 6-6
<b>Lubrication .....</b>	<b>Page 6-10</b>
About Lubrication .....	Page 6-10
Lubricating Points .....	Page 6-10
<b>Adjustment .....</b>	<b>Page 6-11</b>
Driving Section .....	Page 6-11
Cutting Section .....	Page 6-11
<b>Replacement .....</b>	<b>Page 6-23</b>
Engine .....	Page 6-23
Cutting Section .....	Page 6-24
<b>Storage .....</b>	<b>Page 6-32</b>
Long-Term Storage .....	Page 6-32

# Maintenance

## Precautions for Maintenance

### Warning

The chapter "Maintenance" in this manual describes practical measures which should be performed by a mechanic with expertise. The owner should instruct the mechanic with expertise to perform maintenance service for this machine.

### Caution

First, learn well the operations you plan to perform.

### Important

Use tools appropriate for each operation.

### Important

Use Barons genuine parts for replacement and accessories. Our product warranty may be void if you use non-genuine parts for replacement or accessories.

## Position of Mower during Maintenance

### Important

If the mower handle is left leaned on the ground for a long time during maintenance engine oil will enter the engine combustion chamber and cause the engine to run improperly.

Be careful not to keep this position long and ensure sufficient time for any oil to drain back by returning to upright position for ten minutes before starting.

### Important

An attitude of the machine tilting toward the handle side at a large angle may cause the engine malfunction.

### Note:

The attitude of the machine tilting toward the handle side at a large angle is a state where the engine tilts more than 30 degrees from the upright position.

- For maintenance of the machine fitted with the traveling wheels:  
Use the maintenance stand to prevent from the engine malfunction.

### Caution

Pay attention to the machine standing up with the maintenance stand lifted up when large power is added to the mower unit of the machine tilting toward the handle side.

- Park the machine on a level place.
- Tilt it slowly toward the handle side and pass the main clutch lever through the pipe of the maintenance stand.
- Set the handle so that the maintenance stand can stand upright.

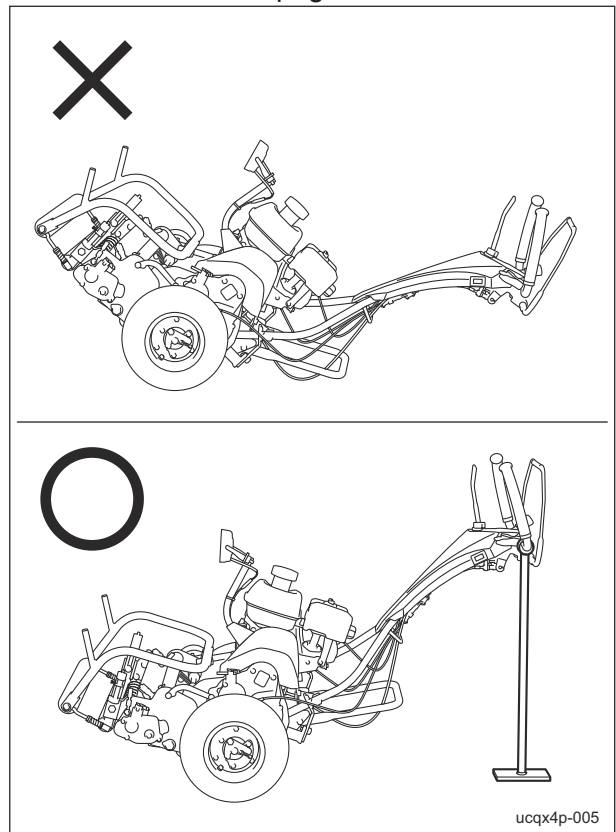

Position of Mower during Maintenance\_001

1 Maintenance stand

- For maintenance of the machine without the traveling wheels:

### ⚠ Caution

The engine malfunction does not occur even when the machine tilting toward the handle side with the stand touching the ground. Pay attention to the machine standing up depending on the unbalanced state owing to the adjusted position of the handle height.

1. Park the machine on a level place.
2. Tilt it slowly toward the handle side and set it so that the stand can touch the ground.

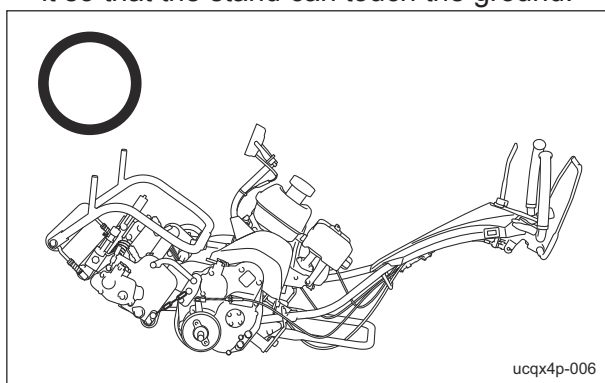

Position of Mower during Maintenance\_002

## Inspection and Cleaning

Inspect and clean the machine with the goals of the followings.

- Accident prevention
- Failure prevention
- Performance retention

Make efforts for early detection of the machine failure and prevention of the sudden occurrence of trouble.

Perform maintenance and repair works immediately if any abnormality is found in the machine.

### Engine

#### Cleaning of Fuel Strainer

If dust or dirt accumulates in the fuel strainer, the fuel flow will become insufficient. Periodically clean it.

### Important

Clean the fuel strainer in a clean location, free of dust and dirt.

1. Close the fuel cock of the fuel strainer.
2. Remove the strainer cup.

3. Clean the filter and the inside of the strainer cup with a solvent, such as hardly flammable kerosene.
4. Dry with compressed air.

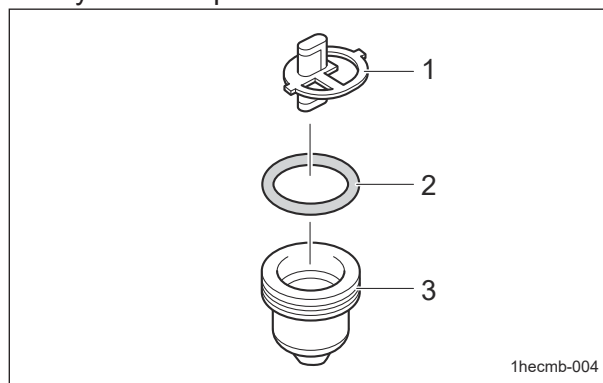

Cleaning of Fuel Strainer\_001

1	Filter
2	O ring
3	Strainer cup

### Important

During installation, prevent contamination with dirt or dust.

If the fuel is contaminated with dirt, dust, etc., the fuel flow will become insufficient.

5. Correctly install all parts in their original positions.
6. Fill up the fuel tank with fuel, and then open the fuel cock.
7. Make sure that there is no fuel leakage.

# Maintenance

## Cleaning of Air Cleaner Element

A contaminated air cleaner elements may cause malfunction of the engine.

To maximize the life of the engine, clean the air cleaner properly.

1. Remove the wing screw, and then remove the cover.
2. Remove the screw, and then remove the air cleaner elements.
3. Remove the urethane element from the paper element.

### Important

When cleaning the paper element, do not use petroleum solvents.

### Important

Replace the air cleaner elements when it gets damaged or dirty.

4. Clean the urethane element with a solvent, such as a hardly flammable kerosene, and then soak it in the engine oil and wring out.
5. Remove dirt and dust from the paper element with blowing air or patting.
6. Assemble the paper and urethane elements.
7. Attach the air cleaner elements with the screw.
8. Set the cover, and then secure it firmly with the wing screw.

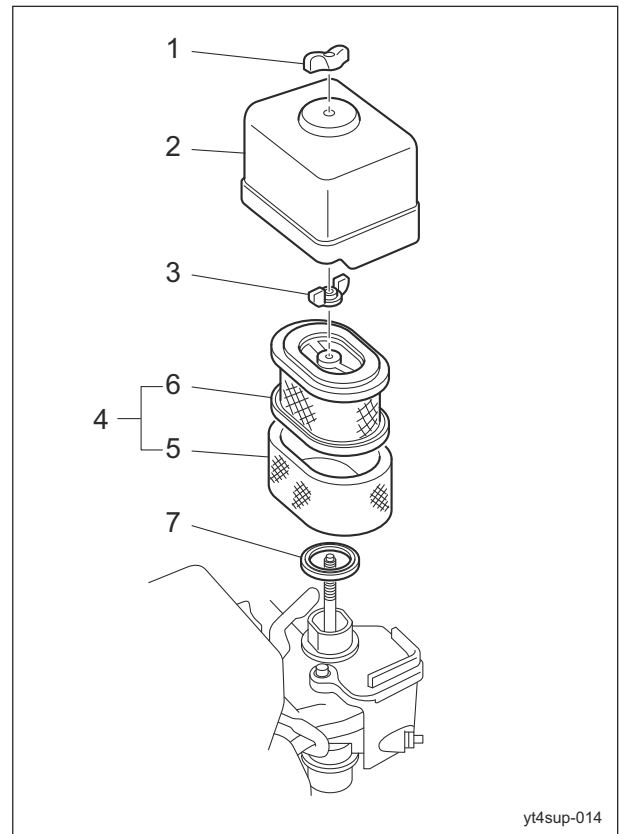

yt4sup-014

Cleaning of Air Cleaner Element\_001

1	Wing screw
2	Cover
3	Screw
4	Air cleaner element
5	Urethane element
6	Paper element
7	Gasket

## Driving Section

### Inspection of Electrical Wiring

#### Important

Electrical short circuit will cause fire, electrical leakage and malfunction of electrical equipments.

1. Make sure that there is no defacement in wires and terminals.
2. Make sure that there is no deterioration or damage in wires and terminals.
3. Make sure that there is no looseness in wiring connections.
4. Make sure that there is no poor terminal connection.

## Supplying Fluids

### Engine

#### Supply of Engine Oil

##### Important

Do not supply too much engine oil. Otherwise, the engine may be damaged.

##### Important

Do not mix different types of engine oil.

##### Important

Be sure to use engine oil that is classified as API Service Grade SE or higher, with an SAE Viscosity that is appropriate for the operating environment (ambient temperature).

##### Important

When installing the oil level gauge, tighten it securely.

If the engine oil level is lower than the lower limit line on the oil level gauge, supply engine oil.

Supply engine oil through the oil filler port.

1. Place the machine so that the engine is level.
2. Stop the engine.
3. Remove the oil level gauge.

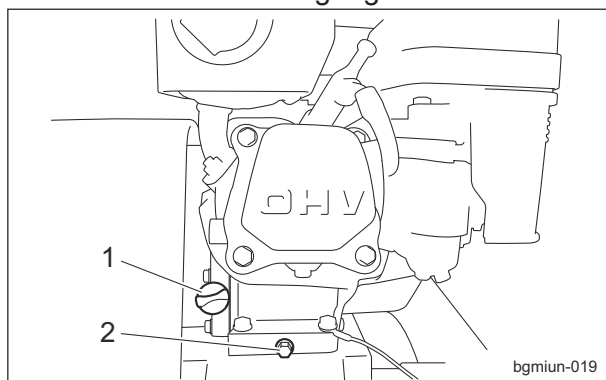

Supply of Engine Oil\_001

1	Oil level gauge (Oil filler port)
2	Drain plug

4. Supply new engine oil through the oil filler port.

Supply oil until it reaches a level in the upper limit line on the oil level gauge.

5. Check the engine oil level without tightening the oil level gauge into the oil filler port.

6. Tighten the oil level gauge firmly.

## Greasing

### About Greasing

Since there may be adhesion or damage due to lack of grease on moving parts, they must be greased.

Add urea-based No. 2 grease in accordance with the Maintenance Schedule.

Other locations where the specified grease or lubricant is used are indicated in "Greasing Points".

Add grease using the specified grease or lubricant.

# Maintenance

## Greasing Points

Grease nipples are installed in the following locations.  
 Add grease to A every 10 hours, and B every 50 hours.  
 If specified locations and periods are additionally described below, follow the instructions.

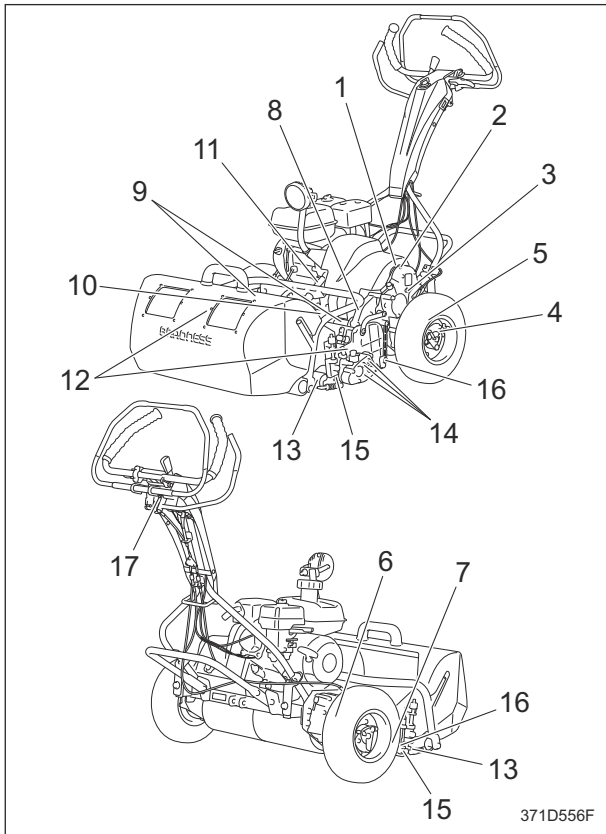

Greasing Points\_001

	Location	No. of greasing points	Greasing period	
1	Upper side of left framecover	1	-	B
2	Mower #1 shaft	1	-	B
3	Left frame #2 shaft	1	A	-
4	Left frame #4 shaft	1	A	-
5	Differential gear	1	A	-
6	Right frame #2 shaft	1	A	-
7	Right gear case	1	A	-
8	Transmission gear case	1	A	-
9	Transmission shaft	2	A	B
10	Transmission shaft spline	1	-	B
11	Arm mounting hitch fulcrum	1	-	B
12	Reel housing	2	A	-
13	Front roller	2	-	B
14	Groomer gear case	3	A	-
15	Groomer shaft	2	-	B
16	Cam bush	2	Refer to "Maintenance Schedule."	
17	Handle	1	-	B

### 1. Upper side of left frame cover

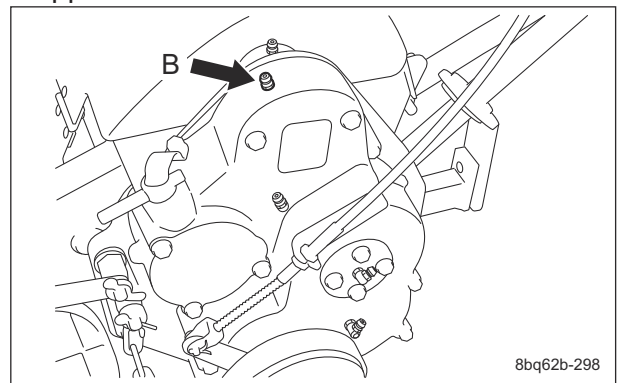

Greasing Points\_002

### 2. Mower #1 shaft

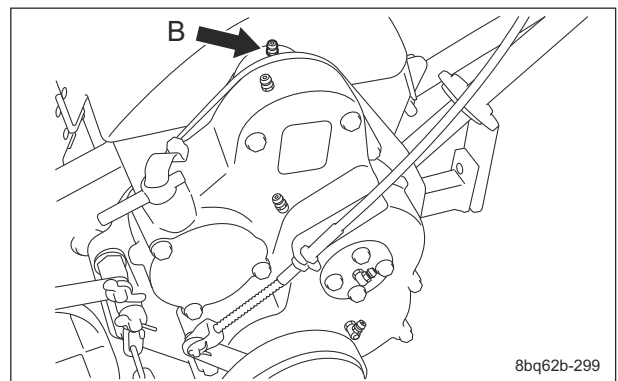

Greasing Points\_003

### 3. Left frame #2 shaft

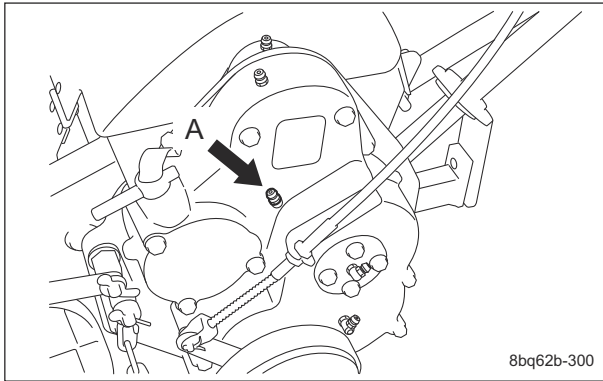

Greasing Points\_004

### 7. Right gear case

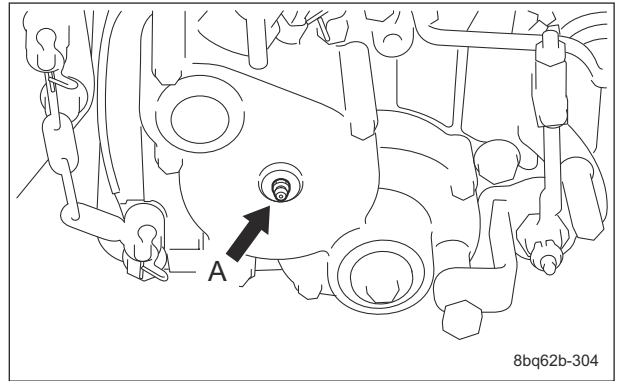

Greasing Points\_008

### 4. Left frame #4 shaft

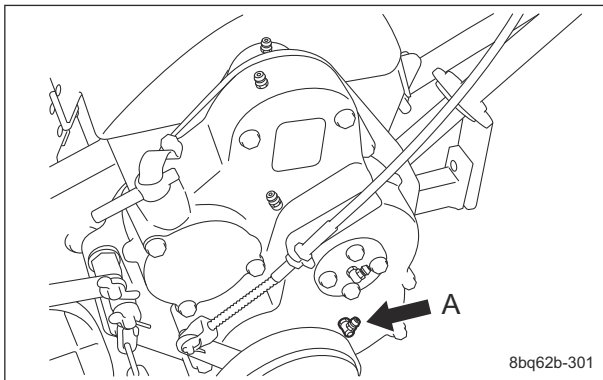

Greasing Points\_005

### 8. Transmission gear case

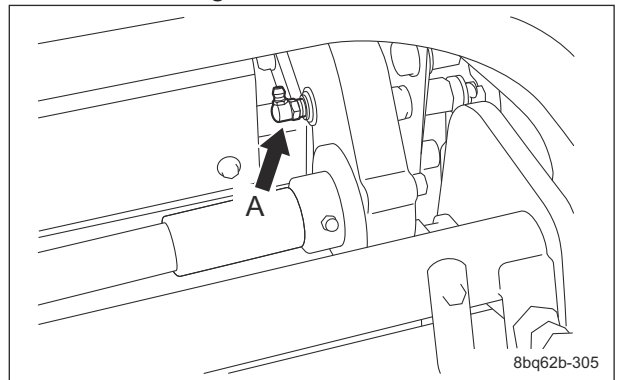

Greasing Points\_009

### 5. Differential gear

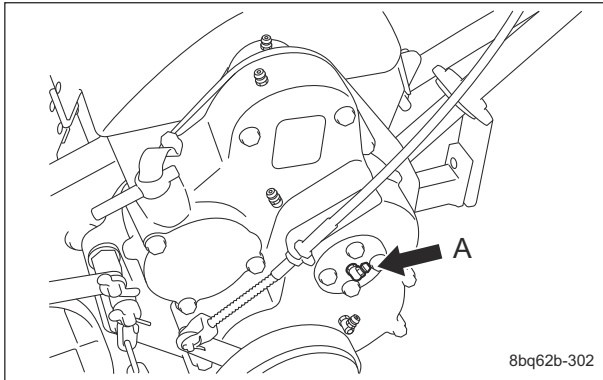

Greasing Points\_006

### 9. Transmission shaft

There are one location each on the right and left.  
Left side

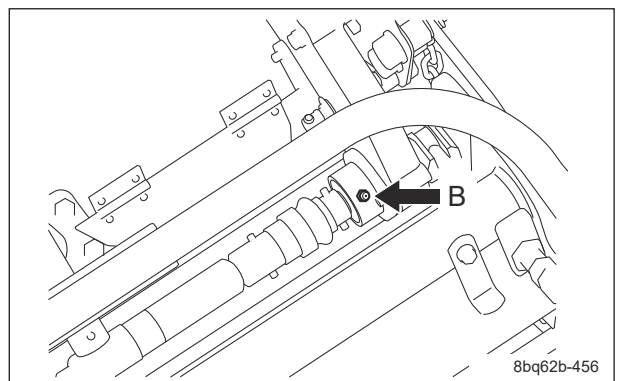

Greasing Points\_010

### 6. Right frame #2 shaft

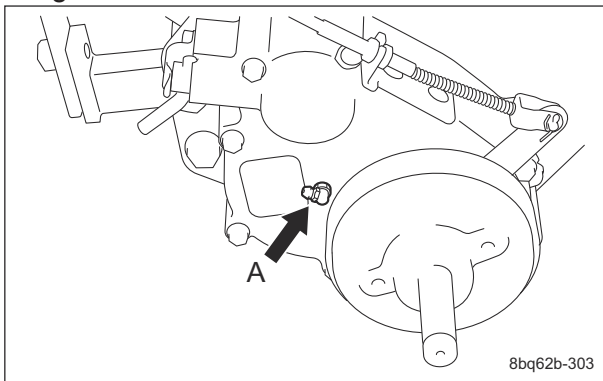

Greasing Points\_007

Maintenance

# Maintenance

Right side

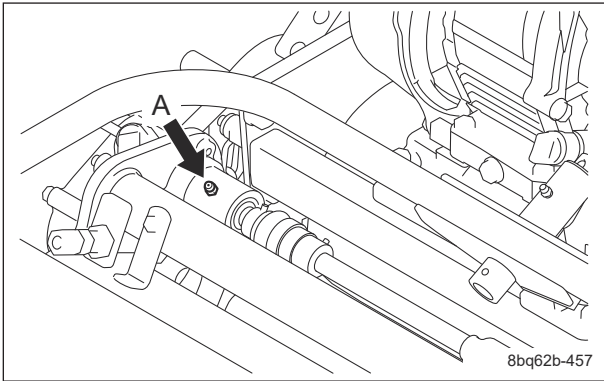

Greasing Points\_011

## 10. Transmission shaft spline

Grease the transmission shaft spline.

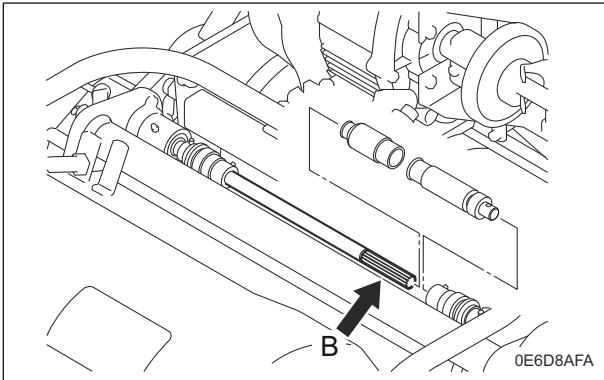

Greasing Points\_012

## 11. Arm mounting hitch fulcrum

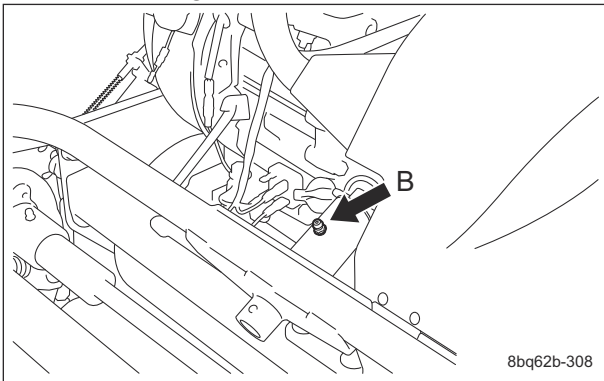

Greasing Points\_013

## 12. Reel housing

There are one location each on the right and left.

Left side

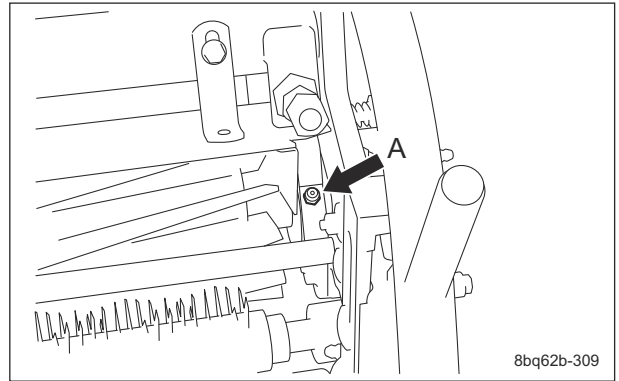

Greasing Points\_014

Right side

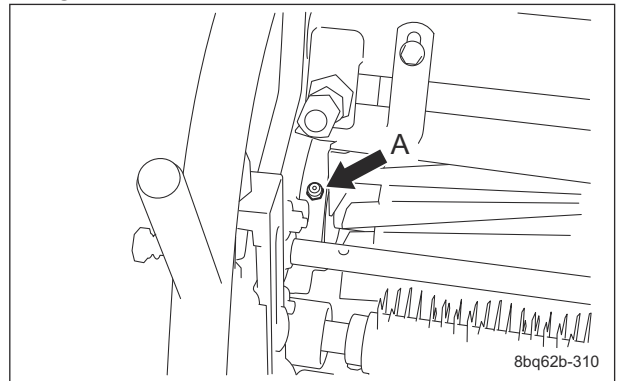

Greasing Points\_015

## 13. Front roller

There are one location each on the right and left.

Left side

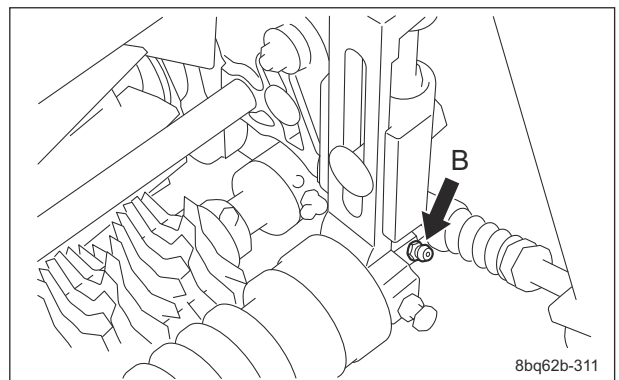

Greasing Points\_016

Right side

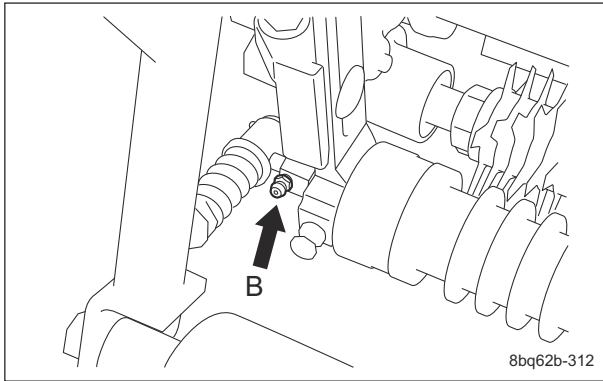

Greasing Points\_017

Right side

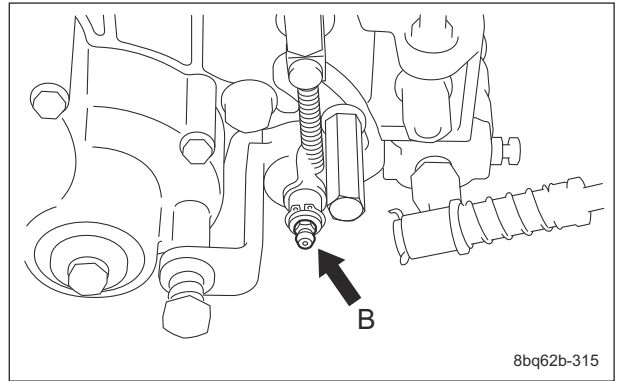

Greasing Points\_020

### 14. Groomer gear case

Note:  
Depending on the specifications, this function may not be available.

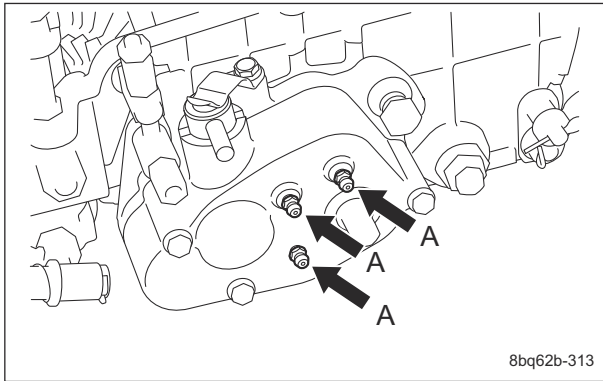

Greasing Points\_018

### 15. Groomer shaft

Note:  
Depending on the specifications, this function may not be available.  
There are one location each on the right and left.

Left side

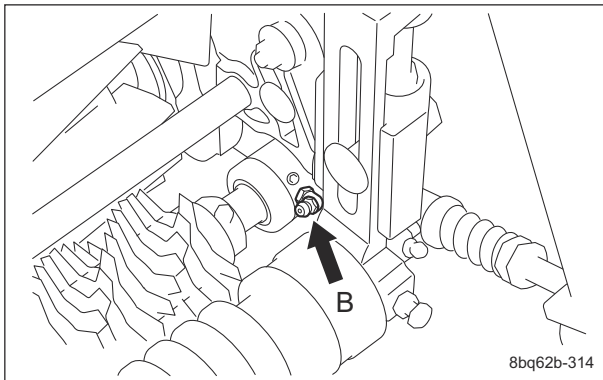

Greasing Points\_019

### 16. Cam bush

There are one location each on the right and left.

Apply 0.5 g (0.001 lb) of grease to outer perimeter of the cam bush pipe according to the maintenance schedule.

Left side

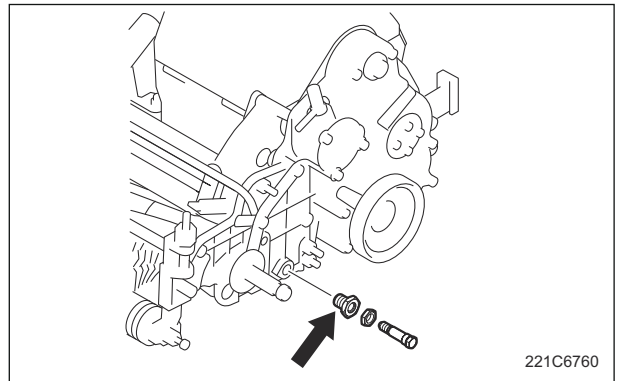

Greasing Points\_021

Right side

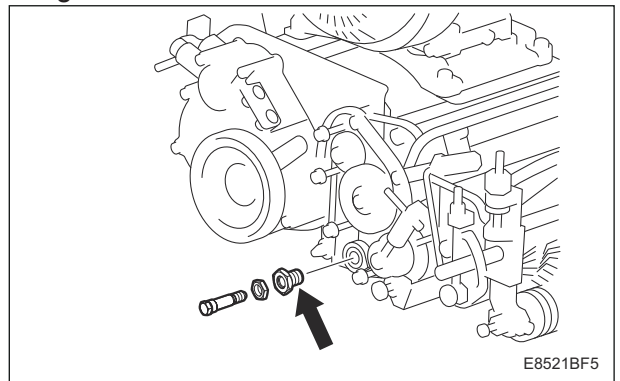

Greasing Points\_022

# Maintenance

## 17. Handle

- Main clutch lever

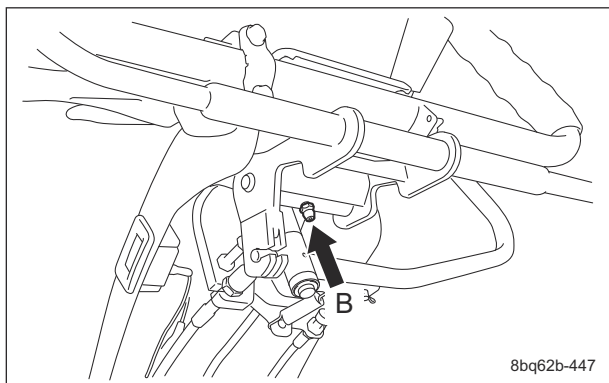

Greasing Points\_023

8bq62b-447

	Location	No. of lubricating points
1	Clutch lock lever fulcrum	2
2	Throttle lever fulcrum	1

### 1. Clutch lock lever fulcrum

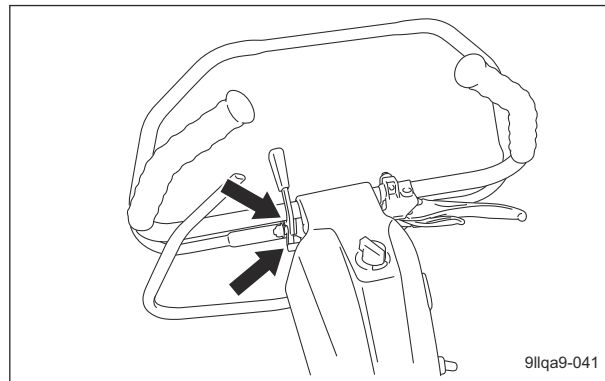

Lubricating Points\_002

9llqa9-041

### 2. Throttle lever fulcrum

Note:

Depending on the specifications, this function may not be available.

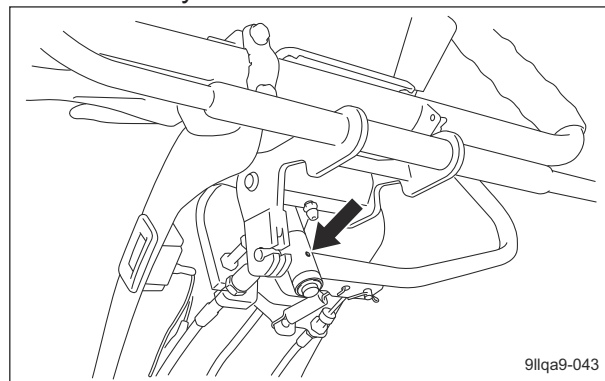

Lubricating Points\_003

9llqa9-043

## Lubrication

### About Lubrication

It is necessary to lubricate moving parts so that they will not become stuck or damaged.

The locations where lubricant is used are indicated in "Lubricating Points".

Apply the lubricant.

### Lubricating Points

There are oil filling ports at the following locations.

Apply lubricant every 50 hours of operation.

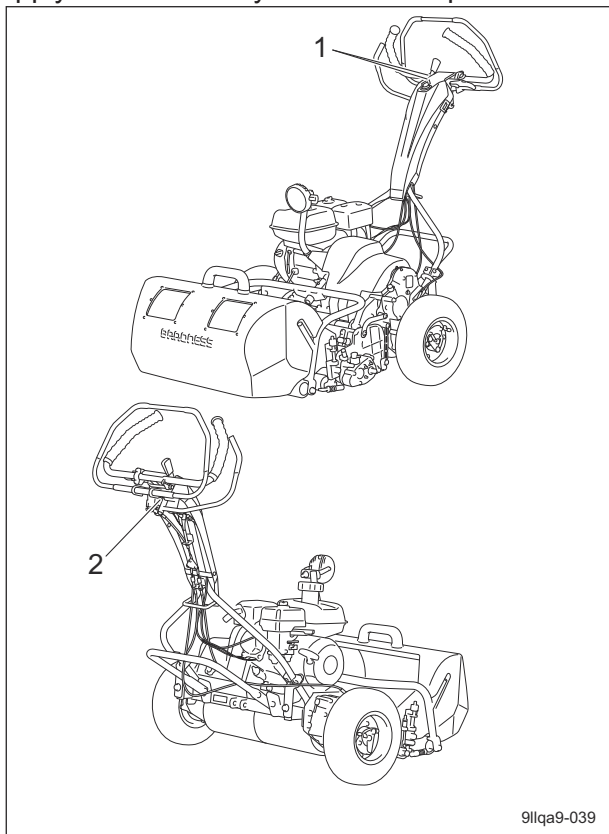

Lubricating Points\_001

9llqa9-039

## Adjustment

### Driving Section

#### Adjustment of Handle Position

The height of the handle can be adjusted according to the operator's working position. Move the handle adjusters supporting the handle up or down and fix them with the bolts.

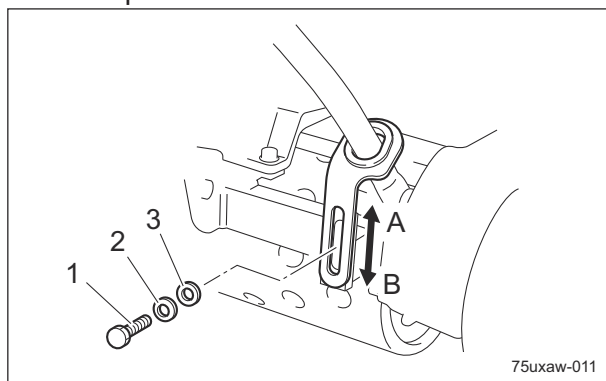

Adjustment of Handle Position\_001

1	Bolt
2	Conical spring washer
3	Washer
A	High
B	Low

### Cutting Section

#### Adjustment of Blade Engagement

##### ⚠ Caution

When checking the sharpness of the blades with newspaper, be sure to stop the engine and protect your hands with gloves etc. Pay attention not to let the reel cutter (cutting cylinder) catch your gloves. Otherwise, you may injure your hand or fingers.

1. Stop the engine.
2. Set the FOC (High/Low Clip) selector lever to the "Stop" position.

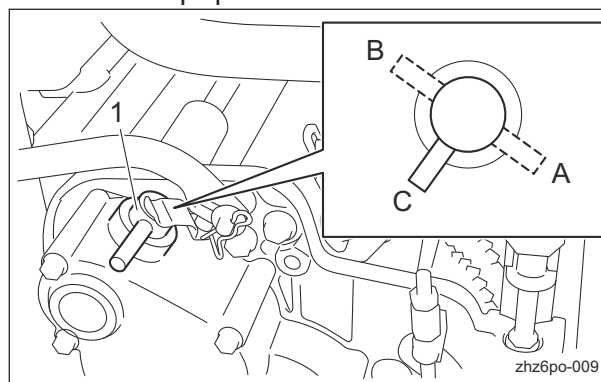

Adjustment of Blade Engagement\_001

1	FOC (High/Low Clip) selector lever
A	Low clip
B	High clip
C	Stop

3. Adjust the engagement between the reel cutter (cutting cylinder) and the bed knife (bottom blade) so that Takumi Paper (Baroness genuine paper strips) or newspaper (one piece) will be cut cleanly by the edge of both blades when the blades in their entirety come slightly into contact with each other via the cutter adjustment nuts.

# Maintenance

4. Insert a strip of Takumi Paper or newspaper into the space between the reel cutter (cutting cylinder) and the bed knife (bottom blade) at an angle of 90 degrees.

Then, rotate the reel cutter (cutting cylinder) counter-clockwise (when you face the cutting section from the left) to check the sharpness of the blades.

Check the sharpness of the entire range (three or four points) of the reel cutter (cutting cylinder).

- If a gap is created between edges:  
Loosen (rotate counter-clockwise) the cutter adjustment nut to apply more contact pressure between the reel cutter (cutting cylinder) and the bed knife (bottom blade).
- If the reel cutter (cutting cylinder) is too tight to turn:  
Tighten (rotate clockwise) the cutter adjustment nut to reduce the contact pressure between the reel cutter (cutting cylinder) and the bed knife (bottom blade).
- If the sharpness is not improved by the adjustment:  
Perform back lapping to the reel cutter (cutting cylinder).

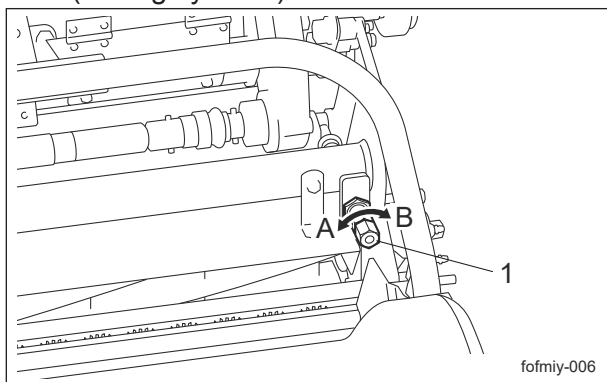

Adjustment of Blade Engagement\_002

1	Cutter adjustment nut
A	Loosen
B	Tighten

## Adjustment of Cutting Height

**Important**

This applies the set cutting height that differs from the actual cutting height.

Adjust the cutting height to fit your cutting work.

■ Cutting Height and Thickness of Bed Knife (Bottom Blade)

**Important**

The recommended minimum cutting heights are based on those of common greens. They may vary according to the green conditions and machine specifications. If the green undulation is hard, set it a little bit higher in order not to damage the green surface.

Minimum cutting height is recommended for each thickness of blade as follows.

Type of blade	Thickness of blade (mm/inch)	Recommended minimum cutting height (mm/inch)	Code	Part name	Remarks
Standard blade	1.5	3.0	K2511000270	1.5 Bed knife (bottom blade) 55G	Standard
	2.0	3.5	K2511000280	2 Bed knife (bottom blade) 55G	
	2.5	4.0	K2511000050	2.5 Bed knife (bottom blade) 55G	
Tipped blade	3.0	4.5	K2510000060	3 Bed knife (bottom blade) 62.5-559	
	5.0	7.0	K2510000160	5 Bed knife (bottom blade) 62.5-559	

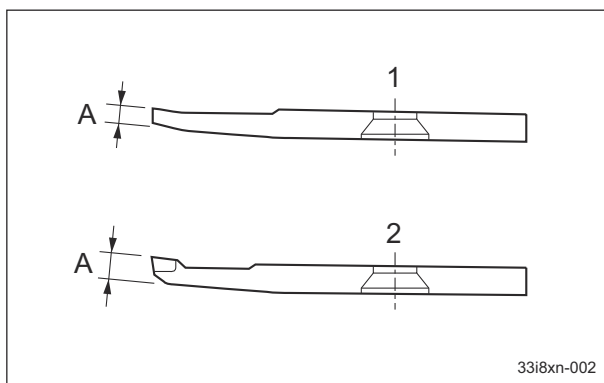

Cutting Height and Thickness of Bed Knife (Bottom Blade)\_001

1	Standard blade
2	Tipped blade
A	Thickness of blade

# Maintenance

## ■ Adjustment of Rear Roller

The rear roller can be adjusted to 3 levels. Adjust the rear roller to a cutting stance that suits the required work.

1. Remove the left and right nut A, washer A, spring washer A, and bolt A.

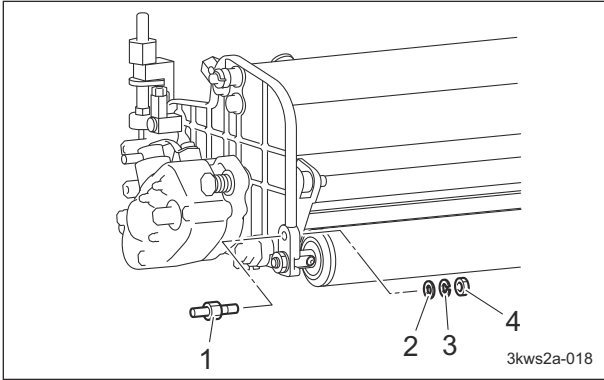

Adjustment of Rear Roller\_001

1	Bolt A
2	Washer A
3	Spring washer A
4	Nut A

2. Remove the left and right washer B and nut B, and remove the rear roller assy from the frame.

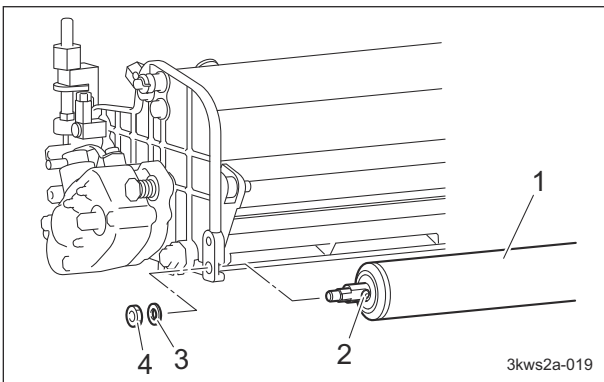

Adjustment of Rear Roller\_002

1	Rear roller assy
2	Bolt B
3	Washer B
4	Nut B

3. Decide on the orientation of bolt B to suit the desired cutting stance, and install the rear roller assy.

### Cutting stance

- Aggressive cutting stance  
Long offset distance and large bed knife angle.

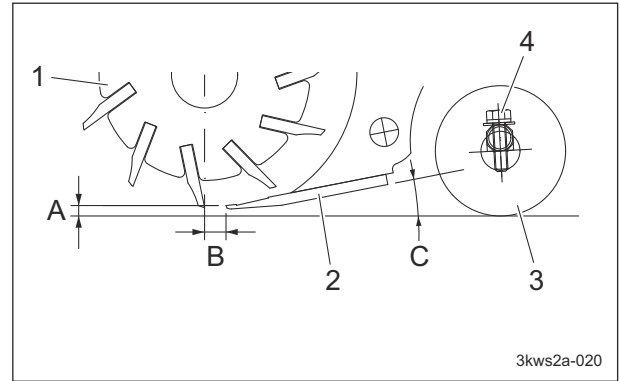

Adjustment of Rear Roller\_003

1	Reel cutter
2	Bed knife
3	Rear roller assy
4	Bolt B
A	Cutting height
B	Offset distance
C	Bed knife angle

- Standard cutting stance

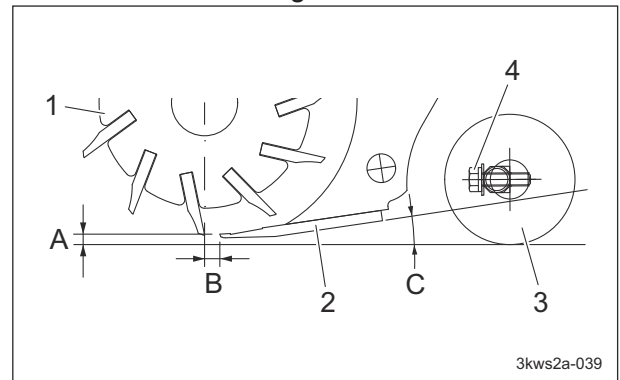

Adjustment of Rear Roller\_004

1	Reel cutter
2	Bed knife
3	Rear roller assy
4	Bolt B
A	Cutting height
B	Offset distance
C	Bed knife angle

- Less aggressive cutting stance  
Short offset distance and small bed knife angle.

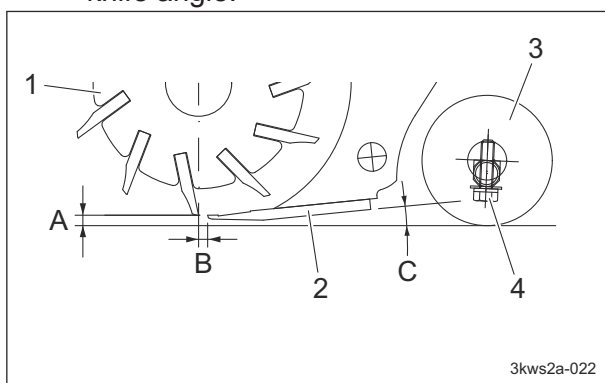

Adjustment of Rear Roller\_005

1	Reel cutter
2	Bed knife
3	Rear roller assy
4	Bolt B
A	Cutting height
B	Offset distance
C	Bed knife angle

### ■ Adjustment of Front Roller

1. Set the slide caliper to the required cutting height, adjust the position of the bottom of the head of the cutting height setting screw on the cutting height gauge, and then securely lock it with a wing nut.

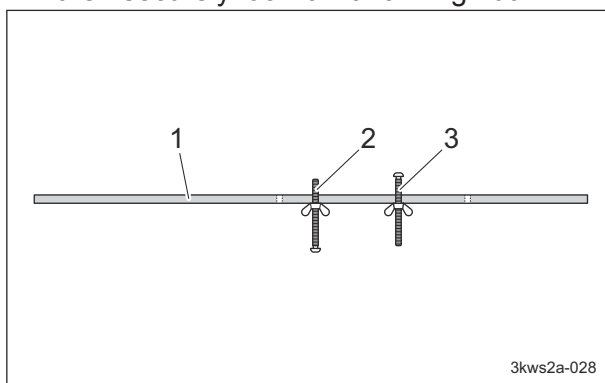

Adjustment of Front Roller\_001

1	Cutting height gauge
2	Groomer setting screw
3	Cutting height setting screw

2. Loosen the left and right nuts that secure the roller bracket.

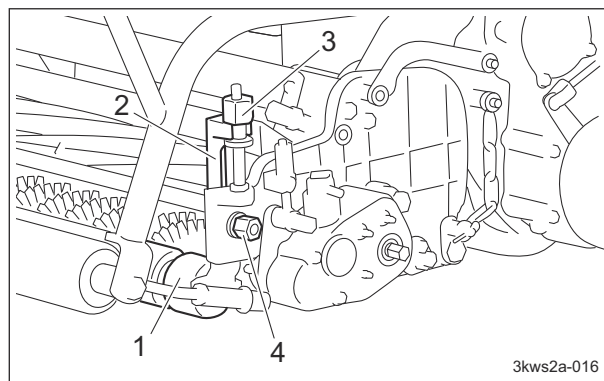

Adjustment of Front Roller\_002

1	Front roller
2	Roller bracket
3	Roller adjustment bracket
4	Nut

3. Bring the cutting height gauge into contact with the front roller and rear roller at the left and right ends of the mowing part.

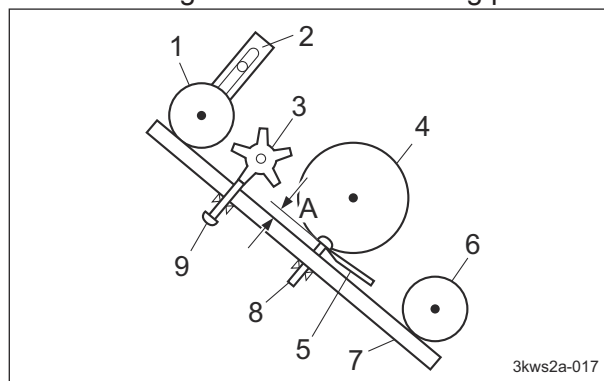

Adjustment of Front Roller\_003

1	Front roller
2	Roller bracket
3	Front groomer
4	Reel cutter
5	Bed knife
6	Rear roller
7	Cutting height gauge
8	Cutting height setting screw
9	Groomer setting screw
A	Cutting height

# Maintenance

4. Raise or lower the front roller with the roller adjustment bracket to set the position of the front roller so that there is no clearance with the bottom of the head of the cutting height setting screw on the cutting height gauge at the tip position of the bed knife.

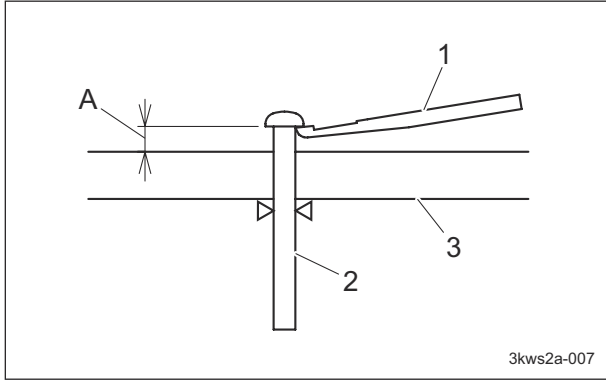

Adjustment of Front Roller\_004

1	Bed knife
2	Cutting height setting screw
3	Cutting height gauge
A	Cutting height

5. Follow the same steps to adjust the cutting height on the opposite side.
6. Tighten the nuts securing the left and right roller brackets, and fix them securely.
7. Bring the cutting height gauge into contact with the front roller and rear roller at the left and right ends of the mowing part again, and check that it is at the desired cutting height.

## Adjustment of Groomer

**Note:**  
Depending on the specifications, this function may not be available.

### Important

When using the front groomer, adjust it to suit the conditions on the green.

### Important

Set the groomer to a height of 0.0 mm (0.0 in) or more above the ground. Setting the front groomer deeper than the ground surface will cause damage to the groomer shaft.

### Important

Setting the front groomer too deep applies too much load to the engine and transmission parts, and will cause malfunctions or damage.

### Important

When using the grooming brush, set it to the same height as the cutting height. If the height of the grooming brush is too low the brush will wear faster.

1. Set the slide caliper to the required groomer height, adjust the tip of the groomer setting screw on the cutting height gauge, and then securely lock it with a wing nut.

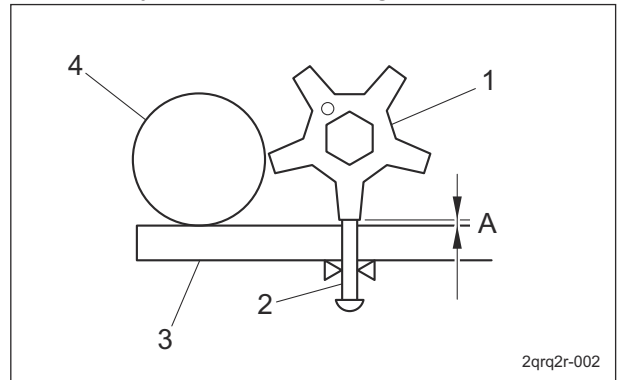

Adjustment of Groomer\_001

1	Vertical blade
2	Groomer setting screw
3	Cutting height gauge
4	Front roller
A	Groomer height

2. Loosen the nut B securing the left side groomer adjustment screw.
3. Loosen the left side high nut.

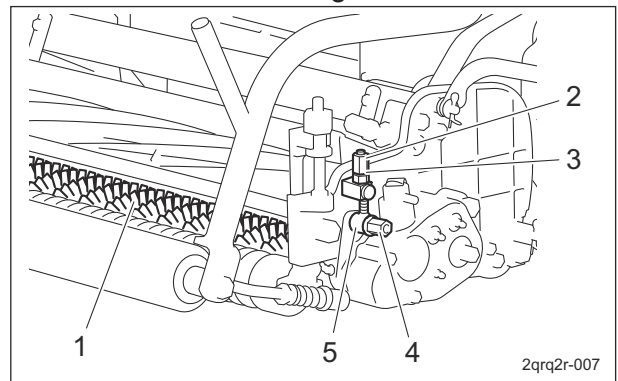

Adjustment of Groomer\_002

1	Front groomer
2	High nut
3	Nut A
4	Nut B
5	Groomer adjustment screw

4. Loosen the bolt securing the right side groomer adjustment screw.

5. Loosen the right side high nut.

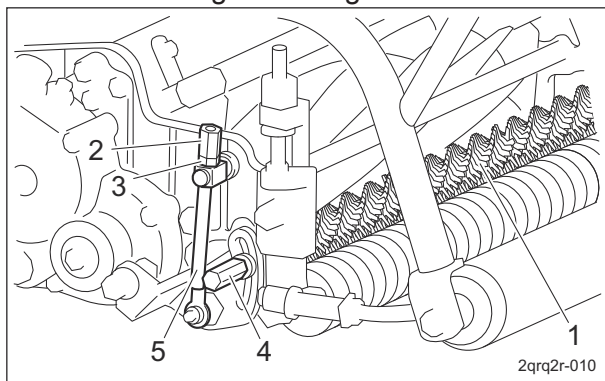

Adjustment of Groomer\_003

1	Front groomer
2	High nut
3	Nut A
4	Bolt
5	Groomer adjustment screw

6. Bring the cutting height gauge into contact with the front roller and rear roller at the left and right ends of the mowing part.

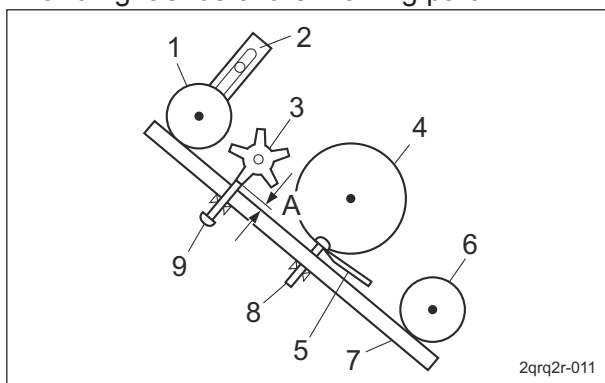

Adjustment of Groomer\_004

1	Front roller
2	Roller bracket
3	Front groomer
4	Reel cutter
5	Bed knife
6	Rear roller
7	Cutting height gauge
8	Cutting height setting screw
9	Groomer setting screw
A	Groomer height

### Important

Adjust the position so that the groomer setting screw can contact the vertical blades.

7. Adjust nut C by raising or lowering it so the left and right are parallel.
8. Firmly tighten the nut B securing the left side groomer adjustment screw.
9. Firmly tighten the bolt securing the right side groomer adjustment screw.
10. Tighten the left and right high nuts.
11. Bring the cutting height gauge into contact with the front roller and rear roller at the left and right ends of the mowing part again, and check that it is at the desired groomer height.

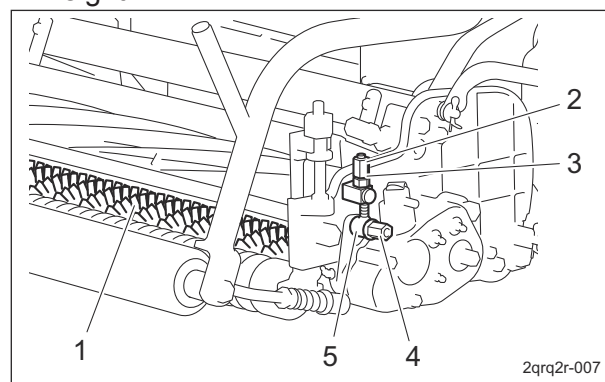

Adjustment of Groomer\_005

1	Front groomer
2	High nut
3	Nut A
4	Nut B
5	Groomer adjustment screw

# Maintenance

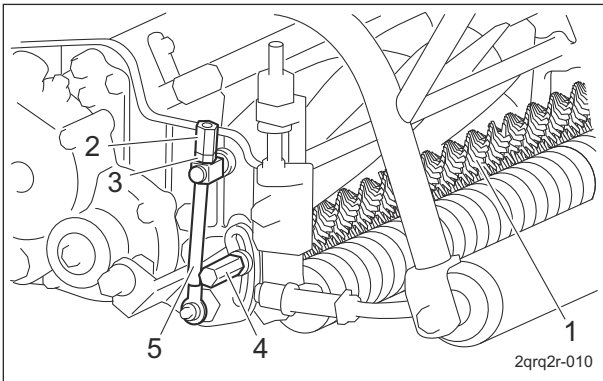

Adjustment of Groomer\_006

1	Front groomer
2	High nut
3	Nut A
4	Bolt
5	Groomer adjustment screw

### Note:

When not using the front groomer, there is no need to change the set height of the groomer.

The front groomer can be raised to a height where it does not make contact with the grass, by loosening the left side nut B and right side bolt securing the groomer adjustment screw, lifting up the front groomer and tightening the left side nut B and right side bolt.

To use the groomer again, the previous height set for the groomer can be restored by loosening the left side nut B and right side bolt, lowering the groomer and tightening the left side nut B and right side bolt.

### Adjustment of Cutter Adjustment Spring

#### ⚠ Caution

When handling the reel cutter (cutting cylinder) and the bed knife (bottom blade), wear gloves to protect your hands. Pay attention not to let the reel cutter (cutting cylinder) catch your gloves. Otherwise, you may injure your hand or fingers.

If the diameter of the reel cutter (cutting cylinder) becomes smaller, adjust the cutter adjustment spring.

1. Adjust the blade engagement.

2. Loosen the spring adjusting screw and the nut, and then adjust the length of the coil spring to approximately 43 mm (1.69 in).

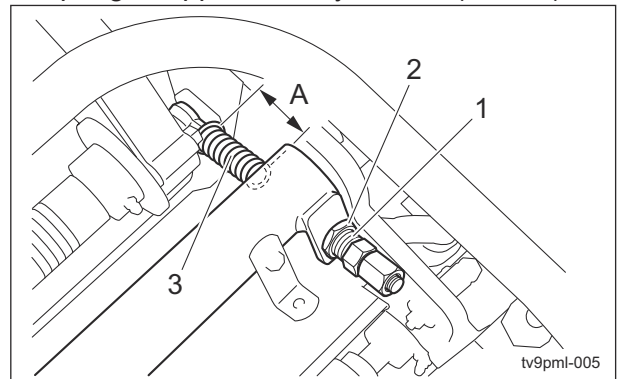

Adjustment of Cutter Adjustment Spring\_001

1	Spring adjusting screw
2	Nut
3	Spring
A	43 mm (1.69 in)

### Adjustment of CAM

Turn the cam bush on both sides of the bed knife (bottom blade), and the blade can be raised and lowered respectively by maximum 0.3 mm (0.012 in).

The above method is used when the edges of the reel cutter (cutting cylinder) and the bed knife (bottom blade) are not in parallel.

Check for the gap between the reel cutter (cutting cylinder) and the bed knife (bottom blade).

Loosen the locknut when adjusting the cam bush.

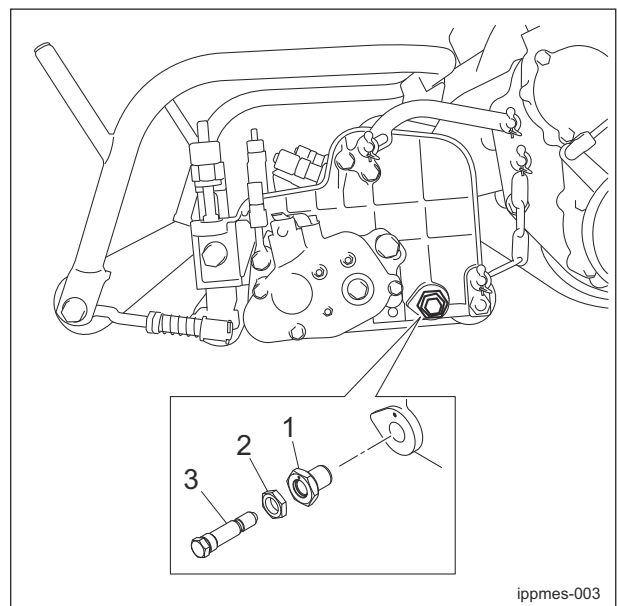

Adjustment of CAM\_001

1	Cam bush
2	Locknut
3	Cutter pin

When the gap appears on the left side.:

1. Turn the left cam bush clockwise to eliminate only the gap distance.  
When you raise the bed knife (bottom blade) by 0.1 mm (0.004 in), turn the left cam bush clockwise 30 degrees.
2. Once the adjustment completed, tighten the locknut securely.

When the gap appears on the right side.:

1. Turn the right cam bush counterclockwise to eliminate only the gap distance.
2. Once the adjustment completed, tighten the locknut securely.

Note:

The figure below shows the situation when you see from the left side.

The right side is mirror reversed.

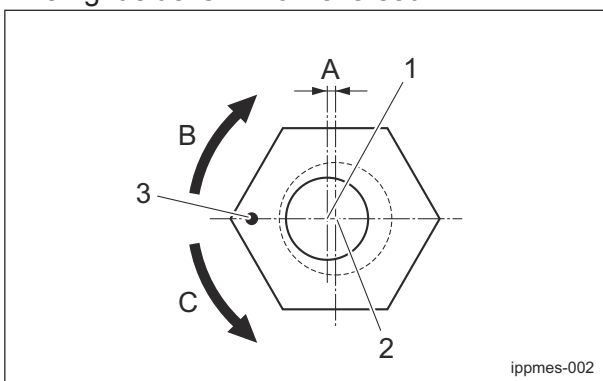

Adjustment of CAM\_002

1	Center of cutter pin
2	Center of cam bush
3	Punch mark
A	0.3 mm (0.012 in)
B	Raising the bed knife
C	Lowering the bed knife.

## Back Lapping

Back lapping is work similar to sharpening a cooking knife. If the edges of the reel cutter (cutting cylinder) and the bed knife (bottom blade) become blunt and make cutting difficult, both the reel cutter (cutting cylinder) and the bed knife (bottom blade) should be simultaneously sharpened by reversing the reel cutter (cutting cylinder) with an abrasive paste applied.

However, back lapping is a temporary measure and would not restore the sharpness completely.

If the edges of the reel cutter (cutting cylinder) and the bed knife (bottom blade) become blunt and make cutting difficult, follow the steps below to perform back lapping.

### Warning

During back lapping, the reel cutter (cutting cylinder) rotates. Keep hands and feet away from moving parts.

### Caution

Do not perform back lapping with any other persons.

1. Have the following items ready: Strips of Takumi Paper (Baroness genuine paper strips) or newspaper, Abrasive [Back lapping powder mixed with oil; or gel compound (Baroness genuine abrasive)], Brush.

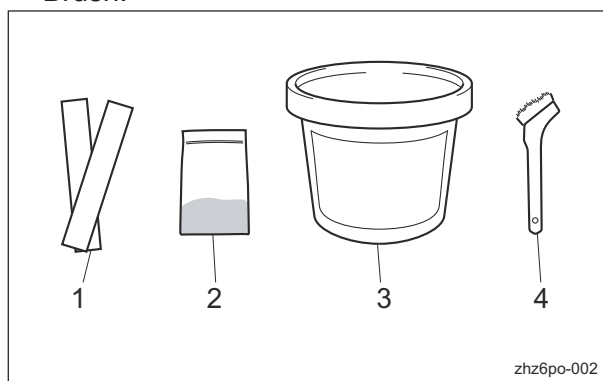

Back Lapping\_001

1	Takumi Paper or newspaper
2	Back lapping powder
3	Gel compound
4	Brush

# Maintenance

**Note:**

The mixing ratio for the abrasive, in volume, is one part back lapping powder (#200 - #400) to three or four parts oil.

2. Have a lapping machine or the lapping handle ready.

**Caution**

When handling the reel cutter (cutting cylinder) and the bed knife (bottom blade), wear gloves to protect your hands. Pay attention not to let the reel cutter (cutting cylinder) catch your gloves. Otherwise, you may injure your hand or fingers.

**Important**

Check the sharpness of the blade by checking the blade engagement after cutting grass.

3. Stop the engine.
4. Shift the the FOC (High/Low Clip) selector lever to the "Stop" position.

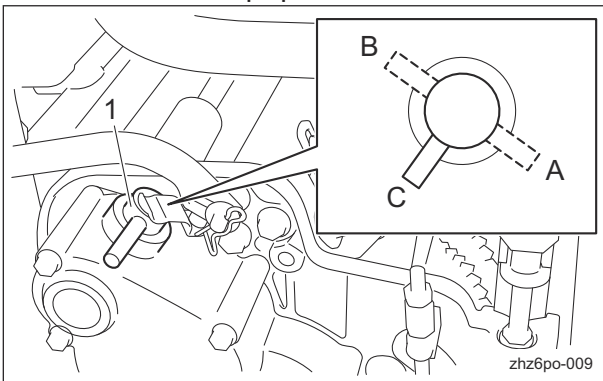

Back Lapping\_002

1	FOC (High/Low clip) Selector Lever
A	High clip
B	Low clip
C	Stop

5. Insert one or two strips of Takumi Paper or newspaper into the space between the reel cutter (cutting cylinder) and the bed knife (bottom blade) at an angle of 90 degrees. Then, rotate the reel cutter (cutting cylinder) counter-clockwise (when you face the mower frame from the left) by hand to check the sharpness of the blades.

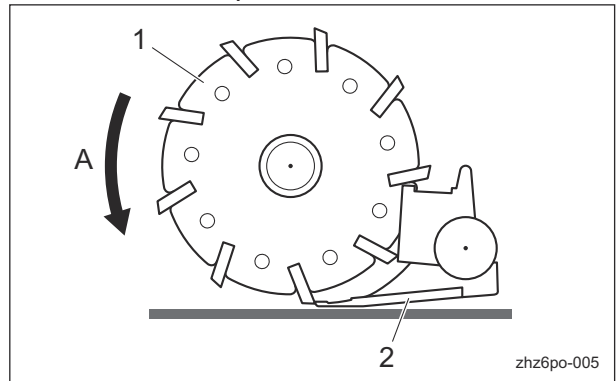

Back Lapping\_003

1	Reel cutter
2	Bed knife
A	Rotation direction

6. Check the sharpness of the entire range (three or four points) of the reel cutter (cutting cylinder).
7. Using a piece of chalk, mark locations on the blade that are sharp.
8. Check the location of the lapping bolt.

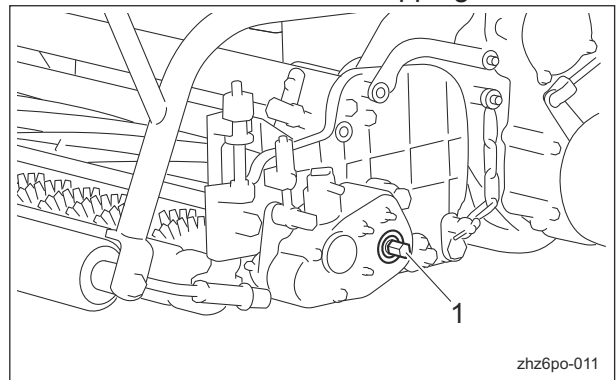

Back Lapping\_004

1	Lapping bolt
---	--------------

9. Connect the lapping machine or the lapping handle to the lapping bolt on the machine.

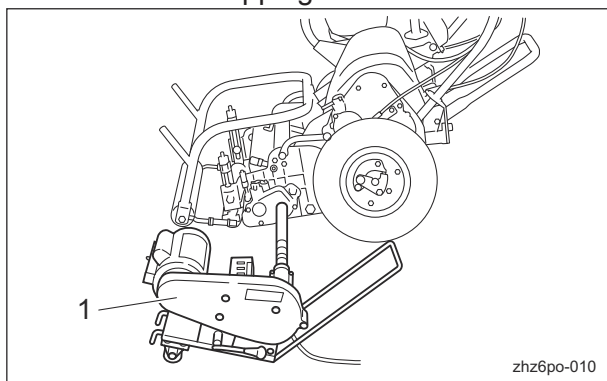

Back Lapping\_005

1	Lapping machine
---	-----------------

10. Rotate the reel cutter (cutting cylinder) clockwise (when you face the mower frame from the left).
- Turn on the lapping machine.
  - Or rotate the lapping handle.

**Important**

The right side of the reel cutter (when you face the mower unit from the front) is inclined to wear earlier than the left side. Accordingly be sure to move the brush from the left to the right to apply the abrasive.

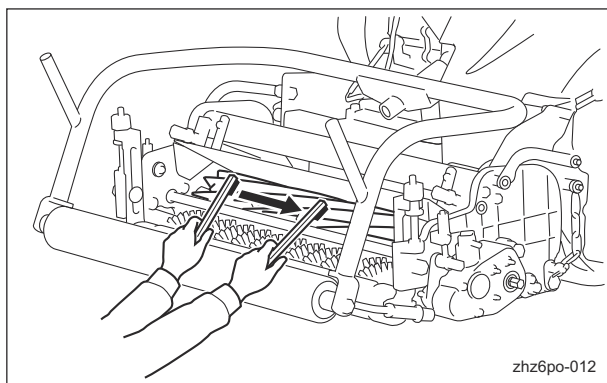

Back Lapping\_006

11. Apply the abrasive evenly with the brush on the top side of reel cutter (cutting cylinder) where strips of Takumi Paper or newspaper were cut well or of chalk-marked locations. (Never apply to blunt areas.)
12. Rotate the reel cutter for a while and stop its rotation when the sound of contact is lost.
- Turn off the lapping machine.
  - Or stop rotating the lapping handle.
13. Disconnect the lapping machine or the lapping handle (accessory tool).

14. Wash off or wipe off with a cloth, etc., the abrasive from the reel cutter (cutting cylinder), and then check it for sharpness.
15. Repeat steps 5 to 13 until the entire range (three or four points) of the reel cutter (cutting cylinder) is uniformly sharpened.
16. Finally, apply abrasive to the entire blade width of the reel cutter (cutting cylinder) and perform final back lapping.

**Important**

Pay attention not to pour water over the engine and electric components when cleaning.

17. Wash out the abrasive with a washer etc.
18. While checking the blade for sharpness, adjust blade engagement.

# Maintenance

## Sharpening of Reel Cutter (Cutting Cylinder)

The sharpening of the reel cutter (cutting cylinder) consists in maintaining its roundness and creating a relief (second edge face). This work should be performed if the sharpness cannot be restored, even after back lapping, or if the relief (second edge face) has worn away.

Sharpen the reel cutter (cutting cylinder) when the sharpness cannot be restored, even after back lapping, or when the relief (second edge face) has worn away, there is full contact or back lapping takes too much time.

In addition, if the reel cutter (cutting cylinder) becomes worn and its shape conical, perform cylindrical grinding to return it to a cylindrical shape.

For sharpening the reel cutter (cutting cylinder), contact your dealer or Baroness unless you have a grinding machine.

**Caution**

Both the reel cutter (cutting cylinder) and the bed knife (bottom blade) are edged tools. Handle them carefully, since they could cut your hands and feet.

**Caution**

Wear gloves when touching edged tools to avoid cutting your hands.

The criteria for sharpening the reel cutter (cutting cylinder) are described below. However, these criteria are only references and do not guarantee performance of a reel cutter (cutting cylinder).

1. If the outer diameter of the reel cutter (cutting cylinder) after sharpening is more than the usage limit, the reel cutter (cutting cylinder) can be sharpened.

New		Usage limit	
Dimension A (Outer diameter of reel cutter (cutting cylinder))	Dimension B (Distance from blade edge to outer edge of reel cutter (cutting cylinder) shaft)	Dimension A (Outer diameter of reel cutter (cutting cylinder))	Dimension B (Distance from blade edge to outer edge of reel cutter (cutting cylinder) shaft)
101 mm (3.98 in)	37.8 mm (1.49 in)	93 mm (3.66 in)	33.8 mm (1.33 in)

**Note:**

The outer diameter of the reel cutter (cutting cylinder) shaft is 25.4 mm (1.00 in).

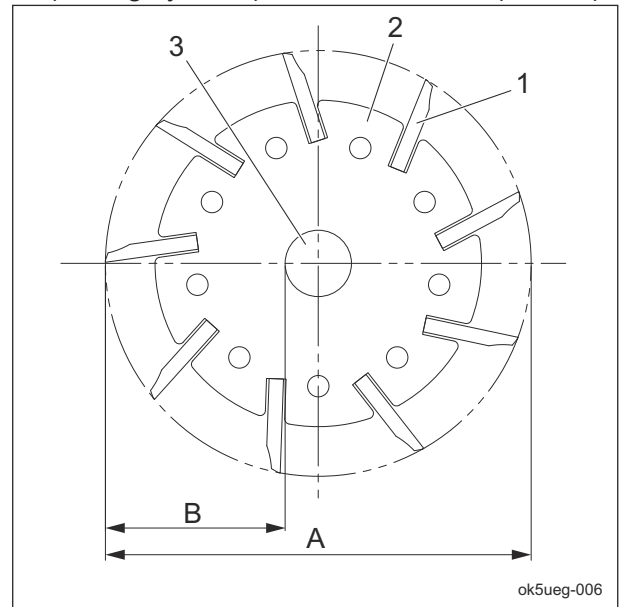

Sharpening of Reel Cutter (Cutting Cylinder)\_001

1	Reel cutter (cutting cylinder) blade
2	Reel cutter (cutting cylinder) disc
3	Reel cutter (cutting cylinder) shaft
A	Outer diameter of reel cutter (cutting cylinder)
B	Distance from blade edge to outer edge of reel cutter (cutting cylinder) shaft

2. Sharpening is necessary when the reel cutter (cutting cylinder) reaches a condition described below.

- [1] When the sharpening width (length of contacting surface of bed knife (bottom blade)) for the outer diameter of the reel cutter (cutting cylinder) is greater than the usage limit.

Outer diameter of reel cutter (cutting cylinder) (new part)	Usage limit of sharpening width for outer diameter of reel cutter (cutting cylinder)
101 mm (3.98 in)	2.5 mm (0.10 in) (factory-recommended)

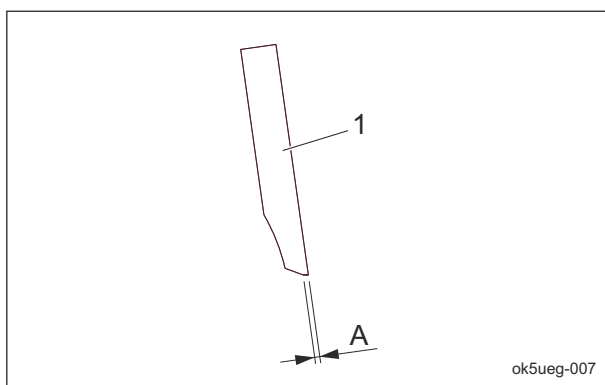

Sharpening of Reel Cutter (Cutting Cylinder)\_002

1	Reel cutter (cutting cylinder) blade
A	Sharpening width for outer diameter of reel cutter (cutting cylinder)

[2] When the edges become blunt or the blade edge cannot be formed with back lapping

[3] When the reel cutter (cutting cylinder) becomes worn and its shape conical, or when blade engagement adjustment cannot be performed

## Replacement

### Engine

#### Replacement of Engine Oil

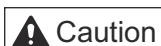

**Caution**  
Be careful with hot oil, which could cause burns if it contacts your skin.

#### Important

When you replace the engine oil, be sure to drain it into a bowl and discard it in accordance with local laws and regulations.

#### Important

Be sure to use engine oil that is classified as API Service Grade SE or higher, with an SAE Viscosity that is appropriate for the operating environment (ambient temperature).

#### Important

When installing the oil level gauge, tighten it securely.

Replace the engine oil more frequently if the engine oil is contaminated, and especially if you use the machine in dusty areas or operate the engine at high loads or in high temperatures.

1. Follow the steps below to remove the old engine oil.

[1] Start and run the engine to warm up the engine oil.

[2] With the machine on a level surface, stop the engine.

[3] Remove the drain plug, and then drain the old engine oil into a container.

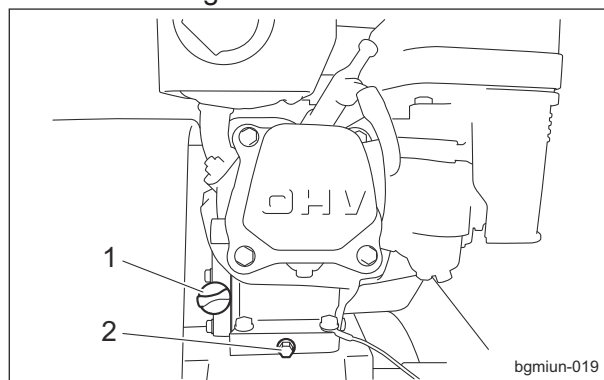

Replacement of Engine Oil\_001

1	Oil level gauge (Oil filler port)
2	Drain plug

[4] Re-place the drain plug onto the engine.

2. Remove the oil level gauge.

Supply oil until it reaches a level in the upper limit line on the oil level gauge.

The engine oil quantity is approximately 0.56 dm<sup>3</sup> (0.56 L).

3. Securely tighten the oil level gauge.

# Maintenance

4. Check underneath the machine for oil leakage.

## Replacement of Air Cleaner Element

**Important**

A contaminated air cleaner element may cause malfunction of the engine.

1. The timing for replacing the air cleaner element is described below.
  - [1] Replace the air cleaner element in accordance with the Maintenance Schedule.
  - [2] If it is significantly contaminated, replace it, even if the hours of operation do not exceed the specified time.
2. Replace the air cleaner element by following the same steps as for cleaning the air cleaner element. "Cleaning of Air Cleaner Element" (Page 6-4)

## Cutting Section

### Replacement of Reel Cutter (Cutting Cylinder)

**Caution**

Both the reel cutter (cutting cylinder) and the bed knife (bottom blade) are edged tools. Handle them carefully, since they could cut your hands and feet.

**Caution**

Wear gloves when touching edged tools to avoid cutting your hands.

The criteria for replacing the reel cutter (cutting cylinder) are described below. However, these criteria are only a reference and do not guarantee performance like that of a new reel cutter (cutting cylinder).

1. When the outer diameter of the reel cutter (cutting cylinder) is less than the usage limit

New		Usage limit	
Dimension A (Outer diameter of reel cutter (cutting cylinder))	Dimension B (Distance from blade edge to outer edge of reel cutter (cutting cylinder) shaft)	Dimension A (Outer diameter of reel cutter (cutting cylinder))	Dimension B (Distance from blade edge to outer edge of reel cutter (cutting cylinder) shaft)
101 mm (3.98 in)	37.8 mm (1.49 in)	93 mm (3.66 in)	33.8 mm (1.33 in)

Note:  
The outer diameter of the reel cutter (cutting cylinder) shaft is 25.4 mm (1.00 in).

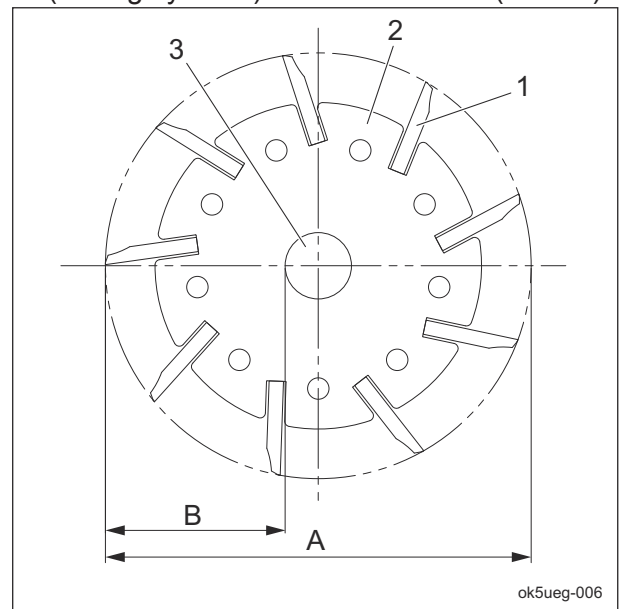

Replacement of Reel Cutter (Cutting Cylinder)\_001

1	Reel cutter (cutting cylinder) blade
2	Reel cutter (cutting cylinder) disc
3	Reel cutter (cutting cylinder) shaft
A	Outer diameter of reel cutter (cutting cylinder)
B	Distance from blade edge to outer edge of reel cutter (cutting cylinder) shaft

### ■ Installation of The Reel Cutter

#### ⚠ Caution

Both the reel cutter (cutting cylinder) and the bed knife (bottom blade) are edged tools. Handle them carefully, since they could cut your hands and feet.

#### ⚠ Caution

When handling the reel cutter (cutting cylinder) and the bed knife (bottom blade), wear gloves to protect your hands. Pay attention not to let the reel cutter (cutting cylinder) catch your gloves. Otherwise, you may injure your hand or fingers.

Follow the instruction below to replace the reel cutter bearing and oil seal on both sides.

#### Important

Use Bearing 30204JRP6.

1. Fill up the bearings and oil seals with grease (Excelite EP No.2).
2. Attach the reel cutter (cutting cylinder) to the frame.
3. Tighten the nut completely and temporarily, and then loosen it until the spring length reaches 11.5 mm(0.453 in) and lock it.

Note:

A certain preload will be applied by the spring pressure.

4. Measure the rotational torque of the blade reel cylinder with a torque wrench. The specified value should be 0.8 to 1.0 N m (8 to 10 kgf cm).

Mower without Groomer:

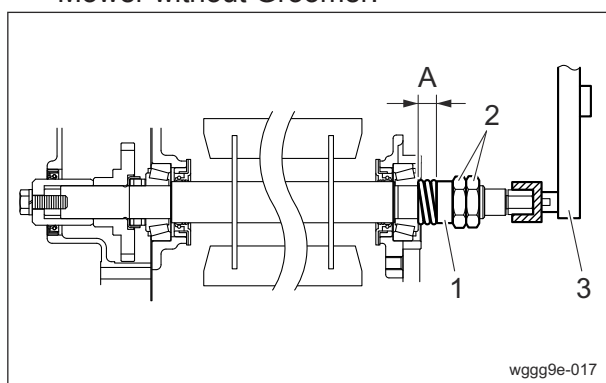

Installation of The Reel Cutter\_001

1	Collar
2	Nut
3	Torque wrench
A	11.5 mm (0.453 in)

Mower with Groomer:

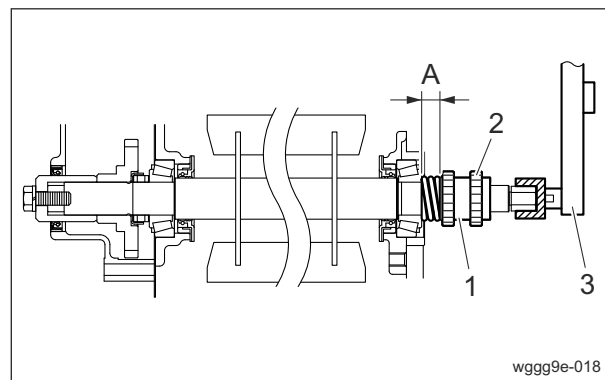

Installation of The Reel Cutter\_002

1	Reel gear
2	Gear nut
3	Torque Wrench
A	11.5 mm (0.453 in)

### Replacement of Bed Knife (Bottom Blade)

#### ⚠ Caution

Both the reel cutter (cutting cylinder) and the bed knife (bottom blade) are edged tools. Handle them carefully, since they could cut your hands and feet.

#### ⚠ Caution

Wear gloves when touching edged tools to avoid cutting your hands.

The criteria for replacing the bed knife (bottom blade) are described below. However, these criteria are only a reference and do not guarantee performance like that of a new bed knife (bottom blade).

1. When the reel cutter (cutting cylinder) is ground
2. When the reel cutter (cutting cylinder) is replaced
3. When the bed knife (bottom blade) is worn

# Maintenance

## Standard blade

Replace the bed knife (bottom blade) before it no longer has a front face.

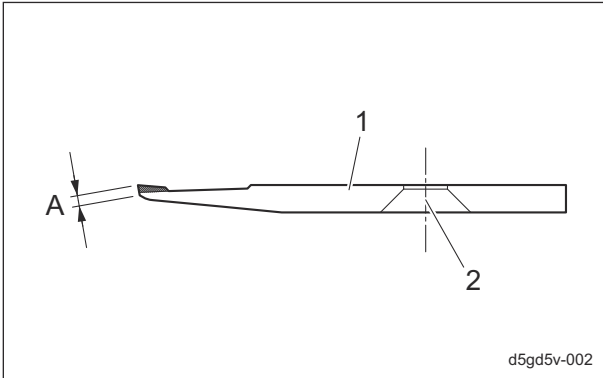

Replacement of Bed Knife (Bottom Blade)\_001

1	Bed knife (bottom blade)
2	Mounting hole
A	Front face

1. Lower the roller bracket so that it does not contact the reel cover, and then remove the bolts.

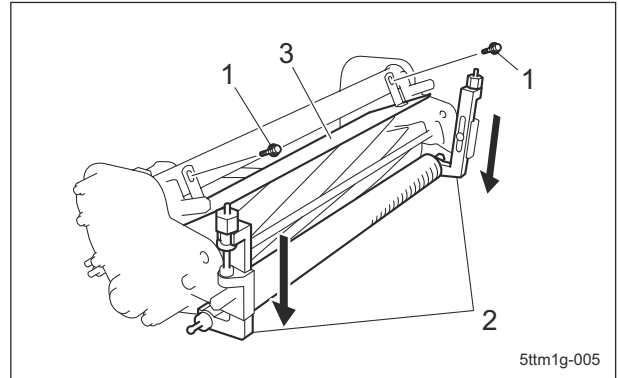

Removal of Bed Knife Base\_001

1	Bolt
2	Roller bracket
3	Reel cover

## Procedure to Remove/Install The Bed Knife Base

### ■Removal of Bed Knife Base

#### ⚠ Caution

Both the reel cutter (cutting cylinder) and the bed knife (bottom blade) are edged tools. Handle them carefully, since they could cut your hands and feet.

#### ⚠ Caution

Wear gloves when touching edged tools to avoid cutting your hands.

#### ⚠ Caution

While operations are performed with the front of the machine raised, it may fall. Securely support the machine.

2. Remove the reel cover.

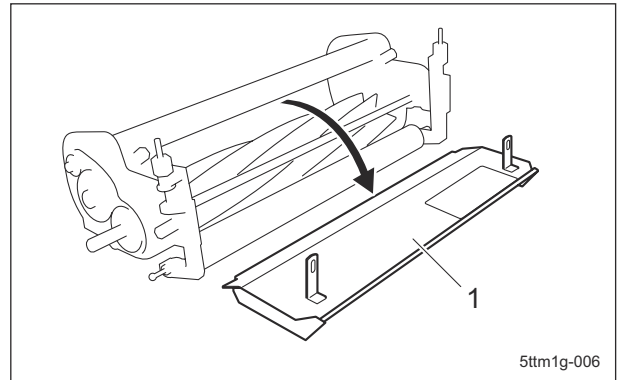

Removal of Bed Knife Base\_002

1	Reel cover
---	------------

3. Turn over the cutting section.

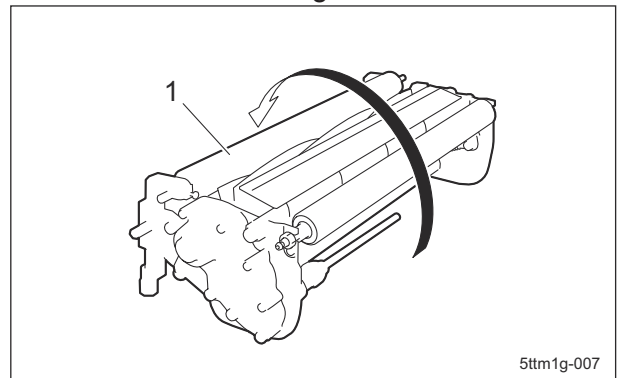

Removal of Bed Knife Base\_003

1	Cutting section
---	-----------------

4. Remove the bolts, and then remove the rear roller Assy.

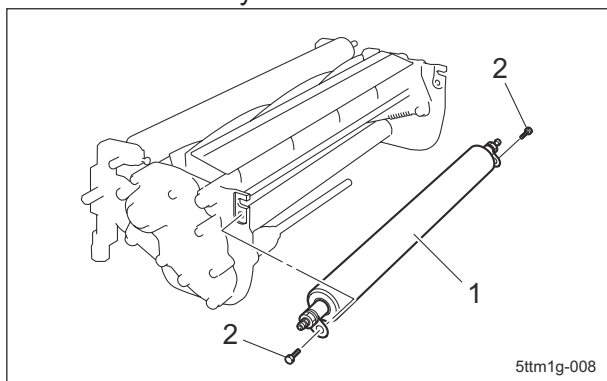

Removal of Bed Knife Base\_004

1	Rear roller Assy
2	Bolt

5. Loosen the left and right lock nuts, and then remove the cutter pins.

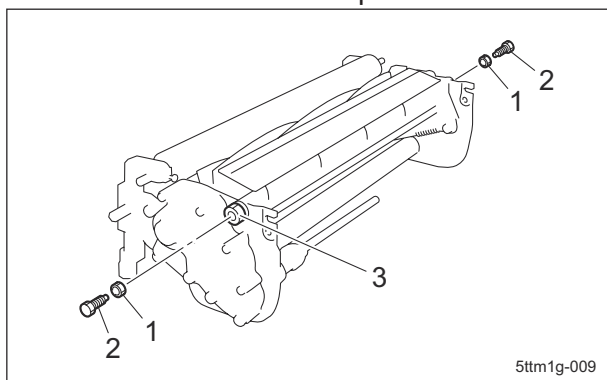

Removal of Bed Knife Base\_005

1	Lock nut
2	Cutter pin
3	Cam bush

6. Stand up the cutting section so that the roller bracket is at the top, and then remove the left and right cutter adjustment nuts.

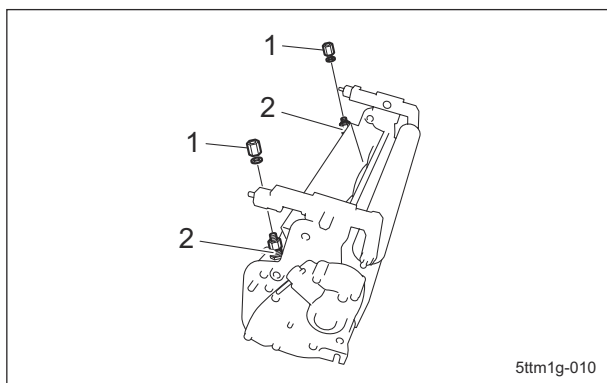

Removal of Bed Knife Base\_006

1	Cutter adjustment nut
2	Cutter adjustment bolt

7. Place down the cutting section, and then remove the bed knife base COMP.

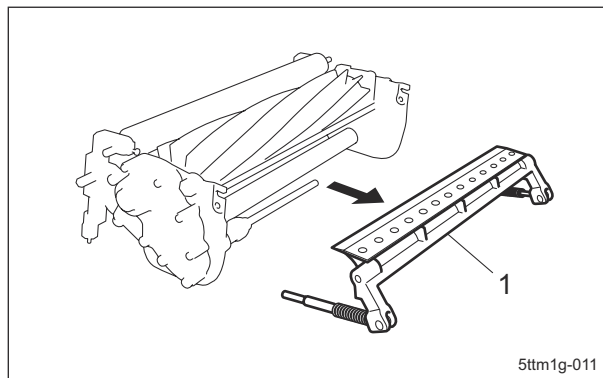

Removal of Bed Knife Base\_007

1	Bed knife base COMP
---	---------------------

# Maintenance

## ■ Installation of Bed Knife Base

### ⚠ Caution

Both the reel cutter (cutting cylinder) and the bed knife (bottom blade) are edged tools. Handle them carefully, since they could cut your hands and feet.

### ⚠ Caution

When handling the reel cutter (cutting cylinder) or bed knife (bottom blade), wear gloves to protect your hands. Pay attention not to let the reel cutter (cutting cylinder) catch your gloves. Otherwise, you may injure your hand or fingers.

### ⚠ Caution

While operations are performed with the front of the machine raised, it may fall. Securely support the machine.

### Important

Make sure that there is no binding at the cam bushes in the mower frame.

1. Remove the right and left cam bushes.
2. Clean the cam bushes and the cam bush attaching portions on the frame side, and apply grease.
3. Install the cam bushes.
4. Remove the collar and compression spring from each (left and right) cutter adjustment bolt, and then temporarily install the bed knife base COMP onto the mower frame.

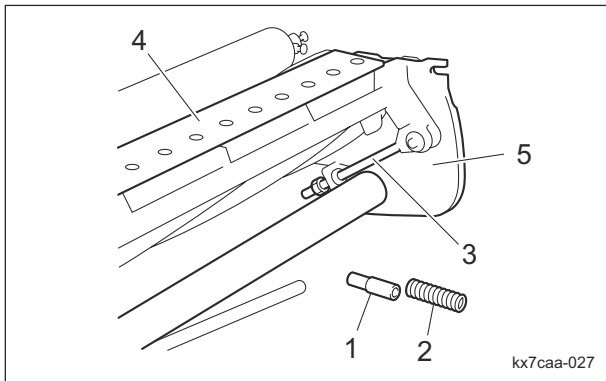

Installation of Bed Knife Base\_001

1	Collar
2	Compression spring
3	Cutter adjustment bolt
4	Bed knife base COMP
5	Mower frame

5. Temporarily install the left and right cutter pins.

### Note:

At this time, tighten the lock nuts to the heads of the cutter pins, but do not allow the lock nuts to contact the cam bushes.

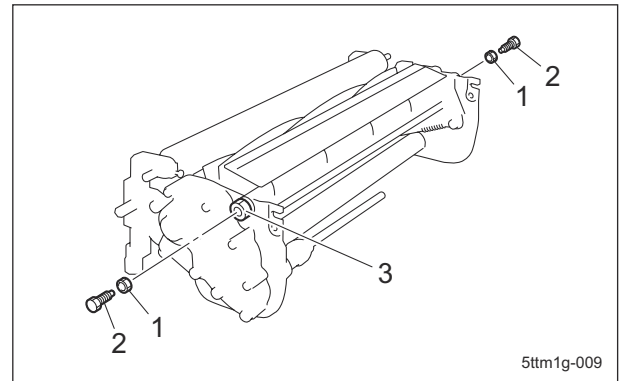

Installation of Bed Knife Base\_002

1	Lock nut
2	Cutter pin
3	Cam bush

6. Align the punch mark on each (left and right) cam bush with the traveling direction.

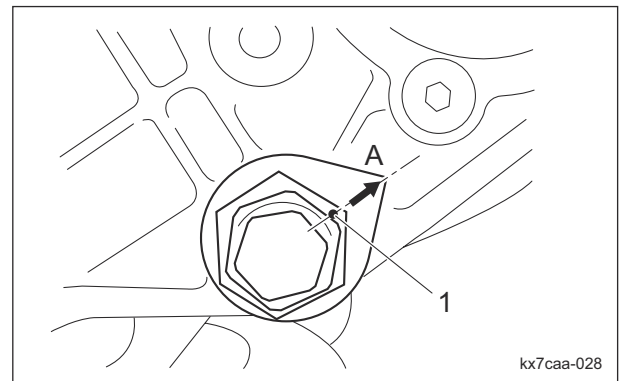

Installation of Bed Knife Base\_003

1	Punch mark
A	Traveling direction

7. Make sure that the bed knife (bottom blade) contacts the reel cutter (cutting cylinder).

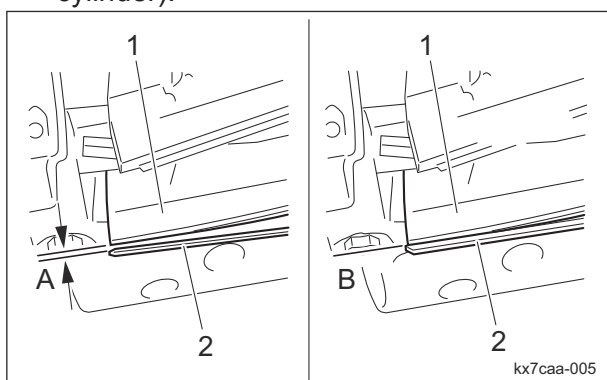

Installation of Bed Knife Base\_004

1	Reel cutter (cutting cylinder)
2	Bed knife (bottom blade)
3	Gap
4	No gap

8. Insert one or two strips of newspaper into the space between the reel cutter (cutting cylinder) and the bed knife (bottom blade) at an angle of 90 degrees. Then, rotate the reel cutter (cutting cylinder) counterclockwise (as seen from the left side of the mower frame) by hand to check the sharpness of the entire range (three or four points) of the reel cutter (cutting cylinder).

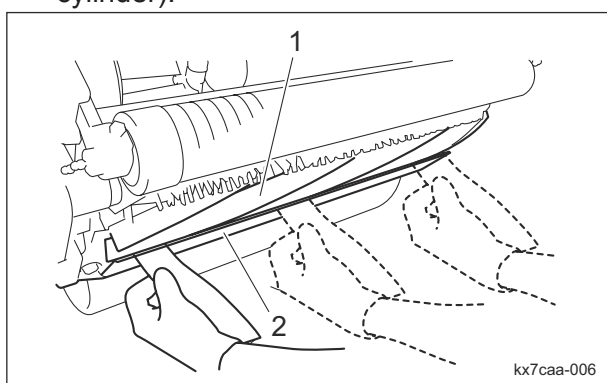

Installation of Bed Knife Base\_005

1	Reel cutter (cutting cylinder)
2	Bed knife (bottom blade)

9. Adjust the positions of the cam bushes so that both sides cut.

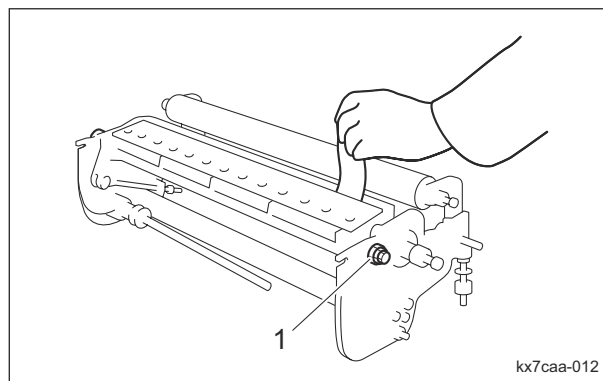

Installation of Bed Knife Base\_006

1	Cam bush
---	----------

10. Use a marker, etc., to place a mark on the mower frame at the position of the punch mark on the cam bush, and then remove the cutter pin.

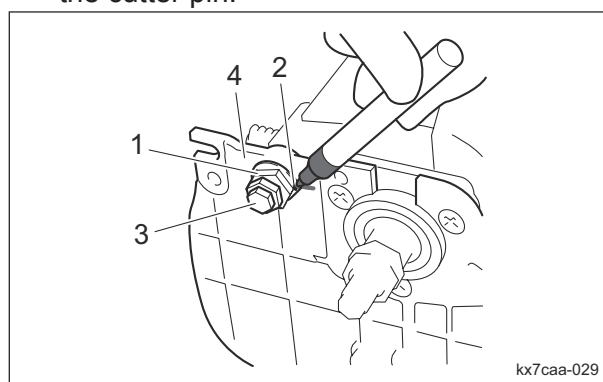

Installation of Bed Knife Base\_007

1	Cam bush
2	Punch mark
3	Cutter pin
4	Mower frame

11. Remove the bed knife base COMP, and then install the compression springs and collars onto the left and right cutter adjustment bolts.

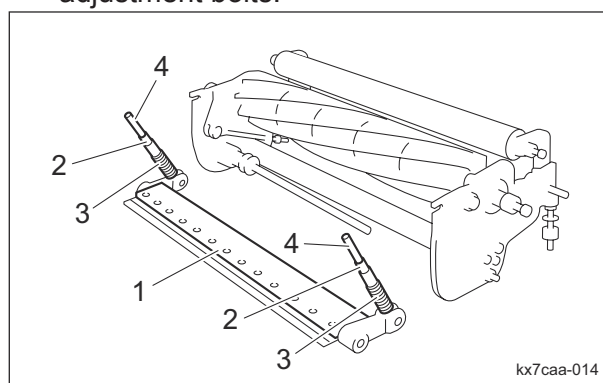

Installation of Bed Knife Base\_008

# Maintenance

1	Bed knife base COMP
2	Collar
3	Compression spring
4	Cutter adjustment bolt

12. Install the bed knife base COMP.
13. Tighten the left and right cutter adjustment nuts evenly on both sides so that the cutter pin mounting holes of the bed knife base and cam bush are aligned.

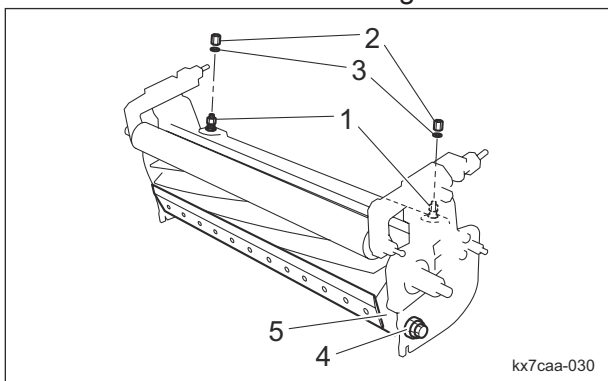

Installation of Bed Knife Base\_009

1	Cutter adjustment bolt
2	Cutter adjustment nut
3	Washer
4	Cam bush
5	Bed knife base

**Important**

Make sure that the cam bush does not move from the marked position.

14. Install the lock nut to each (left and right) cutter pin.
15. Tighten the cutter pin into the cutter pin mounting holes of the bed knife base and cam bush, and then tighten the lock nut to fix it.

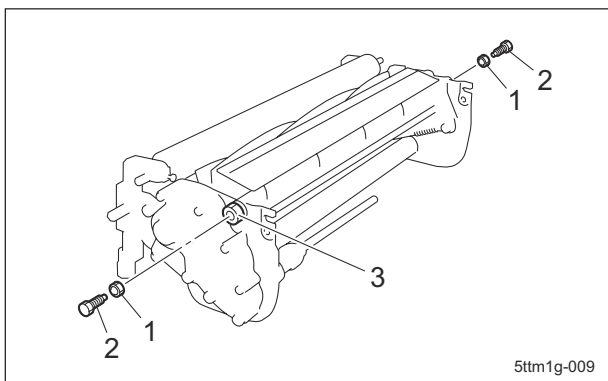

Installation of Bed Knife Base\_010

1	Lock nut
2	Cutter pin
3	Cam bush

16. Install the rear roller Assy.

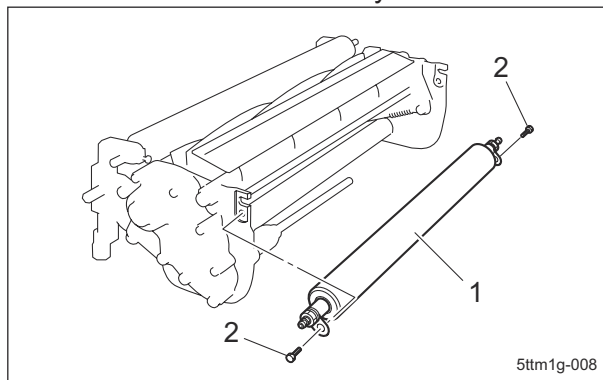

Installation of Bed Knife Base\_011

1	Rear roller Assy
2	Bolt

17. Install the reel cover and then tighten the bolts to fix it.

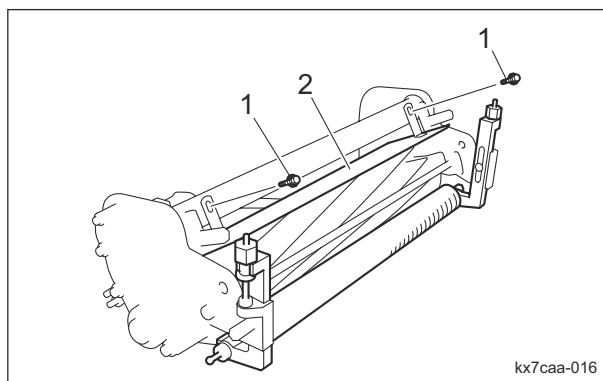

Installation of Bed Knife Base\_012

1	Bolt
2	Reel cover

18. Adjust the cutting height.

## Procedure to Remove/Install The Bed Knife

### ■Removal of The Bed Knife

**Caution**

Both the reel cutter (cutting cylinder) and the bed knife (bottom blade) are edged tools. Handle them carefully, since they could cut your hands and feet.

**Caution**

Wear gloves when touching edged tools to avoid cutting your hands.

**Caution**

While operations are performed with the front of the machine raised, it may fall. Securely support the machine.

1. Remove the bed knife base COMP.
2. Place the bed knife base COMP on a stable workbench.
3. Remove the bed knife by loosening the screw with a hammer driver or punch.

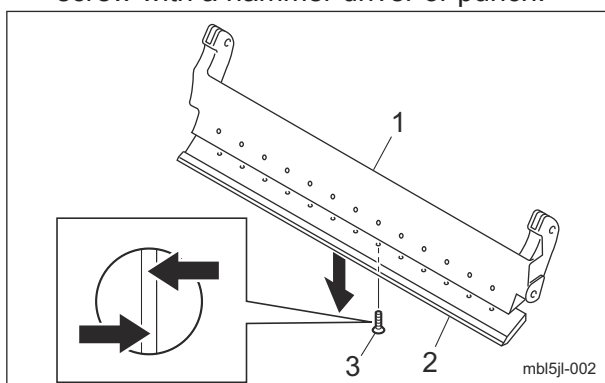

Removal of The Bed Knife\_001

1	Bed knife base
2	Bed knife
3	Screw

### ■Installation of The Bed Knife

**Caution**

Both the reel cutter (cutting cylinder) and the bed knife (bottom blade) are edged tools. Handle them carefully, since they could cut your hands and feet.

**Caution**

Wear gloves when touching edged tools to avoid cutting your hands.

**Caution**

While operations are performed with the front of the machine raised, it may fall. Securely support the machine.

**Important**

Be sure not to scratch the bed knife base surface where the bed knife shall be mounted. Remove rust and dust.

**Important**

Replace the old screws with new ones.

1. Tighten the screws uniformly with a hammer driver.

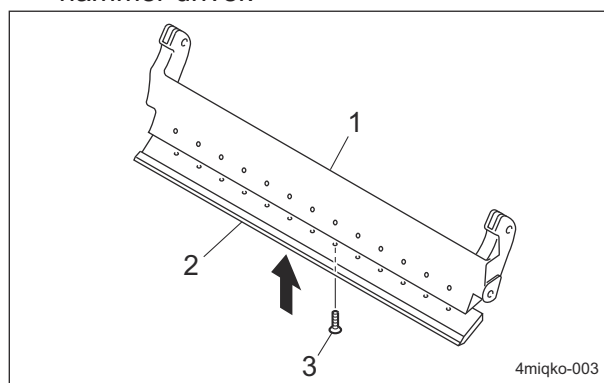

Installation of The Bed Knife\_001

1	Bed knife base
2	Bed knife
3	Screw

**Note:**

When installing the bed knife, first tighten the center screw, and then tighten from center outwards, alternating between left and right sides.

# Maintenance

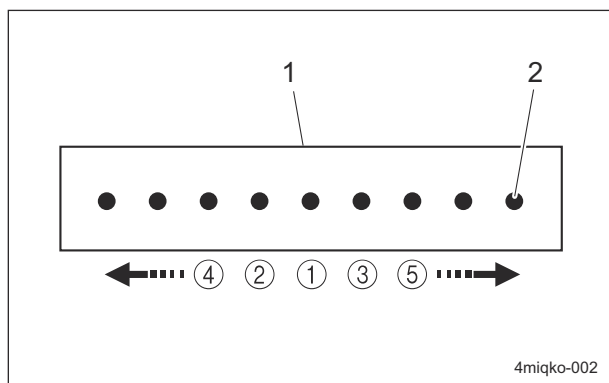

Installation of The Bed Knife\_002

1	Bed knife
2	Screw

## Storage

### Long-Term Storage

Follow the instructions below for long-term storage of the machine.

#### 1. Cleaning

- Remove dirt, grass clippings, oil stains etc. completely from the main vehicle and engine.

#### 2. Replacing oil

- Inspect and replace the engine oil and element.

#### 3. Oil filling

- Grease and lubricate the appropriate points.

#### 4. Fuel

- Remove the fuel from the fuel tank.

#### 5. Tire pneumatic pressure

- Set the tire air pressure slightly higher than normal, and then place the machine on a board to avoid humidity.

#### 6. Storage location

- Cover the machine and store it in a dry place where it will not be exposed to rain.

**Precautions for Repair ..... Page 7-2**

**Adjustment ..... Page 7-2**

Adjustment of Brake ..... Page 7-2

Adjustment of Engine Clutch Section .... Page 7-2

# Repair

## Precautions for Repair

### Warning

The chapter "Repair" in this manual describes practical measures which should be performed by a mechanic with expertise. The owner should instruct the mechanic with expertise to perform repair service for this machine.

### Caution

First, learn well the operations you plan to perform.

### Important

Use tools appropriate for each operation.

### Important

Use Baroness genuine parts for replacement and accessories.  
Our product warranty may be void if you use non-genuine parts for replacement or accessories.

## Adjustment

### Adjustment of Brake

### Caution

If the brake wire is cut, the machine will be unable to stop.  
If the brake wire is cracked or damaged, replace it with a new one immediately.

### Caution

If the brake is not sufficiently effective when it has been applied, adjust the brake wire.

1. Adjust the brake by use of the brake wire adjusting nut.

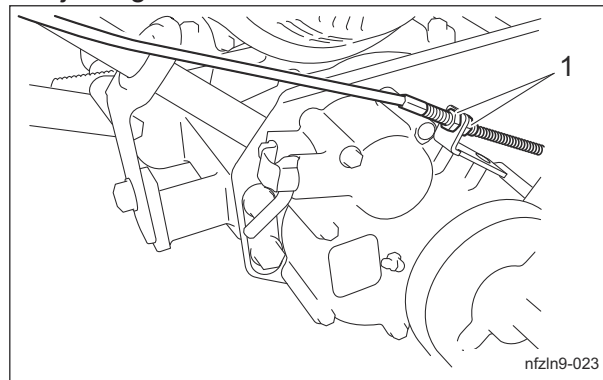

Adjustment of Brake\_001

1	Adjusting nut
---	---------------

2. Follow the same steps to adjust the belts on the brake on the opposite side.

### Caution

It may result in an unexpected accident if the left and right brakes are not equally effective.

3. Make sure that the left and right brakes are equally effective.
4. Make sure that the brake shoe does not touch the brake drum.  
Avoid the brake always being engaged.

#### Note:

The brake shoe may touch the brake drum if you hear a rubbing sound or the drum feels heavy when rotating the drum.

### Adjustment of Engine Clutch Section

For centering adjustment of the engine clutch :  
Centering adjustment of the engine clutch is required after replacement of the engine or clutch parts.

1. Adjust the engine clutch.
2. Adjust the clutch wire.
3. Adjust the clutch spring.

For clearance adjustment of the engine clutch :  
Clearance adjustment of the engine clutch is required after replacement of the clutch wire or when the clutch slips.

1. Adjust the clutch wire.
2. Adjust the clutch spring.

### Adjustment of Engine Clutch

Adjust the clearance between the engine clutch and clutch facing so that it will be 0.5 - 1.0 mm (0.020 - 0.039 in) when the main clutch lever set to the "ON" position.

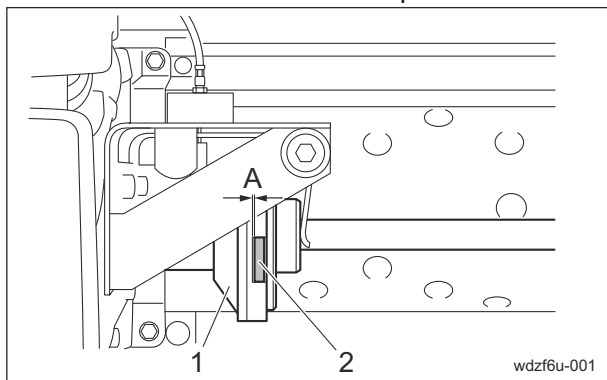

Adjustment of Engine Clutch\_001

1	Engine clutch
2	Clutch facing
A	0.5 - 1.0 mm (0.020 - 0.039 in)

1. Loosen the four bolts A securing the engine.  
Be sure not to loosen the bolts B.
2. Insert a thickness gauge (accessory tool) between the engine clutch and the clutch facing.  
Make adjustment of the engine position so that the front and rear clearances will be the same distance, and then tighten the bolts A.

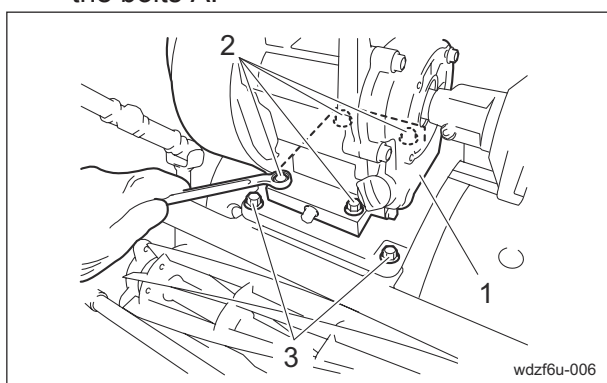

Adjustment of Engine Clutch\_002

1	Engine
2	Bolt A
3	Bolt B

### Adjustment of Clutch Wire

**Important**

Make sure that the wire is not cracked or damaged.  
If the wire is cracked or damaged, replace it with a new one immediately.

**Important**

Due to frequent use, movement of the lever will become dull, play of the inner wire will change and the inner wire will be stretched depending on R angle of the outer wire. Inspect them and, if necessary, implement adjustment.

Make adjustment of the clutch wire so that the operation distance of the clutch plate between "ON" and "OFF" positions of the main clutch lever will be 1 - 2 mm (0.039 - 0.079 in).

1. Loosen the clutch wire adjusting nuts.
2. Adjust the operation distance of the clutch plate by changing the clutch wire position.
3. After appropriate adjustment of the operation distance of the clutch plate completed, tighten the clutch wire adjusting nuts.

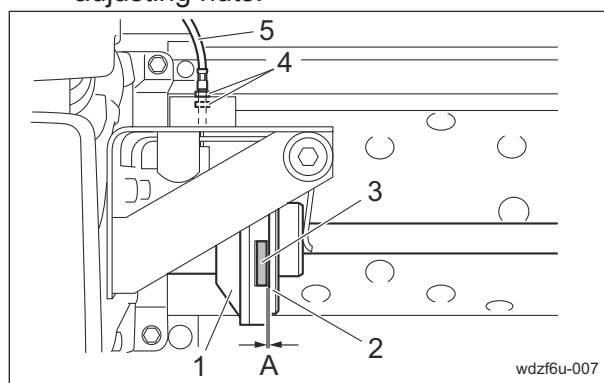

Adjustment of Clutch Wire\_001

1	Engine clutch
2	Clutch plate
3	Clutch facing
4	Clutch wire adjusting nut
5	Clutch wire
A	1 - 2 mm (0.039 - 0.079 in)

## Adjustment of Clutch Spring

The factory default setting of the clutch spring total length is approximately 63 mm (2.48 in).

The longer the spring is set, the lighter clutch handling is provided. The shorter, the heavier.

1. Make adjustment with the spring adjustment nut so that the total length of the clutch spring will be approximately 63 mm (2.48 in) when the main clutch lever set to the "ON" position.
2. Loosen the lock nut and adjust the clutch spring total length with the spring adjustment nut.
3. Confirm that there is no engine clutch slipping when the main clutch lever set to the "ON" position.
4. Tighten the lock nut.

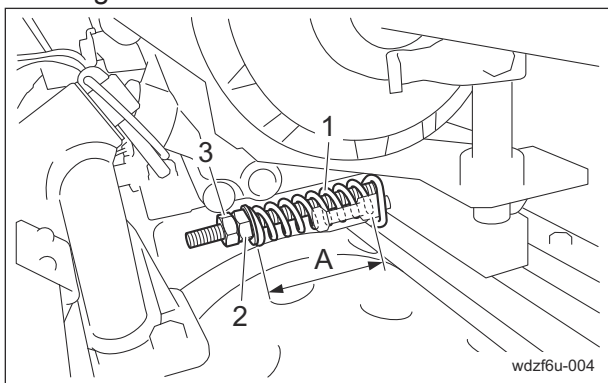

Adjustment of Clutch Spring\_001

1	Clutch spring
2	Spring adjustment nut
3	Lock nut
A	63 mm (2.48 in)

# Appended Table

---

**Tightening Torques .....Page 8-2**

- Standard Tightening Torques .....Page 8-2
- Principal Tightening Torques ..... Page 8-4

**Daily Check List ..... Page 8-5**

**Maintenance Schedule ..... Page 8-6**

**List of Adjusted Values ..... Page 8-8**

**Troubleshooting Procedures of  
Aftercut Appearance ..... Page 8-9**

- Scalping .....Page 8-9
- Angled Mismatch ..... Page 8-9
- Overlap Marks ..... Page 8-10
- Blade Does Not Cut ..... Page 8-11
- Uneven Blade Engagement .....Page 8-12

Appended Table

# Appended Table

---

## Tightening Torques

### Important

Refer to the Tightening Torque table.  
Note that the Baroness product warranty may not apply to defects caused by incorrect or overtorque tightening, etc.

## Standard Tightening Torques

### Bolts and Nuts



### Important

A number of bolts are used in each part of this machine.  
Be sure to re-tighten the bolts and nuts, because they may be loosened at the earlier stage of the use.

- As to the bolts and nuts without any special instruction, tighten them in appropriate tightening torque with proper tool.  
Too much tightening may cause the looseness or damage of the screw.
- The strength of tightening is determined by types of screws, strength, the friction of thread face or base face and others.  
The table below is for the galvanized or parkerized bolts.  
In case that the strength of internal thread is weak, it is not applied.
- Do not use rusty or sand attached "screw."  
Otherwise, it may cause insufficient tightening even if you apply the specified tightening torque.  
The friction of the screw face becomes higher and the tightening torque is canceled out by the friction, therefore sufficient tightening cannot be applied.
- If "screw" is wet by water or oil, do not tighten it with normal tightening torque.  
If the screw is wet, the torque coefficient will get smaller and it may result in too much tightening.  
Too much tightening may cause looseness by the screw stretched or result in damage.
- Do not use a bolt experienced too much burden.
- Using the impact wrench requires the skill.  
Do exercise as much as possible for steady tightening.

# Appended Table

Nominal diameter	General bolt		
	Strength classification 4.8		
	 tib3yb-001		
	N-m	kgf-cm	lb-in
M5	3 - 5	30.59 - 50.99	26.55 - 44.26
M6	7 - 9	71.38 - 91.77	61.96 - 79.66
M8	14 - 19	142.76 - 193.74	123.91 - 168.17
M10	29 - 38	295.71 - 387.49	256.68 - 336.34
M12	52 - 67	530.24 - 683.20	460.25 - 593.02
M14	70 - 94	713.79 - 958.52	619.57 - 831.99
M16	88 - 112	897.34 - 1142.06	778.89 - 991.31
M18	116 - 144	1,182.85 - 1,468.37	1,026.72 - 1,274.54
M20	147 - 183	1,498.96 - 1,866.05	1,301.10 - 1,619.73
M22	295	3,008.12	2,611.05
M24	370	3,772.89	3,274.87
M27	550	5,608.35	4,868.05
M30	740	7,545.78	6,549.74

Nominal diameter	Heat-treated bolt					
	Strength classification 8.8			Strength classification 10.9		
	 tib3yb-002			 tib3yb-003		
	N-m	kgf-cm	lb-in	N-m	kgf-cm	lb-in
M5	5 - 7	50.99 - 71.38	44.26 - 61.96	7 - 10	71.38 - 101.97	61.96 - 88.51
M6	8 - 11	81.58 - 112.17	70.81 - 97.36	14 - 18	142.76 - 183.55	123.91 - 159.32
M8	23 - 29	234.53 - 295.71	203.57 - 256.68	28 - 38	285.52 - 387.49	247.83 - 336.34
M10	45 - 57	458.87 - 581.23	398.30 - 504.51	58 - 76	591.43 - 774.97	513.36 - 672.68
M12	67 - 85	683.20 - 866.75	593.02 - 752.34	104 - 134	1,060.49 - 1,366.40	920.50 - 1186.03
M14	106 - 134	1,080.88 - 1,366.40	938.21 - 1,186.03	140 - 188	1,427.58 - 1,917.04	1,239.14 - 1,663.99
M16	152 - 188	1,549.94 - 1,917.04	1,345.35 - 1,663.99	210 - 260	2,141.37 - 2,651.22	1,858.71 - 2,301.26
M18	200 - 240	2,039.40 - 2,447.28	1,770.20 - 2,124.24	280 - 340	2,855.16 - 3,466.98	2,478.28 - 3,009.34
M20	245 - 295	2,498.27 - 3,008.12	2,168.50 - 2,611.05	370 - 450	3,772.89 - 4,588.65	3,274.87 - 3,982.95
M22	-	-	-	530	5,404.41	4,691.03
M24	-	-	-	670	6,831.99	5,930.17
M27	-	-	-	1,000	10,197.00	8,851.00
M30	-	-	-	1,340	13,663.98	11,860.34

**Note:**  
The same values are applied to "fine screw thread."

# Appended Table

## Principal Tightening Torques

### Tightening Torque by Model

#### LM101

Tighten the following bolts and nuts at the torque specified in the table.

For thread locking adhesive, apply a middle strength thread locker (ThreeBond 1322 or equivalent anaerobic sealant).

Location		Code	Part name	Tightening torque			Thread locking adhesive
				N-m	kgf-cm	lb-in	
Mower	Reel shaft	K0170000082	NUT, SMALL P1.5 M20-8	36	367.09	318.64	-
	Reel shaft (with groomer)	LM101--1205Z0	GEAR, REEL 20-TEETH A	36	367.09	318.64	-
	Front roller	LM54G--0132Z0	BOLT, SUS MOUNTING MOWER (LH)	29 - 38	295.71 - 387.49	256.68 - 336.34	-
		LM54G--0133Z0	BOLT, SUS MOUNTING MOWER (RH)	29 - 38	295.71 - 387.49	256.68 - 336.34	-
	Bed knife	K0071000222	SCREW, HT + FLAT HEAD M6-12	7 - 9	71.38 - 91.77	61.96 - 79.66	-
Wheel	K001A080201	BOLT, 13T W/HEX HOLE M8-20	14 - 19	142.76 - 193.74	123.91 - 168.17	-	
Handle	K0010100252	BOLT, HT M10-25	29 - 38	295.71 - 387.49	256.68 - 336.34	-	
Groomer	K6809000270	SCREW	18	183.55	159.32	-	
	K0160000602	NUT, SPECIAL P1 M17 W/M4	5 - 10	50.99 - 101.97	44.26 - 88.51	-	
	K6083000143	PIN, STEPPED FOR FIXING (RH) CASE	6	61.18	53.11	-	
	LM54GAS1230Z3	BOLT, CLAMPING CASE (LH)	6	61.18	53.11	-	

## Daily Check List

LM101

- . . . Inspect, adjust, supply, clean (first time)
- . . . Inspect, adjust, supply, clean
- ▲ . . . Replace (first time)
- △ . . . Replace

Maintenance Item		Before Work	After Work	Remarks
Engine (Honda)	*1	Check engine oil	○	
	*1	Check fuel	○	
		Check fuel strainer	○	
		Check oil or water leaks	○	
	*1	Check air cleaner	○	
		Check bolts and nuts	○	
		Check engine area	○	
	Clean engine area		○	
Driving section		Check tire	○	
		Check machine exterior	○	
		Check bolts and nuts	○	
		Check main clutch lever	○	
		Check clutch lock lever	○	
		Check cover	○	
		Check brake	○	
		Check wire	○	
		Check light	○	
		Clean machine exterior		○
Cutting section		Check reel cutter and bed knife	○	
		Check cover	○	
		Check roller	○	
		Check drum	○	
		Check groomer	○	
		Check grass catcher	○	
		Check cutting section	○	
		Check bolts and nuts	○	
	Clean cutting section		○	

· \*1: Refer to the Engine's Owner's Manual.

# Appended Table

## Maintenance Schedule

LM101

● . . . Inspect, adjust, supply, clean (first time)

○ . . . Inspect, adjust, supply, clean

▲ . . . Replace (first time)

△ . . . Replace

Maintenance Item		Before Work	After Work	Every 10 hrs.	Every 25 hrs.	Every 50 hrs.	Every 100 hrs.	Every 300 hrs.	Every 500 hrs.	Every year	Every 2 years	When Required	Remarks
Engine	*2	Check spark plug					○						
	*2	Clean air cleaner element					○						Air cleaner should be cleaned more often in dusty conditions than in normal conditions
	*2	Clean spark arrester					○						
	*2	Clean sediment cup					○						
	*1	Clean fuel tank & filter					○						
	*1	Check idling speed						○		○			Every 300 hours or every year whichever comes earlier
	*1	Check valve clearance						○		○			Every 300 hours or every year whichever comes earlier
	*1	Remove carbon in combustion chamber							○				
	*1	Check fuel hoses and clamp bands									○		
	*2	Replace engine oil				▲		△					
	*2	Replace air cleaner element							△		△		Paper filter element: Every 300 hours or every year whichever comes earlier Foam filter element: As necessary
	*2	Replace spark plug							△		△		Every 300 hours or every year whichever comes earlier
*1	Replace fuel hoses and clamp bands											△	
Driving section		Check electrical wiring				○	○						
		Grease and Lubricate			○	○							Maintenance schedules differ according to greasing points
		Adjust engine clutch spring										○	
		Adjust engine clutch clearance										○	
	*1	Replace bearings inside gearcase									△		

# Appended Table

Maintenance Item		Before Work	After Work	Every 10 hrs.	Every 25 hrs.	Every 50 hrs.	Every 100 hrs.	Every 300 hrs.	Every 500 hrs.	Every year	Every 2 years	When Required	Remarks
Driving section	*1	Replace oil seals inside gearcase								△			
	*1	Replace grease inside gearcase								△			
		Replace brake wire										△	
		Replace throttle wire										△	
		Replace main clutch wire										△	
Cutting section		Check blade engagement	○										
		Check mowing height	○										
		Check groomer height	○										
		Grease		○	○								Maintenance schedules differ according to greasing points
		Clean and grease bedknife eccentric bushes							○	○			Every 500 hours or every year whichever comes earlier, and when replacing a bedknife additionally.
		Backlap blades										○	
		Engage blades										○	
		Adjust mowing height										○	
		Adjust groomer										○	
		Adjust cutter adjustment spring										○	
		Regrind reel cutter										○	Grind/Replace blades as and when required
	*1	Replace bearings inside gearcase									△		
	*1	Replace front/rear roller bearings									△		
	*1	Replace grass catcher roller bearings									△		
	*1	Replace oil seals inside gearcase									△		
*1	Replace front/rear roller oil seals									△			
*1	Replace grass catcher roller oil seals									△			
*1	Replace grease inside gearcase									△			

Appended Table

- \*1: Consult your local Baroness Dealer for this service.
- \*2: Refer to the Engine's Owner's Manual.
- The values for consumables are not guaranteed.

# Appended Table

---

## List of Adjusted Values

Cutter adjustment spring	43 mm (1.69 in)	Total length of spring
Reel cutter shaft bearing preload spring	11.5 mm (0.453 in)	Total length of spring
Reel cutter rotation torque	0.8 - 1.0 N · m (8 - 10 kgf · cm)	
Engine clutch	0.5 - 1.0 mm (0.020 - 0.039 in)	Clearance between engine clutch and clutch facing
Operation distance of clutch plate	1 - 2 mm (0.039 - 0.079 in)	
Engine clutch spring	63 mm (2.48 in)	Total length of spring

## Troubleshooting Procedures of Aftercut Appearance

### Scalping

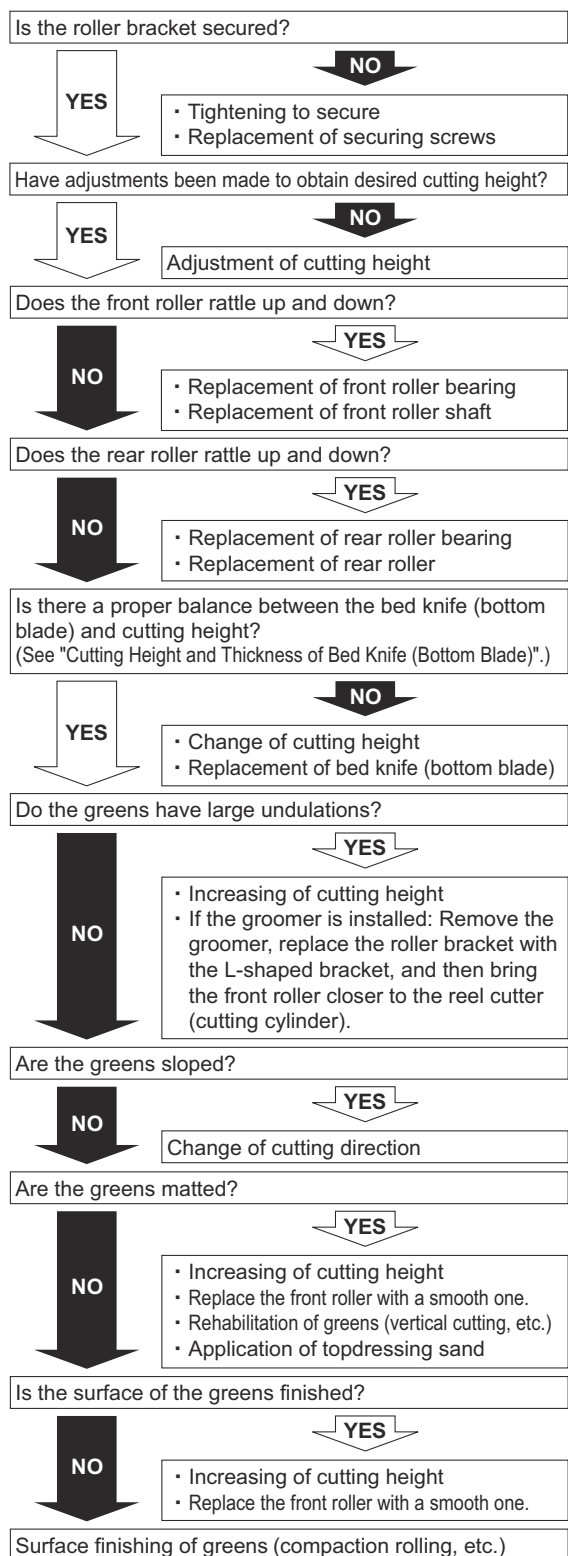

iiwt3m-007E

Scalping\_001

### Angled Mismatch

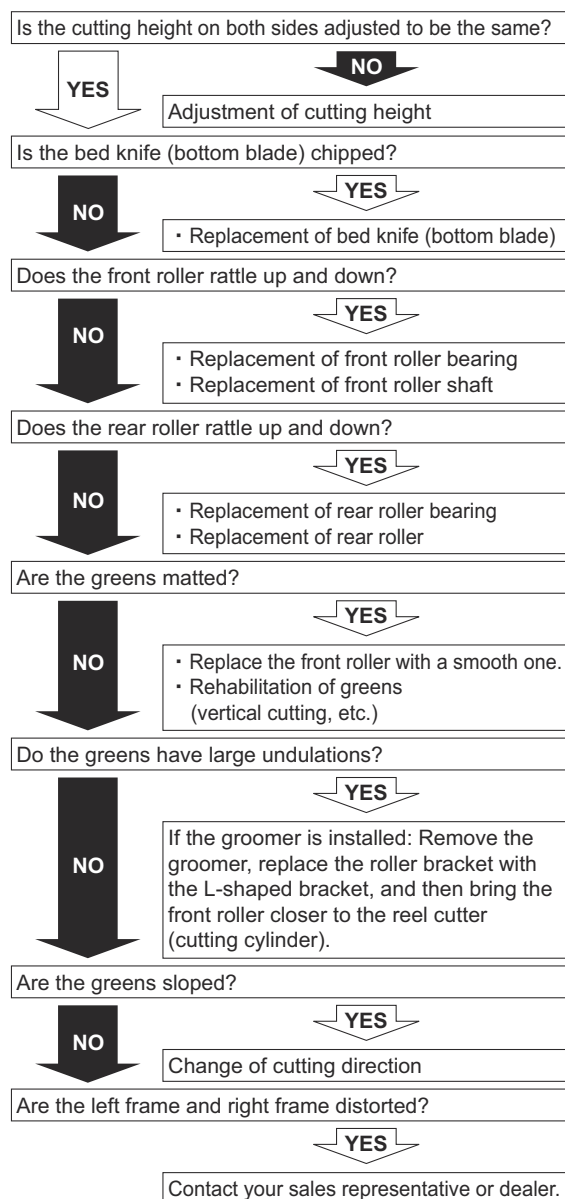

7x9s4e-004E

Angled Mismatch\_001

# Appended Table

## Overlap Marks

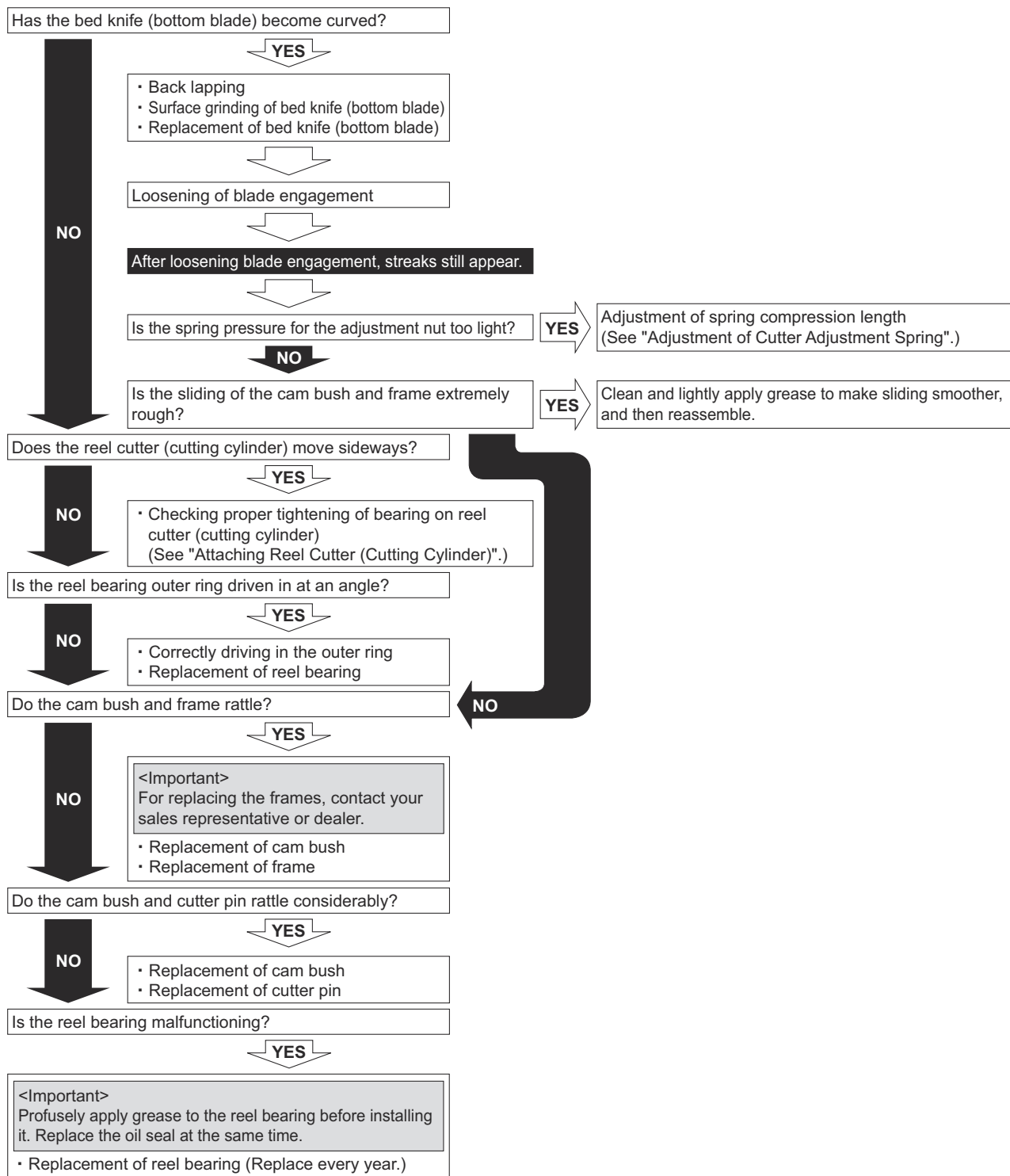

## Blade Does Not Cut

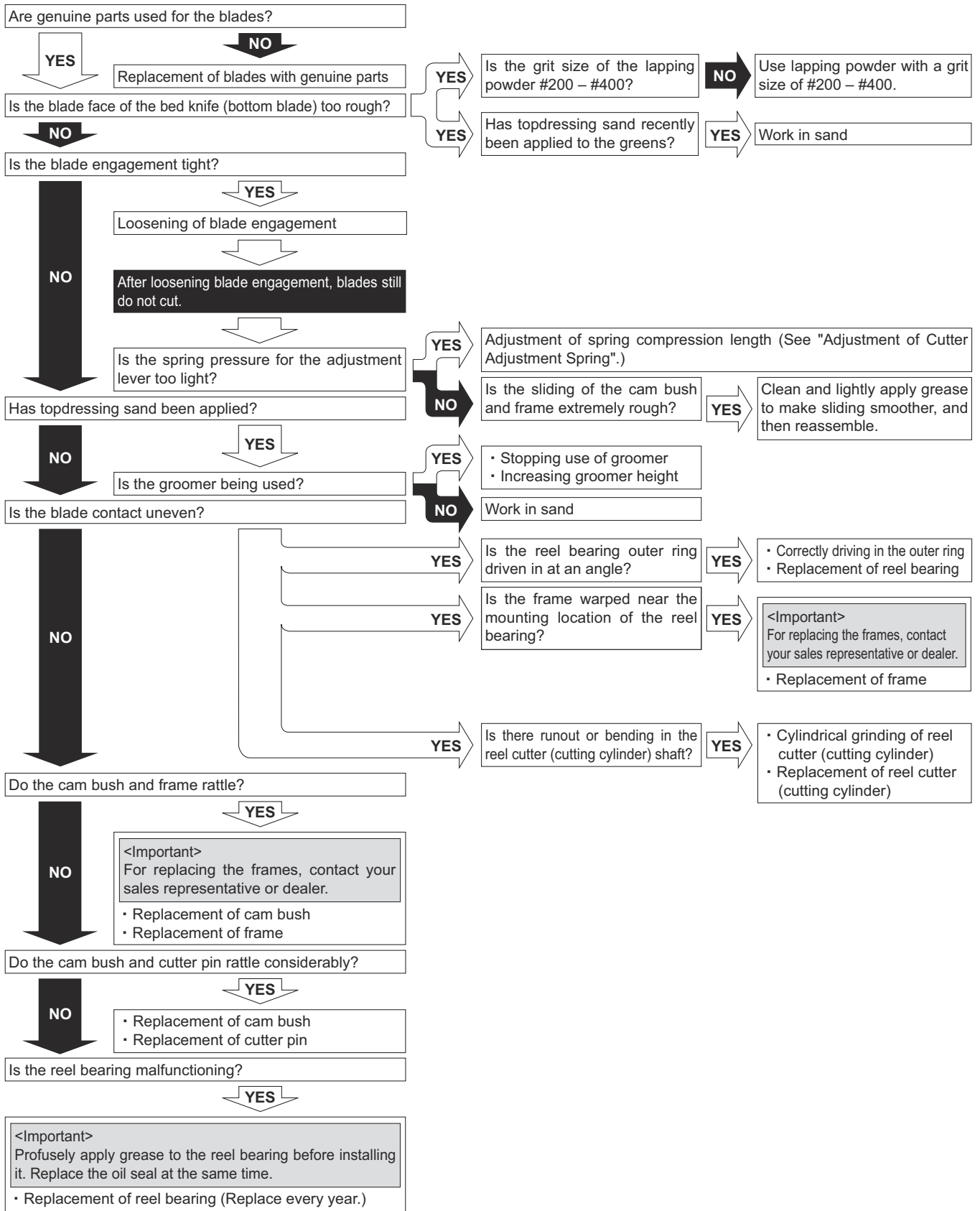

Appended Table

# Appended Table

---

## Uneven Blade Engagement

The unevenness is a difference of tightening torque between the left and right cutter adjustment nuts, or blade engagement on only one side, which cannot be adjusted.

Promptly resolve the issue in order to maintain the optimum performance of the machine.

Cause of unevenness	Measure to resolve
Asymmetrical wear of reel cutter (cutting cylinder)	Cylindrical grinding of reel cutter (cutting cylinder) Replacement of reel cutter (cutting cylinder)
Asymmetrical wear of bed knife (bottom blade)	Surface grinding of bed knife (bottom blade) Replacement of bed knife (bottom blade)
Distortion of frames	Rearrange frames in parallel

### Important

Depending on the extent of the symptoms, they may not be resolved.

### Important

Performing temporary measures may cause the symptoms to progress, resulting in cutting issues.

Temporary measures:

- Adjustment with cam bushes  
"Adjustment of CAM" (Page 6-18)
- Adjustment of spring pressure  
"Adjustment of Cutter Adjustment Spring" (Page 6-18)

**Daily Check Records ..... Page 9-2**

**Maintenance Records .....Page 9-5**



Records

# Records

## Daily Check Records

LM101

Use this table freely for your records of the daily check.

Model								Serial Number			
Items											
Engine (Honda)	Check engine oil										
	Check fuel										
	Check fuel strainer										
	Check oil or water leaks										
	Check air cleaner										
	Check bolts and nuts										
	Check engine area										
	Clean engine area										
Driving section	Check tire										
	Check machine exterior										
	Check bolts and nuts										
	Check main clutch lever										

Items										
Driving section	Check clutch lock lever									
	Check cover									
	Check brake									
	Check wire									
	Check light									
	Clean machine exterior									
Cutting section	Check reel cutter and bed knife									
	Check cover									
	Check roller									
	Check drum									
	Check groomer									
	Check grass catcher									
	Check cutting section									
	Check bolts and nuts									

Records

# Records

---

Items											
Cutting section	Clean cutting section										

**Maintenance Records**

LM101  
Use this table freely for your records of the maintenance.

Model		Serial Number	
Items			
Engine	Check spark plug		
	Clean air cleaner element		
	Clean spark arrester		
	Clean sediment cup		
	Clean fuel tank & filter		
	Check idling speed		
	Check valve clearance		
	Remove carbon in combustion chamber		
	Check fuel hoses and clamp bands		
	Replace engine oil		
	Replace air cleaner element		
	Replace spark plug		

Records

# Records

Items											
Engine	Replace fuel hoses and clamp bands										
Driving section	Check electrical wiring										
	Grease and Lubricate										
	Adjust engine clutch spring										
	Adjust engine clutch clearance										
	Replace bearings inside gearcase										
	Replace oil seals inside gearcase										
	Replace grease inside gearcase										
	Replace brake wire										
	Replace throttle wire										
	Replace main clutch wire										
Cutting section	Check blade engagement										
	Check mowing height										
	Check groomer height										

Items											
Cutting section	Grease										
	Clean and grease bedknife eccentric bushes										
	Backlap blades										
	Engage blades										
	Adjust mowing height										
	Adjust groomer										
	Adjust cutter adjustment spring										
	Regrind reel cutter										
	Replace bearings inside gearcase										
	Replace front/rear roller bearings										
	Replace grass catcher roller bearings										
	Replace oil seals inside gearcase										
	Replace front/rear roller oil seals										
	Replace grass catcher roller oil seals										

Records

# Records

---

Items											
Cutting section	Replace grease inside gearcase										

**BARONESS**<sup>®</sup>  
Quality on Demand

 **KYOEISHA CO., LTD.**  
Head Office 1-26, Miyuki-cho, Toyokawa-city, Tel :+81-533-84-1390  
Aichi-pref, 442-8530 JAPAN Fax:+81-533-84-1220