

TDA1200 · TDA1600

Tractor Mounted Aerator

Owner's Operating Manual

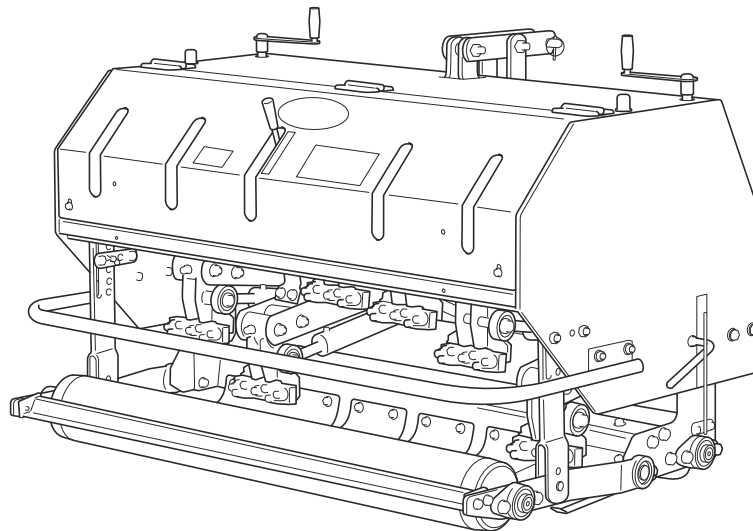

Serial No. TDA1200: 21038- · TDA1600: 21026-

"Required reading"
Read this manual before using the machine.

BARONESS[®]
Quality on Demand

Original Instructions Ver.3.2

Regulations

EU Regulations

(For EU)

This product complies with all relevant EU Regulations.

For more information, please refer to the Declaration of Conformity attached.

Thank you for purchasing the Baroness product. This manual describes the proper handling, adjustment, and inspection of your product. We hope you will use the product safely, and take advantage of its best performance.

QR Code

(*QR Code is a registered trademark of DENSO WAVE INCORPORATED.)

A QR code label is affixed on the machine.

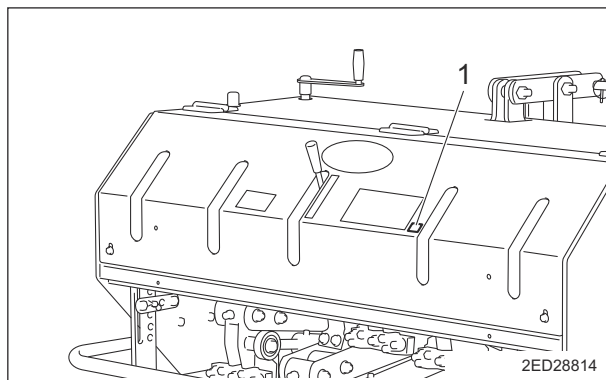

QR Code_001

1	QR code label
---	---------------

Scan the QR code with your smartphone for easy access to Baroness Manual Reference Service where you can browse Owner's Operating Manual and Parts Catalog.
TDA1200: <https://doc.baroness-international.com/manuals/TDA1200>



QR Code_002

TDA1600: <https://doc.baroness-international.com/manuals/TDA1600>



QR Code_003

Introduction

Read this manual carefully to ensure that you thoroughly understand how to properly operate and maintain the product, and to avoid causing injury to yourself or others.

The operator is responsible for operating the product properly and safely.

Maintenance service for this machine should be performed by a mechanic with expertise.

If you have any questions concerning maintenance or genuine parts, please contact a Baroness dealer or Kyoisha.

When making inquiries about your product, please specify the model and serial number.

When loaning or transferring the product, please also provide this manual together with the product.

Kyoeisha Co., Ltd.

Warning Symbols

This manual uses the following warning symbols for handling precautions that are important for your safety.

 <small>696cq5-001</small>	Warning symbol
--	----------------

This symbol indicates the articles regarding “Danger,” “Warning,” or “Caution.”

Those articles describe important safety precautions and so read them carefully to understand completely before operating the machine.

Failure to adequately follow these safety precautions may cause an accident.

Danger

This symbol indicates that serious injury or death will occur if the warning is ignored.

Warning

This symbol indicates that serious injury or death may occur if the warning is ignored.

Caution

This symbol indicates that injury or damage to property may occur if the warning is ignored.

Important

This symbol indicates precautions on the mechanism of the machine.

Precautionary Statement

 **Caution**

The information described in this manual is subject to change for improvement without prior notice.

When replacing parts, be sure to use genuine Baroness parts or parts designated by Kyoisha.

Note that the Baroness product warranty may not apply to defects caused by the use of parts from other companies.

Prior to use, carefully read the following manuals to thoroughly understand the contents for safe and correct operation.

- Baroness Owner's Operating Manual
- The Tractor's Owner's Manual
- The Universal Joint (Drive Shaft) Owner's Manual

Purpose

This product is intended for aerating golf courses.

Do not use this product in any way other than its intended purpose, and do not modify this product.

Operating this product for other purposes and modifying it may be very dangerous and may cause damage to the product.

TDA1200 · TDA1600

Introduction

Safety	Page 1-1	Maintenance Records	Page 8-3
Safe Operating Practices	Page 1-2		
Disposal	Page 2-1		
Recycle and Waste Disposal	Page 2-2		
Product Overview	Page 3-1		
Specifications	Page 3-2		
Names of Each Section	Page 3-10		
Regulation Decals	Page 3-11		
Safety Signs and Instruction Signs	Page 3-13		
Operation Decals	Page 3-15		
Description of Functions	Page 4-1		
Change Lever	Page 4-2		
Up-Down Handle	Page 4-2		
Rear Roller	Page 4-3		
Handling Instructions	Page 5-1		
Preparation for Installation	Page 5-2		
Installation	Page 5-2		
Inspection before Use	Page 5-6		
Move	Page 5-8		
Operations	Page 5-8		
Transporting	Page 5-11		
Cleaning after Use	Page 5-11		
Storage	Page 5-11		
Maintenance	Page 6-1		
Precautions for Maintenance	Page 6-2		
Supplying Fluids	Page 6-2		
Greasing	Page 6-2		
Adjustment	Page 6-5		
Replacement	Page 6-6		
Storage	Page 6-7		
Appended Table	Page 7-1		
Tightening Torques	Page 7-2		
Daily Check List	Page 7-7		
Maintenance Schedule	Page 7-8		
Crank Timing Diagram	Page 7-8		
Crank Timing Diagram	Page 7-9		
Records	Page 8-1		
Daily Check Records	Page 8-2		

Contents

Safe Operating Practices Page 1-2

Training Page 1-2

Preparation Page 1-2

Operation Page 1-2

Maintenance Page 1-3

TowingPage 1-3

Safety

Failure to adequately follow these safety precautions may cause an accident resulting in injury or death.

Danger

This product is designed to ensure safe operation and has been tested and inspected thoroughly before shipment from the factory. The product is equipped with safety devices to prevent accidents.

However, whether the product demonstrates its original performance level depends on the manner in which it is operated and handled, as well as the manner in which it is managed on a daily basis.

Inappropriate use or management of the product may result in injury or death.

Observe the following safety instructions to ensure safe operation.

Safe Operating Practices

Training

1. Read this manual and other training material carefully.
Be familiar with the controls, safety signs, and the proper use of the equipment.
2. If the operator or mechanic can not read the language used in this manual, it is the owner's responsibility to explain this material to them.
3. All operators and mechanics should seek and obtain professional and practical instruction.
The owner is responsible for training the users.
4. Never allow people unfamiliar with these instructions to use or service the machine.
5. The owner/user can prevent and is responsible for accidents or injuries occurring to themselves, other people, or property.
6. Keep in mind that the owner, operator, and mechanic are responsible for accidents or hazards occurring to other people or their property.
7. You can find additional safety information where needed throughout this manual.
8. Determine the left and right sides of the machine from the normal operating position.

Preparation

1. Evaluate the terrain to determine what accessories and attachments are needed to properly and safely perform the job.
Only use accessories and attachments approved by the manufacturer.
2. While operating, always wear substantial footwear, long trousers, hard hat, safety glasses, mask, and ear protection.
Long hair, loose clothing, or jewelry may get tangled in moving parts.
Do not operate the equipment when barefoot or wearing open sandals.
3. Inspect the area where the equipment is to be used and remove all objects such as rocks, toys and wire which can be thrown by the machine.
4. Keep children out of the operating area and under the watchful care of a responsible adult other than the operator.
5. Check that shields are attached properly.
6. Before using, always visually inspect to see that the tines and tine mounts are not worn or damaged and that the tines are normally mounted.
When some tines are worn or damaged, replace all the installed tines at the same time to prevent abnormal vibration.
7. Pay attention to all the tine mount holders, which operate simultaneously.

Operation

1. Never operate the machine with damaged guards, shields, or without safety protective devices in place.
2. Keep hands and feet away from the rotating parts.
3. Never operate while people, especially children, or pets are nearby.
4. Only operate in good light, keeping away from holes and hidden hazards.
5. Disengage drive to the mechanical equipment section, when other than operating.
6. Stop the engine in the following conditions.
 - [1] Before making height or depth adjustment unless adjustment can be made from the operator's position.
 - [2] Before clearing blockages.

- [3] Before checking, cleaning or working on the machine.
 - [4] After striking a foreign object or if an abnormal vibration occurs.
Inspect the machine for damage and make repairs before restarting and operating the equipment.
7. Take care when loading or unloading the machine into a trailer or a truck.
Load or unload the machine in a flat and safe place.
Before loading or unloading, set the parking brake on the truck or trailer, stop the engine, and chock the wheels.
Fasten the machine to the truck with a rope or other suitable restraining device that has sufficient strength.

Maintenance

1. Never allow untrained personnel to service machine.
2. Implement the following work before adjusting, cleaning or repairing.
 - [1] Stop the machine on level ground.
 - [2] Disengage drive to the mechanical equipment section.
 - [3] Set the parking brake.
 - [4] Stop the engine.
 - [5] Wait for all movement to stop.
3. Appropriately manage and correctly use the tools necessary for servicing or adjusting the machine.
4. Keep hands and feet away from moving parts.
If possible, do not make adjustments with the engine running.
5. Keep all parts in good working condition and all hardware tightened.
Replace all worn or damaged decals.
6. Keep all nuts, bolts and screws tight to be sure the equipment is in safe working condition.
7. Carefully release pressure from components with stored energy.
8. Use care when checking the tines.
Wrap the tines or wear gloves, and use caution when servicing them.
Only replace tines.
Never straighten or weld them.
9. Pay attention to all the tine mount holders, which operate simultaneously.

Towing

1. Follow the manufacturer's recommendation for weight limits for towed equipment and towing on slopes.

Safety

Recycle and Waste Disposal Page 2-2

About RecyclePage 2-2

About Waste Disposal Page 2-2

Disposal

Recycle and Waste Disposal

About Recycle

Recycling battery etc. is recommended for environmental conservation and economical use of resources.

It may be required by local laws.

About Waste Disposal

Make sure that waste generated when servicing or repairing the machine is disposed of in accordance with local regulations. (e.g. waste oil, antifreeze, rubber products, and wires etc.)

Specifications Page 3-2

Specifications List Page 3-2

Types of Tines Page 3-4

Relationship between Operation

Speed and Pitch (TDA1200) Page 3-7

Relationship between Operation

Speed and Pitch (TDA1600) Page 3-8

Names of Each Section Page 3-10**Regulation Decals Page 3-11**

Positions of Regulation Decals Page 3-11

Description of Regulation Decals Page 3-11

Safety Signs and Instruction Signs ... Page 3-13

About Safety Signs and Instruction

Signs Page 3-13

Positions of Safety Decals and

Instruction Decals Page 3-13

Description of Safety Decals and

Instruction Decals Page 3-13

Operation Decals Page 3-15

Positions of Operation Decals Page 3-15

Description of Operation Decals Page 3-15

Product Overview

Specifications

Specifications List

TDA1200

Model		TDA1200	
Name		Tractor Mounted Aerator	
Dimensions	Total length	97 cm	38.19 in
	Total width	142 cm	55.91 in
	Total height	85 cm	33.46 in
Weight	Including lifting strut (mount)	525 kg	1,157.41 lb
Gear oil capacity		3.8 dm ³ (3.8 L)	1.0 U.S.gals
Number of cranks		6	
Type of tine		φ17 • 215 mm	φ17 • 8.46 in
Number of tines		18 pcs (Various options available)	
Operating width		117 cm	46.06 in
Pitch		Depending on the condition	
Distance between tines		6.5 • 10 cm	2.56/3.94 in
Aeration depth		Max. 25 cm (Depending on the conditions)	Max. 9.84 in (Depending on the condition)
Drive	Aerating	PTO driving	
Speed of PTO rotation		Max. 400 rpm	
Working speed		-	
Efficiency		1,872 m ² /h (1.6 km/h x Operating width)	0.46 acres/hour (0.99 mph x Operating width)
Applicable tractor	Horsepower	13.2 kW (18.0 PS) or more	
	Max lifting capacity	650 kg or more	1,432.98 lb or more
Universal joint	Clutch setting torque	Allowed max 520 N-m (5,302.44 kgf-cm)	Allowed max 4,602.52 lb-in
		Regular use 280 N-m (2,855.16 kgf-cm)	Regular use 2,478.28 lb-in
Connection		Tractor; 3-point link lifting type	

Product Overview

TDA1600

Model		TDA1600	
Name		Tractor Mounted Aerator	
Dimensions	Total length	97 cm	38.19 in
	Total width	179 cm	70.47 in
	Total height	85 cm	33.46 in
Weight	Including lifting strut (mount)	580 kg	1,278.66 lb
Gear oil capacity		3.8 dm ³ (3.8 L)	1.0 U.S.gals
Number of cranks		8	
Type of tine		φ17 • 215 mm	φ17 • 8.46 in
Number of tines		24 pcs (Various options available)	
Operating width		156 cm	61.42 in
Pitch		Depending on the condition	
Distance between tines		6.5 • 10 cm	2.56/3.94 in
Aeration depth		Max. 18 cm (Depending on the conditions)	Max. 7.09 in (Depending on the conditions)
Drive	Aerating	PTO driving	
Speed of PTO rotation		Max. 1,000 rpm	
Working speed		-	
Efficiency		3,120 m ² /h (2.0 km/h x Operating width)	0.77 acres/hour (1.24 mph x Operating width)
Applicable tractor	Horsepower	17.6 kW (24.0 PS) or more	
	Max lifting capacity	700 kg or more	1,543.21 lb or more
Universal joint	Clutch setting torque	Allowed max 520 N-m (5,302.44 kgf-cm)	Allowed max 4,602.52 lb-in
		Regular use 280 N-m (2,855.16 kgf-cm)	Regular use 2,478.28 lb-in
Connection		Tractor; 3-point link lifting type	

Product Overview

Types of Tines

There are two main types of tines: "Pipe type" (which pulls out the lawn) and "Spike type" (which drills holes).

	Pipe type	Spike type
Aeration effect	Large effect	Good
Permeability effect	Large effect	Good
Underground gas diffusion effect	Large effect	Good
Damage to turf surface	Large	Less than with pipe type
Damage to lawn	Large	Less than with pipe type
Lawn recovery	Takes time	Quick
Aeration period	When lawn cultivation is thriving	Whenever needed
Core disposal	Necessary	Unnecessary (Cores not discharged)
Mowing after aeration	Better to mow	Better to mow
Effect on play after aeration	Not immediately possible	Instantly possible (However, mowing after tamping is required.)
Degradation of thatch by mixing with soil	Promoted	Limited

1. Pipe-type tines

	Tip dimensions		Outer diameter of mount	Total length	Quantity used	Tine mount	Lawn pressing plate
	Inner diameter	Outer diameter					
φ10 V tine100	6 mm (0.24 in)	-	9.5 mm (0.37 in)	100 mm (3.94 in)	72 96	Specialized	Specialized
φ12 V tine120	8.2 mm (0.323 in)	-	9.5 mm (0.37 in)	120 mm (4.72 in)	72 96	Specialized	Specialized
φ13 V tine225	7 mm (0.27 in)	-	12 mm (0.47 in)	225 mm (8.46 in)	18 24	-	-
φ16 V tine125	11 mm (0.43 in)	-	16 mm (0.63 in)	125 mm (4.92 in)	36 48	Specialized	-
φ17 V tine215	10 mm (0.39 in)	-	12 mm (0.47 in)	215 mm (8.46 in)	18 24	-	-
φ17 V tine265	10 mm (0.39 in)	-	12 mm (0.47 in)	265 mm (10.43 in)	18 24	-	-

* In the column "Quantity used", the upper figure indicates the quantity for TDA1200 and the lower for TDA1600.

Product Overview

φ10 V tine100

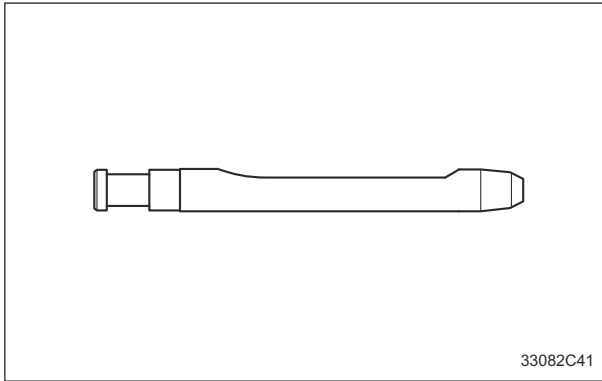

33082C41

Types of Tines_001

φ17 V tine215

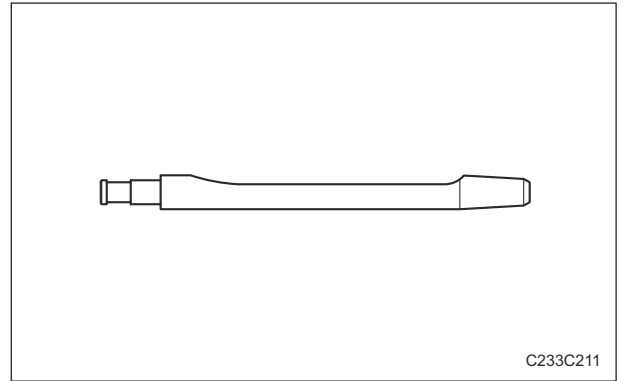

C233C211

Types of Tines_005

φ12 V tine120

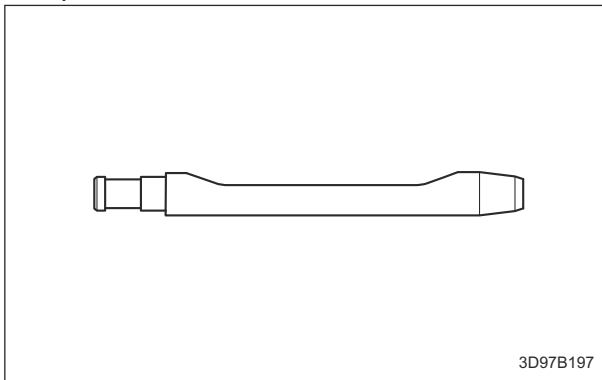

3D97B197

Types of Tines_002

φ17 V tine265

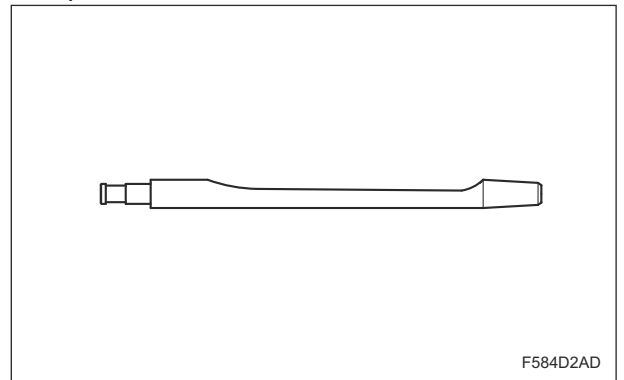

F584D2AD

Types of Tines_006

φ13 V tine225

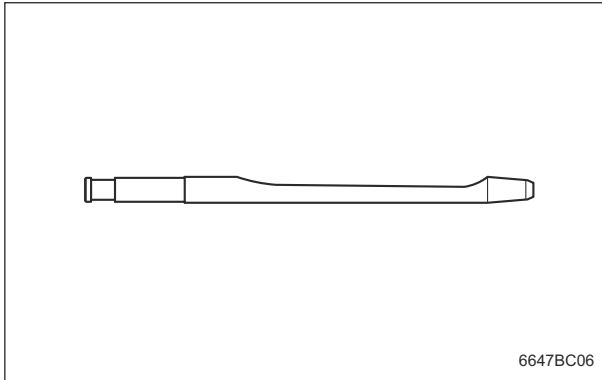

6647BC06

Types of Tines_003

φ16 V tine125

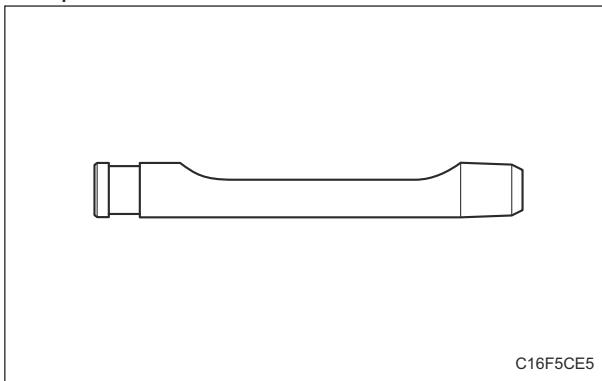

C16F5CE5

Types of Tines_004

Product Overview

2. Spike-type tines

	Tip dimensions		Outer diameter of mount	Total length	Quantity used	Tine mount	Lawn pressing plate
	Inner diameter	Outer diameter					
φ8 spike tine	-	8 mm (0.31 in)	16 mm (0.63 in)	120 mm (4.72 in)	36 48	Specialized	-
φ10 solid tine	-	10 mm (0.39 in)	9.5 mm (0.37 in)	100 mm (3.94 in)	72 96	Specialized	Specialized
φ12.5 spike tine	-	12.5mm (0.49 in)	16 mm (0.63 in)	120 mm (4.72 in)	48	Specialized	-

* In the column "Quantity used", the upper figure indicates the quantity for TDA1200 and the lower for TDA1600.

φ8 spike tine

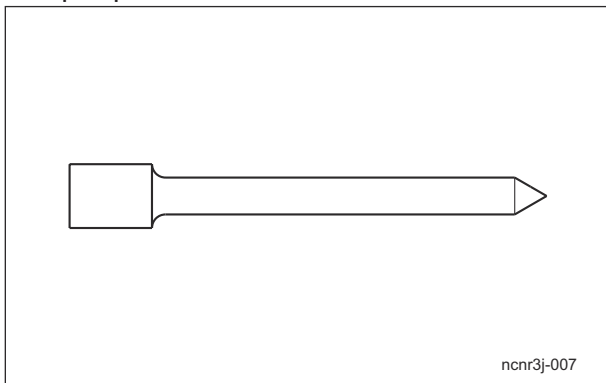

Types of Tines_007

φ10 solid tine

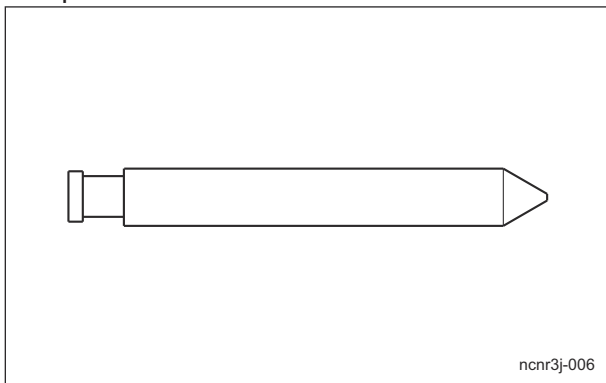

Types of Tines_008

φ12.5 spike tine

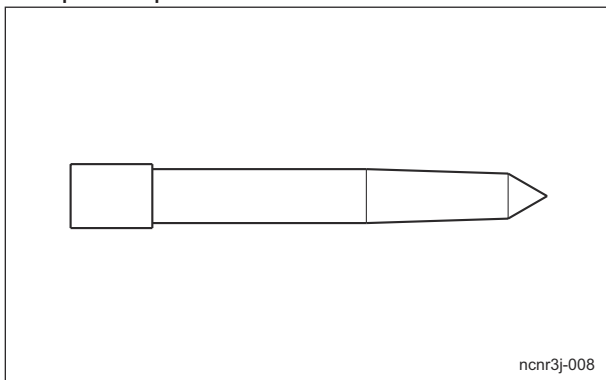

Types of Tines_009

Relationship between Operation Speed and Pitch (TDA1200)

Important

The engine rotation speed during tractor operation is 1,600 - 2,000 rpm.
PTO rotation speed is maximum 400 rpm.
Exceeding the PTO rotation speed 400 rpm may cause the damage to the machine.

Following table shows the approximation of relationship between operation speed and pitch.

Tractor's speed and the pitch change depending on the tractor's specifications.

Tractor				TDA1200	
Range shift	Main shift	Speed	PTO rotation	Crank rotation	Pitch
1	1	0.52 km/h (0.32 mph)	1st speed	Slow speed	53 mm (2.09 in)
				High speed	42 mm (1.65 in)
1	2	0.75 km/h (0.47 mph)	1st speed	Slow speed	75 mm (2.95 in)
				High speed	60 mm (2.36 in)
1	3	1.06 km/h (0.66 mph)	1st speed	Slow speed	108 mm (4.25 in)
				High speed	86 mm (3.39 in)
1	4	1.60 km/h (0.99 mph)	1st speed	Slow speed	163 mm (6.42 in)
				High speed	130 mm (5.12 in)

* The table shows the figures during the maximum engine rotation speed 1,800 rpm.

Product Overview

Relationship between Operation Speed and Pitch (TDA1600)

Important

The engine rotation speed during tractor operation is 1,800 - 2,300 rpm.
PTO rotation speed is maximum 1,000 rpm.
Exceeding the PTO rotation speed 1,000 rpm may cause the damage to the machine.

Following table shows the approximation of relationship between operation speed and pitch.

Tractor's speed and the pitch change depending on the tractor's specifications.

Tractor				TDA1600	
Range shift	Main shift	Speed	PTO rotation	Crank rotation	Pitch
1	1	0.58 km/h (0.36 mph)	1st speed	Slow speed	53 mm (2.09 in)
				High speed	42 mm (1.65 in)
			2nd speed	Slow speed	37 mm (1.46 in)
				High speed	30 mm (1.18 in)
1	2	0.83 km/h (0.52 mph)	1st speed	Slow speed	75 mm (2.95 in)
				High speed	60 mm (2.36 in)
			2nd speed	Slow speed	53 mm (2.09 in)
				High speed	42 mm (1.65 in)
1	3	1.18 km/h (0.73 mph)	1st speed	Slow speed	108 mm (4.25 in)
				High speed	86 mm (3.39 in)
			2nd speed	Slow speed	75 mm (2.95 in)
				High speed	60 mm (2.36 in)
			3rd speed	Slow speed	50 mm (1.97 in)
				High speed	40 mm (1.57 in)

Product Overview

Tractor				TDA1600	
Range shift	Main shift	Speed	PTO rotation	Crank rotation	Pitch
1	4	1.78 km/h (1.11 mph)	1st speed	Slow speed	163 mm (6.42 in)
				High speed	130 mm (5.12 in)
			2nd speed	Slow speed	114 mm (4.49 in)
				High speed	91 mm (3.58 in)
			3rd speed	Slow speed	75 mm (2.95 in)
				High speed	60 mm (2.36 in)

* The table shows the figures during the maximum engine rotation speed 2,000 rpm.

Product Overview

Names of Each Section

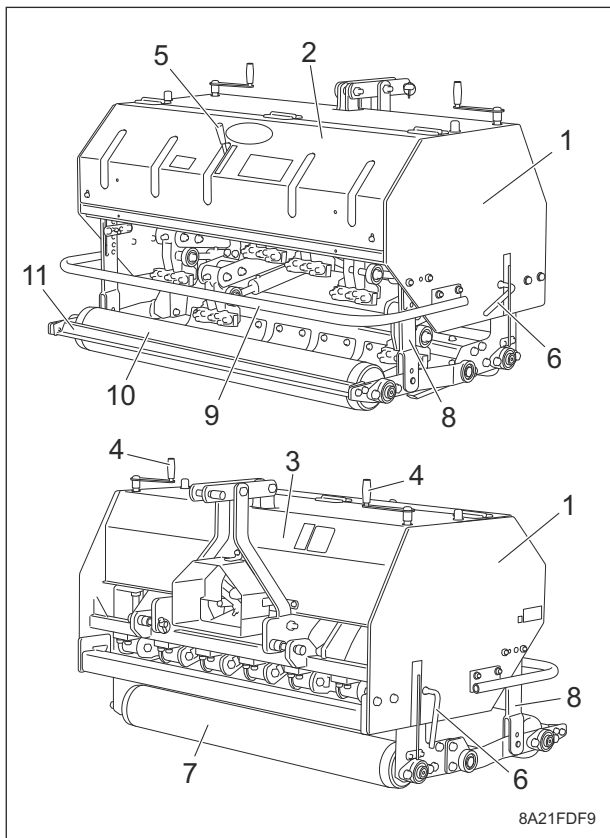

Names of Each Section_001

1	Frame
2	Rear cover
3	Front cover
4	Up-down handle
5	Change lever
6	Roller holding fixture
7	Front roller
8	Roller hanger
9	Protection pipe
10	Rear roller
11	Scraper

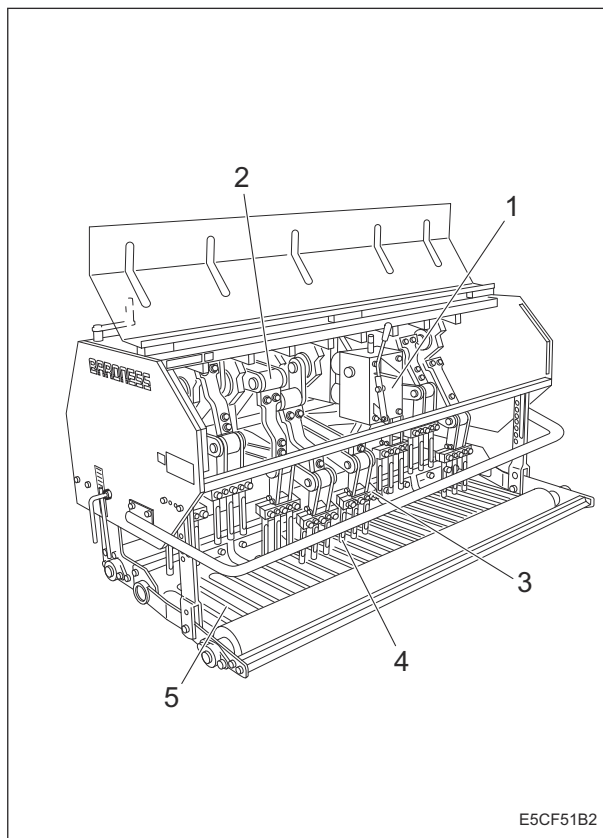

Names of Each Section_002

1	Gear box
2	Tine mount holder
3	Tine mount
4	Tine
5	Lawn pressing plate

Regulation Decals

Positions of Regulation Decals

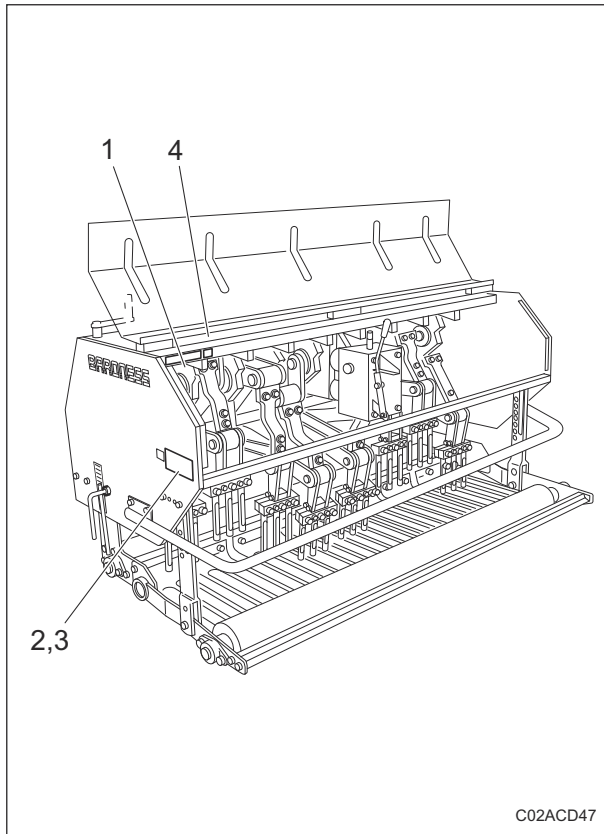

Positions of Regulation Decals_001

1	Serial number plate
2	Specification decal
3	CE Mark
4	Year of manufacture decal

Description of Regulation Decals

Serial Number Plate

The following information is written on the serial number plate.

1. Model
 2. Serial number
 3. Registered trademark
 4. Manufacturer
 - Company name
 - Postal address/Address
 - Website
- Contact the manufacturer via the contact form on the website.



Serial Number Plate_001

Product Overview

Specification Decal

(For EU)

The Specification decal indicates the model and weight, etc.

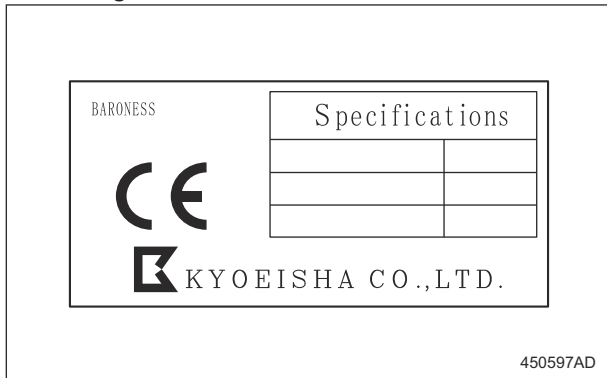

Specification Decal_001

CE Mark

(For EU)

CE mark indicates that the machine sold in the EU nations complies with the EU requirements.

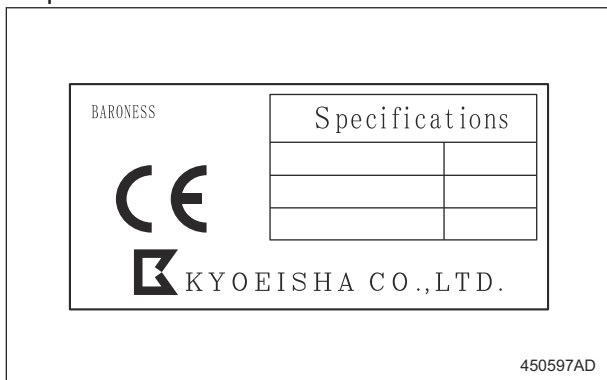

CE Mark_001

Year of Manufacture Decal

(For EU)

The year of manufacture decal indicates the year when this machine was manufactured.



Year of Manufacture Decal_001

Safety Signs and Instruction Signs

About Safety Signs and Instruction Signs

Important

Safety decals and instruction decals are attached to this product. Make sure that they are preserved in their entirety. If they are damaged, become dirty, or peel off, replace them with new ones.

Part numbers for decals that need to be replaced are listed in the parts catalog. Order them from a Baroness dealer or Kyo-eisha.

Positions of Safety Decals and Instruction Decals

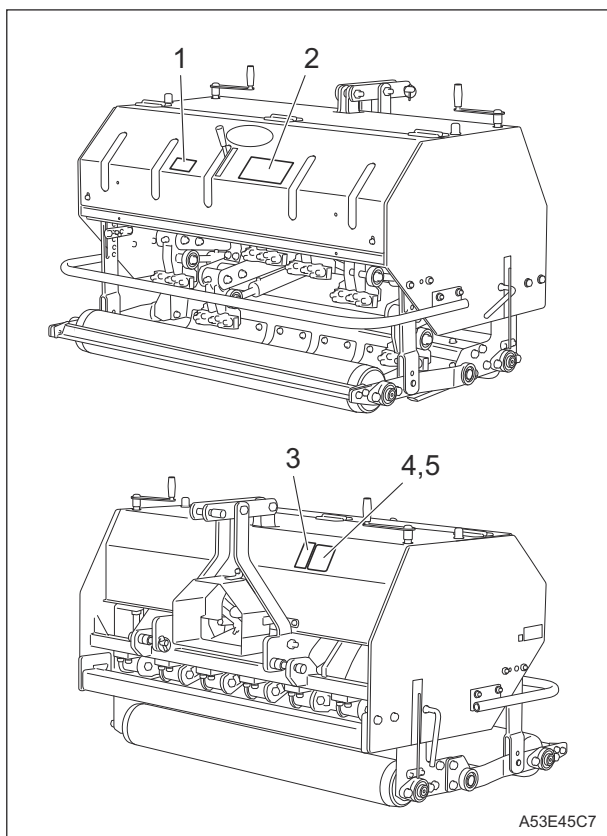

Positions of Safety Decals and Instruction Decals_001

1	Prohibition of riding decal
2	Handling precautions decal
3	PTO caution decal
4	PTO max 400 rpm decal (TDA1200)
5	PTO max 1000 rpm decal (TDA1600)

Description of Safety Decals and Instruction Decals

Prohibition of Riding Decal

K4205002300
Decal, Prohibition of riding

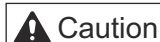

Do not ride on the machine.



Prohibition of Riding Decal_001

91279435

Product Overview

Handling Precautions Decal

K4205001750
Decal, handling precautions

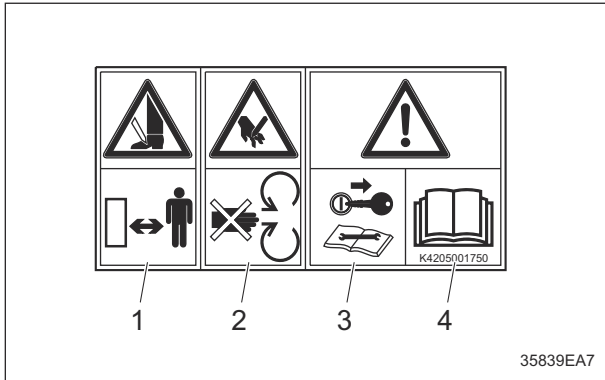

Handling Precautions Decal_001

1.

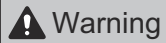

May cut your hand or leg - Make sure that people around the machine keep a safe distance during operation.

2.

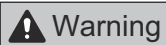

May cut your hand - Keep your hands away from moving parts.

3.

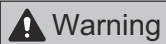

Remove the ignition key for maintenance.

4.

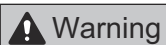

Read the Owner's Operating Manual.

PTO Caution Decal

K4205001760
DECAL, CAUTION PTO

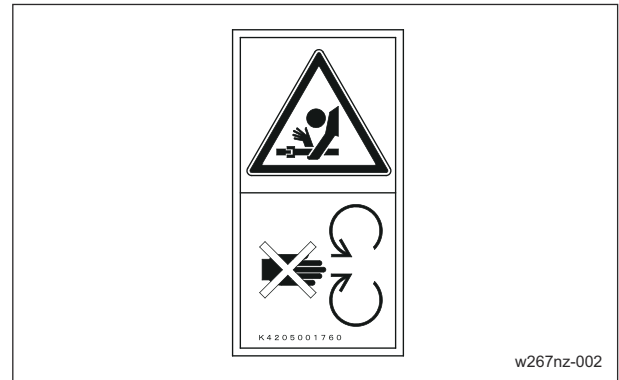
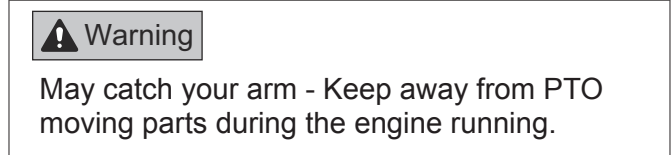

PTO Caution Decal_001

PTO Max 400 rpm Decal

K4209001570
DECAL, PTO MAX 400 RPM
It indicates PTO maximum rotation speed.
Maximum rotation speed is 400 rpm.

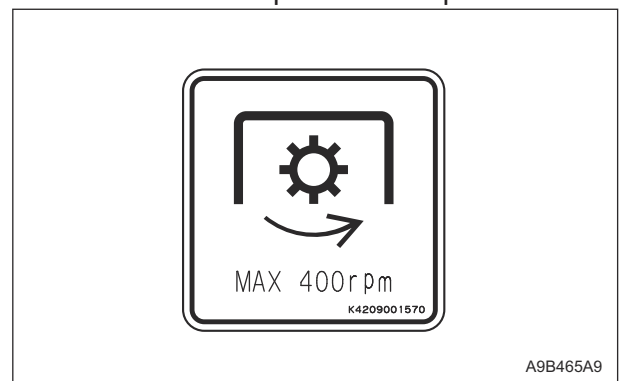

PTO Max 400 rpm Decal_001

Product Overview

PTO Max 1000 rpm Decal

K4209001560
 DECAL, PTO MAX 1000 RPM
 It indicates PTO maximum rotation speed.
 Maximum rotation speed is 1000 rpm.

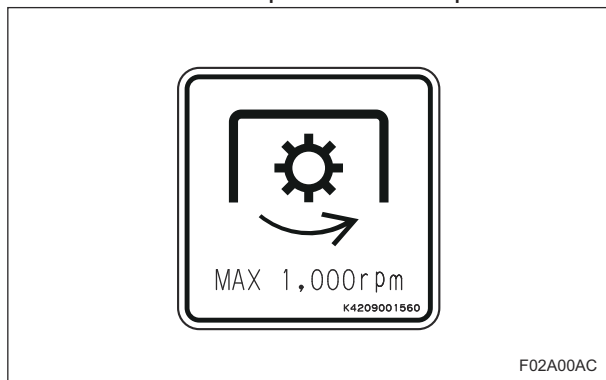

PTO Max 1000 rpm Decal_001

Description of Operation Decals

Depth Adjusting Handle Decal

K4203001400
 DECAL, DEPTH ADJUSTING HANDLE
 It indicates the tine depth.

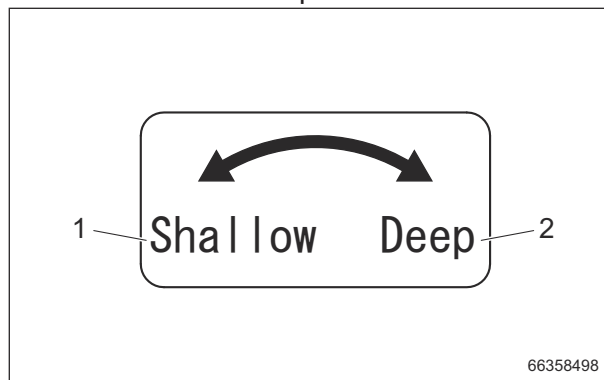

Depth Adjusting Handle Decal_001

1	Shallow
2	Deep

Operation Decals

Positions of Operation Decals

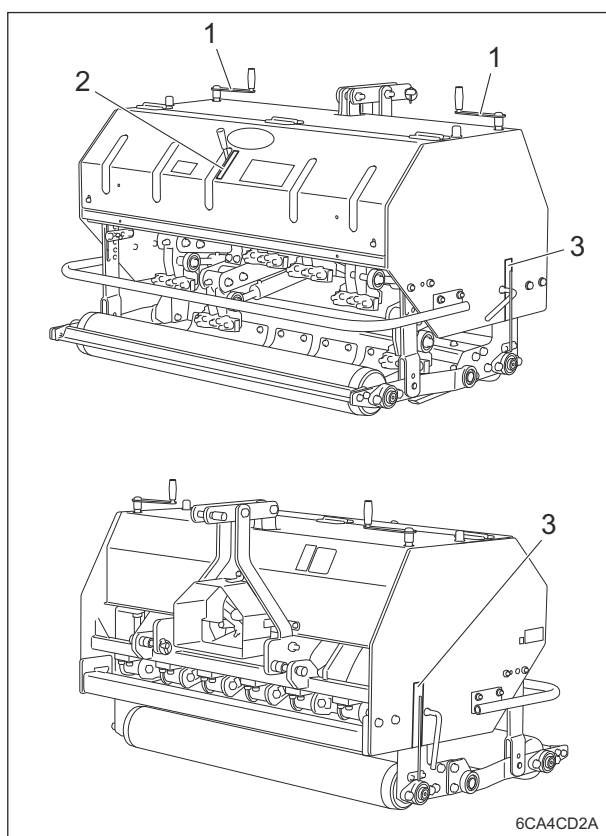

Positions of Operation Decals_001

1	Depth adjusting handle decal
2	Crank effect speed decal
3	Scale decal 150A

Crank Effect Speed Decal

K4203001390
 DECAL, CRANK EFFECT SPEED
 It indicates the crank rotation speed.

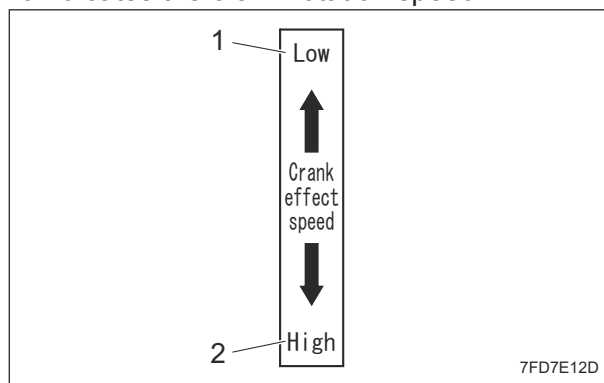

Crank Effect Speed Decal_001

1	Low
2	High

Product Overview

Scale Decal 150A

K4209001140

LABEL, SCALE 150A

It indicates the scale of the tine depth.

One scale corresponds to 10 mm (0.39 in).

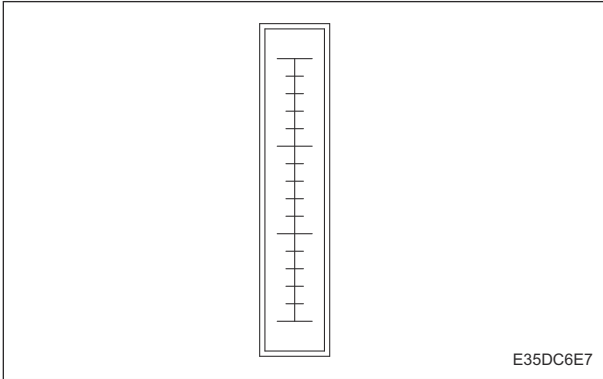

Scale Decal 150A_001

Description of Functions

Change Lever Page 4-2
Up-Down Handle Page 4-2
Rear RollerPage 4-3

Description of Functions

Change Lever

Warning

Be sure to stop the PTO rotation to shift the change lever.

Important

If it is hard to engage the change lever for switching, depress the clutch pedal of the tractor once more to make it easier. If you force to engage the change lever, it may cause damage to the transmission and change lever.

The change lever shifts the high/low speed of crank rotation. Shift the lever to the appropriate position.

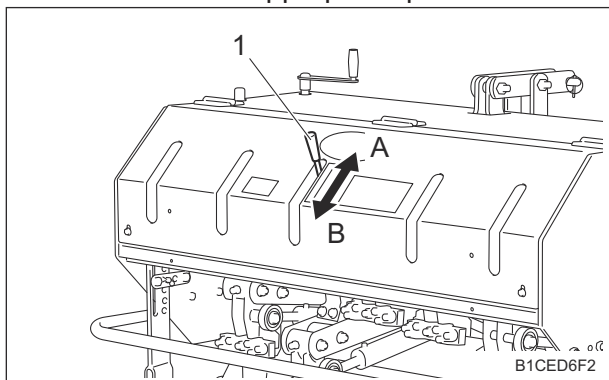

Change Lever_001

1	Change lever
A	Low speed
B	High speed

Up-Down Handle

The up-down handle adjusts the tine depth. Turn the handle to the appropriate direction.

1. Turn the handle clockwise to increase the coring depth. (Roller goes up, and frame goes down.)
2. Turn the handle counterclockwise to decrease the coring depth. (Roller goes down, and frame goes up.)

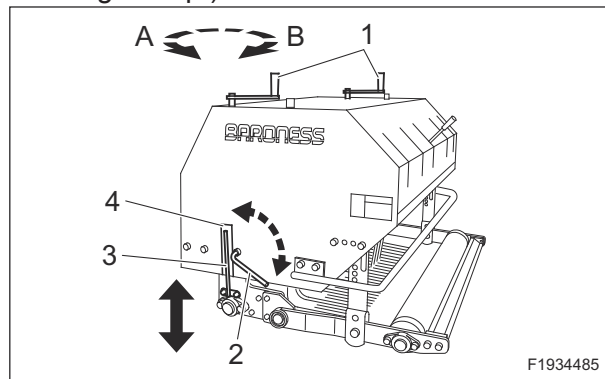

Up-Down Handle_001

1	Up-down handle
2	Roller holding fixture
3	Depth gauge
4	Scale decal
A	Shallow
B	Deep

Rear Roller

1. When using the rear roller

When operating the coring with spike tines, the machine presses the lawn surface by using the rear roller.

- [1] Remove the snap pin, and remove the flat head pin securing the rear roller from the hole B.
- [2] Insert the flat head pin into the hole A on the roller holding plate, and insert the snap pin to release the rear roller.
- [3] Do the same operation on the opposite side to release the rear roller.

2. When not using the rear roller

When operating the coring with side open tines, the machine does not press the grass and soil removed by the side open tines by raising the rear roller.

- [1] Remove the snap pin, then the flat head pin.
- [2] Raise the roller hanger to the appropriate height where the rear roller cannot press the grass and soil removed by the side open tines.
- [3] Insert the flat head pin into the hole B on the roller holding plate and insert the snap pin to release the rear roller.
- [4] Raise the opposite side in the same way and fix it. Do the same operation on the opposite side to fix the rear roller.

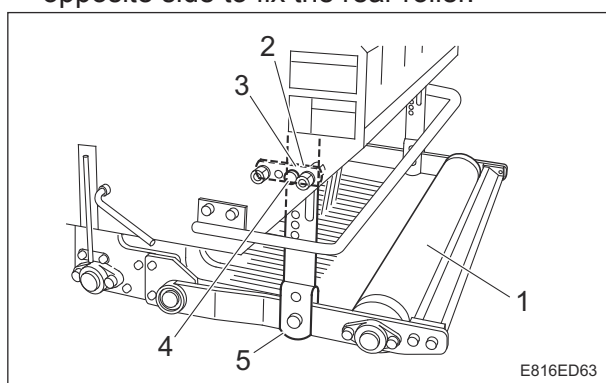

Rear Roller_001

1	Rear roller
2	Roller holding plate
3	Snap pin
4	Flat head pin
5	Roller hanger

Description of Functions

Preparation for Installation Page 5-2

- Tractor Standards Page 5-2
- Preparation on The Tractor Page 5-2

Installation Page 5-2

- Precautions about Installation Page 5-2
- Installation of Attachment Page 5-2
- Installation of Universal Joint Page 5-3
- Method of Cutting Universal Joint Page 5-5

Inspection before Use Page 5-6

- Precautions for Inspection Page 5-6
- Inspection of Tines Page 5-6
- Inspection of Lawn Pressing Plate Page 5-6
- Inspection of Spring Box Page 5-6
- Inspection of Covers Page 5-6
- Inspection of Rollers Page 5-6
- Inspection of Gear Oil Page 5-7
- Inspection of Universal Joint Page 5-7
- Inspection of Bolts and Nuts Page 5-7
- Inspection of Liquid Leakage Page 5-7

Move Page 5-8

- Precautions for Traveling Page 5-8
- Traveling Procedure Page 5-8

Operations Page 5-8

- Precautions for Operation Page 5-8
- Aeration Procedure Page 5-10

Transporting Page 5-11

- Transporting Procedure Page 5-11

Cleaning after Use Page 5-11

- Precautions for Cleaning Page 5-11
- Cleaning of Aeration Section Page 5-11

Storage Page 5-11

- Short-Term Storage Page 5-11

Handling Instructions

Preparation for Installation

Tractor Standards

This attachment employs "standard three-point link" mounting system.

In the "standard three-point link", attach the top link of the tractor and the universal joint of this machine by hand.

Preparation on The Tractor

Important

Read the "Three-point link standards" in the tractor's owner's manual carefully.

Important

Only the tractors equipped with standard three-point link parts can be connected to this machine.

If the tractor is equipped with specific three-point link, remove the top link bracket for specific three-point link and replace it with standard three-point link parts.

Important

Use the length-adjustable top link with a screw on the both ends.

1. Attach the lift rod to the front hole of the lower link.

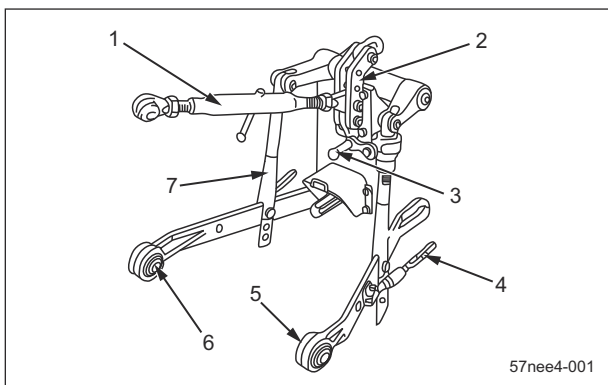

Preparation on The Tractor_001

1	Top link
2	Top link bracket
3	Leveling handle
4	Turn buckle
5	Right lower link
6	Left lower link
7	Lift rod

2. If the moving distance when raising and lowering the attachment is insufficient, adjust it by changing the mounting holes on the lift rod.

- Use the upper hole to increase the moving distance when raising.
- Use the lower hole to increase the moving distance when lowering.

Installation

Precautions about Installation

Warning

Make sure there is no one around the tractor and between the attachment and the tractor.

Warning

Do not get under the attachment. Do not put your foot under the attachment.

Warning

Before installing the attachment, apply the parking brake of the tractor, set the PTO speed change lever to the "Neutral" position and stop the engine.

Warning

When installing the attachment, install the tractor's genuine balance weights to adjust balance. Otherwise, the machine may lose balance and overturn.

Caution

Attach and detach the attachment on a flat, stable place.

Caution

Two or more workers should attach and detach the attachment since it is very heavy.

Installation of Attachment

1. Place the attachment on a flat and stable area.
2. Drive the tractor in reverse toward the attachment, in alignment with the center of the attachment mount.

Handling Instructions

3. Lower the three-point link parts of the tractor to their lowest positions.
4. Apply the parking brake of the tractor, and then stop the engine.
5. Chock the wheels of the tractor.
6. Install the left lower link, and then lock the link pin.
7. Use the leveling handle for the lift rod on the right side to move the lower link up or down to align it with the pin.
8. Install the right lower link, and then lock the link pin.
9. Align the attachment mounting hole in the top link (upper link) with the mounting holes in the attachment.
If the mounting hole in the top link (upper link) cannot be aligned, loosen the lock nut on the top link, and then adjust the length.
10. Install the top link (upper link), lock the link pin, and then tighten the lock nut.

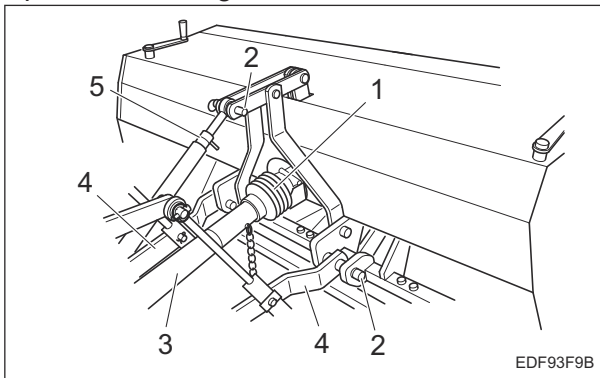

Installation of Attachment_001

1	Protective cover
2	Link pin
3	Universal Joint
4	Lower link
5	Top link (Upper link)

11. Start the engine of the tractor, and then operate the lift lever to slightly raise the attachment.

Important

When the attachment swings, this may cause damage to the lawn, tractor or the attachment.

12. Adjust the top link (upper link) to make the attachment level.

13. Adjust the top link (upper link) so that the attachment swings only 10 - 20 mm (0.39 - 0.79in) on the right and left sides evenly. Check the swing on the right and left sides of the attachment. When the swing is large, adjust the turnbuckles outside of the right and left lower links to reduce the play.

Note:

For removing the attachment, reverse the installation procedure.

Installation of Universal Joint

Important

The length of the universal joint depends on the model of the tractor to be installed.

Important

Do not install a universal joint that is either too long or short.

If the universal joint is too long, it may strike the PTO shaft of the tractor or the input shaft of the attachment.

If the universal joint is short, the universal joint engagement will be insufficient, causing damage.

Important

Do not raise the attachment with only one side of tractor's lower links installed.

Important

Do not keep the universal joint rotating while the attachment is raised.

Otherwise, the universal joint and the attachment may become damaged.

1. Set the PTO speed change lever of the tractor to the "Neutral" position.
2. Slowly raise or lower the attachment to adjust the input shaft of the attachment to the same height as the PTO shaft of the tractor.
3. Fully close the hydraulic stop valve.
Note:
Read the tractor's owner's manual for the location of the hydraulic stop valve.
4. Apply the parking brake of the tractor, and then stop the engine.

Handling Instructions

5. Hang the chain attached to the universal joint onto the top link (upper link).

Important

Be sure to install the universal joint clutch part to the attachment side.

6. Install the universal joint onto the attachment.

[1] With pulling the clutch part set cover, push the universal joint onto PTO shaft until the locking device engages.

* Make sure that the knock pin and set cover have returned to their original positions.

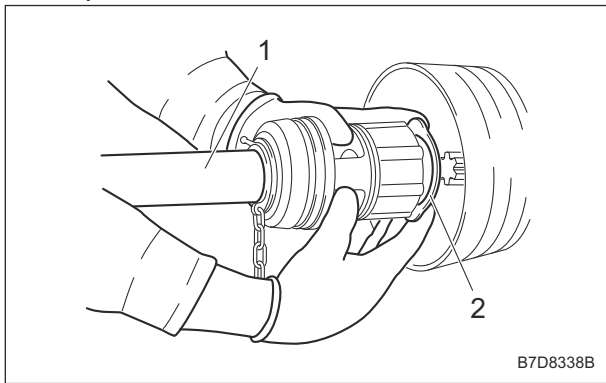

Installation of Universal Joint_001

1	Universal joint
2	Set cover

Important

Do not forcefully insert the universal joint by striking it with a hammer, etc. Otherwise, the joint may become damaged.

7. Install the universal joint onto the tractor.

[1] Fully compress the joint, and if there is a space of 10 mm (0.39 in) between the tip of the joint and the PTO shaft of the tractor, install the joint.

Note:

If there is no space, cut the universal joint.

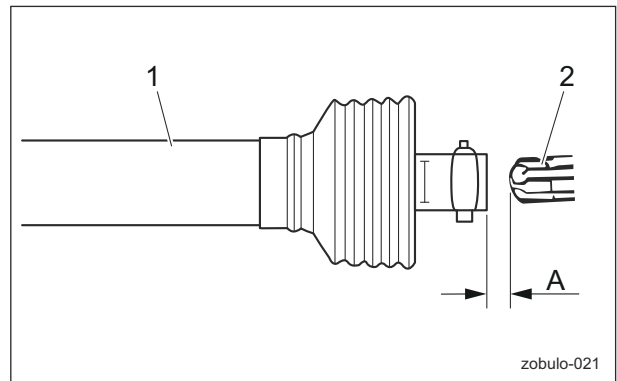

Installation of Universal Joint_002

1	Universal joint
2	Tractor (PTO shaft)
A	10 mm (0.39 in)

[2] With pushing the knock pin, push the universal joint onto PTO shaft until the pin engages.

* Attach it with the tractor's PTO speed change lever in neutral.

[3] Insert it until the knock pin locks.

* Make sure that the knock pin and set cover have returned to their original positions.

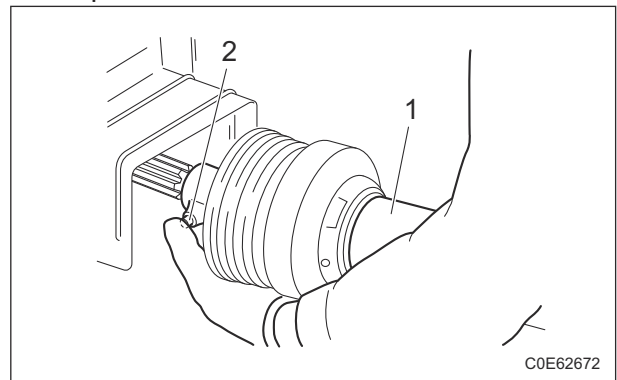

Installation of Universal Joint_003

1	Universal joint
2	Knock pin

8. Hang the chain for stopping protective cover rotation on the top link (upper link) and install it to the lower link hook.

9. Start the engine of the tractor.

Handling Instructions

Caution

Rotating the PTO shaft will rotate the tine mount holder.

10. Rotate the PTO shaft while the attachment is lowered (rear tire contacting the ground), and check that the universal joint and attachment make no abnormal sound.

Method of Cutting Universal Joint

Caution

Work with great caution when using a high speed cutter.

Important

The universal joint length depends on the type of tractor to be linked.

1. Hold the half shafts of universal joint next to each other in the shortest working position between the tractor and attachment, and mark them.
2. Cut the inner and outer guard tubes at the marked positions.

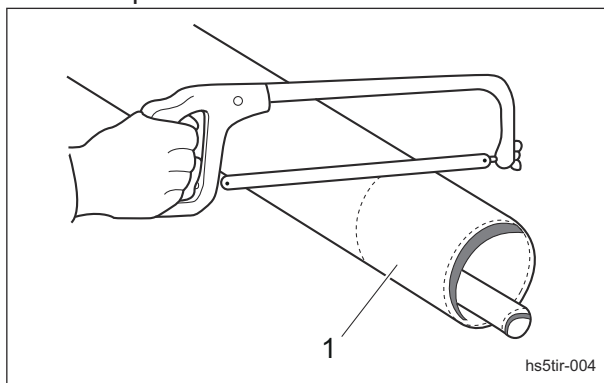

Method of Cutting Universal Joint_001

1	Guard tube
---	------------

3. Mark the shaft at the same length from its tip as the removed guard tube.

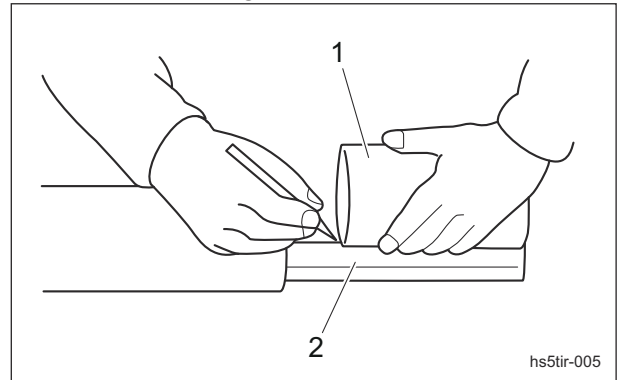

Method of Cutting Universal Joint_002

1	Guard tube
2	Shaft

4. Cut the inner and outer shafts at the marked position.

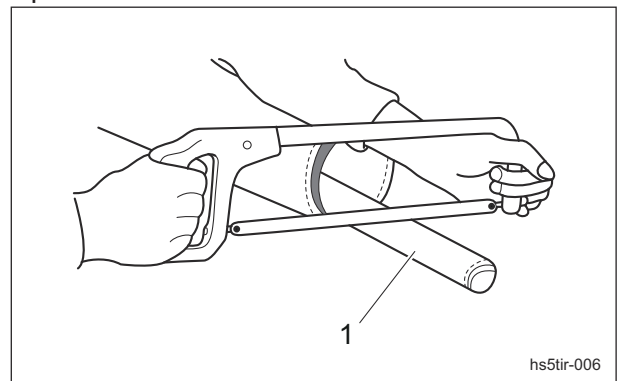

Method of Cutting Universal Joint_003

1	Shaft
---	-------

5. Round off all sharp edges, remove burrs and clean the shafts.

Handling Instructions

Inspection before Use

The purpose of the machine inspection is to:

- Prevent accidents
- Prevent damage to the machine
- Maintain machine performance

Detecting machine malfunctions early helps prevent unexpected problems from occurring.

If you detect any abnormalities with the machine, immediately perform maintenance or repairs.

Precautions for Inspection

Warning

Before inspecting an attachment installed on the tractor, be sure to apply the parking brake of the tractor, set the PTO speed change lever to the "Neutral" position, then stop the engine.

Inspection of Tines

Caution

Wear gloves when touching tines to avoid cutting your hands.

1. Make sure that the tines are not bent.
2. Make sure that the tines are not chipped.
3. Check how much the tines are worn.
The operating depth cannot be maintained if tine wear is 10 mm (0.39 in) or more.
4. Make sure that the edges of tines are not too blunt, making cutting difficult.
5. Make sure that the mounting bolts for the tines are not loose.
6. Check how much the sliding plate of the tine mount section is worn.

Inspection of Lawn Pressing Plate

1. Make sure that there is no deformation of the lawn pressing plate.
2. Make sure that there are no cracks or damage to the lawn pressing plate.
3. Make sure that the mounting bolts for the lawn pressing plate are not loose.

Inspection of Spring Box

1. Confirm that there is no crack nor tear in the bearing housing of the spring box.
2. Confirm that there is no crack nor tear in the bearing housing of the spring shaft.
3. Make sure that there is no wear or rust of the bearing.
4. Make sure that there is no play in the fit of the shaft and the bearing.
5. Make sure that the hole of the fastening bracket is not worn.
6. Make sure that the spring box operates correctly.

Inspection of Covers

Warning

If you have removed a protective cover during inspection, be sure to securely install it in its original position.

If a protective cover remains removed, foreign objects may fly off, and the operator or the mechanic can be injured.

1. Make sure that there is no wear or deterioration of protective covers.
2. Make sure that there is no damage to protective covers.
3. Make sure that there is no interference with moving parts due to deformation of protective covers.
4. Make sure that protective covers are installed in their appropriate positions.

Inspection of Rollers

1. Make sure that there is no abrasion nor adhesion of the roller.
2. Make sure that there is no wear of the roller shaft.
3. Make sure that there is no wear nor damage of the oil seal.
4. Make sure that there is no wear nor rust of the bearing.
5. Make sure that there is no play in the roller shaft.

Handling Instructions

Inspection of Gear Oil

1. On a level surface, check that the oil level reaches the middle of the oil gauge.
2. Check underneath the machine for oil leakage.

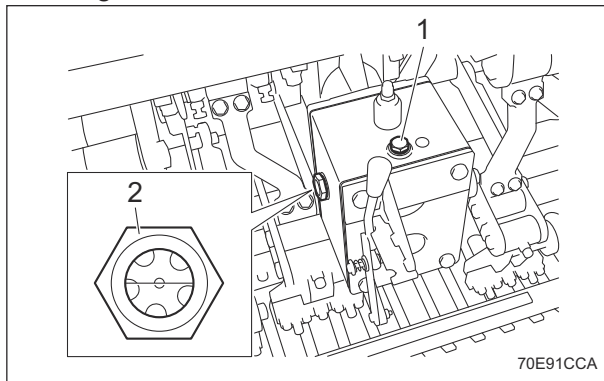

Inspection of Gear Oil_001

1	Oil filler cap
2	Oil gauge

Inspection of Universal Joint

1. Inspect the chain for damage, abnormal wear and so on.
2. Inspect the cover for cracks, damage, abnormal wear and so on.

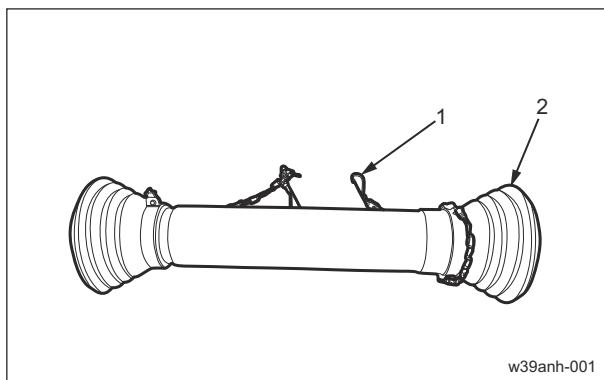

Inspection of Universal Joint_001

1	Chain
2	Cover

Inspection of Bolts and Nuts

Important

The bolts and nuts may be loosened at the earlier stage of the use.
Be sure to retighten or replace before operating the machine whenever there is any abnormality.

1. Check the bolts and nuts for looseness and coming off.

2. Check the bolts and nuts for cracks and damages.
3. Check the bolts and nuts for rust.
4. Check around the bolts and nuts for traces of rust fluid.
5. Check for unequal bolt length.
6. Check the bolts and nuts for stripped threads and abrasion.

Inspection of Liquid Leakage

Important

After approximately 50 hours of operation, some tightened portions may be loosened and liquid such as oil may leak.
Be sure to retighten the parts.

Important

If liquid leakage found, repair it before operation.
Ignoring leakage will cause further trouble.

1. Check the bottom of the machine for leakage of liquid such as oil, water, etc.
2. Locate the leakage and identify the type of liquid.

Handling Instructions

Move

Precautions for Traveling

Warning

The traveling speed for a tractor with the attachment installed should be 10 km/h or less. Especially when traveling up and down slopes, be sure to travel at such a speed that you can stop immediately for emergencies.

Warning

If the front of the tractor feels as if it lifts off the ground on slopes, steering ability may become affected or the machine may roll over. Add genuine balance weights from the tractor manufacturer to the front part of the tractor according to the tractor's owner's manual.

Important

If a tractor with the attachment installed travels at maximum speed, the attachment will be damaged by violent shaking.

Traveling Procedure

Warning

Do not rotate the PTO while traveling.

1. Start the engine of the tractor, and then increase the engine speed.
2. Raise the attachment to the maximum position by using the attachment up/down lever (hydraulic lever) of the tractor.
3. Travel, driving slowly.

Operations

Precautions for Operation

Warning

Do not operate the machine in places in danger of a land subsidence or landslide.

Warning

The machine may overturn on a slope with an irregular surface. Do not operate the machine in such a place.

Warning

Avoid operation on slopes.

Warning

The machine will be in danger of slipping and overturning on a wet slope. Do not operate the machine in such a condition.

Warning

Check to see if someone is playing in the vicinity. There is a possibility of getting struck with a hit ball.

Warning

Check the surroundings for safety (front, back, right, and left, as well as trees, ditches, irregular surface of the green, sprinklers, and cups etc.) during operation. Operate the machine at an appropriate speed so that you can stop the machine any time in an emergency. Avoid sudden acceleration, sudden braking, and abrupt steering. Drive the machine slowly especially when descending a slope.

Warning

When the tractor equipped with the attachment, the total length of tractor increases. Be careful of the people and objects around the machine when turning the machine.

Warning

Do not touch the moving sections during operation, otherwise your fingers or hands may get injured.

Handling Instructions

Warning

Do not operate the machine at night time or in bad weather when the visibility is poor.

Caution

Remove stone, wire, sticks, and other obstacles before work, otherwise not only troubling the attachment but also causing an accident due to the scattering of such objects.

Caution

When leaving the machine, park the machine on a flat ground.
Carefully lower the attachment so that the tines will not touch on the ground.

Caution

When abnormal vibration, abnormal sound (wire or vinyl coiling tangled in the aeration section), or other anomaly occurs in the machine during work, stop the engine immediately and investigate into the cause. Completely repair the machine before operating it again.

Caution

When colliding with some obstacle, stop the tractor engine and check up whether respective parts are not damaged.

Important

Do not move forward without rotating the PTO shaft when lowering the attachment, otherwise the lawn and attachment will be damaged heavily.

Important

Lower the attachment slowly so that the lawn and attachment will not be damaged.

Important

Do not move backward nor turn when the attachment is lowered and touched on the ground, otherwise the lawn and attachment will be damaged heavily.

Important

When stone or rock is expected to exist under the ground, lower the speed of PTO rotation.

Important

Select an appropriate tine depth in consideration of the working condition. Operating the machine without any consideration of the working condition applies excessive force to the machine, and causes damage to the machine.

Important

Make sure that the front roller touches on the ground when engaging the tractor's PTO. When the coring depth is too deep, the roller may be lifted according to the condition of the soil, it possibly causes damage to tractor's PTO section and the attachment.

Important

Large tines or attachments may cause the tine mount holder to be lifted. Slow down the PTO rotation speed or stop the machine before the tine mount holder overturns.

Important

Do not rotate the universal joint at an angle exceeding 30 degrees.

Important

Carefully select the coring depth according to the condition of the green.
If the coring surface is too hard, it will apply excessive force to the driving system of the machine, causing breakage. Decrease the tine depth in such a condition.

Important

Excessively high-speed PTO rotation will apply excessive force to the machine, causing breakage of the machine or spouting of oil from the gearbox.

Handling Instructions

Important

High-speed operation will decrease the work effectiveness.

Select an appropriate working speed according to the condition.

Important

Meandering operation may damage the green. Move the machine straight.

Important

Do not reverse the PTO rotation, otherwise the machine will be damaged.

Important

Operate the machine at an appropriate speed to prevent the front roller from bouncing.

Operating the machine with the front roller bouncing may damage the attachment.

Aeration Procedure

Important

The standard working speed of tractor is 5 - 8 km/h.

Operate at low speed in the case of deep tine depth.

1. Raise the attachment and travel to the work site.
2. Select the crank rotation speed using the change lever.
3. Combine the tractor's main shift and range shift positions to select the required operating speed.
4. Set the tractor's engine rotation at low speed less than 1500 rpm.
5. Slowly lower the attachment.

6. Engage the tractor's PTO speed change lever to rotate the crank and move the tractor forward at the same time.

Important

The speed of the engine rotation while operating the tractor is as stated below.

- TDA1200: 1,600 - 2,000 rpm
- TDA1600: 1,800 - 2,300 rpm

The speed of the PTO rotation should be as stated below.

- TDA1200: 400 rpm
- TDA1600: 1,000 rpm

Use with the PTO rotation speed exceeding as stated above will cause damage to the machine.

7. Gradually increase the tractor's engine rotation speed until it reaches the set value of the PTO rotation speed.

Note:

Keep the front roller in contact with the ground at all times during operation. If the machine becomes unstable, change the PTO rotation speed to stabilize the machine. If it does not stabilize, change the coring depth, change the size of tines, or change the tines with new ones.

Important

Do not stop the tractor's engine during operation. Otherwise, the transmission will malfunction.

8. After completing the operation, raise the attachment, and then stop the tractor.
9. Raise all the tines off the ground, and then immediately stop the rotation of the PTO.
10. Move to the next operation site, and then perform the above procedure.

Handling Instructions

Transporting

Transporting Procedure

Transporting the attachment installed to a tractor:

When loading the machine into a trailer or a truck to transport it, drive the tractor in reverse. When unloading, drive the tractor forward.

Transporting only the attachment:

When loading the attachment into a trailer or a truck to transport it, put the attachment on a pallet and then load and unload the pallet. Before transportation, fix the attachment on board.

Cleaning after Use

The purpose of the machine cleaning is to:

- Prevent accidents
- Prevent damage to the machine
- Maintain machine performance

Properly clean the machine to maintain its functionality and performance.

If you detect any abnormalities with the machine, immediately perform maintenance or repairs.

Precautions for Cleaning

Warning

Before cleaning an attachment installed on the tractor, be sure to apply the parking brake of the tractor, set the PTO speed change lever to the "Neutral" position, then stop the engine.

Cleaning of Aeration Section

Be sure to clean the aeration section after use.

1. Stop the engine of the tractor, and then remove the key.
2. Carefully clean the inside and outside of the aeration section with water or compressed air.

Storage

Short-Term Storage

Short-term storage means that the attachment is temporarily stored (within 1 month) without use.

Follow the instructions below for short-term storage of this attachment.

1. Cleaning

- Remove any dirt, grass, debris, or oil stains completely.

2. Storage location

- Cover the machine and store it in a dry place where it will not be exposed to rain.
- As for storage of the attachment detached from the tractor, place it on a flat surface.

Handling Instructions

Precautions for MaintenancePage 6-2

Supplying Fluids Page 6-2

 Supply of Gear Oil Page 6-2

Greasing Page 6-2

 About GreasingPage 6-2

 Greasing pointsPage 6-3

Adjustment Page 6-5

 Precautions for Adjustment Page 6-5

 Adjustment of Tine Depth Page 6-5

Replacement Page 6-6

 Change of Tines Page 6-6

 Change of Gear OilPage 6-6

Storage Page 6-7

 Long-Term Storage Page 6-7

Maintenance

Precautions for Maintenance

Warning

The chapter "Maintenance" in this manual describes practical measures which should be performed by a mechanic with expertise. The owner should instruct the mechanic with expertise to perform maintenance service for this machine.

Caution

First, learn well the operations you plan to perform.

Important

Use tools appropriate for each operation.

Important

Use Barons genuine parts for replacement and accessories. Our product warranty may be void if you use non-genuine parts for replacement or accessories.

Supplying Fluids

Supply of Gear Oil

Important

Do not mix the different types of gear oil.

Important

Use BONNOC TS680 (or equivalent) as gear oil.

1. When the gear oil level is low, follow the steps below to supply oil.
 - [1] Open the oil filler cap.
 - [2] Supply gear oil through the oil filling port until the oil level reaches the middle of the oil gauge.

[3] Tighten the oil filler cap securely.

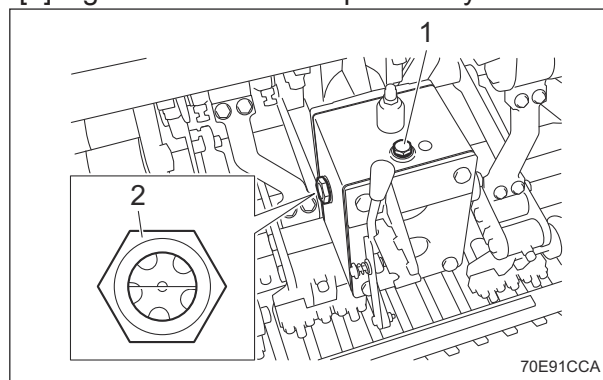

Supply of Gear Oil_001

1	Oil filler cap
2	Oil gauge

2. On a level surface, check the oil level is at the middle of the oil gauge. If necessary, supply oil.
3. Check underneath the machine for oil leakage.

Greasing

About Greasing

Since there may be adhesion or damage due to lack of grease on moving parts, they must be greased.

Add urea-based No. 2 grease in accordance with the Maintenance Schedule.

Other locations where the specified grease or lubricant is used are indicated in "Greasing Points".

Add grease using the specified grease or lubricant.

Greasing points

Grease nipples are installed in the following locations.
 Add grease every 50 hours of operation.

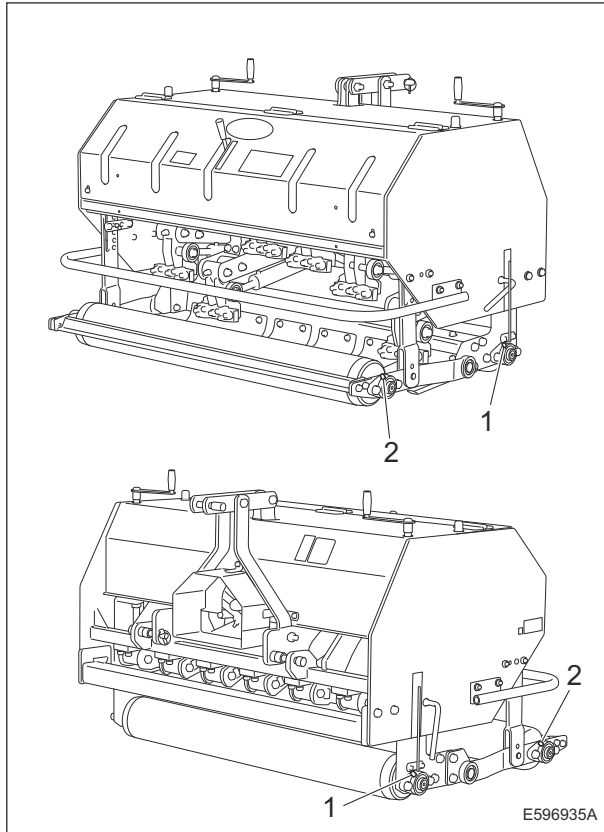

Greasing points_001

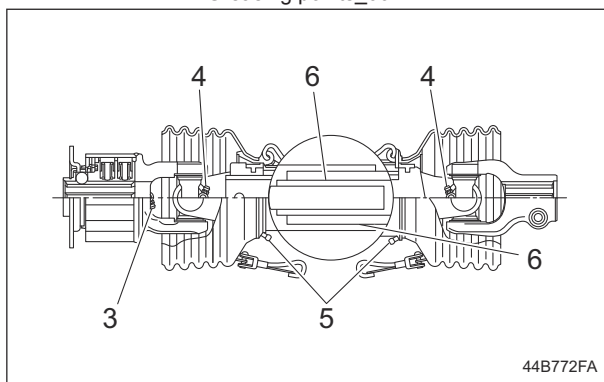

Greasing points_002

	Location	No. of Greasing Points
1	Rear roller	2
2	Front roller	2
3	Clutch on universal joint	1
4	Journal cross on universal joint	2
5	Safety cover on universal joint	2
6	Slide on universal joint	1

1. Rear roller

There is one point each on the right and left side of the rear roller.

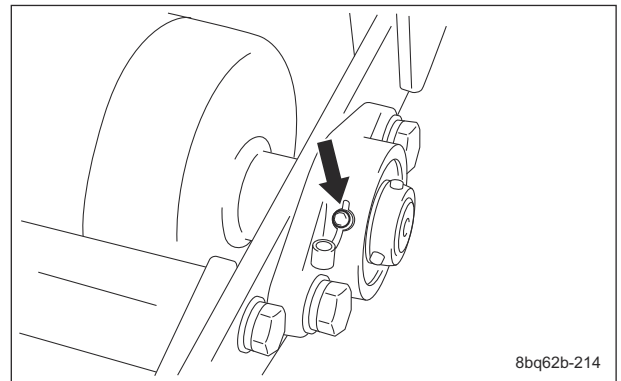

Greasing points_003

2. Front roller

There is one point each on the right and left side of the front roller.

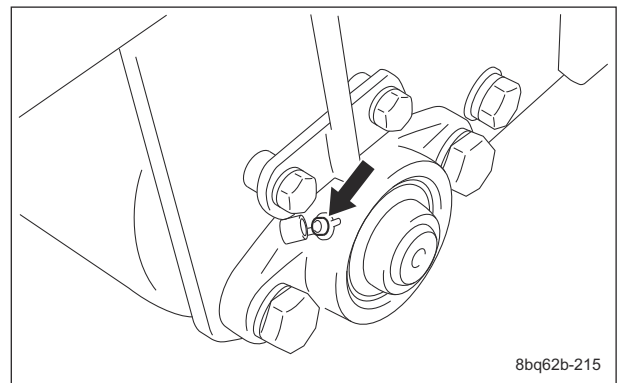

Greasing points_004

3. Clutch on universal joint

Use lithium grease (urea type) with molybdenum.

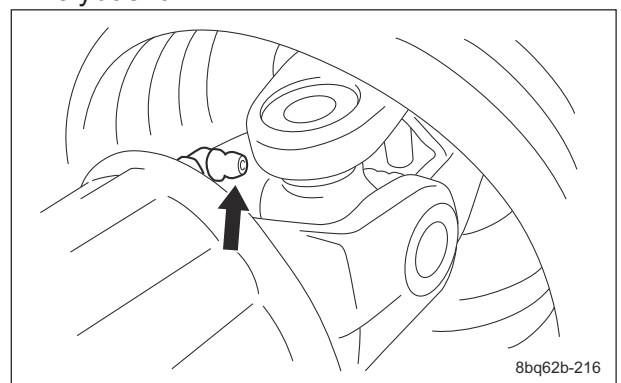

Greasing points_005

Maintenance

Maintenance

4. Journal cross on universal joint

Use lithium grease (urea type) with molybdenum.

There is one point each on the journal cross.

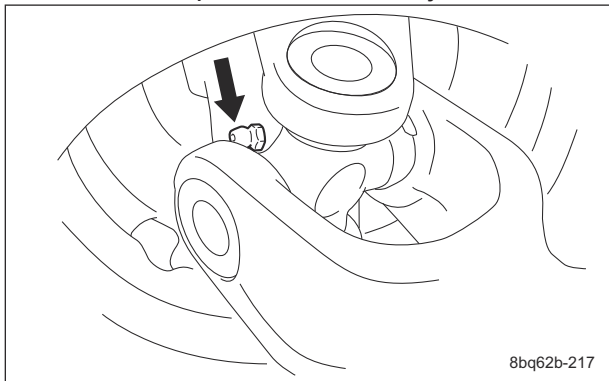

Greasing points_006

5. Safety cover on universal joint

Use lithium grease (urea type) with molybdenum.

There is one point each in safety covers.

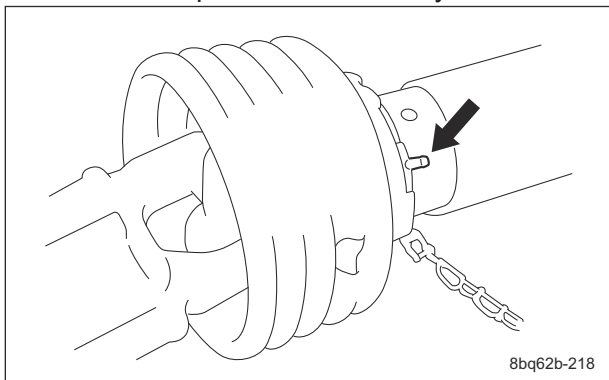

Greasing points_007

6. Slide on universal joint

Pull out the shaft and apply grease inside and outside of the shaft.

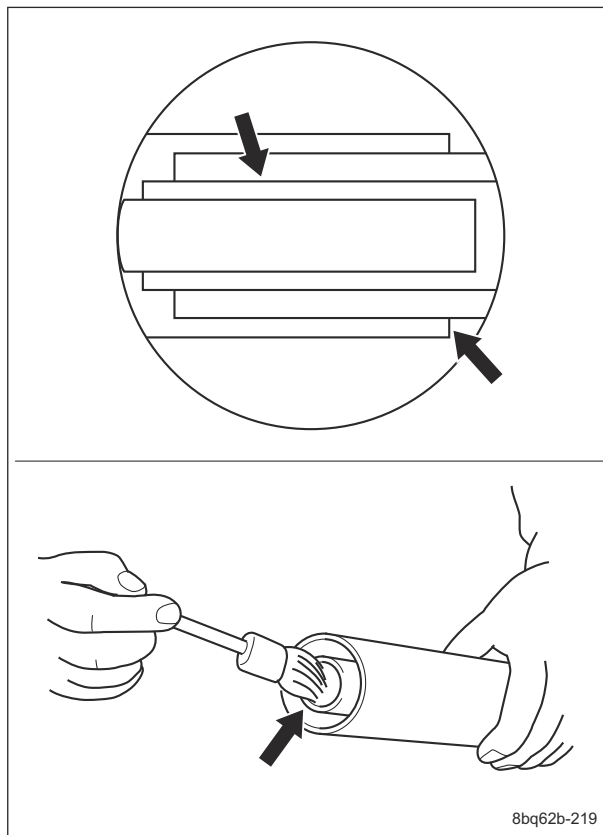

Greasing points_008

Adjustment

Precautions for Adjustment

Warning

Make sure that no one is near the tractor or between it and the attachment.

Warning

For adjusting the attachment with the attachment installed on the tractor, be sure to apply the parking brake of the tractor, set the PTO speed change lever to the "Neutral" position and stop the engine.

Adjustment of Tine Depth

Important

Select an appropriate tine depth in consideration of the working condition. Operating the machine without any consideration of the working condition applies excessive force to the machine, and causes damage to the tines and the machine. When setting the tine depth deeper, slow down the working speed as necessary.

Important

When moving the front roller up and down, move the right and left up-down handles two turns alternately. When one side alone is moved up and down, the scraper and lawn pressing plate bracket will be deformed.

Important

The scale decal does not indicate the actual depth. It is just an approximate indication. Judge the depth by actual work.

Turn the up-down handle to adjust the tine depth.

1. Apply the parking brake of the tractor, and stop the engine.
2. Loosen the right and left roller holding fixtures.

3. Turn the right and left up-down handles to adjust the tine depth.
 - Turn the handle clockwise to increase the coring depth. (The roller rises and the frame lowers.)
 - Turn the handle counterclockwise to decrease the coring depth. (The roller lowers and the frame rises.)

Note:

Making the up-down handle one turn increases/decreases the tine depth about 4 mm (0.16 in).

Adjust the depth referring the depth gauge and the scale decal provided on both sides of the attachment.

One scale corresponds to 10 mm (0.39 in). When the tip of the depth gauge is at the uppermost edge of the scale, it shows the maximum depth of standard tine.

4. Tighten the right and left roller holding fixtures.

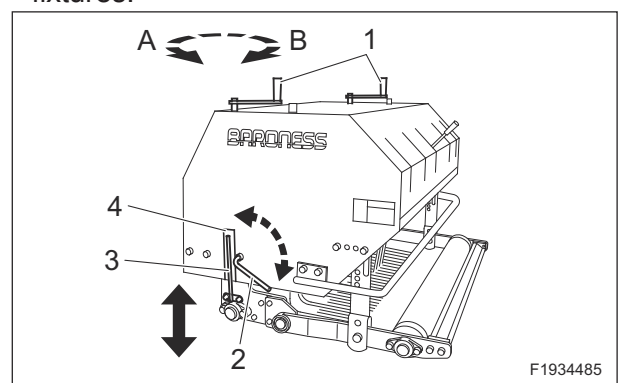

Adjustment of Tine Depth_001

1	Up-down handle
2	Roller holding fixture
3	Depth gauge
4	Scale decal
A	Shallow
B	Deep

Maintenance

Replacement

Change of Tines

Caution

Wear gloves when touching tines to avoid cutting your hands.

Important

Replace all tines at the same time. Mixing new and old tines may cause abnormal vibration.

1. Stop the tractor's engine.
2. Loosen the bolts.
3. Remove the old tine.
4. Fully insert the new tine into the hole in the tine mount.
5. While holding the tine with your hand, firmly tighten the bolts.
6. Check that the tine does not fall out.

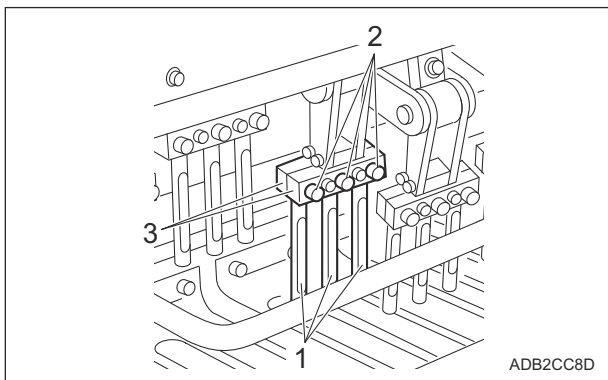

Change of Tines_001

1	Tine
2	Bolt
3	Tine mount

Note:

Use the optional tine mount to aerate with a finer pitch.

Important

Select and use appropriate tine mounts and lawn pressing plates according to the tines to be used.

Follow the steps below to install the tine mount and tines.

1. Secure the tine mount to the tine mount holder with the hex socket head bolts A.

2. Fully insert the tine into the hole in the tine mount.
3. While holding the tine in place with your hand, firmly tighten the hex socket head bolts B.
4. Check that the tine does not fall out.

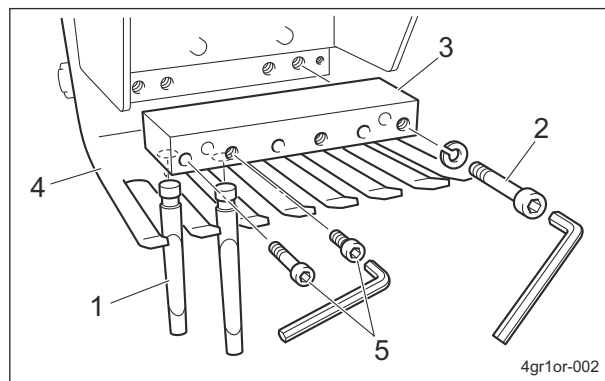

Change of Tines_002

1	Tine
2	Bolt w/hexagon hole A
3	Tine mount
4	Specialized lawn pressing plate
5	Bolt w/hexagon hole B

Change of Gear Oil

Caution

Be careful with hot oil, which could cause burns if it contacts your skin.

Important

When you change the gear oil, be sure to drain it into a container and discard it in accordance with local laws and regulations.

Important

If the gear oil emulsifies or if it becomes even slightly less transparent, change the oil immediately.

Important

Use BONNOC TS680 (or equivalent) as gear oil.

1. Follow the steps below to remove the old oil.
 - [1] Remove the drain plug, and then drain the old oil into a container.

[2] Install the drain plug.

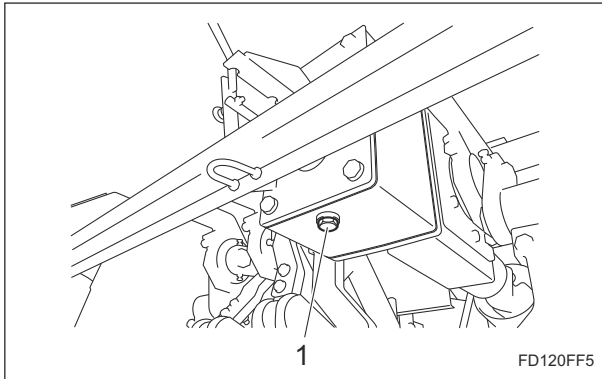

Change of Gear Oil_001

1	Drain plug
---	------------

2. Follow the steps below to supply new oil.

[1] Open the oil filler cap, supply gear oil through the oil filling port until the oil level reaches the middle of the oil gauge. The gear box capacity is approximately 3.8 dm³ (3.8 L).

[2] Tighten the oil filler cap securely.

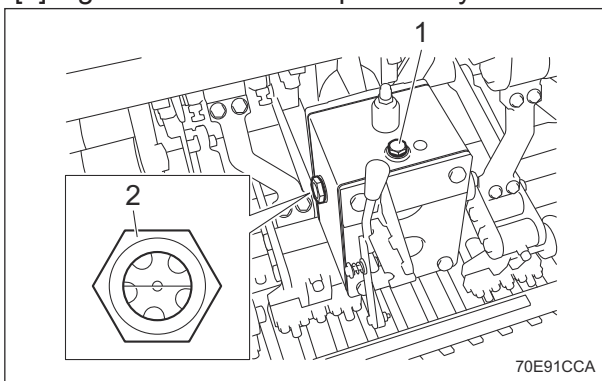

Change of Gear Oil_002

1	Oil filler cap
2	Oil gauge

3. On a level surface, check the oil level is at the middle of the oil gauge. If necessary, supply oil.
4. Check underneath the machine for oil leakage.

Storage

Long-Term Storage

Follow the instructions below for long-term storage of this attachment.

1. Cleaning

- Remove any dirt, grass, debris, or oil stains completely.

2. Lubrication

- Supply oil and apply grease to appropriate parts.

3. Storage location

- Cover the machine and store it in a dry place where it will not be exposed to rain.
- As for storage of the attachment detached from the tractor, place it on a flat surface.

Maintenance

Appended Table

Tightening TorquesPage 7-2
 Standard Tightening TorquesPage 7-2
 Principal Tightening Torques Page 7-4

Daily Check List Page 7-7

Maintenance Schedule Page 7-8

Crank Timing DiagramPage 7-8

Crank Timing DiagramPage 7-9

Appended Table

Tightening Torques

Important

Refer to the Tightening Torque table.
Note that the Baroness product warranty may not apply to defects caused by incorrect or overtorque tightening, etc.

Standard Tightening Torques

Bolts and Nuts



Important

A number of bolts are used in each part of this machine.
Be sure to re-tighten the bolts and nuts, because they may be loosened at the earlier stage of the use.

- As to the bolts and nuts without any special instruction, tighten them in appropriate tightening torque with proper tool.
Too much tightening may cause the looseness or damage of the screw.
- The strength of tightening is determined by types of screws, strength, the friction of thread face or base face and others.
The table below is for the galvanized or parkerized bolts.
In case that the strength of internal thread is weak, it is not applied.
- Do not use rusty or sand attached "screw."
Otherwise, it may cause insufficient tightening even if you apply the specified tightening torque.
The friction of the screw face becomes higher and the tightening torque is canceled out by the friction, therefore sufficient tightening cannot be applied.
- If "screw" is wet by water or oil, do not tighten it with normal tightening torque.
If the screw is wet, the torque coefficient will get smaller and it may result in too much tightening.
Too much tightening may cause looseness by the screw stretched or result in damage.
- Do not use a bolt experienced too much burden.
- Using the impact wrench requires the skill.
Do exercise as much as possible for steady tightening.

Appended Table

Nominal diameter	General bolt		
	Strength classification 4.8		
	 tib3yb-001		
	N-m	kgf-cm	lb-in
M5	3 - 5	30.59 - 50.99	26.55 - 44.26
M6	7 - 9	71.38 - 91.77	61.96 - 79.66
M8	14 - 19	142.76 - 193.74	123.91 - 168.17
M10	29 - 38	295.71 - 387.49	256.68 - 336.34
M12	52 - 67	530.24 - 683.20	460.25 - 593.02
M14	70 - 94	713.79 - 958.52	619.57 - 831.99
M16	88 - 112	897.34 - 1142.06	778.89 - 991.31
M18	116 - 144	1,182.85 - 1,468.37	1,026.72 - 1,274.54
M20	147 - 183	1,498.96 - 1,866.05	1,301.10 - 1,619.73
M22	295	3,008.12	2,611.05
M24	370	3,772.89	3,274.87
M27	550	5,608.35	4,868.05
M30	740	7,545.78	6,549.74

Nominal diameter	Heat-treated bolt					
	Strength classification 8.8			Strength classification 10.9		
	 tib3yb-002			 tib3yb-003		
	N-m	kgf-cm	lb-in	N-m	kgf-cm	lb-in
M5	5 - 7	50.99 - 71.38	44.26 - 61.96	7 - 10	71.38 - 101.97	61.96 - 88.51
M6	8 - 11	81.58 - 112.17	70.81 - 97.36	14 - 18	142.76 - 183.55	123.91 - 159.32
M8	23 - 29	234.53 - 295.71	203.57 - 256.68	28 - 38	285.52 - 387.49	247.83 - 336.34
M10	45 - 57	458.87 - 581.23	398.30 - 504.51	58 - 76	591.43 - 774.97	513.36 - 672.68
M12	67 - 85	683.20 - 866.75	593.02 - 752.34	104 - 134	1,060.49 - 1,366.40	920.50 - 1186.03
M14	106 - 134	1,080.88 - 1,366.40	938.21 - 1,186.03	140 - 188	1,427.58 - 1,917.04	1,239.14 - 1,663.99
M16	152 - 188	1,549.94 - 1,917.04	1,345.35 - 1,663.99	210 - 260	2,141.37 - 2,651.22	1,858.71 - 2,301.26
M18	200 - 240	2,039.40 - 2,447.28	1,770.20 - 2,124.24	280 - 340	2,855.16 - 3,466.98	2,478.28 - 3,009.34
M20	245 - 295	2,498.27 - 3,008.12	2,168.50 - 2,611.05	370 - 450	3,772.89 - 4,588.65	3,274.87 - 3,982.95
M22	-	-	-	530	5,404.41	4,691.03
M24	-	-	-	670	6,831.99	5,930.17
M27	-	-	-	1,000	10,197.00	8,851.00
M30	-	-	-	1,340	13,663.98	11,860.34

Note:
The same values are applied to "fine screw thread."

Appended Table

Principal Tightening Torques

Tightening Torque by Model (TDA1200)

TDA1200

Tighten the following bolts and nuts at the torque specified in the table.

For thread locking adhesive, apply a middle strength thread locker (ThreeBond 1322 or equivalent anaerobic sealant).

Location	Code	Part name	Tightening torque			Thread locking adhesive
			N-m	kgf-cm	lb-in	
Frame & Cover	K0013161201	BOLT, HT M16-120	210 - 260	2,141.37 - 2,651.22	1,858.71 - 2,301.26	-
	K0013160952	BOLT, HT M16-95	210 - 260	2,141.37 - 2,651.22	1,858.71 - 2,301.26	-
	K0013160601	BOLT, HT M16-60	210 - 260	2,141.37 - 2,651.22	1,858.71 - 2,301.26	-
	K0010120302	BOLT, HT M12-30	104 - 134	1,060.49 - 1,366.40	920.50 - 1,186.03	-
Front & Rear Rollers	K0071000372	BOLT, FOR HYDRAULIC MOTOR	52 - 67	530.24 - 683.20	460.25 - 593.02	-
	K0010120402	BOLT, HT M12-40	104 - 134	1,060.49 - 1,366.40	920.50 - 1,186.03	-
	K0010100252	BOLT, HT M10-25	58 - 76	591.43 - 774.97	513.36 - 672.68	-
	K0010140302	BOLT, HT M14-30	70 - 94	713.79 - 958.52	619.57 - 831.99	-
	K0013140452	BOLT, HT M14-45	70 - 94	713.79 - 958.52	619.57 - 831.99	-
Gear Box	K0013121002	BOLT, HT M12-100	104 - 134	1,060.49 - 1,366.40	920.50 - 1,186.03	-
Crank	K0013140502	BOLT, HT M14-50	140 - 188	1,427.58 - 1,917.04	1,239.14 - 1,663.99	-
	K0013120702	BOLT, HT M12-70	104 - 134	1,060.49 - 1,366.40	920.50 - 1,186.03	-
	TDA12000362Z8	NUT, 20 A	300 - 350	3,059.10 - 3,568.95	2,655.30 - 3,097.85	-
	TDA12000370Z8	NUT, 24 B	300 - 350	3,059.10 - 3,568.95	2,655.30 - 3,097.85	-
	K0010120602	BOLT, HT M12-60	104 - 134	1,060.49 - 1,366.40	920.50 - 1,186.03	-
	K0013140452	BOLT, HT M14-45	140 - 188	1,427.58 - 1,917.04	1,239.14 - 1,663.99	-
	K0145140002	NUT, W/F- RING M14 P1.5	140 - 188	1,427.58 - 1,917.04	1,239.14 - 1,663.99	-
	K0010120502	BOLT, HT M12-50	104 - 134	1,060.49 - 1,366.40	920.50 - 1,186.03	-

Appended Table

Location	Code	Part name	Tightening torque			Thread locking adhesive
			N-m	kgf-cm	lb-in	
Crank	K0010100602	BOLT, HT M10-60	58 - 76	591.43 - 774.97	513.36 - 672.68	-
	K001A100251	BOLT, 13T W/HEX HOLE M10-25	29 - 38	295.71 - 387.49	256.68 - 336.34	-
	K0010100402	BOLT, HT M10-40	29 - 38	295.71 - 387.49	256.68 - 336.34	-
Tine (Option)	K0013101302	BOLT, HT M10-130	29 - 38	295.71 - 387.49	256.68 - 336.34	-
	K0060080150	BOLT, SUS W/HEX HOLE M8-15	14 - 19	142.76 - 193.74	123.91 - 168.17	-
	K0060100800	BOLT, SUS W/HEX HOLE M10-80	29 - 38	295.71 - 387.49	256.68 - 336.34	-
	K0060080150	BOLT, SUS W/HEX HOLE M8-15	14 - 19	142.76 - 193.74	123.91 - 168.17	-
	K0010100402	BOLT, HT M10-40	29 - 38	295.71 - 387.49	256.68 - 336.34	-

Appended Table

Tightening Torque by Model (TDA1600)

TDA1600

Tighten the following bolts and nuts at the torque specified in the table.

For thread locking adhesive, apply a middle strength thread locker (ThreeBond 1322 or equivalent anaerobic sealant).

Location	Code	Part name	Tightening torque			Thread locking adhesive
			N-m	kgf-cm	lb-in	
Frame & Cover	K0013161201	BOLT, HT M16-120	210 - 260	2,141.37 - 2,651.22	1,858.71 - 2,301.26	-
	K0013160952	BOLT, HT M16-95	210 - 260	2,141.37 - 2,651.22	1,858.71 - 2,301.26	-
	K0013160601	BOLT, HT M16-60	210 - 260	2,141.37 - 2,651.22	1,858.71 - 2,301.26	-
	K0010120302	BOLT, HT M12-30	104 - 134	1,060.49 - 1,366.40	920.50 - 1,186.03	-
Front & Rear Rollers	K0071000372	BOLT, FOR HYDRAULIC MOTOR	52 - 67	530.24 - 683.20	460.25 - 593.02	-
	K0010140302	BOLT, HT M14-30	70 - 94	713.79 - 958.52	619.57 - 831.99	-
	K0013140452	BOLT, HT M14-45	70 - 94	713.79 - 958.52	619.57 - 831.99	-
	K0010120402	BOLT, HT M12-40	104 - 134	1,060.49 - 1,366.40	920.50 - 1,186.03	-
	K0010100252	BOLT, HT M10-25	58 - 76	591.43 - 774.97	513.36 - 672.68	-
Gear Box	K0013121002	BOLT, HT M12-100	104 - 134	1,060.49 - 1,366.40	920.50 - 1,186.03	-
Crank	K0013140502	BOLT, HT M14-50	140 - 188	1,427.58 - 1,917.04	1,239.14 - 1,663.99	-
	K0013120702	BOLT, HT M12-70	104 - 134	1,060.49 - 1,366.40	920.50 - 1,186.03	-
	TDA12000370Z8	NUT, 24 B	300 - 350	3,059.10 - 3,568.95	2,655.30 - 3,097.85	-
	K0010120602	BOLT, HT M12-60	104 - 134	1,060.49 - 1,366.40	920.50 - 1,186.03	-
	K0013140452	BOLT, HT M14-45	140 - 188	1,427.58 - 1,917.04	1,239.14 - 1,663.99	-
	K0145140002	NUT, W/F- RING M14 P1.5	140 - 188	1,427.58 - 1,917.04	1,239.14 - 1,663.99	-
	K0010100602	BOLT, HT M10-60	58 - 76	591.43 - 774.97	513.36 - 672.68	-
	K0013100902	BOLT, HT M10-90	58 - 76	591.43 - 774.97	513.36 - 672.68	-
	K0010100402	BOLT, HT M10-40	29 - 38	295.71 - 387.49	256.68 - 336.34	-

Appended Table

Location	Code	Part name	Tightening torque			Thread locking adhesive
			N-m	kgf-cm	lb-in	
Crank	K0010120502	BOLT, HT M12-50	104 - 134	1,060.49 - 1,366.40	920.50 - 1,186.03	-
Tine (Option)	K0013101302	BOLT, HT M10-130	29 - 38	295.71 - 387.49	256.68 - 336.34	-
	K0060080150	BOLT, SUS W/HEX HOLE M8-15	14 - 19	142.76 - 193.74	123.91 - 168.17	-
	K0060100800	BOLT, SUS W/HEX HOLE M10-80	29 - 38	295.71 - 387.49	256.68 - 336.34	-
	K0060080150	BOLT, SUS W/HEX HOLE M8-15	14 - 19	142.76 - 193.74	123.91 - 168.17	-
	K0010100402	BOLT, HT M10-40	29 - 38	295.71 - 387.49	256.68 - 336.34	-

Daily Check List

TDA1200/TDA1600

- . . . Inspect, adjust, supply, clean (first time)
- . . . Inspect, adjust, supply, clean
- ▲ . . . Replace (first time)
- △ . . . Replace

Maintenance Item	Before Work	After Work	Remarks
Check tine	○		
Check lawn pressing plate	○		
Check spring box	○		
Check cover	○		
Check roller	○		
Check gear oil	○		
Check universal joint	○		
Check bolts and nuts	○		
Check liquid leakage	○		
Check machine exterior	○		
Clean vertical aeration section		○	
Clean machine exterior		○	

Appended Table

Maintenance Schedule

TDA1200/TDA1600

- · · · Inspect, adjust, supply, clean (first time)
- · · · Inspect, adjust, supply, clean
- ▲ · · · Replace (first time)
- △ · · · Replace

Maintenance Item	Before Work	After Work	Every 50 hrs.	Every 100 hrs.	Every 300 hrs.	When Required	Remarks
Check tine depth	○						
Lubricate with grease			○				
Adjust tine depth						○	
Change gear oil				▲	△		

· The values for consumables are not guaranteed.

Crank Timing Diagram

TDA1200

Respective crank metal fittings are attached in a 60-degree turned state to ensure right timing.

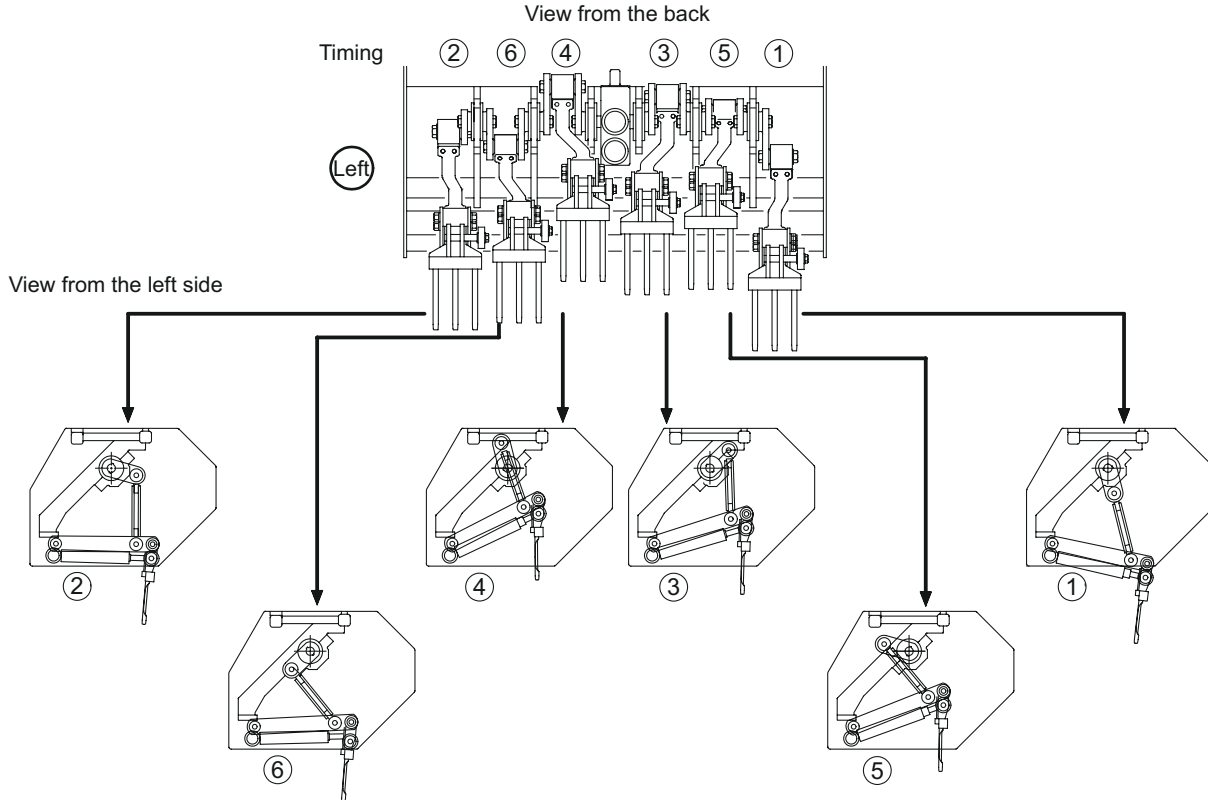

35gcfm-001

Crank Timing Diagram_001

Crank Timing Diagram

TDA1600

Respective crank metal fittings are attached in a 45-degree turned state to ensure right timing.

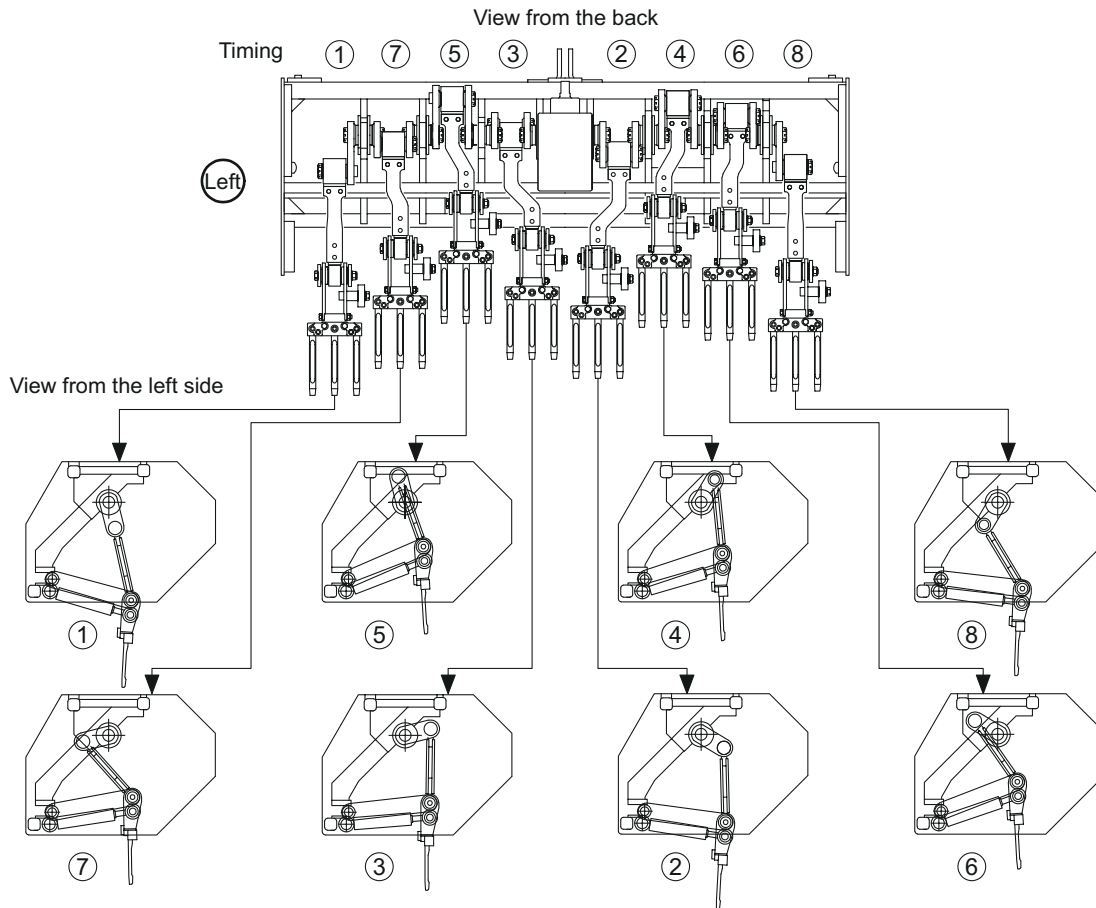

Crank Timing Diagram_001

35gcfm-002

Appended Table

Appended Table

Daily Check Records Page 8-2

Maintenance RecordsPage 8-3

Records

Daily Check Records

TDA1200/TDA1600

Use this table freely for your records of the daily check.

Model						Serial Number					
Items											
Check tire											
Check lawn pressing plate											
Check spring box											
Check cover											
Check roller											
Check gear oil											
Check universal joint											
Check bolts and nuts											
Check liquid leakage											
Check machine exterior											
Clean vertical aeration section											
Clean machine exterior											

Maintenance Records

TDA1200/TDA1600

Use this table freely for your records of the maintenance.

Model					Serial Number					
Items										
Check tine depth										
Lubricate with grease										
Adjust tine depth										
Change gear oil										

Records

Records

BARONESS[®]
Quality on Demand

 **KYOEISHA CO., LTD.**
Head Office 1-26, Miyuki-cho, Toyokawa-city, Tel :+81-533-84-1390
Aichi-pref, 442-8530 JAPAN Fax:+81-533-84-1220