

TR50

EZ Carry

Owner's Operating Manual

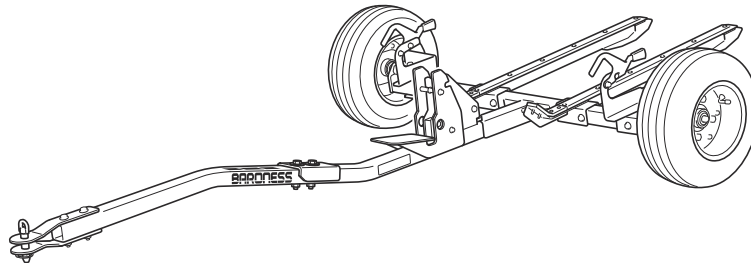

Serial No. TR50 : 10376-

"Required reading"
Read this manual before using the machine.

BARONNESS[®]
Quality on Demand

Ver.1.5

Greeting

Thank you for purchasing the Baroness product. This manual describes the proper handling, adjustment, and inspection of your product. We hope you will use the product safely, and take advantage of its best performance.

QR Code

(*QR Code is a registered trademark of DENSO WAVE INCORPORATED.)

A QR code label is affixed on the machine.

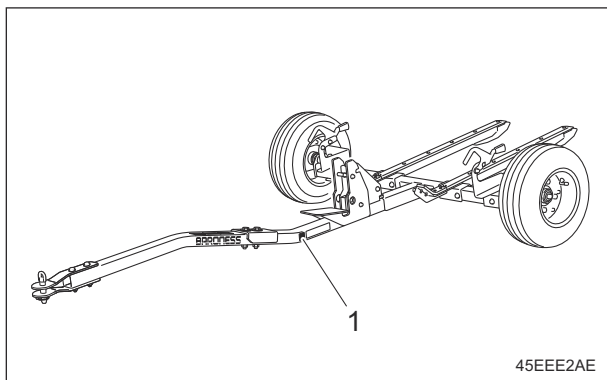

QR Code_001

1	QR code label
---	---------------

Scan the QR code with your smartphone for easy access to Baroness Manual Reference Service where you can browse Owner's Operating Manual and Parts Catalog.
<https://doc.baroness-international.com/manuals/TR50>



QR Code_002

Read this manual carefully to ensure that you thoroughly understand how to properly operate and maintain the product, and to avoid causing injury to yourself or others.

The operator is responsible for operating the product properly and safely.

Maintenance service for this machine should be performed by a mechanic with expertise.

If you have any questions concerning maintenance or genuine parts, please contact a Baroness dealer or Kyoisha.





When making inquiries about your product, please specify the model and serial number.

When loaning or transferring the product, please also provide this manual together with the product.

Kyoisha Co., Ltd.

Warning Symbols

This manual uses the following warning symbols for handling precautions that are important for your safety.

 <p style="text-align: center;">696cq5-001</p>	<p>Warning symbol</p>
<p>This symbol indicates the articles regarding “Danger,” “Warning,” or “Caution.” Those articles describe important safety precautions and so read them carefully to understand completely before operating the machine. Failure to adequately follow these safety precautions may cause an accident.</p>	
<p> Danger This symbol indicates that serious injury or death will occur if the warning is ignored.</p> <p> Warning This symbol indicates that serious injury or death may occur if the warning is ignored.</p> <p> Caution This symbol indicates that injury or damage to property may occur if the warning is ignored.</p> <p>Important This symbol indicates precautions on the mechanism of the machine.</p>	

Introduction

Precautionary Statement

 Caution

The information described in this manual is subject to change for improvement without prior notice.

When replacing parts, be sure to use genuine Baroness parts or parts designated by Kyo-eisha.

Note that the Baroness product warranty may not apply to defects caused by the use of parts from other companies.

Prior to use, carefully read the following manuals to thoroughly understand the contents for safe and correct operation.

- Baroness Owner's Operating Manual

Purpose

This machine is intended for transporting Baroness walk behind reel mower.

(LM18/56/66/101 series)

Do not use this machine in any way other than its intended purpose, and do not modify the machine.

Operating this machine for other purposes and modifying it may be very dangerous and may cause damage to the machine.

In addition, do not use this machine on public roads.

Safety	Page 1-1	Daily Check Records	Page 9-2
Safe Operating Practices	Page 1-2	Maintenance Records	Page 9-3
Disposal	Page 2-1		
Recycle and Waste Disposal	Page 2-2		
Product Overview	Page 3-1		
Specifications	Page 3-2		
Names of Each Section	Page 3-3		
Regulation Decals	Page 3-4		
Safety Signs and Instruction Signs	Page 3-5		
Description of Functions	Page 4-1		
Pedal	Page 4-2		
Axle Lock Lever	Page 4-2		
Drum Shaft Lock Lever	Page 4-2		
Mower Tire Lock Lever	Page 4-3		
Handling Instructions	Page 5-1		
Preparation for Use	Page 5-2		
Inspection before Use	Page 5-6		
Move	Page 5-7		
Loading and Unloading	Page 5-9		
Towing	Page 5-10		
Transporting	Page 5-10		
Storage	Page 5-11		
Maintenance	Page 6-1		
Precautions for Maintenance	Page 6-2		
Lubrication	Page 6-2		
Adjustment	Page 6-4		
Replacement	Page 6-8		
Storage	Page 6-8		
Repair	Page 7-1		
Precautions for Repair	Page 7-2		
Adjustment	Page 7-2		
Appended Table	Page 8-1		
Tightening Torques	Page 8-2		
Daily Check List	Page 8-4		
Maintenance Schedule	Page 8-5		
List of Adjusted Value	Page 8-5		
Records	Page 9-1		

TR50

Contents

Safe Operating Practices Page 1-2

Training Page 1-2

Preparation Page 1-2

Operation Page 1-2

Maintenance Page 1-2

Towing Page 1-2



Safety

Failure to adequately follow these safety precautions may cause an accident resulting in injury or death.

Danger

This product is designed to ensure safe operation and has been tested and inspected thoroughly before shipment from the factory. The product is equipped with safety devices to prevent accidents.

However, whether the product demonstrates its original performance level depends on the manner in which it is operated and handled, as well as the manner in which it is managed on a daily basis.

Inappropriate use or management of the product may result in injury or death.

Observe the following safety instructions to ensure safe operation.

Safe Operating Practices

Training

1. Read this manual and other training material carefully.
Be familiar with the controls, safety signs, and the proper use of the equipment.
2. If the operator or mechanic can not read the language used in this manual, it is the owner's responsibility to explain this material to them.
3. All operators and mechanics should seek and obtain professional and practical instruction.
The owner is responsible for training the users.
4. Never allow people unfamiliar with these instructions to use or service the machine.
5. The owner/user can prevent and is responsible for accidents or injuries occurring to themselves, other people, or property.
6. Keep in mind that the owner, operator, and mechanic are responsible for accidents or hazards occurring to other people or their property.
7. You can find additional safety information where needed throughout this manual.
8. Determine the left and right sides of the machine from the normal operating position.

Preparation

1. Evaluate the terrain to determine what accessories and attachments are needed to properly and safely perform the job.
Only use accessories and attachments approved by the manufacturer.
2. Inspect the area where the equipment is to be used and remove all objects such as rocks, toys and wire which can be thrown by the machine.

Operation

1. Take care when loading or unloading the machine into a trailer or a truck.
Load or unload the machine in a flat and safe place.
Before loading or unloading, set the parking brake on the truck or trailer, stop the engine, and chock the wheels.
Fasten the machine to the truck with a rope or other suitable restraining device that has sufficient strength.
When using a running board, select one with sufficient strength, length, and width and that will not cause the machine to slip.

Maintenance

1. Never allow untrained personnel to service machine.
2. Stop the machine on level ground for repairing, adjusting or cleaning.
3. Appropriately manage and correctly use the tools necessary for servicing or adjusting the machine.
4. Keep all parts in good working condition and all hardware tightened.
Replace all worn or damaged decals.
5. Keep all nuts, bolts and screws tight to be sure the equipment is in safe working condition.
6. Carefully release pressure from components with stored energy.

Towing

1. Follow the manufacturer's recommendation for weight limits for towed equipment and towing on slopes.

Recycle and Waste Disposal Page 2-2

About RecyclePage 2-2

About Waste Disposal Page 2-2

Disposal

Disposal

Recycle and Waste Disposal

About Recycle

Recycling battery etc. is recommended for environmental conservation and economical use of resources.

It may be required by local laws.

About Waste Disposal

Make sure that waste generated when servicing or repairing the machine is disposed of in accordance with local regulations. (e.g. waste oil, antifreeze, rubber products, and wires etc.)

Specifications Page 3-2

SpecificationsPage 3-2

Names of Each Section Page 3-3**Regulation DecalsPage 3-4**

Positions of Regulation Decals Page 3-4

Description of Regulation Decals Page 3-4

Safety Signs and Instruction Signs Page 3-5

About Safety Signs and Instruction

SignsPage 3-5

Positions of Safety Decals and

Instruction Decals Page 3-5

Description of Safety Decals and

Instruction Decals Page 3-5

Product Overview

Specifications

Specifications

Model		TR50			
Name		EZ Carry			
Type (Loading method)		Mower drums		Mower tires	
Dimensions	Total length	266 cm	104.72 in	273 cm	107.48 in
	Total width	18" mower	138 cm	54.33 in	←
		22" mower	147 cm	57.87 in	←
		26" mower	157 cm	61.81 in	←
Total height	Tire	41 cm	16.14 in	←	←
Weight		58 kg	127.87 lb	69 kg	152.12 lb
Maximum inclination for operation		15 degrees		←	
Tire size		16 x 6.50-8		←	
Tire pneumatic pressure		200 kPa (2.0 kgf/cm ²)	29 psi	←	←
Applicable towing vehicle	Towing capacity	200 kg or more	440.92 lb or more	←	←

Product Overview

Names of Each Section

TR50 (Loading method : Mower drums)

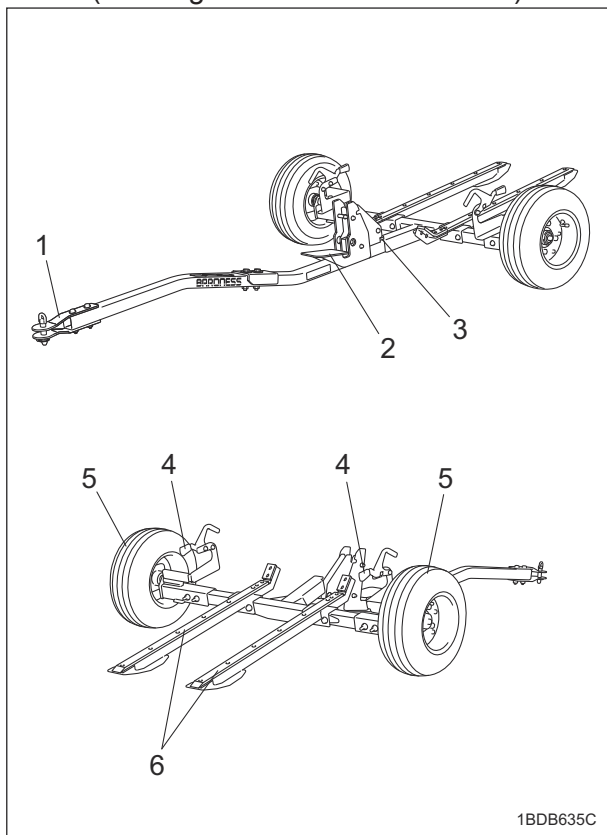

Names of Each Section_001

1	Hitch
2	Pedal
3	Axle lock lever
4	Drum shaft lock lever
5	Tire
6	Tilting table

TR50 (Loading method : Mower tires)

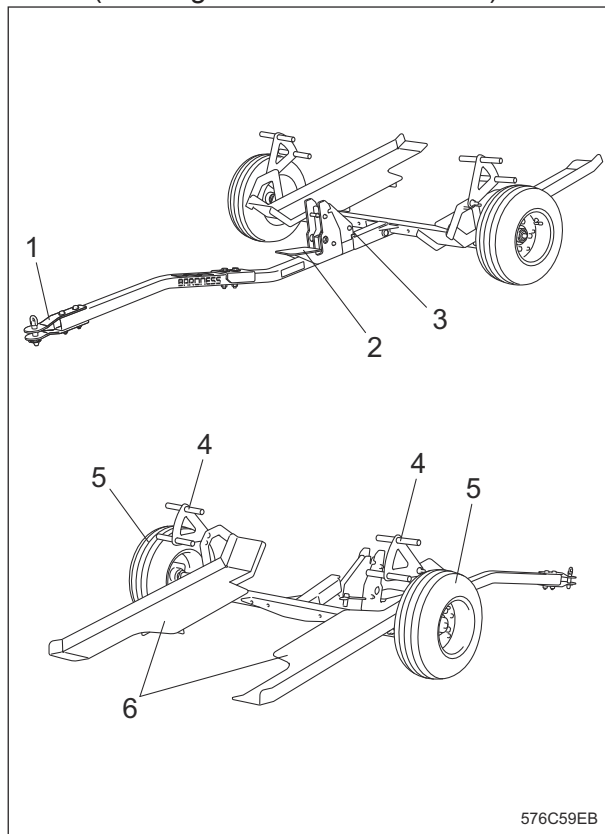

Names of Each Section_002

1	Hitch
2	Pedal
3	Axle lock lever
4	Mower tire lock lever
5	Tire
6	Tilting table

Product Overview

Product Overview

Regulation Decals

Positions of Regulation Decals

TR50 (Loading method : Mower drums)

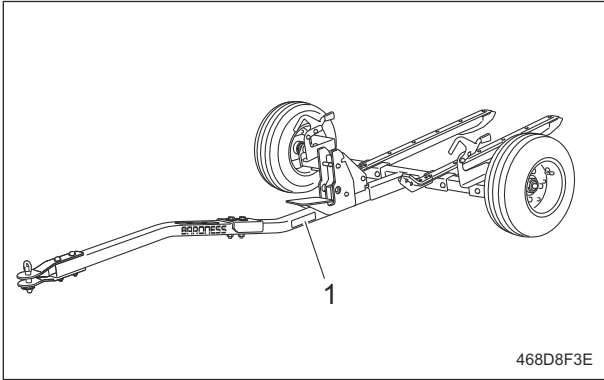

Positions of Regulation Decals_001

1	Serial number plate
---	---------------------

TR50 (Loading method : Mower tires)

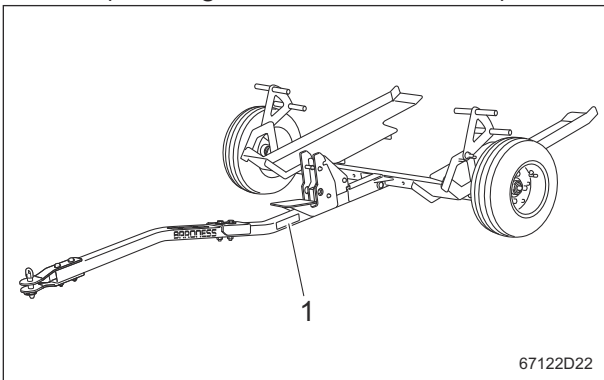

Positions of Regulation Decals_002

1	Serial number plate
---	---------------------

Description of Regulation Decals

Serial Number Plate

The following information is written on the serial number plate.

1. Model
2. Serial number
3. Registered trademark
4. Manufacturer

- Company name
- Postal address/Address
- Website

Contact the manufacturer via the contact form on the website.



Serial Number Plate_001

Safety Signs and Instruction Signs

About Safety Signs and Instruction Signs

Important

Safety decals and instruction decals are attached to this product. Make sure that they are preserved in their entirety. If they are damaged, become dirty, or peel off, replace them with new ones.

Part numbers for decals that need to be replaced are listed in the parts catalog. Order them from a Baroness dealer or Kyoeisha.

Positions of Safety Decals and Instruction Decals

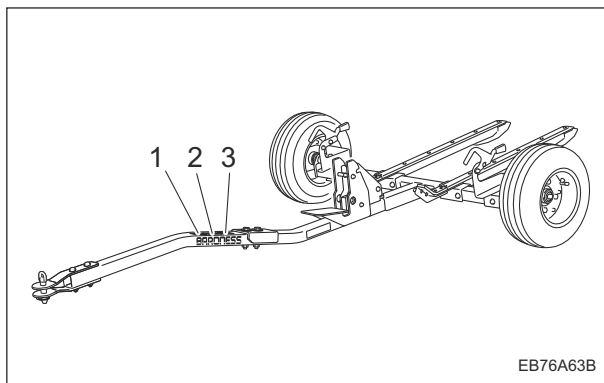

Positions of Safety Decals and Instruction Decals_001

1	DECAL, READ OWNERS MANUAL
2	DECAL, ATTENTION AT SLOPE
3	DECAL, PROHIBITED TO RIDE ON

Description of Safety Decals and Instruction Decals

Decal on Reading Owner's Operating Manual

K4205002160

Decal, read Owner's Operating Manual

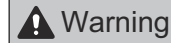

Read the Owner's Operating Manual.

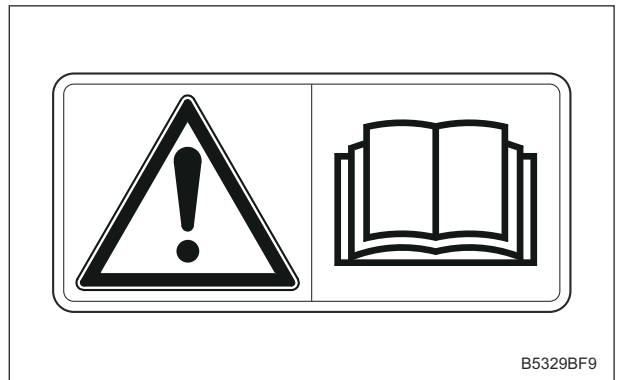

B5329BF9

Decal on Reading Owner's Operating Manual_001

Caution Slope Decal

K4205002170

Decal, caution slope

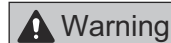

Rollover - Never travel on slopes of 15 degrees or more. Otherwise, there is a possibility of rollover. When you descend a slope, drive at low speed.

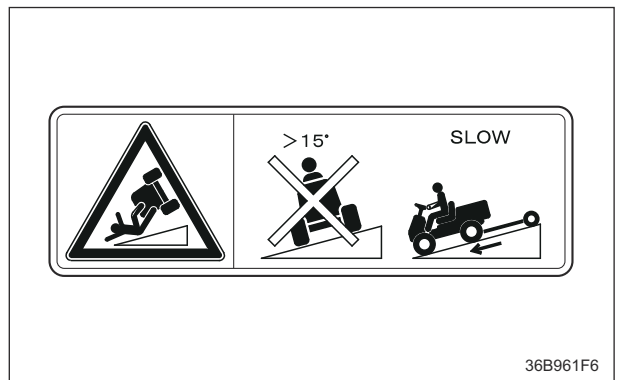

36B961F6

Caution Slope Decal_001

Product Overview

Prohibited Ride Decal

K4205002180

Decal, prohibited to ride on

 Caution

Never allow a person to ride on the trailer while traveling. Otherwise, the person may fall and get injured.

Do not load and transport any machine other than the Baroness walk-behind reel mower series LM18/56/66/101.



Prohibited Ride Decal_001

Description of Functions

Pedal Page 4-2

Axle Lock Lever Page 4-2

Drum Shaft Lock Lever Page 4-2

Mower Tire Lock Lever Page 4-3

Description of Functions

Pedal

The pedal is used to release the connection between the greens mower stand stay and the pedal hooks of the mower trailer.

To release the connection between the greens mower stand stay and the pedal hooks of the mower trailer, depress the pedal to set it to the "Release" position.

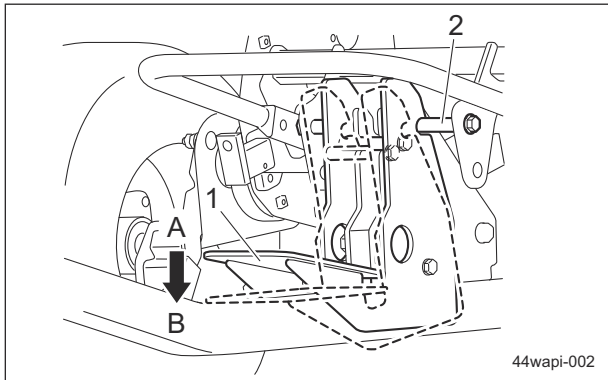

Pedal_001

1	Pedal
2	Stand stay
A	Lock
B	Release

Axle Lock Lever

The axle lock lever secures the angle of the tilting tables.

When loading the greens mower onto the mower trailer for towing, set the lever to the "Lock" position.

When unloading the greens mower from the mower trailer, set the lever to the "Release" position.

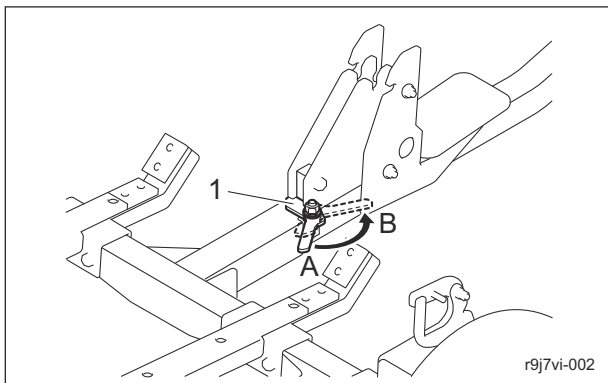

Axle Lock Lever_001

1	Axle lock lever
A	Lock
B	Release

Drum Shaft Lock Lever

The drum shaft lock lever is the function for drum loading type.

The drum shaft lock lever prevents the greens mower from falling from the mower trailer.

When loading the greens mower onto the mower trailer for towing, set the drum shaft lock lever to the "Lock" position.

When unloading the greens mower from the mower trailer, set the drum shaft lock lever to the "Release" position.

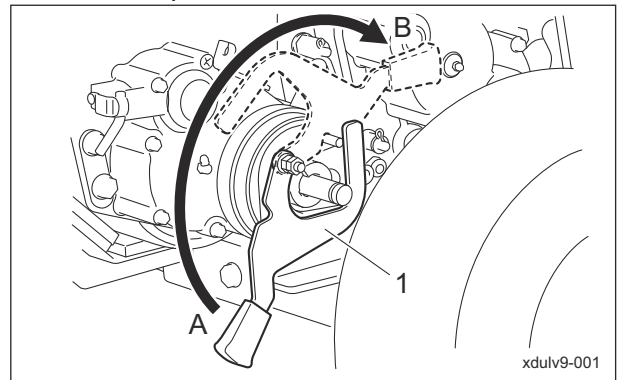

Drum Shaft Lock Lever_001

1	Drum shaft lock lever
A	Lock
B	Release

Mower Tire Lock Lever

The mower tire lock lever is the function for tire loading type.

The mower tire lock lever prevents the greens mower from falling from the mower trailer.

When loading the greens mower onto the mower trailer for towing, set the mower tire lock lever to the "Lock" position.

When unloading the greens mower from the mower trailer, set the mower tire lock lever to the "Release" position.

Mower tire lock lever (TR50---0511ZD)

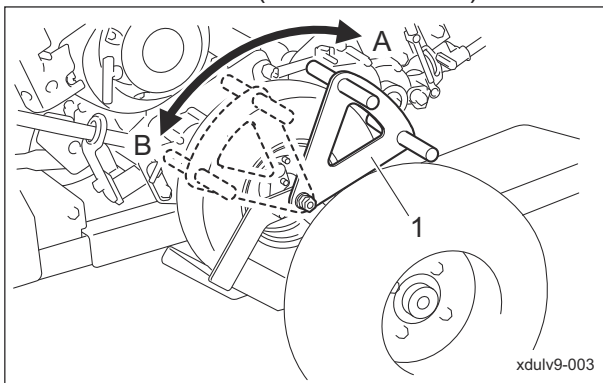

Mower Tire Lock Lever_001

Mower tire lock lever (TR50---0514ZD)

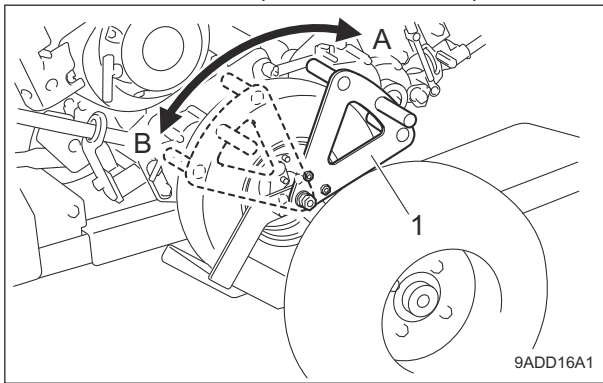

Mower Tire Lock Lever_002

1	Mower tire lock lever
A	Lock
B	Release

Description of Functions

Preparation for Use Page 5-2

Assembling Towing Section Page 5-2

Connection between Axle Section
and Tilting Tables Page 5-2

Connection between Towing Section
and Axle Section Page 5-3

Installation of Greens Mower Fixture Page 5-4

Inspection before Use Page 5-6

Tire Page 5-6

Hitch Page 5-6

Stay Page 5-7

Pedal Hook Page 5-7

Bolts and Nuts Page 5-7

Move Page 5-7

Traveling Procedure Page 5-7

Precautions for Connecting the
Mower Trailer Page 5-8

Procedure to Connect to The Mower
Trailer Page 5-8

Loading and Unloading Page 5-9

Loading Procedure of Greens Mower Page 5-9

Unloading Procedure of Greens
Mower Page 5-9

Towing Page 5-10

Precautions for Towing Page 5-10

Towing Procedure Page 5-10

Transporting Page 5-10

Transporting Procedure Page 5-10

Storage Page 5-11

Short-Term Storage Page 5-11

Handling Instructions

Preparation for Use

Assembling Towing Section

1. Attach the pedal hook to the rear traction bar.

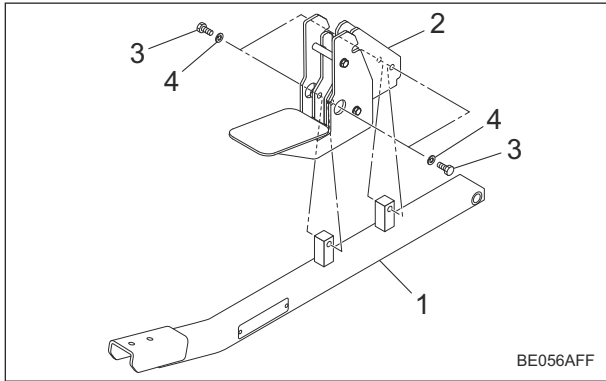

Assembling Towing Section_001

1	Rear traction bar
2	Pedal hook
3	Bolt
4	Spring washer

2. Align the holes of front and rear traction bars.
3. Install the bolts to the aligned holes on the traction bars and fix them with the nuts.

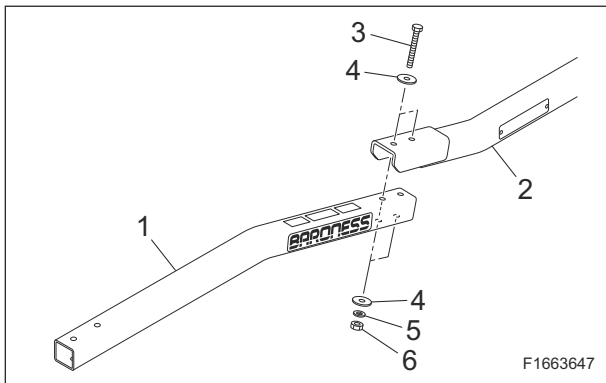

Assembling Towing Section_002

1	Front traction bar
2	Rear traction bar
3	Bolt
4	Washer
5	Spring washer
6	Nut

Connection between Axle Section and Tilting Tables

Connection between Axle Unit and Tilting Tables (Drum Loading Type)

1. Fit the tilting tables onto the axle unit.
2. Align the holes in the tilting tables and axle unit.

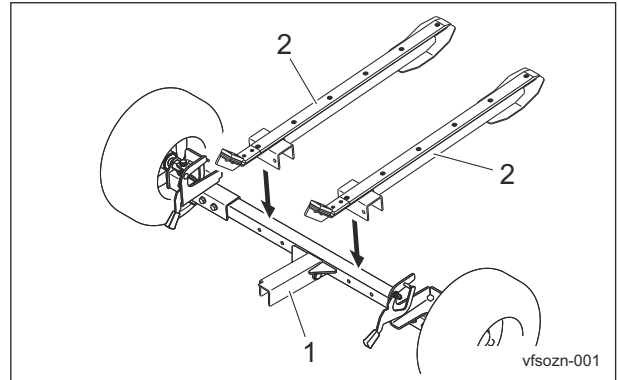

Connection between Axle Unit and Tilting Tables (Drum Loading Type)_001

1	Axle unit
2	Tilting table

3. Install the bolts to secure the axle unit and tilting tables.

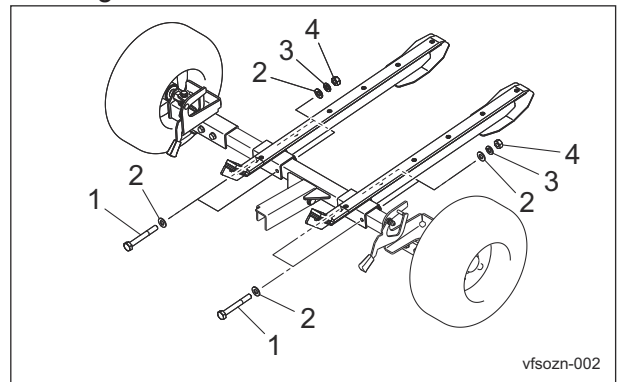

Connection between Axle Unit and Tilting Tables (Drum Loading Type)_002

1	Bolt
2	Washer
3	Spring washer
4	Nut

Handling Instructions

Connection between Axle Section and Tilting Tables (Tire Loading Type)

1. Remove the bolts securing the axle section and tire section.

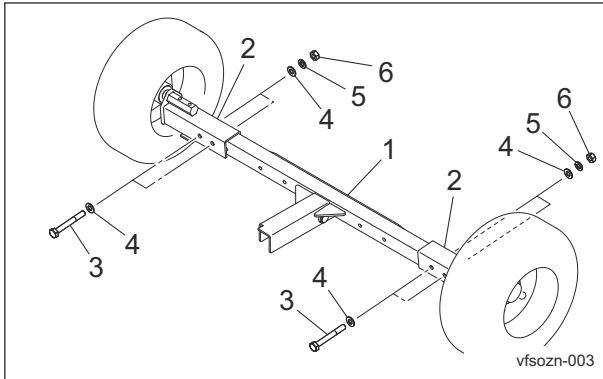

Connection between Axle Section and Tilting Tables (Tire Loading Type)_001

1	Axle section
2	Tire section
3	Bolt
4	Washer
5	Spring washer
6	Nut

2. Adjust the tread width.

Note:

The factory default position is that for a 22-inch mower.

3. Fit the tilting tables over the tire section.
4. Align the holes in the axle section, tire section and tilting tables.

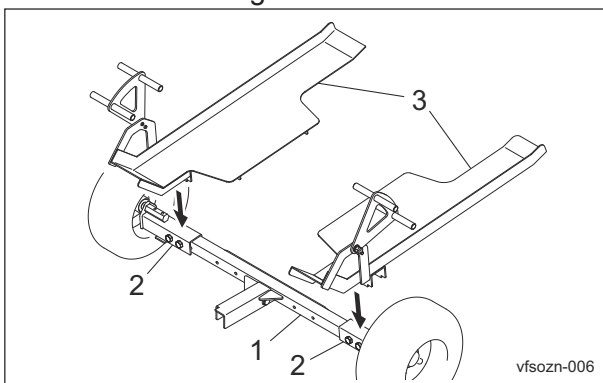

Connection between Axle Section and Tilting Tables (Tire Loading Type)_002

1	Axle section
2	Tire section
3	Tilting table

5. Install the bolts removed in step 1 to secure the tilting tables, axle section and tire section.

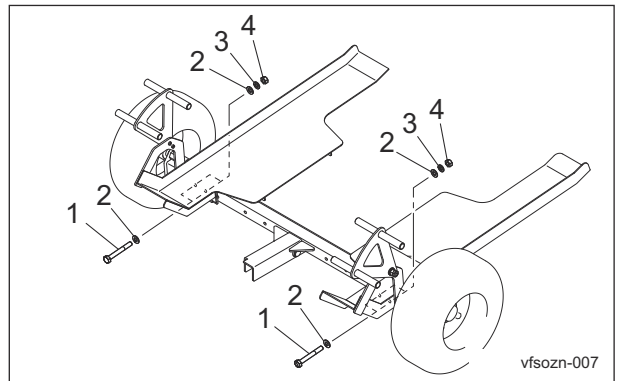

Connection between Axle Section and Tilting Tables (Tire Loading Type)_003

1	Bolt
2	Washer
3	Spring washer
4	Nut

Connection between Towing Section and Axle Section

1. Fit the towing section into the axle section.
2. Align the holes in the axle section and towing section.

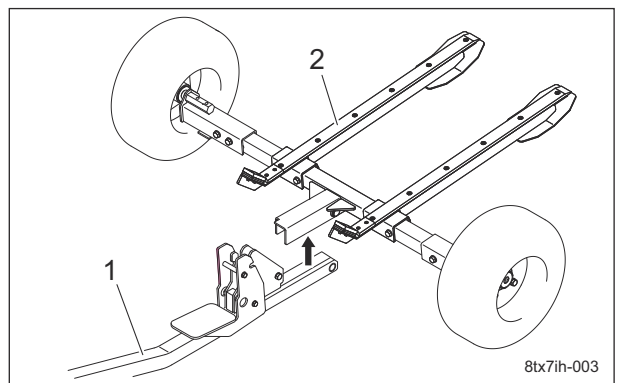

Connection between Towing Section and Axle Section_001

1	Towing section
2	Axle section

3. Apply grease to the pin, and then insert the pin through the holes of the axle section and towing section.
4. Install the washer.

Handling Instructions

5. Insert the cotter pin through the hole in the pin.

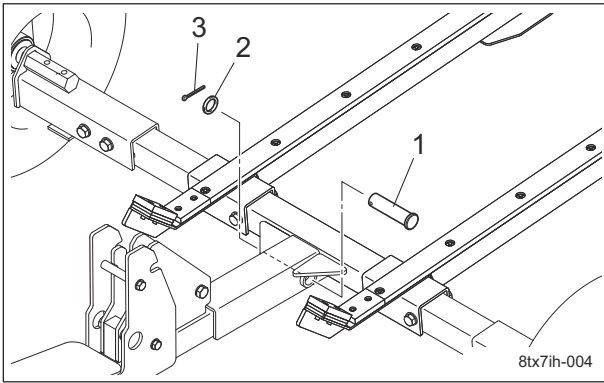

Connection between Towing Section and Axle Section_002

1	Pin
2	Washer
3	Cotter pin

2. Insert long fulcrum bolts B.

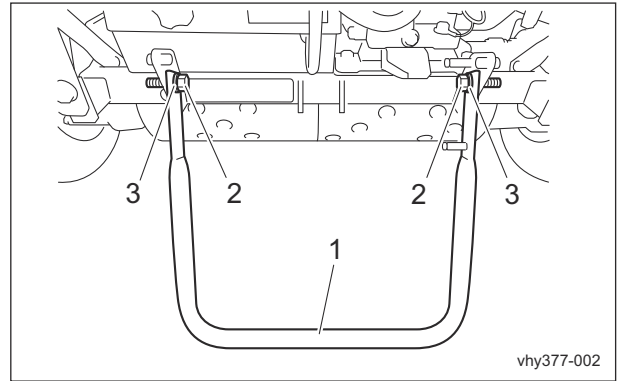

Installation of Greens Mower Fixture_002

1	Stand
2	Fulcrum bolt B
3	Washer

Installation of Greens Mower Fixture

For the included parts to be installed on the greens mower, refer to the parts catalog of this machine.

1. Remove fulcrum bolts A and the nuts for the stand of the greens mower to be loaded.

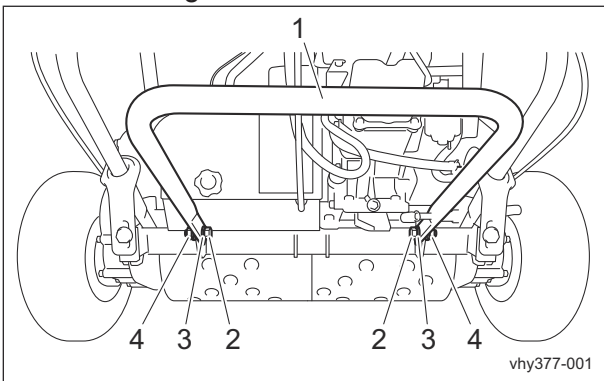

Installation of Greens Mower Fixture_001

1	Stand
2	Fulcrum bolt A
3	Washer
4	Nut

3. Temporarily install the side plate with the fulcrum bolt B and nut for the right side.

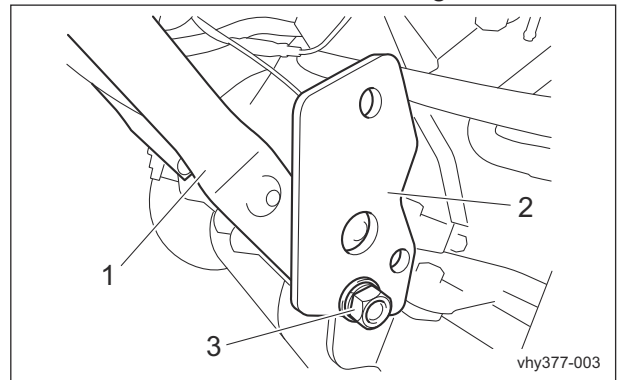

Installation of Greens Mower Fixture_003

1	Stand
2	Side plate
3	Nut

Handling Instructions

Important

The position for passing the clutch wire differs depending on the model of the greens mower. Be sure to pass the clutch wire at the correct position.

LM101

Pass the clutch wire below the fixture.

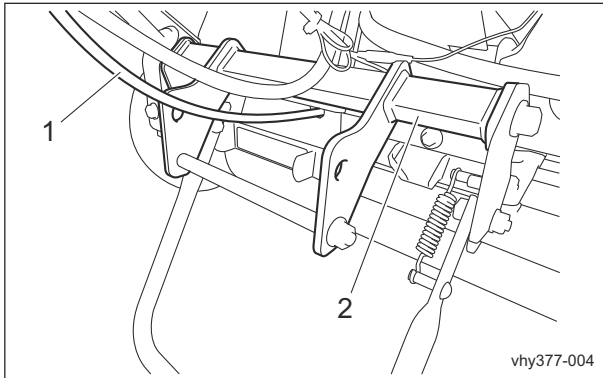

Installation of Greens Mower Fixture_004

1	Clutch wire
2	Fixture

LM18/56/66 series

Pass the clutch wire above the fixture.

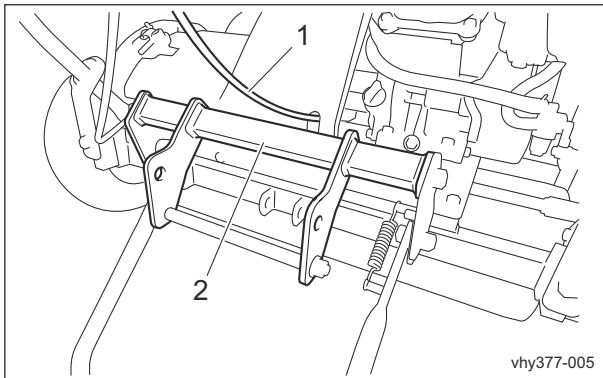

Installation of Greens Mower Fixture_005

1	Clutch wire
2	Fixture

4. Temporarily install the fixture with the fulcrum bolt B and nut for the left side.

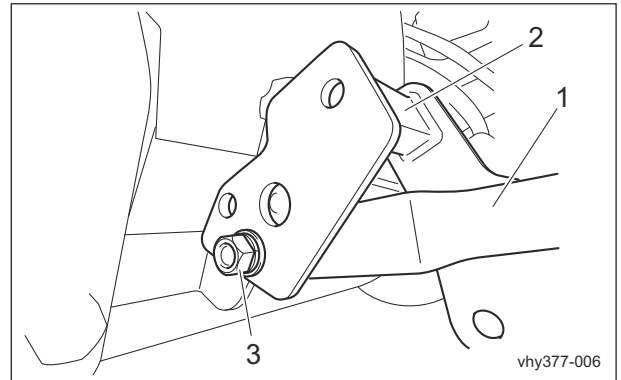

Installation of Greens Mower Fixture_006

1	Stand
2	Fixture
3	Nut

5. Secure the fixture to the side plate on the right side with the bolt.

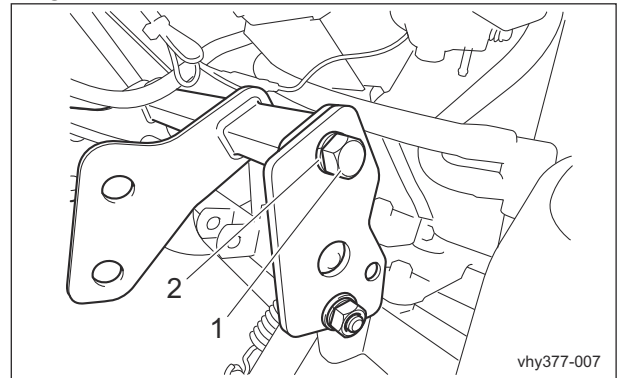

Installation of Greens Mower Fixture_007

1	Bolt
2	Spring washer

6. Align the holes in the stand mounting plate and in the fixture, and then secure them with the bolt and nut.

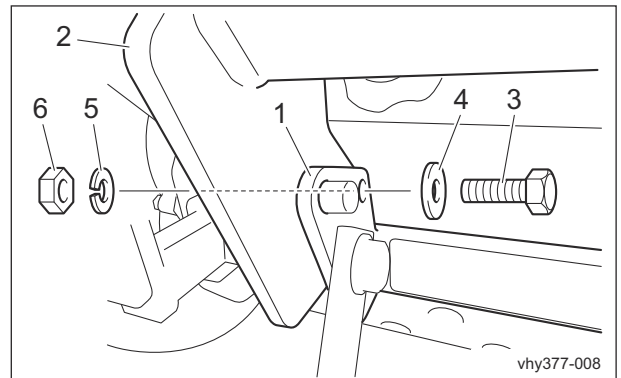

Installation of Greens Mower Fixture_008

Handling Instructions

Handling Instructions

1	Stand mounting plate
2	Fixture
3	Bolt
4	Washer
5	Spring washer
6	Nut

7. Tighten all bolts and nuts used to temporarily install the side plate and the fixture.

Important

The position for attaching the stand stay differs depending on the type of mower trailer that is used. Attach it at the correct position.

8. Install the stand stay with the nuts.

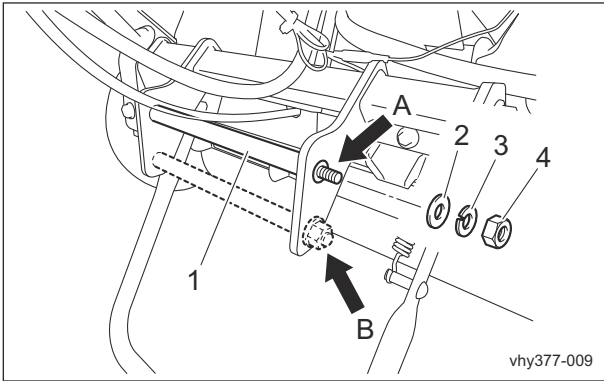

Installation of Greens Mower Fixture_009

1	Stand stay
2	Washer
3	Spring washer
4	Nut
A	Position of stand stay for mower drums loading
B	Position of stand stay for mower tires loading

Tire

Inspection of Tires

1. Make sure that there are no cracks, damage or abnormal wear.
2. Check the pneumatic pressure of the tires.

Tire size	Pneumatic pressure	
16 x 6.50-8	200 kPa (2.0 kgf/cm ²)	29 psi

Hitch

Inspection of Hitch

1. Make sure that there is no wear or deterioration of the hitch.
2. Make sure that there is no damage to the hitch.
3. Make sure that there is no deformation of the hitch.

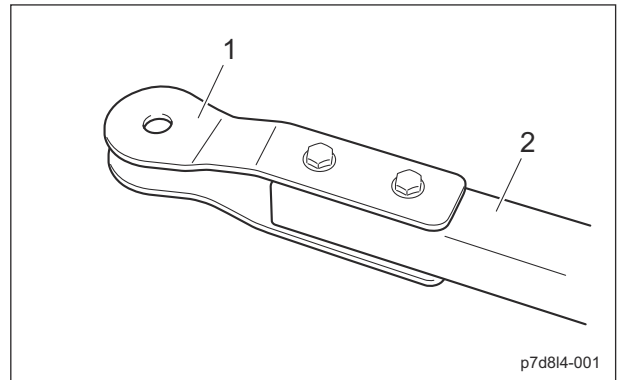

Inspection of Hitch_001

1	Hitch
2	Traction bar

Inspection before Use

The purpose of the machine inspection is to:

- Prevent accidents
- Prevent damage to the machine
- Maintain machine performance

Detecting machine malfunctions early helps prevent unexpected problems from occurring. If you detect any abnormalities with the machine, immediately perform maintenance or repairs.

Handling Instructions

Stay

Inspection of Stand Stay

1. Make sure that there is no wear or deterioration of the stand stay.
2. Make sure that there is no damage to the stand stay.
3. Make sure that there is no deformation of the stand stay.

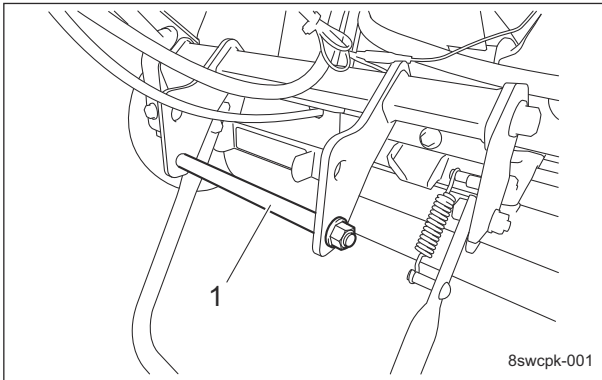

Inspection of Stand Stay_001

1	Stand stay
---	------------

Pedal Hook

Inspection of Pedal Hooks

1. Make sure that there is no wear or deterioration of the pedal hooks of the pedal and frame.
2. Make sure that there is no damage to the pedal hooks of the pedal and frame.
3. Make sure that there is no deformation of the pedal hooks of the pedal and frame.

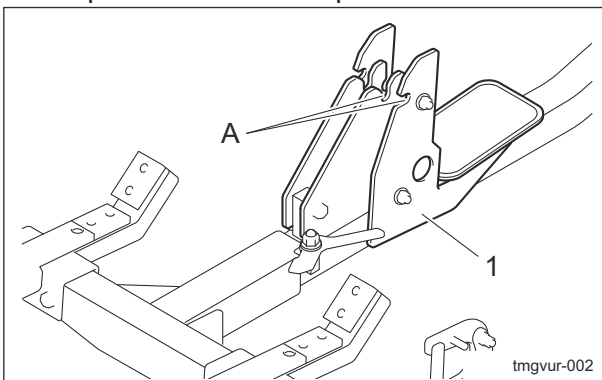

Inspection of Pedal Hooks_001

1	Pedal
A	Hook

Bolts and Nuts

Inspection of Bolts and Nuts

Important

The bolts and nuts may be loosened at the earlier stage of the use. Be sure to retighten or replace before operating the machine whenever there is any abnormality.

1. Check the bolts and nuts for looseness and coming off.
2. Check the bolts and nuts for cracks and damages.
3. Check the bolts and nuts for rust.
4. Check around the bolts and nuts for traces of rust fluid.
5. Check for unequal bolt length.
6. Check the bolts and nuts for stripped threads and abrasion.

Move

Traveling Procedure

1. Lift up the tilting tables.
2. Secure the axle with the axle lock lever.
3. Move the mower trailer by pulling the traction bar so that the tilting tables do not touch the ground.

Handling Instructions

Precautions for Connecting the Mower Trailer

⚠ Caution

Be sure to connect and disconnect the mower trailer on a level surface.

Important

The total weight of the trailer and greens mower is approximately 200 kg (440.92 lb). Have a vehicle ready with the ability to tow more than this weight.

Important

Have a vehicle ready onto which the included pin (φ20) can be installed. If anything other than the included pin is used, the hitch may be damaged.

Important

Make sure that the towing vehicle hitch connected with the mower trailer is sufficiently strong.

Procedure to Connect to The Mower Trailer

⚠ Warning

Be sure to install the clip pin so that the pin will not fall out during transportation.

Important

When connecting the mower trailer to the towing vehicle, adjust the trailer hitch so that the traction bar is parallel to the ground.

Important

The clip pin has a specific installation orientation. If the clip pin is installed with the wrong orientation, it may fall out.

The installation orientation of the clip pin is as follows.

■ Correct

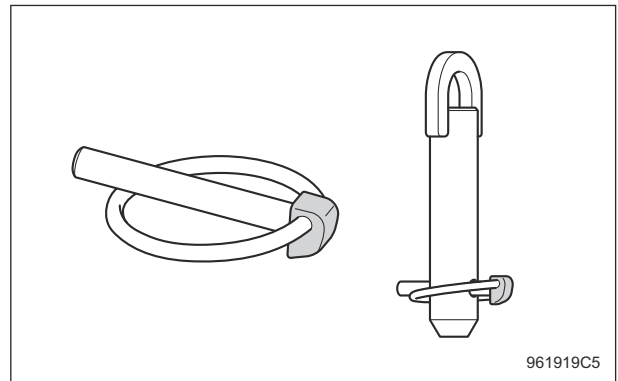

Procedure to Connect to The Mower Trailer_001

■ Incorrect

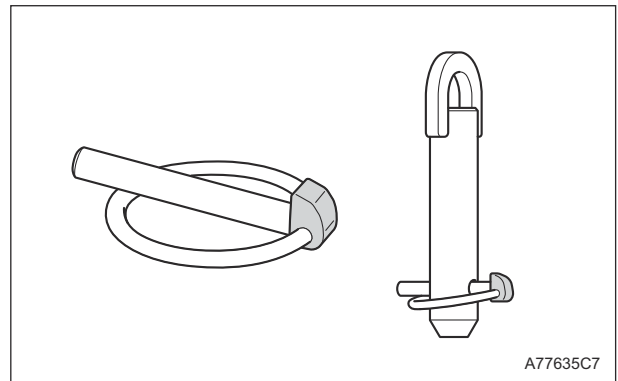

Procedure to Connect to The Mower Trailer_002

1. Align the mounting hole of the trailer mounting hitch with the connection of the towing vehicle.
2. Install the included pin into the hitch.
3. Check the orientation of the clip pin, and then install it so that it will not fall out.

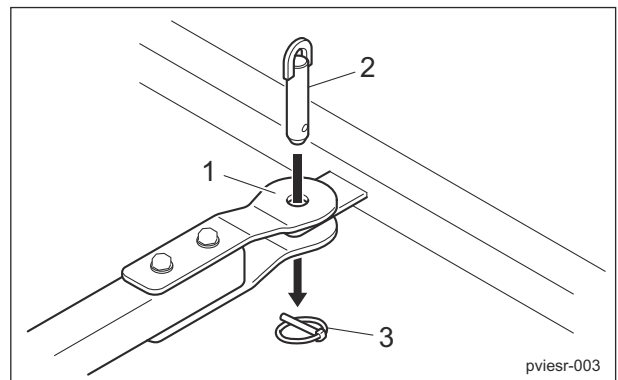

Procedure to Connect to The Mower Trailer_003

1	Connection
2	Pin
3	Clip pin

Handling Instructions

Loading and Unloading

Loading Procedure of Greens Mower

Caution

Before loading or unloading, chock the wheels of the mower trailer on a level surface in a safe location.

Caution

Be careful not to catch your foot on the mower trailer and fall.

Caution

Since the tilting tables may bounce up, make sure that there are no people around the machine.

1. Set the axle lock lever to the "Release" position, and then lower the tilting tables to the ground.
2. Place the greens mower facing backward towards the tilting tables.

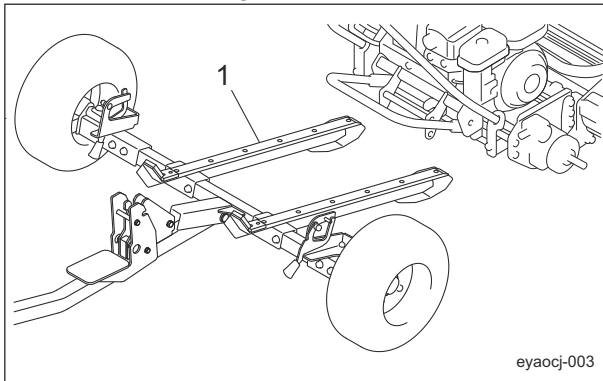

Loading Procedure of Greens Mower_001

1	Tilting table
---	---------------

3. Move the greens mower backward to load it onto the tilting tables of the mower trailer.

4. Insert the stand stay of the greens mower into the pedal hooks to secure it.

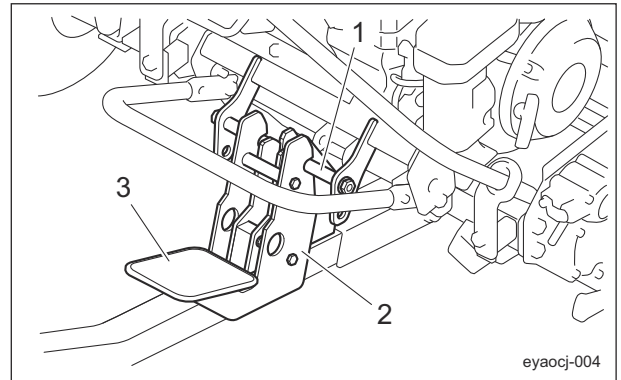

Loading Procedure of Greens Mower_002

1	Stand stay
2	Pedal hook
3	Pedal

5. Set the axle lock lever to the "Lock" position.
6. Set the drum shaft lock lever or mower tire lock lever to the "Lock" position.
7. Set the fuel cock of the greens mower to the "Close" position.

Unloading Procedure of Greens Mower

Caution

Before loading or unloading, chock the wheels of the mower trailer on a level surface in a safe location.

Caution

Be careful not to catch your foot on the mower trailer and fall.

Caution

Make sure that there are no people around the machine.

Caution

When unloading the greens mower, be extremely careful as it may suddenly pull on your hand.

1. Set the drum shaft lock lever or mower tire lock lever to the "Release" position.
2. Set the axle lock lever to the "Release" position.

Handling Instructions

3. Depress the pedal to release the stand stay of the greens mower from the pedal hooks.

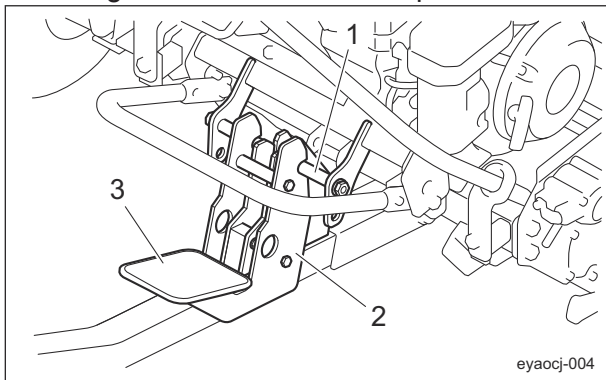

Unloading Procedure of Greens Mower_001

1	Stand stay
2	Pedal hook
3	Pedal

4. Bring the front roller into contact with the tilting tables, and then lower the tilting tables to the ground.
5. Move the greens mower forward to unload it from the mower trailer.

Towing

Precautions for Towing

Warning

When towing, travel at a speed no more than 20 km/h.
Travel slowly over bad roads and uneven surfaces.

Warning

Make turns at a low speed.
Making quick turns may cause the towing vehicle to roll over.

Caution

Since the towing vehicle and the mower trailer articulate at the hitch, a large turning radius difference occurs in curves.
Be mindful of the risk of collisions caused by a turning radius difference.

Caution

Before traveling in reverse, make sure that there are no people behind you.
Travel in reverse at low speed while carefully observing the movement of the trailer.

Caution

Be careful that the tow vehicle does not make contact with the trailer and overturn while going backward with turning on a slope.

Towing Procedure

1. Make sure that the pedal hooks are secured onto the stand stay of the greens mower.
2. Make sure that the drum shaft lock lever or mower tire lock lever is set to the "Lock" position so that the greens mower will not fall.
3. Make sure that the axle lock lever is set to the "Lock" position so that the tilting tables do not touch the ground.
4. Make sure that the towing vehicle and mower trailer are securely connected.
5. Start moving the towing vehicle slowly, and then maintain the traveling speed.

Transporting

Transporting Procedure

Before loading into a truck or trailer for transporting, disconnect from the towing vehicle.

When using a running board:

When loading into a truck or trailer for transporting, pull the traction bar. When unloading, push the traction bar.

When using a pallet:

When using a truck or trailer for transporting, place the mower trailer on the pallet before loading or unloading it.

Storage

Short-Term Storage

Short-term storage means that the machine is temporarily stored (within 1 month) without use.

Follow the instructions below for Short-term storage of the machine.

1. Cleaning

- Completely remove dirt, grass clippings, debris, oil stains, etc.

2. Storage

- Cover the machine and store it in a dry place where it will not be exposed to rain.
- Lower the tilting tables to the ground.
- Unload the greens mower from the mower trailer.
- Before disconnecting from the towing vehicle, use wheel stoppers to secure the trailer.

Handling Instructions

Precautions for Maintenance	Page 6-2
Lubrication	Page 6-2
About Lubrication	Page 6-2
Lubricating Points	Page 6-2
Adjustment	Page 6-4
Adjustment of Tread Width	Page 6-4
Adjustment of Trailer Hitch	Page 6-5
Adjustment of Drum Stopper	Page 6-7
Replacement	Page 6-8
Procedure to Remove/Install Tires	Page 6-8
Storage	Page 6-8
Long-Term Storage	Page 6-8

Maintenance

Precautions for Maintenance

Warning

The chapter "Maintenance" in this manual describes practical measures which should be performed by a mechanic with expertise. The owner should instruct the mechanic with expertise to perform maintenance service for this machine.

Caution

First, learn well the operations you plan to perform.

Important

Use tools appropriate for each operation.

Important

Use Baronsess genuine parts for replacement and accessories. Our product warranty may be void if you use non-genuine parts for replacement or accessories.

Lubrication

About Lubrication

It is necessary to lubricate moving parts so that they will not become stuck or damaged. The locations where lubricant is used are indicated in "Lubricating Points". Apply the lubricant.

Lubricating Points

Lubricating Points (Drum Loading Type)

Apply lubricant at the following locations as necessary.

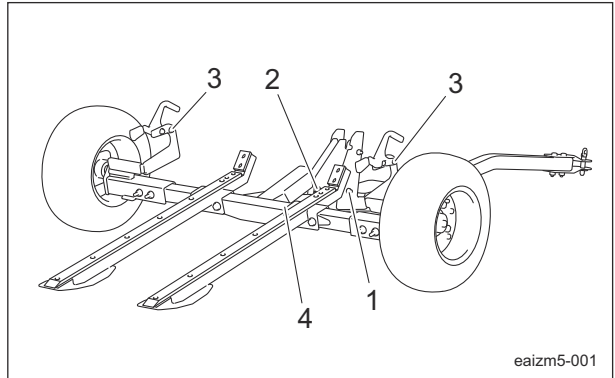

Lubricating Points (Drum Loading Type)_001

1	Pedal fulcrum	1
2	Axle lock lever	1
3	Drum shaft lock lever	2
4	Axle coupling pin	1

1. Pedal fulcrum

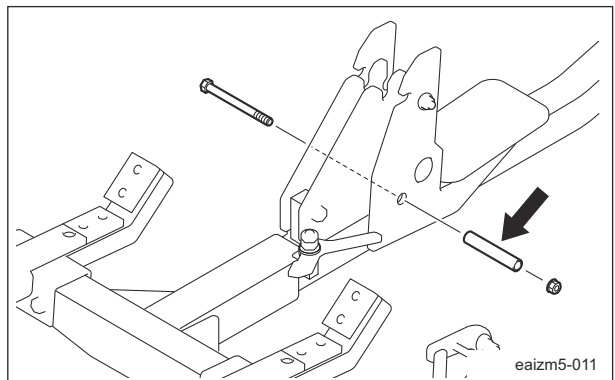

Lubricating Points (Drum Loading Type)_002

2. Axle lock lever

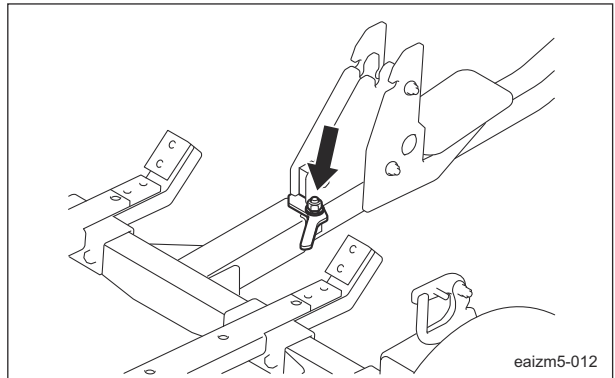

Lubricating Points (Drum Loading Type)_003

3. Drum shaft lock lever
There is one point each on the left and right.

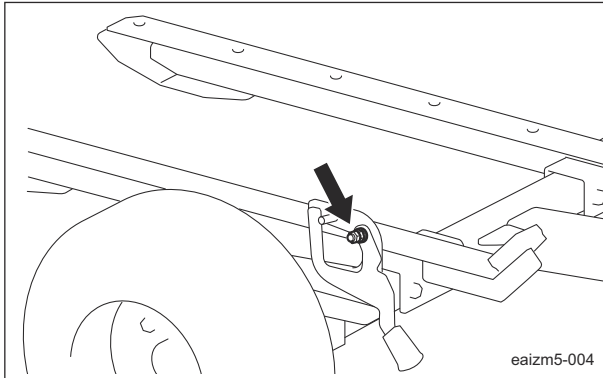

Lubricating Points (Drum Loading Type)_004

4. Axle coupling pin

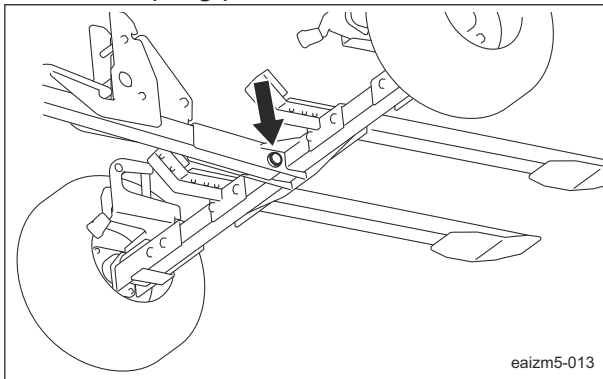

Lubricating Points (Drum Loading Type)_005

Lubricating Points (Tire Loading Type)

Apply lubricant at the following locations as necessary.

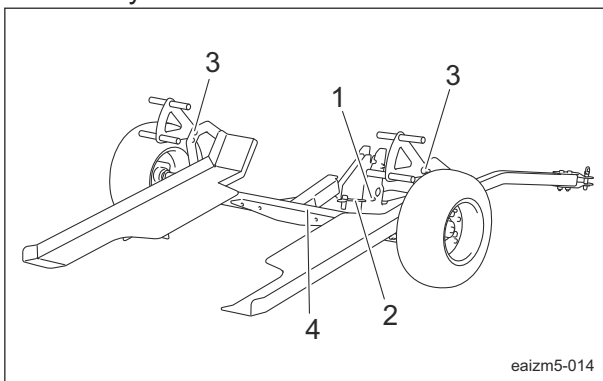

Lubricating Points (Tire Loading Type)_001

1	Pedal fulcrum	1
2	Axle lock lever	1
3	Mower tire lock lever	2
4	Axle coupling pin	1

1. Pedal fulcrum

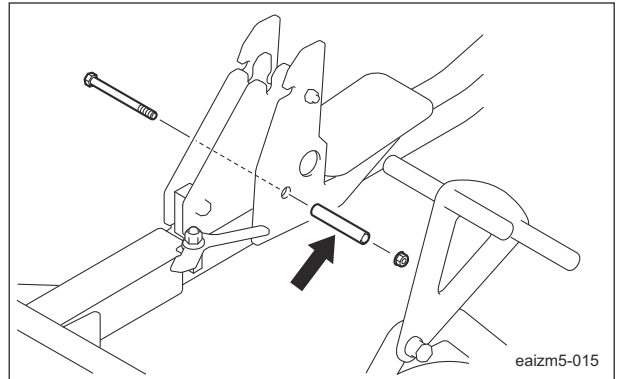

Lubricating Points (Tire Loading Type)_002

2. Axle lock lever

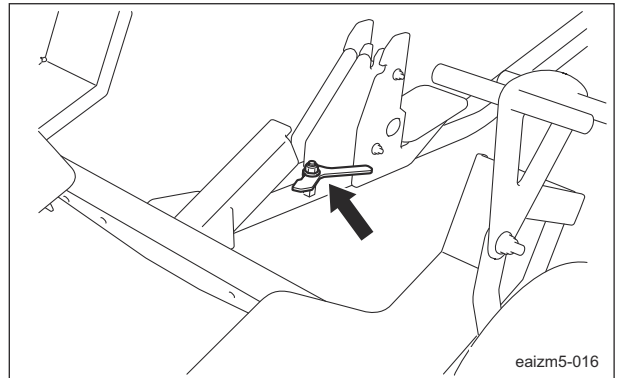

Lubricating Points (Tire Loading Type)_003

3. Mower tires lock lever
There is one point each on the left and right.

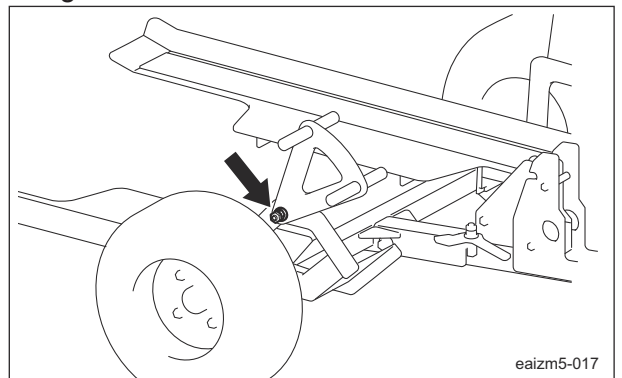

Lubricating Points (Tire Loading Type)_004

Maintenance

4. Axle coupling pin

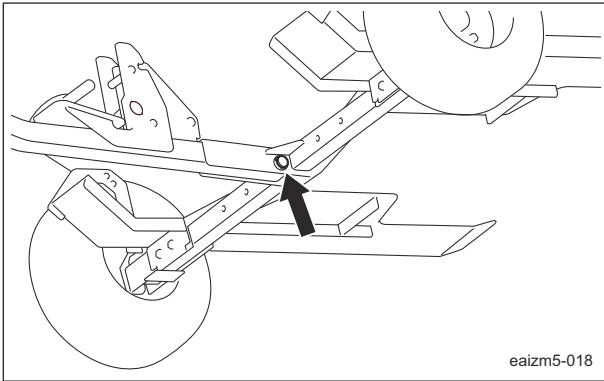

eaizm5-018

Lubricating Points (Tire Loading Type)_005

Adjustment

Adjustment of Tread Width

Adjustment of Tread Width (Drum Loading Type)

1. Remove the bolts securing the axle section and tire section.

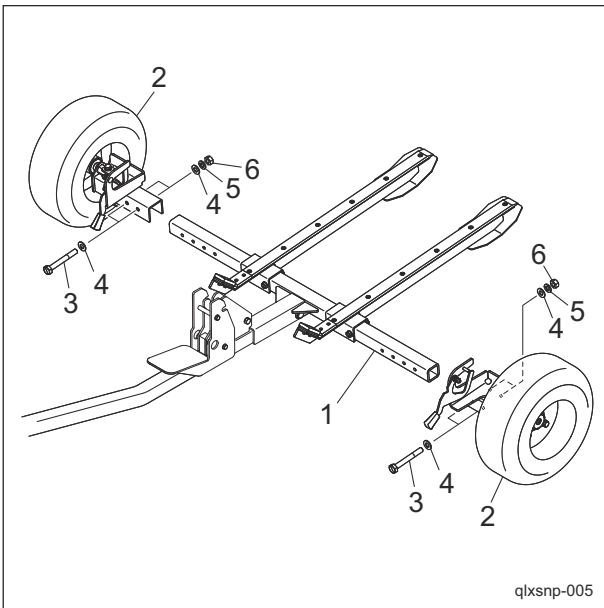

qlxsnp-005

Adjustment of Tread Width (Drum Loading Type)_001

1	Axle section
2	Tire section
3	Bolt
4	Washer
5	Spring washer
6	Nut

2. The installation position of the axle holes differs depending on the greens mower to be loaded.

Align the appropriate holes in the axle section and tire section.

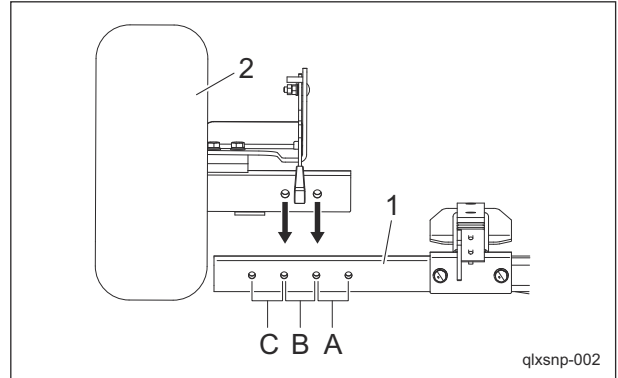

qlxsnp-002

Adjustment of Tread Width (Drum Loading Type)_002

1	Axle section
2	Tire section
A	18-inch mower
B	22-inch mower
C	26-inch mower

3. Install the bolt removed in step 1 to secure the axle section and tire section.

4. Follow the same steps to adjust the opposite side.

Note:

The factory default position is that for a 22-inch mower.

Adjustment of Tread Width (Tire Loading Type)

1. Remove the bolts securing the axle section, tire section and tilting tables.

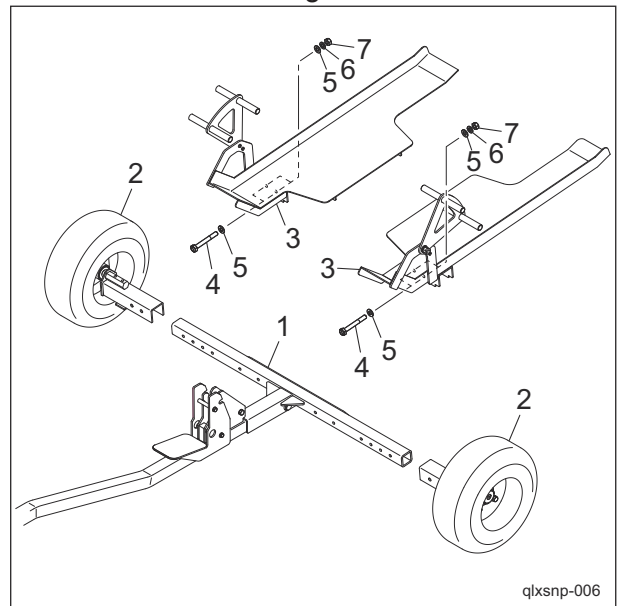

qlxsnp-006

Adjustment of Tread Width (Tire Loading Type)_001

1	Axle section
2	Tire section
3	Tilting table
4	Bolt
5	Washer
6	Spring washer
7	Nut

2. The installation position of the axle holes differs depending on the greens mower to be loaded.
Align the appropriate holes in the axle section, tire section and tilting table.

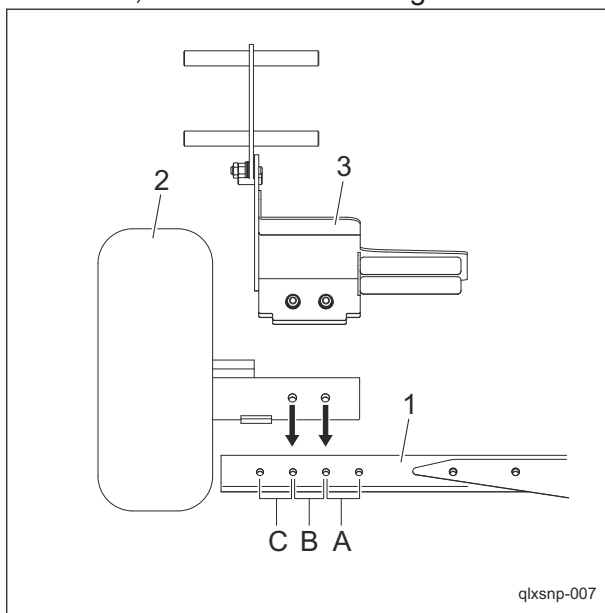

Adjustment of Tread Width (Tire Loading Type)_002

1	Axle section
2	Tire section
3	Tilting table
A	18-inch mower
B	22-inch mower
C	26-inch mower

3. Install the bolt removed in step 1 to secure the axle section, tire section and tilting table.
4. Follow the same steps to adjust the opposite side.

Adjustment of Trailer Hitch

When connecting the mower trailer to the towing vehicle, adjust the trailer hitch if the traction bar is not parallel to the ground.

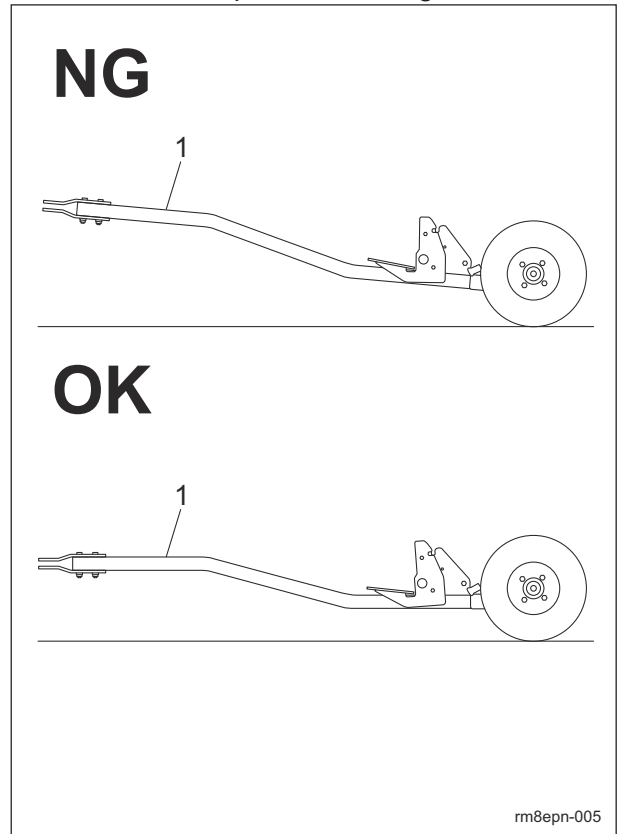

Adjustment of Trailer Hitch_001

1	Traction bar
---	--------------

The hitch can be adjusted to one of three heights.
Remove the bolt securing the hitch, and then install the hitch at the height that fits the towing vehicle.

Maintenance

• Standard hitch installation

The height from the ground to the trailer hitch is 299 mm (11.77 in).

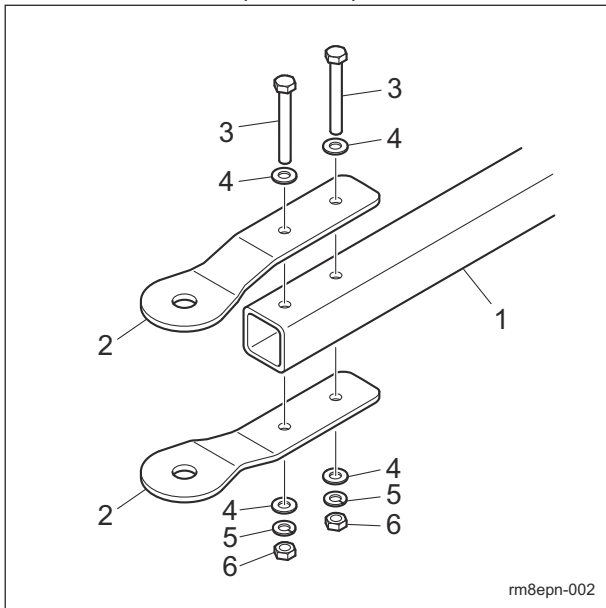

1	Traction bar
2	Hitch
3	Bolt
4	Washer
5	Spring washer
6	Nut

• Low hitch installation

The height from the ground to the trailer hitch is 270 mm (10.63 in).

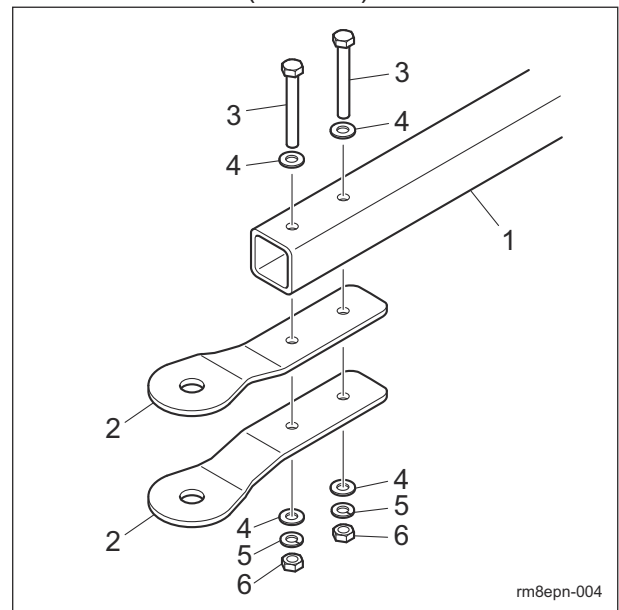

Adjustment of Trailer Hitch_002

1	Traction bar
2	Hitch
3	Bolt
4	Washer
5	Spring washer
6	Nut

Adjustment of Trailer Hitch_004

1	Traction bar
2	Hitch
3	Bolt
4	Washer
5	Spring washer
6	Nut

• High hitch installation

The height from the ground to the trailer hitch is 329 mm (12.95 in).

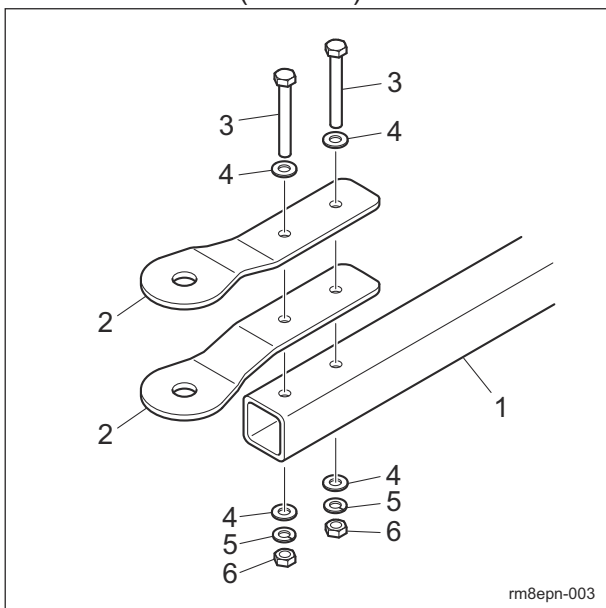

Adjustment of Trailer Hitch_003

Note:

The factory default position is the standard hitch installation.

Adjustment of Drum Stopper

The drum stopper is the function for drum loading type.

When a greens mower is loaded onto the mower trailer, adjust the gap between the drum and drum stopper if it is 4.5 mm (0.177 in) or more.

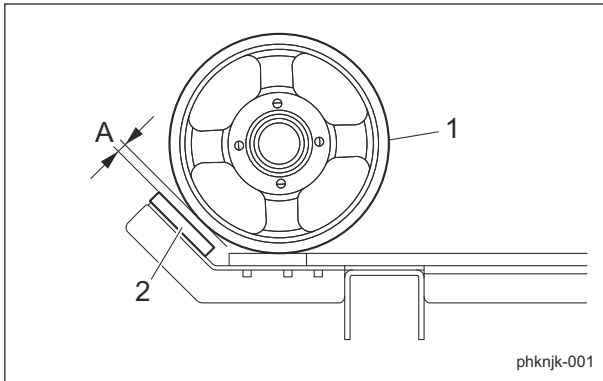

Adjustment of Drum Stopper_001

1	Drum
2	Drum stopper
A	Gap

1. Remove the screw securing the drum stopper, and then add the spacer.

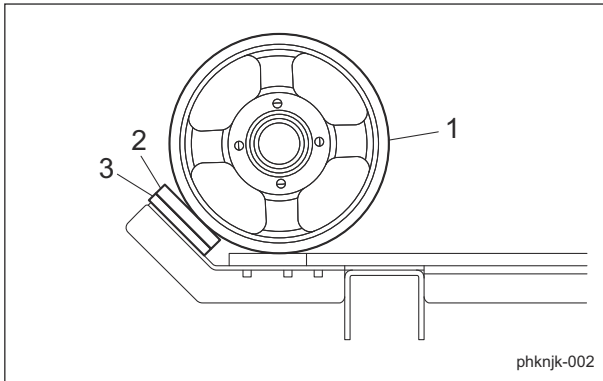

Adjustment of Drum Stopper_002

1	Drum
2	Drum stopper
3	Spacer

2. Make sure that the stand stay can be secured by the hooks.

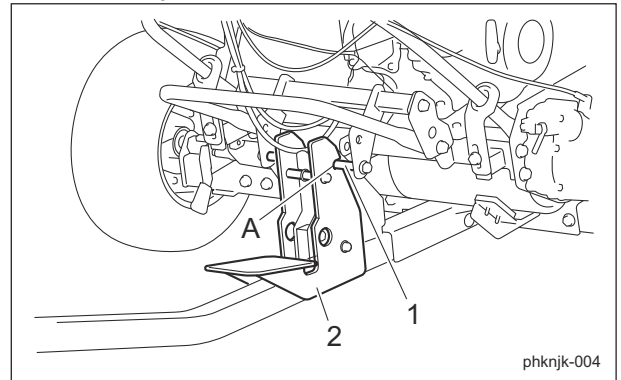

Adjustment of Drum Stopper_003

1	Stand stay
2	Pedal
A	Hook

Maintenance

Replacement

Procedure to Remove/Install Tires

Follow the steps below to remove the tires.

1. Remove the bolts.

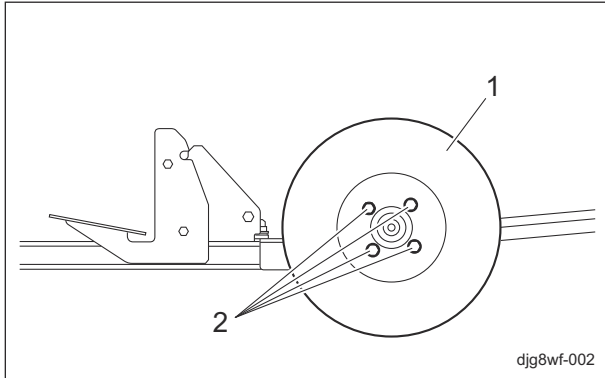

Procedure to Remove/Install Tires_001

1	Tire
2	Bolt

2. While lifting the tire up, pull it toward you to remove it from the wheel mounting seat.

3. Follow the same steps to remove the tire on the opposite side.

⚠ Caution

Refer to the Tightening Torque table. Note that the Baroness product warranty may not apply to defects caused by incorrect or overtorque tightening, etc.

Important

Tighten the bolts in the tightening order (diagonally).

For installing the tires, reverse the removing procedure.

Storage

Long-Term Storage

Follow the instructions below for long-term storage of the machine.

1. Cleaning

- Completely remove dirt, grass clippings, debris, oil stains, etc.

2. Greasing and lubricating

- Supply oil and apply grease to appropriate parts.

3. Tire pneumatic pressure

- Set the tire air pressure slightly higher than normal, and then place the machine on a board to avoid humidity.

4. Storage

- Cover the machine and store it in a dry place where it will not be exposed to rain.
- Lower the tilting tables to the ground.
- Unload the greens mower from the mower trailer.
- Before disconnecting from the towing vehicle, use wheel stoppers to secure the trailer.

Precautions for Repair Page 7-2

Adjustment Page 7-2

Adjustment of Axle Lock Lever Page 7-2

Adjustment of Drum Shaft Lock
Lever Page 7-2

Adjustment of Mower Tire Lock
Lever Page 7-3

Repair

Precautions for Repair

Warning

The chapter "Repair" in this manual describes practical measures which should be performed by a mechanic with expertise. The owner should instruct the mechanic with expertise to perform repair service for this machine.

Caution

First, learn well the operations you plan to perform.

Important

Use tools appropriate for each operation.

Important

Use Baronsess genuine parts for replacement and accessories. Our product warranty may be void if you use non-genuine parts for replacement or accessories.

Adjustment

Adjustment of Axle Lock Lever

Adjust the axle lock lever so that it moves when pushed with a finger. The operating force of the axle lock lever is 15 – 30 N-m (153 – 306 kgf-cm). Adjust by tightening the nut.

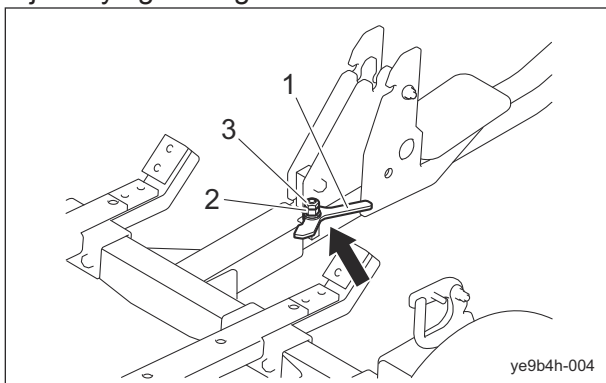

Adjustment of Axle Lock Lever_001

1	Axle lock lever
2	Nut
3	Lock nut

Adjustment of Drum Shaft Lock Lever

The drum shaft lock lever is the function for drum loading type. Adjust the drum shaft lock lever so that it will not move by its own weight when lifted 90° from the "Lock" position, then released. The operating force of the drum shaft lock lever is 30 – 50 N-m (306 – 510 kgf-cm). Adjust by tightening the nut.

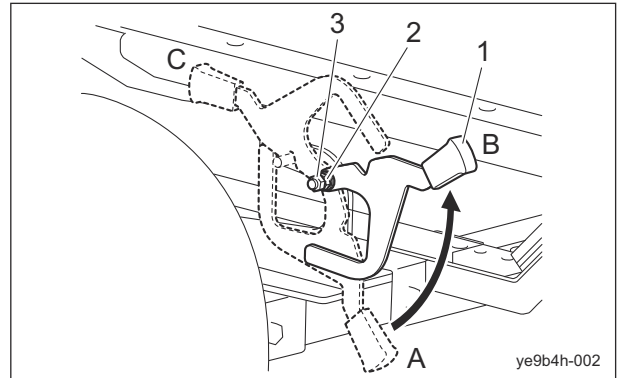

Adjustment of Drum Shaft Lock Lever_001

1	Drum shaft lock lever
2	Nut
3	Lock nut
A	Lock
B	90-degree position
C	Release

Adjustment of Mower Tire Lock Lever

The mower tire lock lever is the function for tire loading type.

Adjust the mower tire lock lever so that it will not move by its own weight when moved 30° from the "Lock" position, then released.

The operating force of the mower tire lock lever is 40 – 60 N-m (408 – 612 kgf-cm).

Adjust by tightening the nut.

Mower tire lock lever (TR50---0511ZD)

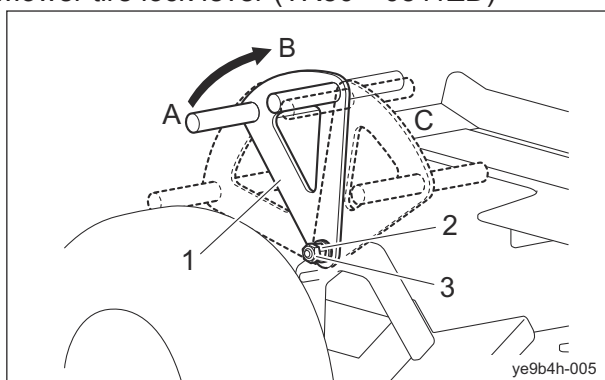

Adjustment of Mower Tire Lock Lever_001

Mower tire lock lever (TR50---0514ZD)

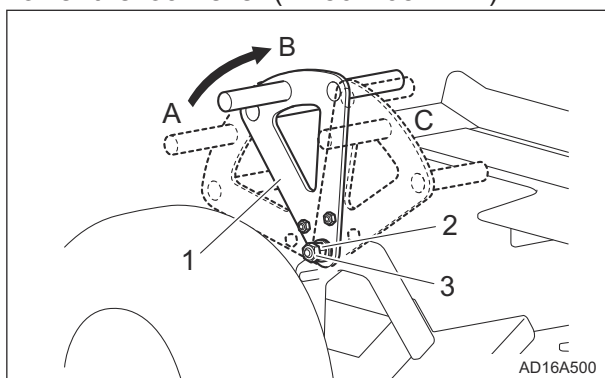

Adjustment of Mower Tire Lock Lever_002

1	Mower tire lock lever
2	Nut
3	Lock nut
A	Lock
B	30-degree position
C	Release

Appended Table

- Tightening TorquesPage 8-2**
 - Standard Tightening TorquesPage 8-2
 - Principal Tightening Torques Page 8-4
- Daily Check List Page 8-4**
- Maintenance Schedule Page 8-5**
- List of Adjusted Value Page 8-5**

Appended Table

Appended Table

Tightening Torques

Important

Refer to the Tightening Torque table.
Note that the Baroness product warranty may not apply to defects caused by incorrect or overtorque tightening, etc.

Standard Tightening Torques

Bolts and Nuts



Important

A number of bolts are used in each part of this machine.
Be sure to re-tighten the bolts and nuts, because they may be loosened at the earlier stage of the use.

- As to the bolts and nuts without any special instruction, tighten them in appropriate tightening torque with proper tool.
Too much tightening may cause the looseness or damage of the screw.
- The strength of tightening is determined by types of screws, strength, the friction of thread face or base face and others.
The table below is for the galvanized or parkerized bolts.
In case that the strength of internal thread is weak, it is not applied.
- Do not use rusty or sand attached "screw."
Otherwise, it may cause insufficient tightening even if you apply the specified tightening torque.
The friction of the screw face becomes higher and the tightening torque is canceled out by the friction, therefore sufficient tightening cannot be applied.
- If "screw" is wet by water or oil, do not tighten it with normal tightening torque.
If the screw is wet, the torque coefficient will get smaller and it may result in too much tightening.
Too much tightening may cause looseness by the screw stretched or result in damage.
- Do not use a bolt experienced too much burden.
- Using the impact wrench requires the skill.
Do exercise as much as possible for steady tightening.

Appended Table

Nominal diameter	General bolt		
	Strength classification 4.8		
	 tib3yb-001		
	N-m	kgf-cm	lb-in
M5	3 - 5	30.59 - 50.99	26.55 - 44.26
M6	7 - 9	71.38 - 91.77	61.96 - 79.66
M8	14 - 19	142.76 - 193.74	123.91 - 168.17
M10	29 - 38	295.71 - 387.49	256.68 - 336.34
M12	52 - 67	530.24 - 683.20	460.25 - 593.02
M14	70 - 94	713.79 - 958.52	619.57 - 831.99
M16	88 - 112	897.34 - 1142.06	778.89 - 991.31
M18	116 - 144	1,182.85 - 1,468.37	1,026.72 - 1,274.54
M20	147 - 183	1,498.96 - 1,866.05	1,301.10 - 1,619.73
M22	295	3,008.12	2,611.05
M24	370	3,772.89	3,274.87
M27	550	5,608.35	4,868.05
M30	740	7,545.78	6,549.74

Nominal diameter	Heat-treated bolt					
	Strength classification 8.8			Strength classification 10.9		
	 tib3yb-002			 tib3yb-003		
	N-m	kgf-cm	lb-in	N-m	kgf-cm	lb-in
M5	5 - 7	50.99 - 71.38	44.26 - 61.96	7 - 10	71.38 - 101.97	61.96 - 88.51
M6	8 - 11	81.58 - 112.17	70.81 - 97.36	14 - 18	142.76 - 183.55	123.91 - 159.32
M8	23 - 29	234.53 - 295.71	203.57 - 256.68	28 - 38	285.52 - 387.49	247.83 - 336.34
M10	45 - 57	458.87 - 581.23	398.30 - 504.51	58 - 76	591.43 - 774.97	513.36 - 672.68
M12	67 - 85	683.20 - 866.75	593.02 - 752.34	104 - 134	1,060.49 - 1,366.40	920.50 - 1186.03
M14	106 - 134	1,080.88 - 1,366.40	938.21 - 1,186.03	140 - 188	1,427.58 - 1,917.04	1,239.14 - 1,663.99
M16	152 - 188	1,549.94 - 1,917.04	1,345.35 - 1,663.99	210 - 260	2,141.37 - 2,651.22	1,858.71 - 2,301.26
M18	200 - 240	2,039.40 - 2,447.28	1,770.20 - 2,124.24	280 - 340	2,855.16 - 3,466.98	2,478.28 - 3,009.34
M20	245 - 295	2,498.27 - 3,008.12	2,168.50 - 2,611.05	370 - 450	3,772.89 - 4,588.65	3,274.87 - 3,982.95
M22	-	-	-	530	5,404.41	4,691.03
M24	-	-	-	670	6,831.99	5,930.17
M27	-	-	-	1,000	10,197.00	8,851.00
M30	-	-	-	1,340	13,663.98	11,860.34

Note:
The same values are applied to "fine screw thread."

Appended Table

Principal Tightening Torques

Tightening Torque by Model

TR50

Tighten the following bolts and nuts at the torque specified in the table.

For thread locking adhesive, apply a middle strength thread locker (ThreeBond 1322 or equivalent anaerobic sealant).

Location	Code	Part name	Tightening torque			Thread locking adhesive
			N-m	kgf-cm	lb-in	
Axle	K0013100802	BOLT, HT M10-80	58 - 76	591.43 - 774.97	513.36 - 672.68	-
Tilting Table	K0013100802	BOLT, HT M10-80	58 - 76	591.43 - 774.97	513.36 - 672.68	-
Axle and tilting table	K0013100902	BOLT, HT M10-90	58 - 76	591.43 - 774.97	513.36 - 672.68	-

Daily Check List

TR50

- . . . Inspect, adjust, supply, clean (first time)
- . . . Inspect, adjust, supply, clean
- ▲ . . . Replace (first time)
- △ . . . Replace

Maintenance Item	Before Work	After Work	Remarks
Check tire	○		
Check hitch	○		
Check stand stay	○		
Check pedal hooks	○		
Check bolts and nuts	○		
Check machine exterior	○		
Clean machine exterior		○	

Maintenance Schedule

TR50

- . . . Inspect, adjust, supply, clean (first time)
- . . . Inspect, adjust, supply, clean
- ▲ . . . Replace (first time)
- △ . . . Replace

Maintenance Item	Before Work	After Work	When Required	Remarks
Lubricate			○	
Adjust tread width			○	
Adjust trailer hitch			○	
Adjust drum stopper			○	Drum loading type
Adjust axle lock lever			○	
Adjust drum shaft lock lever			○	Drum loading type
Adjust mower tire lock lever			○	Tire loading type

- The values for consumables are not guaranteed.

List of Adjusted Value

Gap between drum and drum stopper	4.5 mm (0.177 in) or more
Operating force of axle lock lever	15 - 30 N-m (153 - 306 kgf-cm)
Operating force of drum shaft lock lever	30 - 50 N-m (306 - 510 kgf-cm)
Operating force of mower tire lock lever	40 - 60 N-m (408 - 612 kgf-cm)

Appended Table

Daily Check Records Page 9-2

Maintenance RecordsPage 9-3



Records

Records

Daily Check Records

TR50

Use this table freely for your records of the daily check.

Model		Serial Number	
-------	--	---------------	--

Items										
Check tire										
Check hitch										
Check stand stay										
Check pedal hooks										
Check bolts and nuts										
Check machine exterior										
Clean machine exterior										

Maintenance Records

TR50
 Use this table freely for your records of the maintenance.

Model										Serial Number	
Items											
Lubricate											
Adjust tread width											
Adjust trailer hitch											
Adjust drum stopper											
Adjust axle lock lever											
Adjust drum shaft lock lever											
Adjust mower tire lock lever											

Records

Records

BARONESS[®]
Quality on Demand

 **KYOEISHA CO., LTD.**
Head Office 1-26, Miyuki-cho, Toyokawa-city, Tel :+81-533-84-1390
Aichi-pref, 442-8530 JAPAN Fax:+81-533-84-1220