

VM60 · VM62 · VM66

Verti Cutter

Owner's Operating Manual

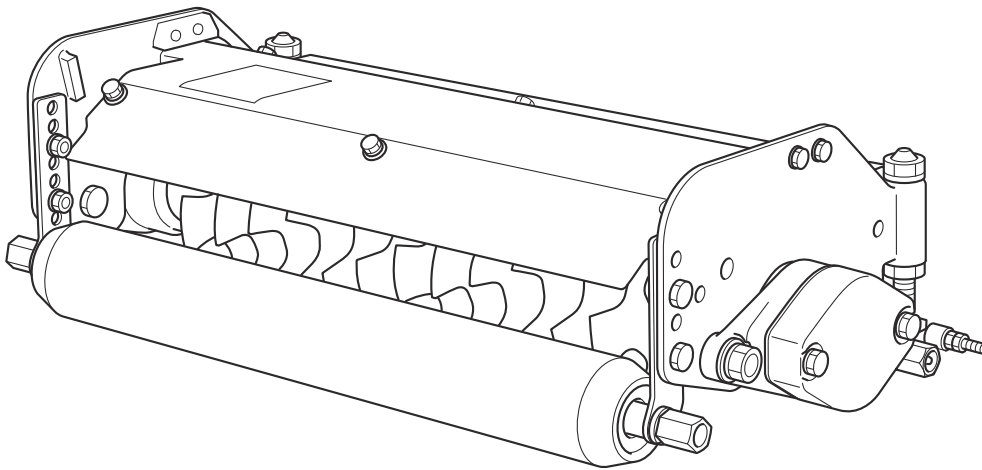

Serial No. VM60: 10001- · VM62: 10001- · VM66: 10001-

"Required reading"
Read this manual before using the machine.

BARONESS[®]
Quality on Demand

Ver.1.2

Greeting

Thank you for purchasing the Baroness product. This manual describes the proper handling, adjustment, and inspection of your product. We hope you will use the product safely, and take advantage of its best performance. For details on the handling, adjustment and inspection of the main vehicle, refer to the Owner's Operating Manual for the main vehicle.

QR Code

(*QR Code is a registered trademark of DENSO WAVE INCORPORATED.)

A QR code for this verti cutter is printed on the serial number plate.

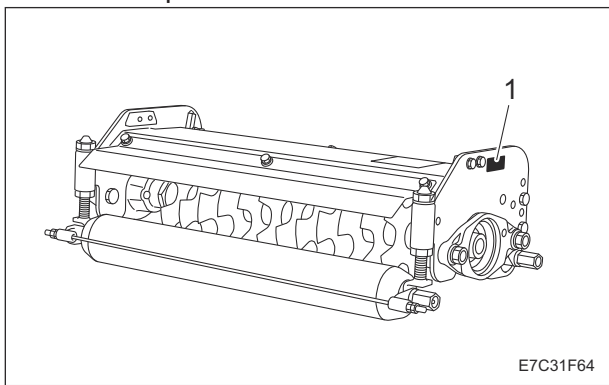

QR Code_001

1	QR code
---	---------

Scan the QR code with your smartphone for easy access to Baroness Manual Reference Service where you can browse Owner's Operating Manual and Parts Catalog.
 VM60: <https://doc.baroness-international.com/manuals/VM60>



QR Code_002

VM62: <https://doc.baroness-international.com/manuals/VM62>



QR Code_003

VM66: <https://doc.baroness-international.com/manuals/VM66>



QR Code_004

Read this manual carefully to ensure that you thoroughly understand how to properly operate and maintain the product, and to avoid causing injury to yourself or others.

The operator is responsible for operating the product properly and safely.

Maintenance service for this machine should be performed by a mechanic with expertise.

If you have any questions concerning maintenance or genuine parts, please contact a Baroness dealer or Kyoisha.





When making inquiries about your product, please specify the model and serial number.

When loaning or transferring the product, please also provide this manual together with the product.

Kyoisha Co., Ltd.

Warning Symbols

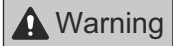
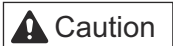
This manual uses the following warning symbols for handling precautions that are important for your safety.

 <p>696cq5-001</p>	<p>Warning symbol</p>
<p>This symbol indicates the articles regarding “Danger,” “Warning,” or “Caution.” Those articles describe important safety precautions and so read them carefully to understand completely before operating the machine. Failure to adequately follow these safety precautions may cause an accident.</p>	
<p> Danger</p> <p>This symbol indicates that serious injury or death will occur if the warning is ignored.</p> <p> Warning</p> <p>This symbol indicates that serious injury or death may occur if the warning is ignored.</p> <p> Caution</p> <p>This symbol indicates that injury or damage to property may occur if the warning is ignored.</p> <p> Important</p> <p>This symbol indicates precautions on the mechanism of the machine.</p>	

Introduction

Precautionary Statement

 Caution

The information described in this manual is subject to change for improvement without prior notice.

When replacing parts, be sure to use genuine Baroness parts or parts designated by Kyoisha.

Note that the Baroness product warranty may not apply to defects caused by the use of parts from other companies.

Prior to use, carefully read the following manuals to thoroughly understand the contents for safe and correct operation.

- Baroness Owner's Operating Manual

Purpose

This verti cutter is intended for vertical cutting at golf courses.

Do not use this machine in any way other than its intended purpose, and do not modify the machine.

Operating this verti cutter for other purposes and modifying it may be very dangerous and may cause damage to the machine.

Safety	Page 1-1
Safe Operating Practices	Page 1-2
Disposal	Page 2-1
Recycle and Waste Disposal	Page 2-2
Product Overview	Page 3-1
Specifications	Page 3-2
Names of Each Section	Page 3-4
Regulation Decals	Page 3-4
Safety Signs and Instruction Signs	Page 3-5
Handling Instructions	Page 4-1
Handling Precautions	Page 4-2
Installation	Page 4-2
Inspection before Use	Page 4-21
Operations	Page 4-22
Cleaning after Use	Page 4-23
Storage	Page 4-24
Maintenance	Page 5-1
Precautions for Maintenance	Page 5-2
Greasing	Page 5-2
Adjustment and Replacement	Page 5-4
Storage	Page 5-8
Appended Table	Page 6-1
Tightening Torques	Page 6-2
Daily Check List	Page 6-4
Maintenance Schedule	Page 6-4
List of Adjusted Values	Page 6-4
Records	Page 7-1
Daily Check Records	Page 7-2
Maintenance Records	Page 7-3

Contents

Safe Operating Practices Page 1-2

Safety

Failure to adequately follow these safety precautions may cause an accident resulting in injury or death.

⚠ Danger

This product is designed to ensure safe operation and has been tested and inspected thoroughly before shipment from the factory. The product is equipped with safety devices to prevent accidents.

However, whether the product demonstrates its original performance level depends on the manner in which it is operated and handled, as well as the manner in which it is managed on a daily basis.

Inappropriate use or management of the product may result in injury or death.

Observe the following safety instructions to ensure safe operation.

Safe Operating Practices

Read Safe Operating Practices described in the Owner's Operating Manual of Baroness main vehicle equipped with this verti cutter thoroughly.

Recycle and Waste Disposal Page 2-2

About RecyclePage 2-2

About Waste Disposal Page 2-2

Disposal

Recycle and Waste Disposal

About Recycle

Recycling battery etc. is recommended for environmental conservation and economical use of resources.

It may be required by local laws.

About Waste Disposal

Make sure that waste generated when servicing or repairing the machine is disposed of in accordance with local regulations. (e.g. waste oil, antifreeze, rubber products, and wires etc.)

Specifications Page 3-2

- Specifications List Page 3-2
- Features of Verti Cutter Page 3-3

Names of Each Section Page 3-4

Regulation Decals Page 3-4

- Positions of Regulation Decals Page 3-4
- Description of Regulation Decals Page 3-4

Safety Signs and Instruction Signs Page 3-5

- About Safety Decals and Instruction
Decals Page 3-5
- Positions of Safety Decals and
Instruction Decals Page 3-5
- Description of Safety Decals and
Instruction Decals Page 3-5

Product Overview

Specifications

Specifications List

VM60

Model		VM60	
Name		Verti Cutter30	
Dimensions	Total length	364 mm	14.33 in
	Total width	955 mm	37.60 in
	Total height	220 mm	8.66 in
Weight		44.0 kg	97.00 lb
Operating width		575 mm	22.64 in
Operating depth		0 - 6.0 mm	0 - 0.24 in
Vertical Blade	Number per unit	16	
	Diameter	165 mm	6.5 in
	Thickness	1.2 mm	0.047 in
	Space between blades	37 mm	1.46 in

VM62

Model		VM62	
Name		Verti Cutter22	
Dimensions	Total length	364 mm	14.33 in
	Total width	745 mm	29.33 in
	Total height	220 mm	8.66 in
Weight		36.0 kg	79.37 lb
Operating width		422 mm	16.61 in
Operating depth		0 - 6.0 mm	0 - 0.24 in
Vertical Blade	Number per unit	12	
	Diameter	165 mm	6.5 in
	Thickness	1.2 mm	0.047 in
	Space between blades	37 mm	1.46 in

Product Overview

VM66

Model		VM66	
Name		Verti Cutter26	
Dimensions	Total length	364 mm	14.33 in
	Total width	847 mm	33.35 in
	Total height	220 mm	8.66 in
Weight		40.0 kg	88.18 lb
Operating width		498 mm	19.61 in
Operating depth		0 - 6.0 mm	0 - 0.24 in
Vertical Blade	Number per unit	14	
	Diameter	165 mm	6.5 in
	Thickness	1.2 mm	0.047 in
	Space between blades	37 mm	1.46 in

Features of Verti Cutter

1. The verti cutter can be installed in the 3-Unit Reel Mower and 5-Unit Reel Mower.
2. You can operate this machine with a cutting depth up to the maximum 6 mm (0.24 in).
3. The scraper is installed in the rear roller.

Product Overview

Names of Each Section

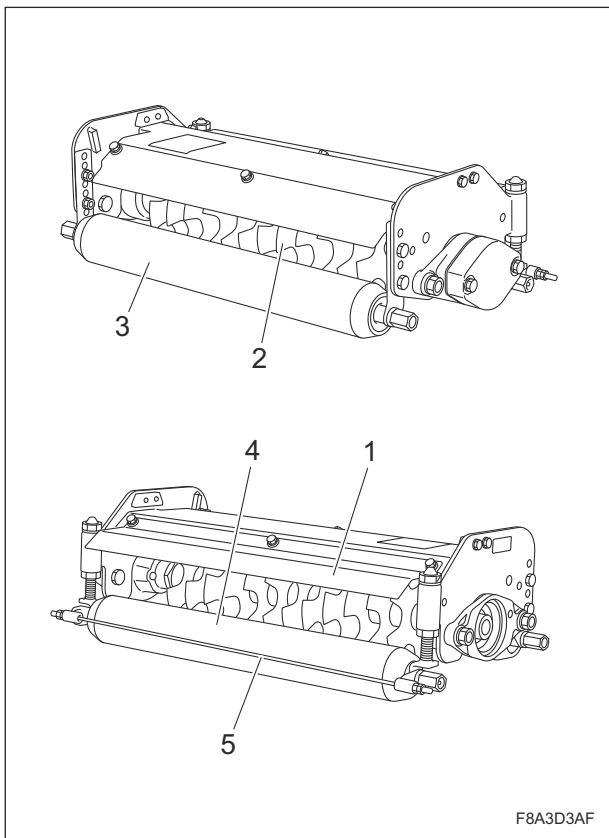

Names of Each Section_001

1	Dumping cover
2	Vertical blade
3	Front roller
4	Rear roller
5	Rear scraper

Regulation Decals

Positions of Regulation Decals

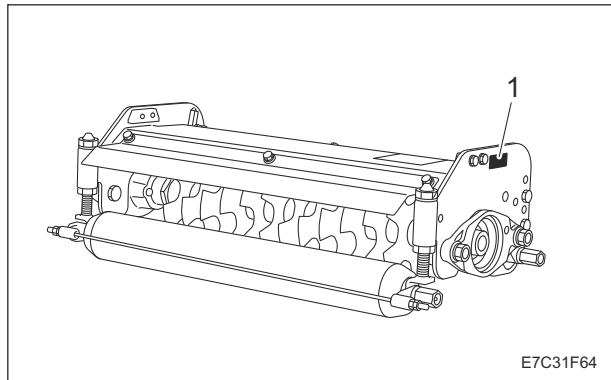

Positions of Regulation Decals_001

1	Serial number plate
---	---------------------

Description of Regulation Decals

Serial Number Plate

The serial number plate indicates the model and serial number of the machine. A QR code is also printed for browsing Owner's Operating Manual and Parts Catalog. (*QR Code is a registered trademark of DENSO WAVE INCORPORATED.)

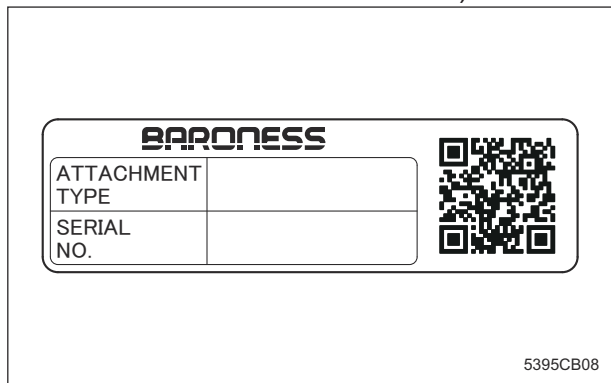

Serial Number Plate_001

Safety Signs and Instruction Signs

About Safety Decals and Instruction Decals

Important

Safety decals and instruction decals are attached to this verti cutter. Make sure that decals are preserved in their entirety. If they are damaged, become dirty, or peel off, replace them with new ones.

Part numbers for decals that need to be replaced are listed in the parts catalog. Order them from a Baroness dealer or Kyoeshia.

Positions of Safety Decals and Instruction Decals

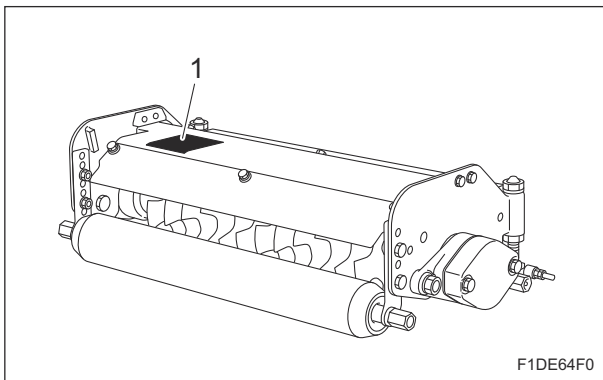

Positions of Safety Decals and Instruction Decals_001

- | | |
|---|-----------------------------|
| 1 | Caution to mutilation decal |
|---|-----------------------------|

Description of Safety Decals and Instruction Decals

Caution to Mutilation Decal

K4205001600
DECAL, CAUTION TO MUTILATION

Warning

May cut your hand or leg - Stop the cutter rotation and engine. Otherwise you may get injured.

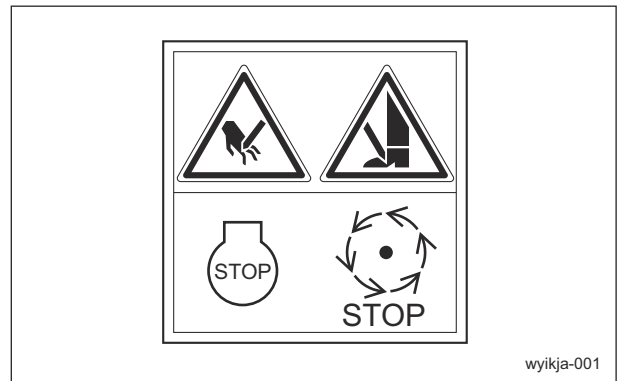

Caution to Mutilation Decal_001

Product Overview

Handling Instructions

Handling Precautions	Page 4-2
Installation	Page 4-2
Precautions about Installation	Page 4-2
LM331	Page 4-2
LM351	Page 4-8
LM551 • LM551A • LM551B	Page 4-11
LM2700 • LM2710	Page 4-15
LM3200 • LM3200C • LM3210 • LM3210A	Page 4-18
Inspection before Use	Page 4-21
Verti Cutter	Page 4-21
Operations	Page 4-22
Vertical Cutting Procedure	Page 4-22
Cleaning after Use	Page 4-23
Verti Cutter	Page 4-23
Storage	Page 4-24
Short-Term Storage	Page 4-24

Handling Instructions

Handling Precautions

Important

This manual contains descriptions for handling the verti cutter.
 For details on handling the main vehicle, refer to this manual and the Owner's Operating Manual for the main vehicle.

Installation

Precautions about Installation

Warning

Before installing or removing the verti cutter, apply the parking brake of the main vehicle and stop the engine.

Caution

Install and remove the verti cutter on a flat, stable place.

Caution

Install and remove the verti cutter by two or more people since it is very heavy.

Caution

Vertical blades are edged tools. Handle them carefully, since they could cut your hands or legs.

LM331

Installation of Verti Cutter #1 (LH6/LS6 Installed Type)

Important

Apply sufficient grease to the mower connecting shaft when installing the mower arm to the mower connecting shaft.

1. Install the verti cutter.

[1] Install the inner copper washer, iron washer, and copper washer onto the mower connecting shaft in this order.

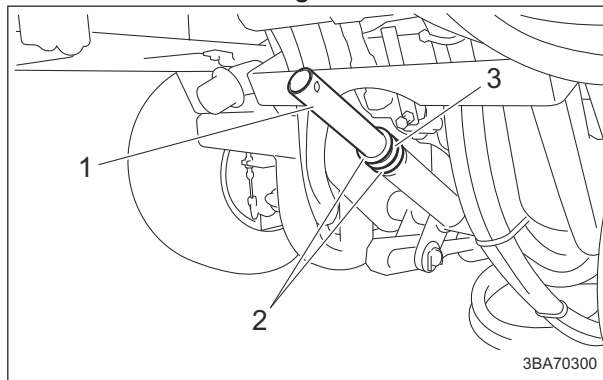

Installation of Verti Cutter #1 (LH6/LS6 Installed Type)_001

1	Mower connecting shaft
2	Copper washer
3	Iron washer

[2] Insert the mower arm into the mower connecting shaft.

[3] Install the outer copper washer, iron washer, and copper washer onto the mower connecting shaft in this order.

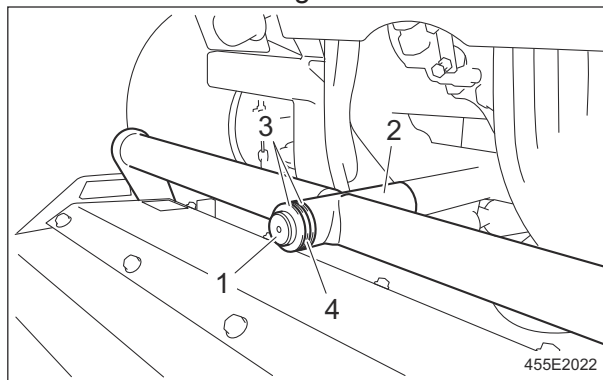

Installation of Verti Cutter #1 (LH6/LS6 Installed Type)_002

1	Mower connecting shaft
2	Mower arm
3	Copper washer
4	Iron washer

[4] Install the collar.

[5] Install the round-head pin.

Handling Instructions

[6] Install the snap pin.

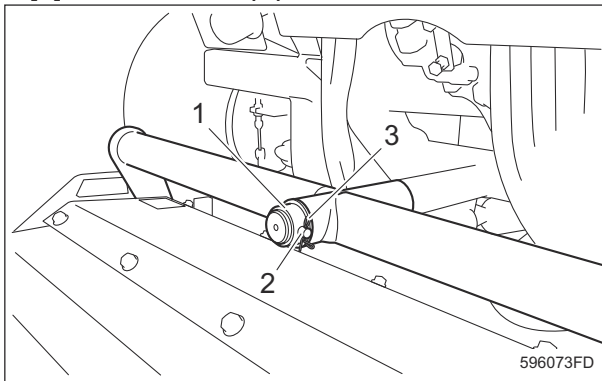

Installation of Verti Cutter #1 (LH6/LS6 Installed Type)_003

1	Collar
2	Round-head pin
3	Snap pin

Important

When installing the gear motor, apply sufficient grease to the motor shaft and the motor shaft mounting section on the vertical shaft side.

2. Install the gear motor.

- [1] Install the packing and the gear motor.
- [2] Tighten the bolts to secure the gear motor.

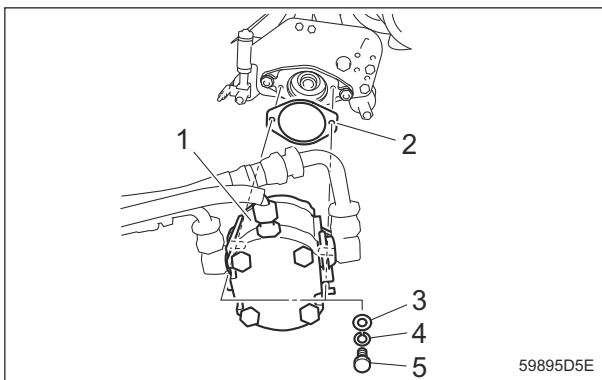

Installation of Verti Cutter #1 (LH6/LS6 Installed Type)_004

1	Gear motor
2	Packing
3	Washer
4	Spring washer
5	Bolt

3. Make sure that the mower arm contacts the mower stopper.

- [1] Start the engine.
- [2] Raise the verti cutter.

[3] Stop the engine.

- [4] Make sure that the mower arm contacts the mower stopper.
If the mower arm does not contact the mower stopper, adjust the mower stopper.
(Refer to "Adjustment of Mower Stopper" in the Owner's Operating Manual for the main vehicle.)

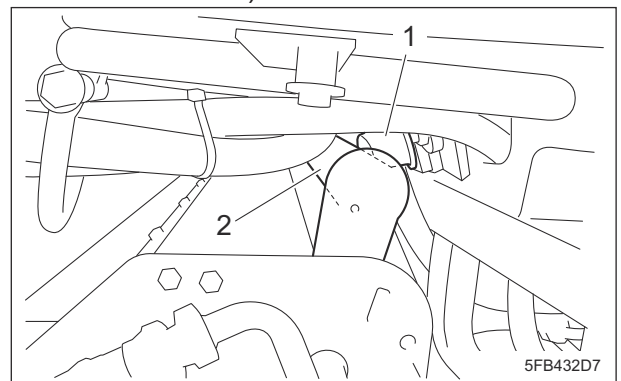

Installation of Verti Cutter #1 (LH6/LS6 Installed Type)_005

1	Mower stopper
2	Mower arm

Removal of Verti Cutter #1 (LH6/LS6 Installed Type)

- 1. Remove the gear motor.
 - [1] Remove the bolt, spring washer and washer.
 - [2] Remove the gear motor and packing.

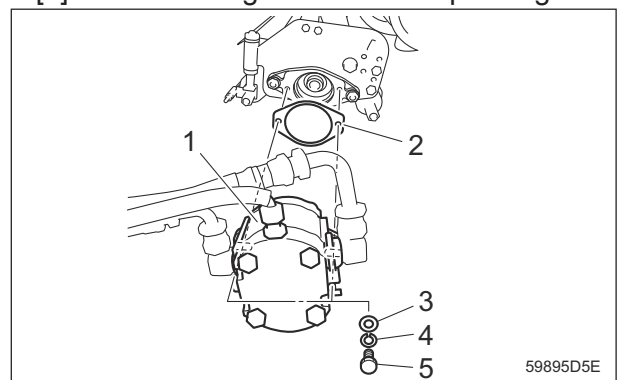

Removal of Verti Cutter #1 (LH6/LS6 Installed Type)_001

1	Gear motor
2	Packing
3	Washer
4	Spring washer
5	Bolt

- 2. Remove the verti cutter.
 - [1] Remove the snap pin.
 - [2] Remove the round-head pin.

Handling Instructions

[3] Remove the collar.

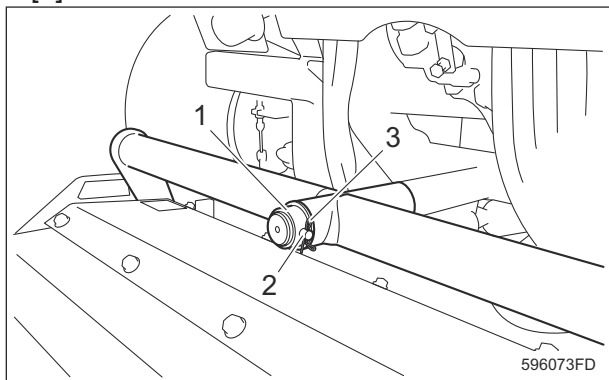

Removal of Verti Cutter #1 (LH6/LS6 Installed Type)_002

1	Collar
2	Round-head pin
3	Snap pin

[4] Remove the outer copper washers and iron washer from the mower connecting shaft.

[5] Pull out the mower arm from the mower connecting shaft to remove the verti cutter.

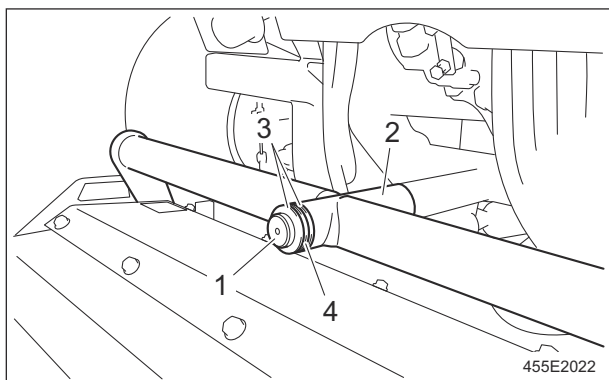

Removal of Verti Cutter #1 (LH6/LS6 Installed Type)_003

1	Mower connecting shaft
2	Mower arm
3	Copper washer
4	Iron washer

[6] Remove the inner copper washers and iron washer from the mower connecting shaft.

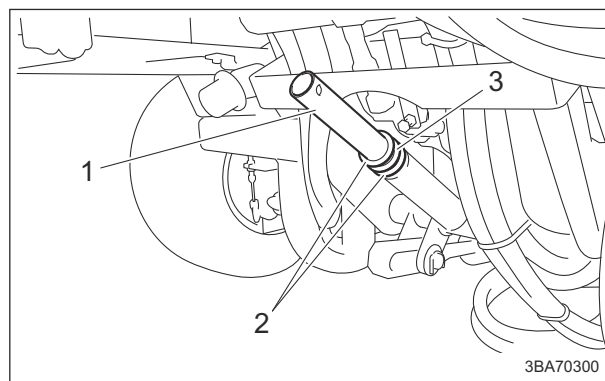

Removal of Verti Cutter #1 (LH6/LS6 Installed Type)_004

1	Mower connecting shaft
2	Copper washer
3	Iron washer

Installation of Verti Cutter #2·#3 (LH6 Installed Type)

1. Remove the mower connecting fitting.

[1] Remove the cotter pin.

[2] Remove the flat-head pin.

[3] Remove the mower connecting fitting from the mower connecting shaft.

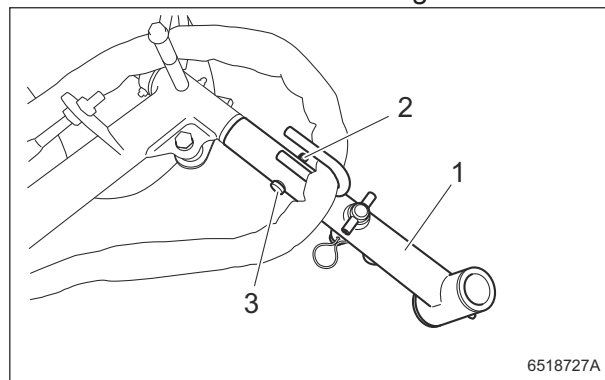

Installation of Verti Cutter #2·#3 (LH6 Installed Type)_001

1	Mower connecting fitting
2	Cotter pin
3	Flat-head pin

Handling Instructions

Important

Apply sufficient grease to the mower connecting shaft when installing the mower arm to the mower connecting shaft.

2. Install the verti cutter.

- [1] Align the direction of holes of the mower arm and the mower connecting shaft, and insert the mower arm into the mower connecting shaft.

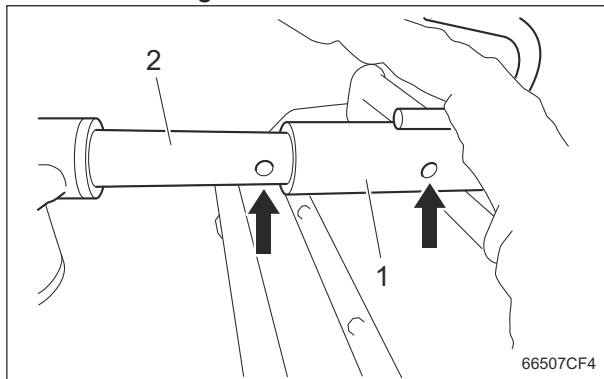

Installation of Verti Cutter #2·#3 (LH6 Installed Type)_002

1	Mower arm
2	Mower connecting shaft

- [2] Install the flat-head pin.
- [3] Install the cotter pin.

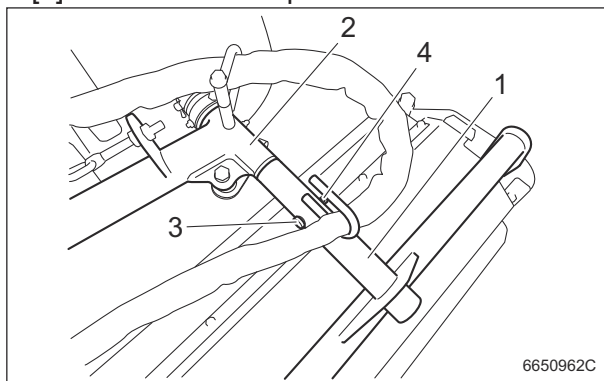

Installation of Verti Cutter #2·#3 (LH6 Installed Type)_003

1	Mower arm
2	Mower connecting shaft
3	Flat-head pin
4	Cotter pin

Important

When installing the gear motor, apply sufficient grease to the motor shaft and the motor shaft mounting section on the vertical shaft side.

3. Install the gear motor.

- [1] Install the packing and the gear motor.
- [2] Tighten the bolts to secure the gear motor.

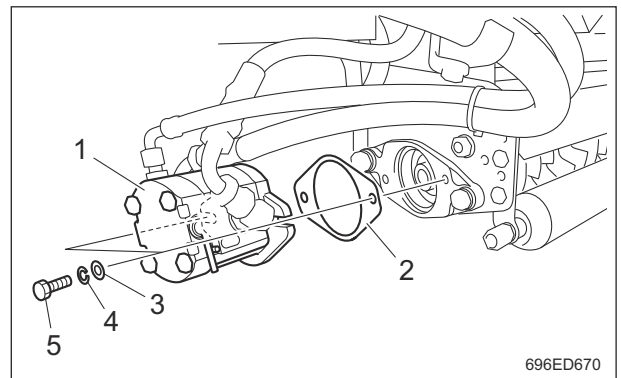

Installation of Verti Cutter #2·#3 (LH6 Installed Type)_004

1	Gear motor
2	Packing
3	Washer
4	Spring washer
5	Bolt

4. Make sure that the mower arm contacts the mower stopper.

- [1] Start the engine.
- [2] Raise the verti cutter.
- [3] Stop the engine.
- [4] Make sure that the mower arm contacts the mower stopper.

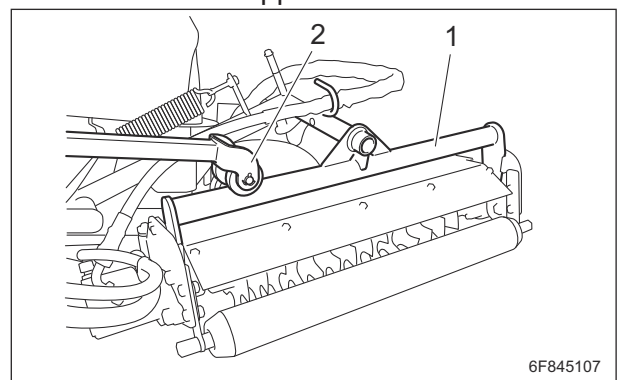

Installation of Verti Cutter #2·#3 (LH6 Installed Type)_005

Handling Instructions

1	Mower arm
2	Mower stopper

Removal of Verti Cutter #2·#3 (LH6 Installed Type)

1. Remove the gear motor.
 - [1] Remove the bolt, spring washer and washer.
 - [2] Remove the gear motor and packing.

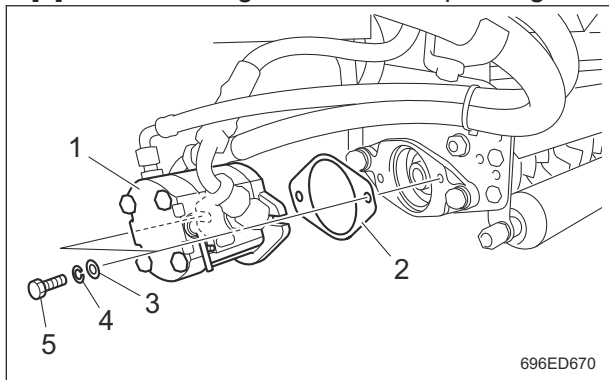

Removal of Verti Cutter #2·#3 (LH6 Installed Type)_001

1	Gear motor
2	Packing
3	Washer
4	Spring washer
5	Bolt

2. Remove the verti cutter.
 - [1] Remove the cotter pin.
 - [2] Remove the flat-head pin.
 - [3] Pull out the mower arm from the mower connecting shaft to remove the verti cutter.

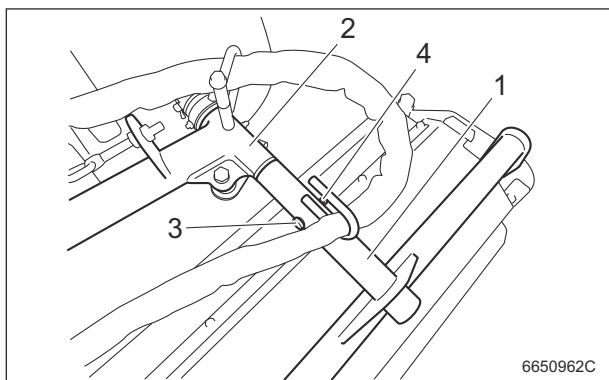

Removal of Verti Cutter #2·#3 (LH6 Installed Type)_002

1	Mower arm
2	Mower connecting shaft
3	Flat-head pin
4	Cotter pin

Installation of Verti Cutter #2·#3 (LS6 Installed Type)

Important

Apply sufficient grease to the mower arm when installing the mower arm to the mower connecting fitting .

1. Install the verti cutter.
 - [1] Insert the mower arm into the mower connecting fitting.

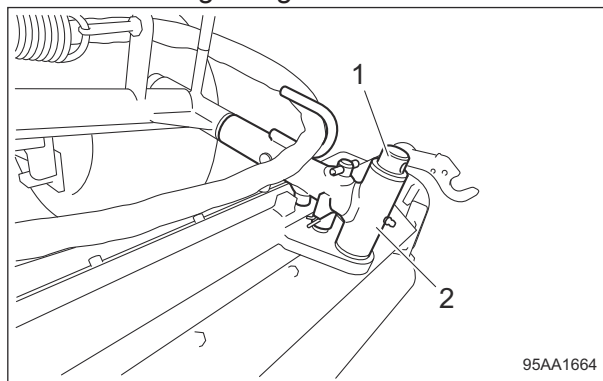

Installation of Verti Cutter #2·#3 (LS6 Installed Type)_001

1	Mower arm
2	Mower connecting fitting

- [2] Install the collar.
- [3] Install the flat-head pin.
- [4] Install the snap pin.

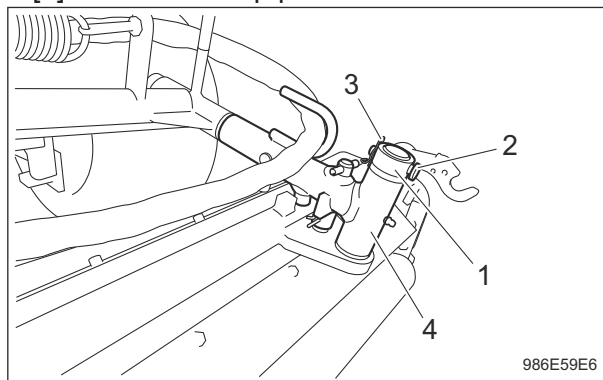

Installation of Verti Cutter #2·#3 (LS6 Installed Type)_002

1	Collar
2	Flat-head pin
3	Snap pin
4	Mower connecting fitting

Handling Instructions

Important

When installing the gear motor, apply sufficient grease to the motor shaft and the motor shaft mounting section on the vertical shaft side.

2. Install the gear motor.
 - [1] Install the packing and the gear motor.
 - [2] Tighten the bolts to secure the gear motor.

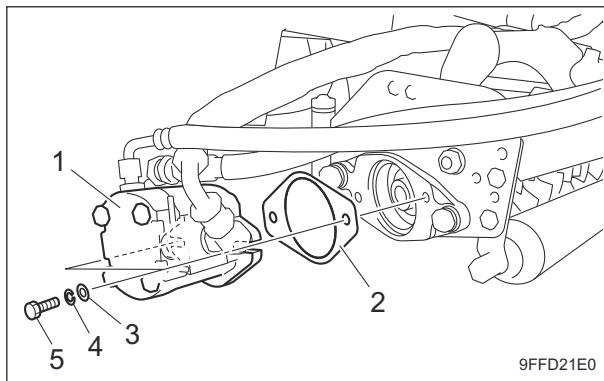

Installation of Verti Cutter #2·#3 (LS6 Installed Type)_003

1	Gear motor
2	Packing
3	Washer
4	Spring washer
5	Bolt

3. Make sure that the mower arm contacts the mower stopper.
 - [1] Start the engine.
 - [2] Raise the verti cutter.
 - [3] Stop the engine.
 - [4] Make sure that the mower arm contacts the mower stopper.

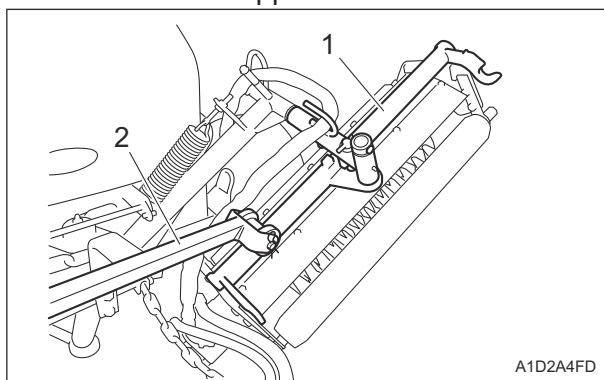

Installation of Verti Cutter #2·#3 (LS6 Installed Type)_004

1	Mower arm
2	Mower stopper

Removal of Verti Cutter #2·#3 (LS6 Installed Type)

1. Remove the gear motor.
 - [1] Remove the bolt, spring washer and washer.
 - [2] Remove the gear motor and packing.

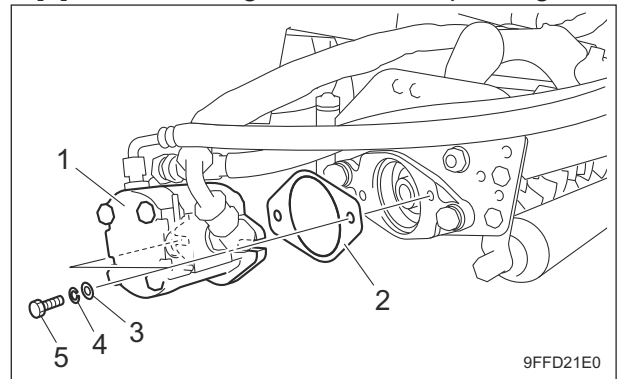

Removal of Verti Cutter #2·#3 (LS6 Installed Type)_001

1	Gear motor
2	Packing
3	Washer
4	Spring washer
5	Bolt

2. Remove the verti cutter.
 - [1] Remove the snap pin.
 - [2] Remove the flat-head pin.
 - [3] Remove the collar.
 - [4] Lift up the mower connecting fitting to remove the verti cutter.

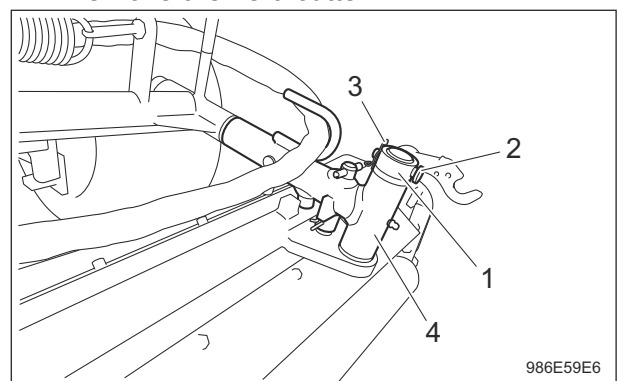

Removal of Verti Cutter #2·#3 (LS6 Installed Type)_002

1	Collar
2	Flat-head pin
3	Snap pin
4	Mower connecting fitting

Handling Instructions

LM351

Installation of Verti Cutter

Important

Apply sufficient grease to the mower connecting shaft when installing the mower arm to the mower connecting shaft.

References

■ #1: VM60

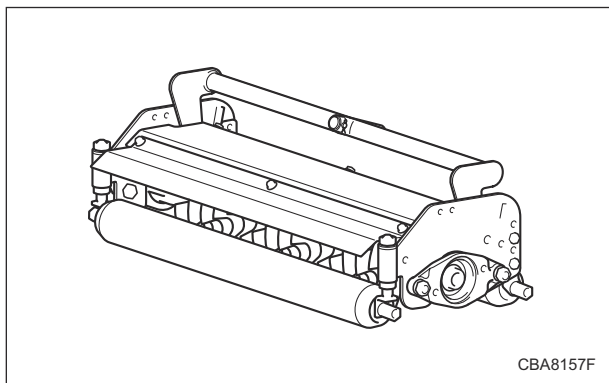

Installation of Verti Cutter_001

■ #2 • #3: VM66

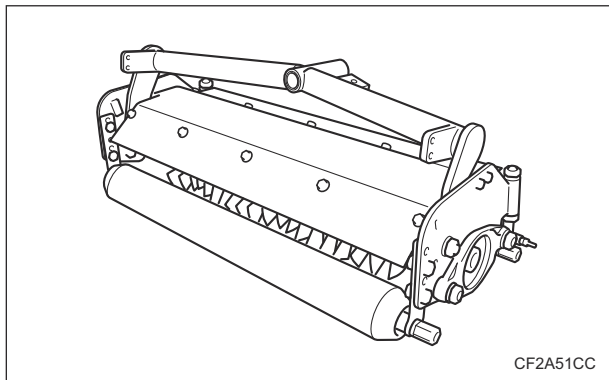

Installation of Verti Cutter_002

1. Install the verti cutter.

[1] Install the inner copper washer, iron washer, and copper washer onto the mower connecting shaft in this order.

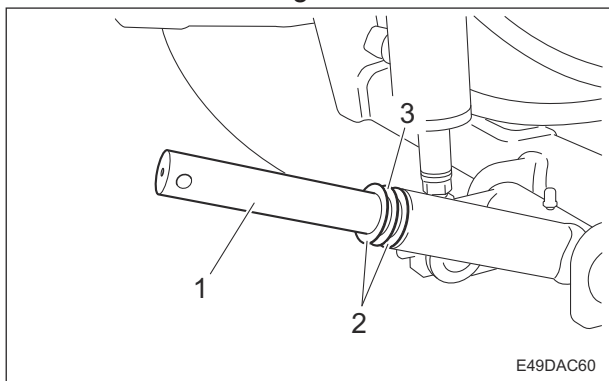

Installation of Verti Cutter_003

1	Mower connecting shaft
2	Copper washer
3	Iron washer

[2] Insert the mower arm into the mower connecting shaft.

[3] Install the outer copper washer, iron washer, and copper washer onto the mower connecting shaft in this order.

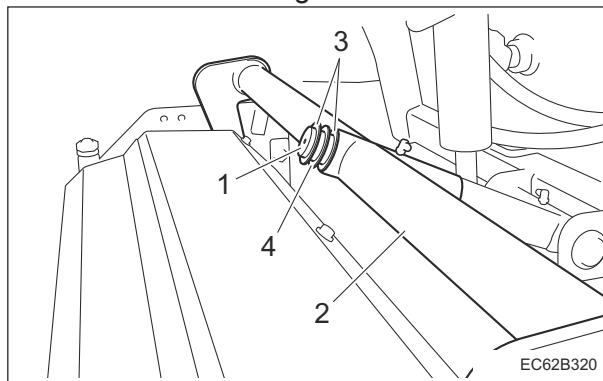

Installation of Verti Cutter_004

1	Mower connecting shaft
2	Mower arm
3	Copper washer
4	Iron washer

[4] Install the collar.

[5] Install the round-head pin.

[6] Install the snap pin.

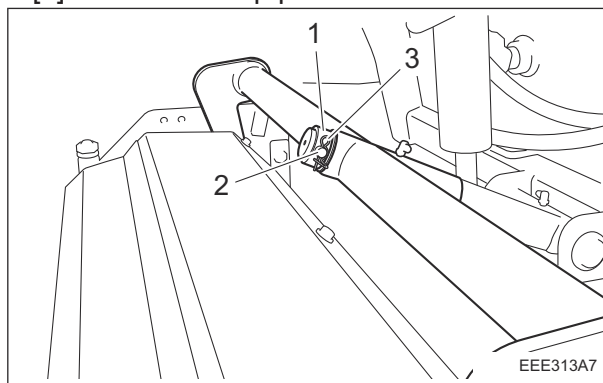

Installation of Verti Cutter_005

1	Collar
2	Round-head pin
3	Snap pin

Handling Instructions

Important

When installing the gear motor, apply sufficient grease to the motor shaft and the motor shaft mounting section on the vertical shaft side.

2. Install the gear motor.

- [1] Install the packing and the gear motor.
- [2] Tighten the bolts to secure the gear motor.

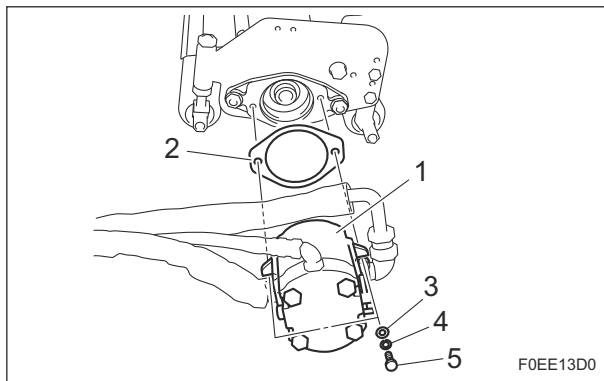

Installation of Verti Cutter_006

1	Gear motor
2	Packing
3	Washer
4	Spring washer
5	Bolt

3. Make sure that the mower arm of #1 contacts the mower stopper, and the mower arms of #2 and #3 do not interfere with the hydraulic hoses.

- [1] Start the engine.
- [2] Raise all the verti cutters.
- [3] Stop the engine.

- [4] Make sure that the mower arm of #1 contacts the mower stopper. If the mower arm does not contact the mower stopper, adjust the mower stopper. (Refer to "Adjustment of Mower Stopper" in the Owner's Operating Manual for the main vehicle.)

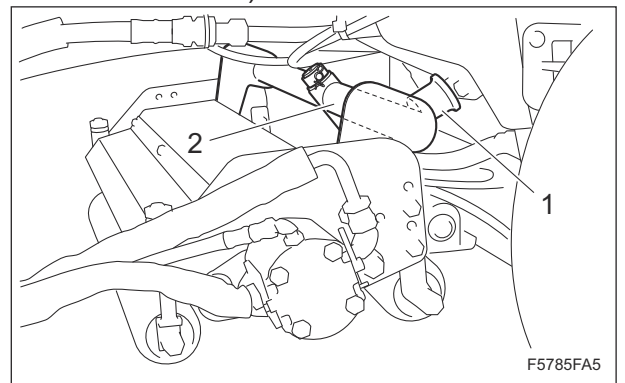

Installation of Verti Cutter_007

1	Mower stopper
2	Mower arm

- [5] Make sure that the mower arms of #2 and #3 do not interfere with the hydraulic hoses.

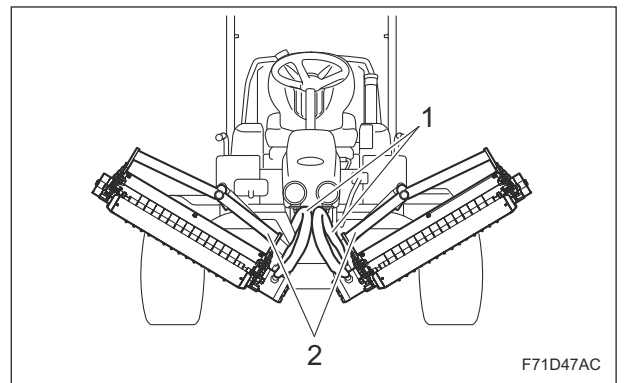

Installation of Verti Cutter_008

1	Hydraulic hose
2	Mower arm

Handling Instructions

Removal of Verti Cutter

1. Remove the gear motor.

[1] Remove the bolt, spring washer and washer.

[2] Remove the gear motor and packing.

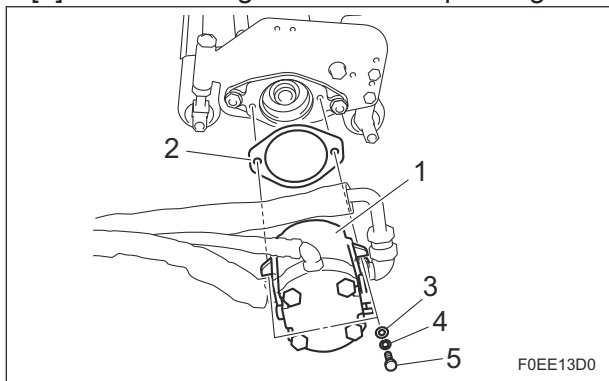

Removal of Verti Cutter_001

1	Gear motor
2	Packing
3	Washer
4	Spring washer
5	Bolt

2. Remove the verti cutter.

[1] Remove the snap pin.

[2] Remove the round-head pin.

[3] Remove the collar.

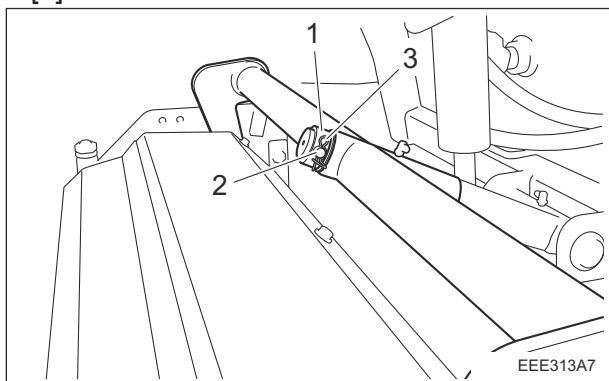

Removal of Verti Cutter_002

1	Collar
2	Round-head pin
3	Snap pin

[4] Remove the outer copper washers and iron washer from the mower connecting shaft.

[5] Pull out the mower arm from the mower connecting shaft to remove the verti cutter.

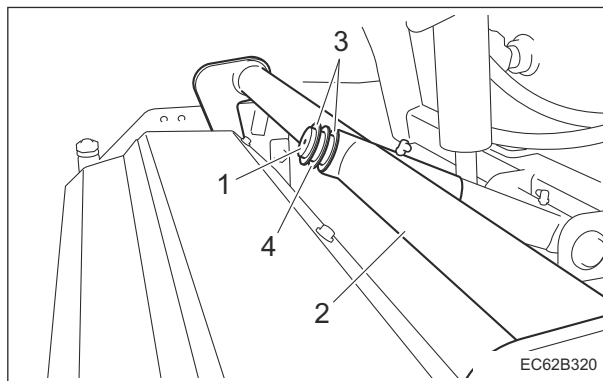

Removal of Verti Cutter_003

1	Mower connecting shaft
2	Mower arm
3	Copper washer
4	Iron washer

[6] Remove the inner copper washers and iron washer from the mower connecting shaft.

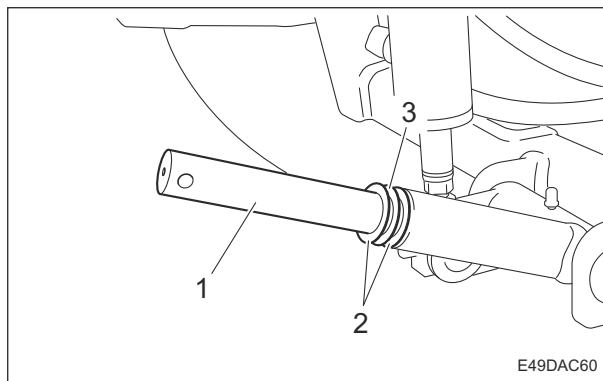

Removal of Verti Cutter_004

1	Mower connecting shaft
2	Copper washer
3	Iron washer

Handling Instructions

LM551 · LM551A · LM551B

Installation of Verti Cutter (LH6 Installed Type)

1. If a hose guide is installed, remove it from the hydraulic hose.

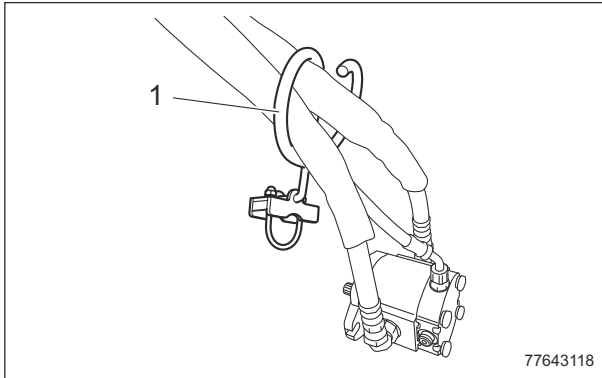

Installation of Verti Cutter (LH6 Installed Type)_001

1	Hose guide
---	------------

2. Remove the mower connecting fitting.

- [1] Remove the cotter pin.
- [2] Remove the flat-head pin.
- [3] Remove the mower connecting fitting and coil spring from the mower connecting shaft.

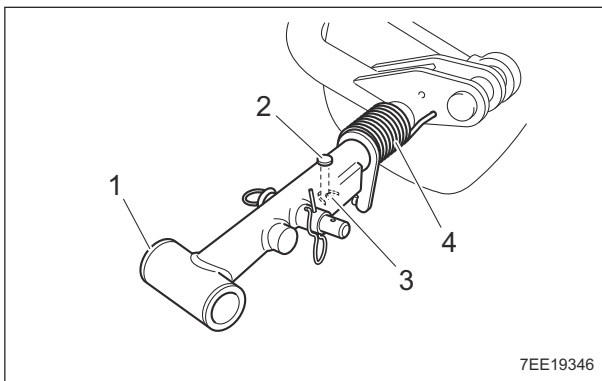

Installation of Verti Cutter (LH6 Installed Type)_002

1	Mower connecting fitting
2	Flat-head pin
3	Cotter pin
4	Coil spring

Important

Apply sufficient grease to the mower connecting shaft when installing the mower arm to the mower connecting shaft.

3. Install the verti cutter.

- [1] Align the direction of holes of the mower arm and the mower connecting shaft, and insert the mower arm into the mower connecting shaft.

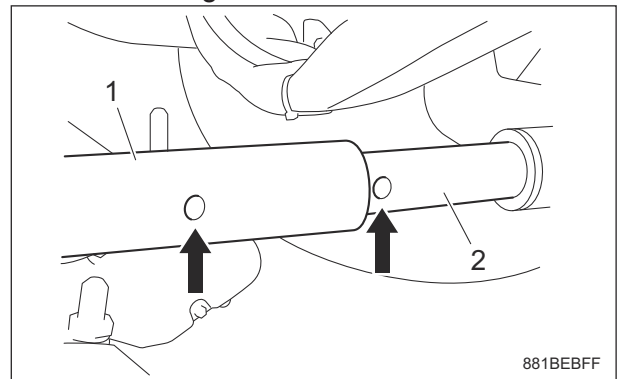

Installation of Verti Cutter (LH6 Installed Type)_003

1	Mower arm
2	Mower connecting shaft

- [2] Install the flat-head pin.

- [3] Install the cotter pin.

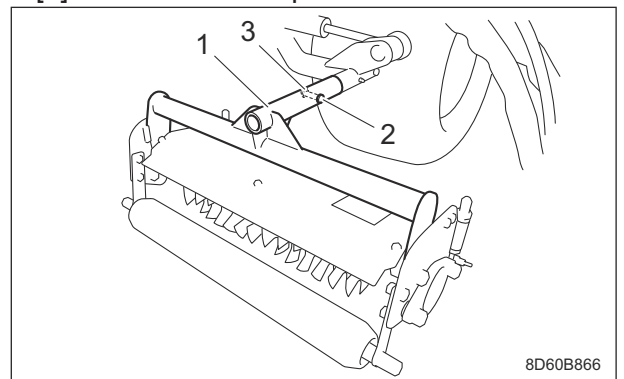

Installation of Verti Cutter (LH6 Installed Type)_004

1	Mower arm
2	Flat-head pin
3	Cotter pin

Important

When installing the gear motor, apply sufficient grease to the motor shaft and the motor shaft mounting section on the vertical shaft side.

4. Install the gear motor.

- [1] Install the packing and the gear motor.

Handling Instructions

[2] Tighten the bolts to secure the gear motor.

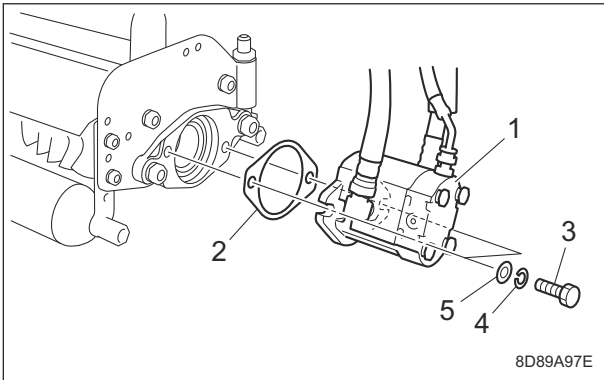

Installation of Verti Cutter (LH6 Installed Type)_005

1	Gear motor
2	Packing
3	Bolt
4	Spring washer
5	Washer

5. Adjust the mower stoppers for #1, #2 and #3.

[1] Start the engine.

[2] Raise the verti cutter.

[3] Stop the engine.

[4] Make sure that the mower arm contacts the mower stopper, and the verti cutter is level.

If the mower arm does not contact the mower stopper, adjust the mower stopper.

(Refer to "Adjustment of Mower Stopper" in the Owner's Operating Manual for the main vehicle.)

■#1

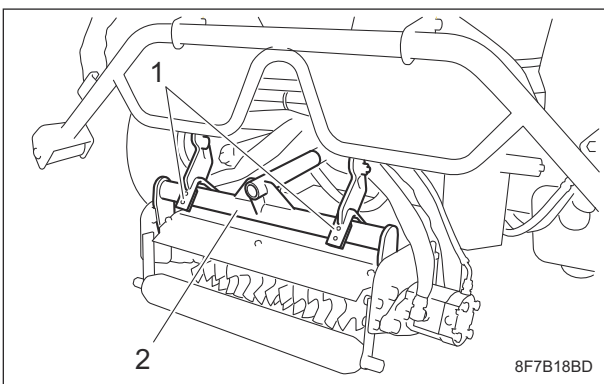

Installation of Verti Cutter (LH6 Installed Type)_006

1	Mower stopper
2	Mower arm

■#2 • 3

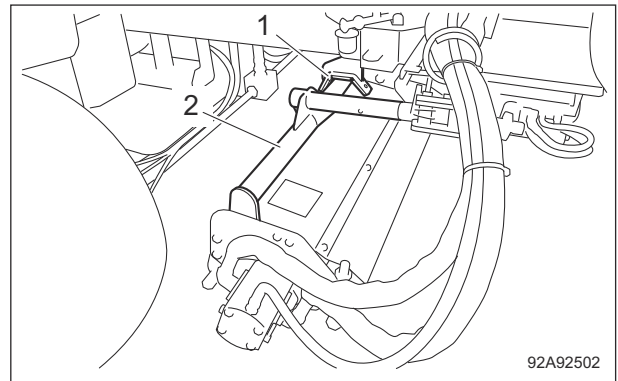

Installation of Verti Cutter (LH6 Installed Type)_007

1	Mower stopper
2	Mower arm

Removal of Verti Cutter (LH6 Installed Type)

1. Remove the gear motor.

[1] Remove the bolt, spring washer, and washer.

[2] Remove the gear motor and the packing.

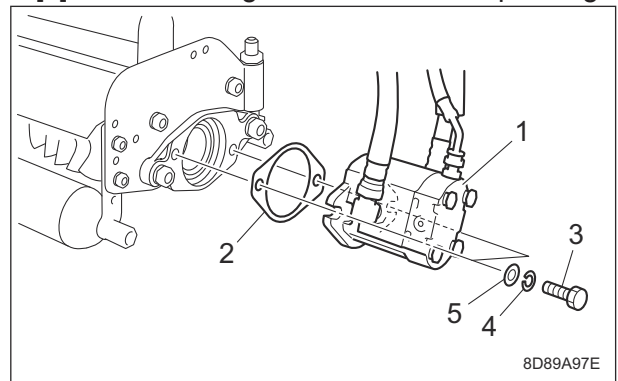

Removal of Verti Cutter (LH6 Installed Type)_001

1	Gear motor
2	Packing
3	Bolt
4	Spring washer
5	Washer

2. Remove the verti cutter.

[1] Remove the cotter pin.

[2] Remove the flat-head pin.

Handling Instructions

[3] Pull out the mower arm from the mower connecting shaft to remove the verti cutter.

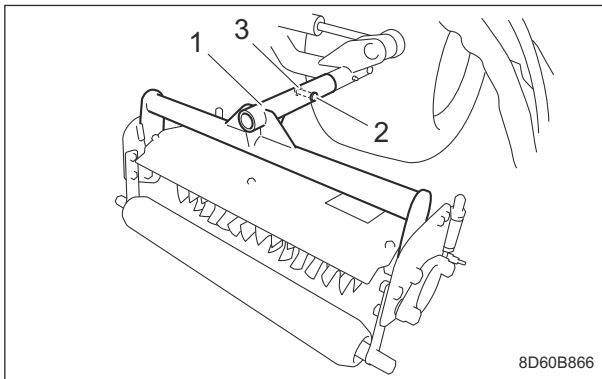

Removal of Verti Cutter (LH6 Installed Type)_002

1	Mower arm
2	Flat-head pin
3	Cotter pin

2. Install the verti cutter.

[1] Insert the mower arm into the mower connecting fitting.

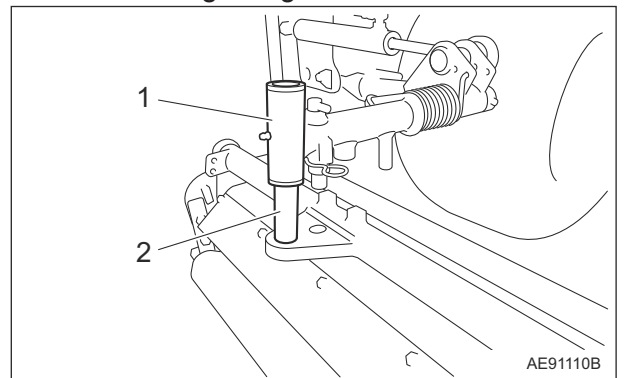

Installation of Verti Cutter (LS6 Installed Type)_002

1	Mower connecting fitting
2	Mower arm

Installation of Verti Cutter (LS6 Installed Type)

Caution

The mower connecting fitting is equipped with a coil spring. When installing the verti cutter, the return force of the spring may cause injury. Pay careful attention during installation.

Important

Apply sufficient grease to the mower arm when installing the mower arm to the mower connecting fitting.

1. If a hose guide is installed, remove it from the hydraulic hose.

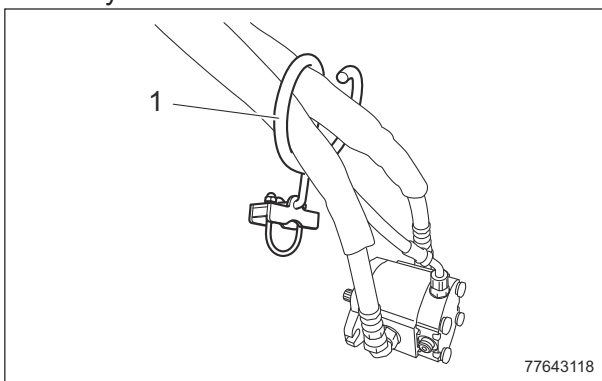

Installation of Verti Cutter (LS6 Installed Type)_001

1	Hose guide
---	------------

[2] Install the collar.

[3] Install the flat-head pin.

[4] Install the snap pin.

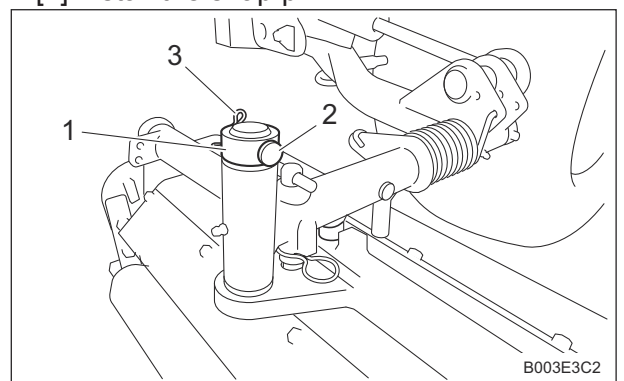

Installation of Verti Cutter (LS6 Installed Type)_003

1	Collar
2	Flat-head pin
3	Snap pin

Important

When installing the gear motor, apply sufficient grease to the motor shaft and the motor shaft mounting section on the vertical shaft side.

3. Install the gear motor.

[1] Install the packing and the gear motor.

Handling Instructions

[2] Tighten the bolts to secure the gear motor.

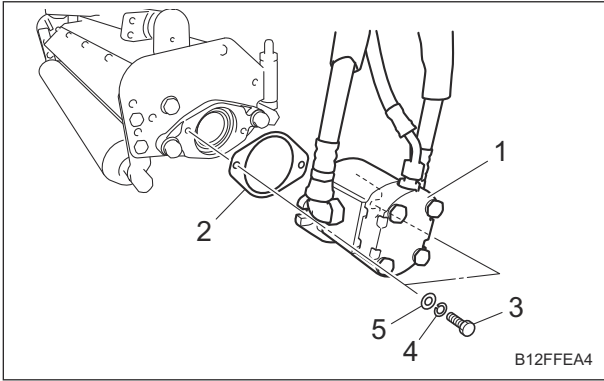

Installation of Verti Cutter (LS6 Installed Type)_004

1	Gear motor
2	Packing
3	Bolt
4	Spring washer
5	Washer

4. Adjust the mower stoppers for #1, #2 and #3.

[1] Start the engine.

[2] Raise the verti cutter.

[3] Stop the engine.

[4] Make sure that the mower arm contacts the mower stopper, and the verti cutter is level.

If the mower arm does not contact the mower stopper, adjust the mower stopper.

(Refer to "Adjustment of Mower Stopper" in the Owner's Operating Manual for the main vehicle.)

■#1

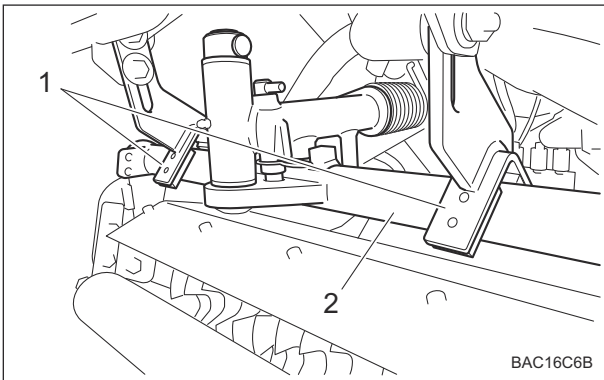

Installation of Verti Cutter (LS6 Installed Type)_005

1	Mower stopper
2	Mower arm

■#2 • 3

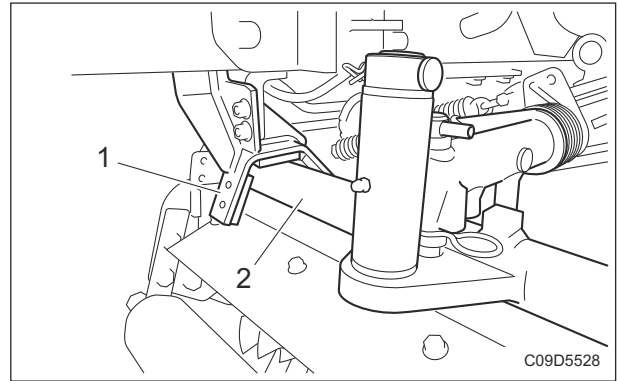

Installation of Verti Cutter (LS6 Installed Type)_006

1	Mower stopper
2	Mower arm

Removal of Verti Cutter (LS6 Installed Type)

⚠ Caution

The mower connecting fitting is equipped with a coil spring.

When removing the verti cutter, the return force of the spring may cause injury.

Pay careful attention during removal.

1. Remove the gear motor.

[1] Remove the bolt, spring washer, and washer.

[2] Remove the gear motor and packing.

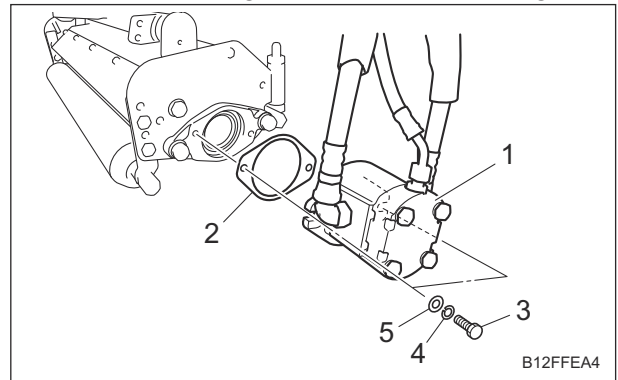

Removal of Verti Cutter (LS6 Installed Type)_001

1	Gear motor
2	Packing
3	Bolt
4	Spring washer
5	Washer

2. Remove the verti cutter.

[1] Remove the snap pin.

[2] Remove the flat-head pin.

Handling Instructions

[3] Remove the collar.

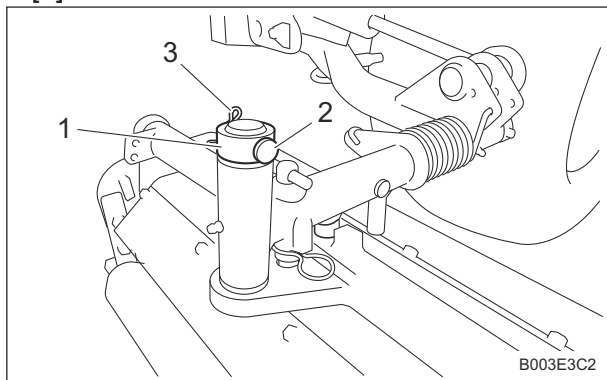

Removal of Verti Cutter (LS6 Installed Type)_002

1	Collar
2	Flat-head pin
3	Snap pin

[3] Remove the mower connecting fitting from the mower connecting shaft.

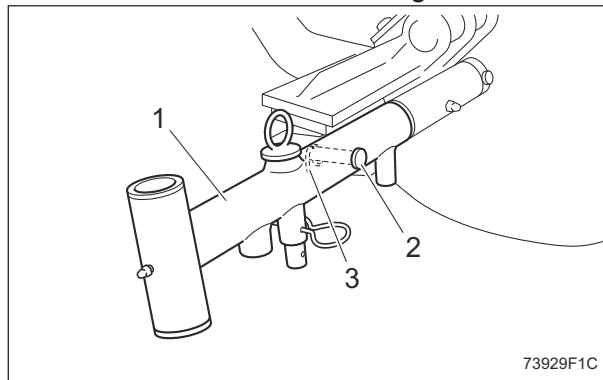

Installation of Verti Cutter_001

1	Mower connecting fitting
2	Flat-head pin
3	Cotter pin

[4] Pull out the mower arm from the mower connecting fitting to remove the verti cutter.

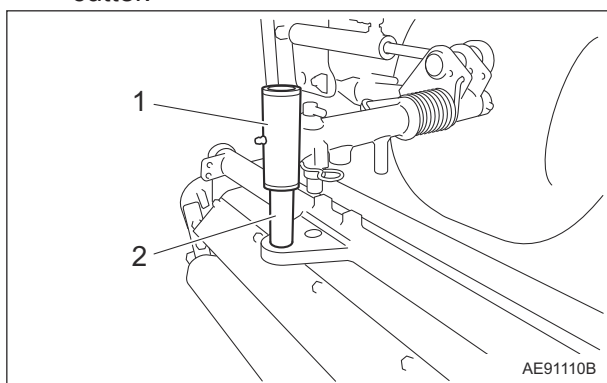

Removal of Verti Cutter (LS6 Installed Type)_003

1	Mower connecting fitting
2	Mower arm

Important

Apply sufficient grease to the mower connecting shaft when installing the mower arm to the mower connecting shaft.

2. Install the verti cutter.

[1] Align the direction of holes of the mower arm and the mower connecting shaft, and insert the mower arm into the mower connecting shaft.

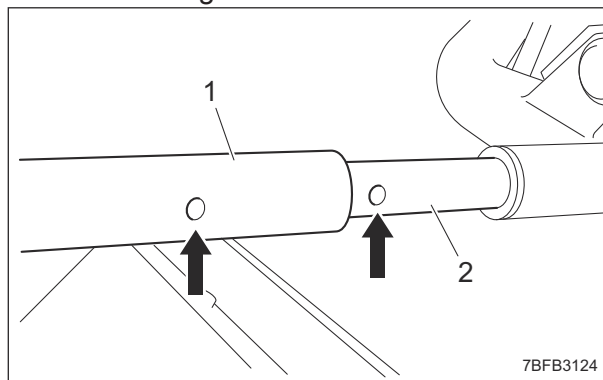

Installation of Verti Cutter_002

1	Mower arm
2	Mower connecting shaft

[2] Install the flat-head pin.

LM2700 • LM2710

Installation of Verti Cutter

1. Remove the mower connecting fitting.

[1] Remove the cotter pin.

[2] Remove the flat-head pin.

Handling Instructions

[3] Install the cotter pin.

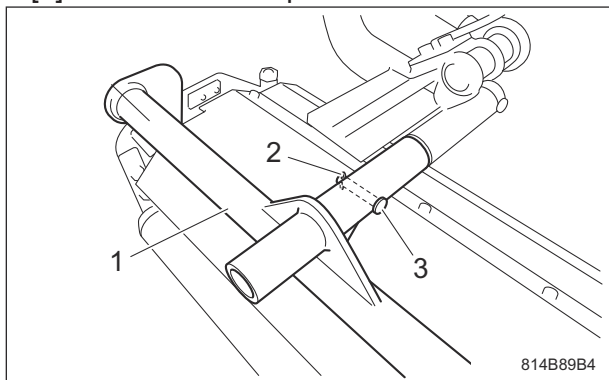

Installation of Verti Cutter_003

1	Mower arm
2	Flat-head pin
3	Cotter pin

Important

When installing the gear motor, apply sufficient grease to the motor shaft and the motor shaft mounting section on the vertical shaft side.

3. Install the gear motor.

- [1] Install the packing and the gear motor.
- [2] Tighten the bolts to secure the gear motor.

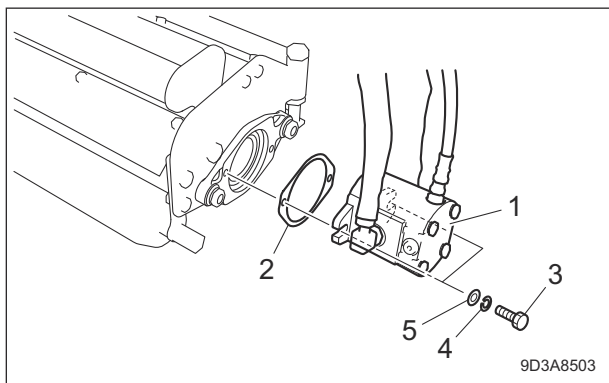

Installation of Verti Cutter_004

1	Gear motor
2	Packing
3	Bolt
4	Spring washer
5	Washer

4. Install the hose clamp. (#1 only)

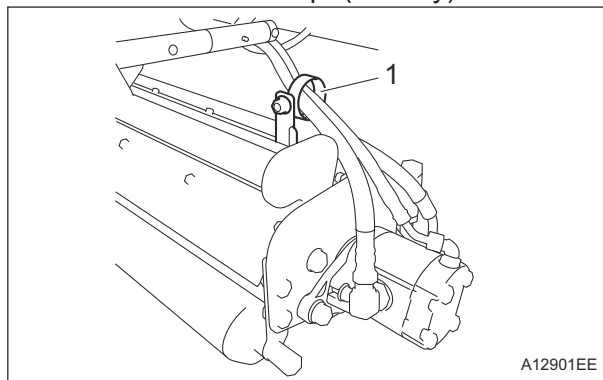

Installation of Verti Cutter_005

1	Hose clamp
---	------------

5. Make sure that the mower arms of #1, #2 and #3 contact the mower stoppers.

- [1] Start the engine.
- [2] Raise the verti cutter.
- [3] Stop the engine.
- [4] Make sure that the mower arm contacts the mower stopper, and the verti cutter is level.

If the mower arm does not contact the mower stopper, adjust the mower stopper.

(Refer to "Adjustment of Mower Stopper" in the Owner's Operating Manual for the main vehicle.)

■ #1

LH62

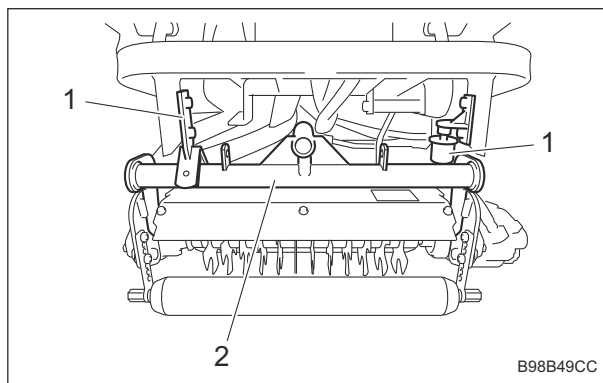

Installation of Verti Cutter_006

Handling Instructions

LH66

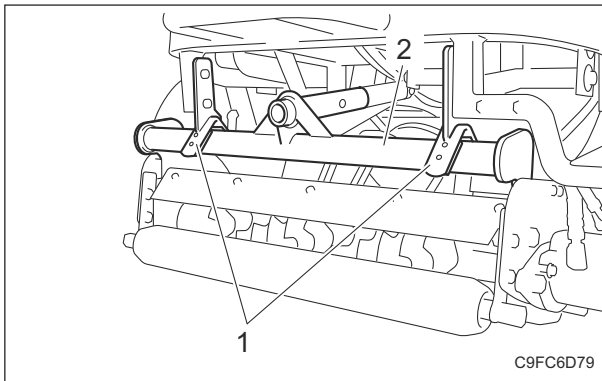

Installation of Verti Cutter_007

1	Mower stopper
2	Mower arm

■ #2 • 3

LH62

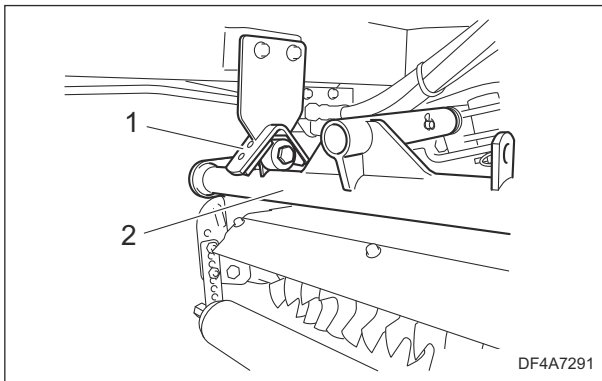

Installation of Verti Cutter_008

LH66

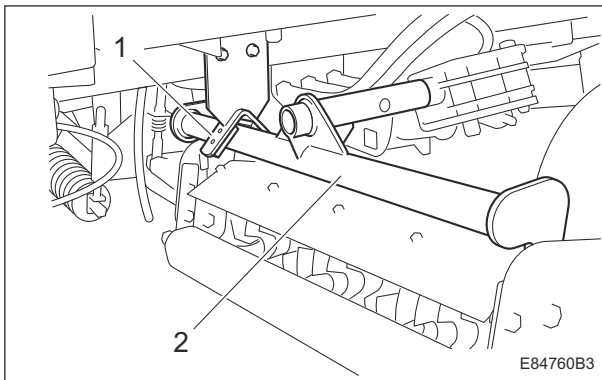

Installation of Verti Cutter_009

1	Mower stopper
2	Mower arm

Removal of Verti Cutter

1. Remove the hose clamp. (#1 only)

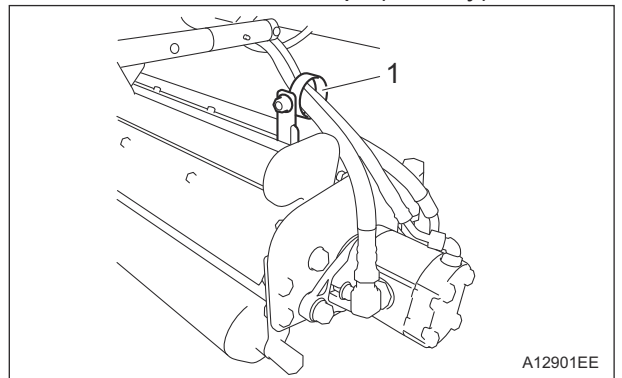

Removal of Verti Cutter_001

1	Hose clamp
---	------------

2. Remove the gear motor.

[1] Remove the bolt, spring washer, and washer.

[2] Remove the gear motor and the packing.

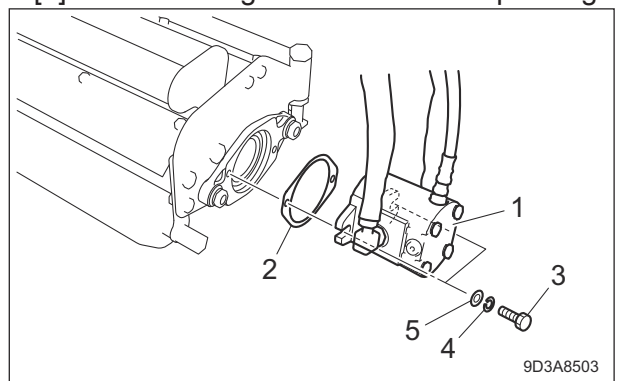

Removal of Verti Cutter_002

1	Gear motor
2	Packing
3	Bolt
4	Spring washer
5	Washer

3. Remove the verti cutter.

[1] Remove the cotter pin.

[2] Remove the flat-head pin.

Handling Instructions

Handling Instructions

[3] Pull out the mower arm from the mower connecting shaft to remove the verti cutter.

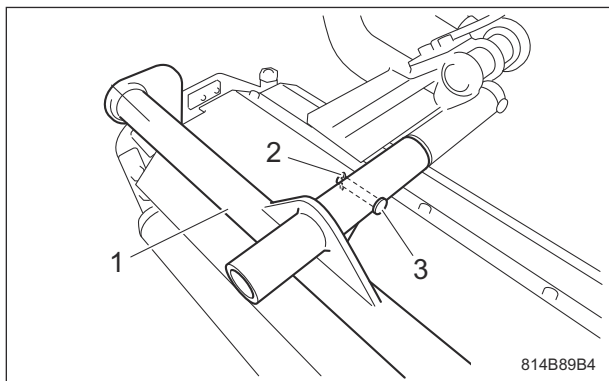

Removal of Verti Cutter_003

1	Mower arm
2	Flat-head pin
3	Cotter pin

LM3200 · LM3200C · LM3210 · LM3210A

Installation of Verti Cutter

1. Remove the mower connecting fitting.
(Type F only)

[1] Remove the cotter pin.

[2] Remove the round-head pin.

[3] Remove the mower connecting fitting from the mower connecting shaft.

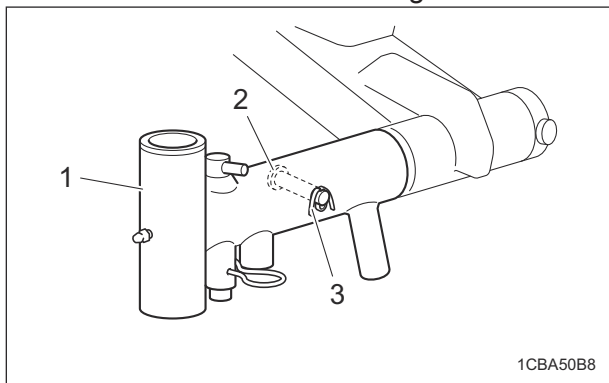

Installation of Verti Cutter_001

1	Mower connecting fitting
2	Round-head pin
3	Cotter pin

Important

Apply sufficient grease to the mower connecting shaft when installing the mower arm to the mower connecting shaft.

Important

When installing the mower arm to the mower connecting shaft, the position of the mounting hole of the mower arm differs between Type F and Type R.

2. Install the verti cutter.

[1] Align the direction of holes of the mower arm and the mower connecting shaft, and insert the mower arm into the mower connecting shaft.

■ Type F

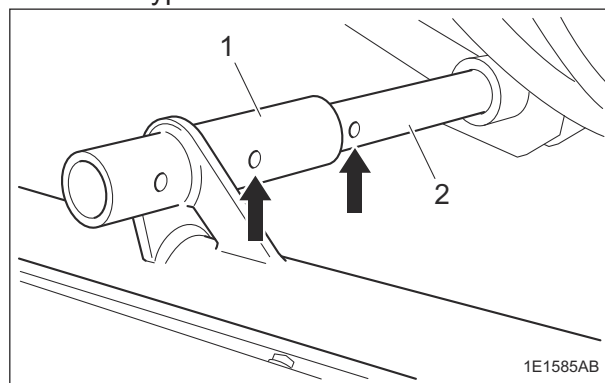

Installation of Verti Cutter_002

1	Mower arm
2	Mower connecting shaft

■ Type R

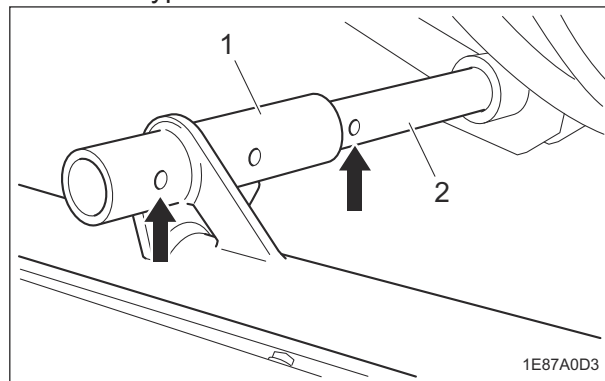

Installation of Verti Cutter_003

1	Mower arm
2	Mower connecting shaft

[2] Install the round-head pin.

Handling Instructions

[3] Install the cotter pin.

■ Type F

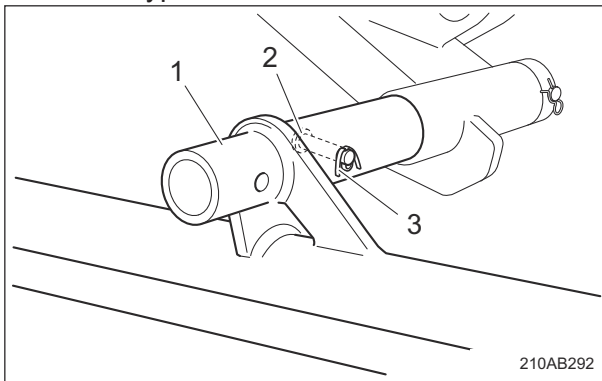

Installation of Verti Cutter_004

1	Mower arm
2	Round-head pin
3	Cotter pin

■ Type R

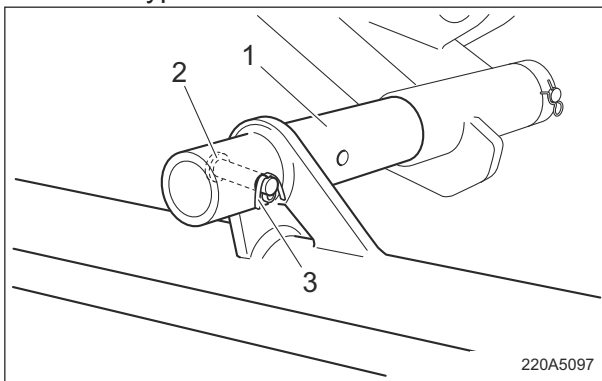

Installation of Verti Cutter_005

1	Mower arm
2	Round-head pin
3	Cotter pin

Important

When installing the gear motor, apply sufficient grease to the motor shaft and the motor shaft mounting section on the vertical shaft side.

3. Install the gear motor.

[1] Install the packing and the gear motor.

[2] Tighten the bolts to secure the gear motor.

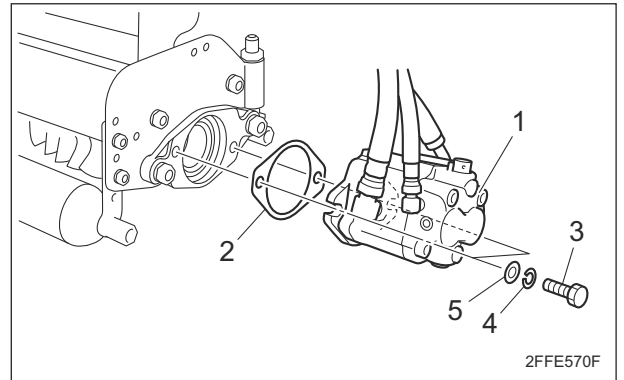

Installation of Verti Cutter_006

1	Gear motor
2	Packing
3	Bolt
4	Spring washer
5	Washer

4. Make sure that the mower arms of #1, #2 and #3 contact the mower stoppers.

[1] Start the engine.

[2] Raise the verti cutter.

[3] Stop the engine.

[4] Make sure that the mower arm contacts the mower stopper, and the verti cutter is level.

If the mower arm does not contact the mower stopper, adjust the mower stopper.

(Refer to "Adjustment of Mower Stopper" in the Owner's Operating Manual for the main vehicle.)

■ #1

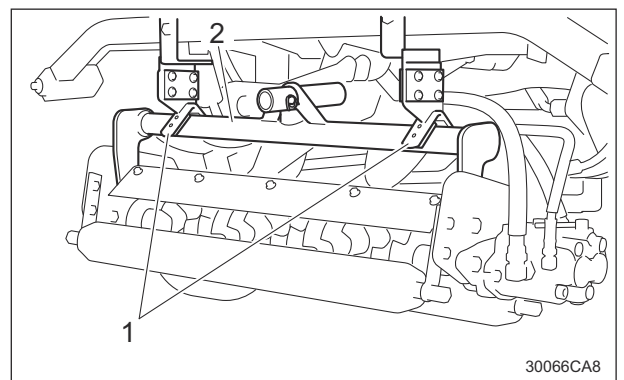

Installation of Verti Cutter_007

1	Mower stopper
2	Mower arm

Handling Instructions

■#2 • 3

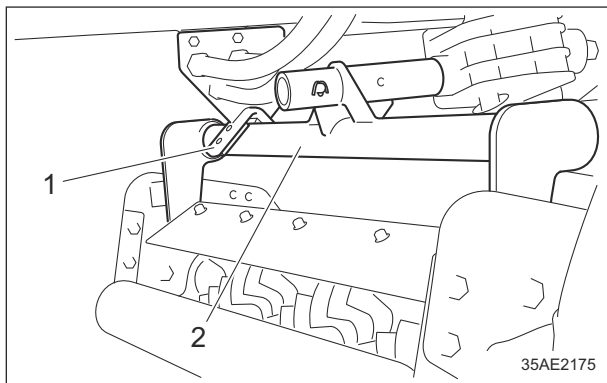

Installation of Verti Cutter_008

1	Mower stopper
2	Mower arm

[3] Pull out the mower arm from the mower connecting shaft to remove the verti cutter.

■Type F

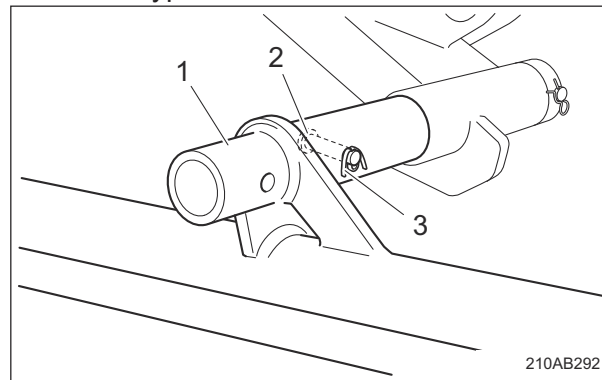

Removal of Verti Cutter_002

1	Mower arm
2	Round-head pin
3	Cotter pin

Removal of Verti Cutter

1. Remove the gear motor.

[1] Remove the bolt, spring washer and washer.

[2] Remove the gear motor and packing.

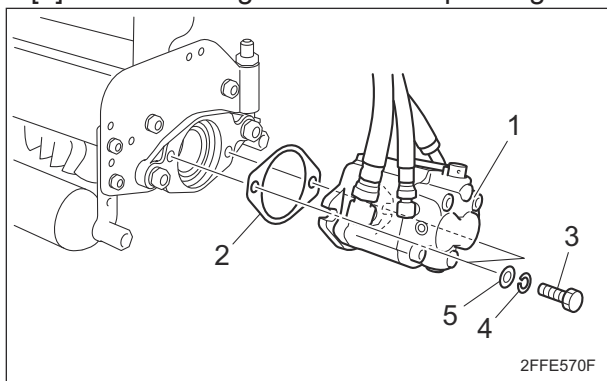

Removal of Verti Cutter_001

1	Gear motor
2	Packing
3	Bolt
4	Spring washer
5	Washer

■Type R

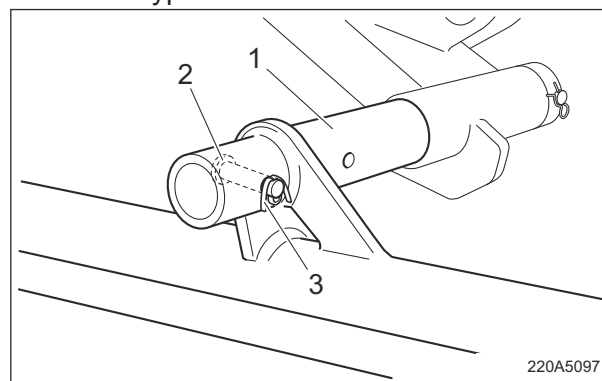

Removal of Verti Cutter_003

1	Mower arm
2	Round-head pin
3	Cotter pin

2. Remove the verti cutter.

[1] Remove the cotter pin.

[2] Remove the round-head pin.

Handling Instructions

Inspection before Use

The purpose of the machine inspection is to:

- Prevent accidents
- Prevent damage to the machine
- Maintain machine performance

Detecting machine malfunctions early helps prevent unexpected problems from occurring. If you detect any abnormalities with the machine, immediately perform maintenance or repairs.

Verti Cutter

Inspection of Vertical Blades

Caution

Wear gloves when touching edged tools to avoid cutting your hands.

1. Check to see whether or not the edge of the vertical blade is too blunt to cut.
2. Make sure that the vertical blade is not bent.
3. Make sure that the vertical blade is not chipped.
4. Check to see how much the vertical blade is worn.
5. Check to see whether or not the blade shaft has distortion.

Inspection of Rollers

1. Make sure that there is no abrasion nor adhesion of the roller.
2. Make sure that there is no wear of the roller shaft.
3. Make sure that there is no wear nor damage of the oil seal.
4. Make sure that there is no wear nor rust of the bearing.
5. Make sure that there is no play in the roller shaft.

Inspection of Covers

Warning

If you have removed a protective cover during inspection, be sure to securely install it in its original position.

If a protective cover remains removed, foreign objects may fly off, and the operator or the mechanic can be injured.

1. Make sure that there is no wear or deterioration of protective covers.
2. Make sure that there is no damage to protective covers.
3. Make sure that there is no interference with moving parts due to deformation of protective covers.
4. Make sure that protective covers are installed in their appropriate positions.

Inspection of Rear Scraper (Wire Type)

Note:

Depending on the specifications, this function may not be available.

1. Make sure that there are no breaks or sagging in the scraper (wire).
2. Make sure that there is no contact between the scraper and roller.

Inspection of Bolts and Nuts

Important

The bolts and nuts may be loosened at the earlier stage of the use.

Be sure to retighten or replace before operating the machine whenever there is any abnormality.

1. Check the bolts and nuts for looseness and coming off.
2. Check the bolts and nuts for cracks and damages.
3. Check the bolts and nuts for rust.
4. Check around the bolts and nuts for traces of rust fluid.
5. Check for unequal bolt length.
6. Check the bolts and nuts for stripped threads and abrasion.

Handling Instructions

Operations

Vertical Cutting Procedure

⚠ Caution

Cutting work must be performed at an appropriate speed for the site and location. When cutting bumpy surfaces, keep the engine rpm steady, and slow down the speed of the main vehicle.

⚠ Caution

Please note that if you stop operating the mower unit up/down lever before the verti cutters are raised completely, vertical blade rotation may not stop. Vertical blade rotation will be turned on or off depending on the sensor-detected position of the verti cutters.

Important

Perform vertical cutting work with the mower unit up/down lever shifted to the "DOWN" position. Vertical blade rotation will stop if the mower unit up/down lever is shifted to the "NEUTRAL" or "UP" position.

Important

Do NOT start to move or stop the machine abruptly. It will damage the hydraulic system or result in oil leakage.

LM331

1. Shift the reel rotation/stop switching levers of all verti cutters to the "Rotation" position.
2. Start the engine.
3. Rev up the engine to the maximum rpm.
4. Release the lock for the brake pedal.
5. Shift the mower unit up/down lever to the "DOWN" position to lower the mower units.
6. Set the reel rotation switch to the "Rotation" position to rotate the vertical blades of all verti cutters.
7. Depress the traveling pedal to start cutting work.

Note:

During the work, the vertical blades will rotate or stop in sync with the up and down motion of the verti cutters.

LM351

1. Shift the reel rotation/stop switching levers of all verti cutters to the "Rotate" position.
2. Set the pedal stopper to the "Working" position.
3. Start the engine.
4. Rev up the engine to MAX.
5. Release the lock for the brake pedal.
6. Right before starting cutting work, set the anti-falling stop valve to the "Open" position.
7. Lower the verti cutters.
8. Set the reel rotation switch to the "Rotate" position to rotate the vertical blades of all verti cutters.
9. Depress the traveling pedal to start cutting work.

Note:

During the work, the vertical blades will rotate or stop in sync with the up and down motion of the verti cutters.

LM551 • LM551A • LM551B

1. Release the mower lock levers (latches) for verti cutters #4 and #5 just before cutting work.
2. Shift the reel rotation/stop switching levers of all verti cutters to the "Rotation" position.
3. Set the pedal stopper to the "Working" position.
4. Start the engine.
5. Rev the engine up to the maximum rpm.
6. Release the lock for the brake pedal.
7. Set the traveling/working selector switch to the "Working" position.
8. Shift the mower unit up/down lever to the "Down" position to lower the verti cutters.

Handling Instructions

- Set the reel rotation switch to the "Rotation" position to rotate the vertical blades of all verti cutters.

Important

When the traveling speed exceeds 12.0 km/h during vertical cutting operation, a buzzer will sound.

If the operation continues, the engine and hydraulic equipment will be damaged.

- Depress the traveling pedal to start cutting work.

Note:

During the work, the vertical blades will rotate or stop in sync with the up and down motion of the verti cutters.

LM2700 • LM2710

- Release the mower lock levers (latches) for verti cutters #4 and #5 just before cutting work.
- Shift the reel rotation/stop switching levers of all verti cutters to the "Rotation" position.
- Start the engine.
- Rev the engine up to the maximum rpm.
- Release the lock for the brake pedal.
- Set the 2WD/4WD selector switch to the "4WD" position.
- Set the traveling/working selector switch to the "Working" position.
- Shift the mower unit up/down lever to the "Down" position to lower the verti cutters.
- Set the reel rotation switch to the "Rotation" position to rotate the vertical blades of all verti cutters.
- Depress the traveling pedal to start cutting work.

Note:

During the work, the vertical blades will rotate or stop in sync with the up and down motion of the verti cutters.

LM3200 • LM3200C • LM3210 • LM3210A

- Release the mower lock levers (latches) for verti cutters #4 and #5 just before cutting work.
- Shift the reel rotation/stop switching levers of all verti cutters to the "Rotation" position.
- Start the engine.
- Rev the engine up to the maximum rpm.

- Release the lock for the brake pedal.
- Set the 2WD/4WD selector switch to the "4WD" position.
- Shift the mower unit up/down lever to the "Down" position to lower the verti cutters.
- Set the reel rotation switch to the "Rotation" position to rotate the vertical blades of all verti cutters.
- Depress the traveling pedal to start cutting work.

Note:

During the work, the vertical blades will rotate or stop in sync with the up and down motion of the verti cutters.

Cleaning after Use

The purpose of the machine cleaning is to:

- Prevent accidents
- Prevent damage to the machine
- Maintain machine performance

Properly clean the machine to maintain its functionality and performance.

If you detect any abnormalities with the machine, immediately perform maintenance or repairs.

Verti Cutter

Cleaning of Verti Cutter

Be sure to clean the verti cutter after use.

- Stop the engine.
- Carefully clean the inside and outside of the verti cutter with water or compressed air.
- Remove any grass wrapped around the vertical blades.

Handling Instructions

Storage

Short-Term Storage

Short-term storage means that the machine is temporarily stored (within 1 month) without use.

Follow the instructions below for short-term storage of the machine.

1. Cleaning
 - Remove dirt, grass clippings, oil stains etc. completely.
2. Verti cutter
 - Set the cutting depth to which the vertical blades do not touch the ground.
3. Storage location
 - Cover the machine and store it in a dry place where it will not be exposed to rain.

- Precautions for MaintenancePage 5-2**
- Greasing Page 5-2**
 - About GreasingPage 5-2
 - Greasing Points Page 5-2
- Adjustment and Replacement Page 5-4**
 - Verti CutterPage 5-4
- Storage Page 5-8**
 - Long-Term StoragePage 5-8

Maintenance

Precautions for Maintenance

Warning

The chapter "Maintenance" in this manual describes practical measures which should be performed by a mechanic with expertise. The owner should instruct the mechanic with expertise to perform maintenance service for this machine.

Caution

First, learn well the operations you plan to perform.

Important

Use tools appropriate for each operation.

Important

Use Baronesse genuine parts for replacement and accessories. Our product warranty may be void if you use non-genuine parts for replacement or accessories.

Greasing

About Greasing

Since there may be adhesion or damage due to lack of grease on moving parts, they must be greased.

Add urea-based No. 2 grease in accordance with the Maintenance Schedule.

Other locations where the specified grease or lubricant is used are indicated in "Greasing Points".

Add grease using the specified grease or lubricant.

Greasing Points

Grease nipples are installed in the following locations.

Add grease every 50 hours of operation. However, for locations where a time is specified, add grease according to that schedule.

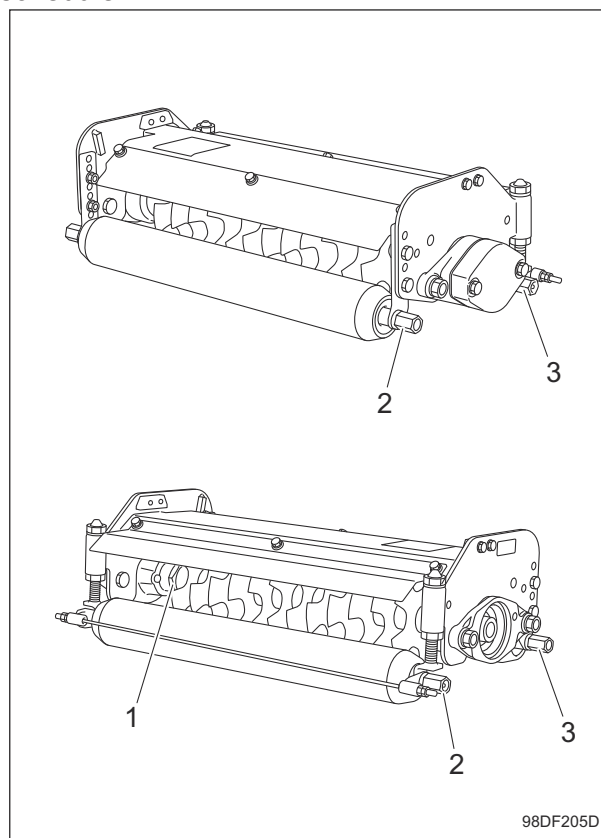

Greasing Points_001

	Location	No. of greasing points
1	Housing	1
2	Front roller shaft	2
3	Rear roller shaft	2

1. Housing

There is one point on the reel housing side.

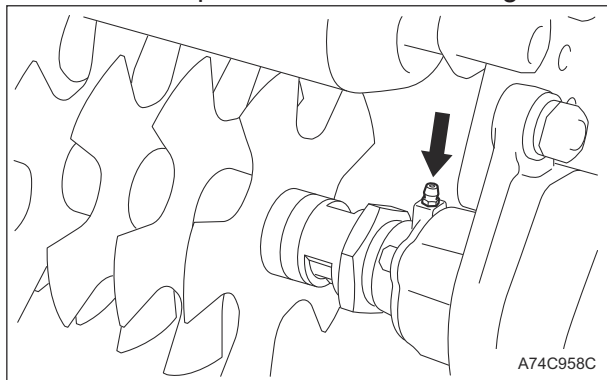

A74C958C

Greasing Points_002

2. Front roller shaft

There is one point each on the left and right of the front roller shaft.

Left end of front roller

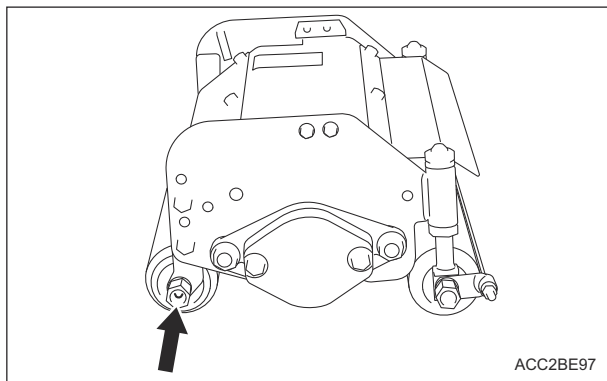

ACC2BE97

Greasing Points_003

Right end of front roller

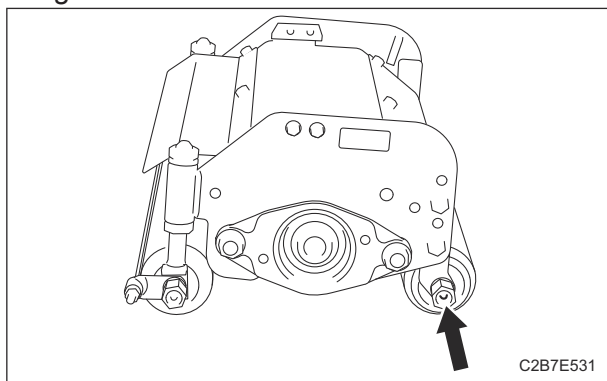

C2B7E531

Greasing Points_004

3. Rear roller shaft

There is one point each on the left and right of the rear roller shaft.

Left end of rear roller

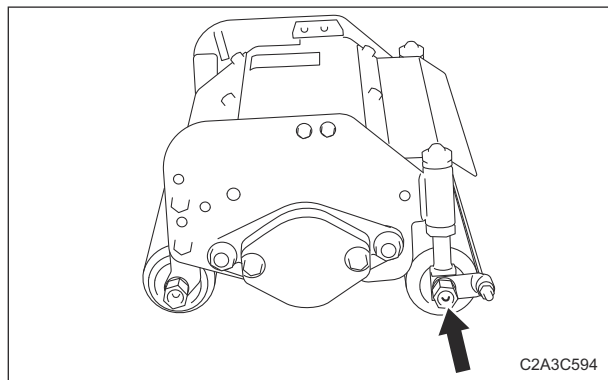

C2A3C594

Greasing Points_005

Right end of rear roller

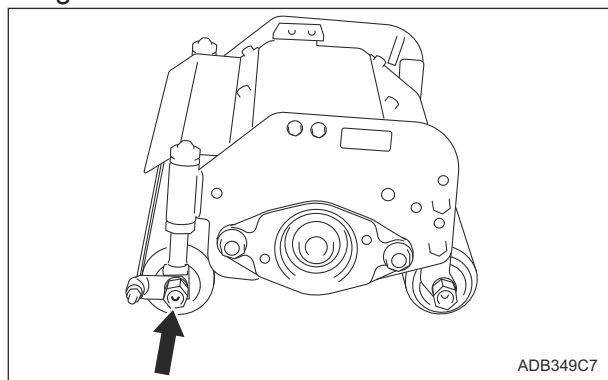

ADB349C7

Greasing Points_006

Maintenance

Adjustment and Replacement

Verti Cutter

Adjustment of Cutting Depth

Caution

Vertical blades are edged tools. Handle them carefully, since they could cut your hands or legs.

Important

The standard cutting depth is 0 - 6 mm (0 - 0.24 in). The setting deeper than 6 mm (0.24 in) will cause damage to the blades and the machine.

Important

The cutting depth values show rough indications. They may not be the same as the actual depth.

The cutting depth can be adjusted by changing the height of rear roller.

1. Stand the verti cutter Assy with the rear roller facing upward.
2. Bring the gauge (accessory) into contact with the front roller and rear roller at the left or right end of the verti cutter.

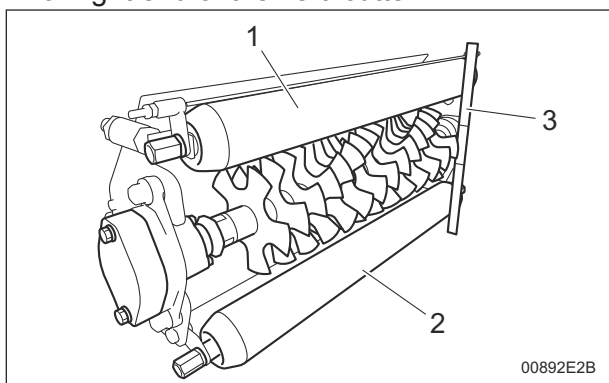

Adjustment of Cutting Depth_001

1	Rear roller
2	Front roller
3	Gauge

3. Adjust the cutting depth to the desired position by using the scale of the gauge.

[1] Choose the cutting depth by applying the vertex of the arc of the vertical blade to the scale of the gauge.

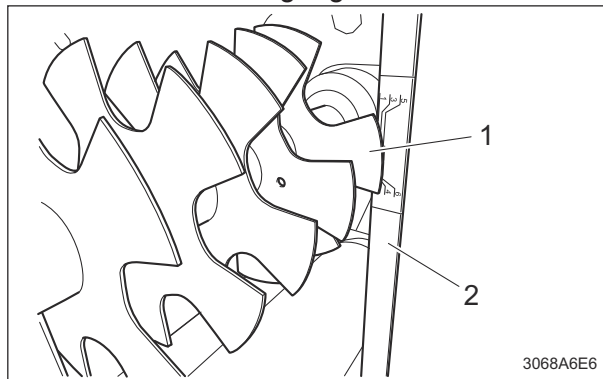

Adjustment of Cutting Depth_002

1	Vertical blade
2	Gauge

[2] Loosen the adjustment nut A, and use the adjustment nut B to move the rear roller up and down.

- To decrease the cutting depth: Tighten the adjustment nut B, and lower the position of the rear roller.
- To increase the cutting depth: Loosen the adjustment nut B, and raise the position of the rear roller.

[3] Firmly tighten the adjustment nut A.

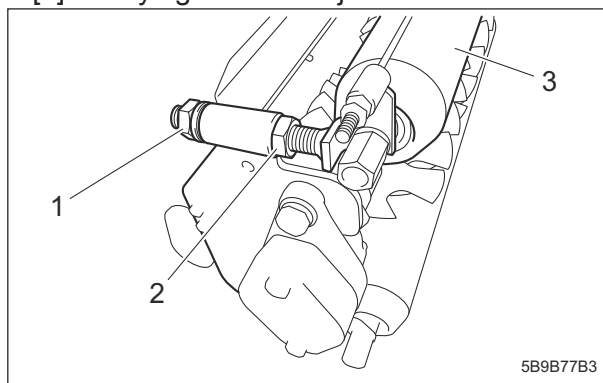

Adjustment of Cutting Depth_003

1	Adjustment nut A
2	Adjustment nut B
3	Rear roller

4. Repeat the same procedure at the end of the opposite side of the verti cutter (left or right end) for the adjustment of cutting depth.

- Bring the gauge into contact with the front roller and rear roller at the left and right ends of the verti cutter again to check the cutting depth is at the required position.

Important

If the vertical blade is less than the usage limit, replace it with a new one. The diameter of the vertical blade 145 mm (5.71 in) is the criterion for replacing the vertical blade. (When working with the maximum depth of 6 mm (0.24 in)) However, this criterion is only a reference and do not guarantee performance like that of a new vertical blade.

Note:

If the vertical blade is worn out and the cutting depth cannot be adjusted by the height of the rear roller, change the position of the front roller to increase the adjustment range. Change the mounting position of the roller bracket depending on the diameter of the vertical blade.

Front roller position	Vertical blade diameter
A	155 - 165 mm (6.10 - 6.50 in)
B	145 - 155 mm (5.71 - 6.10 in)

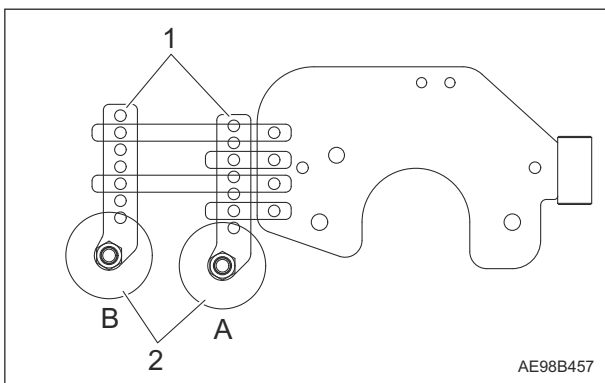

Adjustment of Cutting Depth_004

1	Roller bracket
2	Front roller

Adjustment of Rear Scraper (Wire Type)

Note:

Depending on the specifications, this function may not be available.

Important

Do not place the scraper in contact with the rear roller too tightly. It will cause the scraper break and slack.

The scraper prevents grass clippings, etc., from attaching to the rear roller.

- Loosen the left and right lock nuts and nuts of the scraper.
- Adjust the scraper so that there is a clearance of 2 to 3 mm (0.079 to 0.118 in) between it and the rear roller, and then secure it with the lock nuts.

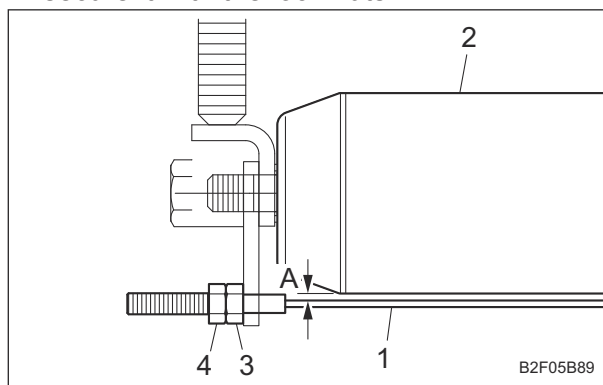

Adjustment of Rear Scraper (Wire Type)_001

1	Scraper
2	Rear roller
3	Nut
4	Lock nut
A	2 - 3 mm (0.079 - 0.118 in)

Maintenance

Replacement of Vertical Blade

Warning

Be sure to stop the engine before change of the vertical blades.

Caution

The vertical blade is an edged tool. Take extra care in handling since they could cut your hands or legs.

Caution

When touching edged tools, wear gloves, since they could cut your hands.

Important

Replace all vertical blades.

■ Removal of Vertical Blade

1. Stand the verti cutter Assy with the rear roller facing upward.
2. Remove the bolt for the reel housing cover.
3. Remove the reel housing cover.

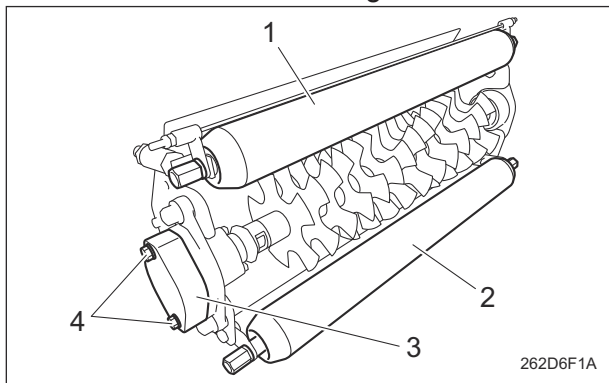

Removal of Vertical Blade_001

1	Rear roller
2	Front roller
3	Reel housing cover
4	Bolt

4. Pull out the cotter pin.

5. Remove the slotted special nut.

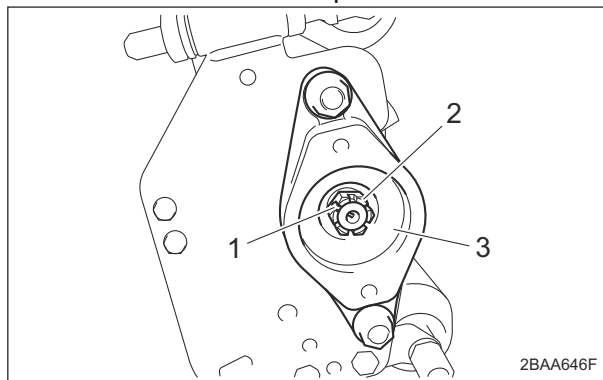

Removal of Vertical Blade_002

1	Cotter pin
2	Slotted special nut
3	Reel housing

6. Remove the nuts and bolts on the housing for both sides (reel housing and hydraulic motor housing).

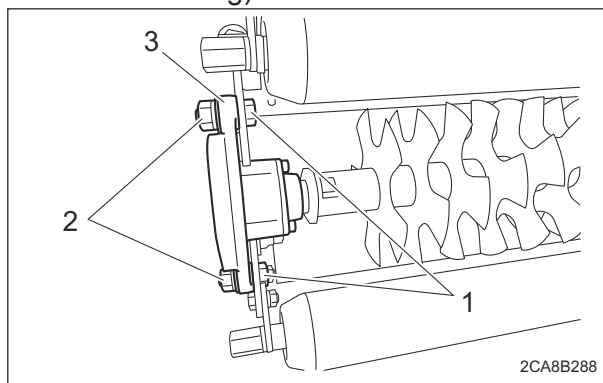

Removal of Vertical Blade_003

1	Bolt
2	Nut
3	Reel housing

7. Remove the vertical blade Assy from the frame.

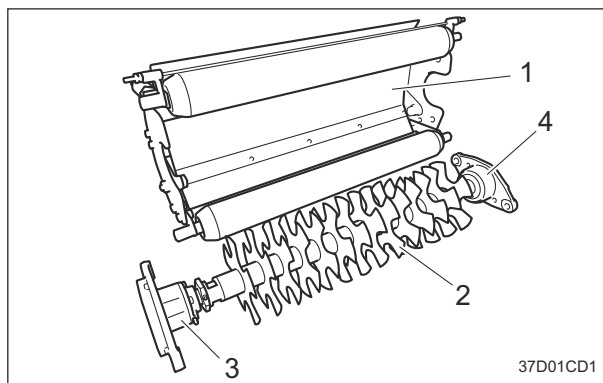

Removal of Vertical Blade_004

1	Frame
2	Vertical blade Assy
3	Reel housing
4	Hydraulic motor housing

8. Disassemble the vertical blade Assy.

- [1] Tap the reel housing with a plastic hammer to remove it.
- [2] Loosen the hollow screw and remove the hex nut.
- [3] Remove the end collar.
- [4] Remove the vertical blades and collars.

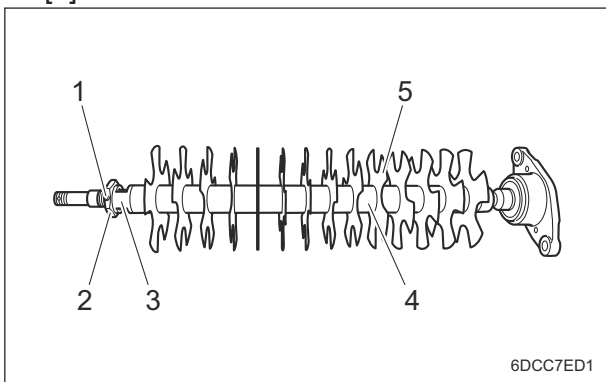

Removal of Vertical Blade_005

1	Hollow screw
2	Hex nut
3	End collar
4	Collar
5	Vertical blade

■ Installation of Vertical Blade

1. Assemble the vertical blade Assy.

- [1] Stand up the blade shaft with the hydraulic motor housing at the bottom.
- [2] Install a collar A and a vertical blade.

Note:

The number of collar A (the closest collar to the hydraulic motor housing) differs depending on the verti cutter.

- [3] Rotate the blade shaft counterclockwise by one of its six sides, and install a collar B and a vertical blade. Each time inserting one vertical blade into the blade shaft, rotate the blade shaft counterclockwise by one of its six sides.

Using the position of the hole in the blade as a guide, shift the position of the hole by 60 degrees to arrange the blade tips in a spiral.

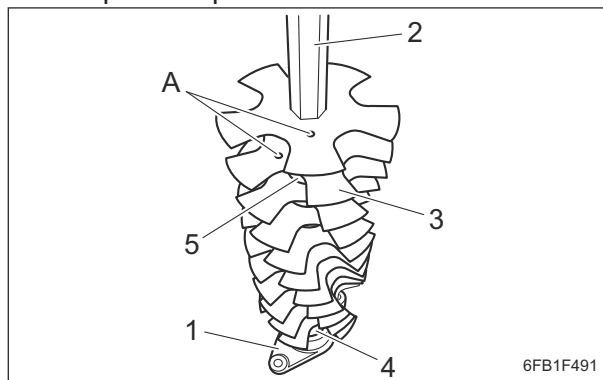

Installation of Vertical Blade_001

1	Hydraulic motor housing
2	Blade shaft
3	Vertical blade
4	Collar A
5	Collar B
A	Hole

- [4] Install the end collar.

- [5] Install the hex nut.

Important

Install the reel housing with the position of the grease nipple to the front roller side.

- [6] Firmly tighten the hollow screw.

- [7] Install the reel housing.

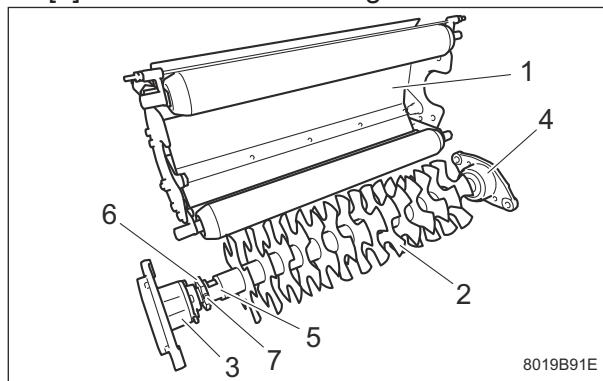

Installation of Vertical Blade_002

Maintenance

1	Frame
2	Vertical blade Assy
3	Reel housing
4	Hydraulic motor housing
5	End collar
6	Hex nut
7	Hollow screw

2. Install the vertical blade Assy to the frame.
3. Install the nuts and bolts on the housing for both sides (reel housing and hydraulic motor housing).

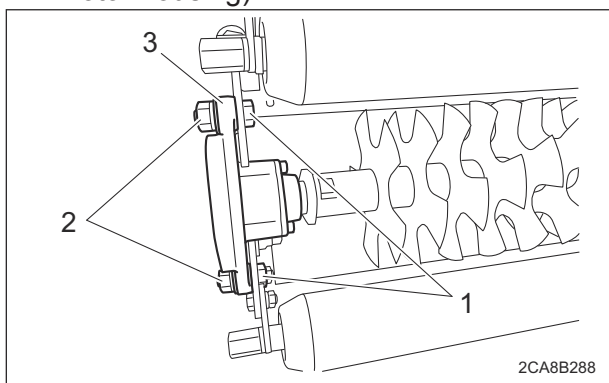

Installation of Vertical Blade_003

1	Bolt
2	Nut
3	Reel housing

4. Install the slotted special nut.
5. Insert the cotter pin.

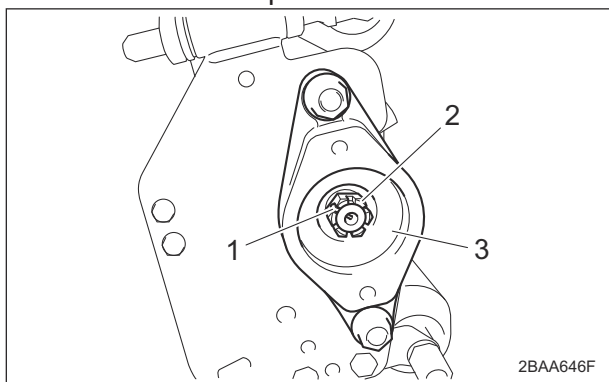

Installation of Vertical Blade_004

1	Cotter pin
2	Slotted special nut
3	Reel housing

6. Install the reel housing cover.

7. Install the bolt for the reel housing cover.

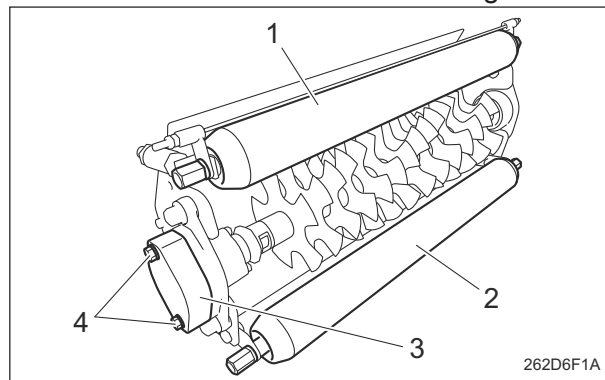

Installation of Vertical Blade_005

1	Rear roller
2	Front roller
3	Reel housing cover
4	Bolt

Storage

Long-Term Storage

Follow the instructions below for long-term storage of the machine.

1. Cleaning
 - Remove dirt, grass clippings, oil stains etc. completely.
2. Oil filling
 - Grease and lubricate the appropriate points.
3. Verti cutter
 - Set the cutting depth to which the vertical blades do not touch the ground.
4. Storage location
 - Cover the machine and store it in a dry place where it will not be exposed to rain.

Appended Table

Tightening TorquesPage 6-2
 Standard Tightening TorquesPage 6-2

Daily Check List Page 6-4

Maintenance Schedule Page 6-4

List of Adjusted Values Page 6-4

Appended Table

Tightening Torques

Important

Refer to the Tightening Torque table.
Note that the Baroness product warranty may not apply to defects caused by incorrect or overtorque tightening, etc.

Standard Tightening Torques

Bolts and Nuts

Important



A number of bolts are used in each part of this machine.
Be sure to re-tighten the bolts and nuts, because they may be loosened at the earlier stage of the use.

- As to the bolts and nuts without any special instruction, tighten them in appropriate tightening torque with proper tool.
Too much tightening may cause the looseness or damage of the screw.
- The strength of tightening is determined by types of screws, strength, the friction of thread face or base face and others.
The table below is for the galvanized or parkerized bolts.
In case that the strength of internal thread is weak, it is not applied.
- Do not use rusty or sand attached "screw."
Otherwise, it may cause insufficient tightening even if you apply the specified tightening torque.
The friction of the screw face becomes higher and the tightening torque is canceled out by the friction, therefore sufficient tightening cannot be applied.
- If "screw" is wet by water or oil, do not tighten it with normal tightening torque.
If the screw is wet, the torque coefficient will get smaller and it may result in too much tightening.
Too much tightening may cause looseness by the screw stretched or result in damage.
- Do not use a bolt experienced too much burden.
- Using the impact wrench requires the skill.
Do exercise as much as possible for steady tightening.

Appended Table

Nominal diameter	General bolt		
	Strength classification 4.8		
	 tib3yb-001		
	N-m	kgf-cm	lb-in
M5	3 - 5	30.59 - 50.99	26.55 - 44.26
M6	7 - 9	71.38 - 91.77	61.96 - 79.66
M8	14 - 19	142.76 - 193.74	123.91 - 168.17
M10	29 - 38	295.71 - 387.49	256.68 - 336.34
M12	52 - 67	530.24 - 683.20	460.25 - 593.02
M14	70 - 94	713.79 - 958.52	619.57 - 831.99
M16	88 - 112	897.34 - 1142.06	778.89 - 991.31
M18	116 - 144	1,182.85 - 1,468.37	1,026.72 - 1,274.54
M20	147 - 183	1,498.96 - 1,866.05	1,301.10 - 1,619.73
M22	295	3,008.12	2,611.05
M24	370	3,772.89	3,274.87
M27	550	5,608.35	4,868.05
M30	740	7,545.78	6,549.74

Appended Table

Nominal diameter	Heat-treated bolt					
	Strength classification 8.8			Strength classification 10.9		
	 tib3yb-002			 tib3yb-003		
	N-m	kgf-cm	lb-in	N-m	kgf-cm	lb-in
M5	5 - 7	50.99 - 71.38	44.26 - 61.96	7 - 10	71.38 - 101.97	61.96 - 88.51
M6	8 - 11	81.58 - 112.17	70.81 - 97.36	14 - 18	142.76 - 183.55	123.91 - 159.32
M8	23 - 29	234.53 - 295.71	203.57 - 256.68	28 - 38	285.52 - 387.49	247.83 - 336.34
M10	45 - 57	458.87 - 581.23	398.30 - 504.51	58 - 76	591.43 - 774.97	513.36 - 672.68
M12	67 - 85	683.20 - 866.75	593.02 - 752.34	104 - 134	1,060.49 - 1,366.40	920.50 - 1186.03
M14	106 - 134	1,080.88 - 1,366.40	938.21 - 1,186.03	140 - 188	1,427.58 - 1,917.04	1,239.14 - 1,663.99
M16	152 - 188	1,549.94 - 1,917.04	1,345.35 - 1,663.99	210 - 260	2,141.37 - 2,651.22	1,858.71 - 2,301.26
M18	200 - 240	2,039.40 - 2,447.28	1,770.20 - 2,124.24	280 - 340	2,855.16 - 3,466.98	2,478.28 - 3,009.34
M20	245 - 295	2,498.27 - 3,008.12	2,168.50 - 2,611.05	370 - 450	3,772.89 - 4,588.65	3,274.87 - 3,982.95
M22	-	-	-	530	5,404.41	4,691.03
M24	-	-	-	670	6,831.99	5,930.17
M27	-	-	-	1,000	10,197.00	8,851.00
M30	-	-	-	1,340	13,663.98	11,860.34

Note:
The same values are applied to "fine screw thread."

Appended Table

Daily Check List

VM60 • VM62 • VM66

- . . . Inspect, adjust, supply, clean (first time)
- . . . Inspect, adjust, supply, clean
- ▲ . . . Replace (first time)
- △ . . . Replace

Maintenance Item	Before Work	After Work	Remarks
Check reel cutter and bed knife	○		
Check roller	○		
Check cover	○		
Check scraper	○		
Clean verti cutter exterior	○		
Check bolts and nuts	○		
Clean verti cutter		○	

Maintenance Schedule

VM60 • VM62 • VM66

- . . . Inspect, adjust, supply, clean (first time)
- . . . Inspect, adjust, supply, clean
- ▲ . . . Replace (first time)
- △ . . . Replace

Maintenance Item	Before Work	Every 50 hrs.	When Required	Remarks
Check cutting depth	○			
Grease		○		
Adjust cutting depth			○	
Adjust rear scraper			○	
Replace vertical blade			△	

List of Adjusted Values

Rear scraper	2 - 3 mm (0.079 - 0.118 in)	Clearance between scraper and roller
--------------	-----------------------------	--------------------------------------

Records

Daily Check Records Page 7-2

Maintenance RecordsPage 7-3

Records

Records

Daily Check Records

VM60 • VM62 • VM66

Use this table freely for your records of the daily check.

Model						Serial Number					
Items											
Check Reel cutter and Bed knife											
Check roller											
Check cover											
Check scraper											
Clean verti cutter exterior											
Check bolts and nuts											
Clean verti cutter unit											

Maintenance Records

VM60 • VM62 • VM66

Use this table freely for your records of the maintenance.

Model					Serial Number					
Items										
Check cutting depth										
Grease										
Adjust cutting depth										
Adjust rear scraper										
Replace vertical blade										

Records

Records

BARONESS[®]
Quality on Demand

 **KYOEISHA CO., LTD.**
Head Office 1-26, Miyuki-cho, Toyokawa-city, Tel :+81-533-84-1390
Aichi-pref, 442-8530 JAPAN Fax:+81-533-84-1220